

# Tutorials for slabs professionals

technical manual

NU PORCELAIN

## TABLE OF CONTENTS

02	<b>01   product</b>
06	<b>02   handling</b>
10	<b>03   storage, loading and transport</b>
20	<b>04   material inspection</b>
21	<b>05   safety recommendations</b>
22	<b>06   production processes</b>
29	<b>07   laying instructions</b>
32	<b>08   drilling holes for wash basin</b>
36	<b>09   assembling 45° edging</b>
37	<b>10   joints</b>
38	<b>11   edge colouring</b>
39	<b>12   support panels</b>
40	<b>13   adhesives and grouting</b>
41	<b>14   laying in contact with heat sources</b>
43	<b>15   cleaning and maintenance during laying</b>
45	<b>16   scratch repairing</b>
46	<b>17   chip filling</b>
47	<b>18   technical characteristics</b>
48	<b>19   safety data sheet</b>

COMPLETELY  
MADE IN ITALY



# 01 | product

## 01.1 surface finishes

### SATIN

The Satin-finish surface is extremely soft to the touch, which makes it an excellent choice for kitchen tops, with an extremely realistic appearance and easy to clean. This particular finish is obtained with an exclusive production process developed by Infinity, characterised by sporadic, microscopic, almost imperceptible irregularities on the surface, visible only in particular light conditions. These specific characteristics can in some cases create an even more realistic effect, without affecting the properties and matchless technical performance of the surface.



Satin

### POLISHED

This perfectly reflective surface is obtained through a progressive mechanical grinding process that uses microabrasive materials with decreasing granularity.

It is mainly recommended for wall coverings and for the creation of various types of furnishing elements.



Polished

### MATTE

A finish particularly appreciated for its transversal nature that makes it suitable for a wide range of applications, guaranteed by balanced aesthetics and excellent performance.

The subtle surface texture enhances the material-like finishes, making it the ideal solution also for floors. The structure of the slab remains soft and makes the surface easy to clean.



Matte

### PATINATED

A finish designed to make even the simplest slab unique, offering a soft and warm feel to the touch.

The aesthetic appearance is enriched by a slight surface movement that provides a well-balanced, homogeneous dynamism without apparent roughness. This aspect is mainly evident when the slab is illuminated by grazing light.



Patinated

# 01 | product

## 01.1 surface finishes

### LEVIGATO PEARL

This exclusive finish gives the surface an extremely smooth feel, similar to natural marble. The surface is completely matt, but its ability to absorb light gives it a subtle reflective effect that makes it ideal for combining with different kinds of material. Imperceptible semi-circular marks give the surface a handcrafted effect that adds originality to each individual slab, setting them apart from serial productions.



Levigato Pearl

### GLAM

The Glam finish effectively marks a further step forward in the technology of the Infinity surfaces. Thanks to the bright, shimmering particles, the light reflects off the surface through the surrounding environment, for a uniquely beautiful result.



Glam

## 01.2 sizes

Infinity is specialised in the production of **large slabs**, up to a maximum size of **1620x3240 mm**. The slabs are composed exclusively of minerals and natural raw materials. **Quartzes, feldspars, clays and kaolins** are **purified**, atomised and pressed, then heated to extremely high temperatures to produce the ceramic body of the Infinity slabs.

With the production system, it is possible to combine **various layers of coloured powders in the body of the slab**, perfecting the desired effect right down to the last detail. All processes for the **production of Infinity** are **carried out in Italy**.

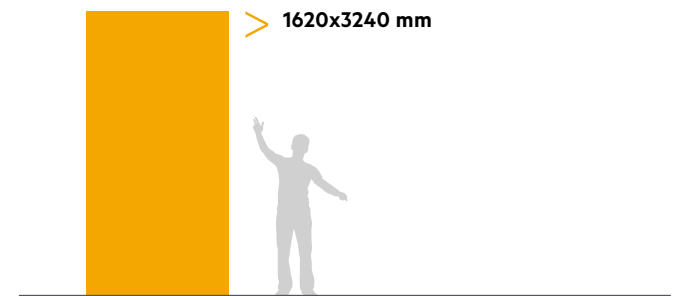

## 01.3 shade

The characteristics of the production process of Infinity include the management to obtain homogeneous production batches.

In fact, although the same product taken from two different production batches from different times maintains aligned graphics and colours, there may still be slight differences in tone due to the natural origin of the raw material use.

## 01.5 benefit

High resistance to hydrolysis

High resistance to temperature variation

High resistance to frost

High resistance to abrasion and wear and tear

High resistance to compression

Resistance to the contact with hot objects

Resistance to the exposure to N rays  
(possibility of application outdoors)

Resistance to chemical products (see chart pag.39)

Limited thermal expansion

Fireproof

Possibility of custom sized

Possibility to personalise products and sizes based on the application

## 01.4 nominal thicknesses



## 01.6 applications

Thickness	6 mm	12 mm	20 mm
Interior furnishings	■	■	■
Outdoor furnishings	■	■	■
Indoor flooring, light-duty	■	■	
Indoor flooring, heavy-duty		■	
Indoor wall coverings	■		
Outdoor wall coverings	■		
Raised flooring	■	■	
Ventilated façade	■	■	■
Countertops	■	■	■

### Points to note carefully about the Levigato Pearl surface

**i** Because of the distinctive, extremely smooth tactile sensation of the Infinity surface afforded by the exclusive Levigato Pearl finish, there are a number of particular points to consider carefully, to ensure correct maintenance of the surface.

The Levigato Pearl finish is suitable for creating furnishing elements (kitchen tops, tables, etc.), and for tiling walls only: it cannot be installed on floors, even in residential settings. When installed as a kitchen top or as a finish for a table, "coloured stains" (such as those caused by wine or coffee) should be removed by cleaning the surface within two hours, using warm water and a neutral detergent, so as to ensure no traces remain. Contact must be avoided between the Levigato Pearl surfaces and alkaline degreasers (for example, degreasers containing hydroxide for cleaning ovens or sink pipes). The use of abrasive or metal sponges should also be avoided, and a soft sponge or cloth should always be used. For any particular problems, we always advise contacting an Infinity technician before applying any kind of product to the surface.

For more information: [info@infinitysurfaces.it](mailto:info@infinitysurfaces.it)

# 02 | handling

The loading and unloading operations and transport of Infinity slabs require the use of a forklift, an overhead crane or other suitable lifting equipment. It is essential to follow the instructions for use provided by the manufacturer, complying with the maximum load values and ensuring that all the elements used have undergone proper maintenance.

*It is absolutely essential* for handling that **the slabs are kept perfectly balanced, considering their barycentre in order to prevent them from bending and breaking.**

Infinity slabs can be handled manually or with the aid of specific instruments. Examples of such instruments include:

- Suction cups;
- Forklift;
- Straps;
- Clamps;
- Overhead crane with a winch;
- Hoist.

## 02.1 manual handling

Infinity slabs can be handled manually by specialised workers wearing protective gloves and taking all the safety precautions necessary.

When the slabs are applied to walls it is important that they are moved vertically (*fig. 1*), in order to reduce any bending of the slab itself.

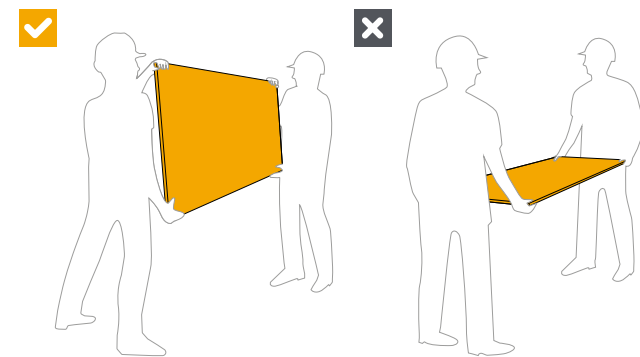

fig. 1

When handling slabs to be laid as kitchen worktops, in addition to keeping them in a vertical position, we highly recommend that they are glided into place on the support surface of the countertop (*fig. 2*).

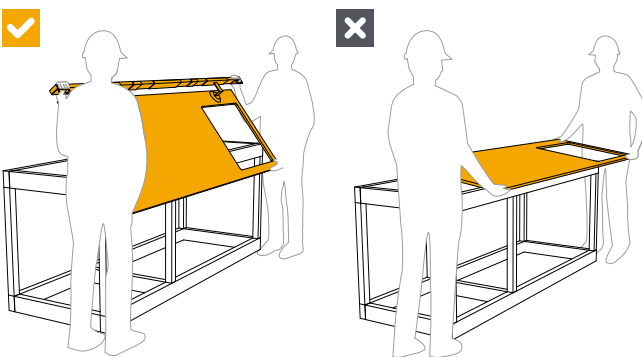
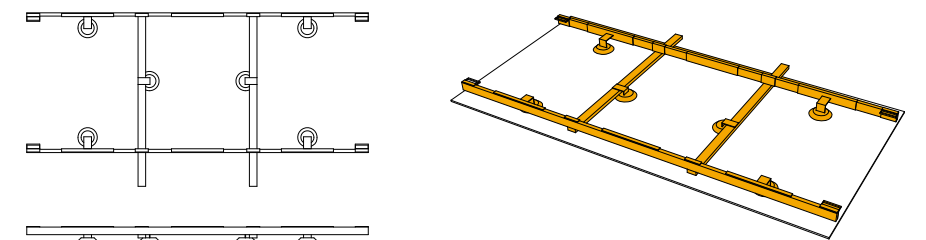

fig. 2

## 02.2 handling with suction cups

To ensure safety for the workers handling the slabs and to avoid breakages, we strongly recommend using a handling frame with safety suction cups.

These can be easily moved along the frame. They are highly versatile and can be adapted to any size.



By applying a system of bars fitted with suction cups, the slab can be made more rigid, allowing it to be handled with total peace of mind. If the suction cups are evenly distributed over the material, it will bend less. Before applying the suction cups, it is wise to thoroughly clean

the surface of the slab.

Depending on the size of the slab to be handled, 2 to 4 people will be needed for this operation.

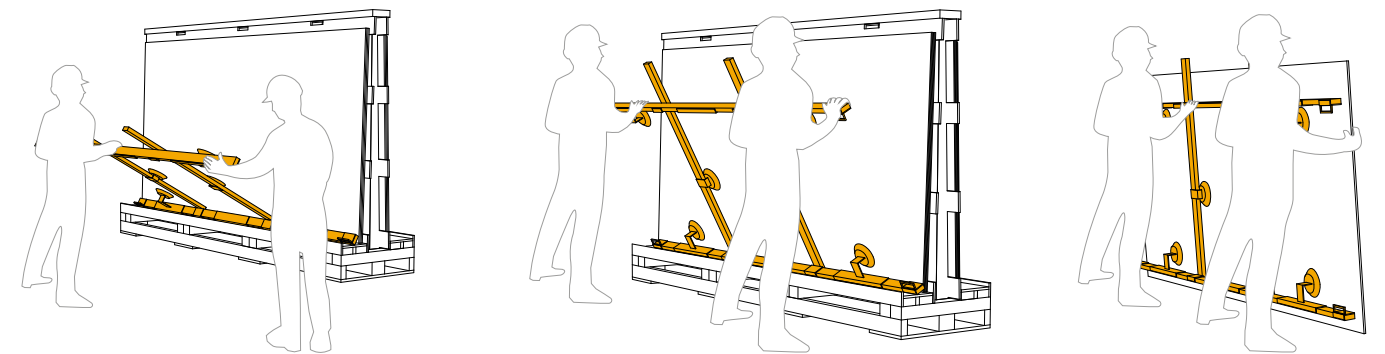

The use of a frame becomes essential when moving slabs in which holes have been drilled.

For all cutting and drilling operations we advise the use of a stable, flat worktop.

If no suction cups are available, an aluminium or wood bracket can be used.

This should be fixed to the slab with several clamps in order to prevent the slab from excessive bending during handling.

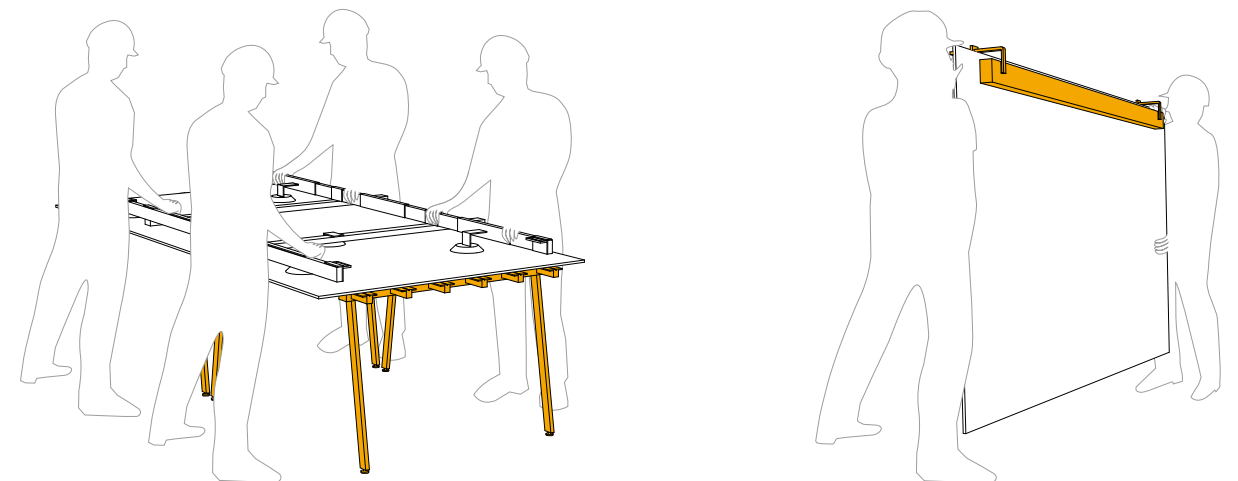

## 02 | handling

### 02.3 handling with a forklift

To handle a-frame containing Infinity slabs, forklift trucks with a minimum capacity of 5 metric tons or special vehicles are necessary.

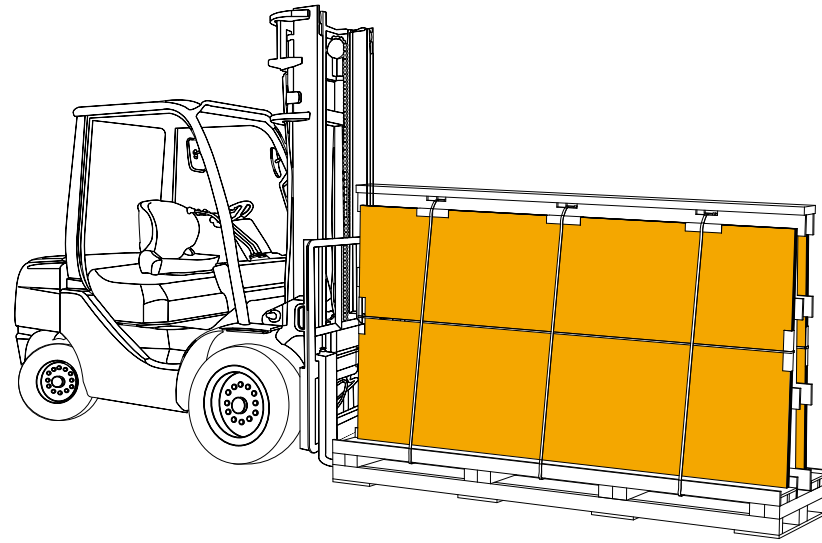

### 02.4 handling with straps

To move and handle several slabs at the same time, straps or harnesses can be used. The straps must not directly touch the slab in order not to ruin/scratch the surface itself.

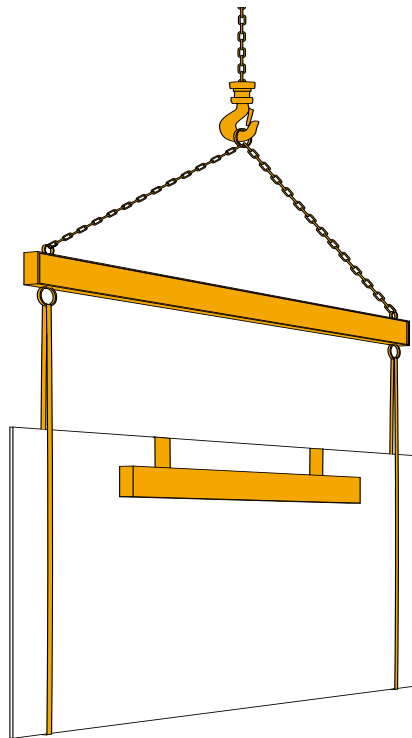

### 02.5 handling with clamps

It is possible to move the slabs individually using lifting clamps, which can lift slabs with thicknesses ranging from 6 mm upwards.

The use of clamps will allow the slab to bend less during movement, thus minimising any risk of breakage. **It is not possible to lift more than 2 slabs at a time with this type of clamp.**

**The metallic surfaces of the clamps must not come into contact with the surface of the slab** in order to avoid marks or other problems. It is thus essential to use spacers - in wood or adhesive rubber tape - which keeps the parts separate.

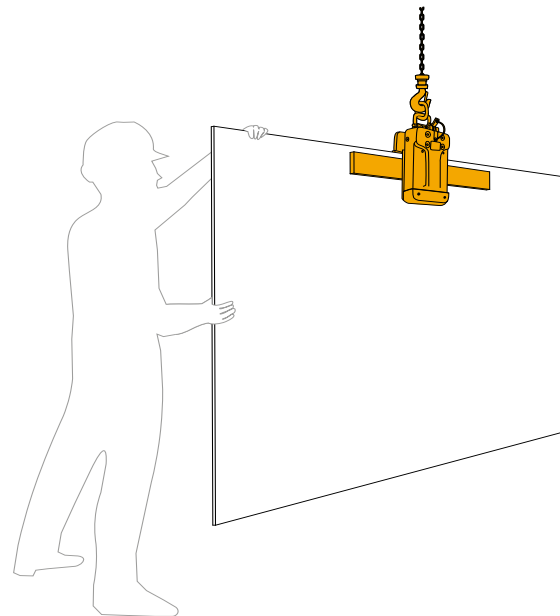

### 02.6 handling with overhead crane and winch

With the use of an overhead crane and a winch it is possible to handle slabs individually or in sets of several slabs.

Individual slabs should be moved in the following way:

- Separate the individual slabs from the rest, either manually or (in the case of excessively heavy slabs), using a hoist (this operation must be carried out on both sides);
- Keep the slab separate from the rest by means of a joist;
- Position the straps of the overhead crane around the entire slab;
- Lift;
- Move to the storage area, ensuring that any oscillation does not cause any hazards for the machinists;
- Correctly position the slab on a trestle or other rail (this operation will require the machinist to «manually» guide the slab safely into the desired place).

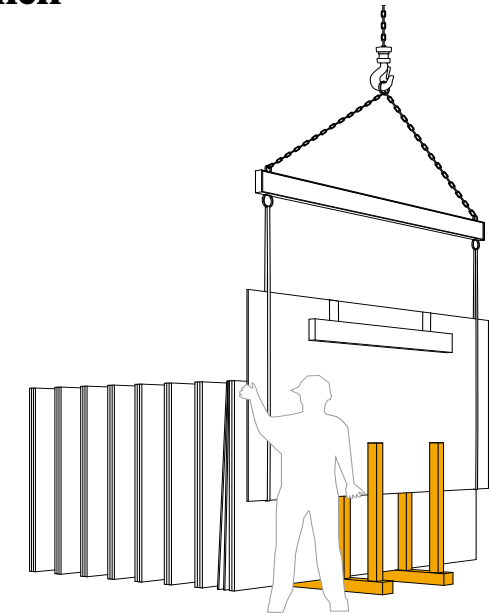

### 02.7 handling with hoist

Hoists are used to lift and move heavy loads. They are installed on an overhead crane to allow medium-heavy weights to be lifted, simply by using a control panel.

Several different types of hoist are available depending on the specific handling needs.

#### ■ Rope hoist

In most cases, rope hoists are electrically driven. Its construction shape makes it the preferred type of machine to be installed on an overhead crane, as it is generally used for use with larger and heavier objects compared to those that can be handled by a chain hoist (and is therefore suited to the lifting of large loads).

#### ■ Chain hoist

This is the most common type of hoist for cranes and is generally required to have a capacity of between 125 and 2000 kg. Chain hoists are also available on the market with a capacity of up to 5000 kg.

#### ■ Wheeled hoist

Where the installation of an overhead crane is too complicated, hoists on wheels can be used. They are easy to move across hard, level floors and are easy to manoeuvre in any direction needed.

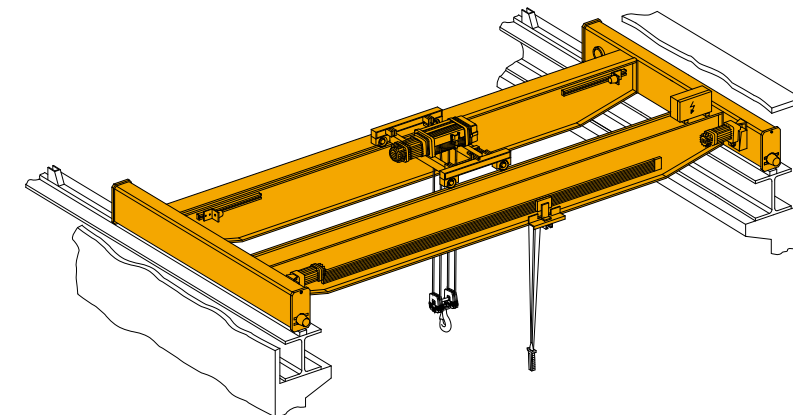

# 03 | storage, loading and transport

Infinity slabs must be loaded and transported in conditions of total safety in order to safeguard their appearance, original characteristics and to avoid accidental breakage.

## 03.1 loading and transport on trucks

By taking suitable precautions, a truck can transport the slabs **on iron or wooden a-frame**.

During transportation, it is essential to support and protect the Infinity slabs against possible shocks and sudden jerks. For this reason, **we recommend fixing the a-frame in place using mechanical aids such as straps in polyester** (or a similar material).

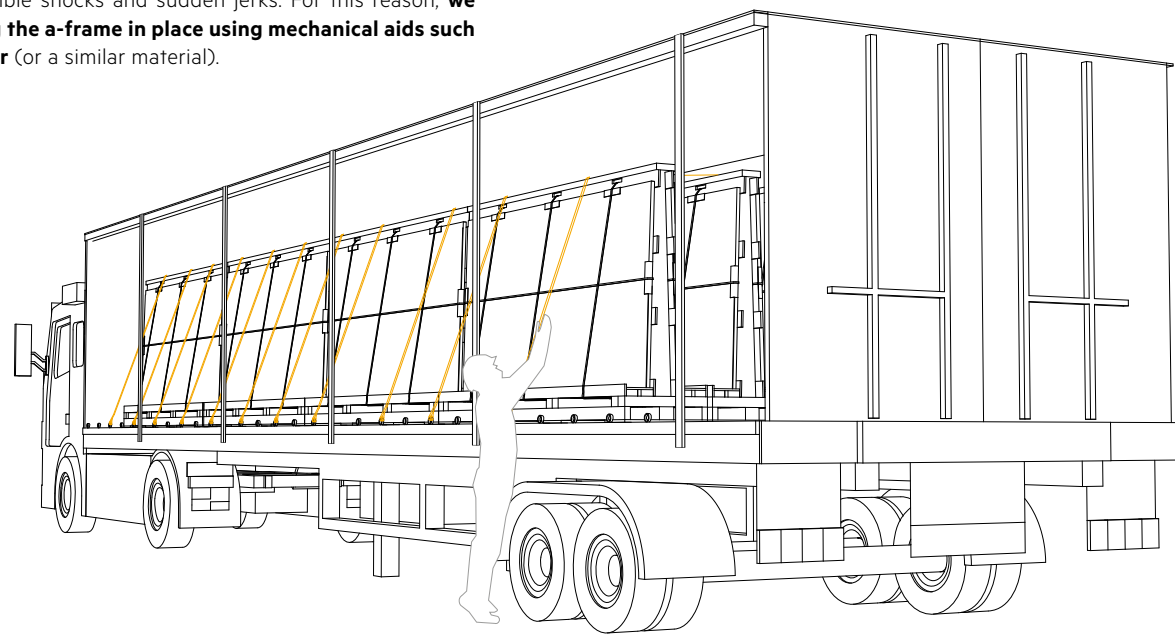

Prior to loading and shipping, **specific precautions** must be taken to prepare for the packaging.

The person-in-charge must pay the utmost attention to ensure that the products are properly balanced to guarantee the safety of any people in the area, keeping the load at a reduced height during handling, and raising it only when it reaches the truck.

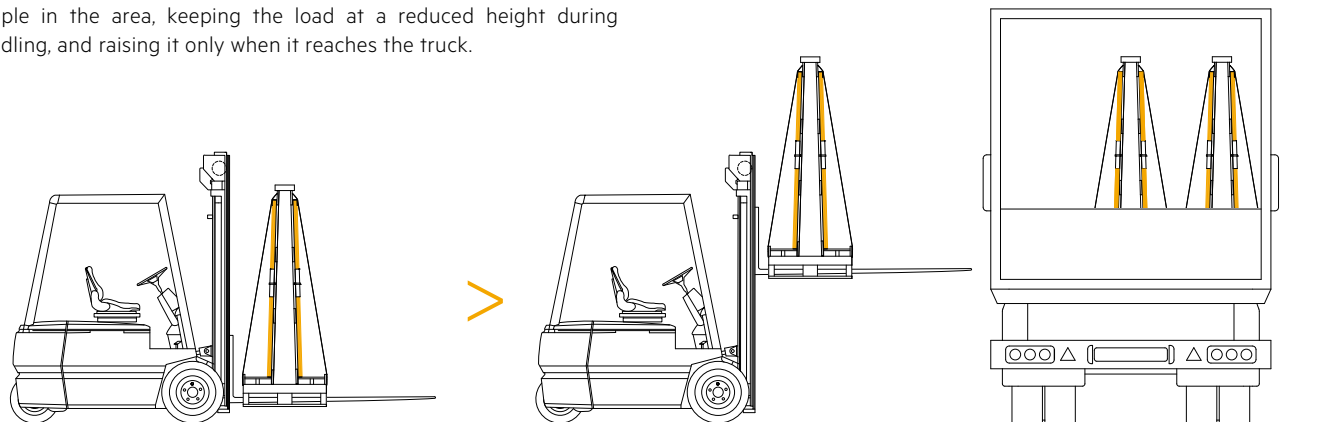

## 03.1.2 iron a-frame (recommended packaging)

Iron a-frame are ideal for correctly positioning the Infinity slabs.

With a weight of around 25% less compared to wooden a-frame, they are extremely sturdy and have the advantage that the load can be arranged on both sides of the forklift trucks. Iron a-frame also allow the load to be handled easily with an overhead crane and winch, by means of the specific built-in fixtures for hooks (fig. 1).

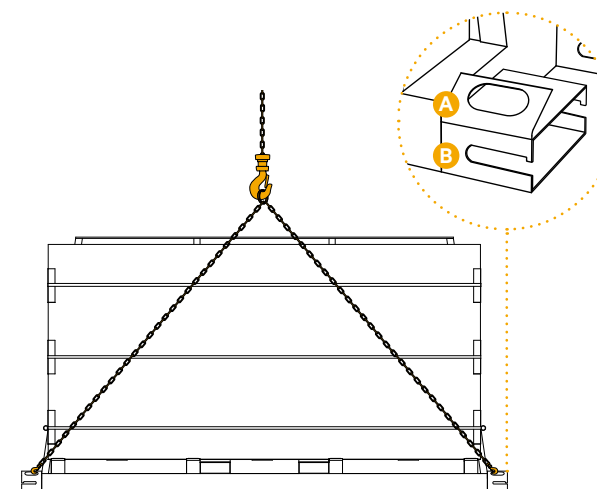
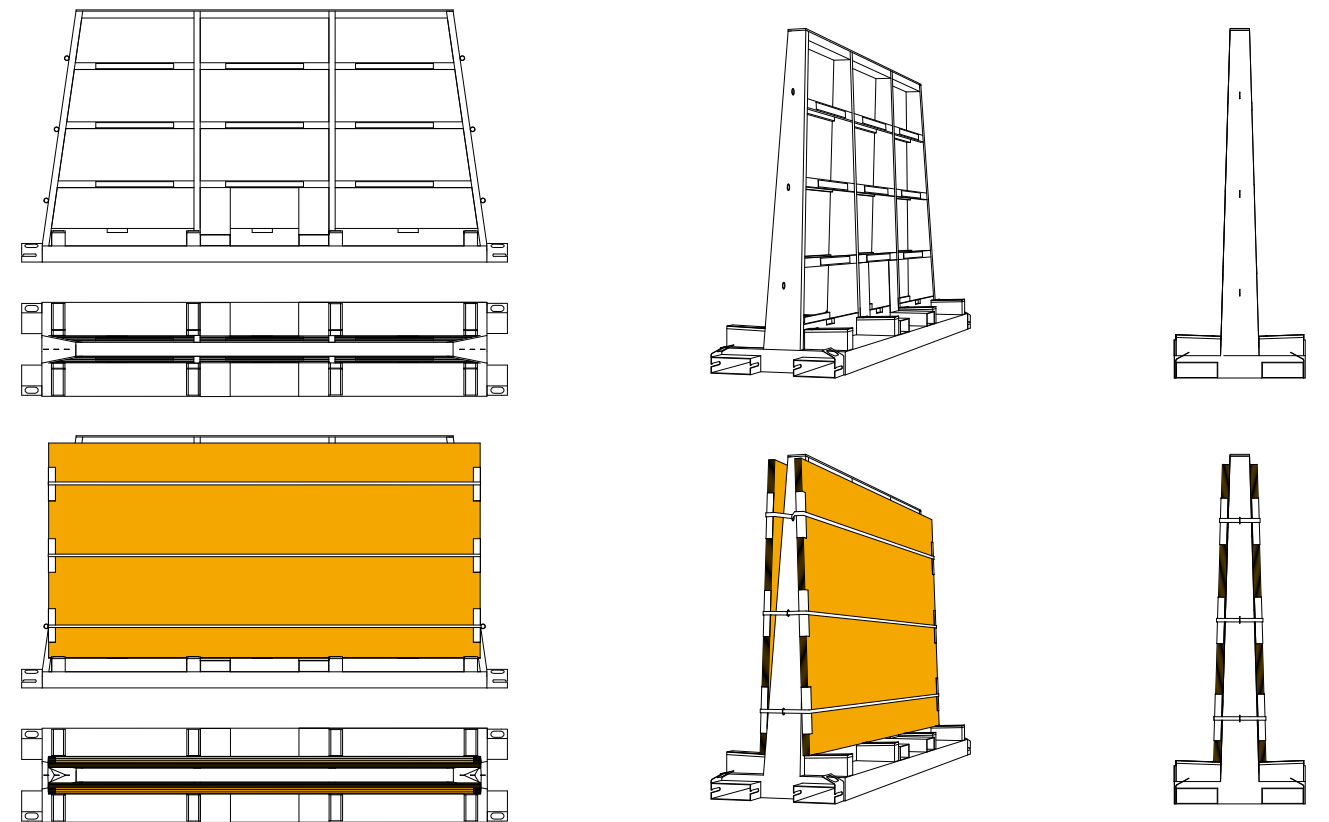

fig. 1 A. Chain hook B. Belt slot

Packaging	Iron a-frame		
Packaging dimensions (cm)	330x73,5x190		
Weight of packaging, empty (kg)	160		
Size of slab (cm)	162x324x0,6	162x324x1,2	162x324x2
Weight of single slab (kg)	85	150	260
Pieces per single a-frame (no.)	42	22	12
Slabs transported (m <sup>2</sup> )	215,04	112,64	61,44
Weight of a-frame + slabs (kg)	3390	3460	3280

# 03 | storage, loading and transport

## 03.1.3 wooden A-frame

Below we have indicated the precautions necessary to position the Infinity slabs correctly on the a-frame.

- In the case of slabs with different sizes, we strongly recommend arranging the slabs in order of size, starting with the smallest (fig. 1);
- In the case of slabs in which holes have been cut, we recommend placing the entire surface of the slab on the a-frame and avoiding any overhanging parts (fig. 2);
- Cardboard layer pads/wax rails positioned between each slab, to prevent any strain developing between the slabs and prevent them from knocking against each other (fig. 3);
- Protection for the outer edges (fig. 4);
- The "block" of slabs must be tied together using steel straps to prevent the slabs from moving during transport (fig. 5);
- Shrink-wrapping (fig. 6 - fig. 7).

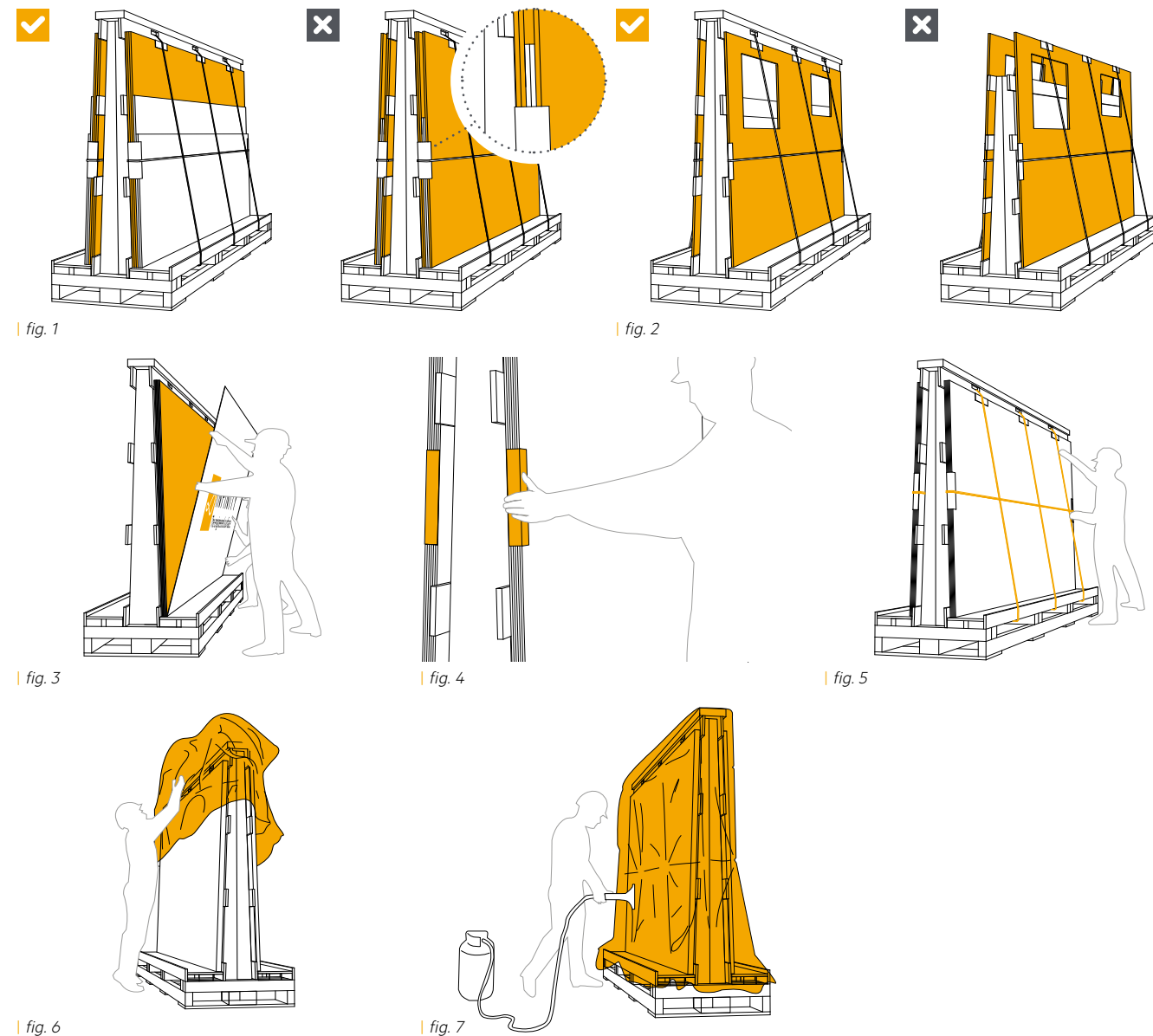

Infinity can manage the handling and transport of its slabs with the aid of **a-frame**.

Thickness	6 mm	12 mm	20 mm
Packaging dimensions (cm)	330x75x200	330x75x200	330x75x200
Weight of packaging, empty (kg)	206	206	206
Size of slab (cm)	162x324x0,6	162x324x1,2	162x324x2
Weight of single slab (kg)	85	150	250
Pieces per single a-frame (no.)	42	22	12
Slabs transported (m <sup>2</sup> )	215,04	112,64	61,44
Weight of a-frame + slabs (kg)	3776	3506	3206

## 03.1.4 wooden trestle: examples of arrangement on truck (depending on the vehicle length)

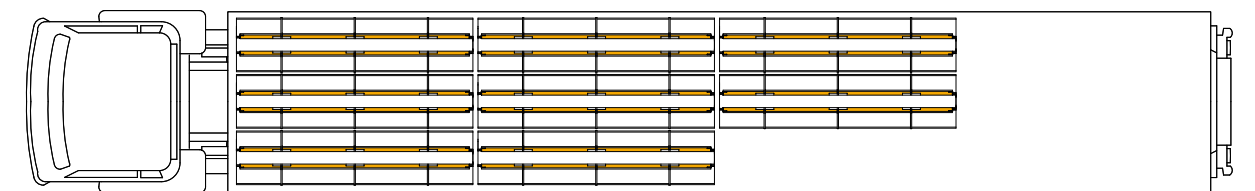

Truck - Loading arrangement	6 mm		12 mm		20 mm	
	M <sup>2</sup>	Metric tons	M <sup>2</sup>	Metric tons	M <sup>2</sup>	Metric tons
8 A-frame 1620x3240	1720,32	30,2	701,12	28,1	491,52	25,6

# 03 | storage, loading and transport

## 03.2 transport by container

The Infinity slabs can be shipped in 20' and 40' containers.

■ **20' Container**  
 (5.90 x 2.32 x 2.35(h) m) - maximum loadable weight 27.9 metric tons

■ **40' Container**  
 (11.90 x 2.32 x 2.35(h) m) - maximum loadable weight 26.8 metric tons

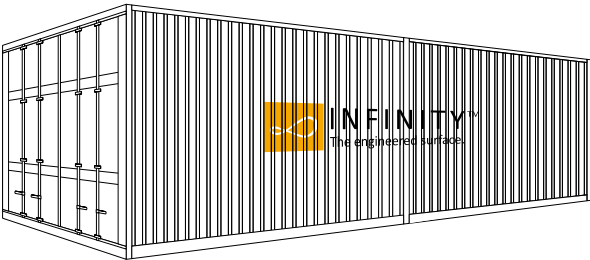
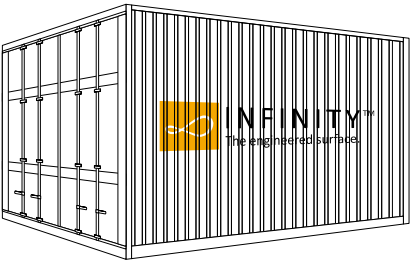

Below are the possible combinations of trestle containers.

### 03.2.1 20' container: examples of loading arrangement

20' container - Loading arrangement	6 mm		12 mm		20 mm	
	M <sup>2</sup>	Metric tons	M <sup>2</sup>	Metric tons	M <sup>2</sup>	Metric tons
3 A-frame 1620x3240	645,12	11,3	337,92	10,6	184,32	9,6

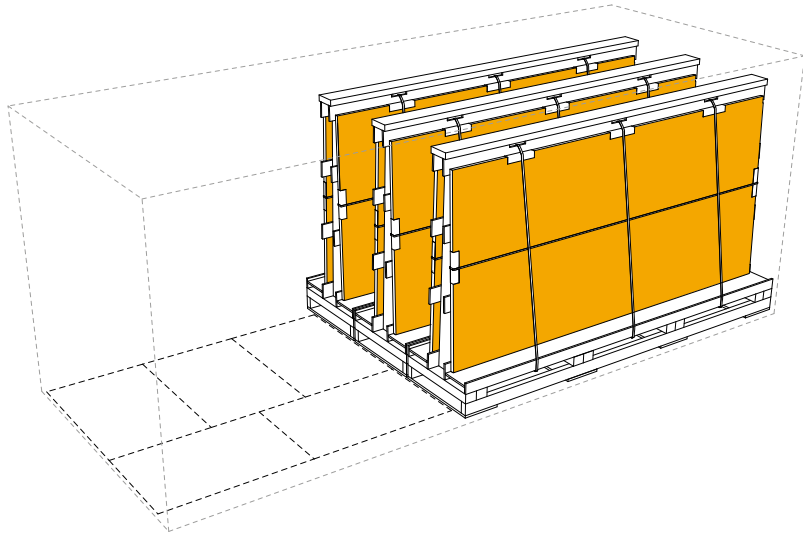

### 03.2.2 40' container: examples of loading arrangement

40' container - Loading arrangement	6 mm		12 mm		20 mm	
	M <sup>2</sup>	Metric tons	M <sup>2</sup>	Metric tons	M <sup>2</sup>	Metric tons
7 A-frame 1620x3240	1505,28	26,4	788,48	24,6	430,1	22,4

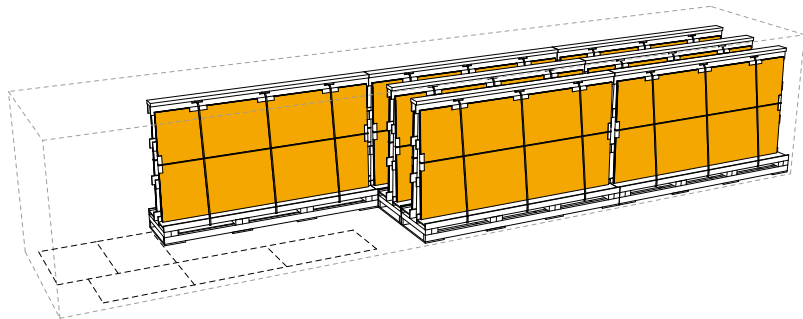

### 03.2.3 transport by container: airbag

To guarantee the maximum safety during shipment, it is advisable to insert **protective blow-up cushioning (airbags)** in polypropylene into the containers.

The airbags are placed in any empty spaces in the loading area, and are subsequently blown up with compressed air until all such areas are completely filled, consolidating the stability of the surrounding materials.

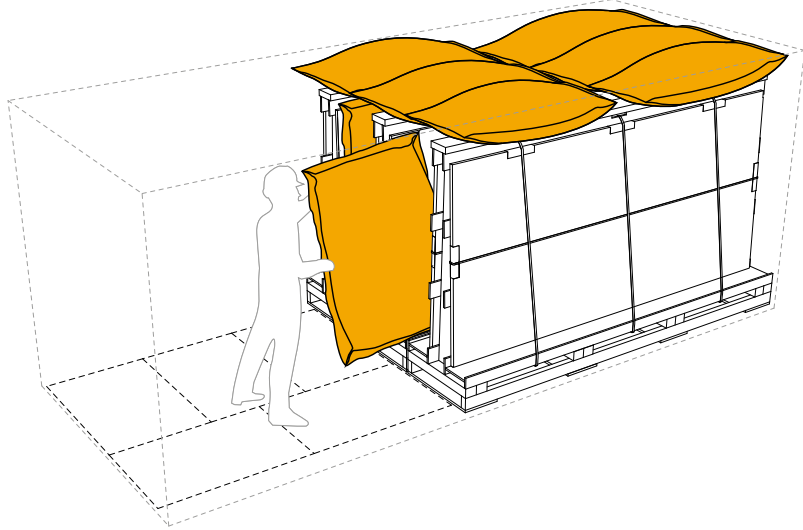

# 03 | storage, loading and transport

## 03.2.4 transport by container: bundle

In order to make the transport of the Infinity slabs on open side or open top containers, **special packaging** can be used (by special request of the client) referred to as **"Bundles"**.

The bundles are characterised by a structure in soft wood, consisting of a base fitted with 2 feet and 4 uprights (fig. 1). If bundles are used, we recommend shrink-wrapping them once packed to avoid any unsightly stains forming on the top surface of the slab (fig. 2).

It is also wise to place a wooden board over the feet of the structure on which the load is to be placed to protect the material when the bundled is lifted (fig. 3). So as not to damage the slabs during handling with chains, it is finally preferable to use 2 wooden boards to protect the surface (fig. 4).

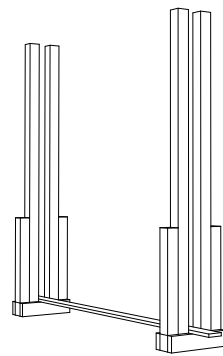

fig. 1

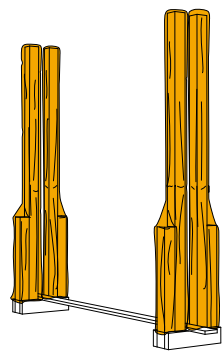
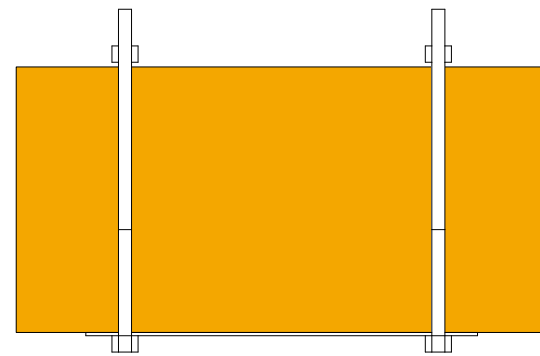
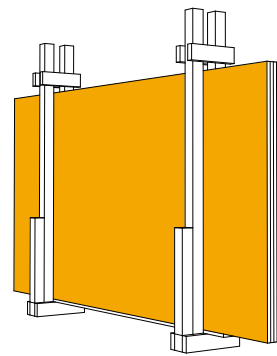

fig. 2

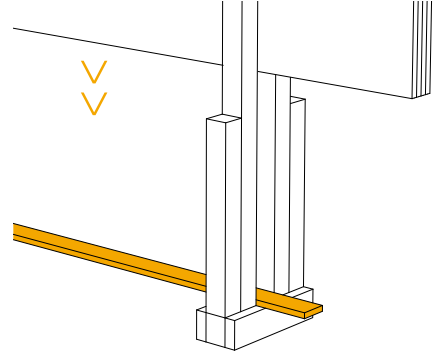

fig. 3

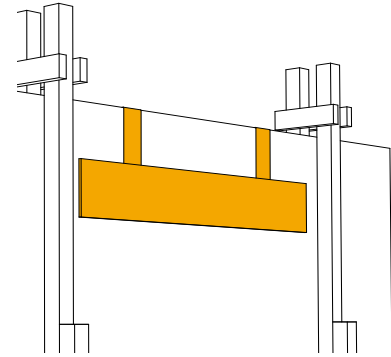

fig. 4

Thickness	6 mm	12 mm	20 mm
Size of slab (cm)	160x320x0,6	162x324x1,2	162x324x2
Weight of single slab (kg)	85	150	250
Pieces per single bundle (no.)	27	18	11
Slabs transported (m <sup>2</sup> )	138,24	92,16	56,32
Weight of bundle (kg)	2395	2800	2850

## 03.2.5 20' container: examples of loading arrangement

### 20' container - Loading arrangement

#### 8 Bundle 1620x3240

6 mm		12 mm		20 mm	
M <sup>2</sup>	Metric tons	M <sup>2</sup>	Metric tons	M <sup>2</sup>	Metric tons
1105,92	19,2	737,28	22,4	450,56	22,8

The bundles can be loaded and unloaded by means of an overhead crane fitted with a machine-load-container system; alternatively, forklift trucks can be used that are fitted with straps to allow the bundles to be handled.

**To ensure the adequate safety of the load during shipment, the lower axes of the bundles are appropriately anchored to the container.**

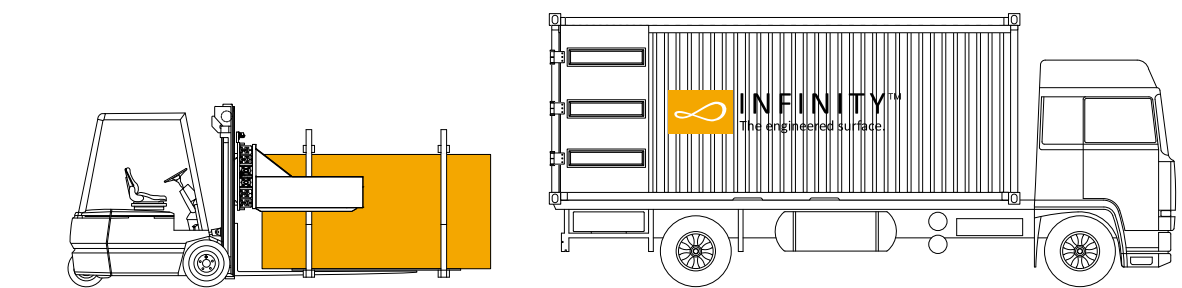
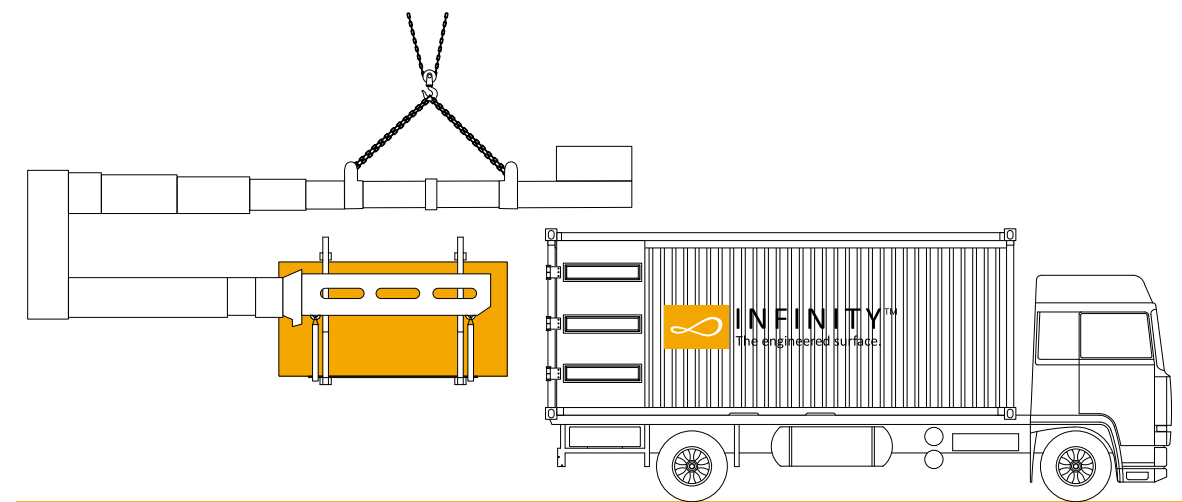

Below are the general rules to guarantee the safe transportation of the Infinity slabs.

- Inspect the container both inside and outside prior to loading to check for the presence of any damage;
- Load the container up to the maximum weight allowed (this is usually indicated on the container itself, and in certain cases subject to stricter rules compared to those in place in the Country of importation);
- Check the correct distribution of the load (bundles) and that they have been properly fixed inside the contain.

# 03 | storage, loading and transport

## 03.3 crate (optional packaging)

Optionally, the Infinity slabs can be arranged on a crate; below are the precautions to follow for safer packaging.

- Sheet of polystyrene placed at the bottom of the crate (fig. 1);
- Protective layer of 4 waxed rails positioned between each slab, to prevent any strain developing between the slabs and prevent them from knocking against each other (fig. 2);
- Lid bears drawing showing all the product-related information (fig. 3);
- Shrink-wrapping (fig. 4).

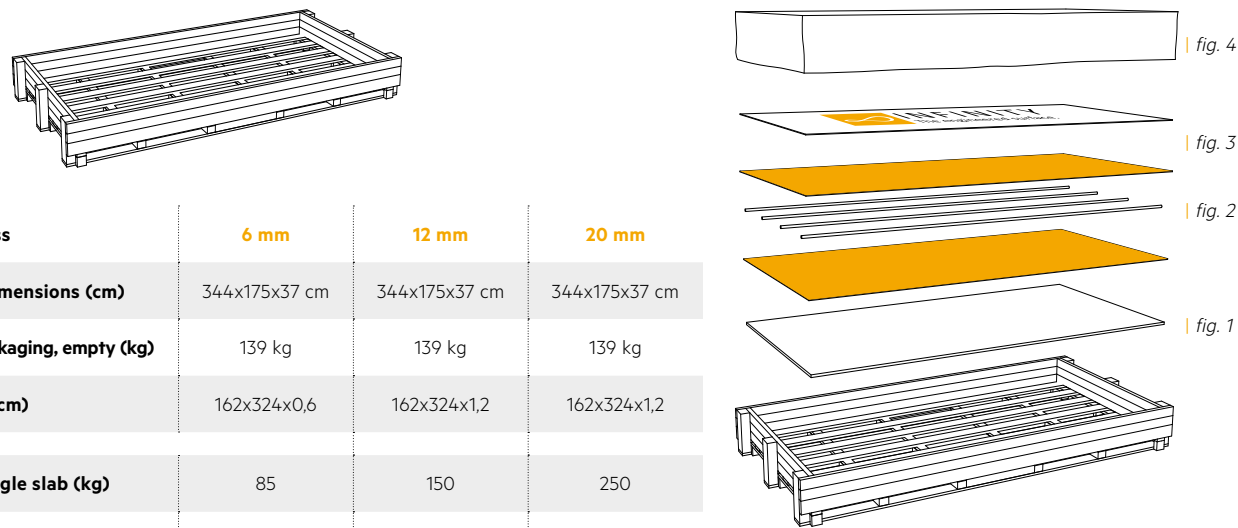

Slab thickness	6 mm	12 mm	20 mm
Packaging dimensions (cm)	344x175x37 cm	344x175x37 cm	344x175x37 cm
Weight of packaging, empty (kg)	139 kg	139 kg	139 kg
Size of slab (cm)	162x324x0,6	162x324x1,2	162x324x1,2
Weight of single slab (kg)	85	150	250
Pieces per single crate (no.)	14	8	4
Slabs transported (m <sup>2</sup> )	71,68	40,96	20,48
Weight of crate + slabs (kg)	1329	1339	1139

### 03.3.1 crate (optional packaging): examples of loading arrangement on truck (depending on the vehicle length)

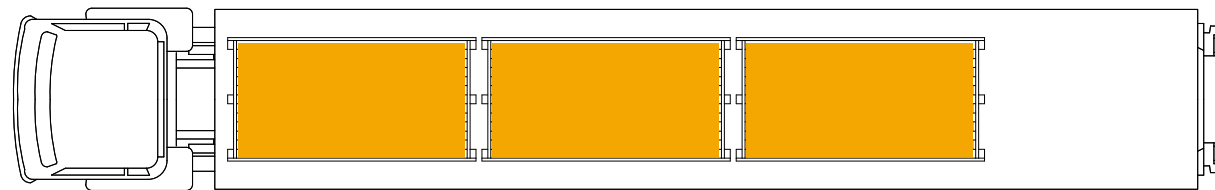

Truck - Loading arrangement	6 mm		12 mm		20 mm	
	M <sup>2</sup>	Metric tons	M <sup>2</sup>	Metric tons	M <sup>2</sup>	Metric tons
18 Crates 1620x3240	1290,24	20,0	737,28	20,1	378	20

### 03.3.2 20' container: examples of loading arrangement

20' container - Loading arrangement	6 mm		12 mm		20 mm	
	M <sup>2</sup>	Metric tons	M <sup>2</sup>	Metric tons	M <sup>2</sup>	Metric tons
6 Crates 1620x3240	430,08	6,6	245,76	6,7	126	6,7

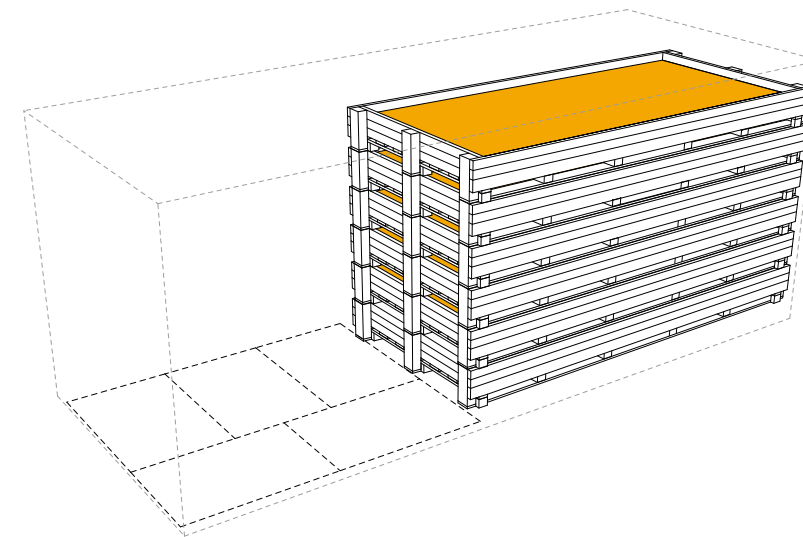

### 03.3.3 40' container: examples of loading arrangement

40' container - Loading arrangement	6 mm		12 mm		20 mm	
	M <sup>2</sup>	Metric tons	M <sup>2</sup>	Metric tons	M <sup>2</sup>	Metric tons
18 Crates 1620x3240	1290,24	19,9	737,28	20,1	378	20

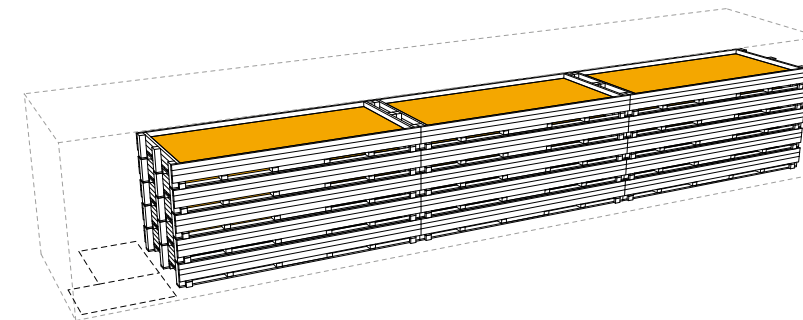

## 04 | material inspection

The Infinity slabs are composed of natural raw materials and are accurately produced and selected in strict compliance with the required high standards of quality. The person responsible for working the material must visually inspect the slabs prior to use, after accurately cleaning the surface. Any dissimilarity found must be reported before any work is performed on the material.

The following aspects need to be checked:

### ■ Dimensions

When the Infinity slabs destined to countertops and furnitures come out of production, they are **non-rectified**; it is thus possible to define the most suitable cutting process, depending on the final product.

The rough size of non-rectified slabs is 1620x3240 mm, which can be reduced as desired.

### ■ Flatness

Flatness (or planarity) refers to the quality of having a perfectly level and stable surface without raised areas or indentations.

The flatness of Infinity slabs meets the highest quality standards and falls with the tolerances given below.

	Width	Length
Tolerance	2 mm	4 mm



### ■ Choice

Infinity classifies its slabs into three distinct categories with regard to the surface quality.

The department responsible for this procedure is managed by specialised technicians and subdivides the material into 3 types.

**Q 1** - materials of first choice.

**Q C** - materials of second choice.

**Q S** - materials with defects.

All information contained in this manual refers to the materials of first choice.

### ■ Labelling

Each Infinity slab bears a label containing information such as **identification code** of the **product, size, tone, quality** and **finish**.

**The label allows the traceability of the surface and all the production phases it has gone through in the production plant, with the slab (production batch) number.**

**Infinity will not accept reports or complaints once the product has been cut and laid, for visible defects verifiable before the processings of the slabs.**

### ■ Thickness

Nominal thickness	6 mm	12 mm	20 mm
-------------------	------	-------	-------

### ■ Shade

Infinity slabs are produced from natural raw materials and created by means of an industrial process; they may consequently vary slightly in appearance.

**For this reason, Infinity carries out strict controls to mark any tones from the same production batch that are different.**

**It is not possible to repeat any tone;** if the finish is still in production, it is possible to search for and provide any existing material in the warehouse with the most similar tone to any previously purchased slabs.

Colour and tone are marked on the special label of the surface with the respective code.

### ■ Surface

All surfaces of Infinity slabs can be made in 6 different types of finish depending on the design requirements:

**Satin;**

**Polished;**

**Matt;**

**Patinata;**

**Glam;**

**Levigato Pearl.**

## 05 | safety recommendations

### 05.1 before starting: safety recommendations

Before beginning any work, carefully review the safety data sheets available at <https://www.infinitysurfaces.it/pdf/Infinity-SafetyDataSheet.pdf>

Do not proceed until you have fully read, understood, and implemented all necessary safety precautions in accordance with relevant legislation and the specific conditions of your job.

**Safety measures must be adapted to the specific conditions of each job.**

**These recommendations are not universal and do not replace legal health and safety obligations under applicable local regulations.**

During processing of slabs, breathable crystalline silica may be released into the air.

To minimize uncontrolled dust emissions:

- **Always use cutting tools equipped with water-based dust extraction systems.**
- **Wear appropriate respiratory protection equipment based on applicable regulations and workplace conditions.**
- **Avoid generating airborne dust, especially in areas without proper air filtration and ventilation systems.**  
The suitability of such systems must be assessed for each specific environment.
- **Restrict access to the work area to ensure the safety of those not involved in the process.**
- **Ensure proper cleaning of work garments:**  
use a vacuum system specifically designed for fine dust or have garments professionally laundered.

# 06 | production processes

## 06.1 tension relief cut

If a customer decides to purchase a non-rectified slab, before performing any work on a non-rectified slab, Infinity recommends removing 20-30 mm of material around the edges. This operation is essential to reduce the natural strain of the slab after the moulding process, which might favour breakages due to the mechanical smoothing processes.

The removing processes is recommended on all colours and any surface in the thickness of 12 mm and 20 mm, and even in the minimum thickness of 6 mm.

Here is the correct procedure to follow:

- Both sides along their entire length;
- Both sides along their entire width.

**It is important to reduce the cutting speed by 50% compared to the usual speed for about 15-20 cm, both at the beginning and at the end.**

**Considering the possible variables during cutting and drilling operations, accidental breakages cannot be excluded a priori, and these cannot be attributed to or managed by Infinity under any circumstance.**

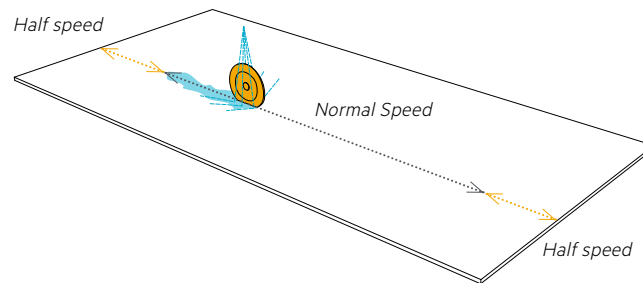
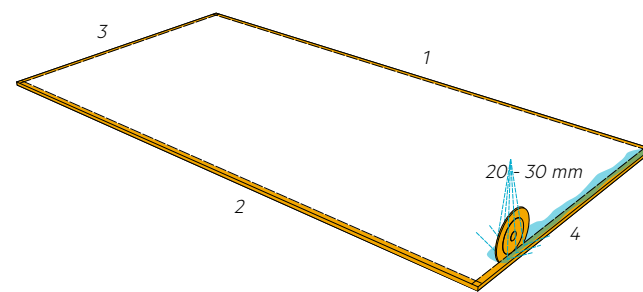

## 06.2 straight cuts

It is possible to cut the Infinity slabs in a straight line using both diamond tools and water-jet cutting instruments. Whatever apparatus is used, we recommend cutting the material in such a way to leave a minimum size of 40 mm at the end to obtain a perfectly flat cut-off.

**Infinity recommends using diamond cutting tools on-site only for materials with a thickness of 6 mm,** while for greater thicknesses it is preferable to use tools such as water-cooled diamond blades or water-jet cutting instruments (fig. 1), which makes it possible to prevent breakages and facilitate the cutting operations.

If straight cuts have to be made on the material during installation, it is also possible to use special aluminium cutting guides fitted with a diamond scoring blade, fixing the guides to the slab by means of suction cups (fig. 2). To ensure that the material is cut correctly, the material must be scored starting at a distance of 10-20 mm from the end of the slab, working from the centre towards the edges. Then proceed to make an incision from one edge to the other, taking great care to maintain a constant pressure along the entire cutting line.

For slabs with a thickness of 12 or 20 mm, Infinity recommends the use of water-jet cutting instruments. This guarantees additional advantages, such as a high degree of precision and the absence of any thermal or mechanical alterations to the material (fig. 3). Alternatively, a water-blade saw may also be used.

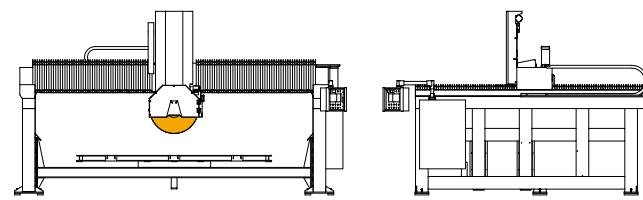

fig. 1

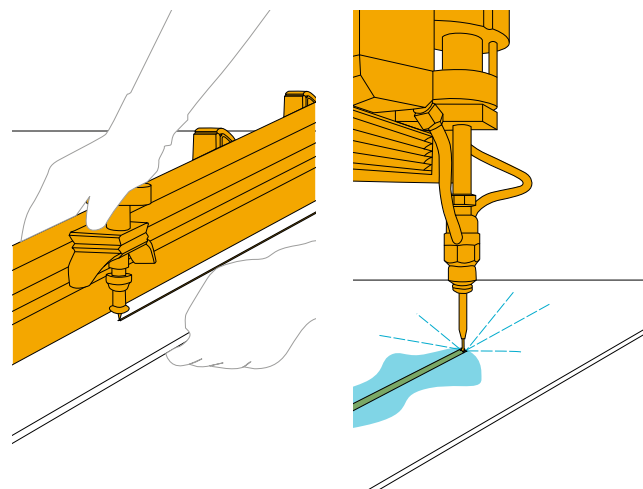

fig. 2

fig. 3

## 06.3 basic instructions and tips for using a bridge saw

Infinity recommends taking the following precautions when using a bridge saw:

- The work bench must be solidly built, perfectly flat and free of residues and debris of any size;
- The work bench must be in good condition, if necessary fitted with an underlay in high-density technical rubber, such as Ecorubber or similar;
- There must be a constant, strong jet of water in front and at the side of the disc, as close as possible to the cutting area;
- We recommend reducing the cutting speed to a maximum of 20 cm/mn for the first and final 20 cm of cutting;
- When cutting small elements, such as strips, risers, front trims etc.), we recommend clamping the material into place at the side to prevent the disc from backlashing when it starts or finishes cutting;
- The disc should be released fully from the material cut;
- In the case of multiple cuts on the slab in different directions (for example L-shaped cuts), and when changing direction, always drill a small hole first to avoid sharp right-angle cuts;
- Sharpen the disc at regular intervals.
- The disc diameters shown in the table are indicative and not binding. It is possible to use discs with diameters, adjusting the number of revolutions per minute so as to always have an indicative tangential velocity of 35-40 m/s.

Nominal thickness	Disc diameter	Rpm Range	Cutting speed m/mn for straight cuts*	Cutting speed m/mn for 45° cuts**
6 mm	300	2300 - 2500	UP TO 3 (based on the blade you selected)	1.4 - 1.7
	350	2000 - 2200		
	400	1700 - 1900		
	450	1400 - 1800		
12 mm	300	2300 - 2500	UP TO 3 (based on the blade you selected)	0.60 - 0.70
	350	2000 - 2200		
	400	1700 - 1900		
20 mm	300	2300 - 2500	UP TO 2 (based on the blade you selected)	0.40 - 0.60
	350	2000 - 2200		
	400	1700 - 1900		
	450	1400 - 1800		

\* Reduce the cutting speed to a maximum of 20 cm/mn for the first and final 20 cm of cutting;

\*\* Reduce the cutting speed in the first 15 cm of the upper and lower part of the slab.

**i** Please remember that these parameters are indicative only and will depend on the type of disc, the machinery used, and the manufacturer's instructions. We recommend using a tool with speed adjustment in order to adjust the Rpm, to be able to monitor the cutting process in detail and not rely solely on personal experience.

# 06 | production processes

## 06.4 basic instructions and tips for using water-jet cutting instruments

Infinity recommends taking the following precautions when using water-jet cutting instruments:

- Cut the edges of the slab before performing any other operations in order to reduce the strain;
- Check that the work bench is perfectly flat and totally free of residues or debris;
- Ensure that the blades fitted to the work bench are in perfect condition and parallel at a minimum distance, to allow the slab to be positioned perfectly on the work bench;
- Check that the level of water in the machine is 2-3 mm above the level of the work bench, thus slightly floating;
- If the material is to be cut without holes it is wise to pierce the slab to be cut starting from the edge;
- When cutting materials in which holes have to be made, on the other hand, it is preferable to start piercing from inside of the hole and work towards the outside, curving slightly;
- Cut the holes at a distance of at least 5 cm from the edge of the finished countertop, and angled should have a minimum 5 mm radius;
- To avoid any breakages, holes should be cut starting from the centre of the slab, while any straight cuts must be started from the edges.

### Indicative working parameters:

- Abrasion 0.35-0.45 Kg/Min.;
- Starting pressure 600-700 bar;
- Cutting pressure 3500-3700 bar;

## 06.5 basic instructions and tips for using a CNC

Infinity recommends taking the following precautions when using a CNC system:

- Place the suction cups in such a way to allow slab to be positioned and supported in the best possible way;
- Holes must be made as far away as possible from other cuts or holes, considering a minimum distance of 5 cm from the start of the hole with respect to the finished countertop;
- Then start to cut the hole in the part far away from the corner, curving slightly from the initial drill hole (fig. 1);
- Start cutting in the part farthest away from the corner of the countertop and remove the blade from the initial drill hole.

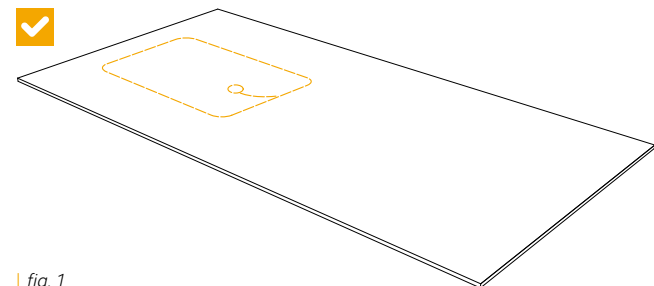

| fig. 1

### Drilling speed (35 mm diameter drill bit):

- Cutting speed 15-20 cm/minute. Chuck rotation speed 2000-2200.

### Cutting speed (end mill bit) to pass through the material with a diameter of 19-22 mm:

- Drilling speed 300-350 mm/minute. Chuck rotation speed 5000-5500;
- It is important to follow the tool instructions and bear in mind the diameter parameters of the mill and/or toothed profile grade, and to sharpen the tools frequently (roughly after every 4 holes).

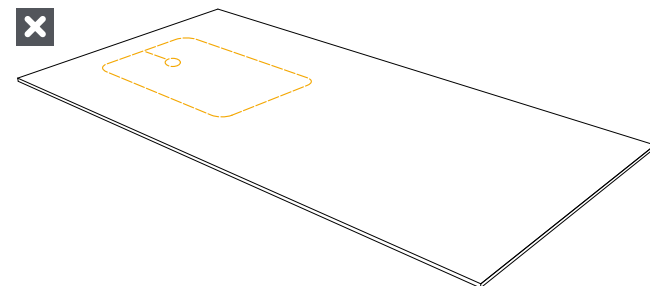

### Countertop cutting tool (or countersink mill)

Nominal thickness	Drilling speed mm/min.	Chuck rotation speed Rpm.	Max material removal
6 mm 12 mm 20 mm	300	6000	2 mm/revolution

## 06.6 cutting out holes

### Diamond-head tools

- Precise drilling of the edges around the hole. We recommend a diameter of at least 10 mm;
- Make the adjoining linear cuts with a bridge saw.

### Water-jet cutting tools

- It is preferable to start by drilling a hole in the centre to reduce the strain on the slab;
- Then proceed towards the desired perimeter of the hole, reaching up to the tangent;
- Proceed to cut around the edge of the desired hole, avoiding sharp 90° corners by maintaining a radius of roughly 10 mm.

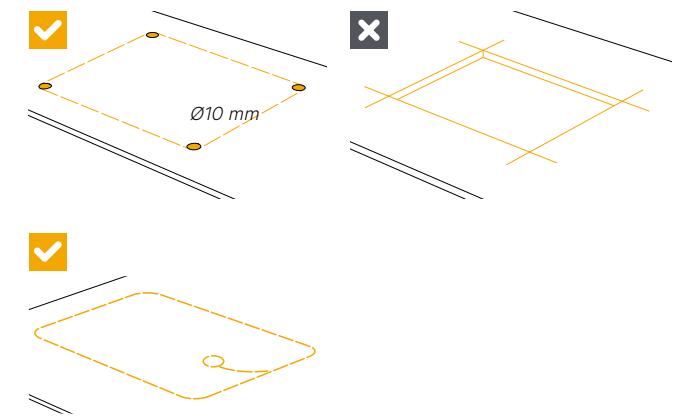

## 06.7 cutting L-shapes

Before performing any work, Infinity recommends cutting the edges by removing 20-30 mm of material from each side (fig. 1).

To avoid any extreme strain on the slab, never make any internal cuts in the material with a sharp corner at the interconnections.

With regard to L-shapes, after having accurately decided where the cut is to be made (fig. 2), it is a good rule to first drill the holes to reduce

the strain. In the slab in each of the internal corners of the L-shape (fig. 3). Then proceed to make the straight cuts (fig. 4-5), where a hand-held grinder can be used to finish off the cut nearer to the hole.

To conclude, Infinity recommends cleaning the surface with clean water. It is also important to remember that (fig. 6).

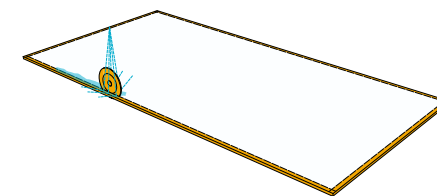

| fig. 1

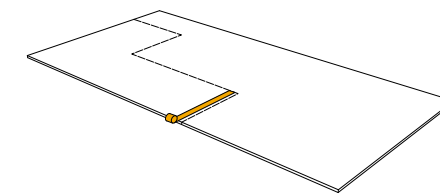

| fig. 2

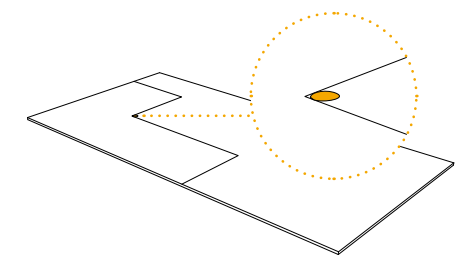

| fig. 3

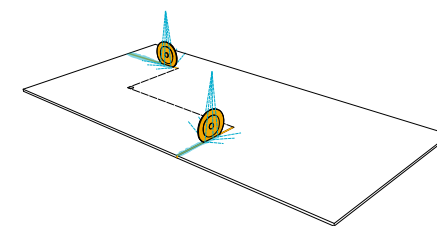

| fig. 4

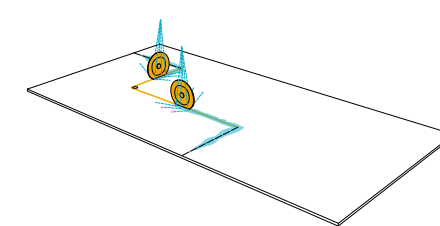

| fig. 5

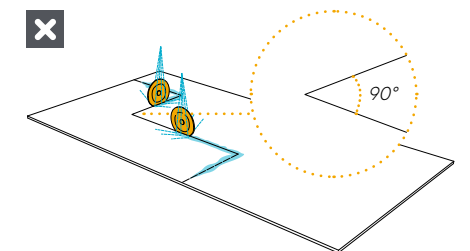

| fig. 6

# 06 | production processes

## 06.8 Cutting with diamond grinding tool

Infinity recommends cutting with diamond grinding tool to obtain non-linear shapes for basins (fig. 1), perimeter machining for kitchen tops (fig. 2-3) and "J" joints (fig. 4) between different slabs, in alternative to water-jet machining.

For best results Infinity recommends circular drilling of the entry point with a special circular cutter, to be positioned according to the chosen shape.

Then install the specific cutter for non-linear cuts on the CNC machine.

Align the grinder on the hole made and begin machining.

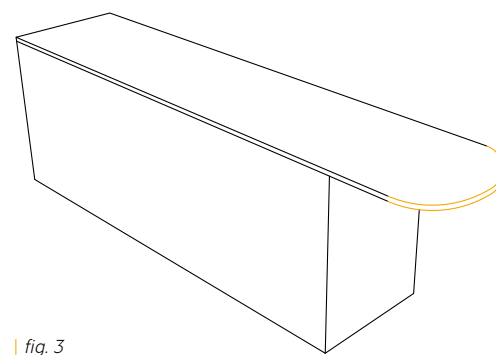
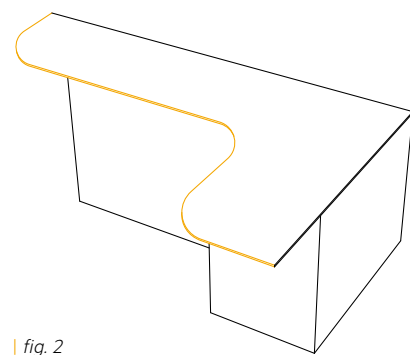
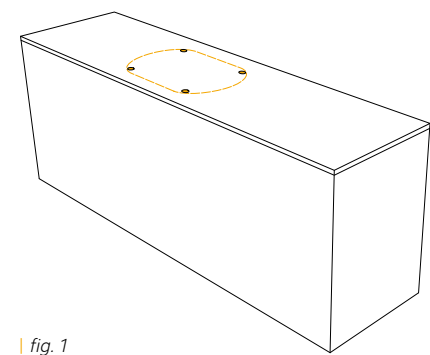
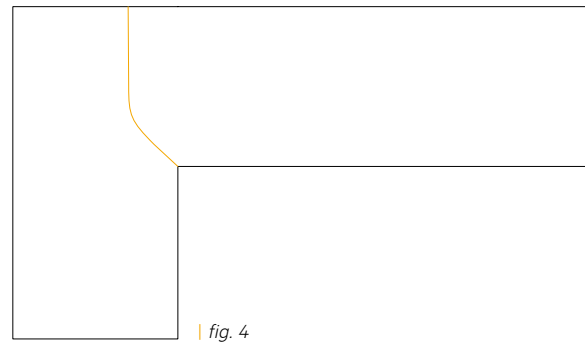

fig. 1

fig. 2

fig. 3

## 06.9 edges

Infinity recommends the following finishes for the creation of countertop edges:

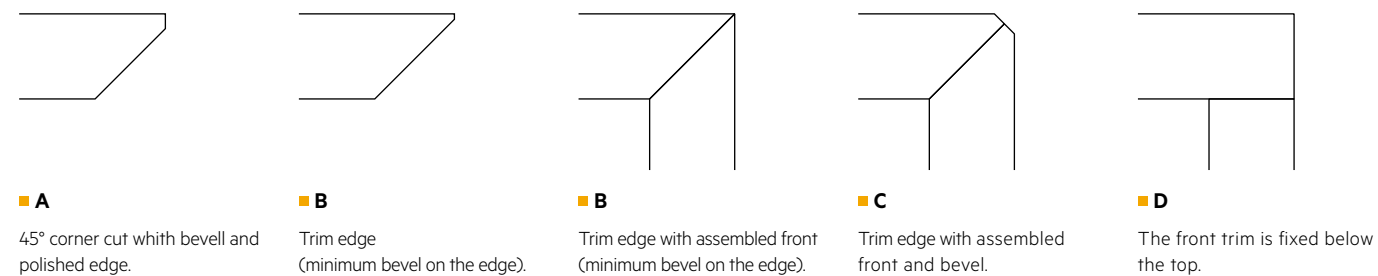

The type of edge finish will depend entirely on the chosen slab; in the case of rich colours and vein markings, for example, it is preferable to have a matching edge. For the best results, in the case of complex graphics, Infinity recommends finishing the slab according to **B** or **C**.

If the slab has a simpler colouring (for example in the case of plain colours), the type of edge finish is up to the customer to decide.

## 06.10 polished edge finishes

To reduce the risk of the edge chipping, we recommend bevelling the edges before applying the finish to the edges with the edge-polishing machine.

Follow the sequence of abrasives according to the surface and finish desired, in line with these parameters:

- Abrasive **satín** finish: 120-220-500;
- Abrasive **polished** finish: 100-200-500-1000-2000;
- Speed: 100/120 cm per minute

## 06.11 automatic polishing

Automatic polishing is done using special machinery available on the market from various manufacturers. It is used to create different types of edge profile which cannot be achieved using manual or craft processes. It is also used to precisely control the required degree of shine on the slab edge.

Depending on the profile to be obtained, the corresponding tool must be fitted on the automatic machine.

This finishing process is done downstream from cutting to obtain finished pieces ready for installation.

This process is recommended for 12 or 20 mm thick slabs.

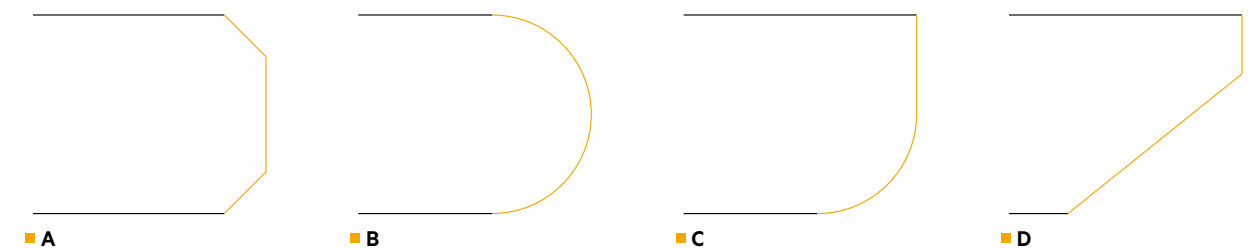

## 06.12 L-shaped countertops and joints

For L-shaped countertops, we strongly recommend not to cut the slabs diagonally but to simply arrange the slabs with a linear layout, using silicon for the joint.

For materials with uneven graphics or those with multiple vein markings, it is preferable to check carefully in advance how the elements can be arranged for the best overall result.

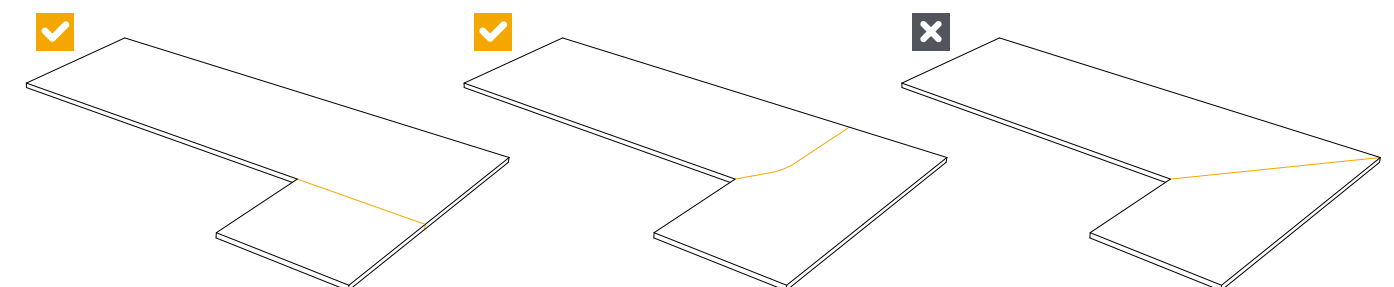

## 06 | production processes

### 06.13 cutting and drilling when laying

The following suggestions are provided for the correct laying of our slabs using traditional methods. The steps involved can be easily carried out on slabs with a thickness of 6 mm, and possibly also for greater thicknesses.

- It is firstly essential to carry out all cutting jobs on a perfectly stable and flat work bench (fig. 1);
- For straight cuts, we recommend using a guide fitted with a diamond cutting tool (fig. 2);
- To complete the cutting process and prevent the slab from breaking, we recommend using special cutting pliers (fig. 3);
- The slabs can also be cut using a dry or water-blade saw with a diamond disc (fig. 4);
- For L-shaped cuts or cuts inside the slab, Infinity recommends first drilling holes in the position marked for the vertices to prevent the surface from being damaged with the blade of the grinder (fig. 5);
- To cut out circular holes in the slabs, we recommend using a diamond drill bit with the desired diameter and to keep the surface constantly wet with water (fig. 6 - fig. 7);
- If it is necessary to make holes close to the edge of the slab, Infinity recommends leaving a minimum distance of 50 mm between the edge of the slab and the edge of the hole (fig. 8).

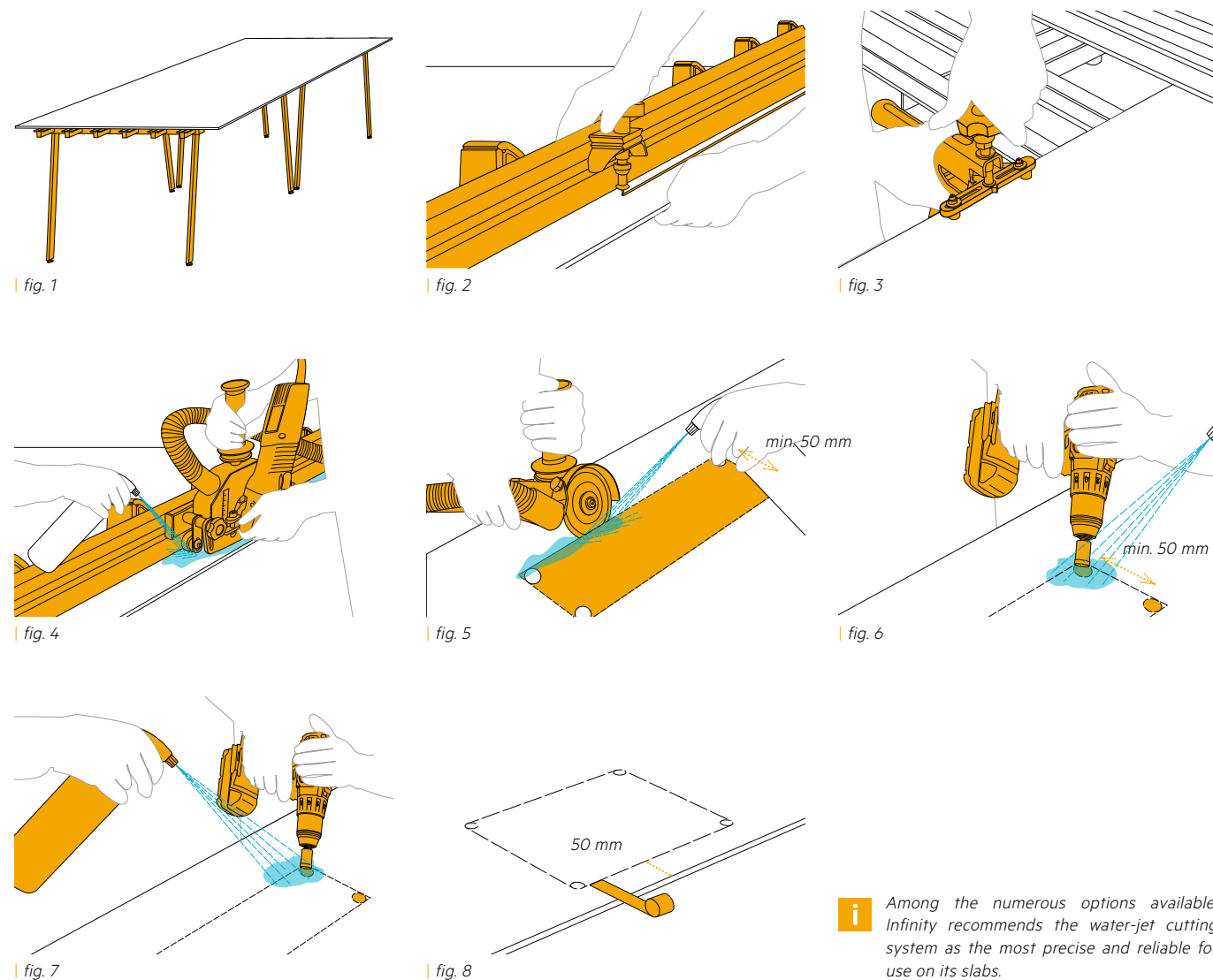

**i** Among the numerous options available, Infinity recommends the water-jet cutting system as the most precise and reliable for use on its slabs.

## 07 | laying instructions

### 07.1 installing a kitchen countertop

The countertop must be transported in a proper manner up to the place of installation. It must under no circumstances be walked over (even when still packaged), and it must be unpacked and handled in a vertical position. It is vital to make sure that the support base on which the countertop will be fitted is structurally solid and perfectly flat (fig. 1). We also recommend paying particular attention to the gluing phase, applying the adhesive evenly over the entire support surface to allow the slab to adhere perfectly. In this regard, it should be noted that in the short space of time after installation, factors such as the settling and weight of the furniture supporting the slab(s), heat and humidity, may cause levelling to change slightly. We therefore suggest a post-sales inspection a few months after installation to check, and if necessary adjust, the levelling of the countertop.

For a correct installation of the countertop, and to ensure adequate resistance of various types, it is important to follow the precise indications given below.

- **6 mm:** we recommend covering the entire surface of the support on which the slab is positioned with a rigid support polypropylene (or similar) (fig. 2). To counter any differences in expansion between the two elements, it is preferable to use an elastic adhesive;
- **12 mm and 20 mm:** it is possible to use a slatted structure with evenly distributed traverses around the entire perimeter (fig. 3). If one or several holes are planned for the countertop it will be necessary to reinforce those parts most subject to strain (fig. 4);

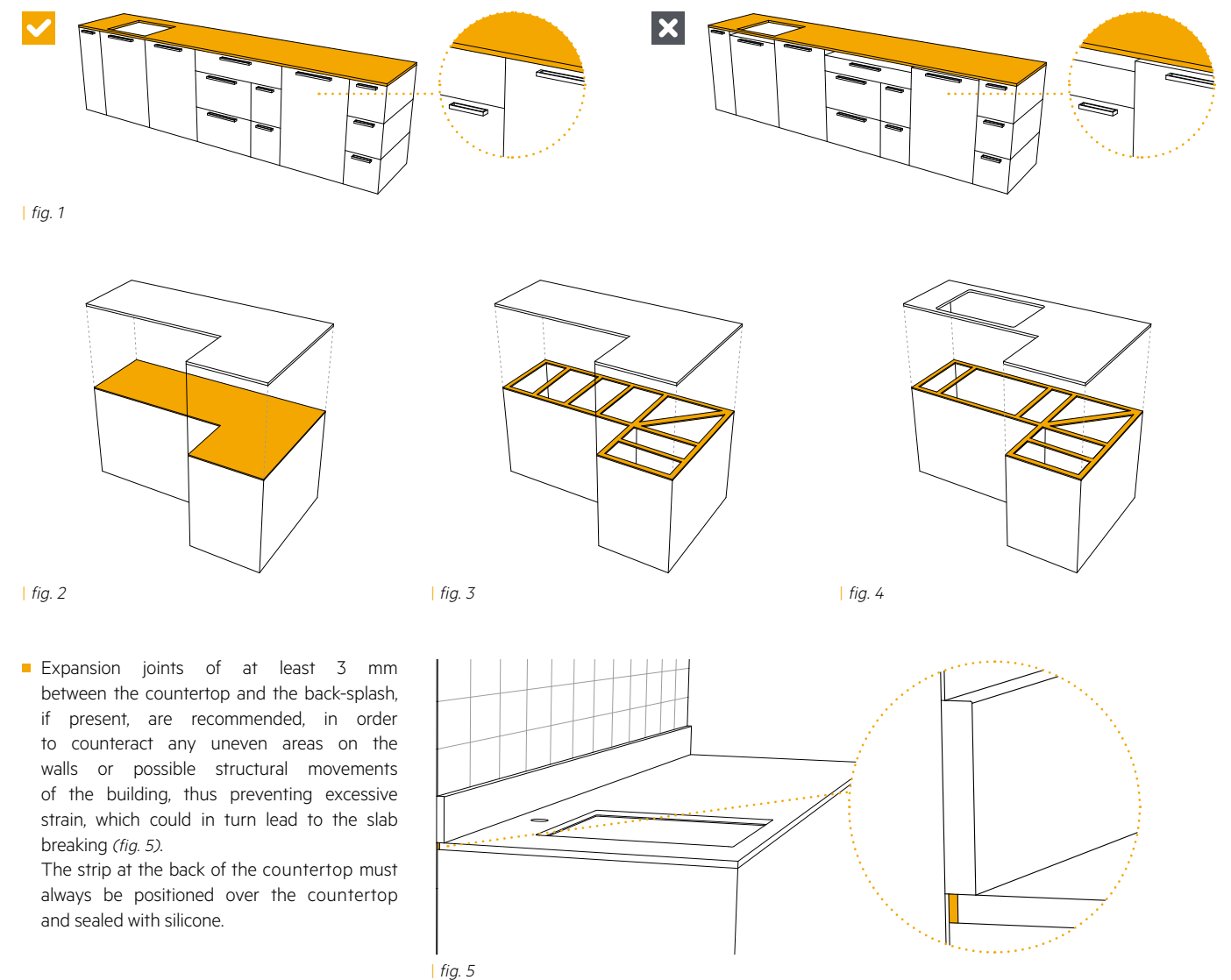

- Expansion joints of at least 3 mm between the countertop and the back-splash, if present, are recommended, in order to counteract any uneven areas on the walls or possible structural movements of the building, thus preventing excessive strain, which could in turn lead to the slab breaking (fig. 5). The strip at the back of the countertop must always be positioned over the countertop and sealed with silicone.

# 07 | laying instructions

## 07.2 installing a kitchen countertop: procedures

### Countertop for kitchen without wall cupboards

- Position the countertop vertically, leaning it against the wall of the kitchen units (fig. 1);
- Apply silicon evenly to the supporting crosspieces to ensure that the slab adheres perfectly (fig. 2);
- Place the countertop on the surface, slipping it into place (fig. 3).

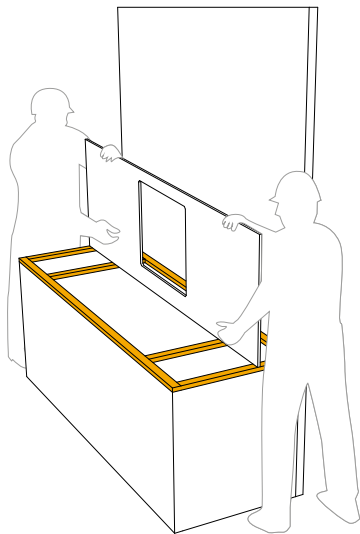

fig. 1

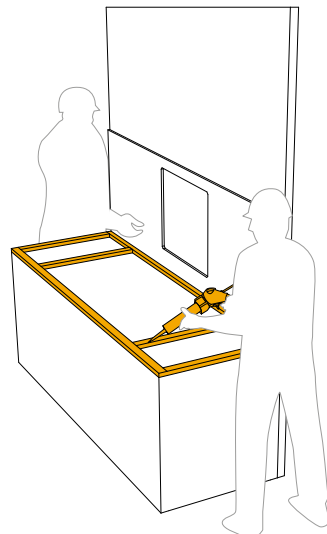

fig. 2

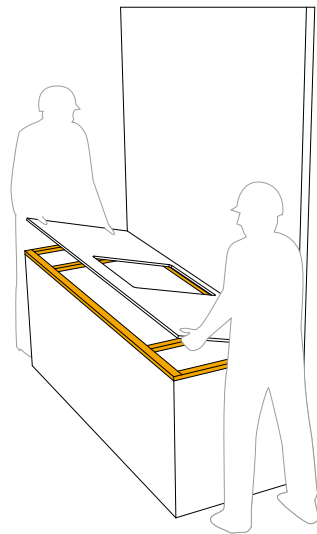

fig. 3

### Countertop for kitchen with wall cupboards

- Apply silicon evenly to the supporting crosspieces to ensure that the slab adheres perfectly (fig. 1);
- Position the countertop vertically to one side of the kitchen units (fig. 2);
- Hold the countertop over the surface, sliding it into place (fig. 3).

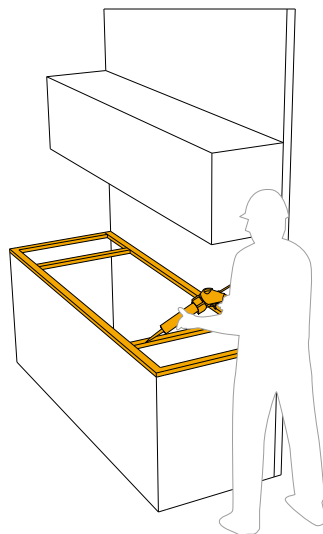

fig. 4

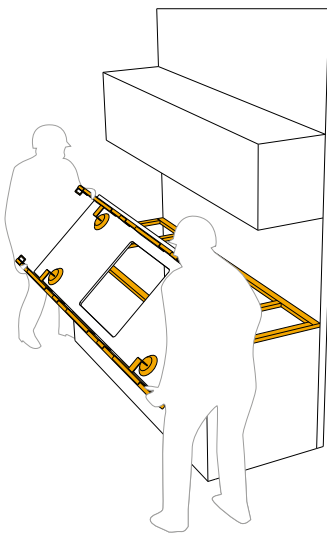

fig. 5

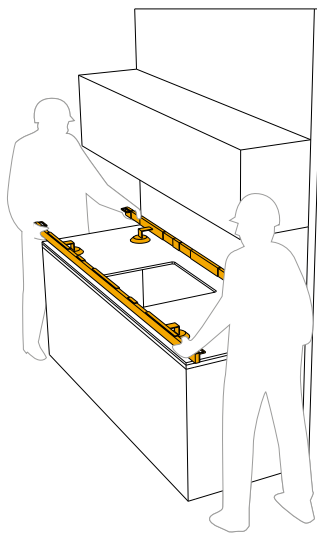
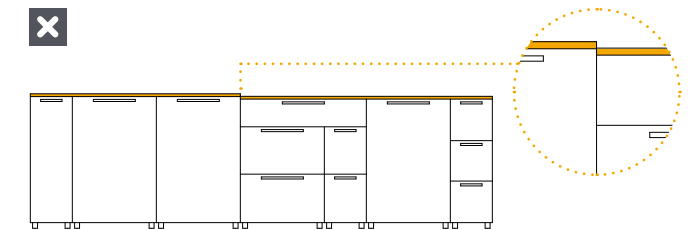
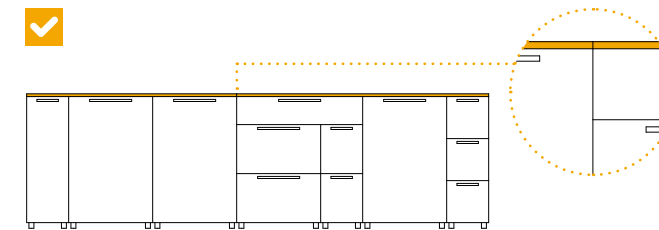
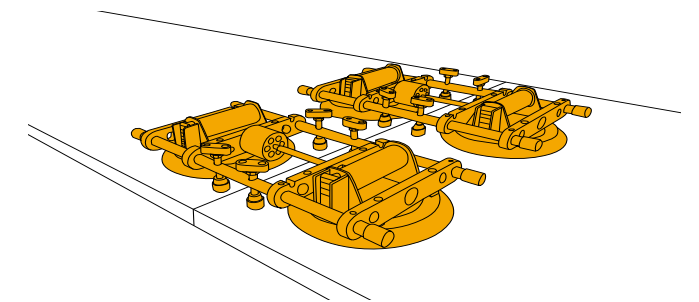

fig. 6

## 07.3 installing a kitchen countertop: adjoining elements

To avoid the elements from banging into or rubbing against each other, and to make it easier to join any pieces ready for laying, levelling elements may be used, which are removed only when applying silicone and for any subsequent final adjustments. The experience and professionalism of qualified layers and the care and attention required for the above-listed procedures are, however, absolutely essential.

To achieve precise, professional joints and reduce any risk of chipping when joining together the pieces, it is also wise to use suitable semi-automatic equipment fitted with suction cups.



## 07.4 over-hang

If the countertop is planned to have over-hang areas, it is essential to provide sufficient support, even when fixed to the wall (for example in the case of shelving). The possible size of the over-hang area will also depend on the presence of holes for sinks or hobs, and on the thickness of the slab used.

Infinity recommends following the values shown in the table below. Infinity recommends to not overload countertops and countertop's over-hang using heavy objects or standing on them.

Nominal thickness	6 mm + rigid support in polypropylene	12 mm	20 mm
Countertop with hole	200 mm	90 mm	200 mm
Countertop without hole	510 mm	200 mm	510 mm

# 08 | drilling holes for wash basin

## 08.1 minimum distance between the edge and the hole made for the sink

When planning a kitchen countertop with holes, it is essential to leave a **minimum distance of 50 mm** between the edge of the hole and the outer edge of the countertop.

The same minimum distance must also be left between adjacent holes.

Where possible, Infinity recommends making a single hole in each slab, so as to minimise any risk of breakage and not to excessively compromise the strength of the material.

To divide the sink into two, it is also possible to use offcuts.

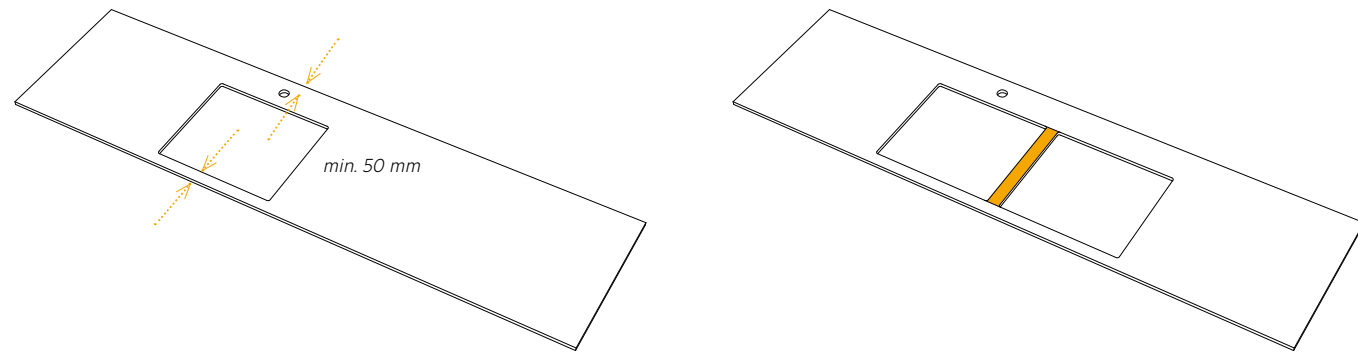

## 08.2 internal corners of a hole made to accommodate a sink

Each internal corner of a hole must have a **minimum radius of 5 mm**, where possible allowing a greater radius to give the countertop a greater structural resistance (fig. 1).

Infinity strongly recommends not to cut sharp angles, as this would strain the material and increase the likelihood of breakages (fig. 2 - fig. 3).

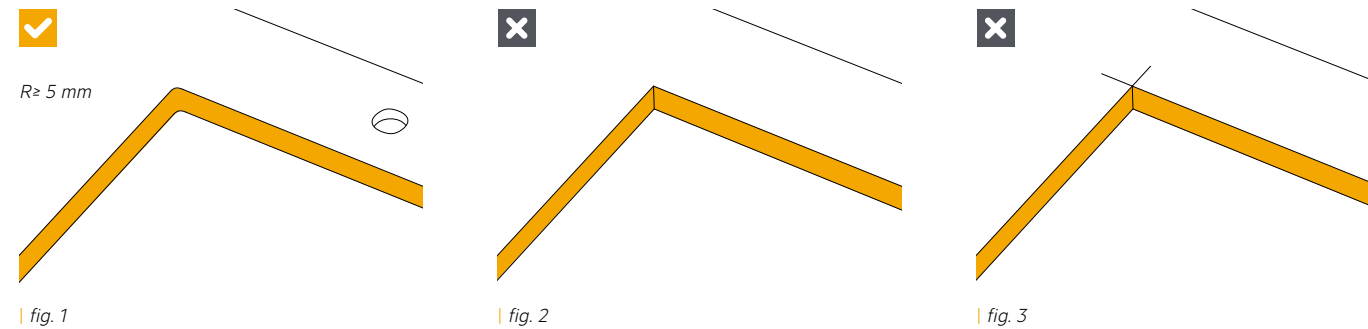

## 08.3 direction of the countertop during preparation

When preparing the countertop, Infinity recommends making the holes for the sink in the centre of the slab.

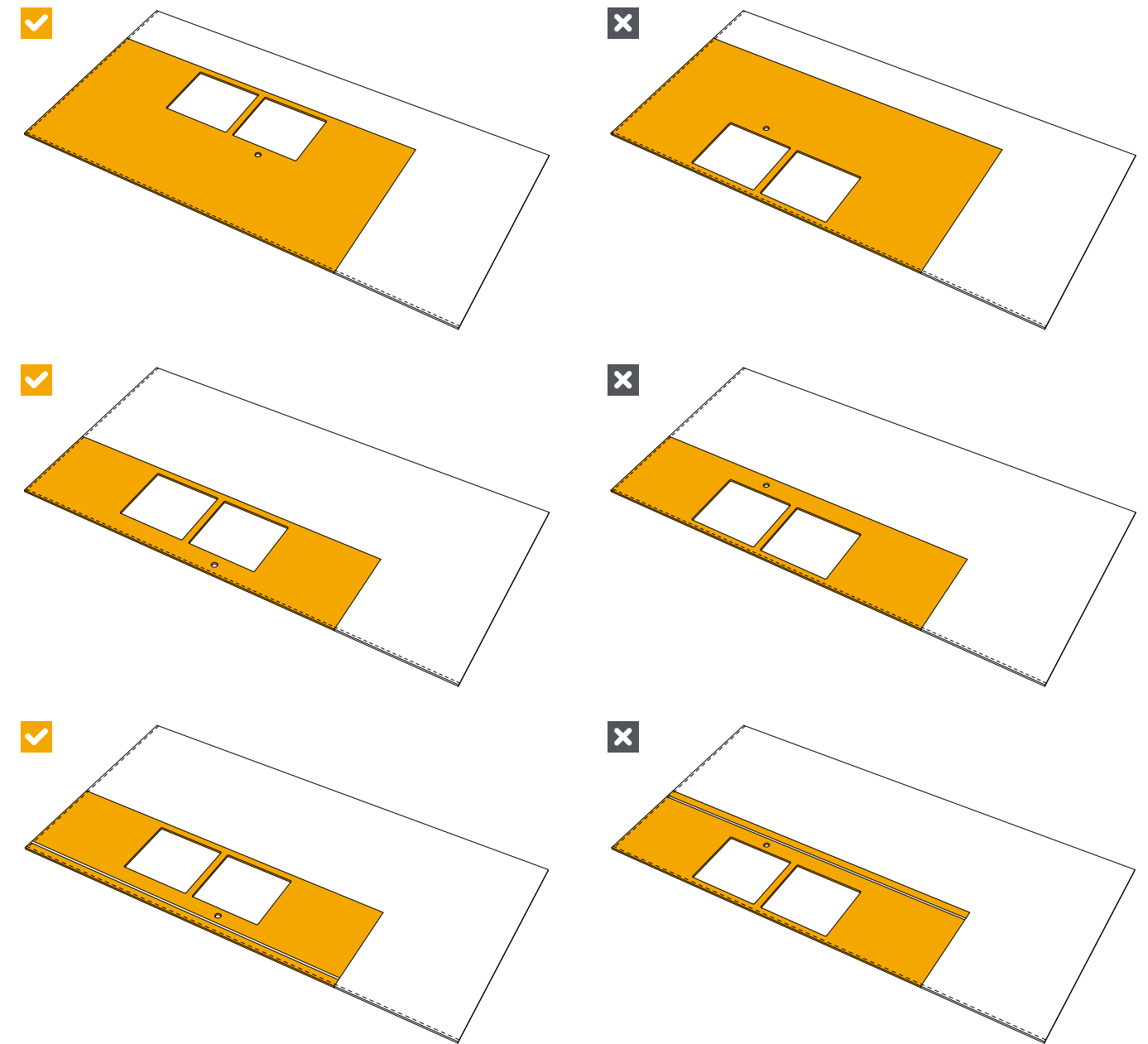

# 08 | drilling holes for wash basin

## 08.4 sink installation methods

The versatility of Infinity slabs makes them suitable for numerous types of sink installation.

### Drop-in

Is the most wide-spread and easiest method of installing a sink. The sink is a few millimetres higher the countertop.

To counter any thermal expansion, Infinity recommends leaving a distance of at least 2 mm between the sink and the countertop.

When mounting a sink, it is essential to seal all around the sink with silicone, protecting the surface of the countertop with masking tape.

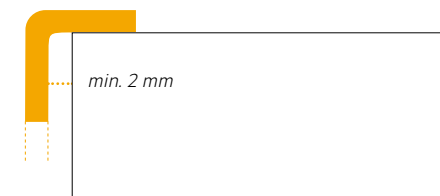

To ensure that the water-holding capacity of the sink is sufficient when full, in the case of **flush-mounted** and **undermount** installation we recommend attaching a supporting structure to the base unit. In this way, the weight will be borne by the underlying structure and not by the countertop itself (fig. 1).

Infinity also recommends reinforcing the perimeter of the sink (using an epoxy resin adhesive) using offcuts (fig. 2).

### Flush mount

Suited only on slabs with a thickness of 12 mm or 20 mm, this is a very elegant and extremely practical solution from a hygienic viewpoint, which requires particular attention during assembly.

The installation of sinks flush with the countertop leaves no raised edges, as they are inserted into a hole in the countertop with a depth of about 2 mm.

When mounting a sink, it is essential to seal all around the sink with silicone, protecting the surface of the countertop with masking tape.

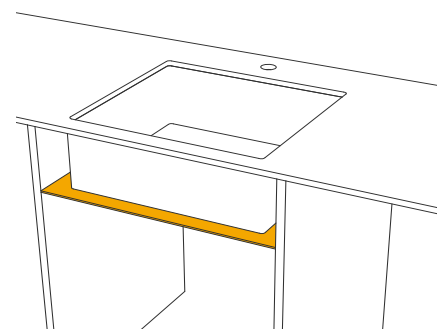

fig. 1

### Undermount

Suited only for slabs with a thickness of 12 mm or 20 mm, undermount installation leaves no edges visible, allowing an elegant continuity between the countertop and the sink.

To minimise the risk of chipping, we recommend bevelling the edge of the slab (around the hole) with a minimum radius of 2 mm.

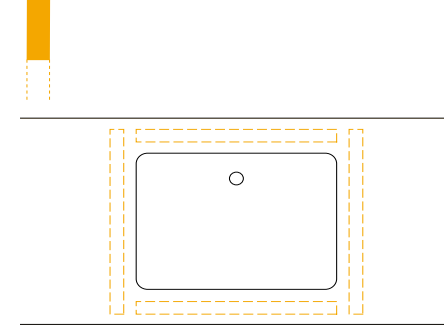
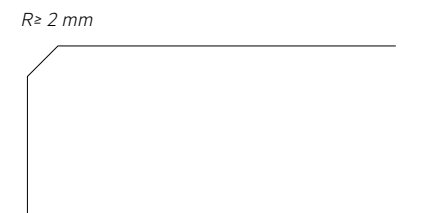
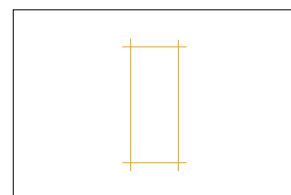
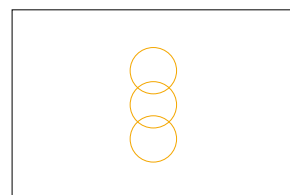

fig. 2

## 08.5 accessories for other fixtures

For any accessories needed for the other kitchen fixtures, we recommend making various round holes.



## 08.6 inserting the bushing

To make under-mount sink fittings, it is possible to make a series of holes to house threaded bushings to fix the sink mechanically, in addition to gluing, which alone could be insufficient in terms of sealing (fig. 1 - fig. 2).

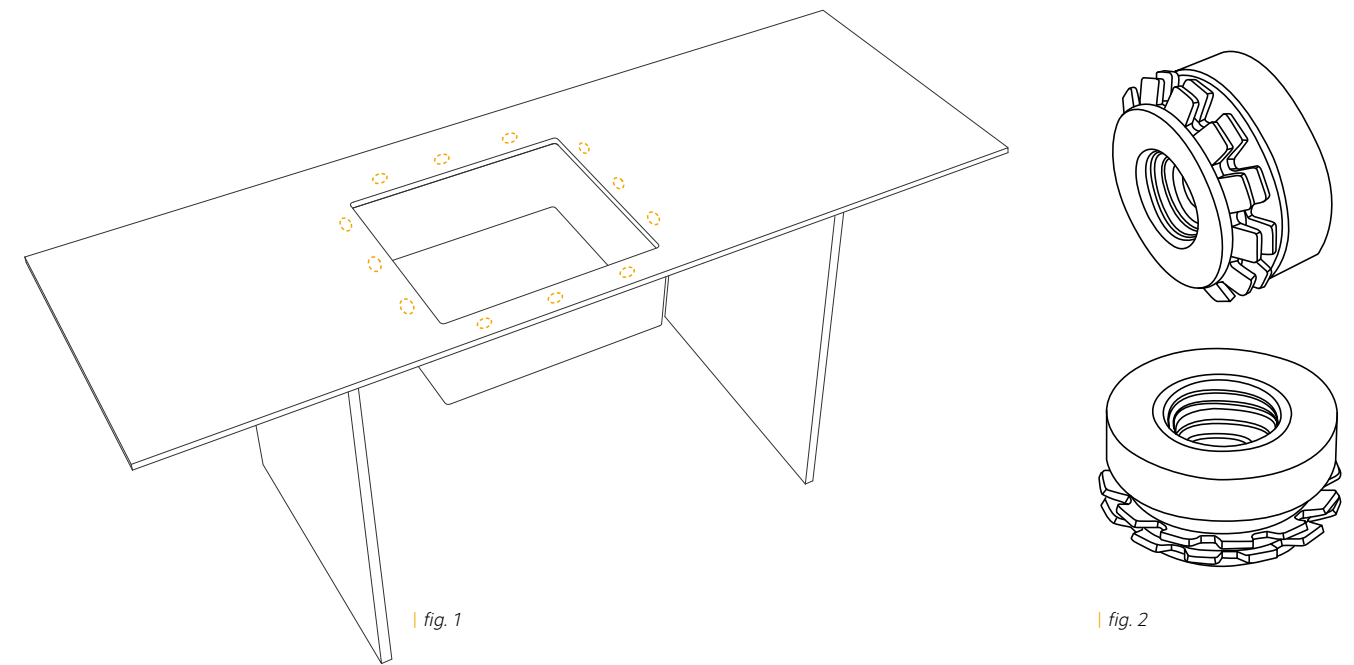

fig. 1

fig. 2

This can be done with a CNC machine. Infinity recommends the use of a specific diamond tip drill, taking great care with the hole depth, according to the thickness of the slab, to avoid accidental breaks during machining (fig. 3).

It is also important to use NON-expanding bushes, as they are unsuitable for application on porcelain stoneware slabs.

After inserting the bush in the hole, proceed to fix it completely using a rubber hammer (fig. 4).

This processing can be done on 12 or 20 mm thick slabs.

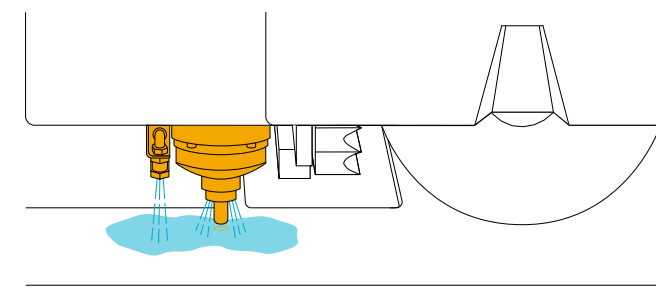

fig. 3

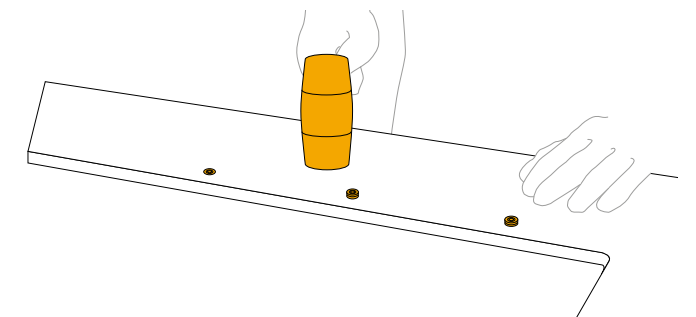

fig. 4

# 09 | assembling 45° edging

## 09.1 assembling 45° edging with pre-mixed coloured epoxy glue

This type of assembly is facilitated by the fact that the epoxy glue is supplied by the manufacturer in a colour that matches the chosen Infinity slab. This is a category of products available on the market from several

manufacturers, each of which has developed precise colour combination tables, which link a certain glue to a specific colour in the Infinity range, to make it easier to identify the glue colours that match the chosen surface.

Infinity recommends the following assembly sequence:

- Before applying the epoxy glue, clean all the gluing surfaces very carefully (fig. 1).
- Cover all surfaces that will remain on view with rubber paper, along the edge of the profiles to be glued, in order to protect the surface areas and make cleaning easier after assembly (fig. 2).
- Having identified and prepared the epoxy glue dispenser, eliminate the first 5 cm of glue to be sure that the product applied is well mixed (resin and catalyst) and has a uniform colour (fig. 3).
- Then proceed to spread the glue on the surfaces to be coupled (fig. 4).
- Then lock the 2 pieces with special clamps which must remain in place for the required drying time (fig. 5).
- Having positioned the clamps, promptly remove any excess glue (fig. 6).
- After drying, remove the clamps (fig. 7) and proceed to finish the corners using the special PADS installed on angle grinders (fig. 8).
- After this operation remove the rubber paper (fig. 9) and proceed with the final cleaning of the assembled top (fig. 10).

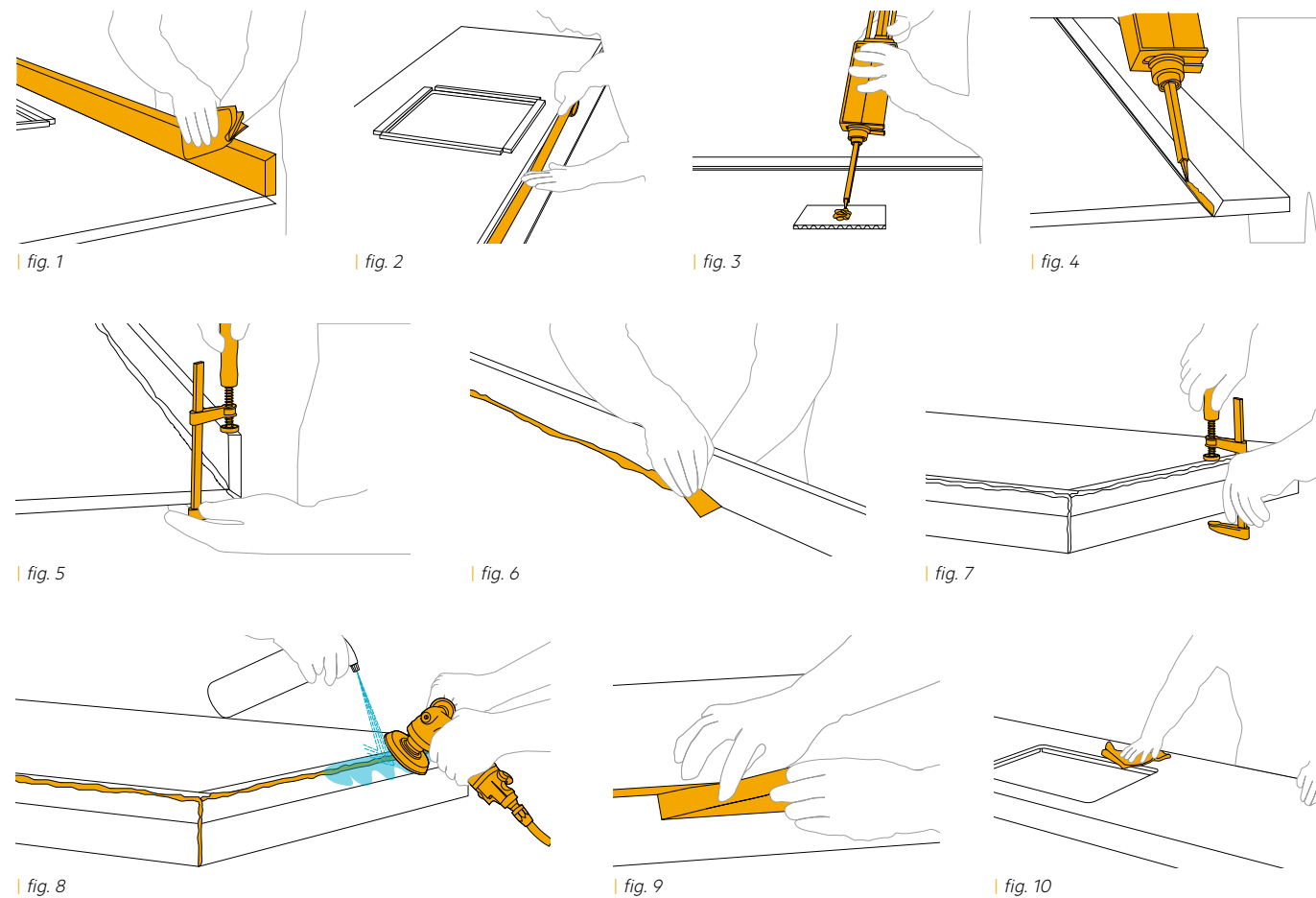

## 09.2 assembling 45° edging with specific colour preparation

The assembly process recommended by Infinity is the same as that given for pre-mixed epoxy glues.

In this case, take great care when mixing the colour to be applied, by correctly mixing the base colours (fig. 1).

It is also important to check the glue drying time carefully, as indicated in the product data sheet supplied by the manufacturer.

Usually these glues dry slower, and so are suitable for complex assemblies requiring different adjustments before reaching the final configuration. In any case refer to the specifications of the manufacturer for best results.

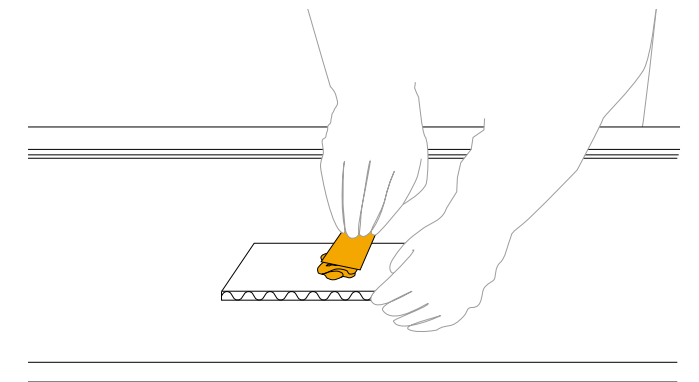

fig. 1

# 10 | joints

Before fitting the Infinity slab(s) into place, it is necessary to check that the supporting surface is perfectly level and flat. If this is not the case, we recommend using spacers or other adjustments to prevent the material from chipping.

To achieve a perfectly fitted countertop, it is essential to carry out all steps with the utmost care and attention; we thus recommend **lightly bevelling** all edges of the slab. Any joints must be made using silicon-based grouting in a shade that best matches the surface finish of the

chosen slab, whilst we advise against the use of epoxy adhesives or equivalent. Infinity also points out the importance of scrupulously complying with the hardening and drying times of the adhesive, according to the manufacturer's instructions provided.

It is always vital to provide customers with samples of edge finishes and joints for the countertop.

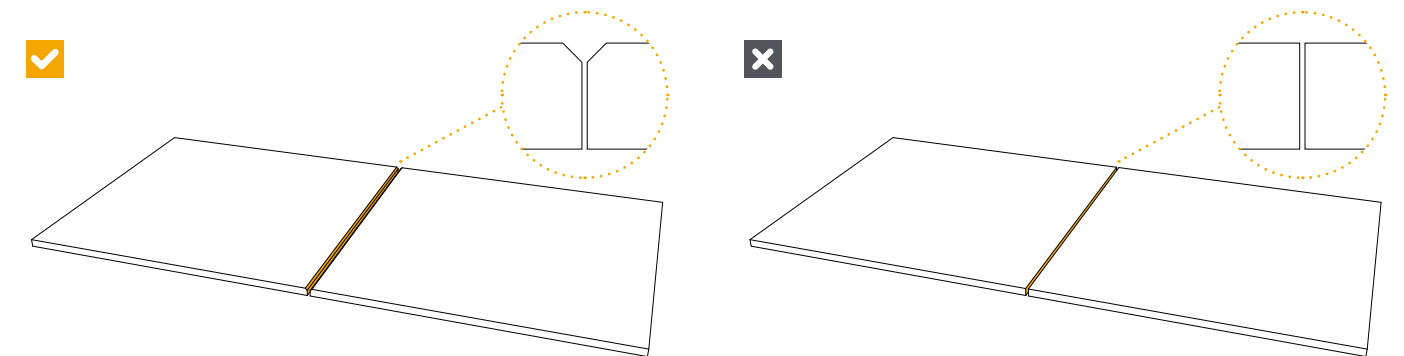

For flooring or wall coverings in indoor areas, only **rectified slabs** must be used. Joints should be minimum 3 mm; we recommend in any case referring to the guidelines given in the UNI11493 standard.

## 11 | edge colouring

The Infinity slab range is generally characterised by its great colour consistency between the mixtures and the surfaces, Infinity therefore recommends this treatment for the few colours in the 6 mm thick range, which have slightly greater colour differences between the surface and thickness of the slab.

Infinity recommends this application for uniform colour of the slab edge and surface, when the chosen installation leaves the edge on view.

The colourings are sold by different companies on the market. Infinity refers to the product data sheets of each supplier for precise application instructions.

The product may be spread using a clean cotton cloth (fig. 1).

After application remove any excess product and clean carefully. Repeat the procedure several (n) times to obtain the required results.

If the treated area is cleaned frequently, it may be necessary to repeat the treatment over time. Infinity refers to the product data sheets of each supplier for precise instructions.

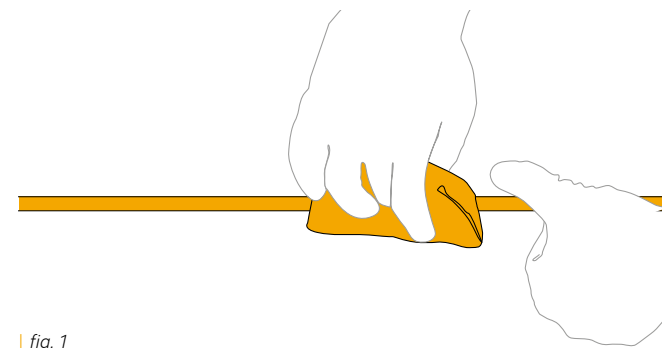

fig. 1

## 12 | support panels

With regard to the thickness of the Infinity slabs and the layout of the kitchen countertop, we recommend using a suitable support.

The support base on which the Infinity countertop is to be placed must be **fully flat, levelled and structurally solid**. In addition, the surface of the countertop must rest fully on the support, as any areas that are not supported from below might cause fragility and breakages. Therefore, it

is necessary to apply the adhesive (with high mechanical characteristics and elasticity) over the entire support, making sure that the support and the countertop are perfectly joined together (by simply applying spots of silicone here and there is not enough to guarantee a correctly fitted, resistant countertop).

Types of support panel recommended:

### ■ Marine-grade plywood

Wooden materials.  
Thicknesses between 10 and 30 mm.  
Standard support panel size:  
2500x2000 mm.

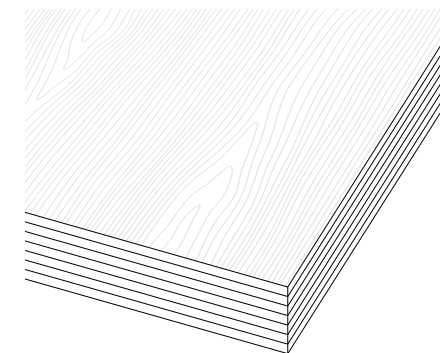

### ■ Honeycomb panel in aluminium, with hexagonal cells structure

Thicknesses between 3 and 30 mm.  
Standard panel size:  
from 1250x2500 up to 2000x7000 mm.

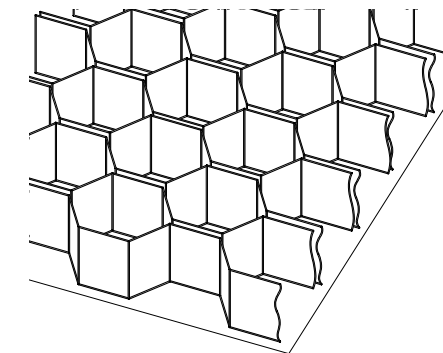

### ■ Extruded polystyrene

Thicknesses between 4 and 30 mm.  
Standard panel size:  
from 1250x600 up to 2500x900 mm.  
Pre-cut L-shaped and U-shaped panels are also available.

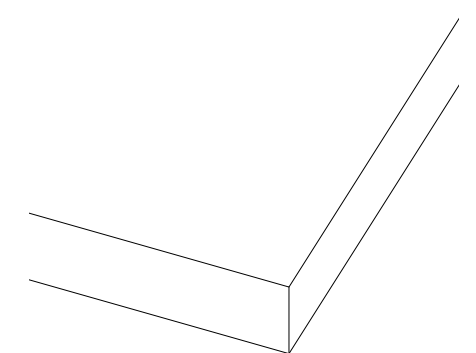

 For specific, more detailed information, please contact the Project Division of Infinity.

# 13 | adhesives and grouting

In relation to the different types of application, Infinity slabs are compatible with most commercially available adhesives and grouting. Based on the final application, we recommend the following product categories:

■ **Mounting on support panels (such as marine-grade plywood, extruded polystyrene, honeycomb structure in aluminium)**

Adhesive: 2-COMPONENT POLYURETHANE adhesive with a high degree of elasticity (minimum category pursuant to EN 12004: R2).

Grouting: Silicon grouting in a matching colour.

■ **For flooring or wall cladding**

Adhesive: pursuant to the EN 12004 standard.

	without mesh	with mesh
indoor	C2TES1	C2ES2
outdoor	C2TES2	R2T

■ **Mounting between components in porcelain stoneware (such as front trims and 45° edges)**

EPOXY RESIN adhesive in a colour to match the Infinity slabs.

Grouting: we recommend the use of a cement-based grout in the category CG2WA pursuant to EN 13888.

**For flooring or wall cladding, only rectified slabs must be used.**

Joints should preferably be no less than 3 mm; we recommend in any case referring to the guidelines given in the UNI11493 standard.

# 14 | laying in contact with heat sources

## 14.1 countertops with induction hobs

The Infinity slabs are perfectly suited for use in kitchen countertops with **induction hobs**, and provide an excellent solution from a technical and aesthetic viewpoint. The material is fully fireproof and has a linear thermal expansion coefficient of  $\alpha=6 \times 10^{-6} \text{ C}^{-1}$  pursuant to the standard EN 10545-8, in addition to the thermal shock resistance required by standard EN 10545-9.

To ensure correct installation, the minimum distance between the countertop and the induction hob is 2 mm (fig. 1), which must subsequently be sealed with a suitable thermal silicon (fig. 2).

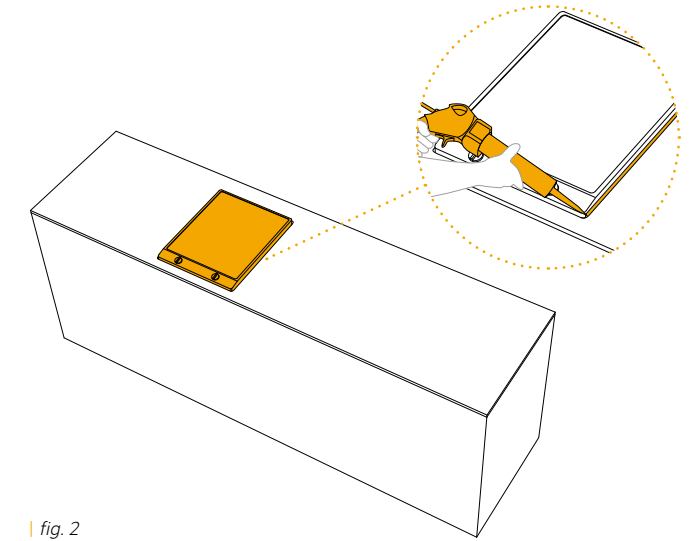
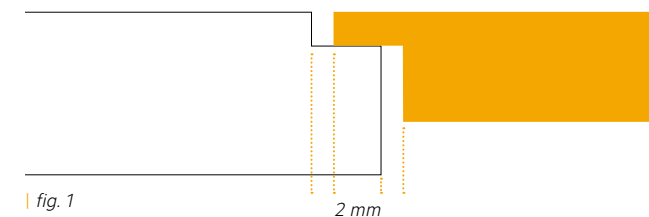

## 14.2 grills and barbecues

If grills and/or barbecues are built into Infinity countertops, the following aspects must be examined:

- Consider the thermal expansion of each material owing to variations in temperature, as too little or too much space would lead to a significant strain on the slab;
- It is therefore important to prevent the Infinity slab from coming into direct contact with the grill (or barbecue) by allowing a suitable amount of space in proportion to the size of the appliance and the high temperatures that can be reached and consequently spread to the surrounding area (fig. 1);
- Fill the joint between the slab and the grill (or barbecue) with thermal insulation or silicon (fig. 2);
- Carefully smooth the edges around the hole made to accommodate the appliance to remove any minor cracks made when cutting the countertop;
- Consider a minimum radius of > 5 mm for each internal corner;
- If the design layout allows, make a countertop by joining several elements with adequate joints, in order to create less strain and make it more resistant (fig. 3).

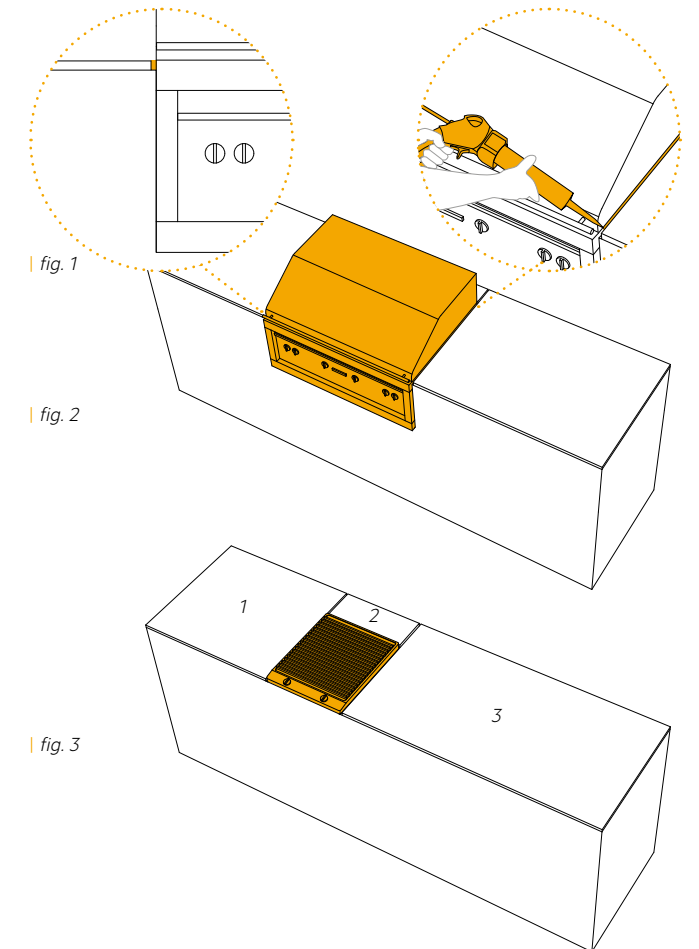

**i** For specific, more detailed information, please contact the Project Division of Infinity.

**i** For specific, more detailed information, please contact the Project Division of Infinity.

## 14 | laying in contact with heat sources

### 14.3 fireplaces

Infinity slabs are perfectly suitable for covering the **front, side or upper part** and in general all the outer parts of the fireproof material used to create fireplaces (fig. 1 - fig. 2).

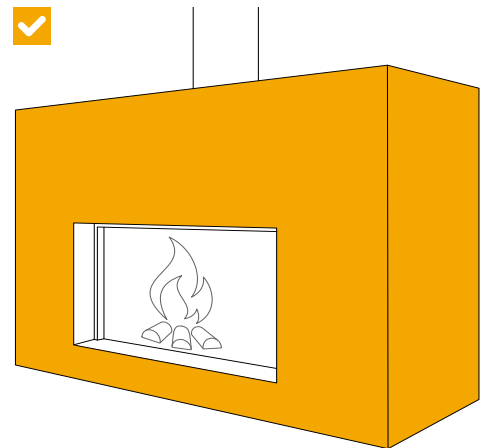

fig. 1

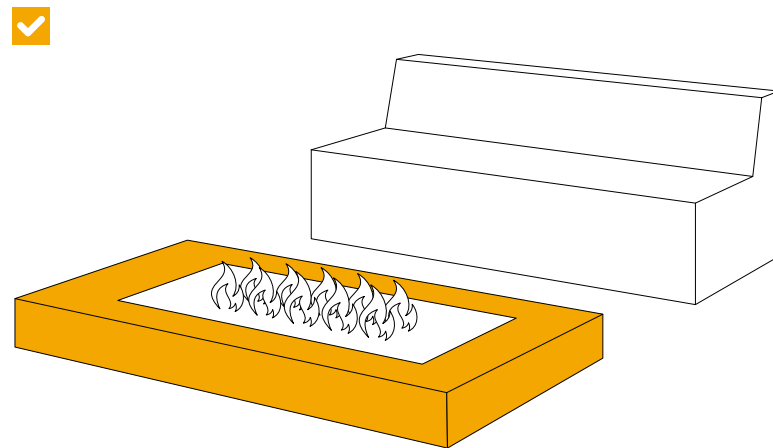

fig. 2

Infinity strongly recommends against the use of slabs to cover the areas in which heat is produced, or areas in direct contact with the heat, such as the **inner walls** or **the base** of the fireplace (fig. 3 - fig. 4).

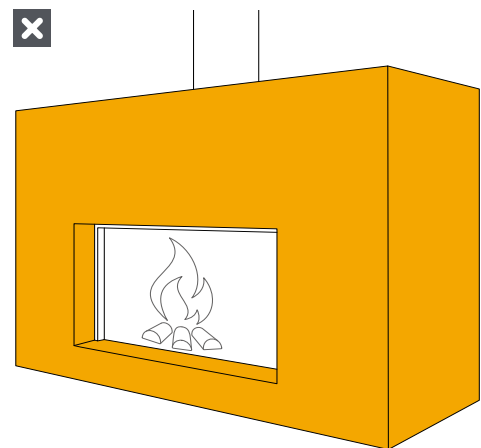

fig. 3

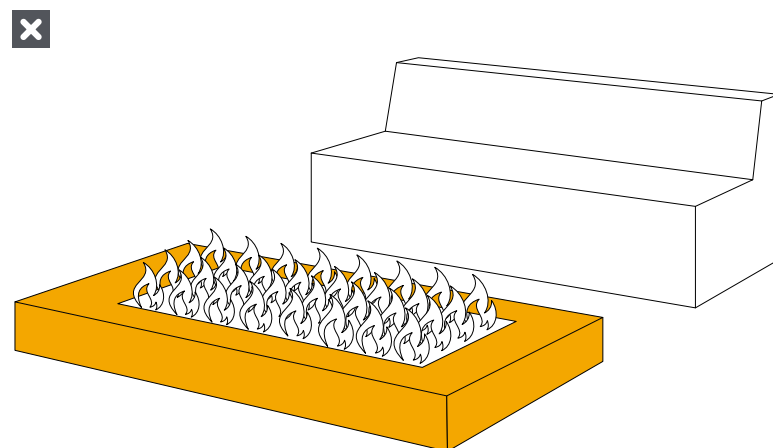

fig. 4

## 15 | cleaning and maintenance during laying

### 15.1 cleaning the countertop

For ordinary cleaning, a cloth dampened with water and neutral soap is perfectly adequate.

For more persistent or burned-on stains, we recommend moistening the dirt with hot water (to soften any residues) and then rinsing or removing with a clean cloth. It is also preferable to use a sponge with soft fibres of the type normally used for cleaning glass ceramic and glassware in general. Particularly abrasive sponges or steel wool must be avoided at all costs.

Infinity recommends against treating the slabs with caustic soda or products with a pH value above -1. If bleach is used, rinse with plenty of water and never leave the product to remain in contact with the surface of the Infinity slab.

For the correct maintenance of the slabs, Infinity recommends that you abide by the following precautions:

- **Always use pan stands, coasters and napkins;**
- **It is wise not to cut foods directly on the countertop but to use chopping boards for this purpose;**
- **Never drag household appliances, knives and utensils in general across the countertop, as this may leave steel stains that are difficult to remove;**
- **Never use ceramic knives directly on the countertop.**

### 15.2 floor cleaning

After laying the material it is essential to clean them thoroughly. If residues of grouting are not removed properly or quickly, this may result in stains that are difficult to remove and may create a film of concrete on the floor that traps all kinds of dirt.

To efficiently remove any residues of cement-based grout, it is essential to wash the floor with a solution of water and buffered acid, following the percentages of water/acid indicated on the packaging of the product used. Allow the detergent to work for a few minutes without letting it dry out, then wipe over the floor with colourless cloths (remove any residues with a stiff brush). Finally rinse with plenty of water and repeat the operation as necessary.

#### 15.2.1 ordinary floor cleaning

Infinity recommends against the use of oily soaps and waxes, and recommends instead neutral detergents such as ammonia or bleach, that have been suitably diluted in water. After washing, the floor should only be dried if it has a polished finish (to avoid any visible stains from appearing).

We always recommending testing any detergent before use, always following the instructions and the precautions indicated by the manufacturer

#### 15.2.2 extraordinary floor cleaning

In the case of residues and stains that are particularly stubborn and difficult to remove, Infinity suggests cleaning the surface first with warm water and neutral detergents.

For persistent stains, then use more intense cleaning methods using specific products (depending on the type of stain to be treated):

- **Non-abrasive detergents with a neutral pH;**
- **Slightly abrasive detergents;**
- **Acid or alkaline detergents;**
- **Solvent-based detergents.**
- **3M Scotch-Brite sponge.**

We recommend always following the instructions and precautions indicated by the manufacturer.

# 15 | cleaning and maintenance during laying

## 15.3 cleaning products

TYPES OF DETERGENT Where sale is permitted	SOLVENTS (bleach, turpentine, acetone, trichloroethylene, nitro thinner)		ACIDS (muriatic acid, hydrochloric acid, phosphoric acid)		ALKALINE-BASED DETERGENTS - ALKALI (professional alkaline detergents)	
	Matt - Satin	Polished	Matt - Satin	Polished	Matt - Satin	Polished
<b>TYPES OF STAIN</b>						
Beer				■	■	
Coffee		■				
Lime scale			■	■		
Tar	■	■				
Concrete			■	■		
Candle wax	■	■				
Coca Cola		■				
Glue	■	■				
Chewing gum	■	■			■	
Rubber marks from tyres or shoes	■	■				
Grease, Oil					■	■
Ink	■	■				
Nicotine	■	■				
Felt-tip pen	■	■				
Tomato		■				
Resins	■	■				
Rust			■	■		
Nail varnish	■	■				
Cigarette burns			■	■		
Tea		■				
Wall paint	■	■	■	■		
Red wine		■				

**i** In view of the technical characteristics of the material, we recommend first trying to remove any stain using hot water, and to resort to specific products only if the result is not satisfactory.

For information and advice, please contact Infinity directly.

# 16 | scratch repairing

## 16.1 Infinity scratch repair kit

In case polished countertops present scratches on the surfaces not excessively deep, it is possible to reduce or repair them using specific filling treatments. A professional operator must verify the extent of the scratch to define the effective possibility of restoration.

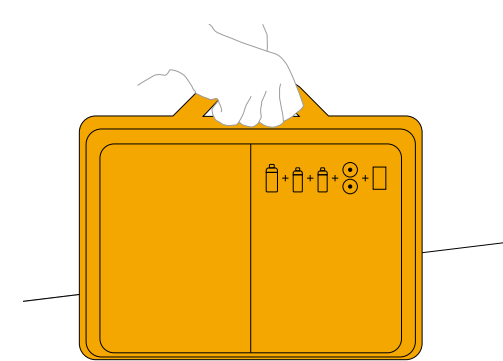

fig. 1

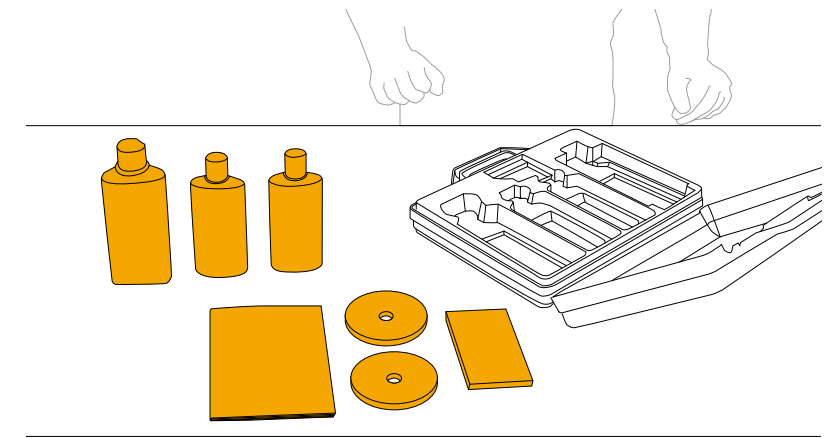

fig. 2

### APPLICATION STEPS:

- Carefully clean the countertop taking care to remove dust and dirt on the surface;
- Protect adjacent surfaces on which you do not intend to apply the treatment;
- Apply the water-based filling product to the area to be treated, using an automatic monobrush with a white pad, making concentric circular movements along the direction of the scratch and without applying excessive pressure, taking care to treat the whole surface uniformly;
- Repeat the operation until the desired result: check the surface and evaluate the result between one application and another;
- Once finished, remove product residues and rinse thoroughly with water.

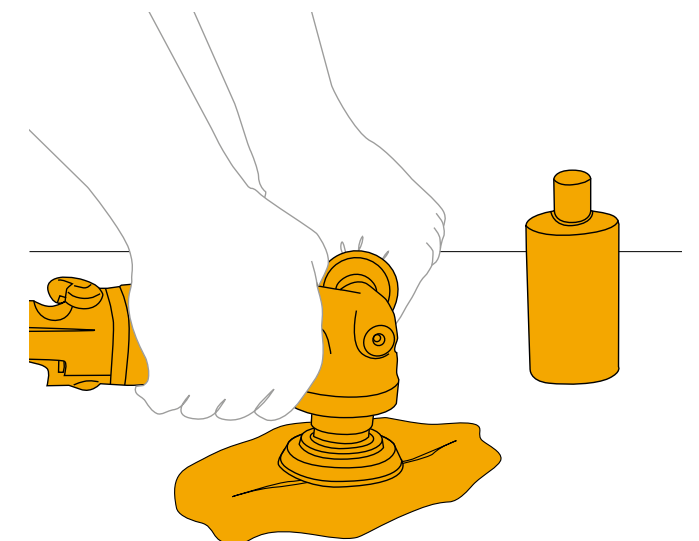

fig. 3

# 17 | chip filling

## 17.1 chip filling

Infinity surfaces are extremely hard, which makes these work surfaces extremely resistant to many types of impacts. However, particularly on the edge, over time, with wear small chips may appear following accidental impacts with weights or objects of comparable hardness (e.g. glass).

Considering the size of the slab and the intrinsic difficulty in replacing it, Infinity has adopted a repair kit, with a view to offering further solutions for the end customer having to deal with this type of problem.

The repair procedure is as follows:

- lightly grind the chipped point (fig. 1);
- clean the area carefully after grinding (fig. 2);
- using the base colours in the kit prepare a resin of the same colour as the slab, mixing the colours and progressively achieving the shade of the damaged top (fig. 3);
- having obtained the required colour, prepare the applicator supplied in the kit with the resin (fig. 4);
- mix the compound and the colourant prepared earlier (fig. 5);
- fix a plexiglass slide to the slab with clamps, in the damaged area (fig. 6);
- push the prepared bi-component compound with a spatula (fig. 7);
- when dry, remove the plexiglass slide. The resulting surface will be similar to the Polished surface, for Matte/Opaque finishes, lightly sand (fig. 8).

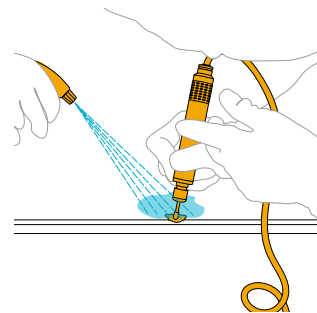

fig. 1

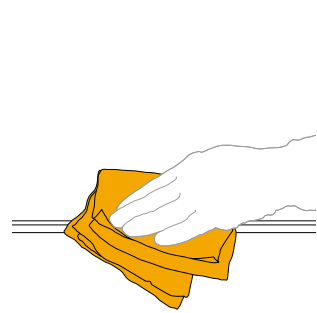

fig. 2

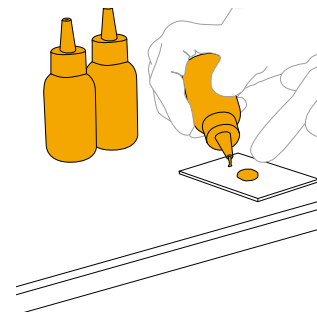

fig. 3

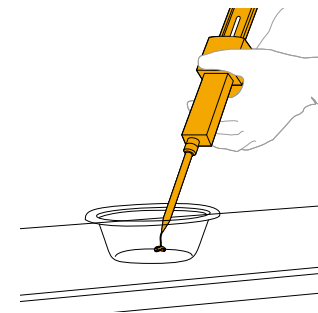

fig. 4

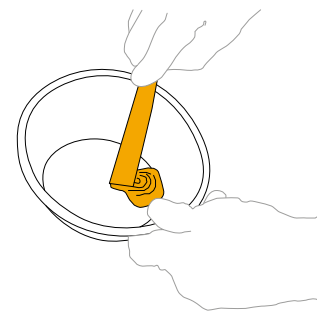

fig. 5

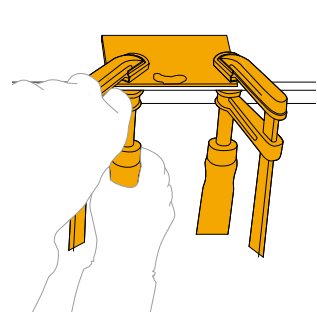

fig. 6

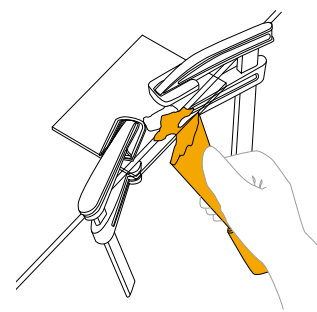

fig. 7

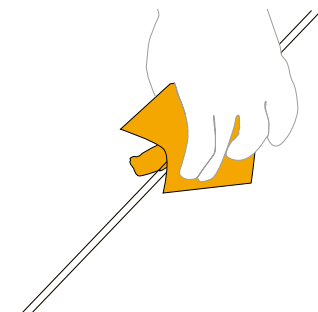

fig. 8

# 18 | technical characteristics

## STANDARD EN 14411 - G

TECHNICAL CHARACTERISTICS	NORMA	INTERNATIONAL STANDARDS EN 14411 - G	AVERAGE VALUE							
<b>SIZE CHARACTERISTICS</b>										
<b>Sides</b>	EN ISO 10545-2	± 0,3% MAX (± 1,0 mm MAX)	COMPLYING							
<b>Thickness</b>	EN ISO 10545-2	± 5,0% MAX (± 0,5 mm MAX)	COMPLYING							
<b>Straightness of sides</b>	EN ISO 10545-2	± 0,3% MAX (± 0,8 mm MAX)	COMPLYING							
<b>Rectangularity</b>	EN ISO 10545-2	± 0,3% MAX (± 1,5 mm MAX)	COMPLYING							
<b>Surface flatness</b>	EN ISO 10545-2	± 0,4% MAX (± 1,8 mm MAX)	-							
<b>Water absorption</b>	EN ISO 10545-3	≤ 0,5%	≤ 0,05%							
<b>Flexion resistance</b>	EN ISO 10545-4	S ≥ 700 N (< 75 mm) S ≥ 1300 N (> 75 mm) R ≥ 35 N/mm <sup>2</sup>	6 mm S ≥ 900 N R ≥ 40 N/mm <sup>2</sup>	12 mm S ≥ 3500 N R ≥ 40 N/mm <sup>2</sup>	20 mm S ≥ 10000 N R ≥ 40 N/mm <sup>2</sup>					
<b>Impact resistance</b>	EN ISO 10545-5	DECLARED VALUE	> 0,85							
<b>Abrasion resistance</b>	EN ISO 10545-6	≤ 175 mm <sup>3</sup>	< 145 mm <sup>3</sup>							
<b>Coefficient of linear thermal-expansion</b>	EN ISO 10545-8	-	> 6x10 <sup>-6</sup> °C <sup>-1</sup>							
<b>Resistance to thermal shocks</b>	EN ISO 10545-9	PASS ACCORDING EN ISO 10545-1	NO DAMAGE							
<b>Frost resistance</b>	EN ISO 10545-12	PASS ACCORDING EN ISO 10545-1	NO DAMAGE							
<b>Resistance to chemicals</b>	EN ISO 10545-13	UB MIN.	MATTE A LA HA	SATIN A LA HA	POLISHED A LC HC					
<b>Resistance to stains</b>	EN ISO 10545-14	DECLARED VALUE	5							
<b>Lead and cadmium discharge</b>	EN ISO 10545-15	DECLARED VALUE	< THAN INSTRUMENT LIMIT							
<b>Skid resistance</b>	DIN 51130	-	MATTE R9	SAT* -	POL* -	PAT* R9	LEV* -	GLAM -		
			MATTE R10	6mm	GB 02 - GB03 - GB021 - GB22 - GB23 - GB24 - GB25 - GB26					
			MATTE R10	12mm	GB021 - GB22 - GB23 - GB24 - GB25 - GB26					

\*: SAT= SATIN - POL= POLISHED - PAT= PATINATED - LEV= LEVIGATO PEARL

**i** For specific certificates, please contact Infinity.

## 19.1 identification

### Product identifier

Trade name: PORCELAIN SLABS manufactured by Infinity - Divisione di Mirage Granito Ceramico S.p.A.

### Other means of identification

#### ■ Application of the substance/the mixture

Porcelain slabs for floors and walls

Porcelain slabs are made from a blend of high-quality clays, silica sand, feldspar and other naturally occurring minerals, combined with water and fired at high temperatures in a kiln. The resulting slabs are odorless and stable, non-flammable. Additionally, porcelain slabs are an environmentally friendly option compared to other flooring and wall covering materials, offering a more sustainable choice for construction projects. This product is specifically designed for both construction and decorative applications, making it ideal for a variety of indoor and outdoor settings. Typical uses include floors, walls, kitchen and bathroom countertops, and similar installations

### Details of the supplier of the safety data sheet

#### ■ Manufacturer/Supplier:

Infinity - Divisione di Mirage Granito Ceramico S.p.A.  
via Bottegone, n.83, 41026- Pavullo nel Frignano (MO) - Italy  
Reference number: +39 0536 329311

#### ■ Uses advised against

Do not mechanically process the material using dry methods. Always use wet methods (apply water) during all fabrication and processing. Avoid generating airborne dust, especially without appropriate respiratory protective equipment, adequate air filtration and adequate air ventilation systems which depend on the specific workplace conditions. Improper mechanical processing of this product may result in exposure to harmful silica dust (SiO<sub>2</sub>) inhalation, particularly if the recommended use of water, air filtration, and ventilation systems is not followed.

#### ■ Information department:

Infinity - Divisione di Mirage Granito Ceramico S.p.A.  
E-mail: info@infinitysurfaces.it

#### ■ Emergency telephone number: Infinity +39 0536 329311

## 19.2 hazard(s) identification

### Classification of the substance or mixture

- There is no proof or indication that the whole, finished product [definable as an "article" according to both 29 CFR 1910.1200 (Hazard Communication Standard)] has any risks according to Globally Harmonized System (GHS).

In the case of the breakage of the article or its processing, involving cutting, shaping, engraving or any other process which could lead to the release of dust traceable to the matrix of the article, it may generate crystalline silica powder (SiO<sub>2</sub>) in the form of quartz. Generation and inhalation of this dust shall be avoided.

The hazard assessment refers to this specific case.

No acute or chronic effects are known from exposure to intact slabs.

Please see Section 3 for the crystalline silica content of the whole finished product.

### Additional information:

The breathable fraction of crystalline silica (SiO<sub>2</sub>) may lead to lung damage or illnesses, such as silicosis.

- Eye irritation 2A
- Carcinogenicity 1A
- Specific target organ toxicity (single exposure) 3
- Specific target organ toxicity (repeated exposure) 1
- H319 Causes serious eye irritation.
- H350 May cause cancer.
- H335 May cause respiratory irritation.
- H372 Causes damage to the lung through prolonged or repeated exposure. Route of exposure: inhalation.

## 19.2 hazard(s) identification

### Label elements

#### ■ GHS label elements

Not applicable to intact slabs.



**WARNING:** This product can expose you to chemicals including crystalline silica which is known to the State of California to cause cancer.  
For more information go to [www.P65warnings.ca.gov](http://www.P65warnings.ca.gov).

#### ■ CAUTION: SILICA DUST HARMFUL IF INHALED.

Exposure to silica dust from cutting, grinding, or polishing can cause acute lung injury, silicosis, or cancer.  
Wear a respirator when cutting, grinding, or polishing.  
Use wet cutting methods and do not dry cut. Ensure adequate ventilation to minimize dust accumulation and exposure.  
Children should not be present during cutting, grinding, or polishing

### Other hazards

If the product is processed in such a way that significant particulates and/or dusts may be generated, exposure may aggravate pre-existing eye, skin, or respiratory conditions. Machines and tools with water supply systems or the "wet method" must be used. Do not mechanically process the material using dry methods. Avoid generating airborne dust, especially without appropriate respiratory protective equipment, adequate air filtration and adequate air ventilation systems. Improper mechanical processing of this product may result in exposure to harmful silica dust (SiO<sub>2</sub>) inhalation, particularly if the recommended use of water, air filtration, and ventilation systems is not followed.

### Hazard pictograms



GHS07



GHS08

### Signal word Danger

#### ■ Hazard-determining components of labeling:

Quartz (SiO<sub>2</sub>)  
Feldspar

#### ■ Hazard statements

Causes serious eye irritation.  
May cause cancer.  
May cause respiratory irritation.  
Causes damage to the lung through prolonged or repeated exposure. Route of exposure: inhalation.

#### ■ Precautionary statements

P201 Obtain special instructions before use.  
P260 Do not breathe dust.  
P280 Wear protective gloves/protective clothing/eye protection/face protection.

When exposed to high temperatures, free quartz can change crystal structure to form tridymite (above 870°C.) or cristobalite (above 1470°C.) which have greater health hazards than quartz due to their more fibrogenic characteristics. Manufacturers who crush, grind or cut ceramic bodies fired to high temperatures should recognize the possible presence of tridymite and/or cristobalite.

Slabs and boxes, if not grasped or handled correctly, can accidentally fall causing crushing of both hands and feet.

### Results of PBT and vPvB assessment

- PBT: Not applicable.
- vPvB: Not applicable.

## 19.3 composition/information on ingredients

### Chemical characterization: Mixtures

#### ■ Description:

Composition (%): The material is the result of high temperature sintering (between 1150 - 1250 °G) of various heavily compacted minerals in different proportions depending on the product.

Before sintering, the substances in the mixture are:

COMPONENTS		
CAS: 68476-25-5	Feldspar	30-50%
CAS: 1332-58-7	Kaolin	25-50%
CAS: 14808-60-7	Quartz (SiO <sub>2</sub> )	10-30%
CAS: 14807-96-6	Talc (Mg <sub>3</sub> H <sub>2</sub> (SiO <sub>3</sub> ) <sub>4</sub> )	0-6%

### Additional information:

After firing, the finished product includes mainly silica/quartz (5-30%), glass (50-70%), mullite (0-15%), feldspar (0-15%), small amounts of inorganic additives, as well as inorganic pigments.

## 19.4 first-aid measures

### Description of first aid measures

#### ■ General information:

First Aid Measures are applicable only to the dust resulting from crushing, grinding or sawing of slabs. Intact slabs pose no eye or inhalation hazards.

#### ■ After inhalation:

Supply fresh air. If required, provide artificial respiration. Keep patient warm. Consult doctor if symptoms persist. In case of unconsciousness place patient stably in side position for transportation.

### Most important symptoms and effects, both acute and delayed

No acute effects are known from exposure to intact slabs. Working with broken or cut slab produces a potential for cuts to the hands and exposed body parts. Acute effects such as eye irritation may occur if associated with high dust operations such as dry cutting or drilling the slab or during the removal of slab surfaces. Symptoms of acute silicosis, a form of silicosis (a nodular pulmonary fibrosis) associated with exposure to respirable crystalline silica, may develop following acute exposure to extremely dusty environments caused by generation of slab dust. Signs such as labored breathing and early fatigue may indicate silicosis; however, these same symptoms can arise from many other causes.

### Indication of any immediate medical attention and special treatment needed

No further relevant information available.

#### ■ After skin contact:

If skin irritation continues, consult a doctor.

#### ■ After eye contact:

Rinse opened eye for several minutes under running water. If symptoms persist, consult a doctor.

#### ■ After swallowing:

Rinse out mouth with water. Do not induce vomiting.

No chronic effects are known from exposure to intact slabs. Long-term, continual exposure to respirable crystalline silica at or above allowable occupational exposure limits may lead to the development of silicosis, a nodular pulmonary fibrosis (NPF). NPFs are also associated with pulmonary tuberculosis, bronchitis, emphysema, and other airway diseases. This type of chronic exposure to silica dust may also result in the development of autoimmune disorders, chronic renal disease, and other adverse health effects. Recent epidemiologic studies demonstrate that workers exposed to elevated silica concentrations have a significant risk of developing chronic silicosis. Signs such as labored breathing and early fatigue may indicate silicosis.

## 19.5 fire-fighting measures

### Extinguishing media

#### ■ Suitable extinguishing agents:

Use fire fighting measures that suit the environment. CO<sub>2</sub>, extinguishing powder or water spray. Fight larger fires with water spray or alcohol resistant foam.

#### ■ Special hazards arising from the substance or mixture

No further relevant information available.

### Additional information

Dispose of fire debris and contaminated fire fighting water in accordance with official regulations.

### Advice for firefighters

- **Protective equipment:** No special measures required.

## 19.6 accidental release measures

### ■ Personal precautions, protective equipment and emergency procedures

Avoid creating dust wherever possible.

### ■ Environmental precautions:

Clean up and collect spilled material. Avoid breathing particulates. If particulates are involved, evacuate the area of unprotected personnel during cleanup and wear an appropriate respirator.

### ■ Methods and material for containment and cleaning up:

Use wet sweeping compound or water to minimize particulates. Pick up mechanically.

## 19.7 handling and storage

### Precautions for safe handling

When cutting, grinding or removing, use wet cutting methods to reduce generation of dust. Wear suitable respiratory protective equipment. Please refer to OSHA 29 CFR 1910.1053 and 29 CFR 1926.1153 to determine whether respirators are necessary based on silica exposure levels. Then, consult 29 CFR 1910.134 for specific respiratory protection requirements, including respirator selection, fit testing, and maintenance. Additionally, ensure the use of appropriate respiratory protection even when using water as a dust reduction measure during product processing. Slabs and boxes, if not grasped or handled correctly, can accidentally fall causing crushing of both hands and feet.

### PROTECTIVE ACTION CRITERIA FOR CHEMICALS

<b>PAC-1:</b>		
CAS: 14808-60-7	Quartz (SiO <sub>2</sub> )	0.075 mg/m <sup>3</sup>
<b>PAC-2:</b>		
CAS: 14808-60-7	Quartz (SiO <sub>2</sub> )	8.3 mg/m <sup>3</sup>
<b>PAC-3:</b>		
CAS: 14808-60-7	Quartz (SiO <sub>2</sub> )	50 mg/m <sup>3</sup>

### ■ Reference to other sections

See Section 7 for information on safe handling.  
See Section 8 for information on personal protection equipment.  
See Section 13 for disposal information.

### ■ Information about protection against explosions and fires:

The product is not flammable.

### ■ Conditions for safe storage, including any incompatibilities

#### Storage:

**Requirements to be met by storerooms and receptacles:**  
Store in clean and dry conditions

**Information about storage in one common storage facility:**  
Do not store together with acids.

**Further information about storage conditions:** None.

- **Specific end use(s)** No further relevant information available.

## 19.8 exposure controls/personal protection

### Control parameters

#### Components with limit values that require monitoring at the workplace:

The following constituents are the only constituents of the product which have a **PEL**, **TLV** or other recommended exposure limit.

For the most up-to-date specific limits or limits for countries not listed here, please consult a qualified health and safety professional or the relevant regulatory authority in the respective country. The occupational exposure levels provided are for informational purposes only, are not legally binding, and may not be fully accurate.

	PEL	REL	TLV
<b>CAS: 1332-58-7 Kaolin</b>	Long-term value: 15* 5** mg/m3 *total dust **respirable fraction	Long-term value: 1 O* 5** mg/m3 *total dust **respirable fraction	Long-term value: 2* mg/m3 E; respirable particulate matter, A4
<b>CAS: 14808-60-7 Quartz (SiO<sub>2</sub>)</b>	Long-term value: 0.05* mg/m3 *resp. dust; 30mg/m3/%SiO <sub>2</sub> +2	Long-term value: 0.05* mg/m3 *respirable dust; See Pocket Guide App. A	Long-term value: 0.025* mg/m3 *respirable particulate matter, A2
<b>CAS: 14807-96-6 Talc (Mg<sub>3</sub>H<sub>2</sub> (SiO<sub>2</sub>)<sub>4</sub>)</b>	Long-term value: 20 mppcf ppm (containing <1% Quartz)	Long-term value: 2* mg/m3 *respirable dust; and <1% Quartz	Long-term value: 2* mg/m3

\*no asbestos fibers, resp. particulate matter, E, A4

### Regulatory information

- **PEL:** Guide to Occupational Exposure Values (OSHA PELs)
- **REL:** Guide to Occupational Exposure Values (NIOSH RELs)
- **TLV:** Guide to Occupational Exposure Values (TLV-ACGIH)

### Exposure controls

#### ■ Appropriate engineering controls

Always provide effective general and local exhaust ventilation to draw dust away from workers to prevent routine inhalation. Ventilation must be adequate to maintain the ambient workplace atmosphere below the permissible exposure limits.

### Additional information:

The lists that were valid during the creation were used as basis.

### Personal protective equipment:

#### ■ General protective and hygienic measures:

The usual precautionary measures for handling chemicals should be followed.  
Avoid creating airborne dust while working.  
Do not eat or drink while working.  
Wash hands before breaks and at the end of work.  
Keep away from tobacco products.  
Immediately remove all soiled and contaminated clothing.  
Always provide effective general and local exhaust ventilation to draw dust away from workers to prevent routine inhalation.  
Ventilation must be adequate to maintain the ambient workplace atmosphere below the permissible exposure limits.  
Avoid contact with the eyes and skin.

#### ■ Breathing equipment:



Wear full-face suitable respiratory protective equipment. Please refer to **OSHA 29 CFR 1910.1053** and **29 CFR 1926.1153** to determine whether respirators are necessary based on silica exposure levels. Then, consult **29 CFR 1910.134** for specific respiratory protection requirements, including respirator selection, fit testing, and maintenance. Additionally, ensure the use of appropriate respiratory protection even when using water as a dust reduction measure during product processing.

#### ■ Protection of hands:



Cotton or leather work gloves should be worn when cutting this product to minimize skin exposure to dust and/or cuts.

#### ■ Eye protection:



Use dust-proof goggles or safety glasses with side shields. Contact lenses may absorb irritants. Do not wear contact lenses in work areas.

#### ■ Body protection:

When processing the product wear work clothing made of a fabric that does not retain dust. Avoid cleaning with compressed air; use vacuum cleaning methods instead.

## 19.9 physical and chemical properties

### INFORMATION ON BASIC PHYSICAL AND CHEMICAL PROPERTIES

<b>General information</b>	
<b>Physical state</b>	solid
<b>Color</b>	different according to coloring
<b>Odor</b>	odorless
<b>Odor threshold</b>	not determined.
<b>Melting point/melting range</b>	undetermined.
<b>Boiling point/boiling range</b>	≥ 2200 °C (≥ 3,992 °F) (≥ 3992 °F)
<b>Flammability</b>	non-flammable mixture
<b>Explosion limits</b>	
<b>Lower</b>	not applicable.
<b>Upper</b>	not applicable.
<b>Flash point</b>	not applicable.
<b>Decomposition temperature</b>	not applicable.
<b>Ph-value</b>	not applicable. mixture is non-soluble (in water).
<b>Viscosity</b>	
<b>Kinematic</b>	not applicable.
<b>Dynamic</b>	not applicable.
<b>Solubility in/miscibility with water</b>	Insoluble.
<b>Partition coefficient (n-octanol/water)</b>	not applicable.
<b>Vapor pressure</b>	not applicable.
<b>density at 20 °C (68 °F)</b>	2.4-2.7 g/cm <sup>3</sup> (20.028-22.532 lbs/gal) (20.028-22.532 lbs/gal)
<b>vapor density</b>	Not applicable.
<b>particle characteristics</b>	Not determined.

### OTHER INFORMATION

<b>Appearance:</b>	
<b>Form:</b>	Solid
<b>Important information on protection of health and environment, and on safety.</b>	
<b>Ignition temperature:</b>	Product is not selfigniting.
<b>Danger of explosion:</b>	Product does not present an explosion hazard.
<b>Solvent content:</b>	
<b>VOC content:</b>	0,00%
<b>Change in condition</b>	
<b>Evaporation rate</b>	Not applicable.

## 19.10 stability and reactivity

- **Reactivity** No further relevant information available.
- **Chemical stability**  
**Thermal decomposition conditions to be avoided:**  
No decomposition if used and stored according to specifications.
- **Possibility of hazardous reactions**  
No dangerous reactions known.

- **Conditions to avoid** Protect from heat and direct sunlight.
- **Incompatible materials:**  
Keep away from: strong acids, strong bases and oxidation agents.
- **Hazardous decomposition products:**  
No dangerous decomposition products known.

## 19.11 toxicological information

- Information on toxicological effects Potential Health Effects: none for intact slab.

### Acute toxicity:

#### LD/LC50 VALUES THAT ARE RELEVANT FOR CLASSIFICATION:

##### CAS: 14808-60-7 QUARTZ (SiO<sub>2</sub>)

Oral	LD50	> 2,000 mg/kg (rat)
Dermal	LD50	> 2,000 mg/kg (rabbit)
Inhalative	LC50/4h	No specific data are available on acute toxicity that would permit a 100% categorical decision on the classification for acute toxicity by inhalation for any kind of crystalline silica. As a result, animal welfare concerns make further experiments unjustifiable.

### Primary irritant effect:

Symptoms/injuries After Inhalation: for particulates or dust from processing: irritation of the respiratory tract and the other mucous membranes. Cough, dyspnea (breathing difficulty), wheezing; decreased pulmonary function, progressive respiratory symptoms (silicosis). The lungs become very inflamed and may fill with fluid, causing severe shortness of breath and low blood oxygen levels.

### Carcinogenicity

Respirable Crystalline Silica (RCS)  
Respirable crystalline silica is classified by the International Agency for Research on Cancer (IARC) as a Group 1 Carcinogen (carcinogenic to humans). The National Toxicology Program lists respirable crystalline silica as "Known to be a Human Carcinogen". USDOL/OSHA and NIOSH regulated crystalline silica as carcinogenic.

### on the skin:

Symptoms/injuries After Skin Contact: for particulates or dust from processing: prolonged exposure may cause skin irritation. Direct contact may cause irritation by mechanical abrasion.

### on the eye:

Symptoms/injuries After Eye Contact: for particulates or dust from processing: may cause slight irritation to eyes. Contact may cause irritation due to mechanical abrasion.

### Additional toxicological information:

Exposure to respirable crystalline quartz may cause delayed (chronic) lung injury - silicosis. Acute or rapidly developing silicosis may occur in a short period of time in heavy exposure. Silicosis is a form of disabling pulmonary fibrosis which can be progressive and may lead to death. Some studies show that exposure to respirable crystalline silica (without silicosis) or that the disease silicosis may be associated with the increased incidence of several autoimmune disorders such as scleroderma (thickening of the skin), systemic lupus erythematosus, rheumatoid arthritis and diseases affecting the kidneys. Silicosis increases the risk of tuberculosis. Some studies show an increased incidence of chronic kidney disease and end-stage renal disease in workers exposed to respirable crystalline silica.

### Carcinogenic categories

#### IARC (INTERNATIONAL AGENCY FOR RESEARCH ON CANCER)

CAS: 14808-60-7	Quartz (SiO <sub>2</sub> )	1
CAS: 14807-96-6	Talc (Mg <sub>3</sub> H <sub>2</sub> (SiO <sub>2</sub> ) <sub>4</sub> )	2A

#### NTP (NATIONAL TOXICOLOGY PROGRAM)

CAS: 14808-60-7	Quartz (SiO <sub>2</sub> )	K
-----------------	----------------------------	---

#### OSHA-Ca (OCCUPATIONAL SAFETY & HEALTH ADMINISTRATION)

None of the ingredients is listed.

## 19.12 ecological information

### Toxicity

Aquatic toxicity: No further relevant information available.

### Persistence and degradability

No further relevant information available.

### Bioaccumulative potential

No further relevant information available.

### Mobility in soil

No further relevant information available.

### Results of PST and vPvB assessment

PST: Not applicable.

vPvB: Not applicable.

### Other adverse effects

#### Additional ecological information:

##### General notes:

Water hazard class 1 (Self-assessment): slightly hazardous for water.

Do not allow undiluted product or large quantities of it to reach ground water, water course or sewage system.

## 19.13 disposal considerations

### Waste treatment methods

#### Recommendation:

Disposal must be made according to official regulations.

### Uncleaned packagings:

#### Recommendation:

Disposal must be made according to official regulations

## 19.14 transport information

UN-Number DOT, ADR/RID/ADN, IMDG, IATA	Void
UN proper shipping name DOT, ADR/RID/ADN, IMDG, IATA	Void
Transport hazard class(es) DOT, ADR/RID/ADN, IMDG, IATA Class	Void
Packing group DOT, ADR/RID/ADN, IMDG, IATA	Void
Environmental hazards:	Not applicable.
Transport in bulk according to Annex II of MARPOL73/78 and the IBC Code	Not applicable.
Transport/Additional information:	Not dangerous according to the above specifications.
Special precautions for user	Not applicable.
UN "Model Regulation":	Void