

Stern Bracket Bolt Set 1/4" Upper Bolt Only

Compatible with the following:

Power-Pole 6' 2008 & Earlier

Power-Pole Sportsman Series 6' 2009 & 2010

Hardware

A. Qty (1) 1/4" x 3.5" Stern Bracket Bolt

B. Qty (2) 1/4" washers

C. Qty (4) small white bushings

D. Qty (1) long white bushing

E. Qty (2) short white bushings

F. Qty (1) 1/4" Low-profile mounting nut.

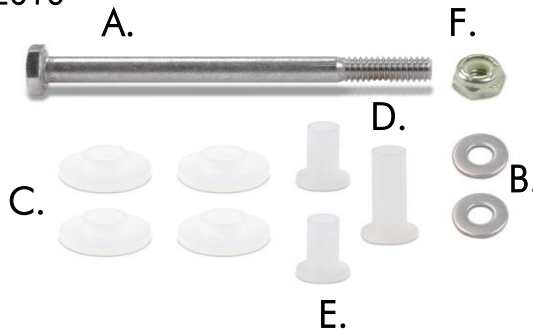

Installation Tools

- 7/16" Socket with Ratchet
- 7/16" Wrench
- Pliers

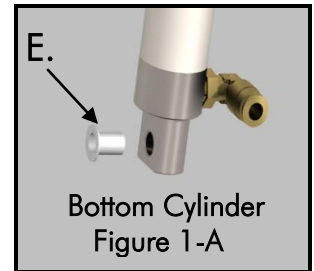

Left View of Stern Bracket
Figure 2-A

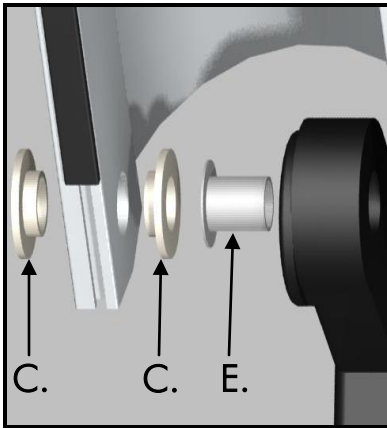

Stern Bracket
Figure 3-A

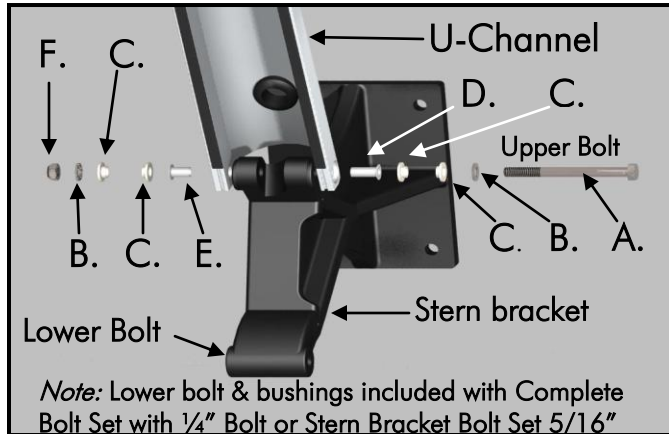

Right View of Stern Bracket
Figure 4-A

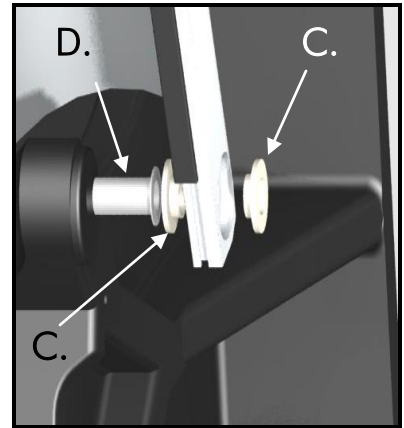

Installation Instructions:

Step 1 Remove old 1/4" bolt, bushings and remove hydraulic cylinder from stern bracket only. Note: you do not need to disconnect hydraulic lines from hydraulic cylinder.

Step 2 Remove old bushing E from bottom of cylinder and replace with new bushing E Figure 1-A.

Step 3 Insert bushings E and D into stern brackets Figures 2-A and Figure 4-A.

Step 4 Insert white bushings C into the insides of u-channel with small flange facing towards hole Figures 2-A and 4-A.

Step 5 Put washer B onto bolt A. Next put small white bushing C onto bolt A with flat side facing towards washer B.

Step 6 Install u-channel onto stern bracket Figure 3-A with bushing touching and aligning each hole.

Step 7 Insert the dressed bolt A through the u-channel, stern bracket, and hydraulic cylinder.

Step 8 Put small white bushing C onto bolt A with small flange facing towards u-channel hole followed by washer B.

Step 9 Finish by threading nut F on and tighten to 72 inch pounds / 6 foot pounds of torque upper and lower bolt.

For technical support please call 813-689-9932 opt 2.

