



PRAIRIE 360
KVF 360

All Terrain Vehicle Service Manual

All rights reserved. No parts of this publication may be reproduced, stored in a retrieval system, or transmitted in any form or by any means, electronic mechanical photocopying, recording or otherwise, without the prior written permission of Quality Assurance Department/Consumer Products & Machinery Company/Kawasaki Heavy Industries, Ltd., Japan.

No liability can be accepted for any inaccuracies or omissions in this publication, although every possible care has been taken to make it as complete and accurate as possible.

The right is reserved to make changes at any time without prior notice and without incurring an obligation to make such changes to products manufactured previously. See your dealer for the latest information on product improvements incorporated after this publication.

All information contained in this publication is based on the latest product information available at the time of publication. Illustrations and photographs in this publication are intended for reference use only and may not depict actual model component parts.

LIST OF ABBREVIATIONS

A	ampere(s)	lb	pounds(s)
ABDC	after bottom dead center	m	meter(s)
AC	alternating current	min	minute(s)
ATDC	after top dead center	N	newton(s)
BBDC	before bottom dead center	Pa	pascal(s)
BDC	bottom dead center	PS	horsepower
BTDC	before top dead center	psi	pound(s) per square inch
°C	degree(s) Celcius	r	revolution
DC	direct current	rpm	revolution(s) per minute
F	farad(s)	TDC	top dead center
°F	degree(s) Fahrenheit	TIR	total indicator reading
ft	foot, feet	V	volt(s)
g	gram(s)	W	watt(s)
h	hour(s)	Ω	ohm(s)
L	liter(s)		

Read OWNER'S MANUAL before operating.

EMISSION CONTROL INFORMATION

To protect the environment in which we all live, Kawasaki has incorporated crankcase emission (1) and exhaust emission (2) control systems in compliance with applicable regulations of the California Air Resources Board.

1. Crankcase Emission Control System

A sealed-type crankcase emission control system is used to eliminate blow-by gases. The blow-by gases are led to the breather chamber through the crankcase. Then, it is led to the air cleaner.

Oil is separated from the gases while passing through the inside of the breather chamber from the crankcase, and then returned back to the bottom of crankcase.

2. Exhaust Emission Control System

The exhaust emission control system applied to this engine family is engine modifications that consist of a modified carburetor and an ignition system having optimum ignition timing characteristics.

The carburetor has been calibrated to provide lean air/fuel mixture characteristics and optimum fuel economy with a suitable air cleaner and exhaust system.

A maintenance free ignition system provides the most favorable ignition timing and helps maintain a thorough combustion process within the engine which contributes to a reduction of exhaust pollutants entering the atmosphere.

The Clean Air Act, which is the Federal law covering motor vehicle pollution, contains what is commonly referred to as the Act's "tampering provisions."

"Sec. 203(a) The following acts and the causing thereof are prohibited...

(3)(A) for any person to remove or render inoperative any device or element of design installed on or in a motor vehicle or motor vehicle engine in compliance with regulations under this title prior to its sale and delivery to the ultimate purchaser, or for any manufacturer or dealer knowingly to remove or render inoperative any such device or element of design after such sale and delivery to the ultimate purchaser.

(3)(B) for any person engaged in the business of repairing, servicing, selling, leasing, or trading motor vehicles or motor vehicle engines, or who operates a fleet of motor vehicles knowingly to remove or render inoperative any device or element of design installed on or in a motor vehicle or motor vehicle engine in compliance with regulations under this title following its sale and delivery to the ultimate purchaser..."

NOTE

○ *The phrase "remove or render inoperative any device or element of design" has been generally interpreted as follows:*

1. Tampering does not include the temporary removal or rendering inoperative of devices or elements of design in order to perform maintenance.

2. Tampering could include:

a. Maladjustment of vehicle components such that the emission standards are exceeded.

b. Use of replacement parts or accessories which adversely affect the performance or durability of the vehicle.

c. Addition of components or accessories that result in the vehicle exceeding the standards.

d. Permanently removing, disconnecting, or rendering inoperative any component or element of design of the emission control systems.

WE RECOMMEND THAT ALL DEALERS OBSERVE THESE PROVISIONS OF FEDERAL LAW, THE VIOLATION OF WHICH IS PUNISHABLE BY CIVIL PENALTIES NOT EXCEEDING \$10,000 PER VIOLATION.

**PLEASE DO NOT TAMPER WITH NOISE CONTROL SYSTEM
(US MODEL only)**

To minimize the noise emissions from this product, Kawasaki has equipped it with effective intake and exhaust silencing systems. They are designed to give optimum performance while maintaining a low noise level. Please do not remove these systems, or alter them in any which results in an increase in noise level.

Foreword

This manual is designed primarily for use by trained mechanics in a properly equipped shop. However, it contains enough detail and basic information to make it useful to the owner who desires to perform his own basic maintenance and repair work. A basic knowledge of mechanics, the proper use of tools, and workshop procedures must be understood in order to carry out maintenance and repair satisfactorily. Whenever the owner has insufficient experience or doubts his ability to do the work, all adjustments, maintenance, and repair should be carried out only by qualified mechanics.

In order to perform the work efficiently and to avoid costly mistakes, read the text, thoroughly familiarize yourself with the procedures before starting work, and then do the work carefully in a clean area. Whenever special tools or equipment are specified, do not use makeshift tools or equipment. Precision measurements can only be made if the proper instruments are used, and the use of substitute tools may adversely affect safe operation.

For the duration of the warranty period, we recommend that all repairs and scheduled maintenance be performed in accordance with this service manual. Any owner maintenance or repair procedure not performed in accordance with this manual may void the warranty.

To get the longest life out of your vehicle:

- Follow the Periodic Maintenance Chart in the Service Manual.
- Be alert for problems and non-scheduled maintenance.
- Use proper tools and genuine Kawasaki Vehicle parts. Special tools, gauges, and testers that are necessary when servicing Kawasaki vehicles are introduced by the Special Tool Catalog or Manual. Genuine parts provided as spare parts are listed in the Parts Catalog.
- Follow the procedures in this manual carefully. Don't take shortcuts.
- Remember to keep complete records of maintenance and repair with dates and any new parts installed.

How to Use This Manual

In this manual, the product is divided into its major systems and these systems make up the manual's chapters. The Quick Reference Guide shows you all of the product's

system and assists in locating their chapters. Each chapter in turn has its own comprehensive Table of Contents.

For example, if you want ignition coil information, use the Quick Reference Guide to locate the Electrical System chapter. Then, use the Table of Contents on the first page of the chapter to find the Ignition Coil section.

Whenever you see these WARNING and CAUTION symbols, heed their instructions! Always follow safe operating and maintenance practices.

▲WARNING

This warning symbol identifies special instructions or procedures which, if not correctly followed, could result in personal injury, or loss of life.

CAUTION

This caution symbol identifies special instructions or procedures which, if not strictly observed, could result in damage to or destruction of equipment.

This manual contains four more symbols (in addition to WARNING and CAUTION) which will help you distinguish different types of information.

NOTE

- *This note symbol indicates points of particular interest for more efficient and convenient operation.*
- Indicates a procedural step or work to be done.
- Indicates a procedural sub-step or how to do the work of the procedural step it follows. It also precedes the text of a NOTE.
- ★ Indicates a conditional step or what action to take based on the results of the test or inspection in the procedural step or sub-step it follows.

In most chapters an exploded view illustration of the system components follows the Table of Contents. In these illustrations you will find the instructions indicating which parts require specified tightening torque, oil, grease or a locking agent during assembly.

General Information

Table of Contents

Before Servicing.....	1-2
Model Identification	1-4
General Specifications	1-6
Special Tools and Sealant.....	1-8
Unit Conversion Table.....	1-14

1-2 GENERAL INFORMATION

Before Servicing

Before starting to perform an inspection service or carry out a disassembly and reassembly operation on a vehicle, read the precautions given below. To facilitate actual operations, notes, illustrations, photographs, cautions, and detailed descriptions have been included in each chapter wherever necessary. This section explains the items that require particular attention during the removal and reinstallation or disassembly and reassembly of general parts.

Especially note the following:

- (1) Dirt
Before removal and disassembly, clean the vehicle. Any dirt entering the engine will shorten the life of the vehicle. For the same reason, before installing a new part, clean off any dust or metal filings.
- (2) Battery Ground
Disconnect the ground (–) wire from the battery before performing any disassembly operations on the vehicle. This prevents the engine from accidentally turning over while work is being carried out, sparks from being generated while disconnecting the wires from electrical parts, as well as damage to the electrical parts themselves. For reinstallation, first connect the positive wire to the positive (+) terminal of the battery
- (3) Installation, Assembly
Generally, installation or assembly is the reverse of removal or disassembly. However, if installation or assembly sequence is given in this Service Manual, follow it. Note parts locations and cable, wire, and hose routing during removal or disassembly so they can be installed or assembled in the same way. It is preferable to mark and record the locations and routing whenever possible.
- (4) Tightening Sequence
When installing bolts, nuts, or screws for which a tightening sequence is given in this Service Manual, make sure to follow the sequence. When installing a part with several bolts, nuts, or screws, start them all in their holes and tighten them to a snug fit, thus ensuring that the part has been installed in its proper location. Then, tighten them to the specified torque in the tightening sequence and method indicated. If tightening sequence instructions are not given, tighten them evenly in a cross pattern. Conversely, to remove a part, first loosen all the bolts, nuts, or screws that are retaining the part a 1/4–turn before removing them.
- (5) Torque
When torque values are given in this Service Manual, use them. Either too little or too much torque may lead to serious damage. Use a good quality, reliable torque wrench.
- (6) Force
Common sense should dictate how much force is necessary in assembly and disassembly. If a part seems especially difficult to remove or install, stop and examine what may be causing the problem. Whenever tapping is necessary, tap lightly using a wooden or plastic-faced mallet. Use an impact driver for screws (particularly for the removing screws held by non-permanent locking agent) in order to avoid damaging the screw heads.
- (7) Edges
Watch for sharp edges, as they could cause injury through careless handling, especially during major engine disassembly and assembly. Use a clean piece of thick cloth when lifting the engine or turning it over.
- (8) High-Flash Point Solvent
A high-flash point solvent is recommended to reduce fire danger. A commercial solvent commonly available in North America is standard solvent (generic name). Always follow manufacturer and container directions regarding the use of any solvent.
- (9) Gasket, O-Ring
Replace a gasket or an O-ring with a new part when disassembling. Remove any foreign matter from the mating surface of the gasket or O-ring to ensure a perfectly smooth surface to prevent oil or compression leaks.
- (10) Liquid Gasket, Locking Agent
Clean and prepare surfaces where liquid gasket or non-permanent locking agent will be used. Apply them sparingly. Excessive amount may block engine oil passages and cause serious damage.
- (11) Press
When using a press or driver to install a part such as a wheel bearing, apply a small amount of oil to the area where the two parts come in contact to ensure a smooth fit.
- (12) Ball Bearing and Needle Bearing
Do not remove a ball bearing or a needle bearing unless it is absolutely necessary. Replace any ball or needle bearings that were removed with new ones. Install bearings with the manufacturer and size marks facing out, applying pressure evenly with a suitable driver. Apply force only to the end of the race that contacts the press fit portion, and press it evenly over the base component.
- (13) Oil Seal and Grease Seal
Replace any oil or grease seals that were removed with new ones, as removal generally damages seals. Oil or grease seals should be pressed into place using a suitable driver, applying a force uniformly to the end of seal until the face of the seal is even with the end of the hole, unless instructed otherwise. When pressing in an oil or grease seal which has manufacturer's marks, press it in with the marks facing out.

Before Servicing

(14) Circlip, Retaining Ring, and Cotter Pin

When installing circlips and retaining rings, take care to compress or expand them only enough to install them and no more. Install the circlip with its chamfered side facing load side as well.

Replace any circlips, retaining rings, and cotter pins that were removed with new ones, as removal weakens and deforms them. If old ones are reused, they could become detached while the vehicle is driven, leading to a major problem.

(15) Lubrication

Engine wear is generally at its maximum while the engine is warming up and before all the sliding surfaces have an adequate lubricative film. During assembly, make sure to apply oil to any sliding surface or bearing that has been cleaned. Old grease or dirty oil could have lost its lubricative quality and may contain foreign particles that act as abrasives; therefore, make sure to wipe it off and apply fresh grease or oil. Some oils and greases in particular should be used only in certain applications and may be harmful if used in an application for which they are not intended.

(16) Direction of Engine Rotation

To rotate the crankshaft manually, make sure to do so in the direction of positive rotation. Positive rotation is counterclockwise as viewed from the left side of the engine. To carry out proper adjustment, it is furthermore necessary to rotate the engine in the direction of positive rotation as well.

(17) Replacement Parts

When there is a replacement instruction, replace these parts with new ones every time they are removed.

Replacement parts will be damaged or lose their original function once they are removed. Therefore, always replace these parts with new ones every time they are removed. Although the previously mentioned gasket, O-ring, ball bearing, needle bearing, grease seal, oil seal, circlip, and cotter pin have not been so designated in their respective text, they are replacement parts.

(18) Electrical Wires

All the electrical wires are either one-color or two-color. A two-color wire is identified first by the primary color and then the stripe color. For example, a yellow wire with thin red stripes is referred to as a "yellow/red" wire; it would be a "red/yellow" wire if the colors were reversed. Unless instructed otherwise, electrical wires must be connected to wires of the same color.

Two-Color Electrical

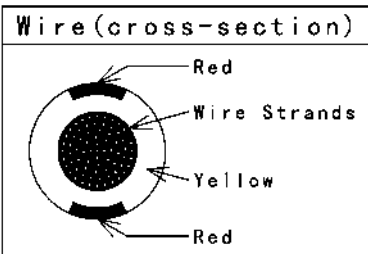
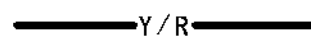
Wire (cross-section)	Color Indicated on the Wire	Color Indicated on the Wiring Diagram
	Yellow/Red	

GB020601W1 C

(19) Inspection

When parts have been disassembled, visually inspect these parts for the following conditions or other damage. If there is any doubt as to the condition of them, replace them with new ones.

Abrasion	Crack	Hardening	Warp
Bent	Dent	Scratch	Wear
Color change	Deterioration	Seizure	

(20) Specifications

Specification terms are defined as follows:

"Standards" show dimensions or performances which brand-new parts or systems have.

"Service Limits" indicate the usable limits. If the measurement shows excessive wear or deteriorated performance, replace the damaged parts.

1-4 GENERAL INFORMATION

Model Identification

KVF360-A1



HB03B004 P

Model Identification

KVF360-A1



HB03B005 P

1-6 GENERAL INFORMATION

General Specifications

Items	KVF360-A1
Dimensions: Overall length Overall width Overall height Wheelbase Ground clearance: Rear final gear case Center of frame Seat height Dry mass Curb mass: Front Rear Fuel tank capacity	2065 mm (81.30 in.) 1205 mm (47.44 in.) 1175 mm (46.26 in.) 1250 mm (49.21 in.) 195 mm (7.68 in.) 250 mm (9.84 in.) 890 mm (35.04 in.) 274 kg (604 lb), (US) 272.5 kg (601 lb) 154 kg (340 lb), (US) 153 kg (337 lb) 135 kg (298 lb), (US) 134 kg (295 lb) 13.5 L (3.6 US gal)
Performance: Minimum turning radius	3.1 m (10.17 ft)
Engine: Type Cooling system Bore and stroke Displacement Compression ratio Maximum horsepower Maximum torque Carburetion system Starting system Ignition system Timing advance Ignition timing Spark plug Valve timing: Inlet Open Close Duration Exhaust: Open Close Duration Lubrication system Engine oil: Type Viscosity Capacity	4-stroke, SOHC, 1-cylinder Air-cooled 80.0 x 72.0 mm (3.15 x 2.83 in.) 362 mL (22.1 cu in.) 8.3 : 1 15.7 kW (21.4 PS) @7000 r/min (rpm), (US) - 26.1 N·m (2.66 kgf·m, 19.25 ft·lb) @4500 r/min (rpm) Carburetor, Keihin CVK34 Electric Starter & Recoil Starter DC-CDI Electronically advanced From 10° BTDC @1300 r/min (rpm) to 30° BTDC @5 000 r/min (rpm) NGK DPR8EA-9 38° BTDC 58° ABDC 276° 68° BBDC 28° ATDC 276° Forced lubrication (wet sump) API SF or SG API SH or SJ with JASO MA SAE 10W-40 2.3 L (2.17 US qt)
Drive Train: Primary reduction system: Type Reduction ratio	Belt converter 3.122 ~ 0.635

GENERAL INFORMATION 1-7

General Specifications

Items	KVF360-A1
Transmission: Type Gear ratios: Forward: High Low Reverse Final drive system: Type Reduction ratio Overall drive ratio: Forward: High Low Reverse Front final gear case oil: Type Viscosity Capacity Rear final gear case oil: Type Capacity	2-speed plus reverse 3.548 (30/26 x 29/18 x 21/11) 5.536 (36/20 x 29/18 x 21/11) 4.613 (16/12 x 18/16 x 29/18 x 21/11) Shaft, 2WD/4WD 4.375 (35/8) 48.474 ~ 9.859 75.619 ~ 15.380 63.016 ~ 12.817 API SF or SG API SH or SJ with JASO MA SAE 10W-40 0.43 L (0.45 US qt) MOBIL Fluid 424 or Kawa Chem Gear & Wet Brake Oil (CITGO TRANSGARD TRACTOR HYDRAULIC FLUID) 900 mL (0.95 US qt)
Frame: Type Caster (rake angle) Camber King pin angle Trail Tread: Front Rear Front tire: Type Size Rear tire: Type Size Suspension: Front: Type Wheel travel Rear: Type Wheel travel Brake: Front Rear	Double cradle, tubular steel 2.5° 0.5° 14.5° 15 mm (0.59 in.) 890 mm (35.04 in.) 895 mm (35.24 in.) Tubeless AT25 x 8 – 12 Tubeless AT25 x 10 – 12 MacPherson strut 170 mm (6.69 in.) Swingarm 180 mm (7.09 in.) Disc x 2 Enclosed wet multi-plate
Electrical Equipment: Battery Headlight: Type Bulb Tail/brake light Bulb Alternator: Type Rated output	12 V 14 Ah Semi-sealed beam 12 V 30/30 W x 2 12 V 5/18 W Three - phase AC 25 A, 14 V @8000 r/min (rpm)

Specifications are subject to change without notice, and may not apply to every country.

US: U.S.A. Model

1-8 GENERAL INFORMATION

Special Tools and Sealant

Bearing Puller : 57001-135

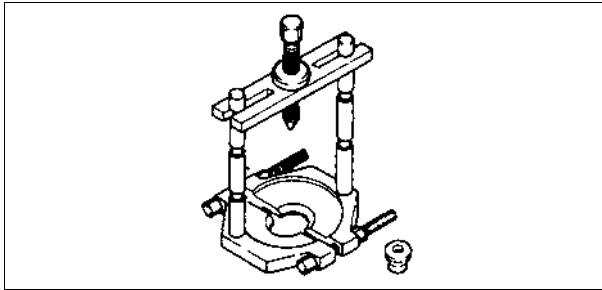

Valve Guide Arbor, $\phi 7$: 57001-163

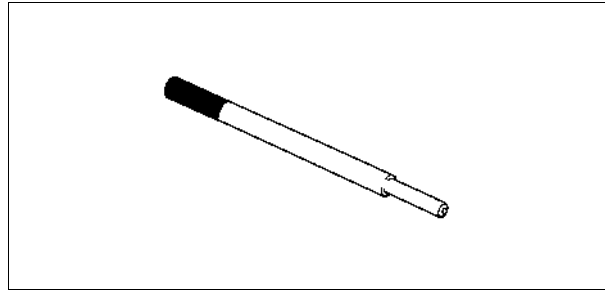

Inside Circlip Pliers : 57001-143

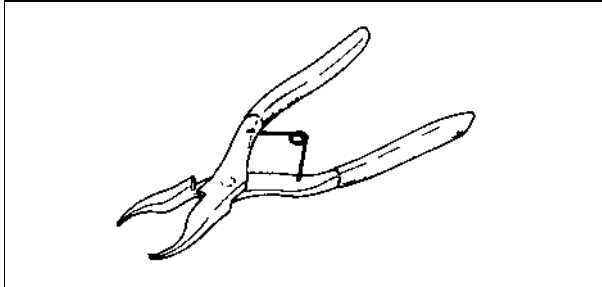

Oil Pressure Gauge, 10 kg/cm² : 57001-164

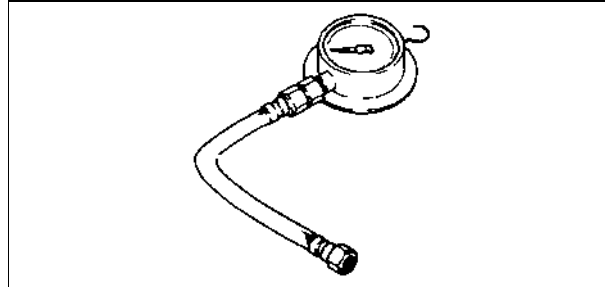

Outside Circlip Pliers : 57001-144

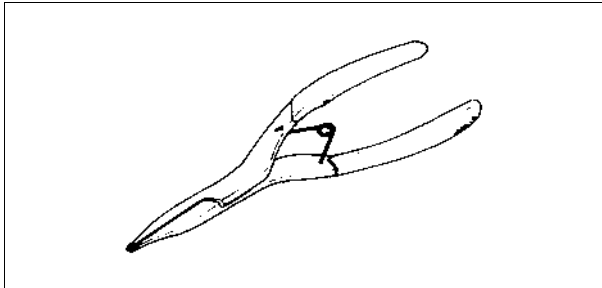

Compression Gauge : 57001-221



Circlip Pliers : 57001-154

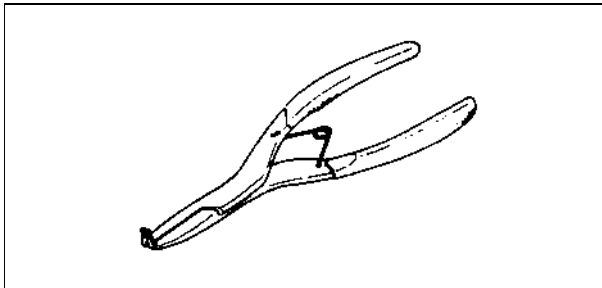

Valve Spring Compressor Assembly : 57001-241

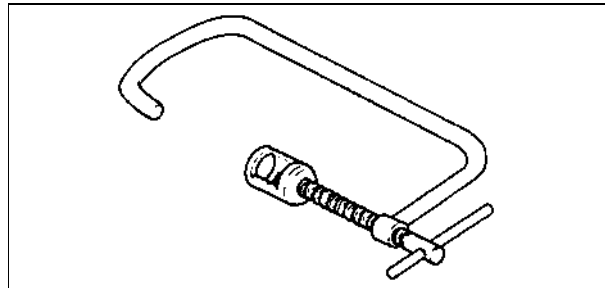

Valve Guide Reamer, $\phi 7$: 57001-162

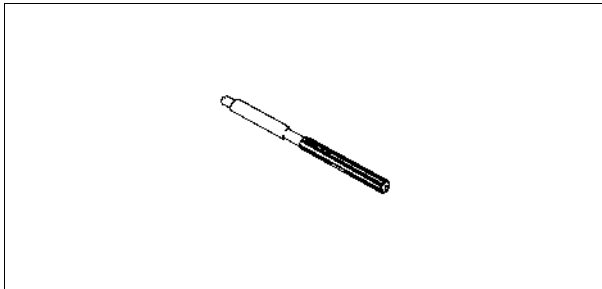

Valve Spring Compressor Adapter, $\phi 28.2$: 57001-243

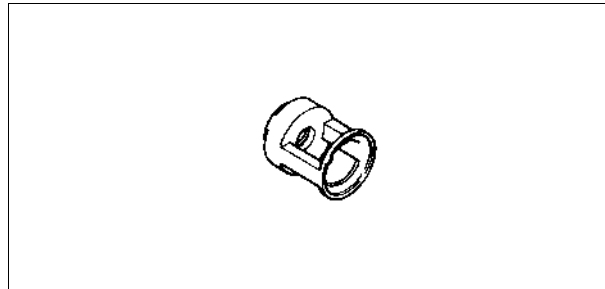

Special Tools and Sealant

Piston Pin Puller Assembly : 57001-910

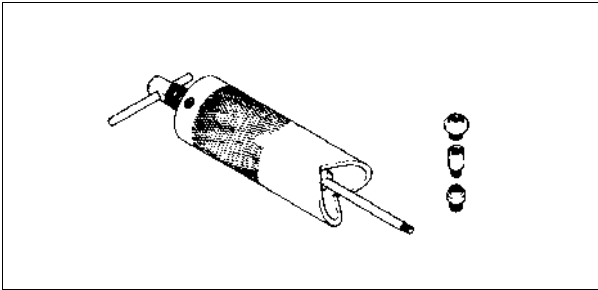

Steering Stem Nut Wrench : 57001-1100

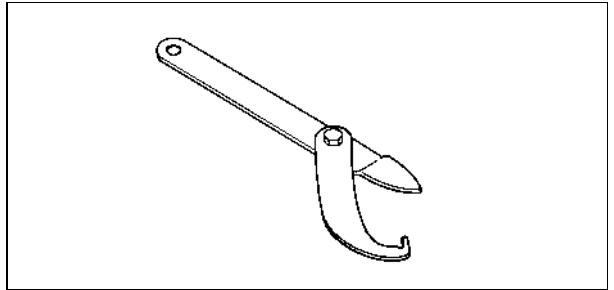

Fuel Level Gauge : 57001-1017

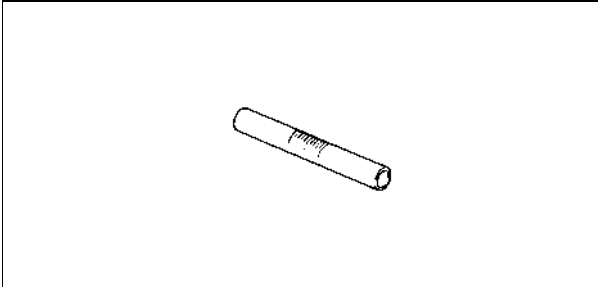

Valve Seat Cutter, 45° - ϕ 41.5 : 57001-1117

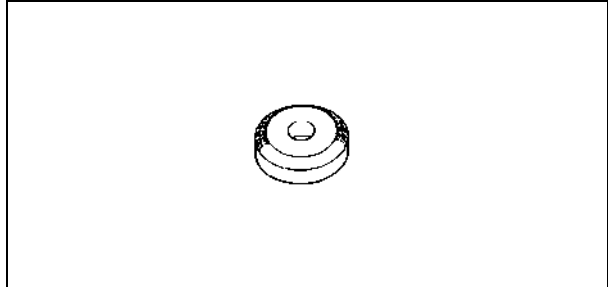

Compression Gauge Adapter, M12 x 1.25 : 57001-1018

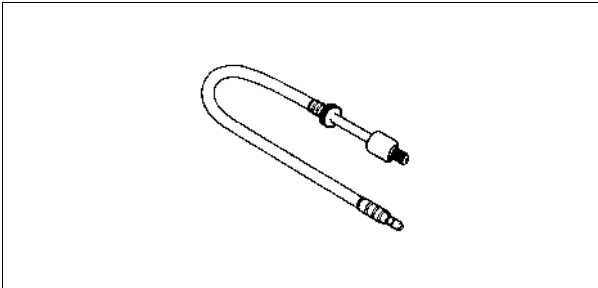

Valve Seat Cutter, 32° - ϕ 38.5 : 57001-1122

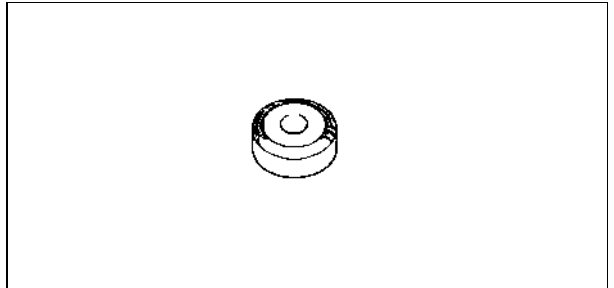

Oil Pressure Gauge Adapter, PT 1/8 : 57001-1033

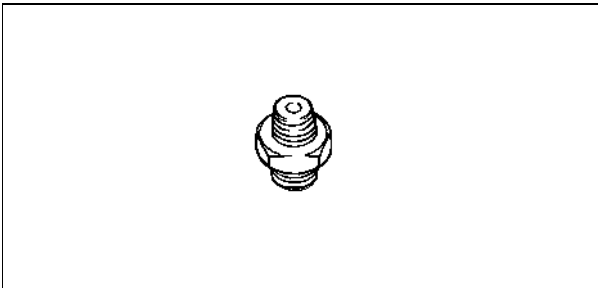

Valve Seat Cutter Holder Bar : 57001-1128

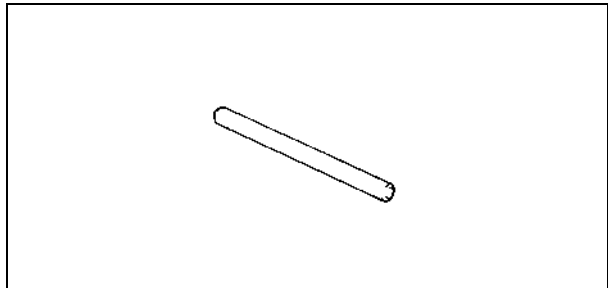

Oil Seal & Bearing Remover : 57001-1058

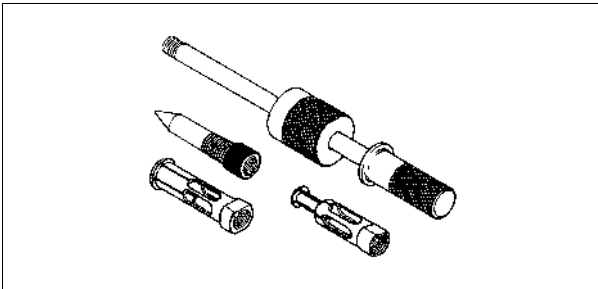

Bearing Driver Set : 57001-1129



1-10 GENERAL INFORMATION

Special Tools and Sealant

Piston Pin Puller Adapter : 57001-1211

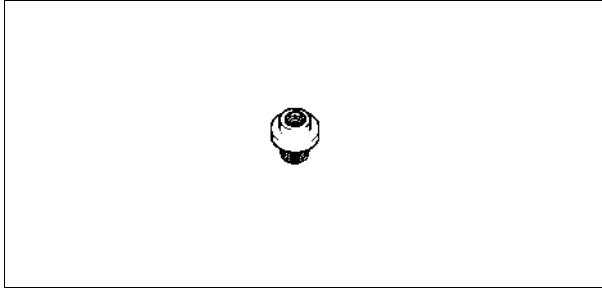

Carburetor Drain Plug Wrench, Hex 3 : 57001-1269

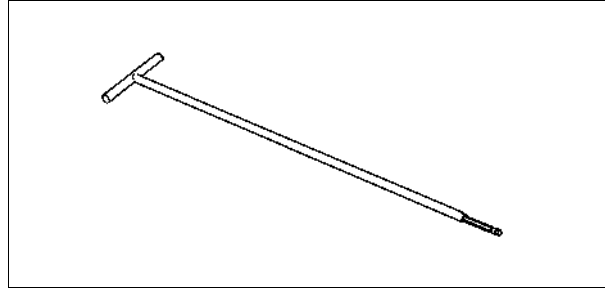

Jack : 57001-1238

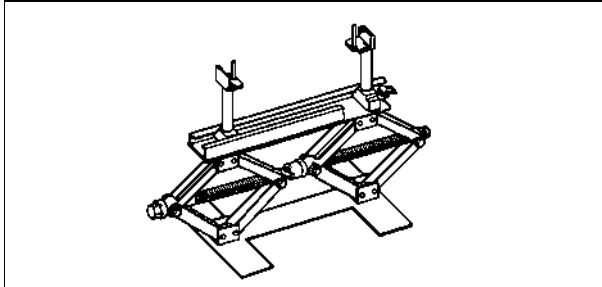

Flywheel & Pulley Holder : 57001-1343

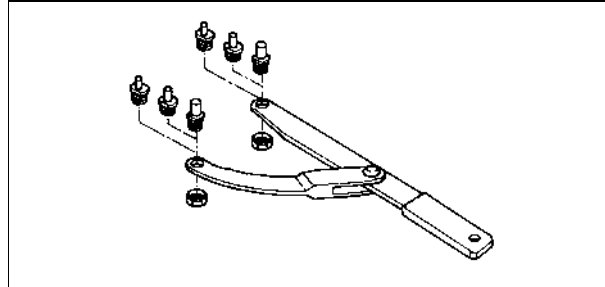

Pilot Screw Adjuster, A : 57001-1239

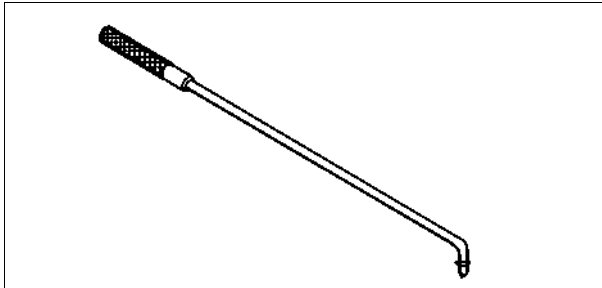

Socket Wrench : 57001-1363

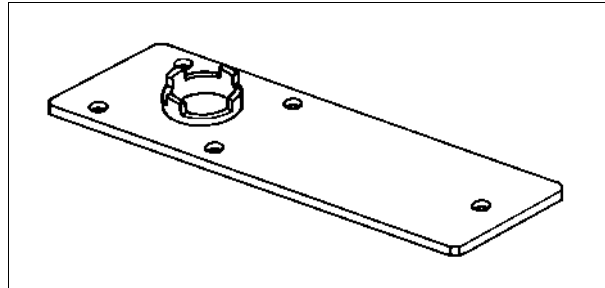

Timing Light : 57001-1241

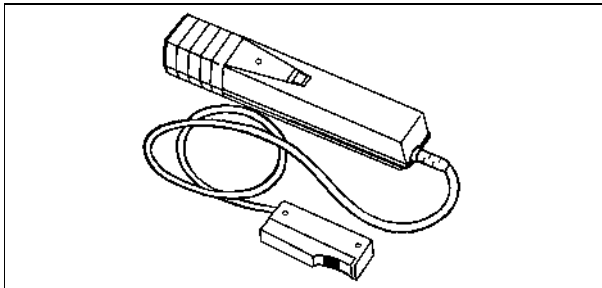

Hand Tester : 57001-1394

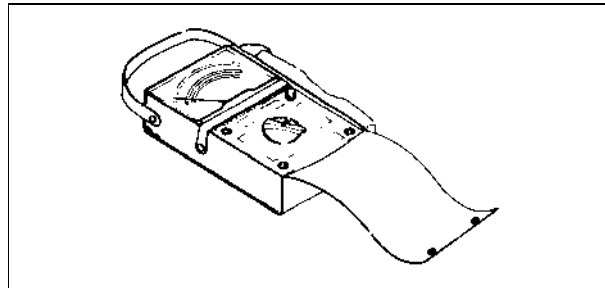

Oil Filter Wrench : 57001-1249

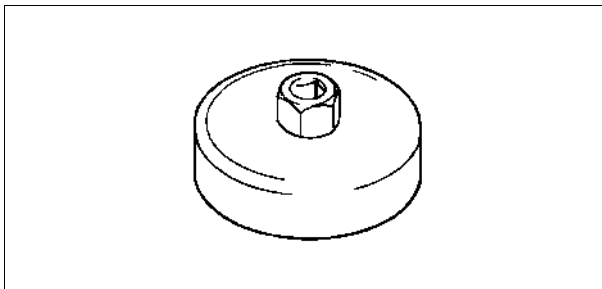

Flywheel Puller Assembly : 57001-1405

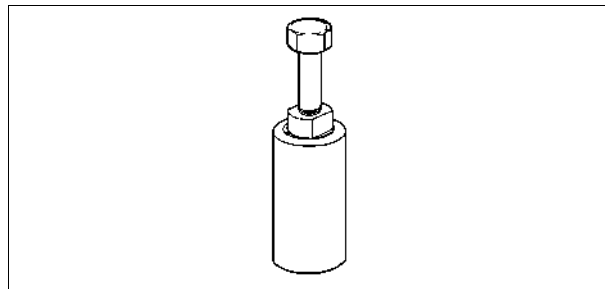

Special Tools and Sealant

Drive & Driven Pulley Holder : 57001-1412

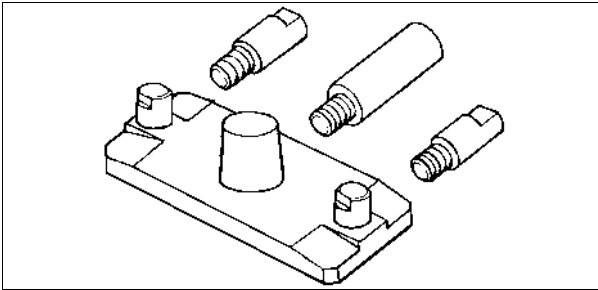

Drive Pulley Wrench : 57001-1474

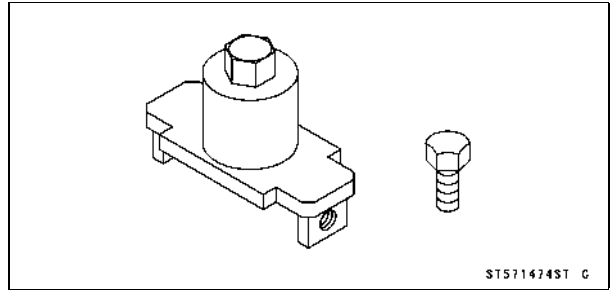

Drive Pulley Puller Bolt : 57001-1429

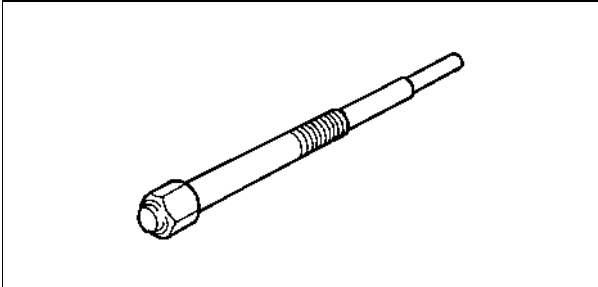

Damper Spring Compressor Set : 57001-1475

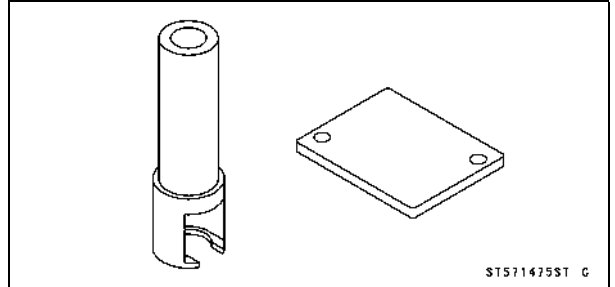

Filler Cap Driver : 57001-1454

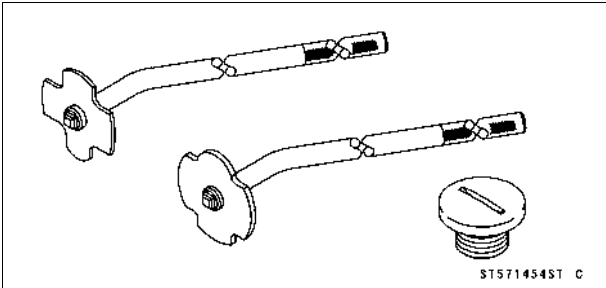

Holder & Guide Arbor : 57001-1476

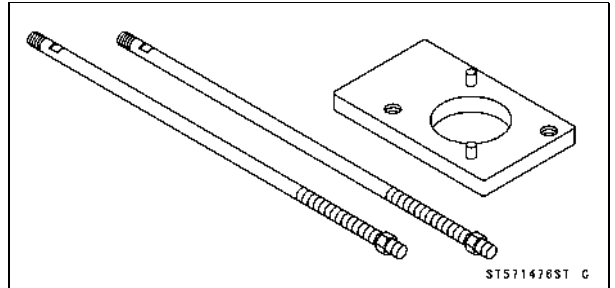

Pulley Holder Attachment : 57001-1472

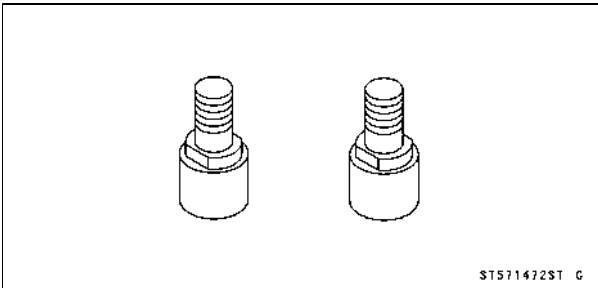

Spacer & Holder : 57001-1477

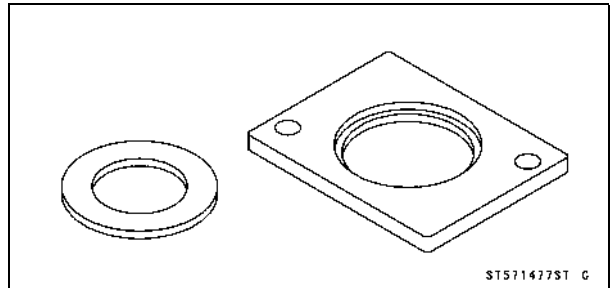

Drive & Driven Pulley Holder : 57001-1473

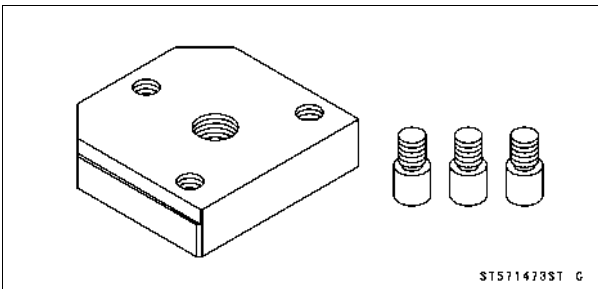

Socket Wrench, Hex 50 : 57001-1478

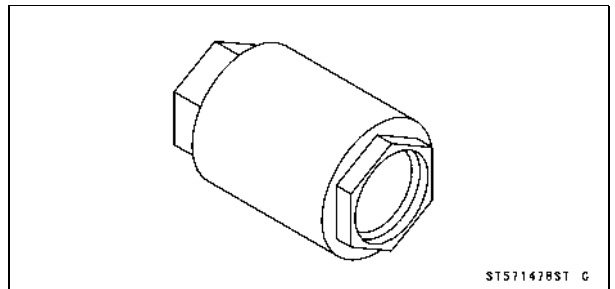

1-12 GENERAL INFORMATION

Special Tools and Sealant

Output Shaft Holder & Spacer : 57001-1479

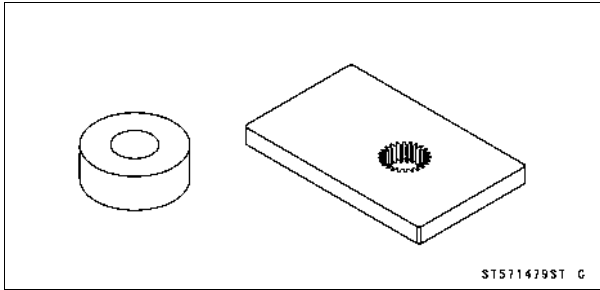

Socket Wrench, Hex 41 : 57001-1484

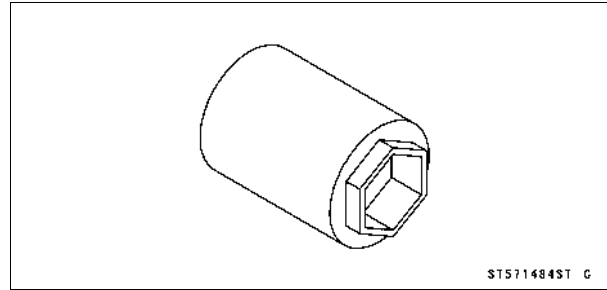

Pinion Gear Holder : 57001-1480

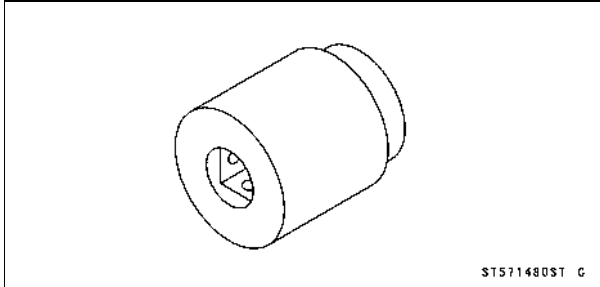

Pinion Gear Holder : 57001-1485

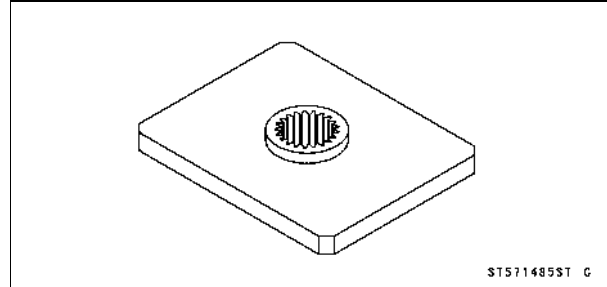

Nut Holding Bolts : 57001-1481

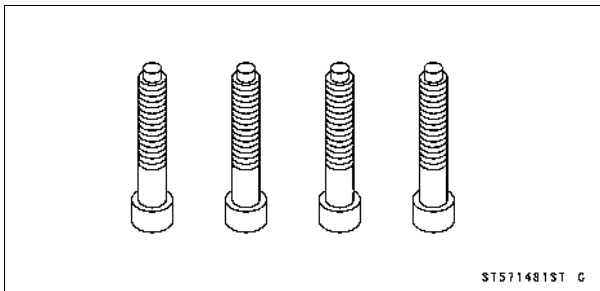

Oil Seal Driver: 57001-1487

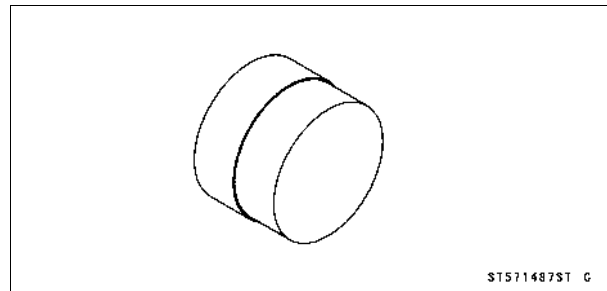

Socket Wench : 57001-1482

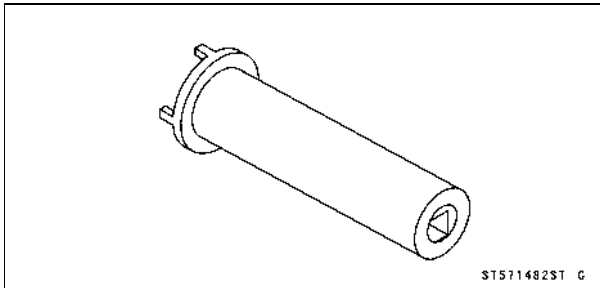

Gear Holder & Socket Wrench, Hex 24 : 57001-1489

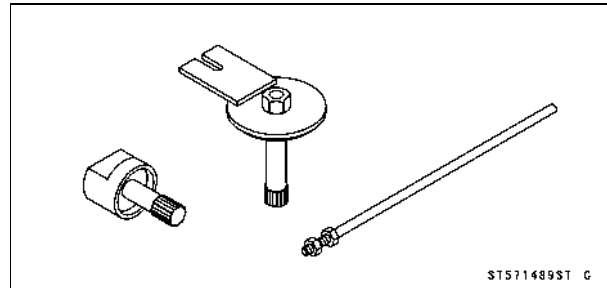

Spring Holder Set : 57001-1483

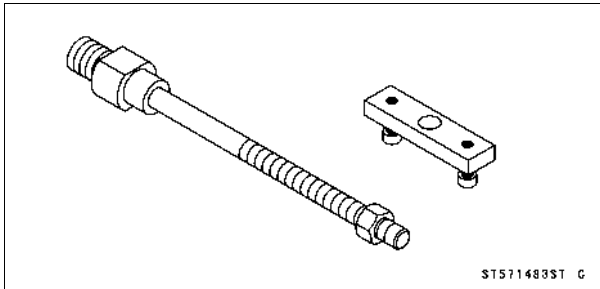

Hexagon Wench, Hex 41 : 57001-1491

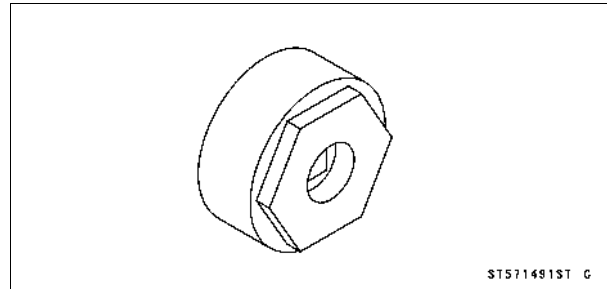

Special Tools and Sealant

Drive Pulley Measurement Tool : 57001-1498

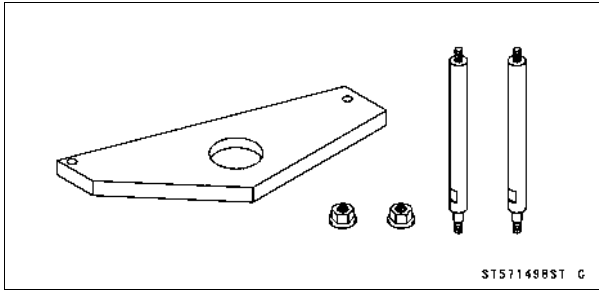

Valve Seat Cutter, 50°-φ44: 57001-1516

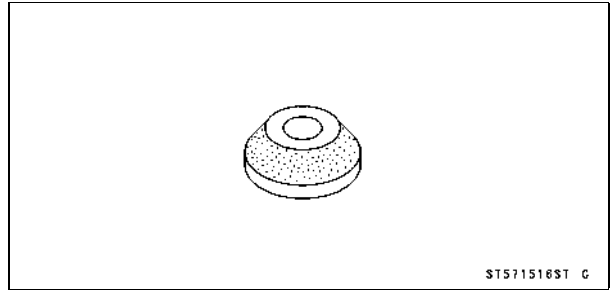

Actuator Lever Measurement Tool : 57001-1499

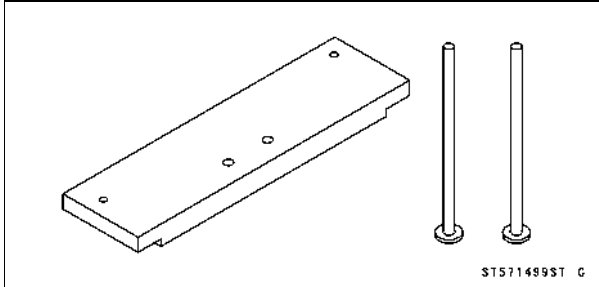

Oil Seal Driver: 57001-1517

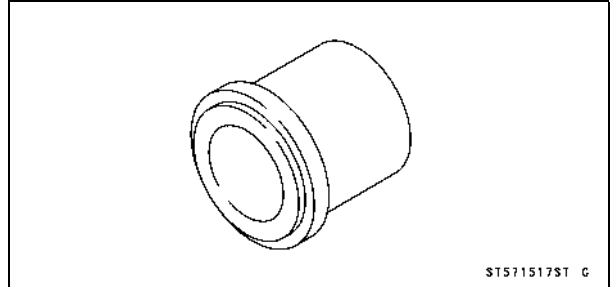

Oil Seal Driver, φ18: 57001-1505

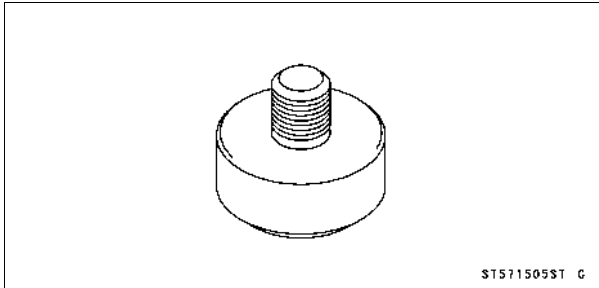

Belt Measuring Gauge: 57001-1519

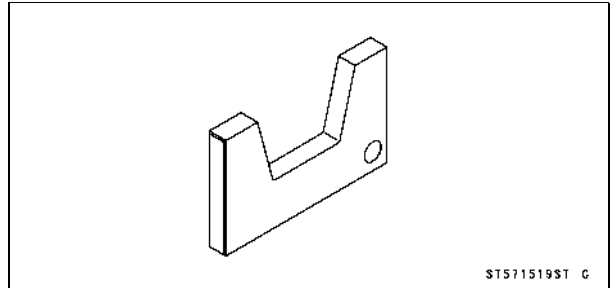

Oil Seal Driver, φ48: 57001-1506

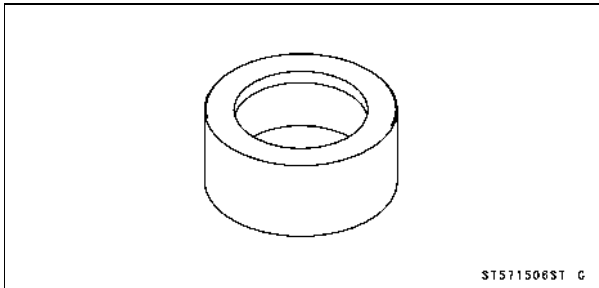

Drive Pulley Holder: 57001-1520

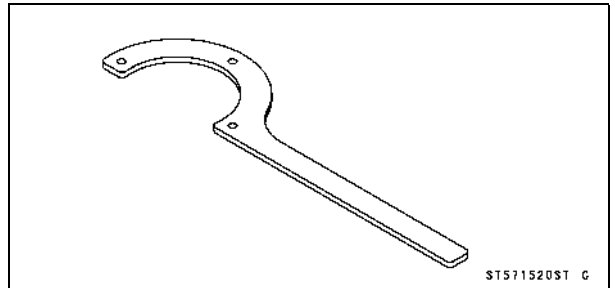

Valve Seat Cutter, 32°-φ44: 57001-1515

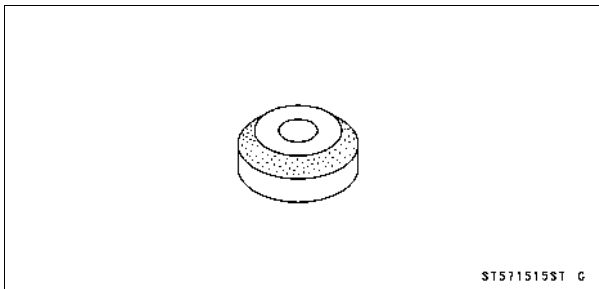

Kawasaki Bond (Silicone Sealant) : 56019-120

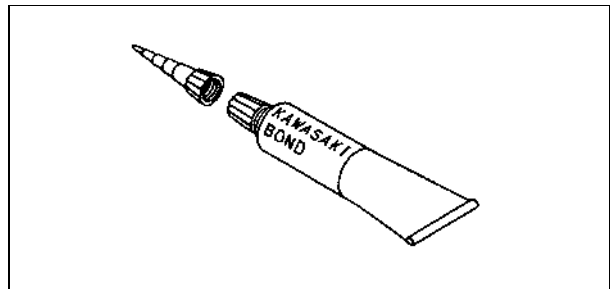

1-14 GENERAL INFORMATION

Unit Conversion Table

Prefixes for Units:

Prefix	Symbol	Power
mega	M	× 1 000 000
kilo	k	× 1 000
centi	c	× 0.01
milli	m	× 0.001
micro	μ	× 0.000001

Units of Mass:

kg	×	2.205	=	lb
g	×	0.03527	=	oz

Units of Volume:

L	×	0.2642	=	gal (US)
L	×	0.2200	=	gal (imp)
L	×	1.057	=	qt (US)
L	×	0.8799	=	qt (imp)
L	×	2.113	=	pint (US)
L	×	1.816	=	pint (imp)
mL	×	0.03381	=	oz (US)
mL	×	0.02816	=	oz (imp)
mL	×	0.06102	=	cu in

Units of Force:

N	×	0.1020	=	kg
N	×	0.2248	=	lb
kg	×	9.807	=	N
kg	×	2.205	=	lb

Units of Length:

km	×	0.6214	=	mile
m	×	3.281	=	ft
mm	×	0.03937	=	in

Units of Torque:

N·m	×	0.1020	=	kg·m
N·m	×	0.7376	=	ft·lb
N·m	×	8.851	=	in·lb
kg·m	×	9.807	=	N·m
kg·m	×	7.233	=	ft·lb
kg·m	×	86.80	=	in·lb

Units of Pressure:

kPa	×	0.01020	=	kg/cm ²
kPa	×	0.1450	=	psi
kPa	×	0.7501	=	cmHg
kg/cm ²	×	98.07	=	kPa
kg/cm ²	×	14.22	=	psi
cm Hg	×	1.333	=	kPa

Units of Speed:

km/h	×	0.6214	=	mph
------	---	--------	---	-----

Units of Power:

kW	×	1.360	=	PS
kW	×	1.341	=	HP
PS	×	0.7355	=	kW
PS	×	0.9863	=	HP

Units of Temperature:

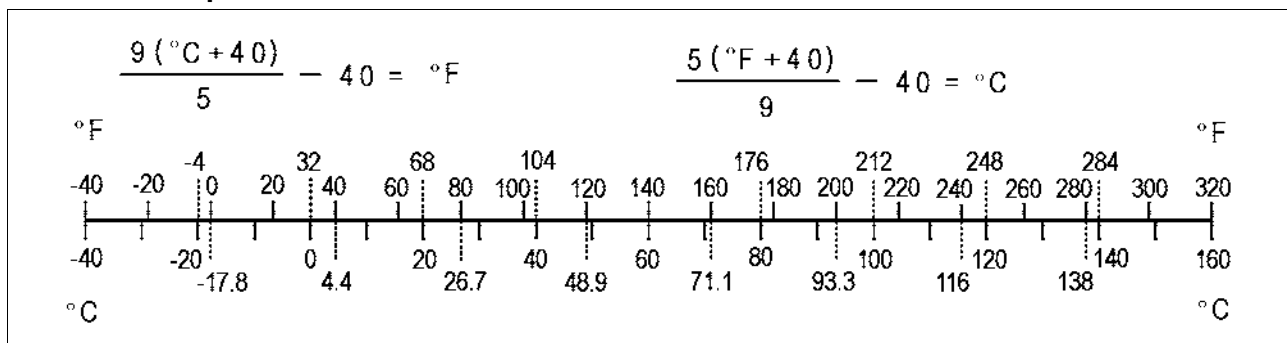

Periodic Maintenance

Table of Contents

Periodic Maintenance Chart.....	2-2	Front Final Gear Case Oil Change.....	2-19
Torque and Locking Agent.....	2-3	Rear Final Gear Case Oil Change.....	2-20
Specifications.....	2-8	Joint Boots Inspection.....	2-20
Periodic Maintenance Procedures.....	2-10	Rear Propeller Shaft Joint Boot Inspection.....	2-20
Fuel System.....	2-10	Brakes.....	2-21
Throttle Lever Free Play Inspection.....	2-10	Front Brake Pad Wear Inspection.....	2-21
Throttle Lever Free Play Adjustment.....	2-10	Brake Hose and Connection Check.....	2-21
Fuel System Cleanliness Inspection.....	2-11	Brake Hose Replacement.....	2-21
Air Cleaner Element Cleaning and Inspection..	2-11	Brake Fluid Level Inspection.....	2-21
Air Cleaner Draining.....	2-12	Brake Fluid Change.....	2-22
Fuel Hose and Connection Check.....	2-12	Brake Master Cylinder Piston Assembly and Dust Seal Replacement.....	2-22
Fuel Hose Replacement.....	2-12	Caliper Piston Seal and Dust Seal Replacement	2-23
Engine Top End.....	2-13	Rear Brake Plates Replacement.....	2-23
Valve Clearance Inspection.....	2-13	Rear Brake Lever Free Play Inspection.....	2-23
Spark Arrester Cleaning.....	2-13	Brake Pedal Free Play Inspection.....	2-23
Converter System.....	2-14	Rear Brake Lever and Pedal Free Play Adjustment.....	2-23
Actuator Lever (Engine Brake Control Lever) Assembly Inspection.....	2-14	Steering.....	2-24
Drive Belt Inspection.....	2-14	Steering Inspection.....	2-24
Drive Belt Deflection Inspection.....	2-15	Electrical System.....	2-24
Drive Belt Deflection Adjustment.....	2-16	Battery Inspection.....	2-24
Engine Lubrication System.....	2-17	Spark Plug Cleaning / Inspection.....	2-24
Engine Oil Change.....	2-17	Spark Plug Gap Inspection.....	2-24
Oil Filter Change.....	2-17	Drive Belt Failure Detection System Inspection	2-24
Oil Cooler Cleaning and Inspection.....	2-17	Brake Light Switch Adjustment.....	2-24
Oil Hose and Connection Check.....	2-18	General Lubrication.....	2-26
Wheels/Tires.....	2-18	Lubrication.....	2-26
Tire Inspection.....	2-18	Bolts and Nuts Tightening.....	2-27
Final Drive.....	2-19	Tightness Inspection.....	2-27
Variable Differential Control Lever Position Inspection.....	2-19		
Variable Differential Control Lever Position Adjustment.....	2-19		

2-2 PERIODIC MAINTENANCE

Periodic Maintenance Chart

The scheduled maintenance must be done in accordance with this chart to keep the vehicle in good running condition. **The initial maintenance is vitally important and must not be neglected.**

FREQUENCY	First Service	Regular Service			
	After 10 hrs. or 100 km (60 mi.) of use	Every 10 days or 200 km (120 mi.) of use	Every 30 days or 600 km (360 mi.) of use	Every 90 days or 1700 km (1100 mi.) of use, or when BELT indicator light comes on (100 hrs.) whichever comes first	Every year of use
OPERATION					
ENGINE					
Converter drive belt wear – inspect *				●	
Converter drive belt deflection - inspect *				●	
Drive belt failure detection system function – inspect*				● (NOTE)	
Engine brake control lever – inspect*				●	
Air cleaner – service*	●	●			
Throttle lever play – inspect	●	●			
Valve clearance – inspect					●
Fuel system cleanliness – inspect*	●			●	
Engine oil – change *	●			●	
Oil filter – replace*	●			●	
Spark plug – clean and gap	●			●	
Spark arrester – clean					●
Oil cooler– clean*	●	●			
Oil hoses and connections – inspect*					●
Fuel hoses and connections – inspect				●	
Fuel hose – replace	4 years				
CHASSIS					
Joint boots – inspect*	●	●			
Rear brake pedal and lever adjustment – inspect*	●	●			
Rear brake plates – change*	every 10 000 km (6 000 mi.)				
Cables adjustment*	●	●			
Bolts and nuts – tighten	●	●			
Front brake pad wear – inspect*	●		●		
Brake light switch – inspect*	●		●		
Battery – inspect	●		●		
Steering – inspect	●			●	
Differential control lever play– inspect	●	●			
Tire wear – inspect*			●		
Front and rear final gear case oil – change	●				●
General lubrication*			●		
Front brake fluid level – inspect	●		●		
Front brake fluid – change					●
Brake master cylinder piston assembly and dust seal – replace	2 years				
Caliper piston seal and dust seal – replace	2 years				
Brake hoses and connections– inspect				●	
Brake hose – replace	4 years				

*: Service more frequently when operated in mud, dust, or other harsh riding conditions, or when carrying heavy loads or pulling a trailer.

●: Clean, adjust, lubricate, torque, or replace parts as necessary.

NOTE

- When the drive belt failure detection system is activated, inspect the drive belt.

Torque and Locking Agent

The following tables list the tightening torque for the major fasteners, and the parts requiring use of a non-permanent locking agent or liquid gasket.

Letters used in the "Remarks" column mean:

- L: Apply a non-permanent locking agent.
- LB: Apply a non-permanet locking agent (Three Bond TB2471, Blue).
- MO: Apply molybdenum disulfide oil solution (mixture of the engine oil and molybdenum disulfide grease in a weight ratio 10:1).
- EO: Apply engine oil.
- M: Apply molybdenum disulfide grease.
- SS: Apply silicone sealant (Kawasaki Bond: 56019-120).
- Lh: Left-hand Threads
- R: Replacement Parts
- S: Follow the specific tightening sequence.
- St: Stake the fasteners to prevent loosening.

Fastener	Torque			Remarks
	N·m	kgf·m	ft·lb	
Fuel System:				
Throttle Cable Locknut	1.3	0.13	11 in·lb	
Air Cleaner Duct Front Clamp Screw	1.4	0.14	12 in·lb	
Air Cleaner Duct Rear Clamp Screw	4	0.41	36 in·lb	
Air Cleaner Housing Mounting Bolts	6.9	0.7	61 in·lb	
Air Cleaner Intake Duct Clamp Screws	1.4	0.14	12 in·lb	
Engine Top End:				
Camshaft Chain Tensioner Mounting Bolts	8.8	0.9	78 in·lb	
Camshaft Sprocket Bolts	14	1.4	10	L
Camshaft Cover Bolts	8.8	0.9	78 in·lb	
Bearing Retainer Bolts	12	1.2	104 in·lb	
Camshaft Chain Guard Bolts	8.8	0.9	78 in·lb	
Rear Camshaft Chain Guide Bolt	9.8	1.0	87 in·lb	
Cylinder Head Bolts (M11), first torque	25	2.5	18	MO, S
Cylinder Head Bolts (M11), final torque	44	4.5	33	S
Cylinder Head Bolts (M6)	12	1.2	104 in·lb	S
Valve Adjusting Screw Locknuts	12	1.2	104 in·lb	
Valve Adjusting Cap Bolts	8.8	0.9	78 in·lb	
Muffler Mounting Bolts	26	2.7	20	
Converter System:				
Converter Cover Bolts	8.8	0.9	78 in·lb	S
Driven Pulley Nut	93	9.5	69	
Ramp Weight Nuts	6.9	0.7	61 in·lb	
Spider	275	28	203	Lh
Drive Pulley Cover Bolts	13	1.3	113 in·lb	
Drive Pulley Bolt	93	9.5	69	R, Lh
Converter Air Duct Bolts	8.8	0.9	78 in·lb	
Recoil Starter:				
Recoil Starter Mounting Bolts	5.9	0.6	52 in·lb	L
Engine Lubrication System:				
Engine Drain Plug	20	2.0	14	
Oil Filter	18	1.8	13	R
Oil Pressure Switch	15	1.5	11	SS
Oil Pressure Relief Valve	15	1.5	11	L
Oil Pump Cover Bolt	20	2.0	14	
Oil Pump Cover Screws	5.4	0.55	48 in·lb	
Oil Pipe Bolts	8.8	0.9	78 in·lb	

2-4 PERIODIC MAINTENANCE

Torque and Locking Agent

Fastener	Torque			Remarks
	N·m	kgf·m	ft·lb	
Oil Pipe Joint Nuts	29	3.0	22	
Oil Cooler Mounting Bolts	8.8	0.9	78 in·lb	
Oil Cooler Fan Switch	16	1.6	12	
Oil Temperature Warning Light Switch	16	1.6	12	
Oil Filter Mounting Bolt	25	2.5	18	L
Oil Hose Banjo Bolts	29	3.0	22	
Oil Pressure Switch Terminal Bolt	1.5	0.15	13 in·lb	
Engine Removal/Installation				
Engine Mounting Bracket Bolts	25	2.5	18	
Engine Mounting Nuts	42	4.3	31	
Engine Mounting Upper Bolt	25	2.5	18	
Crankshaft/Transmission:				
Crankcase Bolts (M8)	20	2.0	14	S, L (1)
Crankcase Bolts (M6)	8.8	0.9	78 in·lb	
Shift Shaft Positioning Bolt	25	2.5	18	
Tie-Rod End Locknut	20	2.0	14	
Tie-Rod End Bolt	9.8	1.0	87 in·lb	
Shift Lever Assembly Nut	20	2.0	14	
Tie-Rod End Nut	20	2.0	14	
Shift Lever Assembly Bracket Bolts	20	2.0	14	
Tie-Rod End Rear Locknut	9.8	1.0	87 in·lb	
Tie-Rod End Front Locknut	9.8	1.0	87 in·lb	Lh
Grip Hold Nut	9.8	1.0	87 in·lb	
Shift Shaft Spring Bolt	25	2.5	18	L
Shift Shaft Cover Bolts	8.8	0.9	78 in·lb	
Oil Line Plugs	23	2.3	17	L
Wheels/Tires:				
Tie-Rod Adjusting Sleeve Locknuts	37	3.8	27	
Wheel Nuts	52	5.3	38	
Front Axle Nuts	196	20	145	
Rear Axle Nuts	265	27	195	
Final Drive:				
(Output Bevel Gears)				
Output Drive Bevel Gear Housing Bolts	26	2.7	20	
Rotor Mounting Bolts	12	1.2	104 in·lb	
Output Drive Bevel Gear Cover Bolts	8.8	0.9	78 in·lb	
Forward/Reverse Detecting Sensor Mounting Bolts	15	1.5	11	
Bearing Holder	118	12	87	L
Bevel Gear Holder Nut	157	16	116	L
Output Drive Bevel Gear Housing Bolts	26	2.7	20	
Bearing Holder	137	14	101	L
Output Shaft Holder Nut	157	16	116	L
(Front Final Gear Case)				
Oil Filler Cap	29	3.0	22	
Oil Drain Plug	24	2.4	17	
Variable Differential Control Cable Locknut	17	1.7	12	
Front Final Gear Case Bolts and Nuts	42	4.3	31	
Front Final Gear Case Center Cover Bolts (M8)	24	2.4	17	L, S
Front Final Gear Case Center Cover Bolts (M6)	9.8	1.0	87 in·lb	L, S
Pinion Gear Bearing Holder	137	14	101	L
Front Final Gear Case Left Cover Bolts (M6)	9.8	1.0	87 in·lb	S, L (4)

PERIODIC MAINTENANCE 2-5

Torque and Locking Agent

Fastener	Torque			Remarks
	N·m	kgf·m	ft·lb	
Front Final Gear Case Coupling Nut	20	2.0	14	
Variable Front Differential Control Shift Shaft Lever	8.8	0.9	78 in·lb	
Ring Gear Bolts	57	5.8	42	LB
Pinion Gear Bearing Holder Nut	127	13	94	St
(Rear Axle)				
Bearing Holder	255	26	188	M
Bearing Holder Screws	16	1.6	12	L
(Rear Final Gear Case)				
Oil Filler Cap	29	3.0	22	
Oil Drain Plug	20	2.0	14	
Rear Final Gear Case Bolts	42	4.3	31	S
Pinion Gear Bearing Holder	137	14	101	L
Rear Final Gear Case Right Cover Bolts (M10)	49	5.0	36	L
Rear Final Gear Case Right Cover Bolts (M8)	24	2.4	17	L
Pinion Gear Bearing Holder Nut	157	16	116	L
Brakes:				
Reservoir Cap Screws	1.5	0.15	13 in·lb	
Bleed Valves	5.9	0.6	52 in·lb	
Master Cylinder Clamp Bolts	8.8	0.9	78 in·lb	
Brake Hose Banjo Bolts	25	2.5	18	
Brake Lever Pivot Bolt	5.9	0.6	52 in·lb	
Brake Lever Pivot Bolt Locknut	5.9	0.6	52 in·lb	
Caliper Mounting Bolts	25	2.5	18	
Caliper Holder Shaft	18	1.8	13	
Caliper Holder Shaft (Allen Bolt)	23	2.3	17	
Pad Mounting Bolts	18	1.8	13	
Disc Mounting Bolts	37	3.8	27	L
Suspension:				
Front Shock Absorber Clamp Bolts and Nuts	47	4.8	35	
Front Shock Absorber Mounting Nuts	74	7.5	54	
Rear Shock Absorber Mounting Nuts	62	6.3	46	
Piston Rod Nut	49	5.0	36	
Suspension Arm Pivot Bolts	88	9.0	65	
Swingarm Pivot Right Shaft	152	15.5	112	L
Swingarm Pivot Left Shaft	20	2.0	14	
Swingarm Pivot Left Nut	152	15.5	112	
Steering:				
Steering Stem Bottom End Nut	62	6.3	46	
Steering Stem Clamp Bolts	25	2.5	18	
Tie-Rod End Nuts	42	4.3	31	
Steering Knuckle Joint Nuts	47	4.8	35	
Front Shock Absorber Clamp Bolts and Nuts	47	4.8	35	
Tie-Rod Adjusting Sleeve Locknuts	37	3.8	27	
Handlebar Lower Holder Nuts	37	3.8	27	L
Handlebar Holder Bolts	27	2.8	20	S
Frame:				
Rear Carrier Bolts and Nuts	25	2.5	18	
Front Carrier Bolts	–	–	–	L
Front Guard Bolts	20	2.0	14	
Trailer Hitch Bracket Bolts (M10)	49	5.0	36	L
Trailer Hitch Bracket Bolts (M8)	24	2.4	17	L

2-6 PERIODIC MAINTENANCE

Torque and Locking Agent

Fastener	Torque			Remarks
	N·m	kgf·m	ft·lb	
Footboard Mounting Nuts	–	–	–	L
Electrical System:				
Alternator Cover Bolts	8.8	0.9	78 in·lb	
Alternator Rotor Bolts	127	13	94	
Alternator Stator Bolts	14	1.4	10	
Spark Plug	14	1.4	10	
Ignition Coil Mounting Bolt	8.8	0.9	78 in·lb	
Pickup Coil Mounting Bolts	5.9	0.6	52 in·lb	
Starter Motor Mounting Bolts	8.8	0.9	78 in·lb	
Starter Motor Terminal Nut	4.9	0.5	43 in·lb	
Starter Motor Terminal Locknut	6.9	0.7	61 in·lb	
Starter Motor Bolts	3.4	0.3	30 in·lb	
Starter Motor Clutch Bolts	34	3.5	25	L
2WD/4WD Actuator Mounting Bolts	9.8	1.0	87 in·lb	L, S
Engine Brake Actuator Mounting Bolts	8.8	0.9	78 in·lb	
Reverse Position Switch	15	1.5	11	
Neutral Switch	15	1.5	11	
Starter Relay Terminal Nuts	4.9	0.5	43 in·lb	
Igniter Mounting Bolts	2.3	0.23	20 in·lb	
Ignition Switch Nut	2.7	0.28	24 in·lb	
Oil Pressure Switch Terminal Bolt	1.5	0.15	13 in·lb	
Regulator/Rectifier Mounting Bolts	8.8	0.9	78 in·lb	

Torque and Locking Agent

The tables below, relating tightening torque to thread diameter, lists the basic torque for the bolts and nuts. Use this table for only the bolts and nuts which do not require a specific torque value. All of the values are for use with dry solvent-cleaned threads.

Basic Torque for General Fasteners of Engine Parts

Threads dia. mm (in.)	Mark of bolt head	Torque		
		N·m	kgf·m	ft·lb
6 (0.24)	9T	12 ~ 15	1.2 ~ 1.5	104 ~ 130 in·lb
6 (0.24)	7T	7.8 ~ 9.8	0.8 ~ 1.0	69 ~ 87 in·lb
6 (0.24)	4T	3.9 ~ 4.9	0.4 ~ 0.5	35 ~ 43 in·lb
8 (0.31)	7T	18 ~ 22	1.8 ~ 2.2	13 ~ 16
8 (0.31)	4T	10 ~ 14	1.0 ~ 1.4	87 ~ 122 in·lb
10 (0.39)	7T	39 ~ 44	4.0 ~ 4.5	29 ~ 33
10 (0.39)	4T	20 ~ 24	2.0 ~ 2.4	14 ~ 17
5 (0.20)	4T	2.2 ~ 2.6	0.22 ~ 0.27	19 ~ 23 in·lb

Basic Torque for General Fasteners of Frame Parts

Threads dia. mm (in.)	Torque		
	N·m	kgf·m	ft·lb
5 (0.20)	3.4 ~ 4.9	0.35 ~ 0.5	30 ~ 43 in·lb
6 (0.24)	5.9 ~ 7.8	0.6 ~ 0.8	52 ~ 69 in·lb
8 (0.31)	14 ~ 19	1.4 ~ 1.9	10.0 ~ 13.5
10 (0.39)	25 ~ 34	2.6 ~ 3.5	19.0 ~ 25
12 (0.47)	44 ~ 61	4.5 ~ 6.2	33 ~ 45
14 (0.55)	73 ~ 98	7.4 ~ 10.0	54 ~ 72
16 (0.63)	115 ~ 155	11.5 ~ 16.0	83 ~ 115
18 (0.71)	165 ~ 225	17.0 ~ 23.0	125 ~ 165
20 (0.79)	225 ~ 325	23 ~ 33	165 ~ 240

2-8 PERIODIC MAINTENANCE

Specifications

Item	Standard	Service Limit
Fuel System: Throttle lever free play Air cleaner element oil	2 ~ 3 mm (0.08 ~ 0.12 in.) High-quality foam air filter oil	--- ---
Engine Top End: Valve clearance: Exhaust Inlet	0.15 ~ 0.20 mm (0.0059 ~ 0.0079 in.) 0.08 ~ 0.13 mm (0.0032 ~ 0.0051 in.)	--- ---
Converter System: Actuator lever guide shoe wear Belt width Belt deflection	--- 29.8 ~ 31.0 mm (1.17 ~ 1.22 in.) 20 ~ 27 mm (0.79 ~ 1.06 in.)	6 mm (0.24 in.) 29.4 mm (1.16 in.) ---
Engine Lubrication System: Engine oil: Type Viscosity Capacity	API SF or SG API SH or SJ with JASO MA SAE10W40 1.50 L (1.59 US qt) (When filter is not removed) 1.74 L (1.84 US qt) (When filter is removed) 2.3 L (2.43 US qt) (When engine is completely dry)	--- --- --- --- ---
Wheels/Tires Tire tread depth: Front Rear Standard tire: Front Rear	--- --- AT 25 X 8-12 Dunlop, KT121, Tubeless AT 25 x 10-12 Dunlop, KT405C/KT127A, Tubeless	3 mm (0.12 in.) 4 mm (0.16 in.) --- --- ---
Final Drive: Front Final Gear Case: Gear Case Oil: Type Viscosity Oil level Capacity Rear Final Gear Case: Gear Case Oil: Type Oil level Capacity	API SF or SG API SH or SJ of JASO MA SAE 10W-40 Filler opening bottom 430 mL (0.45 US qt) MOBIL Fluid 424 or Kawa Chem Gear & Wet Brake Oil (CITGO TRANSGARD TRACTOR HYDRAULIC FLUID) Filler opening bottom 900 mL (0.95 US qt)	--- --- --- --- --- --- --- --- ---
Brakes: Front Brake Fluid: Type Front Disc Brake: Pad lining thickness Rear Brake Lever, Pedal and Cables: Rear brake lever free play Brake pedal free play	DOT 3 or DOT 4 4.5 mm (0.18 in.) 1 ~ 2 mm (0.04 ~ 0.08 in.) 15 ~ 25 mm (0.6 ~ 1.0 in.)	--- 1 mm (0.04 in.) --- ---
Electrical System: Spark plug gap Rear brake light switch timing	0.8 ~ 0.9 mm (0.031 ~ 0.035 in.) On after 10 mm (0.4 in.) of pedal travel	--- ---

Specifications

Special Tools - Carburetor Drain Plug Wrench, Hex 3: 57001-1269

Belt Measuring Gauge: 57001-1519

Flywheel & Pulley Holder: 57001-1343

Pulley Holder Attachment: 57001-1472

Oil Filter Wrench: 57001-1249

2-10 PERIODIC MAINTENANCE

Periodic Maintenance Procedures

Fuel System

Throttle Lever Free Play Inspection

- Check that the throttle lever moves smoothly from full open to close, and the throttle closes quickly and completely in all steering positions by the return spring.
- ★ If the throttle lever does not return properly, check the throttle cable routing, lever free play, and for possible cable damage. Then lubricate the throttle cable.
- Run the engine at the idle speed, and turn the handlebar all the way to the right and left to ensure that the idle speed does not change.
- ★ If the idle speed increases, check the throttle lever free play and the cable routing.
- Stop the engine and check the throttle lever free play [A].
- ★ If the free play is not within the specified range, adjust the cable.

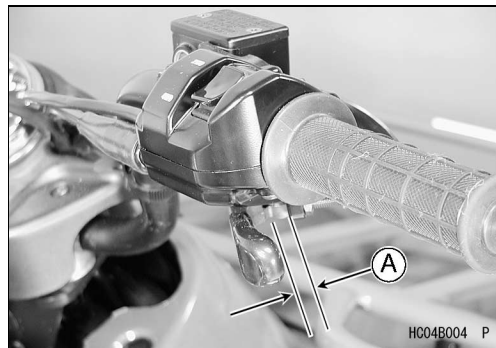

Throttle Lever Free Play

Standard: 2 ~ 3 mm (0.08 ~ 0.12 in.)

Throttle Lever Free Play Adjustment

- Slide the rubber cover off the adjuster at the throttle case.
- Loosen the locknut [A] and turn the throttle cable upper adjuster [B] until the cable has proper amount of play.
- Tighten the locknut and reinstall the rubber cover.

Torque - Throttle Cable Locknut: 13 N·m (0.13 kgf·m, 11 in·lb)

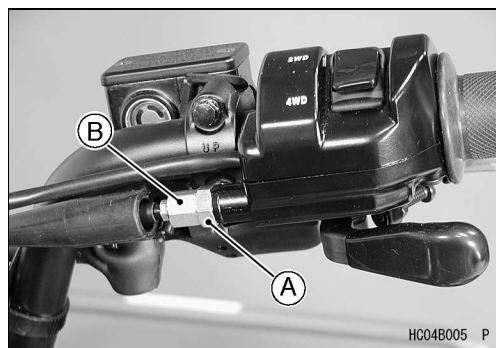

- ★ If the free play cannot be adjusted by using the upper cable adjuster, remove the throttle cable pulley cover and then use the cable adjusting nuts [A] at the lower end of the throttle cable and make the necessary free play.

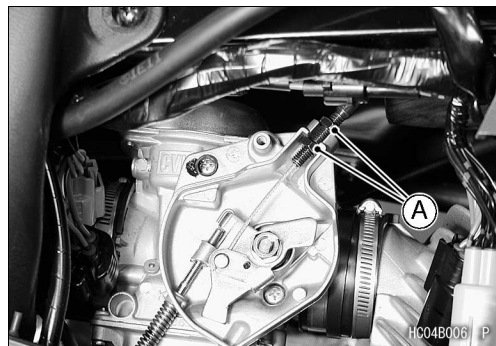

Periodic Maintenance Procedures

Fuel System Cleanliness Inspection

WARNING
Gasoline is extremely flammable and can be explosive under certain conditions. Turn the ignition switch OFF. Do not smoke. Make sure the area is well ventilated and free from any source of flame or sparks; this includes any appliance with a pilot light.

- Turn the fuel tap to the OFF position.
 - Remove the check valve [A] at the end of the carburetor overflow hose.
 - Run the lower end of the carburetor overflow hose to a suitable container.
 - Turn out the carburetor drain plug a few turns and drain the fuel system.
- Special Tool - Carburetor Drain Plug Wrench, Hex 3: 57001-1269 [A]**
- Check to see if water or dirt comes out.
 - Tighten the drain plug.
 - ★ If any water or dirt appears during the above inspection, clean the fuel system (carburetor, tank, fuel hose).

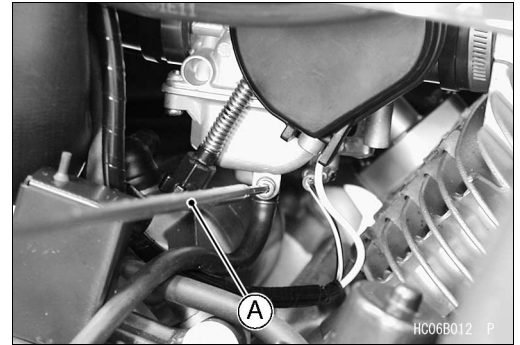
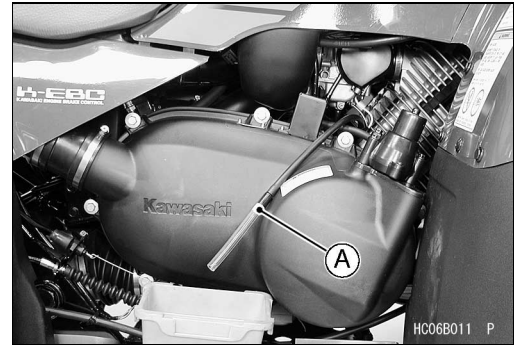

Air Cleaner Element Cleaning and Inspection

NOTE

- In dusty areas, the element should be cleaned more frequently than the recommended interval.
- After riding through rain or muddy terrains, the element should be cleaned immediately.
- Also, if there is a break in the element material or any other damage to the element, replace the element with a new one.

WARNING
Clean the element in a well-ventilated area, and take care that there are no sparks or flame anywhere near the working area; this includes any appliance with a pilot light. Because of the danger of highly flammable liquids, do not use gasoline or a low-flash point solvent to clean the foam element.

- Remove the air cleaner element.
- Clean the element in a bath of high-flash point solvent using a soft bristle brush.
- Squeeze it dry in a clean towel [A]. Do not wring the element or blow it dry; the element can be damaged.
- Inspect the element for damage.
- ★ If it is torn, punctured, or hardened, replace it.

NOTE

- Replace the element after cleaning it five times or if it is damaged.
- After cleaning, saturate the element with a high-quality foam-air-filter oil, squeeze out the excess oil, then wrap it in a clean rag and squeeze it as dry as possible. Be careful not to tear the element.

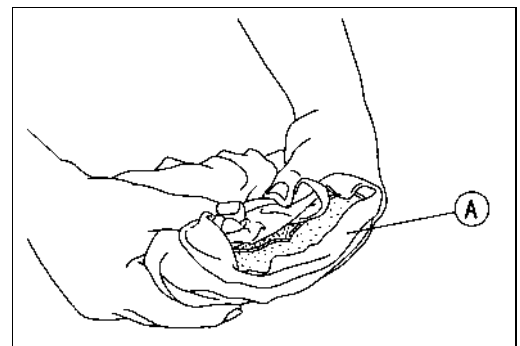

2-12 PERIODIC MAINTENANCE

Periodic Maintenance Procedures

Air Cleaner Draining

A drain tube [A] is connected to the bottom of the air cleaner housing to drain water or oil accumulated in the housing.

- Visually check the drain tube if the water or oil accumulates in the tube.
- ★ If any water or oil accumulates in the tube, drain it by taking off the tube. After draining, be sure to install the tube and clamp firmly.



Fuel Hose and Connection Check

- Turn the fuel tap to the OFF position.
- Remove:
 - Fuel Tank Cover (see Frame chapter)
 - Exhaust Cover (see Frame chapter)
- Check the fuel hose [A].
- ★ If the fuel hose is frayed, cranked, or bulged, replace the fuel hose.
- Check that the hose is securely connected and clamps [B] are tightened.
- ★ If the fuel hose has been sharply bent or kinked, replace the fuel hose.
- ★ If the clamps are loosened or damaged, replace the clamps.
- When installing the fuel hose, route the hose according to Cable, Wire, and Hose Routing section in Appendix chapter.
- When installing the fuel hose, avoid sharp bending, kinking, flattening or twisting, and route the fuel hose with a minimum of bending so that the fuel flow will not be obstructed.

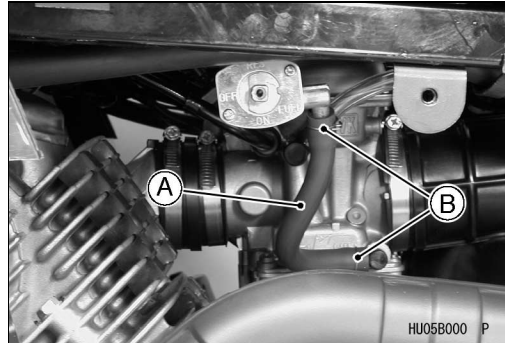

Fuel Hose Replacement

⚠ WARNING

Gasoline is extremely flammable and can be explosive under certain conditions. Turn the ignition switch OFF. Do not smoke. Make sure the area is well ventilated and free from any source of flame or sparks; this includes any appliance with a pilot light.

- Turn the fuel tap to the OFF position.
- Remove:
 - Fuel Tank Cover (see Frame chapter)
 - Exhaust Cover (see Frame chapter)
 - Clamps [A]
 - Fuel Hose [B]
- Fit the fuel hose [A] onto the pipe fully and install the clamps [B] beyond the raised rib [C].

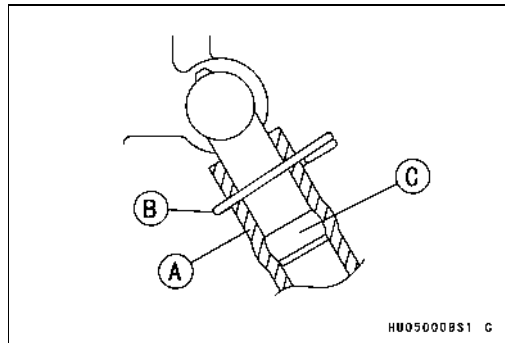
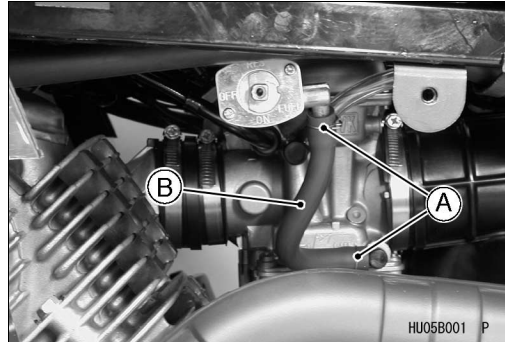

Periodic Maintenance Procedures

Engine Top End

Valve Clearance Inspection

NOTE

- Check the valve clearance only when the engine is cold (at room temperature).
- Remove:
 - Left Front Wheel (see Wheels/Tires chapter)
 - Left Front Inner Cover (see Frame chapter)
 - Fuel Tank (see Fuel System chapter)
 - Rubber Cover
 - Bolts [A] and Valve Adjusting Caps [B]
- Remove:
 - Recoil Starter (see Recoil Starter chapter)
 - Timing Inspection Plug
- Position the crankshaft at TDC of the end of the compression stroke (see Camshaft Sprocket Installation in Engine Top End chapter).
- Measure the clearance of each valve between the end of the valve stem and the adjusting screw on the rocker arm with a thickness gauge [A].
- ★ If the valve clearance is not correct, adjust it (see Engine Top End chapter).

Valve Clearance (when cold)

Exhaust:	0.15 ~ 0.20 mm (0.0059 ~ 0.0079 in.)
Inlet:	0.08 ~ 0.13 mm (0.0032 ~ 0.0051 in.)

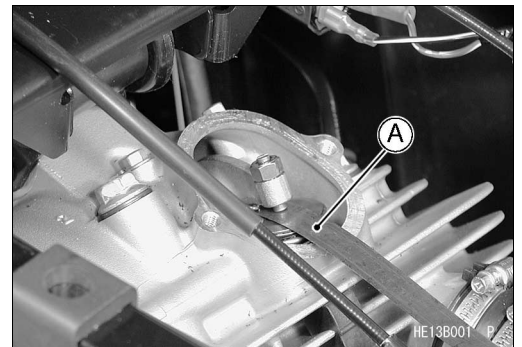
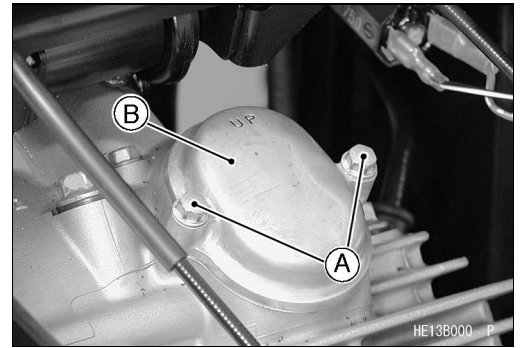

Spark Arrester Cleaning

⚠ WARNING

To avoid burns, wear gloves while cleaning the spark arrester. Since the engine must be run during this procedure, the muffler will become hot.

- Remove the drain plug [A] on the muffler.
- In an open area away from combustible materials, start the engine with the transmission in neutral.
- Raise and lower engine speed while tapping on the muffler with a rubber mallet until carbon particles are purged from the muffler.

⚠ WARNING

Do not run the engine in a closed area. Exhaust gases contain carbon monoxide; a colorless, odorless, poisonous gas. Breathing exhaust gas leads to carbon monoxide poisoning, asphyxiation, and death.

- Stop the engine.
- Install the drain plug.

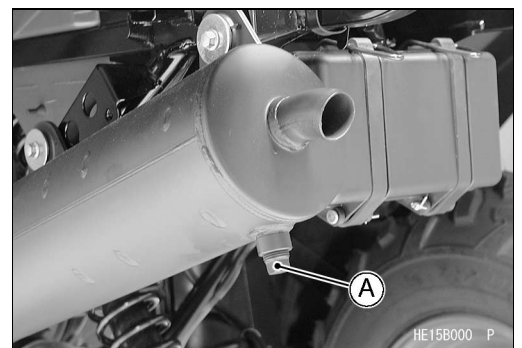

2-14 PERIODIC MAINTENANCE

Periodic Maintenance Procedures

Converter System

Actuator Lever (Engine Brake Control Lever) Assembly Inspection

- Measure the width [A] of the guide [B].
- ★ If the guide contact area width is greater than the service limit, replace the actuator lever assembly.

Actuator Lever Guide Shoe Wear
Service Limit: 6 mm (0.24 in.)

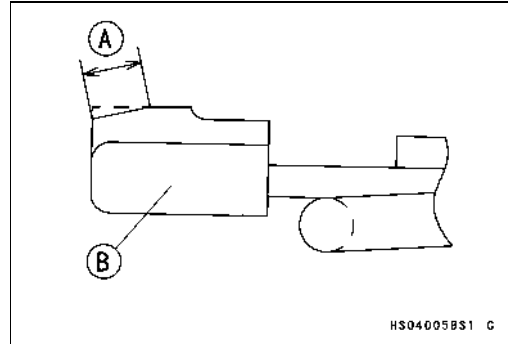

Drive Belt Inspection

Inspection of the drive belt is required at least every 90 days of vehicle use (average 12 mile/day) not to exceed 1,100 mile. More frequent inspection is necessary if the vehicle is subjected to hard usage.

⚠ WARNING

Neglect, abuse, or failure to maintain the transmission can result in a severely worn or damaged drive belt locking up the transmission and wheels. This can cause the operator to lose control and have an accident resulting in injury or death.

- Measure the width [A] of the belt at several locations with a suitable straightedge [B] as shown.
- ★ If any measurements exceed the service limit, replace the belt.

Belt Width
Standard: 29.8 ~ 31.0 mm (1.17 ~ 1.22 in.)
Service Limit: 29.4 mm (1.16 in.)

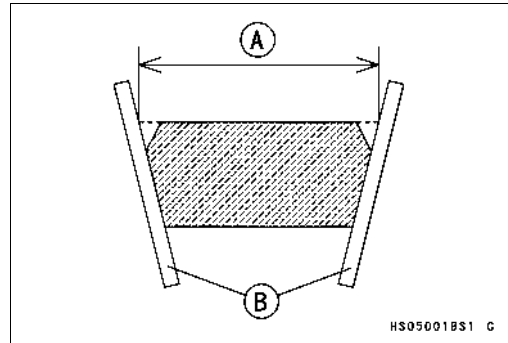

NOTE

- Use the belt measuring gauge [A] in order to make easy to inspect the drive belt width.

Special Tool - Belt Measuring Gauge: 57001-1519

- Fit the drive belt [B] into the belt measuring gauge.
- ★ If the upper surface [C] of the belt sank in the upper surface [D] of the gauge, replace the belt.

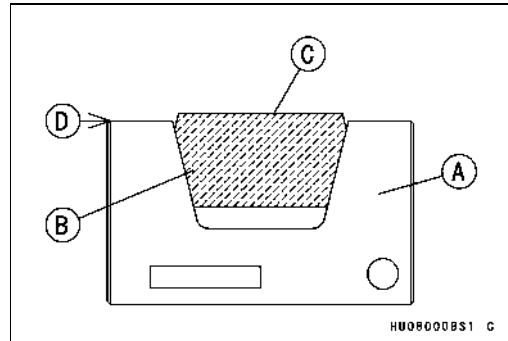

- Check the belt [A] for abnormal wear [B].
- Measure the width [C] of the belt at abnormal wear point.
- ★ If any measurements exceed 0.5 mm (0.02 in.), replace the belt.
- When using the belt of large abnormal wear, the drive belt failure detection switch could be activated.

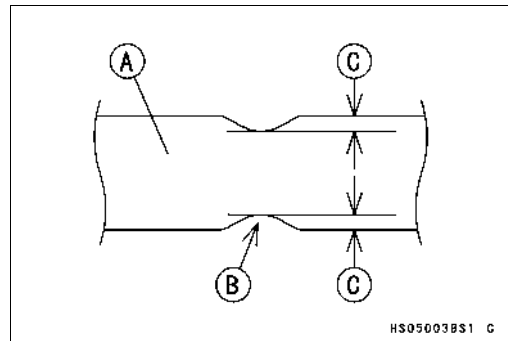

Periodic Maintenance Procedures

- Check the belt for cracks, breaks, or peeling.
- ★ If necessary, replace the belt with a new one.
 - Belt [A]
 - Crack [B]
 - Broken [C]
 - Peeling [D]

NOTE

- Whenever the belt is replaced, inspect the drive and the driven pulleys.

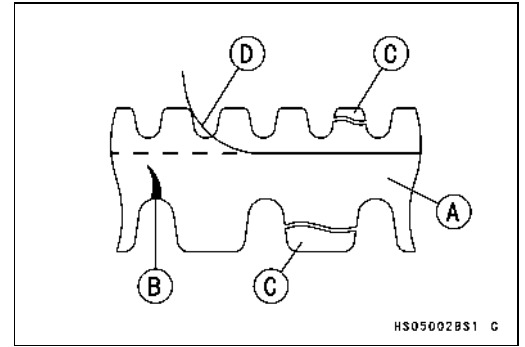

Drive Belt Deflection Inspection

NOTE

- If the drive belt failure detection system is activated by abnormal belt, the drive belt failure detection switch is damaged. Make sure to replace the torque converter cover.
- Remove the torque converter cover (see Torque Converter Cover Removal in Converter System chapter).
- Put the transmission in neutral and rotate the driven pulley by hand to make sure the belt is shifted all the way to the top of the driven pulley.
- Measure the belt deflection [A] as shown:
- Place a straightedge [B] on top of the belt between the drive pulley [C] and the driven pulley [D].
- Use a ruler to push the belt away from the straightedge. Push hard, but with no more force than 59 N (6 kgf, 13 lb).

Belt Deflection

Standard: 20 ~ 27 mm (0.79 ~ 1.06 in.)

- ★ If the belt deflection is not within the specified range, first measure the drive belt width (see Drive Belt Inspection). Adjust the deflection by adding or removing spacers on the fixed sheave.
- When adjusting the deflection, less is better than more. Less deflection will maintain better performance for more time as the belt width decreases by normal wear, which causes the deflection to increase with usage.

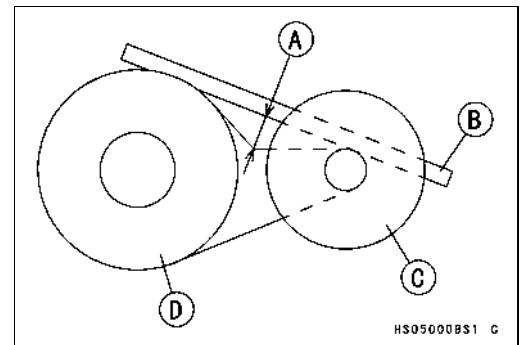

2-16 PERIODIC MAINTENANCE

Periodic Maintenance Procedures

Drive Belt Deflection Adjustment

- Disassemble the driven pulley (see Driven Pulley Disassembly in Converter System chapter).
- ★ If the belt deflection is more than 27 mm (1.06 in.), remove the spacers to decrease it.
- The rule-of-thumb is: 0.1 mm (0.004 in.) change in spacer thickness equals about 1.3 mm (0.051 in.) change in belt deflection.
- ★ If the belt deflection is less than 20 mm (0.79 in.), add the spacers [A] to increase it.
- The rule-of-thumb is: 0.1 mm (0.004 in.) change in spacer thickness equals about 1.6 mm (0.063 in.) change in belt deflection.

Spacers

Part No.	Thickness
92026-1569	0.6 mm (0.024 in.)
92026-1617	0.8 mm (0.032 in.)
92026-1565	1.0 mm (0.039 in.)
92026-1570	1.4 mm (0.055 in.)

- Assemble the driven pulley (see Driven Pulley Assembly in Converter System chapter).
- With the transmission in neutral, rotate the driven pulley to allow the belt to return to the top of the sheaves before measuring the belt deflection.
- Measure the belt deflection again and repeat the above procedures until it is within the standard range.
- Using the flywheel & pulley holder and adapter, tighten the driven pulley nut.

Special Tools - Flywheel & Pulley Holder: 57001-1343

Pulley Holder Attachment: 57001-1472

Torque - Driven Pulley Nut: 93 N·m (9.5 kgf·m, 69 ft·lb)

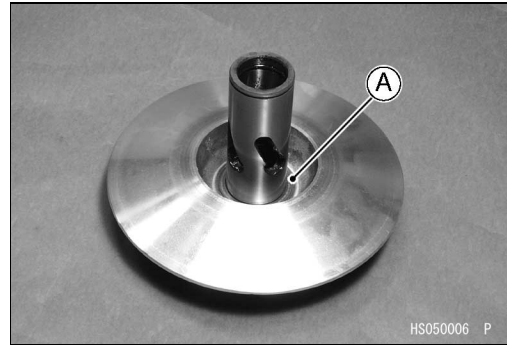

Periodic Maintenance Procedures

Engine Lubrication System

Engine Oil Change

- Support the vehicle so that it is level side to side and front to back after warming up the engine.
- Remove the engine drain plug [A] to drain the oil.
- The oil in the filter can be drained by removing the filter (see Oil Filter Change).
- ★ Replace the drain plug gasket with a new one if it is damaged.
- Tighten:
 - Torque - Engine Drain Plug : 20 N·m (2.0 kgf·m, 14 ft·lb)
- Pour in the specified type and amount of oil.

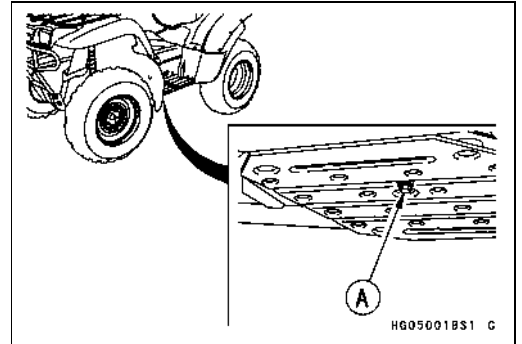

Engine Oil

- Type: API SF or SG
API SH or SJ with JASO MA
- Viscosity: SAE 10W-40
- Amount: 1.50 L (1.59 US qt) (When filter is not removed)
1.74 L (1.84 US qt) (When filter is removed)
2.3 L (2.43 US qt) (When engine is completely dry)

NOTE

- Depending on the atmospheric temperature of your riding area, the engine oil viscosity should be changed according to the chart.

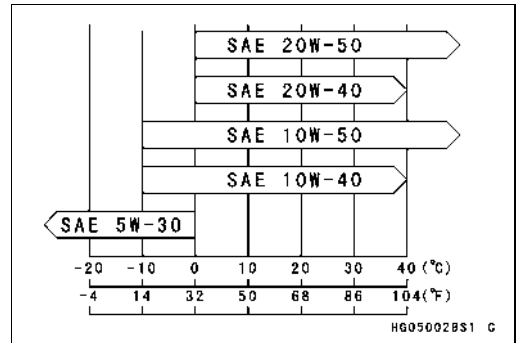

Oil Filter Change

- Drain the engine oil.
- Remove the oil filter [A] with the oil filter wrench [B].
- Special Tool - Oil Filter Wrench : 57001-1249

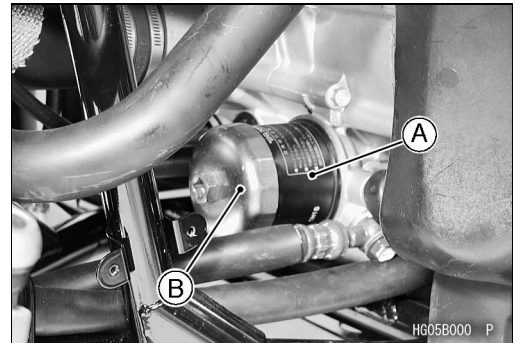

- Replace the filter with a new one.
- When installing the oil filter, be careful of the following.
- Apply oil to the gasket [A] before installation.
- Tighten the filter with the oil filter wrench.

Special Tool - Oil Filter Wrench: 57001-1249

Torque - Oil Filter : 18 N·m (1.8 kgf·m, 13 ft·lb)

- Pour in the specified type and amount of oil.

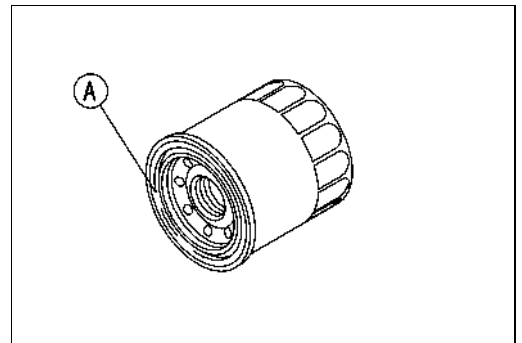

Oil Cooler Cleaning and Inspection

- Check the oil cooler [A].
- ★ If there are obstructions to air flow, remove them.
- ★ If the corrugated fins are deformed, carefully straighten them with the blade of a thin screw driver.

CAUTION

Do not tear the cooler tubes while straightening the fins.

- ★ If the air passage of the cooler core are blocked by unremovable obstructions or irreparably deformed fins, replace the oil cooler.

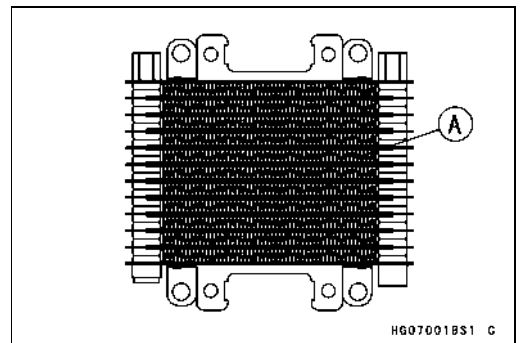

2-18 PERIODIC MAINTENANCE

Periodic Maintenance Procedures

CAUTION

When cleaning the oil cooler with compressed air, be careful of the following to avoid damage to the fins.
Keep the air nozzle [A] over 0.5 m (20 in.) [B] away from the oil cooler.
Blow air perpendicularly to the cooler core.
Never blow air at an angle against the fins but straight through them in the direction of natural air flow.
Never shake the air nozzle at a right angle against the fins; be sure to move it at a level with the fins.

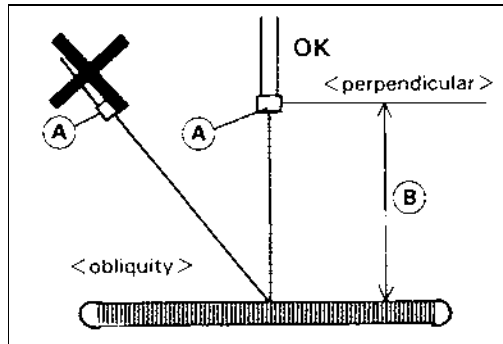

Oil Hose and Connection Check

- Remove:
 - Left Side Cover (see Frame chapter)
 - Front Inner Covers (see Frame chapter)
 - Check the oil hoses [A].
 - ★ If the oil hoses are frayed, cracked, or bulged, replace the oil hose.
 - Check that the hose is securely connected, and banjo bolts [B] and oil pipe joint nuts [C] are tightened.
 - ★ If the oil hose has been sharply bent or kinked, replace the oil hose.
- Torque - Oil Pipe Banjo Bolts: 29 N·m (3.0 kgf·m, 22 ft·lb)**
Oil Pipe Joint Nuts: 29 N·m (3.0 kgf·m, 22 ft·lb)
- When installing the oil hose, route the hose according to Cable, Wire, and Hose Routing section in Appendix chapter.
 - When installing the oil hose, avoid sharp bending, kinking, flattening or twisting, and route the oil hose with a minimum of bending so that the oil flow will not be obstructed.

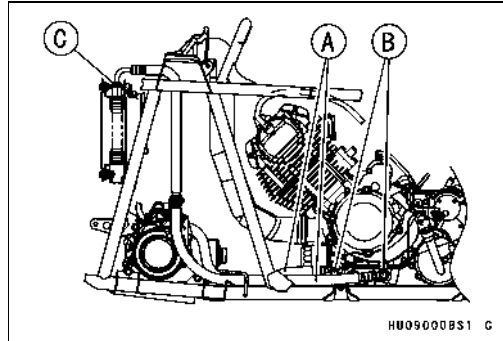

Wheels/Tires

Tire Inspection

- Examine the tire for damage and wear.
- ★ If the tire is cut or cracked, replace it.
- Lumps or high spots on the tread or sidewalls indicate internal damage requiring tire replacement.
- Remove any foreign objects from the tread. After removal, check for leaks with a soap and water solution.
- Measure the tread depth at the center of the tread with a depth gauge [A]. Since the tire may wear unevenly, take measurements at several places.
- ★ If any measurements are less than the service limit, replace the tire.

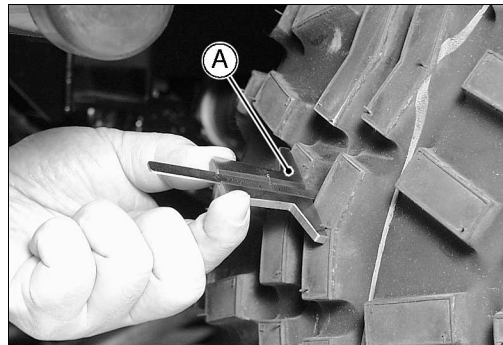

Tire Tread Depth

Service Limit:

Front:	3 mm (0.12 in.)
Rear:	4 mm (0.16 in.)

Standard Tire

Front:	AT 25 x 8 - 12 DUNLOP KT121 Tubeless
Rear:	AT 25 x 10 - 12 DUNLOP KT405C/KT127A Tubeless

Periodic Maintenance Procedures

Final Drive

Variable Differential Control Lever Position Inspection

- Pull the variable differential control lever [A] towards the handlebar grip [B] with a spring scale until it reads 30 N (3 kgf, 7 lb) of force.
- The clearance [C] between the control lever and grip should be 20 mm (0.8 in.).
- ★ If the clearance is not within the specified range, adjust the cable.

Differential Control Lever Position
Standard: 20 mm (0.8 in.)

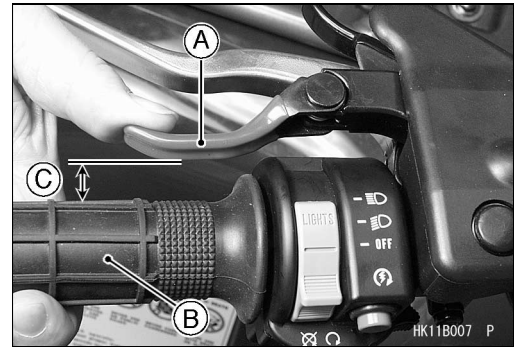

Variable Differential Control Lever Position Adjustment

- Loosen the locknut [A] of the differential control cable.
- Turn the adjuster [B] until the cable has proper amount of play.
- Tighten the locknut securely.

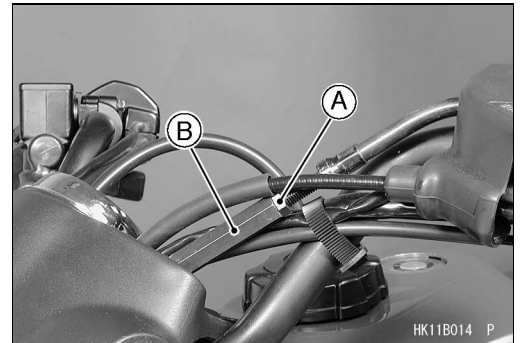

Front Final Gear Case Oil Change

- Warm up the oil by running the vehicle so that the oil will pick up any sediment and drain easily. Then stop the vehicle.
- Park the vehicle so that it is level, both side-to-side and front-to-rear.
- Remove the front side cover (see Frame chapter).
- Place an oil pan beneath the front final gear case and remove the drain plug [A].

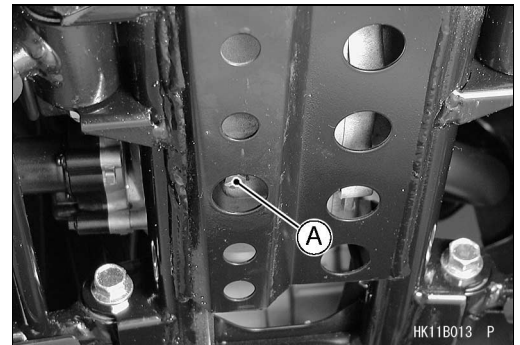

⚠ WARNING

When draining or filling the final gear case, be careful that no oil gets on the tire or rim. Clean off any oil that inadvertently gets on them with a high-flash point solvent.

- After the oil has completely drained out, install the drain plug with a new aluminum gasket, and tighten it.

Torque - Oil Drain Plug: 24 N·m (2.4 kg·m, 17 ft·lb)

- Fill the gear case up to the bottom of filler opening with the oil specified below.

Front Final Gear Case Oil
Type: API SF or SG
API SH or SJ with JASO MA
Viscosity: SAE 10W-40
Capacity: 430 mL (0.45 US qt)

NOTE

- Depending on the atmospheric temperature of your riding area, the engine oil viscosity should be changed according to the chart.

- Be sure the O-ring is in place, and tighten the filler cap.

Torque - Oil Filler Cap : 29 N·m (3.0 kg·m, 22 ft·lb)

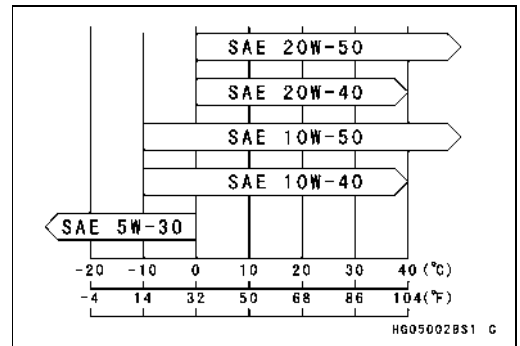

2-20 PERIODIC MAINTENANCE

Periodic Maintenance Procedures

Rear Final Gear Case Oil Change

- Warm up the oil by running the vehicle so that the oil will pick up any sediment and drain easily. Then stop the vehicle.
- Park the vehicle so that it is level, both side-to-side and front-to-rear.
- Place an oil pan beneath the rear final gear case and remove the drain plug [A].

⚠ WARNING

When draining or filling the final gear case, be careful that no oil gets on the tire or rim because oil will deteriorate the tire. Clean off any oil that inadvertently gets on them with a high-flash point solvent.

- After the oil has completely drained out, install the drain plug with a new aluminum gasket.

Torque - Oil Drain Plug: 20 N·m (2.0 kg·m, 14 ft·lb)

- Fill the final gear case up to the bottom of filler opening with the oil specified below.

Rear Final Gear Case Oil

**Type: MOBIL Fluid 424 or Kawa Chem Gear & Wet Brake Oil
(CITGO TRANSGARD TRACTOR HYDRAULIC FLUID)**

Capacity: 900 mL (0.95 US qt)

- Be sure the O-ring is in place.

Torque - Oil Filler Cap [B]: 29 N·m (3.0 kg·m, 22 ft·lb)

Joint Boots Inspection

- Visually inspect the front axle joint boots in accordance with the Periodic Maintenance Chart or if the axles are noisy during operation.
- Remove:
 - Guard [A]
- Visually inspect the joint boots [B].
- ★ If the joint boot is torn, worn, deteriorated, or leaks grease, replace the front axle assembly.

Rear Propeller Shaft Joint Boot Inspection

- Visually inspect the rear propeller shaft joint boot [A] in accordance with the Periodic Maintenance Chart or if the shaft is noisy during operation.
- ★ If the joint boot is torn, worn, or deteriorated, replace the joint boot and check the propeller shaft (see Rear Propeller Shaft Inspection in Final Drive chapter).

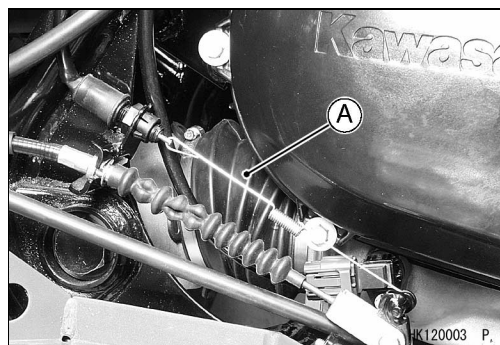
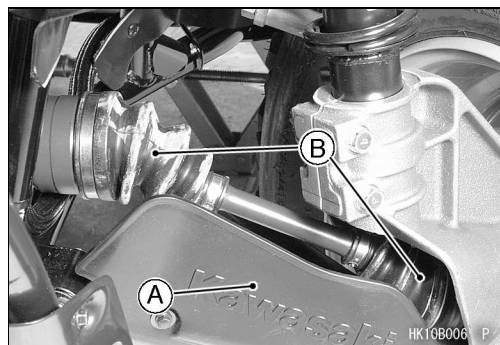
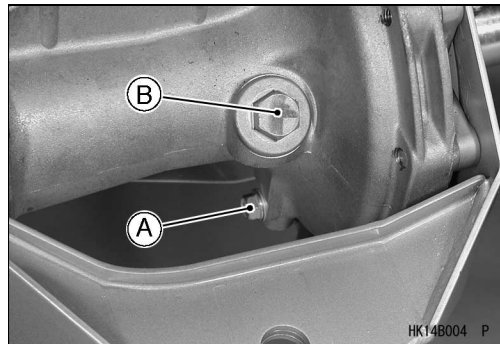

Periodic Maintenance Procedures

Brakes

Front Brake Pad Wear Inspection

- Check the lining thickness [A] of the pads in each caliper.
- ★ If the lining thickness of either pad is less than the service limit [B], replace both pads in the caliper as a set.

Pad Lining Thickness

- Standard:** 4.5 mm (0.18 in.)
- Service Limit:** 1 mm (0.04 in.)

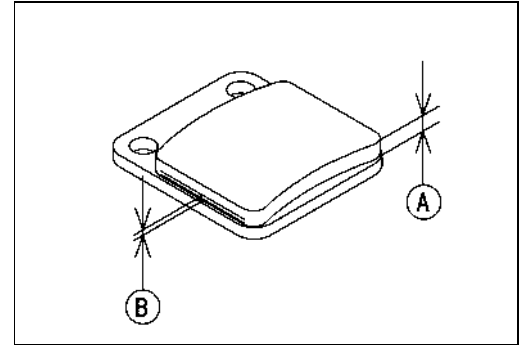

Brake Hose and Connection Check

- Inspect the brake hose and fittings for deterioration, cracks and signs of leakage.
- The high pressure inside the brake line can cause fluid to leak [A] or the hose to burst if the line is not properly maintained. Bend and twist the rubber hose while examining it.
- ★ Replace the hose if any cracks [B] or bulges [C] are noticed.
- Tighten any loose fittings.

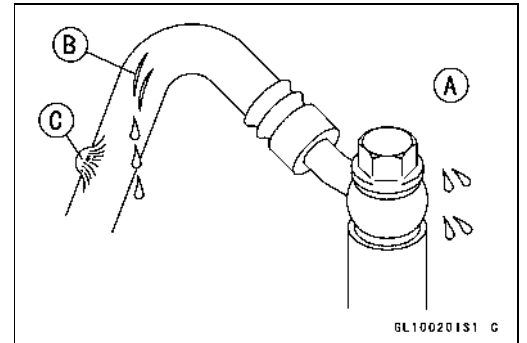

Brake Hose Replacement

- Pump the brake fluid out of the line as explained in the Brake Fluid Change.
- Remove the banjo bolts at both ends of the brake hose, and pull the hose off the vehicle.
- Immediately wipe up any brake fluid that spills.

CAUTION

Brake fluid quickly ruins painted surfaces; any spilled fluid should be completely washed away immediately.

- Use a new flat washer for each side of the hose fittings.
- Install the new brake hose in its place (see Appendix chapter), and tighten the banjo bolts.

Torque - Brake Hose Banjo Bolts: 25 N·m (2.5 kgf·m, 18 ft·lb)

Brake Fluid Level Inspection

- Position the reservoir horizontal, and check that the fluid level in the reservoir is higher than the lower level line [A].
- ★ If the fluid level is lower than the lower level line, check for fluid leakage of the brake line, and add the fluid as follows:

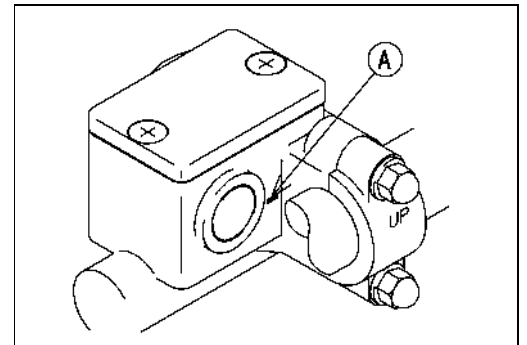

2-22 PERIODIC MAINTENANCE

Periodic Maintenance Procedures

- Remove the reservoir cap, and fill the reservoir to the upper level line [A] in the reservoir with the same type and brand of the fluid that is already in the reservoir. And then install the reservoir cap.

⚠ WARNING

Change the fluid in the brake line completely if the fluid must be refilled but the type and brand of the fluid that is already in the reservoir are unidentified.

- Tighten:
Torque - Reservoir Cap Screws : 1.5 N·m (0.15 kgf·m, 13 in·lb)

Brake Fluid Change

- Remove the front wheels (see Wheels/Tires chapter).
- Remove the reservoir cap and the rubber cap on the bleed valve.
- Attach a clear plastic hose to the bleed valve on the caliper, and run the other end of the hose into a container.
- Fill the reservoir with new brake fluid.
- Change the brake fluid as follows:
 - Open the bleed valve [A].
 - Apply the brake lever and hold it [B].
 - Close the bleed valve [C].
 - Release the brake lever [D].
- Check the fluid level in the reservoir often, replenishing it as necessary.

NOTE

- If the fluid in the reservoir runs completely out any time during fluid changing, air will enter the line, and the system must be bled.

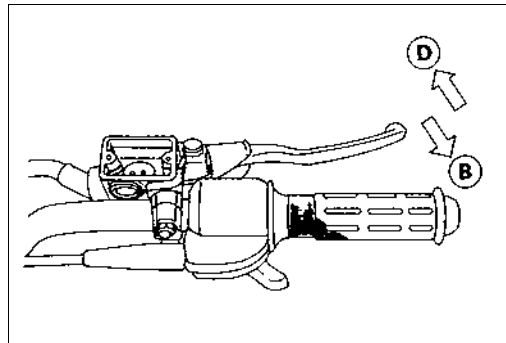
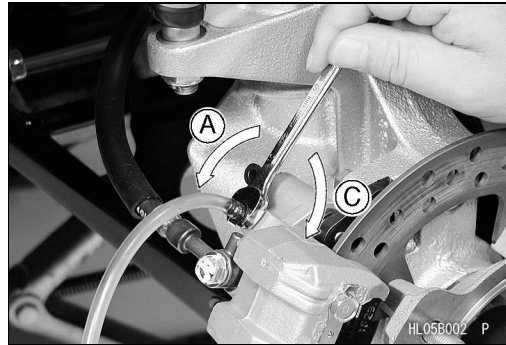
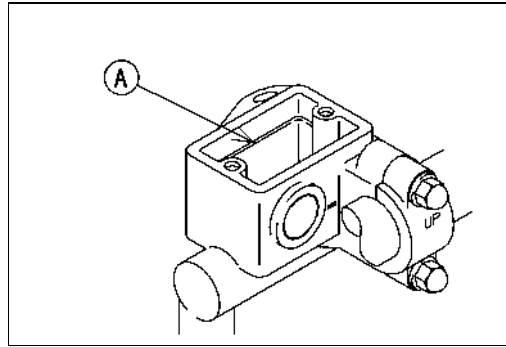

- Repeat this operation until fresh brake fluid comes out into the plastic hose or the color of the fluid changes.

⚠ WARNING

Do not mix two brands of fluid. Change the brake fluid in the brake line completely if the brake fluid must be refilled but the type and brand of the brake fluid that is already in the reservoir are not known.

- Tighten:
Torque - Bleed Valves: 5.9 N·m (0.6 kgf·m, 52 in·lb)
- Install the front wheels (see Wheels/Tires chapter).
- Apply the brake lever forcefully for a few seconds, and check for fluid leakage around the fittings.

⚠ WARNING

If the brake lever has a soft or "spongy feeling" when it is applied, there might be air in the brake line or the brake may be defective. Since it is dangerous to operate the vehicle under such conditions, bleed the air from the brake line immediately.

Brake Master Cylinder Piston Assembly and Dust Seal Replacement

- Refer to Master Cylinder section in Brakes chapter for Brake Master Cylinder Cup and Dust Seal Replacement.

Periodic Maintenance Procedures

Caliper Piston Seal and Dust Seal Replacement

- Refer to Calipers section in Brakes chapter for Caliper Piston Seal and Dust Seal Replacement.

Rear Brake Plates Replacement

- Refer to Internal Wet Brake section in Brakes chapter for Rear Brake Plates Replacement.

Rear Brake Lever Free Play Inspection

- Check the rear brake lever free play [A].
- Pull the rear brake lever lightly until the brake is applied.
- ★ If the play is incorrect, adjust it.

Rear Brake Lever Free Play

Standard: 1 ~ 2 mm (0.04 ~ 0.08 in.)

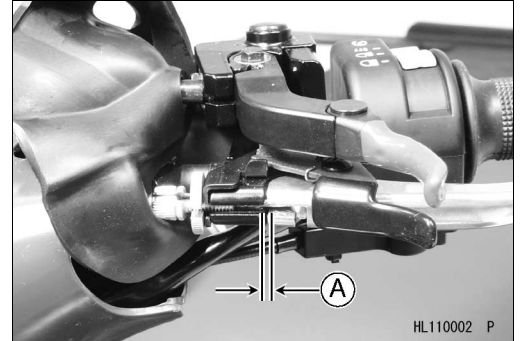

Brake Pedal Free Play Inspection

- Check the brake pedal free play [A].
- Depress the brake pedal lightly by hand until the brake is applied.
- ★ If the free play is incorrect, adjust it.

Brake Pedal Free Play

Standard: 15 ~ 25 mm (0.6 ~ 1.0 in.)

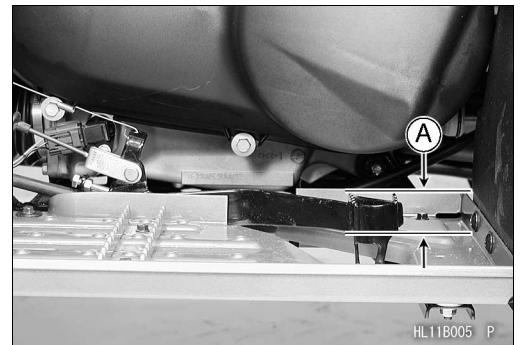

Rear Brake Lever and Pedal Free Play Adjustment

NOTE

- Since the rear brake lever and pedal free play adjustments affect each other, make them at the same time.

Rear Brake Lever:

- Loosen the knurled locknut [A] and turn the adjuster [B] at the rear brake lever in as far as it will go.
- Tighten the locknut.

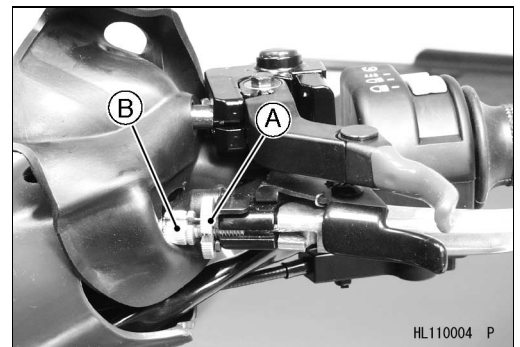

- Turn the brake lever adjuster [A] at the rear end of the brake cable until the rear brake lever has the correct amount of play.

Brake Pedal:

- Turn the brake pedal adjuster [B] at the rear end of the brake cable until the brake pedal has the correct amount of play.

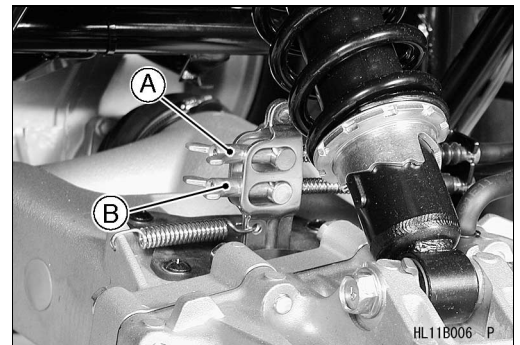

- Operate the pedal a few times to see that it returns to its rest position immediately upon release.
- Rotate the rear wheels to check for brake drag.
- Check braking effectiveness.
- ★ If there is any doubt as to the conditions of the brake, check the brake parts for wear or damage.

2-24 PERIODIC MAINTENANCE

Periodic Maintenance Procedures

Steering

Steering Inspection

- Turn the handlebar left and right, and check the steering action.
- ★ If the steering action is not smooth, or if the steering binds or catches before the stop, lubricate the steering stem bearing.

NOTE

- *The cables and wires will have some effect on the steering action which must be taken into account.*
- Check the steering action again.
- ★ If steering stem bearing lubrication does not remedy the problem, inspect the steering stem for straightness, steering stem clamps, and tie-rod bearings.
- ★ If you feel looseness, or if the steering rattles as it turns, check the tightness of the steering bolts and nuts.
- Tighten loose bolts and nuts to the specified torque (see Exploded View), and check the steering action again.
- ★ If the steering action does not change by tightening the bolts and nuts, inspect the steering stem clamps, steering stem bearings, tie-rod bearings, and steering knuckle joints.

Electrical System

Battery Inspection

- Refer to Battery section in Electrical System chapter for Battery Inspection.

Spark Plug Cleaning / Inspection

- Clean the spark plug, preferably in a sandblasting device, and then clean off any abrasive particles. The plug may also be cleaned using a wire brush or other suitable tool.
- ★ If the spark plug electrodes are corroded or damaged, or if the insulator is cracked, replace the plug. Use the standard spark plug or its equivalent.

Spark Plug Gap Inspection

- Measure the gap [A] with a wire-type thickness gauge.
- ★ If the gap is incorrect, carefully bend the side electrode [B] with a suitable tool to obtain the correct gap.

Spark Plug Gap

0.8 ~ 0.9 mm (0.031 ~ 0.035 in.)

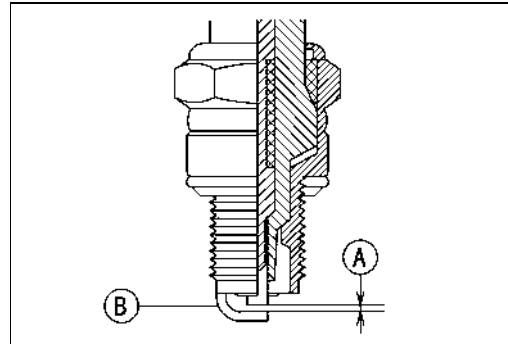

Drive Belt Failure Detection System Inspection

Refer to Drive Belt Failure Detection System section in Electrical System chapter.

Brake Light Switch Adjustment

- Check the operation of the brake light switch by depressing the brake pedal [A]. The brake light should go on after about 10 mm (0.4 in.) of pedal travel [B].

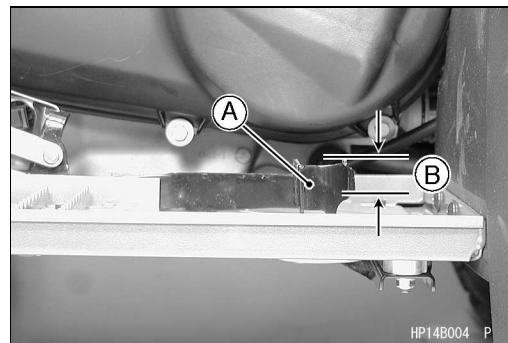

Periodic Maintenance Procedures

★ If it does not, adjust the brake light switch [A] up or down. To change the switch position, turn the adjusting nut [B].

Brake Light Switch Timing

Standard: ON after 10 mm (0.4 in.) of pedal travel

CAUTION

To avoid damaging the electrical connections inside the switch, be sure that the switch body does not turn during adjustment.

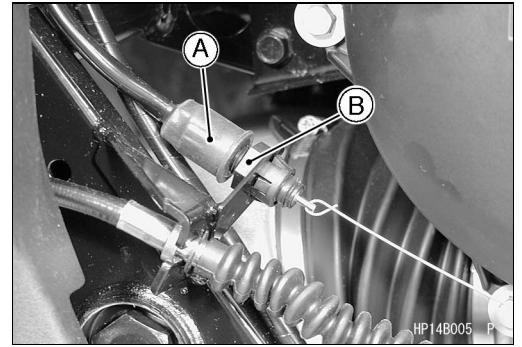

2-26 PERIODIC MAINTENANCE

Periodic Maintenance Procedures

General Lubrication

Lubrication

- Before lubricating each part, clean off any rusty spots with rust remover and wipe off any grease, oil, dirt, or grime.
- Lubricate the points listed below with indicated lubricant.

NOTE

- Whenever the vehicle has been operated under wet or rainy conditions, or especially after using a high-pressure spray water, perform the general lubrication.

Cables: Lubricate with Cable Lubricant

Brake Cables
Throttle Cable
Choke Cable

- Lubricate the cables by seeping the oil between the cable and housing.
- The cable may be lubricated by using a pressure cable luber with an aerosol cable lubricant.

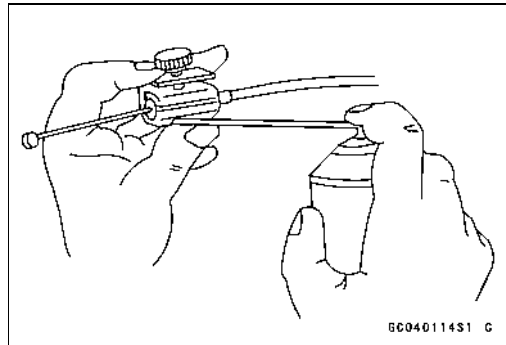

- With the cable disconnected at the both ends, the cable should move freely [A] within the cable housing.
- ★ If cable movement is not free after lubricating, if the cable is frayed, or if the cable housing is kinked, replace the cable.

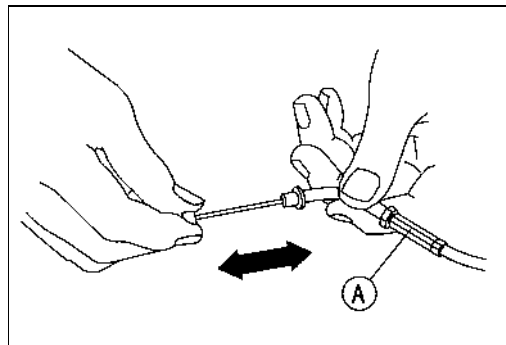

Points: Lubricate with Grease.

Throttle Inner Cable ENds [A]
Choke Cable Lower End
Brake Cable Ends

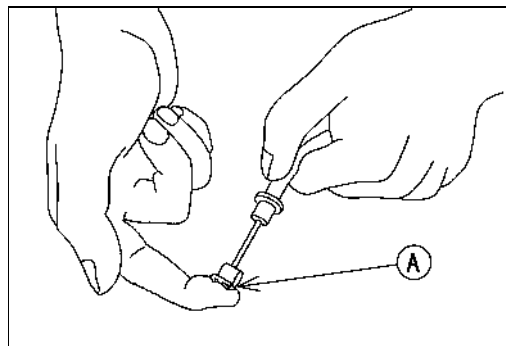

Slide Points: Lubricate with Grease.

Brake Lever
Brake Pedal Pivot Shaft
Throttle Lever Shaft

Periodic Maintenance Procedures

Bolts and Nuts Tightening

Tightness Inspection

- Check the tightness of the bolts and nuts listed here in accordance with the Periodic Maintenance Chart. Also, check to see that each cotter pin is in place and in good condition.
- ★ If there are loose fasteners, retorque them to the specified torque following the specified tightening sequence. Refer to the appropriate chapter for torque specifications. If torque specifications are not listed in the appropriate chapter, see the Basic Torque Table (see Torque and Locking Agent). For each fastener, first loosen it by 1/2 turn, then tighten it.
- ★ If cotter pins are damaged, replace them with new ones.

Bolts, Nuts, and Fasteners to be checked

Wheels:

- Front Axle Nuts and Cotter Pins
- Rear Axle Nuts and Cotter Pins
- Wheel Nuts

Brakes:

- Master Cylinder Clamp Bolts
- Brake Lever Pivot Bolt
- Brake Lever Pivot Nut
- Caliper Mounting Bolts
- Brake Pedal Cotter Pin

Steering/Suspension:

- Handlebar Clamp Bolts
- Stem Clamp Allen Bolts
- Stem Bearing Housing Bolts
- Tie-Rod End Nuts and Cotter Pins
- Tie-Rod Adjusting Sleeve Locknuts
- Shock Absorber Mounting Bolts and Nuts
- Suspension Arm Pivot Bolts
- Steering Knuckle Pivots Nuts and Cotter Pins

Engine:

- Engine Mounting Bolts
- Engine Mounting Bracket Bolts
- Exhaust Pipe Holder Nuts
- Muffler Mounting Bolts
- Muffler Clamp Bolt

Front Final Drive:

- Gear Case Bracket Bolts

Others:

- Footrest Mounting Bolts
- Throttle Mounting Bolts
- Carrier Mounting Bolts

Fuel System

Table of Contents

Exploded View.....	3-2	Carburetor Installation.....	3-13
Specifications.....	3-6	Carburetor Disassembly.....	3-14
Throttle Lever and Cable.....	3-7	Carburetor Assembly.....	3-15
Throttle Lever Free Play Inspection.....	3-7	Carburetor Cleaning.....	3-16
Throttle Lever Free Play Adjustment.....	3-7	Carburetor Inspection.....	3-17
Throttle Case Removal/Disassembly.....	3-7	Air Cleaner.....	3-19
Throttle Case Assembly/Installation.....	3-7	Air Cleaner Element Removal.....	3-19
Throttle Cable Installation.....	3-8	Air Cleaner Element Installation.....	3-19
Throttle Case Inspection.....	3-8	Air Cleaner Element Cleaning and Inspection..	3-20
Throttle Cable Lubrication.....	3-8	Air Cleaner Draining.....	3-20
Throttle Cable Inspection.....	3-8	Air Cleaner Housing Removal.....	3-20
Choke Lever and Cable.....	3-9	Air Cleaner Housing Installation.....	3-21
Choke Lever and Cable Removal.....	3-9	Snorkel Duct Removal.....	3-21
Choke Lever and Cable Installation.....	3-10	Fuel Tank.....	3-22
Choke Cable Lubrication.....	3-10	Fuel Tank Removal.....	3-22
Choke Cable Inspection.....	3-10	Fuel Tank Installation.....	3-22
Carburetor.....	3-11	Fuel Tap Removal.....	3-23
Idle Speed Inspection.....	3-11	Fuel Tap Installation.....	3-23
Idle Speed Adjustment.....	3-11	Fuel Tank and Fuel Tap Cleaning.....	3-23
Pilot Screw Adjustment.....	3-11	Fuel Tap Inspection.....	3-23
Service Fuel Level Inspection.....	3-11	Fuel Level Gauge Removal.....	3-24
Fuel Level Adjustment.....	3-12	Fuel Level Gauge Installation.....	3-24
Fuel System Cleanliness Inspection.....	3-12	Fuel Level Gauge Check.....	3-24
Carburetor Removal.....	3-13		

3-2 FUEL SYSTEM

Exploded View

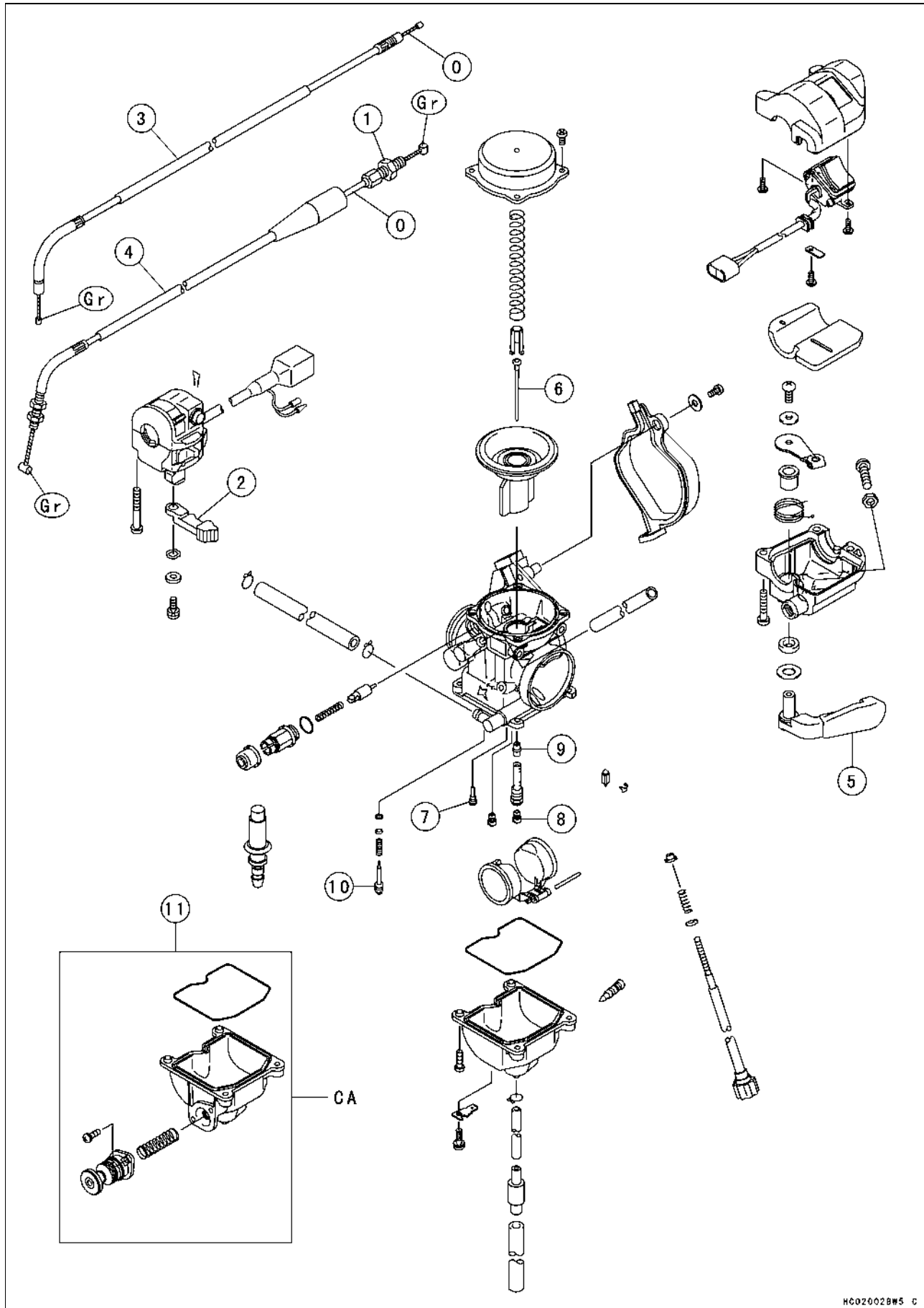

Exploded View

No.	Fastener	Torque			Remarks
		N·m	kgf·m	ft·lb	
1	Throttle Cable Locknut	1.3	0.13	11 in·lb	

- 2: Choke lever
- 3: Choke cable
- 4: Throttle cable
- 5: Throttle lever
- 6: Jet needle
- 7: Pilot jet
- 8: Main jet
- 9: Needle jet
- 10: Pilot screw
- 11: Priming pump

O: Apply engine oil.
 Gr: Apply grease.
 CA: Canada model

3-4 FUEL SYSTEM

Exploded View

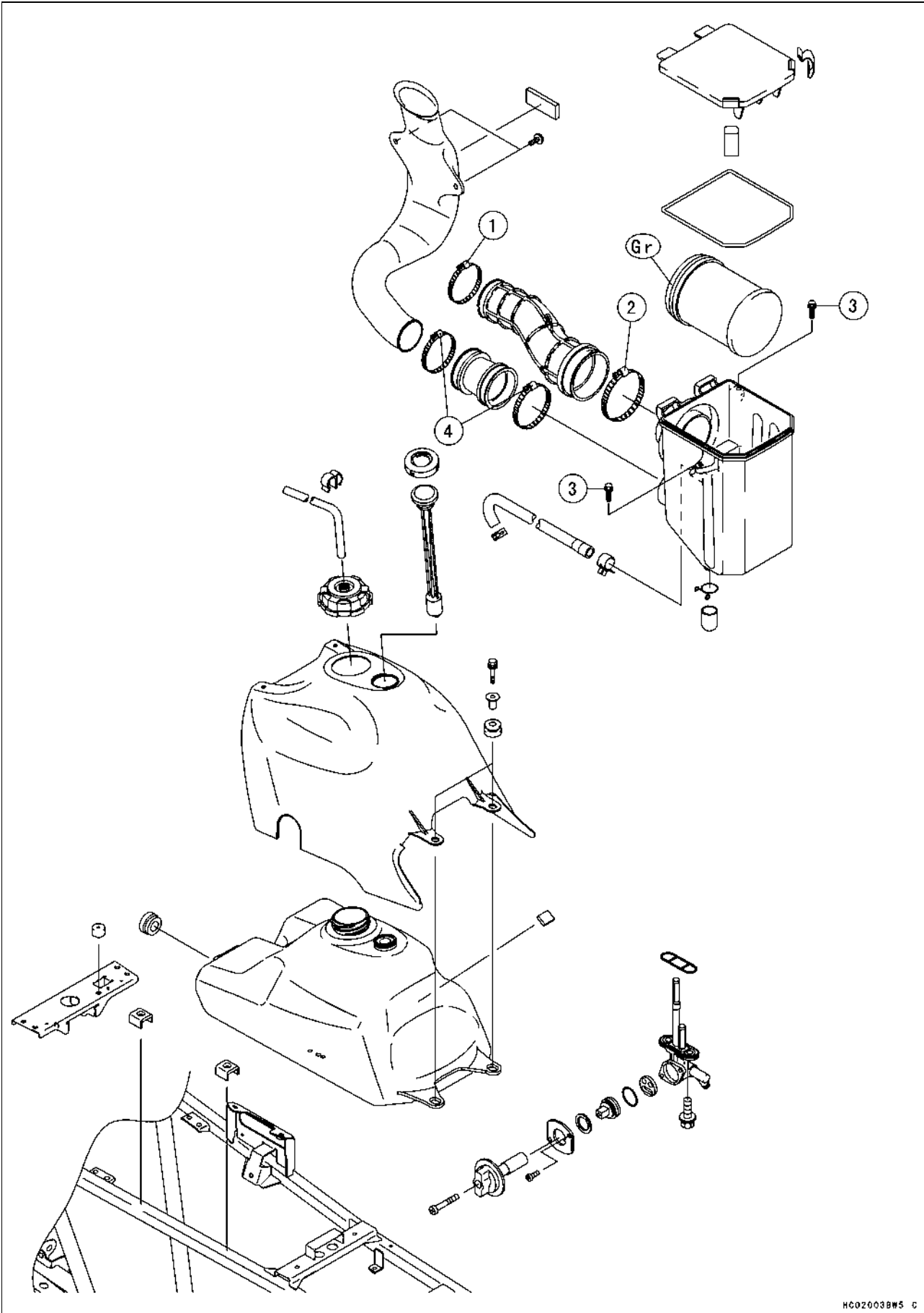

Exploded View

No.	Fastener	Torque			Remarks
		N·m	kgf·m	ft·lb	
1	Air Cleaner Duct Front Clamp Screw	1.4	0.14	12 in·lb	
2	Air Cleaner Duct Rear Clamp Screw	4	0.41	36 in·lb	
3	Air Cleaner Housing Mounting Bolts	6.9	0.7	61 in·lb	
4	Air Cleaner Intake Duct Clamp Screws	1.4	0.14	12 in·lb	

Gr: Apply grease.

3-6 FUEL SYSTEM

Specifications

Item	Standard	Service Limit
Throttle Case and Cable:		
Throttle lever free play	2 ~ 3 mm (0.08 ~ 0.12 in.)	---
Carburetor:		
Make/Type	KEIHIN, CVK34	---
Main jet	#155	---
Main air jet:	#70	---
Needle jet:	#6	---
Jet needle	N2LQ	---
Pilot jet	#35	---
Pilot air jet	#150	---
Pilot screw	1 1/2 turns out	---
Starter jet	#90	---
Idle speed	1300 ± 50 r/min (rpm)	---
Service fuel level	0.5 ± 1 mm (0.02 ± 0.04 in.) above bottom edge of carburetor body	---
Float height	17.0 ± 2 mm (0.67 ± 0.08 in.)	---
Optional parts:		
Main jet:		
*Altitude:		
0 ~ 500 m (0 ~ 1700 ft)	#155 (92063-1332) or #158 (92063-1344)	---
500 ~ 1400 m (1700 ~ 4700 ft)	#155 (92063-1332)	---
1400 ~ 2300 m (4700 ~ 7700 ft)	#145 (92063-1017)	---
2300 ~ 3300 m (7700 ~ 10700 ft)	#135 (92063-1014)	---
3300 ~ 4500 m (10700 ~ 14800 ft)	#125 (92063-1069)	---
Air Cleaner:		
Air cleaner element oil	High-quality foam air filter oil	---

*: Refer to pg. 5–23 for high altitude setting in Converter System chapter.

Special Tools - Fuel Level Gauge: 57001–1017

Carburetor Drain Plug Wrench, Hex 3: 57001–1269

Pilot Screw Adjuster, A: 57001–1239

Throttle Lever and Cable

Throttle Lever Free Play Inspection

- Refer to Throttle Lever Free Play Inspection in Periodic Maintenance chapter.

Throttle Lever Free Play Adjustment

- Refer to Throttle Lever Free Play Adjustment in Periodic Maintenance chapter.

Throttle Case Removal/Disassembly

- Remove the throttle case screws [A] and pull the case open.
- Slide the cable adjuster dust cover out of place.

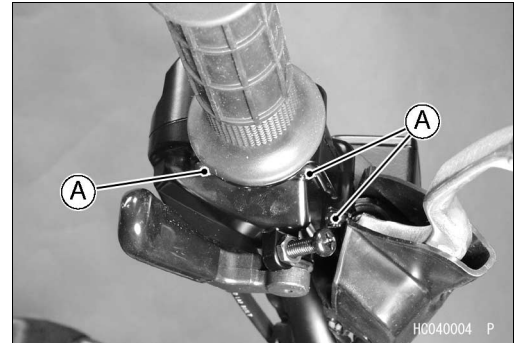

- Remove the rubber cover [A].

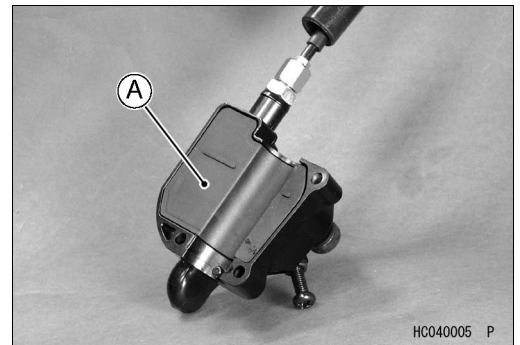

- Pull the cable tip [A] out of the throttle lever catch with the throttle lever opened.
- Loosen the locknut [B] and unscrew the adjuster [C].
- Disassemble the throttle case as follows:
 - Remove the throttle lever screw [D], lockwasher, and flat washer, and lift the throttle lever [E] and return spring from the case.
 - Pull the throttle control lever [F] out of the case.

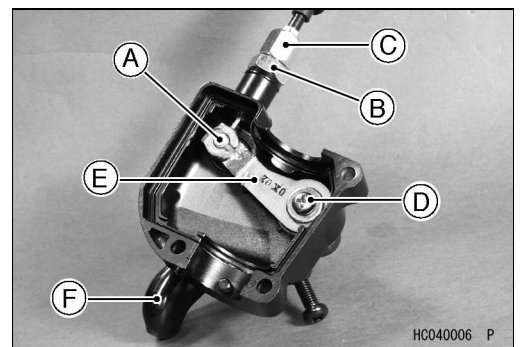

Throttle Case Assembly/Installation

- Lubricate the throttle case and cable before assembly/installation.
- Be certain that the return spring is correctly installed on the throttle lever [A].

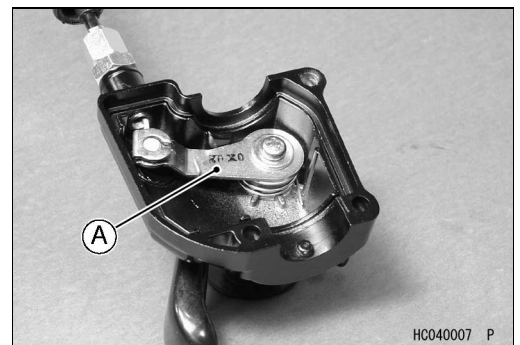

3-8 FUEL SYSTEM

Throttle Lever and Cable

- Swing the throttle control lever so that the carburetor throttle valve is fully open. Turn the throttle limiter screw [A] until it is spaced about 1 mm (0.04 in.) [B] away from the throttle lever stop [C]. Tighten the locknut [D].

NOTE

- Refer to the Owner's Manual for the function of the throttle limiter and adjustment procedure of it.

WARNING

Operation with an improperly assembled throttle case could result in an unsafe riding condition.

- Check the throttle lever free play (see Throttle Lever Free Play Inspection in Periodic Maintenance chapter).

Throttle Cable Installation

- Lubricate the throttle cable before installation.
- Route the cable correctly according to Appendix chapter.

WARNING

Operation with an improperly adjusted, incorrectly routed, or damaged cable could result in an unsafe riding condition.

- Check the throttle cable (see Throttle Lever Free Play Inspection in Periodic Maintenance chapter).

Throttle Case Inspection

- With the throttle cable disconnected from the throttle lever, the lever should move freely and return smoothly by spring.
- ★ If the lever is heavy, disassemble the throttle case, clean and lubricate the throttle case.
- Examine the lever and case for cracks. Replace the case assembly if it is cracked.

Throttle Cable Lubrication

Whenever the throttle cable is removed, lubricate the cable as follows:

- Apply a small amount of multi-purpose grease to the cable both ends.
- Lubricate the cable with a penetrating rust inhibitor through the pressure cable luber.

Throttle Cable Inspection

- With the throttle cable disconnected at both ends, the cable should move freely within the cable housing.
- ★ If the cable does not move freely after lubricating, if the cable is frayed, or if the housing is kinked, replace the cable.

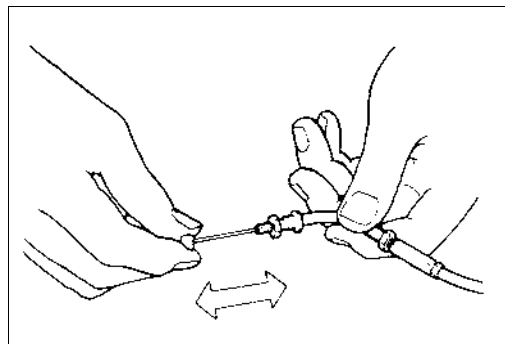
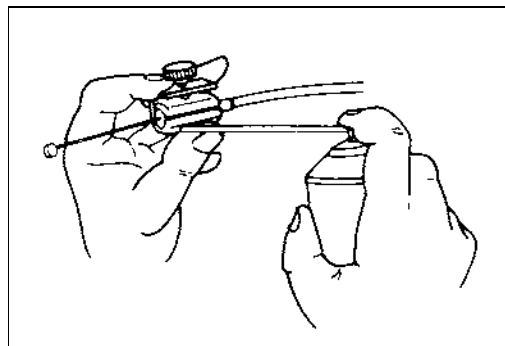
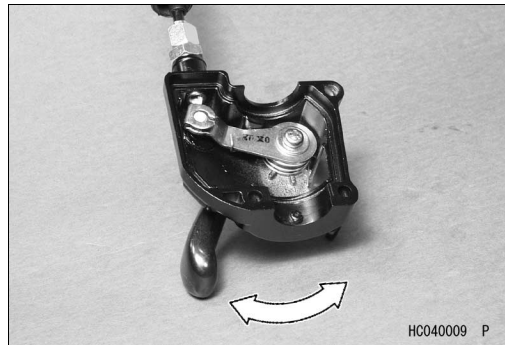
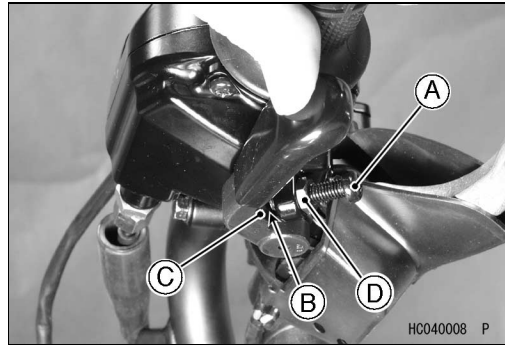

Choke Lever and Cable

Choke Lever and Cable Removal

- Remove the fuel tank (see Fuel Tank Removal).
- Remove the carburetor from the carburetor holder.
- Slide the dust cover [A] out of place.
- Unscrew the starter plunger cap [B] and pull out the starter plunger.

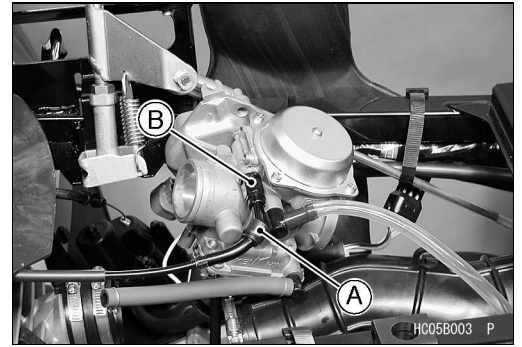

- Hold the starter plunger spring compressed, and free the choke cable lower end [A] from the plunger [B].

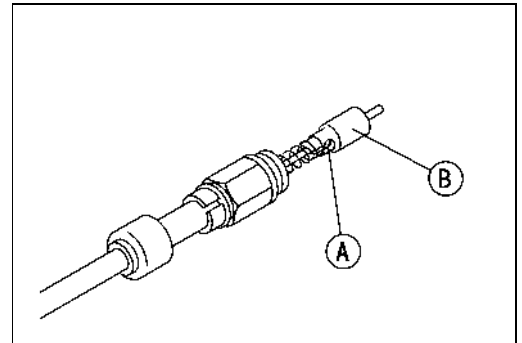

- Remove:
Choke Lever Mounting Screw [A], Plane Washer, and Wave Washer
Switch Case Mounting Screws [B]

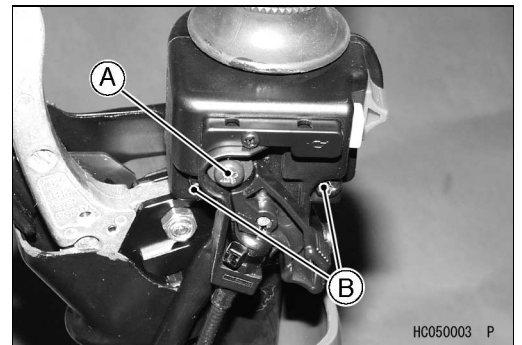

- Free the choke cable upper end [A] from the choke lever [B].

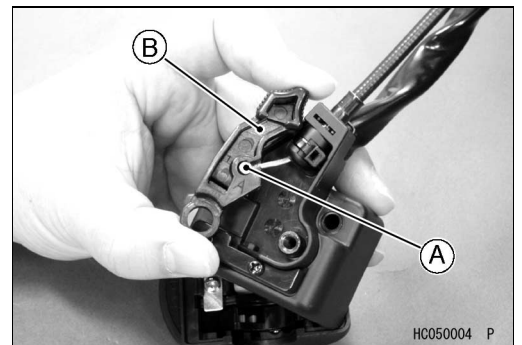

- Pull off the retaining clip [A].

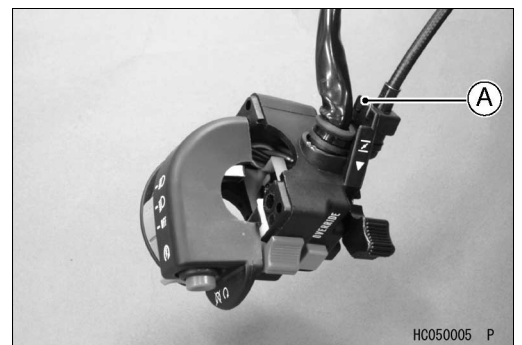

3-10 FUEL SYSTEM

Choke Lever and Cable

- Fit the cable end [A] in the grommet [B], and free the cable from the switch case.
- Pull the cable out of the vehicle.

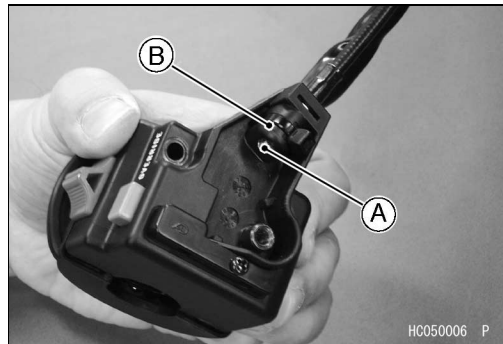

Choke Lever and Cable Installation

- Lubricate the choke cable before installation.
- Install the wave washer, plain washer and screw in that order.
- Route the choke cable according to Appendix chapter.

⚠ WARNING

Operation with an incorrectly routed, or damaged cable could result in an unsafe riding condition.

Choke Cable Lubrication

Whenever the choke cable is removed, lubricate the cable as follows:

- Lubricate the cable with a penetrating rust inhibitor through the pressure cable luber.

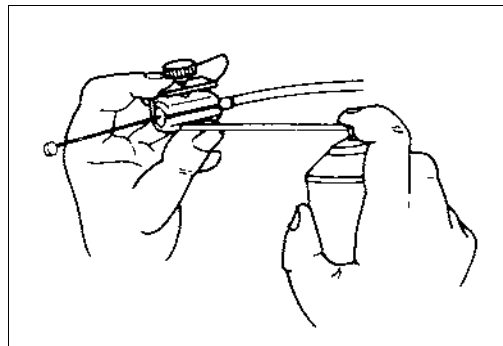

Choke Cable Inspection

- With the choke cable disconnected at both ends, the cable should move freely in the cable housing.
- ★ If the cable does not move freely after lubricating, if the cable is frayed, or if the housing is kinked, replace the cable.

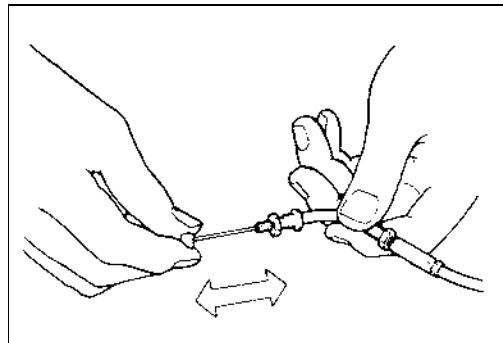

Carburetor

Idle Speed Inspection

- Start the engine and warm it up thoroughly.
- With the engine idling, turn the handlebar to both sides to check for any changes in the idle speed.
- ★ If handlebar movement changes the idle speed, the throttle cable may be improperly adjusted incorrectly routed, or damaged. Be sure to correct any of these conditions before riding.

WARNING

Operation with improperly adjusted, incorrectly routed, or damaged cables could result in an unsafe riding condition.

- Check idle speed with a suitable tachometer.
- ★ If the idle speed is out of the specified range, adjust it.

Idle Speed

Standard: 1,300 ± 50 r/min (rpm)

Idle Speed Adjustment

- Start the engine and warm it up thoroughly.
- Turn the idle adjusting screw [A] until the idle speed is correct.
- Open and close the throttle a few times to make sure that the idle speed is within the specified range.

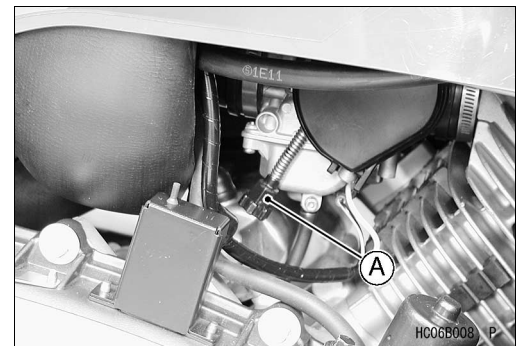

Pilot Screw Adjustment

- Adjust the pilot screw if necessary.
- Turn the carburetor pilot screw [A] all the way in until it seats lightly.

Special Tool - Pilot Screw Adjuster, A: 57001-1239 [B]

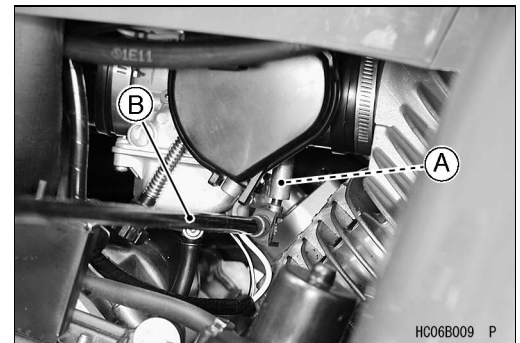

CAUTION

Do not overtighten the pilot screw or the carburetor body will be damaged and require replacement.

- Back the pilot screw out the specified number of turns.

Carburetor Pilot Screw Setting

Standard: 1 1/2 turns out

Service Fuel Level Inspection

WARNING

Gasoline is extremely flammable and can be explosive under certain conditions. Turn the ignition switch OFF. Do not smoke. Make sure the area is well ventilated and free from any source of flame or sparks; this includes any appliance with a pilot light.

- Park the vehicle on a level surface.
- Remove the fuel tank cover.
- Remove the check valve [A] at the end of the carburetor overflow hose.

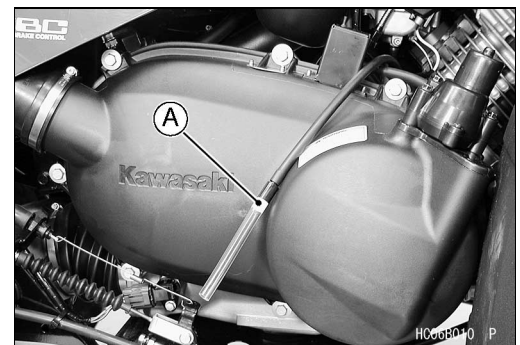

3-12 FUEL SYSTEM

Carburetor

- Connect the fuel level gauge to the open end of the carburetor overflow hose.

Special Tool - Fuel Level Gauge: 57001-1017

Fuel Level Gauge [A]
Zero Line [B]
Drain Plug [C]
Carburetor Body Bottom Edge [D]
Fuel Level [E]

- Hold the gauge vertically against the side of the carburetor body so that the "zero" line is several millimeters higher than the bottom edge of the carburetor body.
- Turn the fuel tap to the ON position to feed fuel to the carburetor and gauge, then turn out the carburetor drain plug a few turns.

Special Tool - Carburetor Drain Plug Wrench, Hex 3: 57001-1269

- Wait until the fuel level in the gauge settles.
- Keeping the gauge vertical, slowly lower the gauge until the "zero" line is even with the bottom edge of the carburetor body.

NOTE

- Do not lower the "zero" line below the bottom edge of the carburetor body. If the gauge is lowered and then raised it again, the fuel level measured shows somewhat higher than the actual fuel level. If the gauge is lowered too far, dump the fuel out of it into a suitable container and start the procedure over again.

- Read the fuel level in the gauge and compare it to the specification.
- Tighten the drain plug and remove the fuel level gauge.
- ★ If the fuel level is incorrect, adjust it.

Fuel Level

Standard: $0.5 \pm 1 \text{ mm}$ ($0.02 \pm 0.04 \text{ in.}$) above the bottom edge of the carburetor body

Fuel Level Adjustment

- Remove the carburetor.
- Drain the carburetor.
- Remove the float (see Carburetor Disassembly).
- Bend the tang [A] on the float arm very slightly to change the float height. Increasing the float height lowers the fuel level and decreasing the float height raises the fuel level.

Float Height

Standard: $17.0 \pm 2 \text{ mm}$ ($0.67 \pm 0.08 \text{ in.}$)

Float Bowl Mating Surface [A]
Float Valve Needle Rod (contacted but unloaded) [B]
Float [C]
Float Height [D]

- ★ If the fuel level cannot be adjusted by this method, the float or the float valve is damaged.
- Assemble the carburetor, install it on the vehicle, and recheck the fuel level.

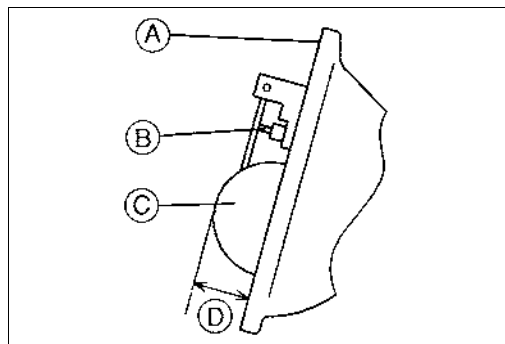
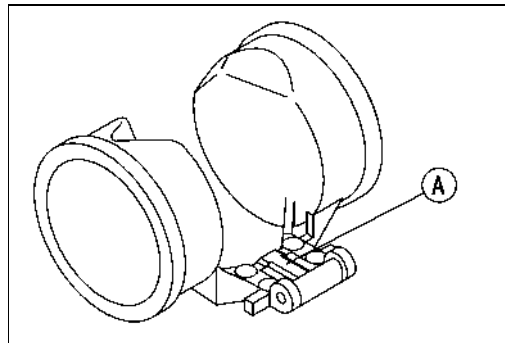
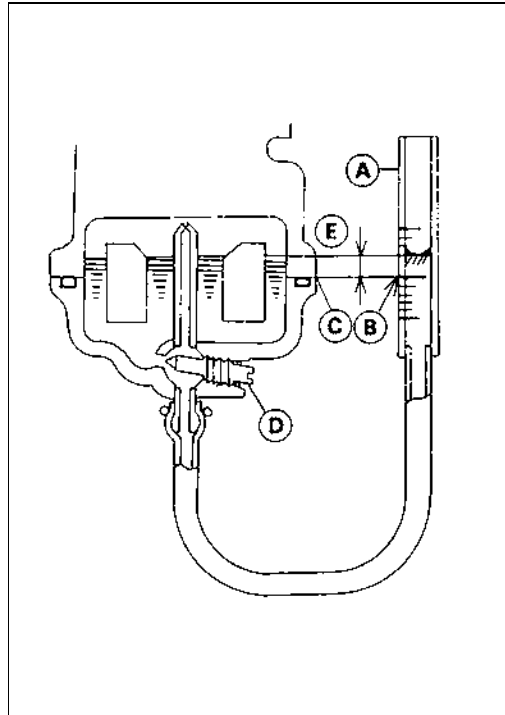

Fuel System Cleanliness Inspection

- Refer to Fuel System Cleanliness Inspection in Periodic Maintenance chapter.

Carburetor

Carburetor Removal

⚠ WARNING

Gasoline is extremely flammable and can be explosive under certain conditions. Turn the ignition switch OFF. Do not smoke. Make sure the area is well ventilated and free from any source of flame or sparks; this includes any appliance with a pilot light.

- Remove:
 - Fuel Tank (see Fuel Tank Removal)
 - Screw [A] and Washer
 - Throttle Cable Pulley Cover [B]
 - Throttle Cable Lower End [C]
 - Carburetor Heater Lead and Ground Lead Connectors
- Loosen the clamp screws [A] on the carburetor holder and air cleaner duct.
- Remove the choke cable lower end [B].

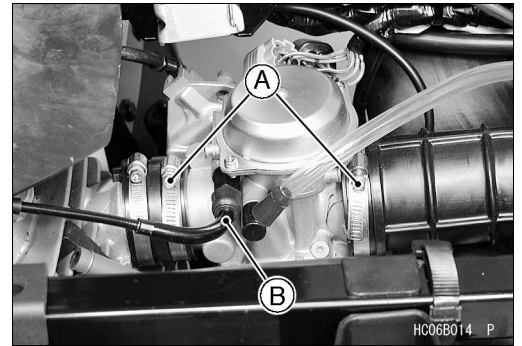
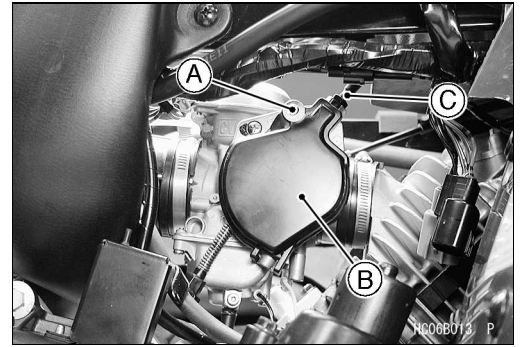

Carburetor Installation

- Adjust the pilot screw before installation.
- Align the carburetor holder notch [A] with the carburetor projection [B].

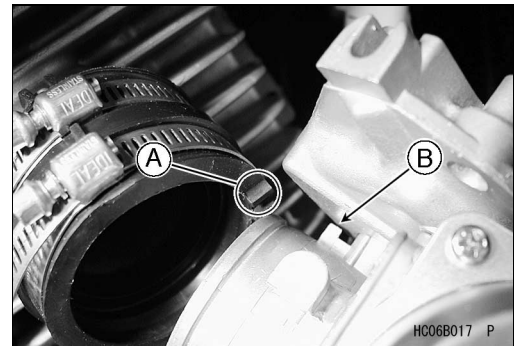

- Align the air cleaner duct notches [A] with the carburetor projections [B].

Torque - Air Cleaner Duct Front Clamp Screws: 1.4 N·m (0.14 kgf·m, 12 in·lb)

- Route the carburetor vent tube according to Appendix chapter.
- Check fuel leakage from the carburetor.

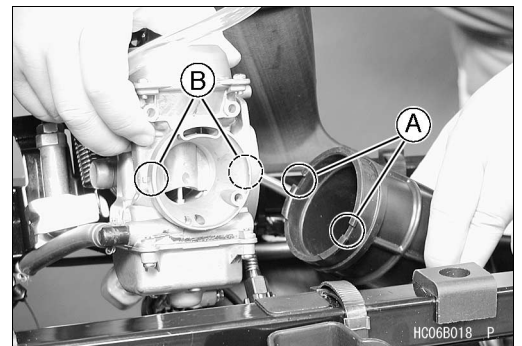

⚠ WARNING

Fuel Spilled from the carburetor is hazardous.

- ★ If the carburetor has been disassembled, or if there is some other reason that the fuel level may be incorrect, inspect the fuel level (see Carburetor Fuel Level Inspection).

3-14 FUEL SYSTEM

Carburetor

- Connect the carburetor heater lead [A] and ground lead [B] connectors.
- Route the carburetor hoses according to Cable, Wire, and Hose Routing section in Appendix chapter.
- Adjust the idle speed (see Idle Speed Adjustment).
- Check the throttle cable (see Throttle Lever Free Play Inspection in Periodic Maintenance chapter).

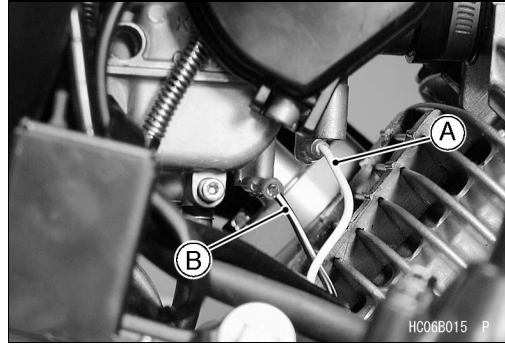

Carburetor Disassembly

- Remove the carburetor (see Carburetor Removal).
- Disassemble the carburetor top end as follows:
 - Remove the upper chamber cover screws and take off the cover [A] and spring [B].
 - Pull out the vacuum piston [C] with the diaphragm.

CAUTION

During carburetor disassembly, be careful not to damage the diaphragm. Never use a sharp edge to remove the diaphragm.

- Slide the jet needle [D] out of the vacuum piston from the bottom. It will come out with a spring seat [E].

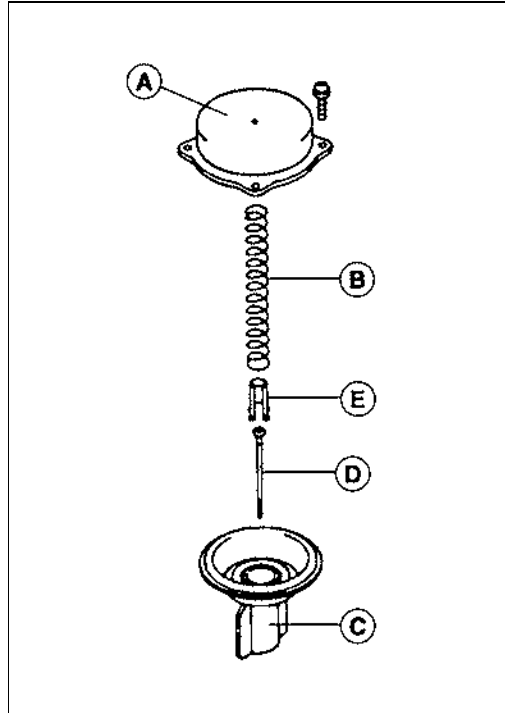

- Unscrew the pilot screw [A] and remove it with its spring, washer, and O-ring.
- Disassemble the carburetor bottom end as follows:
 - Remove:
 - Screws [B]
 - Float Bowl [C]

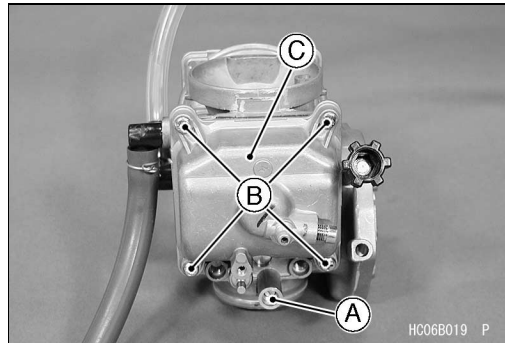

- Slide out the float pivot pin [A], remove the float [B], and drop out the float valve needle with its hanger.

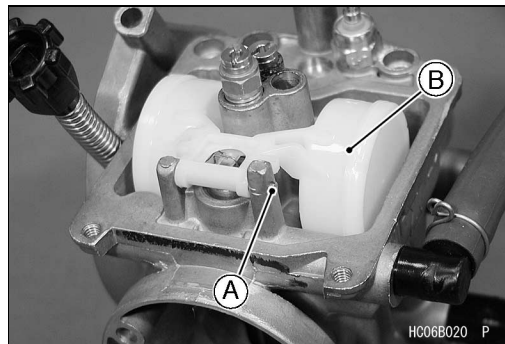

Carburetor

- Remove:
 - Main Jet [A]
 - Air Bleed Pipe [B]
 - Starter Jet [C]
 - Pilot Jet [D]
 - Carburetor Heater [E]

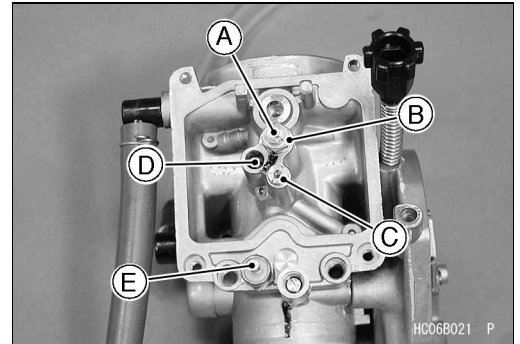

- Push the needle jet [A] out from the inside of the carburetor with your finger.

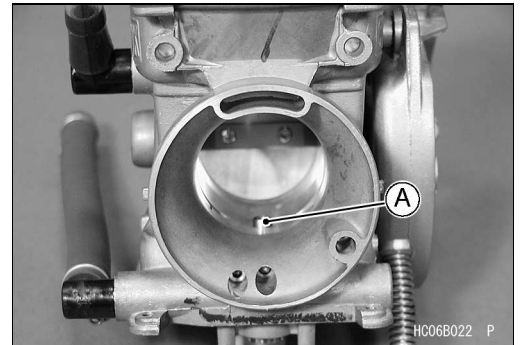

Carburetor Assembly

- Turn the carburetor body upside down, and drop the needle jet [A] into place so that the smaller diameter end [B] of the jet goes in first.
- Carefully screw in the air bleed pipe [C]. It will seat against the needle jet, pushing the end of the jet into the carburetor bore.

CAUTION

Do not force the air bleed pipe or overtighten it. The needle jet or the carburetor body could be damaged requiring replacement.

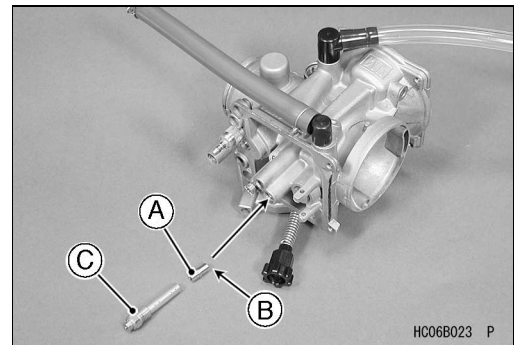

- Apply temperature conductive grease:
 - Carburetor Heater [A]

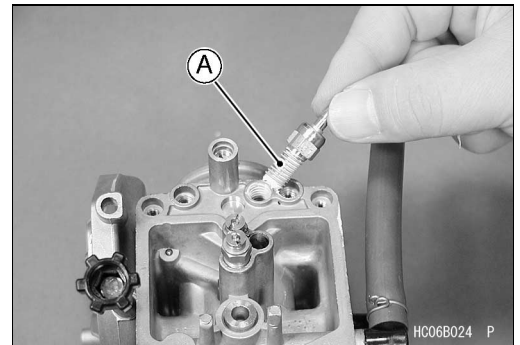

- Drop the float valve needle [A] into the valve seat and hold the float in place with the tang hooked into the needle hanger [B].
- Slip the float pivot pin through the pivot posts and the float as shown.

WARNING

If the float is improperly installed, the specified fuel level cannot be maintained. Fuel spilled from the carburetor is hazardous.

- Set the float height as specified.

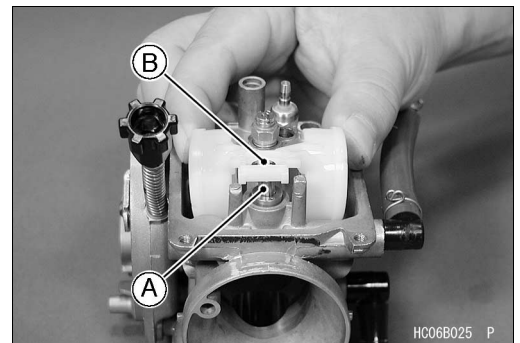

3-16 FUEL SYSTEM

Carburetor

- Insert the jet needle [A] into the hole in the center of the vacuum piston [B], and place the spring seat [C] over the needle.

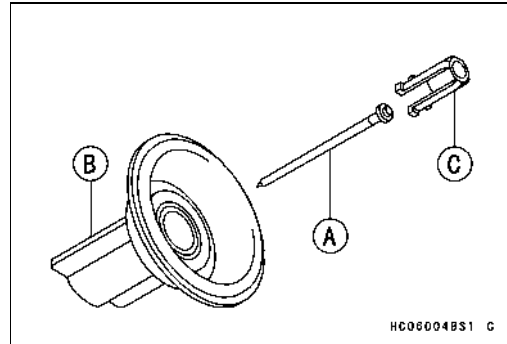

- Slip the needle through the hole in the center of the vacuum piston, and put the spring seat [A] on the top of the needle. Turn the seat so that it does not block the hole [B] at the bottom of the vacuum piston.
- After installing the upper chamber cover, check that the vacuum piston slides up and down smoothly without binding in the carburetor bore.

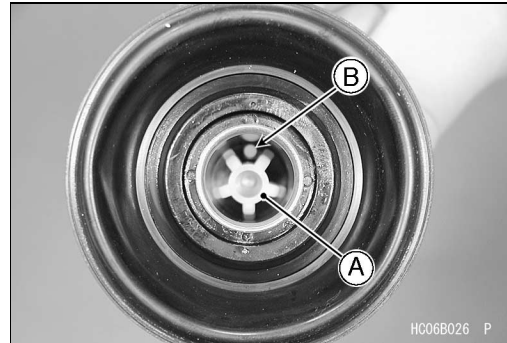

Carburetor Cleaning

⚠ WARNING

Clean the carburetor in a well-ventilated area, and take care that there is no spark or flame anywhere near the working area; this includes any appliance with a pilot light. Because of the danger of highly flammable liquids, do not use gasoline or low-flash point solvents to clean the carburetor. A fire or explosion could result.

CAUTION

Do not use compressed air on an assembled carburetor, the float may be crushed by the pressure, and the vacuum piston diaphragm may be damaged.

Remove as many rubber or plastic parts from the carburetor as possible before cleaning the carburetor with a cleaning solution. This will prevent damage or deterioration of the parts.

The carburetor body has plastic parts that cannot be removed. Do not use a strong carburetor cleaning solution which could attack these parts, instead, use a mild high-flash point cleaning solution safe for plastic parts.

Do not use wire or any other hard instrument to clean carburetor parts, especially jets, as they may be damaged.

- Disassemble the carburetor (see Carburetor Disassembly).
- Immerse all the metal parts in a carburetor cleaning solution.
- Rinse the parts in water.
- When the parts are clean, dry them with compressed air.
- Blow the air and fuel passages with compressed air.
- Assemble the carburetor (see Carburetor Assembly).

Carburetor

Carburetor Inspection

⚠ WARNING

Gasoline is extremely flammable and can be explosive under certain conditions. Turn the ignition switch OFF. Do not smoke. Make sure the area is well ventilated and free from any source of flame or sparks; this includes any appliance with a pilot light.

- Before disassembling the carburetor, check the fuel level (see Service Fuel Level Inspection).
- ★ If the fuel level is incorrect, inspect the rest of the carburetor before correcting it.
- Remove the carburetor (see Carburetor Removal).
- Turn the throttle cable pulley [A] to check that the throttle butterfly valve [B] moves smoothly and return back with the spring tension.
- ★ If the throttle valve does not move smoothly, replace the carburetor.

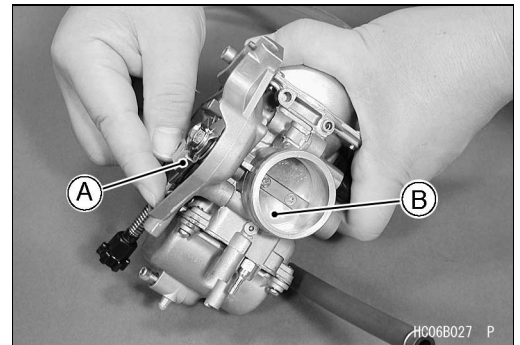

- Disassemble the carburetor (see Carburetor Disassembly).
- Clean the carburetor (see Carburetor Cleaning).
- Check the vacuum piston diaphragm [A], and the O-rings [B] on the float bowl, pilot screw, and starter plunger cap.
- ★ If any of the diaphragm or O-rings are not in good condition, replace them.

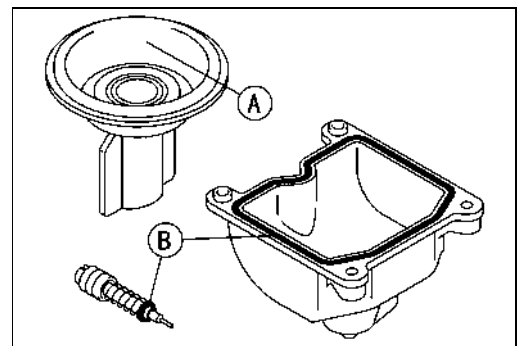

- Check the plastic tip [A] of the float valve needle. It should be smooth, without any grooves, scratches, or tears.
- ★ If the plastic tip is damaged [B], replace the float valve [C].
- Push the rod [D] in the other end of the float valve needle and then release it.
- ★ If it does not spring out, replace the float valve.

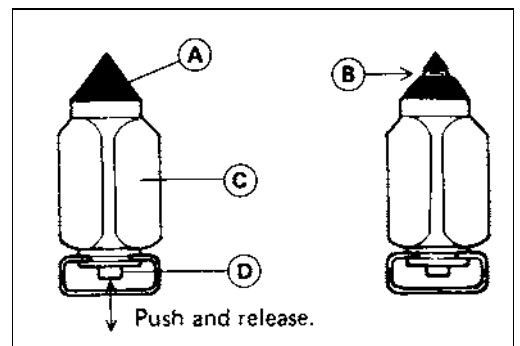

- Check the tapered portion [A] of the pilot screw for wear or damage.
- ★ If the pilot screw is worn or damaged on the tapered portion, it will prevent the engine from idling smoothly. Replace it.

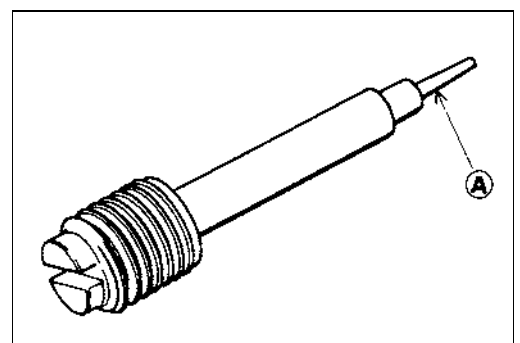

3-18 FUEL SYSTEM

Carburetor

- Check that the vacuum piston moves smoothly in the carburetor body.
The surface of the piston must not be excessively worn.
- ★ If the vacuum piston does not move smoothly, or if it is very loose in the carburetor body, replace both the body and the vacuum piston.

Air Cleaner

Air Cleaner Element Removal

- Remove:
 - Seat (see Frame chapter)
 - Snaps [A]
 - Air Cleaner Cover [B]

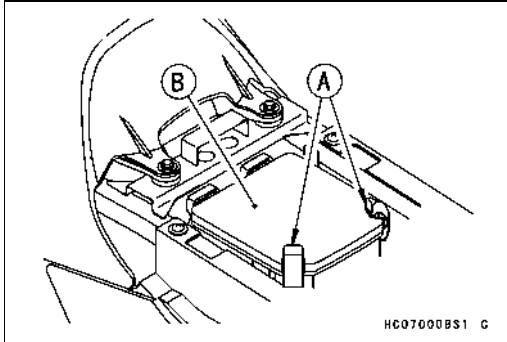

- Pull the rear end [A] of the air cleaner element assembly [B] to the upper and rear, and take it out of the air cleaner housing [C].
- After removing the element, stuff pieces of lint-free, clean cloth into the air cleaner duct to keep dirt out of the carburetor and engine.

⚠ WARNING
 If dirt or dust is allowed to pass through into the carburetor, the throttle may become stuck, possibly causing an accident.

CAUTION
 If dirt gets through into the engine, excessive engine wear and possibly engine damage will occur.

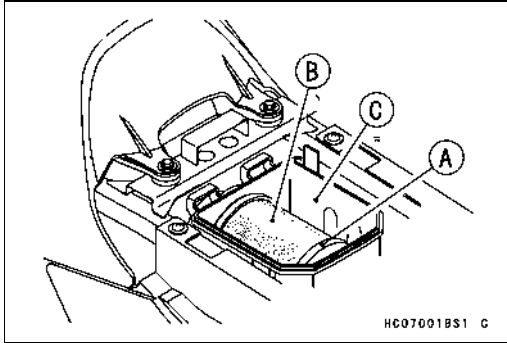

- Remove:
 - Stopper [A]
 - Element [B]

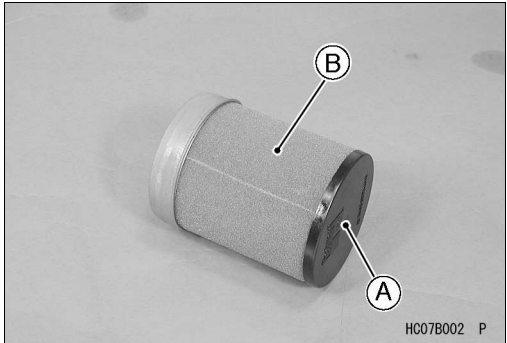

Air Cleaner Element Installation

- Apply grease:
 - Outside of Blue Urethane [A]
 - Inside of Grommet [B]

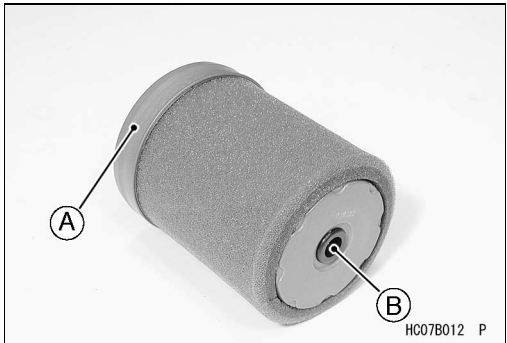

- Install the following parts on the metal net [A].
 - Element [B]
 - Stopper [C]

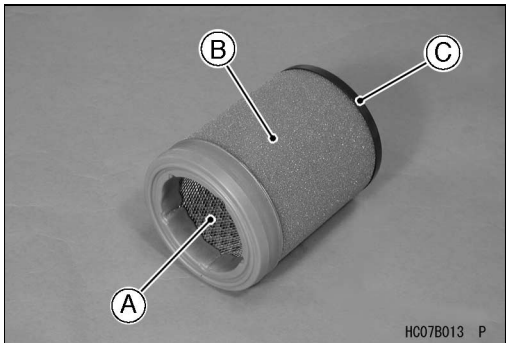

3-20 FUEL SYSTEM

Air Cleaner

- Insert the blue urethane [A] into the air cleaner housing and push the stopper [B] until it is bottomed.

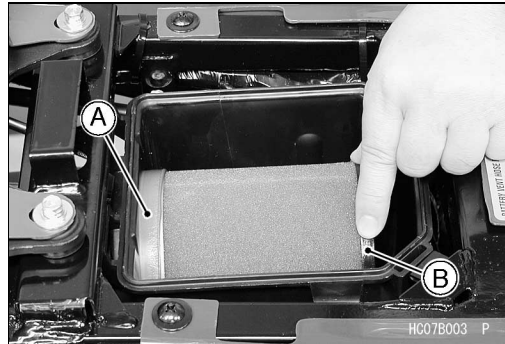

Air Cleaner Element Cleaning and Inspection

- Refer to Air Cleaner Element Cleaning and Inspection in Periodic Maintenance chapter.

Air Cleaner Draining

- Refer to Air Cleaner Draining in Periodic Maintenance chapter.

Air Cleaner Housing Removal

- Remove:
 - Seat (see Frame chapter)
 - Air Cleaner Element (see Air Cleaner Element Removal)
 - Housing Mounting Bolts [A]

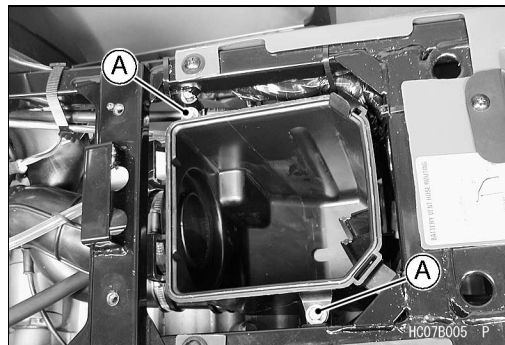

- Remove:
 - Snokel Duct [A]
 - Air Ducts [B]

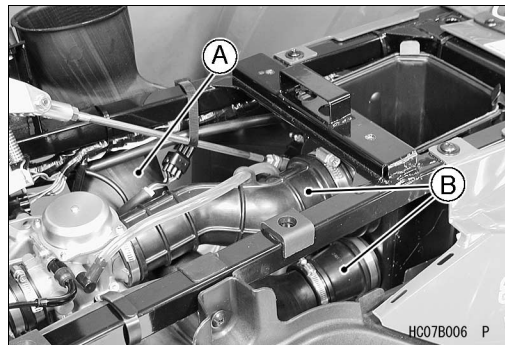

- Remove:
 - Breather Hose [A]

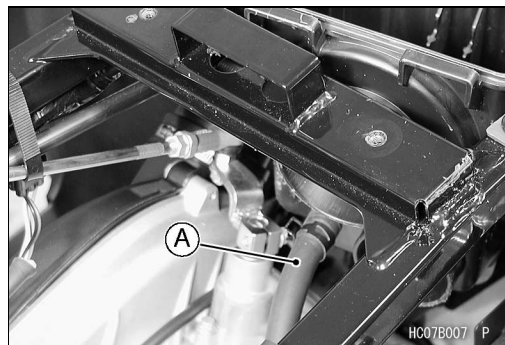

Air Cleaner

- Through the housing [A] under the bracket [B].

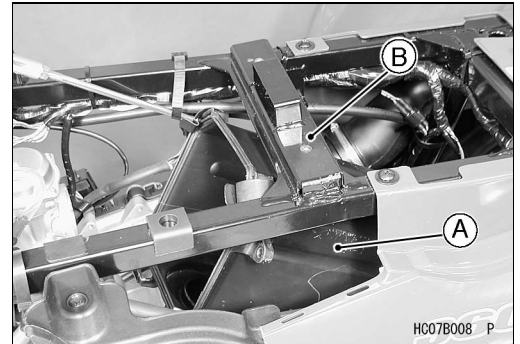

- Turn the housing counterclockwise at right angle [A] and take it as shown.

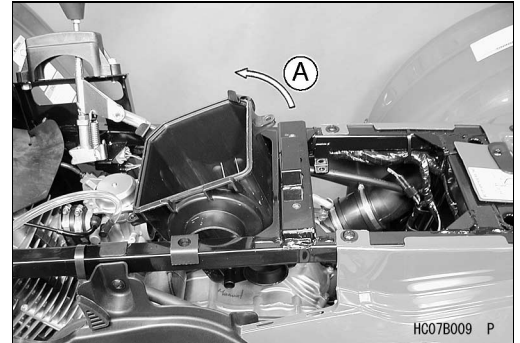

Air Cleaner Housing Installation

- Align [A] the notch in the duct with the ridge on the air cleaner housing.
- Tighten:

- Torque -**
- Air Cleaner Housing Mounting Bolts:** 6.9 N·m (0.7 kgf·m, 61 in·lb)
 - Air Cleaner Duct Rear Clamp Screw:** 4 N·m (0.41 kgf·m, 36 in·lb)
 - Air Cleaner Intake Duct Clamp Screws:** 1.4 N·m (0.14 kgf·m, 12 in·lb)

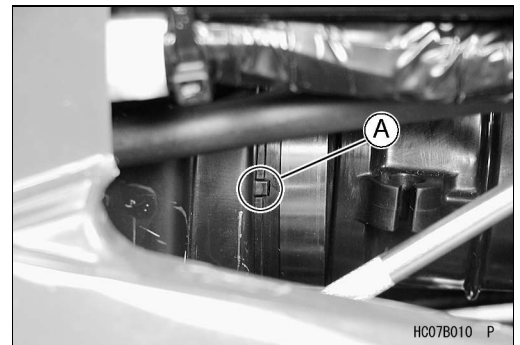

Snorkel Duct Removal

- Remove:
 - Seat (see Frame chapter)
 - Fuel Tank Cover (see Frame chapter)
 - Clamp [A]
 - Screws [B]
 - Snorkel Duct [C]

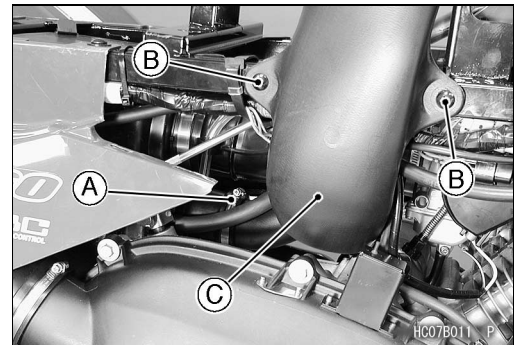

3-22 FUEL SYSTEM

Fuel Tank

Fuel Tank Removal

- Turn the fuel tap to the OFF position.
- Remove:
 - Screw [A]
 - Fuel Tap Knob [B]

⚠ WARNING

Gasoline is extremely flammable and can be explosive under certain conditions. Turn the ignition switch OFF. Do not smoke. Make sure the area is well ventilated and free from any source of flame or sparks; this includes any appliance with a pilot light.

- Remove:
 - Seat (see Frame chapter)
 - Fuel Tank Cover (see Frame chapter)
 - Exhaust Pipe Cover (see Frame chapter)
 - Fuel Hose [A]
 - Fuel Tank
- Remove the fuel tank and fuel tap from the vehicle, then be careful with the choke cable.

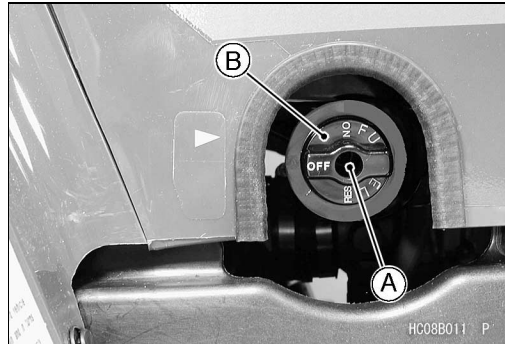

Fuel Tank Installation

⚠ WARNING

Gasoline is extremely flammable and can be explosive under certain conditions. Turn the ignition switch OFF. Do not smoke. Make sure the area is well ventilated and free from any source of flame or sparks; this includes any appliance with a pilot light.

- Check the rubber dampers [A].
- Check the grommets [B].
- ★ If the dampers are damaged or deteriorated, replace them.

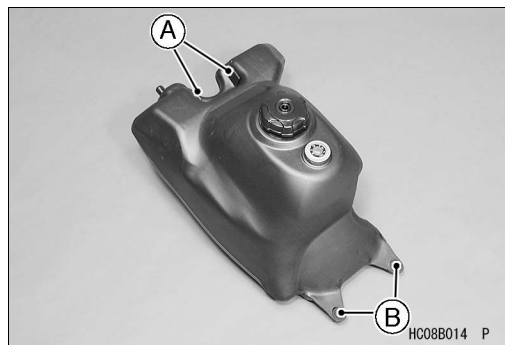
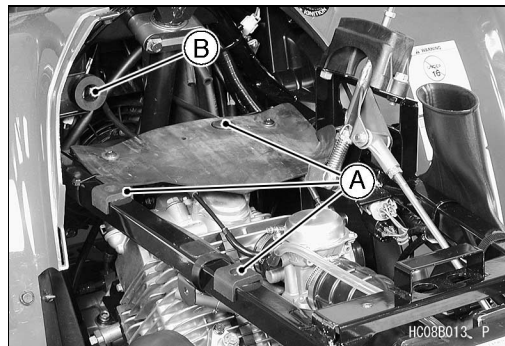

- Insert the projection [A] on the fuel tank into the damper grommet [B].
- When installing the fuel tank, be careful with the choke cable.
- Be sure the fuel hose is clamped to the fuel tap to prevent leakage.

⚠ WARNING

Fuel spilled from the fuel tap is hazardous.

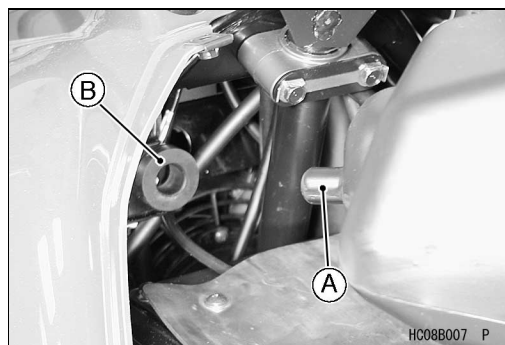

Fuel Tank

Fuel Tap Removal

- Remove the fuel tank and drain it (see Fuel Tank Removal).
- Remove:
 - Bolts [A]
 - Fuel Tap [B]

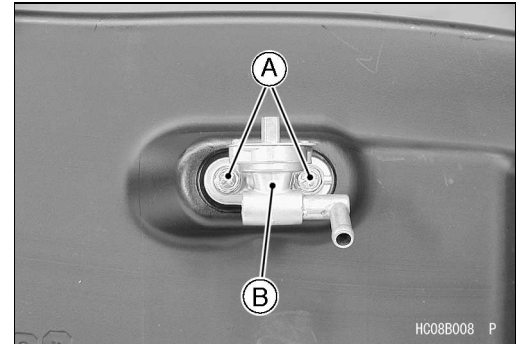

Fuel Tap Installation

- Be sure the O-rings [A] are in good condition to prevent leakage.

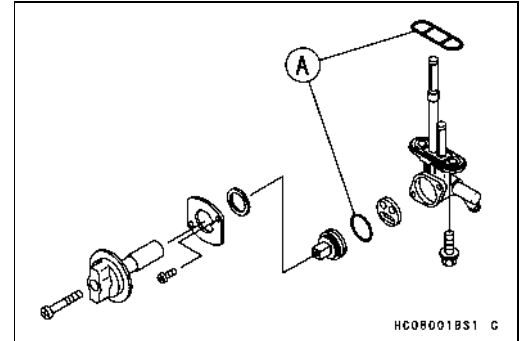

Fuel Tank and Fuel Tap Cleaning

- Remove the fuel tank and drain it (see Fuel Tank Removal).
- Pour some high-flash point solvent into the fuel tank and shake the tank to remove dirt and fuel deposits.

WARNING

Clean the tank in a well-ventilated area, and take care that there is no spark or flame anywhere near the working area; this includes any appliance with a pilot light. Because of the danger of highly flammable liquids, do not use gasoline or low-flash point solvents to clean the tank. A fire or explosion could result.

- Pour the solvent out the tank.
- Remove the fuel tap from the tank by taking out the bolts.
- Clean the fuel tap filter screens in a high-flash point solvent.
- Pour high-flash point solvent through the tap in both ON and RES positions.
- Dry the tank and tap with compressed air.
- Install the fuel tap in the tank (see Fuel Tap Installation).
- Install the fuel tank (see Fuel Tank Installation).

Fuel Tap Inspection

- Check the fuel tap filter screens [A] for any breaks or deterioration.
- ★ If the filter screens have any breaks or are deteriorated, it may allow dirt to reach the carburetor, causing poor running. Replace the fuel tap.

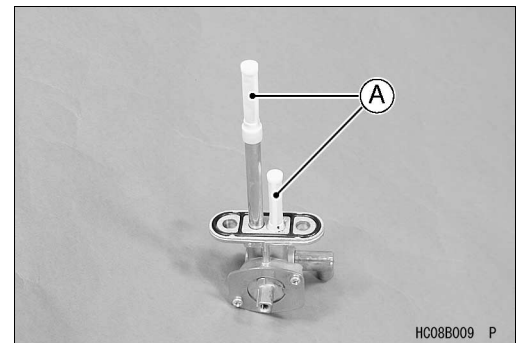

3-24 FUEL SYSTEM

Fuel Tank

- ★ If the fuel tap leaks, or allows fuel to flow when it is OFF, replace the damaged gasket [A] or O-rings [B].

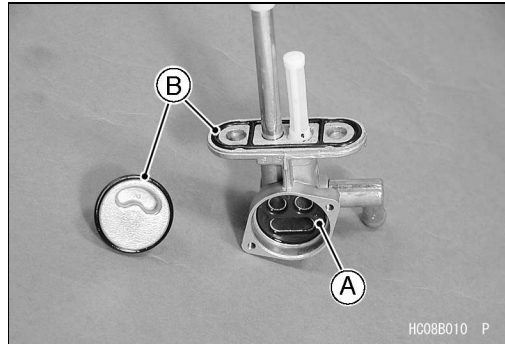

Fuel Level Gauge Removal

- Remove the fuel tank cap.

WARNING

Gasoline is extremely flammable and can be explosive under certain conditions. Turn the ignition switch OFF. Do not smoke. Make sure the area is well ventilated and free from any source of flame or sparks; this includes any appliance with a pilot light.

- Remove the fuel tank cover (see Fuel Tank Removal).
- Install the fuel tank cap immediately.
- Pry off the gauge cap [A] and discard the cap.
- Check the grooves [B] in the fuel tank boss. If the grooves are damaged by removing the cap or can not hold the cap nails, the fuel tank must be replaced.
- Pull out the fuel level gauge [C].

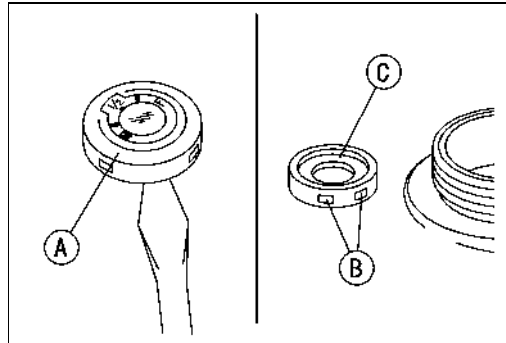

Fuel Level Gauge Installation

WARNING

Gasoline is extremely flammable and can be explosive under certain conditions. Turn the ignition switch OFF. Do not smoke. Make sure the area is well ventilated and free from any source of flame or sparks; this includes any appliance with a pilot light.

- Install the fuel level gauge so that the 1/2 scale [A] faces the front [B].
- Push the new gauge cap over the gauge so that the notch [C] aligns with the 1/2 scale.
- Check that the gauge cap nails fit securely in the grooves in the fuel tank boss.

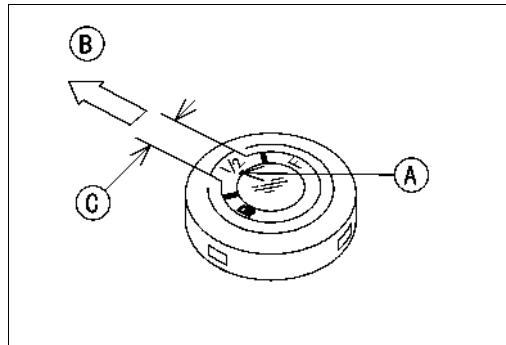

Fuel Level Gauge Check

- Remove the fuel level gauge from the fuel tank (see Fuel Level Gauge Removal).
- Check that the float [A] moves up and down [B] smoothly without binding. It should go down under its own weight.
- ★ If the float does not move smoothly or has visual damage, replace the gauge.

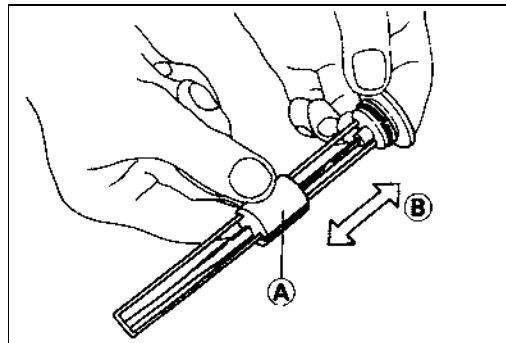

Engine Top End

Table of Contents

Exploded View.....	4-2	Cylinder Head Warp.....	4-20
Specifications.....	4-6	Valves, Guides, Seats, Springs, Oil Seals.....	4-21
Camshaft Chain Tensioner.....	4-8	Valve Clearance Inspection.....	4-21
Camshaft Chain Tensioner Removal.....	4-8	Valve Clearance Adjustment.....	4-21
Camshaft Chain Tensioner Installation.....	4-8	Valve Removal.....	4-21
Camshaft Sprocket.....	4-10	Valve Installation.....	4-22
Camshaft Sprocket Removal.....	4-10	Valve Visual Inspection.....	4-22
Camshaft Sprocket Installation.....	4-10	Valve Guide Removal.....	4-22
Rocker Arms and Shafts.....	4-12	Valve Guide Installation.....	4-22
Rocker Arm and Shaft Removal.....	4-12	Valve-to-Guide Clearance Measurement.....	4-23
Rocker Arm and Shaft Installation.....	4-12	Valve Seat Inspection.....	4-23
Rocker Arm and Shaft Inspection.....	4-13	Valve Seat Repair (Valve Lapping).....	4-24
Camshaft.....	4-14	Cylinder and Piston.....	4-28
Camshaft Removal.....	4-14	Cylinder Removal.....	4-28
Camshaft Installation.....	4-14	Cylinder Installation.....	4-28
Cam Wear Inspection.....	4-14	Cylinder Assembly.....	4-29
KACR Inspection.....	4-15	Piston Removal.....	4-29
Camshaft Chain and Guides.....	4-16	Piston Installation.....	4-30
Camshaft Chain Removal.....	4-16	Cylinder/Piston Wear.....	4-31
Camshaft Chain Installation.....	4-16	Piston/Cylinder Clearance.....	4-31
Camshaft Chain Guide Removal.....	4-16	Piston Ring and Ring Groove Wear.....	4-31
Camshaft Chain Guide Installation.....	4-16	Piston Ring Groove Width.....	4-32
Camshaft Chain Guide Wear.....	4-16	Piston Ring Thickness.....	4-32
Cylinder Head.....	4-17	Piston Ring End Gap Measurement.....	4-32
Cylinder Compression Measurement.....	4-17	Exhaust System.....	4-33
Cylinder Head Removal.....	4-17	Spark Arrester Cleaning.....	4-33
Cylinder Head Installation.....	4-18	Muffler Removal.....	4-33
Cylinder Head Assembly.....	4-19	Exhaust Pipe Removal.....	4-33
Cylinder Head Cleaning.....	4-19	Exhaust Pipe and Muffler Installation.....	4-33
		Exhaust System Inspection.....	4-33

4-2 ENGINE TOP END

Exploded View

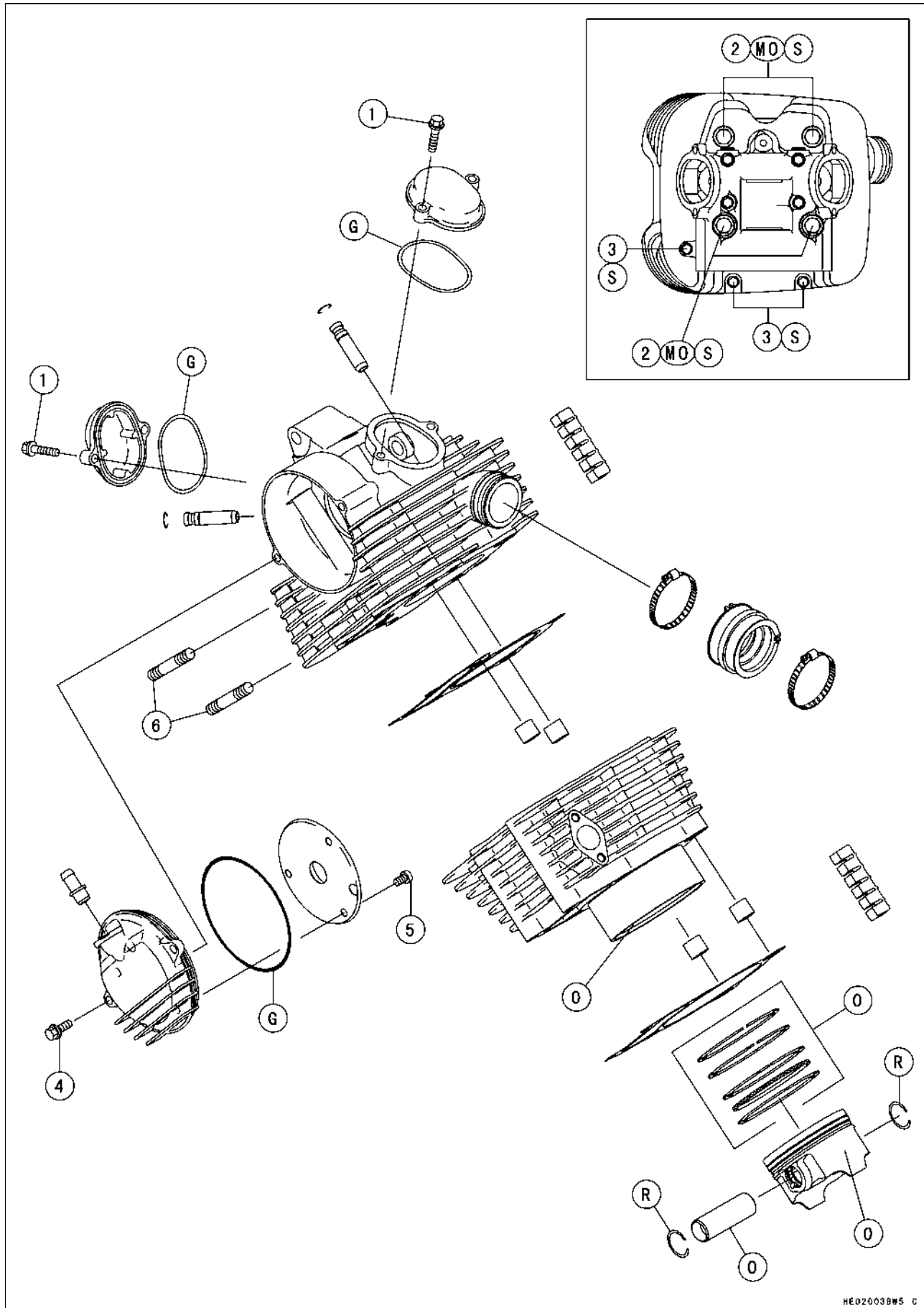

Exploded View

No.	Fastener	Torque			Remarks
		N·m	kgf·m	ft·lb	
1	Valve Adjusting Cap Bolts	8.8	0.9	78 in·lb	
2	Cylinder Head Bolts (M11), first torque	25	2.5	18	MO, S
2	Cylinder Head Bolts (M11), final torque	44	4.5	33	S
3	Cylinder Head Bolts (M6)	12	1.2	104 in·lb	S
4	Camshaft Cover Bolts	8.8	0.9	78 in·lb	
5	Engine Breather Plate Screws	4.4	0.45	39 in·lb	

6. Face the round end outward.

G: Apply grease for oil seal and O-ring.

MO: Apply molybdenum disulfide oil.

S: Follow the specific tightening sequence.

O: Apply engine oil.

R: Replacement Parts

4-4 ENGINE TOP END

Exploded View

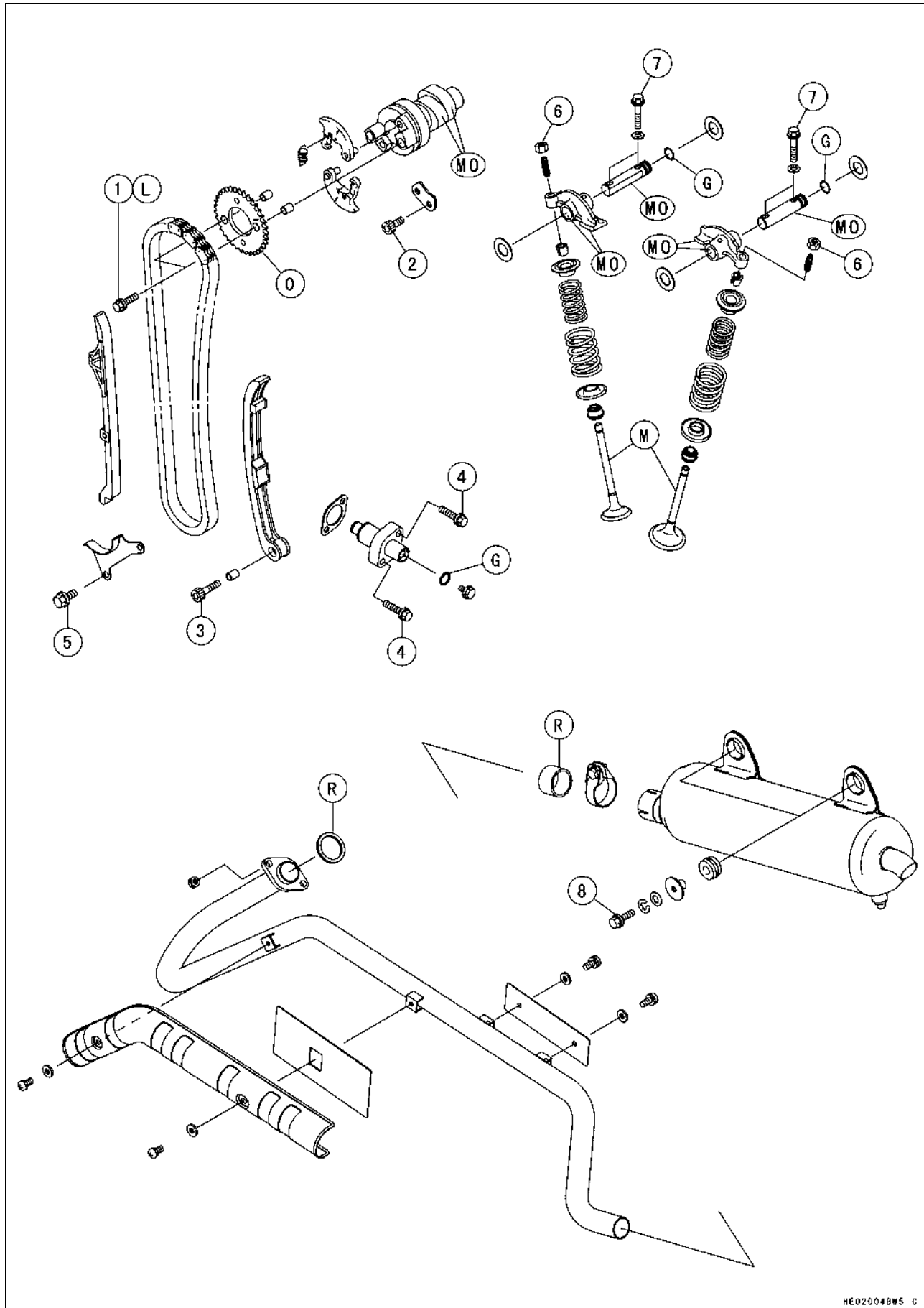

Exploded View

No.	Fastener	Torque			Remarks
		N·m	kgf·m	ft·lb	
1	Camshaft Sprocket Bolts	14	1.4	10	L
2	Bearing Retainer Bolts	12	1.2	104 in·lb	
3	Rear Camshaft Chain Guide Bolt	9.8	1.0	87 in·lb	
4	Camshaft Chain Tensioner Mounting Bolts	8.8	0.9	78 in·lb	
5	Camshaft Chain Guard Bolts	8.8	0.9	78 in·lb	
6	Valve Adjusting Screw Locknuts	12	1.2	104 in·lb	
7	Rocker Shaft Holder Bolts	8.8	0.9	78 in·lb	
8	Muffler Mounting Bolts	26	2.7	20	

G: Apply grease for oil seal and O-ring.

L: Apply a non-permanent locking agent.

MO: Apply molybdenum disulfide oil.

M: Apply molybdenum disulfide grease.

O: Apply engine oil.

R: Replacement Parts

4-6 ENGINE TOP END

Specifications

Item	Standard	Service Limit
Rocker Arms and Shafts		
Rocker arm inside diameter	13.000 ~ 13.018 mm (0.5118 ~ 0.5125 in.)	13.05 mm (0.514 in.)
Rocker shaft diameter	12.973 ~ 12.984 mm (0.5107 ~ 0.5112 in.)	12.95 mm (0.510 in.)
Camshaft:		
Cam height: Exhaust	40.693 ~ 41.801 mm (1.6021 ~ 1.6063 in.)	40.59 mm (1.598 in.)
Inlet	40.837 ~ 40.945 mm (1.6078 ~ 1.6120 in.)	40.74 mm (1.604 in.)
Cylinder Head:		
Cylinder compression: Electric starter @630 r/min (rpm)	(Usable Range) 810 ~ 1260 kPa (8.3 ~ 12.8 kgf/cm ² , 118 ~ 182 psi)	---
Cylinder head warp	---	0.05 mm (0.002 in.)
Valves:		
Valve clearance:		
Exhaust	0.15 ~ 0.20 mm (0.0059 ~ 0.0079 in.)	---
Inlet	0.08 ~ 0.13 mm (0.0032 ~ 0.0051 in.)	---
Valve/valve guide clearance (wobble method):		
Exhaust	0.07 ~ 0.14 mm (0.0028 ~ 0.0055 in.)	0.30 mm (0.0118 in.)
Inlet	0.05 ~ 0.13 mm (0.0020 ~ 0.0051 in.)	0.30 mm (0.0118 in.)
Valve seating surface width:		
Exhaust	0.5 ~ 1.0 mm (0.02 ~ 0.04 in.)	---
Inlet	0.5 ~ 1.0 mm (0.02 ~ 0.04 in.)	---
Valve seating surface outside diameter:		
Exhaust	34.9 ~ 35.1 mm (1.374 ~ 1.382 in.)	---
Inlet	39.9 ~ 40.1 mm (1.571 ~ 1.579 in.)	---
Valve seat cutting angle	45°, 32°, 50°	---
Valve head thickness:		
Exhaust	1.0 mm (0.04 in.)	0.5 mm (0.020 in.)
Inlet	1.0 mm (0.04 in.)	0.7 mm (0.028 in.)
Valve stem bend	under 0.01 mm (0.0004 in.) TIR	0.05 mm (0.002 in.) TIR
Valve stem diameter:		
Exhaust	6.955 ~ 6.970 mm (0.2738 ~ 0.2744 in.)	6.94 mm (0.2732 in.)
Inlet	6.965 ~ 6.980 mm (0.2742 ~ 0.2748 in.)	6.95 mm (0.2736 in.)
Valve guide inside diameter:		
Exhaust	7.000 ~ 7.015 mm (0.2756 ~ 0.2762 in.)	7.08 mm (0.279 in.)
Inlet	7.000 ~ 7.015 mm (0.2756 ~ 0.2762 in.)	7.08 mm (0.279 in.)
Valve spring free length:		
Inner	39.05 mm (1.537 in.)	36.7 mm (1.445 in.)
Outer	42.47 mm (1.672 in.)	40.0 mm (1.575 in.)
Cylinder, Piston:		
Cylinder inside diameter	80.000 ~ 80.012 mm (3.1496 ~ 3.1501 in.)	80.10 mm (3.154 in.)
Piston diameter	79.952 ~ 79.967 mm (3.1477 ~ 3.1483 in.)	79.80 mm (3.142 in.)
Piston/cylinder clearance	0.033 ~ 0.060 mm (0.0013 ~ 0.0024 in.)	---
Piston ring/groove clearance:		
Top	0.04 ~ 0.08 mm (0.0016 ~ 0.0032 in.)	0.18 mm (0.0071 in.)
Second	0.03 ~ 0.07 mm (0.0012 ~ 0.0028 in.)	0.17 mm (0.0067 in.)
Piston ring thickness:		
Top	0.97 ~ 0.99 mm (0.0382 ~ 0.0390 in.)	0.90 mm (0.035 in.)
Second	0.97 ~ 0.99 mm (0.0382 ~ 0.0390 in.)	0.90 mm (0.035 in.)
Piston ring groove width:		
Top	1.03 ~ 1.05 mm (0.0405 ~ 0.0413 in.)	1.13 mm (0.0445 in.)
Second	1.02 ~ 1.04 mm (0.0402 ~ 0.0409 in.)	1.12 mm (0.0441 in.)
Piston ring end gap:		
Top	0.20 ~ 0.30 mm (0.0079 ~ 0.0118 in.)	0.6 mm (0.0236 in.)
Second	0.30 ~ 0.45 mm (0.0118 ~ 0.0177 in.)	0.8 mm (0.0315 in.)
Oil	0.20 ~ 0.70 mm (0.0079 ~ 0.0276 in.)	1.0 mm (0.0394 in.)

Specifications

Special Tools - Valve Guide Reamer, $\phi 7$: 57001-162
Valve Guide Arbor, $\phi 7$: 57001-163
Compression Gauge: 57001-221
Valve Spring Compressor Assembly: 57001-241
Valve Spring Compressor Adapter, $\phi 28.2$: 57001-243
Piston Pin Puller Assembly: 57001-910
Compression Gauge Adapter, M12 x 1.25: 57001-1018
Valve Seat Cutter, $45^\circ - \phi 41.5$: 57001-1117
Valve Seat Cutter, $32^\circ - \phi 38.5$: 57001-1122
Valve Seat Cutter Holder, $\phi 7$: 57001-1126
Valve Seat Cutter Holder Bar: 57001-1128
Piston Pin Puller Adapter: 57001-1211
Filler Cap Driver: 57001-1454
Valve Seat Cutter, $32^\circ - \phi 44$: 57001-1515
Valve Seat Cutter, $50^\circ - \phi 44$: 57001-1516

4-8 ENGINE TOP END

Camshaft Chain Tensioner

Camshaft Chain Tensioner Removal

CAUTION

This is a non-return type camshaft chain tensioner. The push rod does not return to its original position once it moves out to take up camshaft chain slack. Observe all the rules listed below:

When removing the tensioner, do not take out the mounting bolts only halfway. Retightening the mounting bolts from this position could damage the tensioner and the camshaft chain. Once the bolts are loosened, the tensioner must be removed and reset as described in "Camshaft Chain Tensioner Installation."

Do not turn over the crankshaft while the tensioner is removed. This could upset the camshaft chain timing, and damage the valves.

- Remove:
 - Fuel Tank Cover (see Frame chapter)
 - Exhaust Pipe Cover (see Frame chapter)
- Loosen the cap bolt [A].
- Remove the mounting bolts [B] and take off the camshaft chain tensioner.

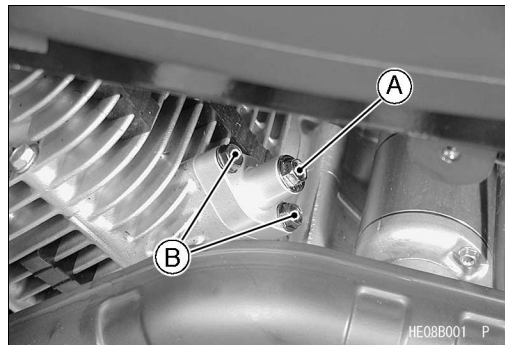

Camshaft Chain Tensioner Installation

- Remove the cap bolt and O-ring.
- While compressing [A] the push rod [B], turn it clockwise [C] with a suitable screwdriver [D] until the rod stops.
- While holding the rod in position with a holder plate, install the tensioner on the cylinder block.

CAUTION

Do not turn the rod counterclockwise at installation. This could detach the rod and the tensioner cannot be reinstalled.

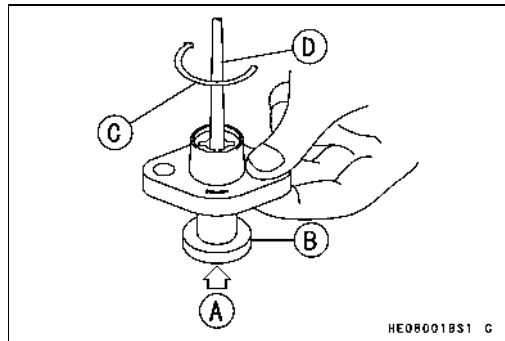

NOTE

- To make the procedure easy, use a holder plate [A] to keep the rod from pushing out. A replacement chain tensioner (spare parts) has a holder plate.
- The holder plate can be made of 0.8 mm (0.03 in.) thick aluminum plate as shown.
 - [B] 8.5 mm (0.33 in.)
 - [C] 3.5 mm (0.14 in.)
 - [D] 5 mm (0.20 in.)
 - [E] 12 mm (0.47 in.)

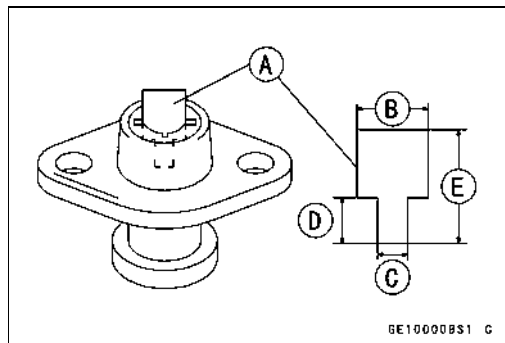

Camshaft Chain Tensioner

- Install a new gasket.
- Install the tensioner body with the arrow [A] on it pointing downwards.
- Tighten the mounting bolts [B].

Torque - Camshaft Chain Tensioner Mounting Bolts: 8.8 N·m (0.9 kgf·m, 78 in·lb)

- Remove the holder plate [C].
- Apply grease to the O-ring, and install it on the tensioner body.
- Tighten the cap bolt.
- Turn the crankshaft 2 turns counterclockwise to allow the tensioner to expand and recheck the camshaft chain timing.

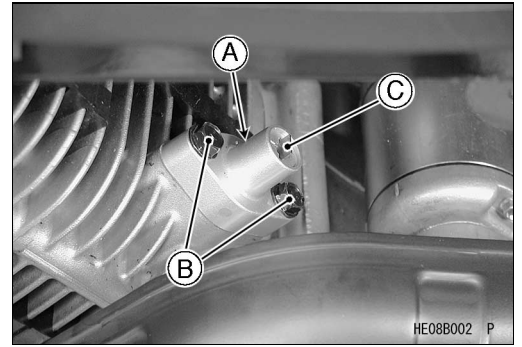

4-10 ENGINE TOP END

Camshaft Sprocket

Camshaft Sprocket Removal

- Remove:
 - Fuel Tank Cover (see Frame chapter)
 - Exhaust Pipe Cover (see Frame chapter)
 - Left Front Inner Cover (see Frame chapter)
 - Recoil Starter (see Recoil Starter chapter)
 - Bolts [A] and Camshaft Cover [B]
- Turn the crankshaft counterclockwise with a wrench on the alternator rotor bolt until the mark [A] on the camshaft sprocket aligns with the pointer [B] on the cylinder head.
- Be sure to position the crankshaft at TDC of the end of the compression stroke.
- Remove the camshaft chain tensioner (see Camshaft Chain Tensioner Removal).
- Remove the camshaft sprocket bolts [C].
- Hold the crankshaft from turning with a wrench on the alternator rotor bolt.
- Remove the camshaft sprocket [D].

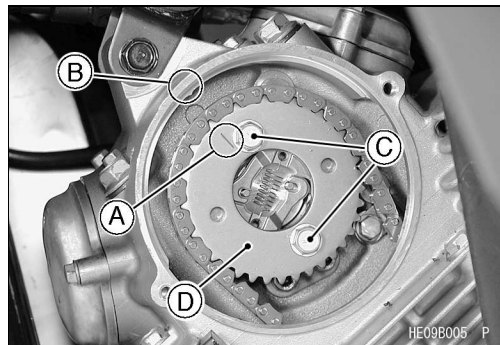
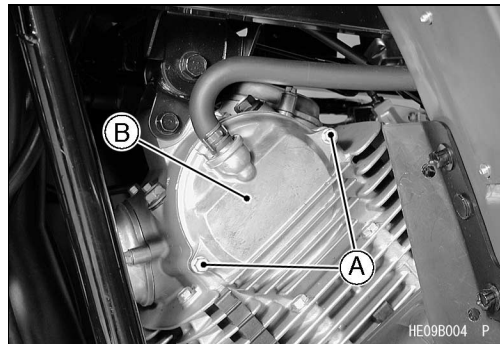

Camshaft Sprocket Installation

- Remove:
 - Timing Inspection Plug [A]
- **Special Tool - Driver - Filler Cap [B]: 57001-1454**
- Check that the "T" mark [A] on the alternator rotor aligns with the slot [B] in the alternator cover.
- Be sure to position the crankshaft at TDC of the end of the compression stroke.
- ★ If the "T" mark is not aligned, hold the camshaft chain taut and turn the crankshaft with a wrench on the alternator rotor bolt.
- Confirm the notching line [A] of the weight holder [B] aligns with the pointer [C] on the cylinder head.

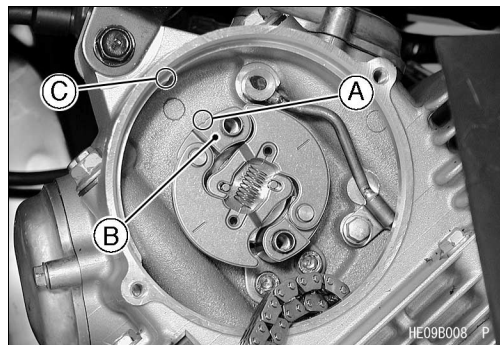
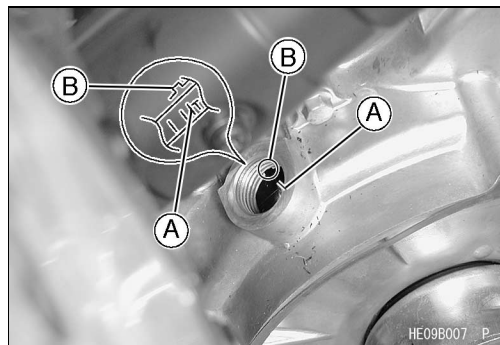
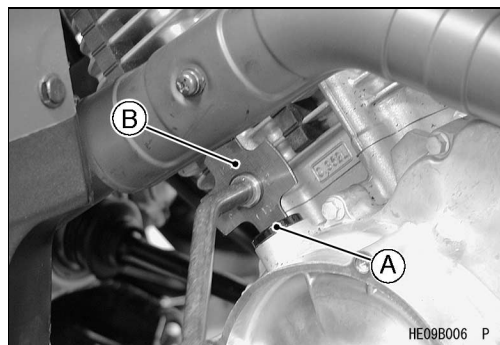

Camshaft Sprocket

- Fit the camshaft sprocket under the chain, and install the sprocket on the weights so that the mark [A] aligns with the pointer [B].
- Apply a non-permanent locking agent to the camshaft sprocket bolts and tighten them, while holding the crankshaft from turning with a wrench on the alternator rotor bolt.

Torque - Camshaft Sprocket Bolts: 14 N·m (1.4 kgf·m, 10 ft·lb)

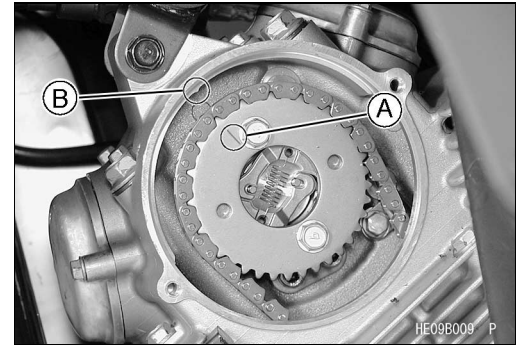

- Install the camshaft chain tensioner (see Camshaft Chain Tensioner Installation).
- Before going any further, check the cam timing.
- Turn the crankshaft counterclockwise with a wrench on the alternator rotor bolt, until the mark on the sprocket realigns with the pointer on the head.

CAUTION

If any resistance is felt when turning the crankshaft, stop immediately, or you may bend the valves.

- The "T" mark on the alternator rotor should align with the slot.
- ★ If the camshaft timing is not correct, remove the sprocket from the camshaft, and install it again as detailed above.
- Apply grease to the O-ring [A], and push the cover into place.
- Tighten:

Torque - Camshaft Cover Bolts: 8.8 N·m (0.9 kgf·m, 78 in·lb)
- Install the timing inspection plug.
- Special Tool - Driver - Filler Cap: 57001-1454**

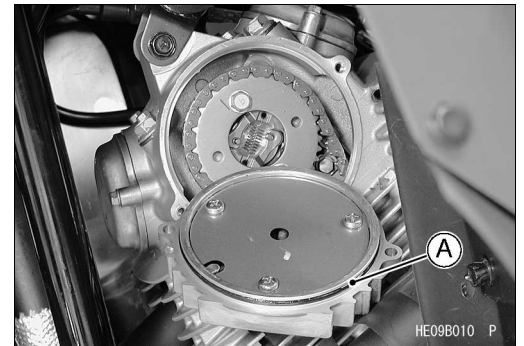

4-12 ENGINE TOP END

Rocker Arms and Shafts

Rocker Arm and Shaft Removal

- Remove:
 - Recoil Starter (see Recoil Starter chapter)
- Position the crankshaft at TDC of the end of the compression stroke (see Camshaft Sprocket Installation).

Rear Side:

- Remove:
 - Fuel Tank (see Fuel System chapter)
 - Rubber Cover
 - Valve Adjusting Cap Bolts [A]
 - Valve Adjusting Cap [B]
 - Rocker Shaft Holder Bolts [C]
 - Rocker Shaft [D]
 - Washers
- Push the rocker arm [A] in the rocker case, and turn it in place.

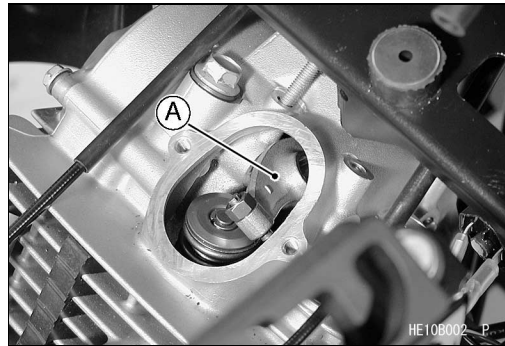
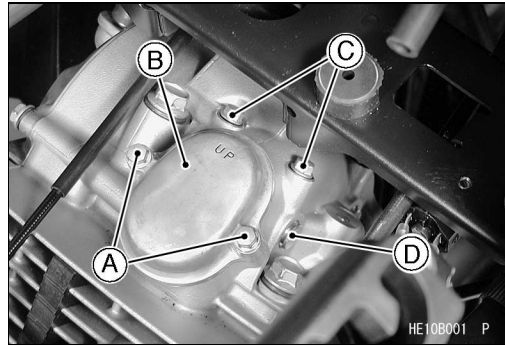

- Remove the rocker arm [A].

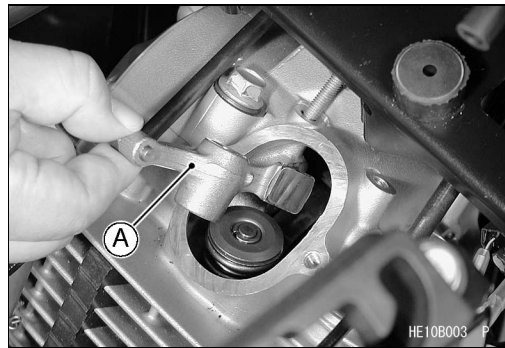

Front Side:

- Remove:
 - Right Front Inner Cover (see Frame chapter)
 - Converter Air Intake Duct
 - Cylinder Head Bolt [A]
 - Valve Adjusting Cap [B]
 - Rocker Shaft Holder Bolts [C]
 - Rocker Shaft [D]
 - Washers
- Remove the rocker arm in the same manner as above.

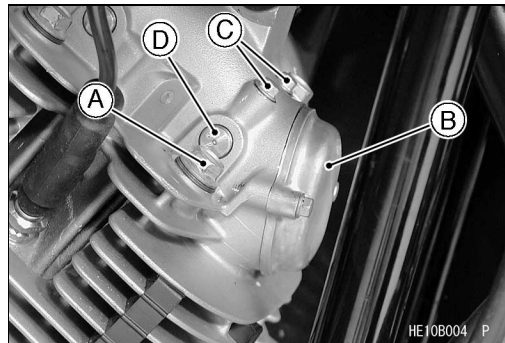

Rocker Arm and Shaft Installation

- Apply molybdenum disulfide oil to the rocker shaft [A].
- Install:
 - Rocker Arm [B]
 - Washers [C]
 - Rocker Shaft

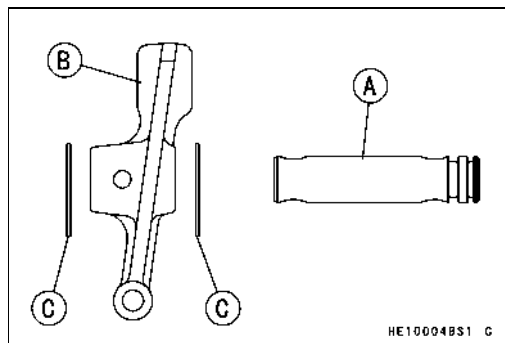

Rocker Arms and Shafts

- Install the rocker shafts [A] so that the punch marks [B] facing to the camshaft.
- Tighten:

Torque - Rocker Shaft Holder Bolts: 8.8 N·m (0.9 kgf·m, 78 in·lb)

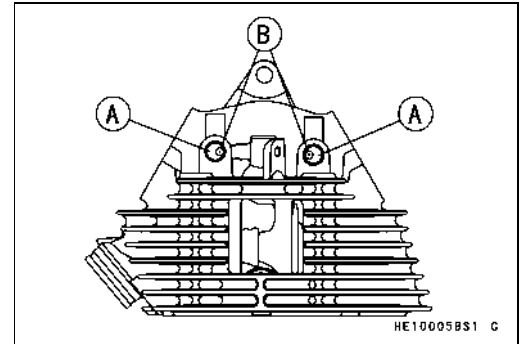

Rocker Arm and Shaft Inspection

- Inspect the area [A] on the rocker arm where the cam rubs.
- ★ If the rocker arm is scored, discolored or otherwise damaged, replace it. Also inspect the camshaft lobes.
- Inspect the end of the valve clearance adjusting screw [B] where it contacts the valve stem.
- ★ If the end of the adjusting screw is mushroomed or damaged in any way, or if the screw will not turn smoothly, replace it. Also inspect the end of the valve stem.
- Measure the inside diameter [C] of the rocker arm with a dial bore gauge.
- ★ If the rocker arm inside diameter is larger than the service limit, replace it. Also check the rocker shaft diameter [D].

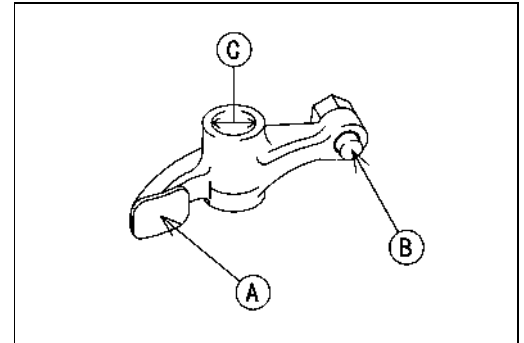

Rocker Arm Inside Diameter

Standard: 13.000 ~ 13.018 mm (0.5118 ~ 0.5125 in.)

Service Limit: 13.05 mm (0.514 in.)

- Measure the diameter of the rocker shaft where the rocker arm pivots on it with a micrometer.
- ★ If the rocker shaft diameter is smaller than the service limit, replace it.

Rocker Shaft Diameter

Standard: 12.973 ~ 12.984 mm (0.5107 ~ 0.5112 in.)

Service Limit: 12.95 mm (0.510 in.)

4-14 ENGINE TOP END

Camshaft

Camshaft Removal

- Remove:
 - Camshaft Sprocket (see Camshaft Sprocket Removal)
 - Weights [A]
- Loosen the cylinder head bolts [B].

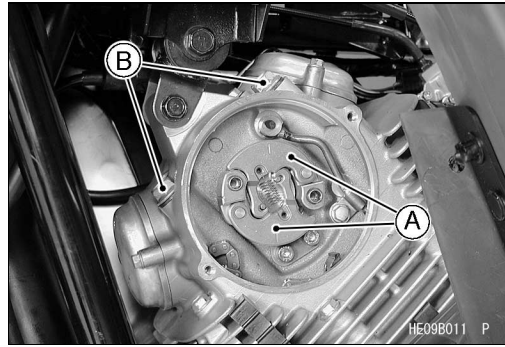

- Remove:
 - Bolts [A] and Bearing Retainer [B]
- Pull the camshaft [C] straight out of the head.
- Screw the camshaft sprocket bolt in to the end of the camshaft and pull it with the camshaft.

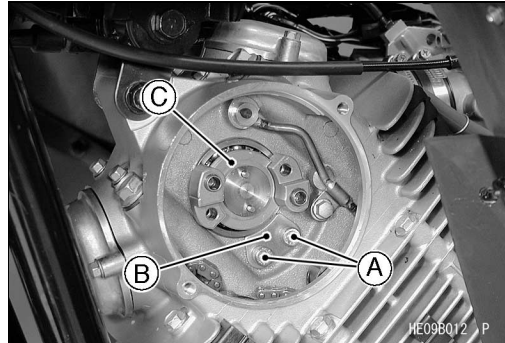

Camshaft Installation

- Blow the oil passage with compressed air.
- Apply molybdenum disulfide oil to the cam lobes [A].
- Carefully push the camshaft into the cylinder head with the cam lobes "down".
- Install:
 - Bearing Retainer
- Tighten:
 - Torque - Bearing Retainer Bolts: 12 N·m (1.2 kgf·m, 104 ft·lb)

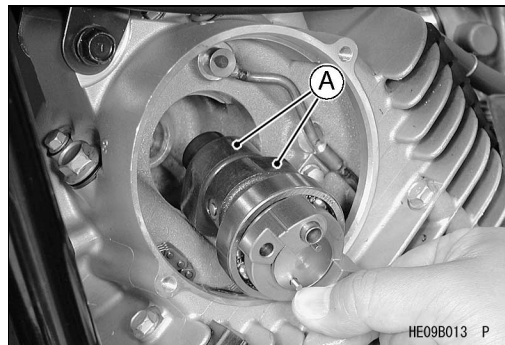

- Align the notching line [A] of the weight holder [B] with the pointer [C] on the cylinder head.
- Tighten the loosened cylinder head bolts (see Cylinder Head Installation).

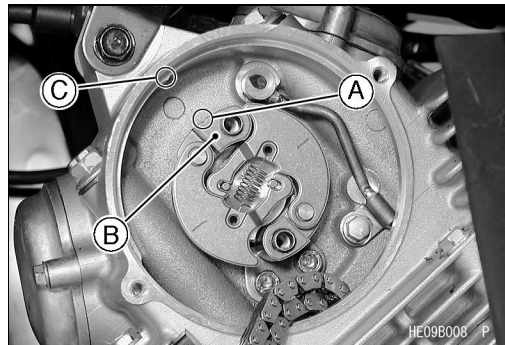

Cam Wear Inspection

- Measure the height of each cam lobe with a micrometer.
- ★ If the cam height is less than the service limit for either lobe, replace the camshaft.

Cam Height

	Standard	Service Limit
Exhaust	40.693 ~ 41.801 mm (1.6021 ~ 1.6063 in.)	40.59 mm (1.598 in.)
Inlet	40.837 ~ 40.945 mm (1.6078 ~ 1.6120 in.)	40.74 mm (1.604 in.)

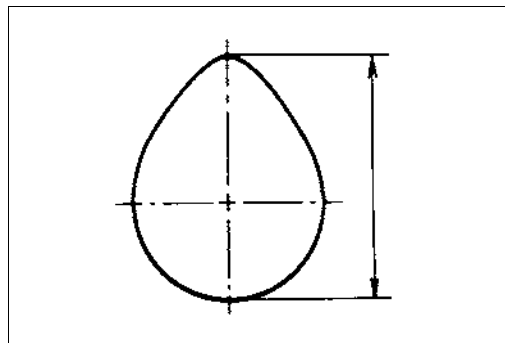

Camshaft

Camshaft Bearing Inspection

- Check the ball bearing which is press-fitted on the camshaft.
- Since the ball bearing is made to extremely close tolerances, the wear must be judged by feel rather than measurement. Clean the bearing in a high-flash point solvent, dry it (do not spin the bearing while it is dry), and oil it with engine oil.
- Spin the bearing by hand to check its condition.
- ★ If the bearing is noisy, does not spin smoothly, or has any rough stops, replace it.

KACR Inspection

The Kawasaki Automatic Compression Release (KACR) momentarily opens the exhaust valves on the compression stroke at very low speeds. This allows some of the compression pressure to escape, making it easy to turn over the engine during starting.

Due to the simplicity of the mechanism, no periodic maintenance is needed. There are only two symptoms of problems with the KACR mechanism [A]: compression is not released during starting, and compression is released during running.

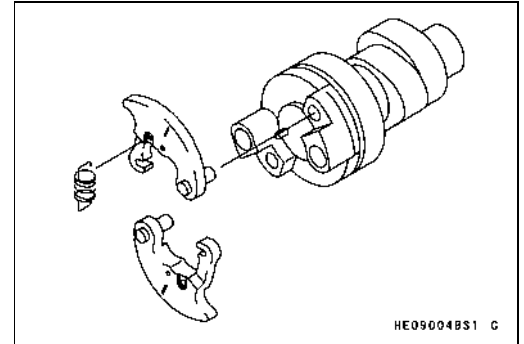

(1) If compression is not released during starting, the weights are not returning to their rest position.

- Remove the camshaft (see Camshaft Removal).
- Remove the KACR unit.
- Visually inspect the spring.
- ★ If damaged, deformed, or missing, replace the spring.
- Remove the spring and move the weights back and forth.
- ★ If the weights do not move smoothly, replace the KACR unit. Also inspect the exhaust rocker arm for any damage, and replace the rocker arm if necessary.

[A] Rest Position (compression is released)

[B] Weights

[C] Spring

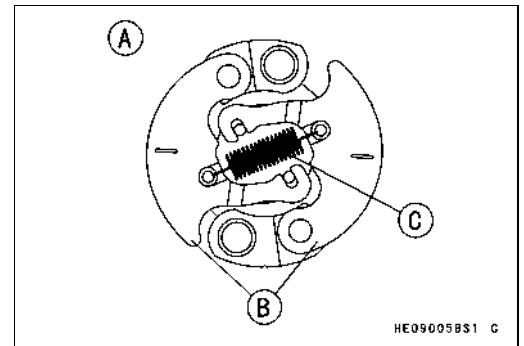

(2) If compression is released while the engine is running, the weights are not swinging out.

- Remove the spring and move the weights back and forth.
- ★ If the weights do not move easily from the retracted position, replace the KACR unit. Also inspect the exhaust rocker arm for any damage, and replace the rocker arm if necessary.

[A] Running Position (compression is not released)

[B] Weights

[C] Spring

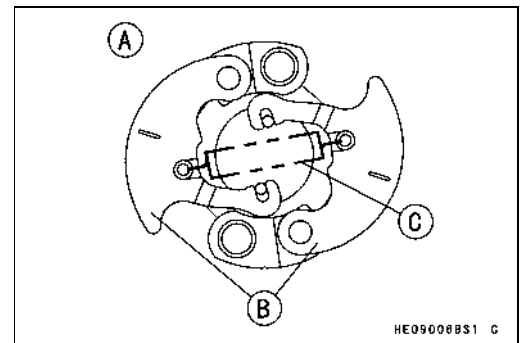

4-16 ENGINE TOP END

Camshaft Chain and Guides

Camshaft Chain Removal

- Remove:
 - Camshaft Sprocket (see Camshaft Sprocket Removal)
 - Starter Clutch Gear (see Alternator Rotor Removal section in Electrical System chapter)
 - Bolts [A] and Camshaft Chain Guard [B]
 - Camshaft Chain [C]

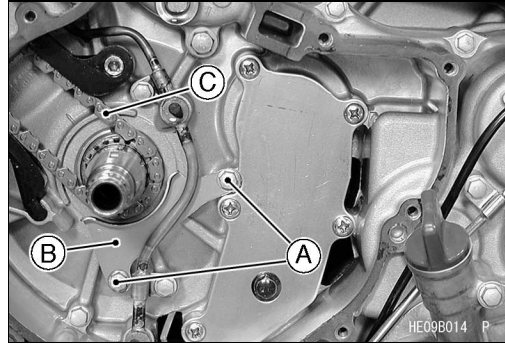

Camshaft Chain Installation

CAUTION

Always pull the camshaft chain taut while turning the crankshaft when the camshaft chain is loose. This avoids kinking the chain on the lower (crankshaft) sprocket. A kinked chain could damage both the chain and the sprocket.

- Tighten:
 - Torque - Camshaft Chain Guard Bolts: 8.8 N·m (0.9 kgf·m, 78 in·lb)

Camshaft Chain Guide Removal

- Remove:
 - Cylinder Head (see Cylinder Head Removal)
 - Starter Clutch Gear (see Alternator Rotor Removal section in Electrical System chapter)
 - Front Camshaft Chain Guide [A]
 - Bolt [B] and Rear Camshaft Chain Guide [C]

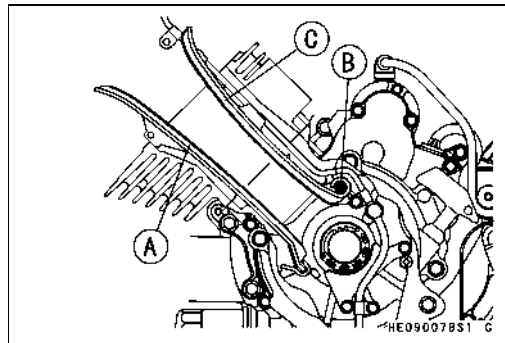

Camshaft Chain Guide Installation

- Slip the front camshaft chain guide [A] into the position [B].
- Install:
 - Rear Camshaft Chain Guide [C]
 - Collar [D]
- Tighten:
 - Torque - Rear Camshaft Chain Guide Bolt [E]: 9.8 N·m (1.0 kgf·m, 87 in·lb)

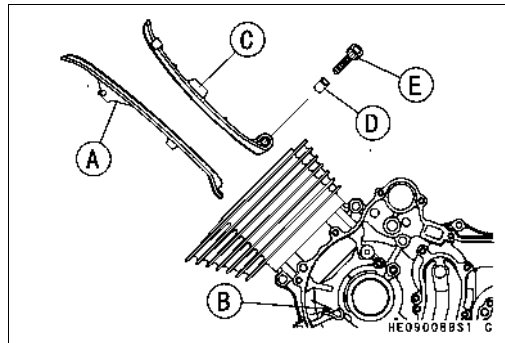

Camshaft Chain Guide Wear

- Visually inspect the rubber on the guides.
- ★ If the rubber is damaged, cut, or is missing pieces, replace the guide.

Cylinder Head

Cylinder Compression Measurement

NOTE

- Use the battery which is fully charged.
- Warm up the engine thoroughly, and stop the engine.
- Remove the spark plug (see Electrical System chapter).
- Attach the compression gauge [A] and adapter [B] firmly into the spark plug hole.

Special Tools - Compression Gauge: 57001-221

Compression Gauge Adapter, M12 × 1.25: 57001-1018

- Hold the throttle wide open and crank the engine with the electric starter or the recoil starter several times.
- When the gauge stops rising, stop cranking and read the gauge.

Cylinder Compression (Usable Range)

**Electric Starter: 810 ~ 1260 kPa (8.3 ~ 12.8 kgf/cm²,
118 ~ 182 psi) @630 r/min (rpm)**

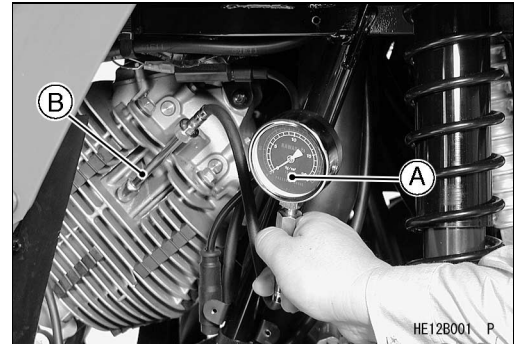

The following table should be consulted if the obtainable compression reading is not within the usable range.

Problem	Diagnosis	Remedy (Action)
Cylinder compression is higher than usable range	Carbon accumulation on piston, cylinder head, and in combustion chamber possibly due to damaged valve stem oil seal and/or damaged piston oil rings (This may be indicated by white exhaust smoke).	Remove the carbon deposits and replace damaged parts if necessary.
	Incorrect cylinder head gasket thickness.	Replace the gasket with a standard part.
	Damaged or missing compression release cam spring	Replace the spring.
	Compression release weights do not move smoothly.	Replace the compression release unit.
Cylinder compression is lower than usable range	Gas leakage around cylinder head	Replace damaged gasket and check cylinder head warp.
	Bad condition of valve seating	Repair if necessary.
	Incorrect valve clearance.	Adjust the valve clearance.
	Incorrect piston/cylinder clearance	Replace the piston and/or cylinder
	Piston seizure.	Inspect the cylinder and liner and replace/repair the cylinder and/or piston as necessary.
	Bad condition of piston ring and/or piston ring grooves	Replace the piston and/or the piston rings.
Compression release weights do not move smoothly	Replace the compression release unit	

Cylinder Head Removal

- Remove:
 - Fuel Tank, Carburetor (see Fuel System chapter)
 - Exhaust Pipe and Muffler (see Exhaust Pipe and Muffler Removal)
 - Camshaft Sprocket (see Camshaft Sprocket Removal)
 - Converter Air Intake Duct
 - Weights [A]
 - Oil Pipe Bolt [B]
 - Oil Pipe End [C]
 - Engine Mounting Bolt [D]
 - Spark Plug Cap

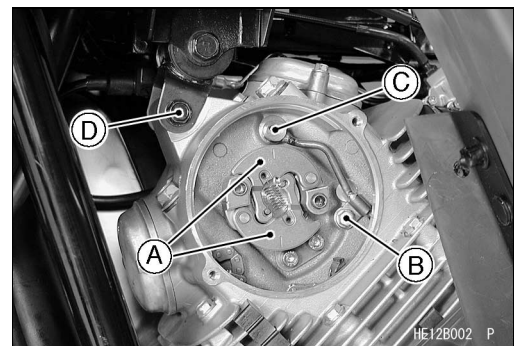

4-18 ENGINE TOP END

Cylinder Head

- Remove:
 - Rubber Cover
 - Bolts [A] and Cylinder Head Bracket [B]

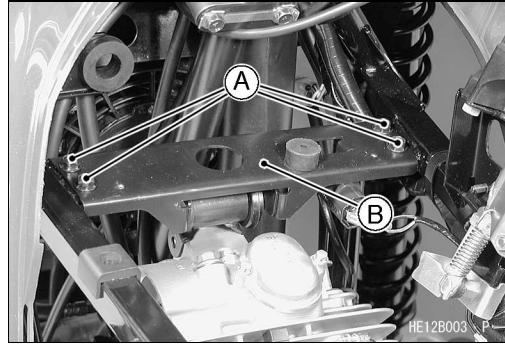

- Remove:
 - Cylinder Head Bolts (M6) [A]
 - Cylinder Head Bolts (M11) [B]
 - Cylinder Head

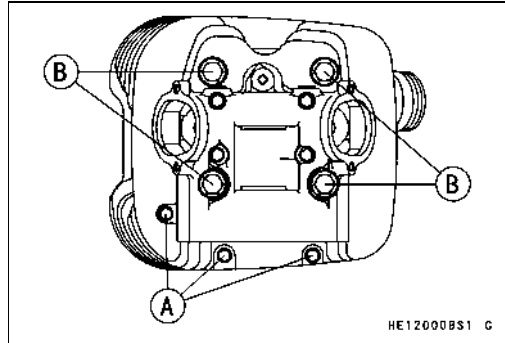

Cylinder Head Installation

- Install:
 - Dowel Pins [A]
 - New Cylinder Head Gasket [B]
- Be sure the camshaft chain guides are in place (see Camshaft Chain Guide Installation).

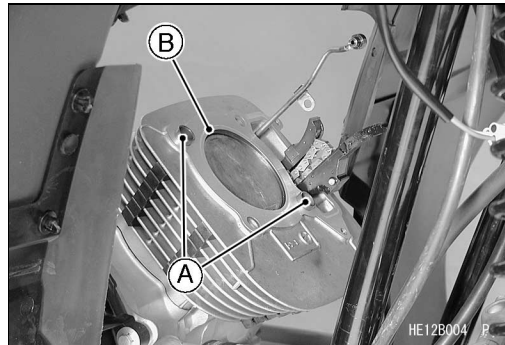

- Apply molybdenum disulfide oil to the M11 bolt threads and both sides of the washers.
- Tighten the cylinder head bolts [1~7] following the tightening sequence as shown.

[1, 4] L = 220 mm (8.7 in.)

[2, 3] L = 245 mm (9.6 in.)

Torque - (First) Cylinder Head Bolts (M11) [1~4]: 25 N·m (2.5 kgf·m, 18 ft·lb)

Torque - (Final) Cylinder Head Bolts (M11) [1~4]: 44 N·m (4.5 kgf·m, 33 ft·lb)

Torque - Cylinder Head Bolts (M6) [5~7]: 12 N·m (1.2 kgf·m, 104 ft·lb)

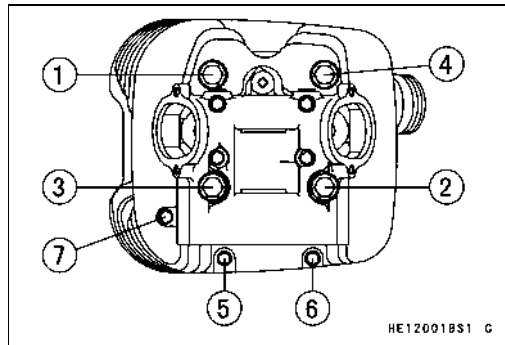

Cylinder Head

Cylinder Head Assembly

- Insert the rubber dampers [A] in the fin grooves.
 - [B] Left Side
 - [C] Right Side
 - [D] Rear Side
 - [E] 73 mm (2.87 in.)
 - [F] 57 mm (2.24 in.)
 - [G] 15 mm (0.59 in.)

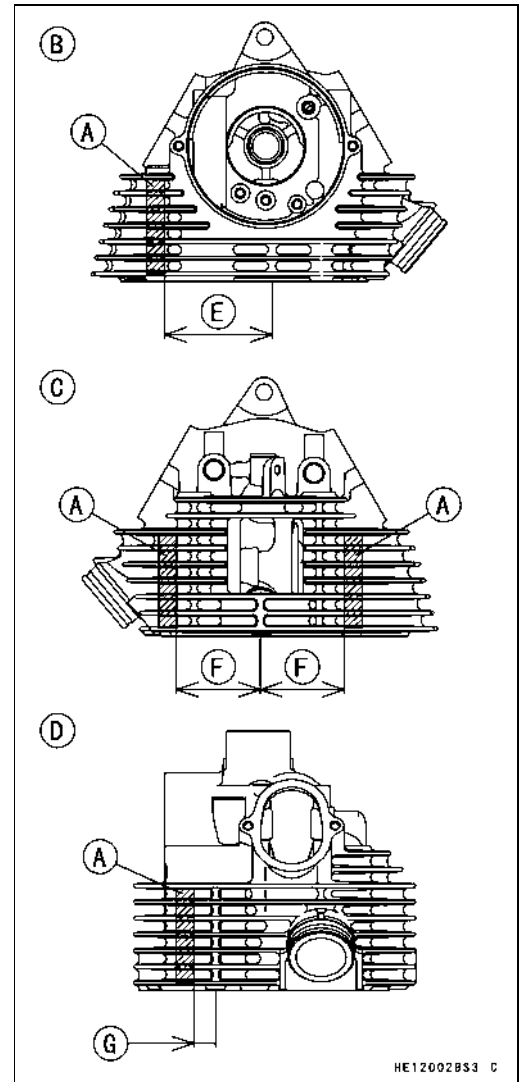

- Fit the groove [A] in the carburetor holder [B] on the projection [C] of the cylinder head.

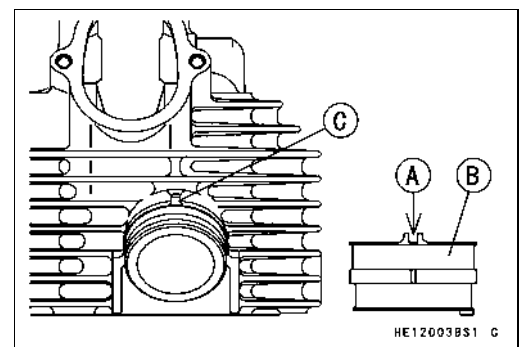

Cylinder Head Cleaning

- Remove the cylinder head (see Cylinder Head Removal).
- Scrape the carbon out of the combustion chamber and exhaust port with a suitable tool.
- Wash the head with a high-flash point solvent.

4-20 ENGINE TOP END

Cylinder Head

Cylinder Head Warp

- Clean the cylinder head (see Cylinder Head Cleaning).
- Lay a straightedge across the lower surface of the cylinder head.
- Use a thickness gauge [A] to measure the space between the straightedge [B] and the head at several locations.

Cylinder Head Warp

Service Limit: 0.05 mm (0.002 in.)

- ★ If the cylinder head is warped more than the service limit, replace it.
- ★ If the cylinder head is warped less than the service limit, repair the head by rubbing the lower surface on emery paper secured to a surface plate (first No. 200, then No. 400).

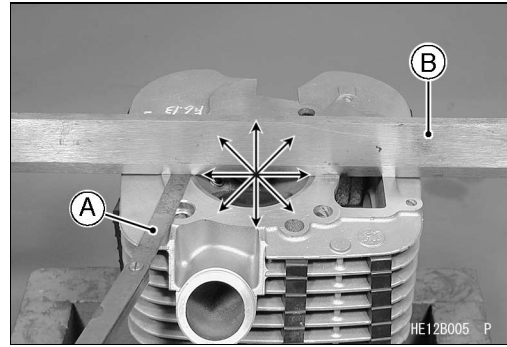

Valves, Guides, Seats, Springs, Oil Seals

Valve Clearance Inspection

- Refer to Valve Clearance Inspection in Periodic Maintenance chapter.

Valve Clearance Adjustment

- Loosen the locknut [A] and turn the adjusting screw [B] until the clearance is correct.
- Hold the adjusting screw from turning and tighten the locknut to the specified torque.

Torque - Valve Adjusting Screw Locknuts: 12 N·m (1.2 kgf·m, 104 in·lb)

- Recheck the clearance.
- ★ If the clearance is incorrect, repeat the adjustment procedure.
- ★ If the clearance is correct, perform the adjustment procedure on the other valve.

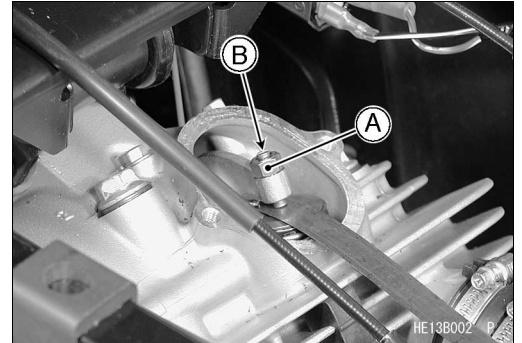

- Apply grease to the O-ring [A].
- Install the valve adjusting cap so that the "UP" mark facing upward.
- Tighten:

Torque - Valve Adjusting Cap Bolts: 8.8 N·m (0.9 kgf·m, 78 in·lb)

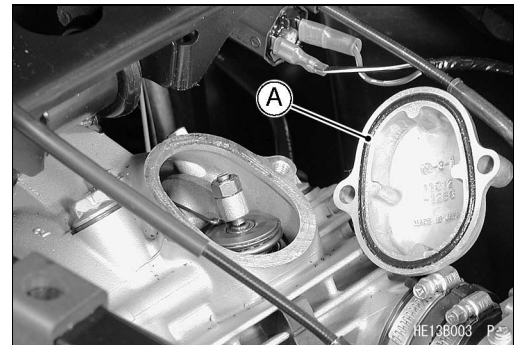

Valve Removal

- Remove:
 - Cylinder Head (see Cylinder Head Removal)
 - Camshaft (see Camshaft Removal)
 - Rocker Arms and Shafts (see Rocker Arm and Shaft Removal)
- Use the valve spring compressor assembly [A] and adapter [B] to press down the valve spring retainer.

Special Tools - Valve Spring Compressor Assembly: 57001-241
Valve Spring Compressor Adapter, $\phi 28.2$: 57001-243

- Remove the split keepers.
- Loosen the valve spring compressor and take out the valve.

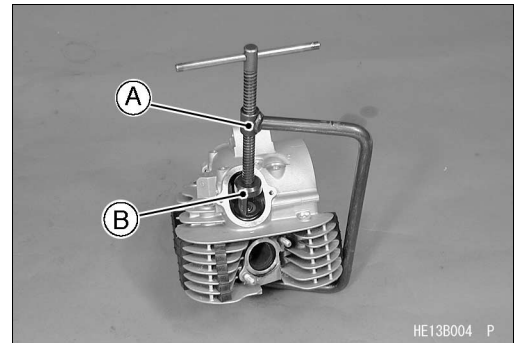

4-22 ENGINE TOP END

Valves, Guides, Seats, Springs, Oil Seals

Valve Installation

- If a new valve is to be used, check the valve-to-guide clearance.
- ★ If there is too little clearance, ream the valve guide.
- ★ If there is too much clearance, install a new valve guide.
- Check the valve seat (see Valve Seat Inspection).
- After proper valve seating has been confirmed, replace the valve stem oil seal [A].
- Apply a thin coat of molybdenum disulfide grease to the valve stem [B], and install the valve into the guide.
- Put the spring seat [C].
- Put the inner and outer springs [D] in place.
- Place the springs so that the closed coil end [E] of each spring faces down.
- Set the valve spring retainer [F] on the springs.
- Use the valve spring compressor to press down the retainer.
- Install the split keepers [G], and slowly remove the spring compressor.
- Be sure the keepers stay in place, holding the retainer down.
- Repeat the procedure for the other valve.
- Install the removed parts to the cylinder head.
- Install the cylinder head (see Cylinder Head Installation).
- Adjust the valve clearance (see Valve Clearance Inspection).

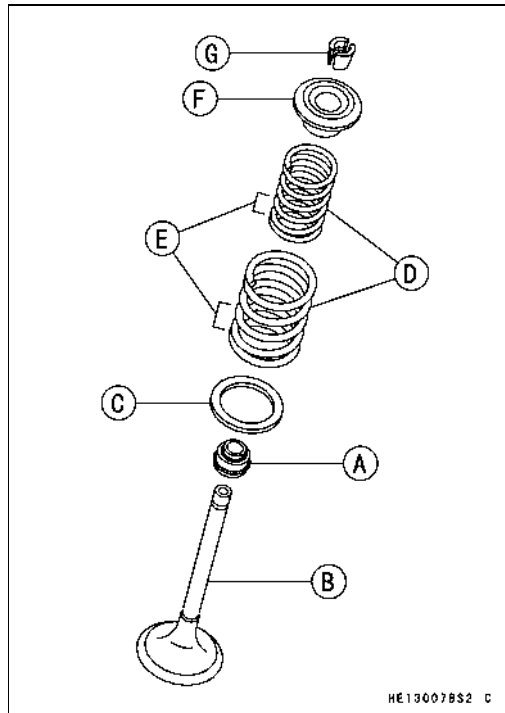

Valve Visual Inspection

- Inspect the valve head seating area [A] for erosion, nicks, and warpage.
- ★ If the valve head seating area is warped, replace the valve.
- ★ If the valve head seating area is eroded or nicked, it may be possible to repair the valve on a valve refacing machine.
- Inspect the stem [B] for obvious wear, discoloration, and stem end [C] damage.
- ★ If the stem is obviously worn or discolored, replace the valve.
- ★ If the stem end is damaged, it may be possible to repair it on a valve refacing machine.

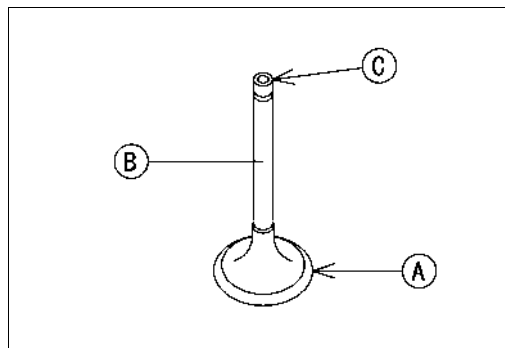

Valve Guide Removal

- Remove:
 - Valve (see Valve Removal)
 - Valve Stem Oil Seal
- Heat the area around the guide to 120 to 150°C (250 to 302°F), and hammer lightly on the valve guide arbor [A] to remove the guide from the top of the head.

Special Tool - Valve Guide Arbor, $\phi 7$: 57001-163

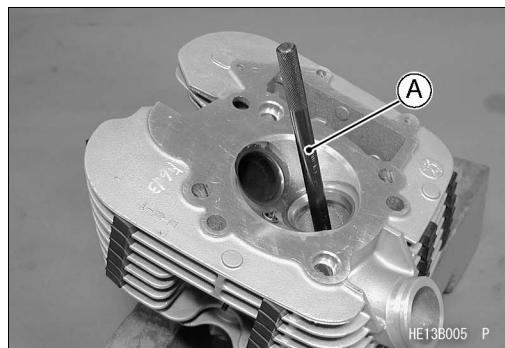

Valve Guide Installation

- Clean the valve guide hole in the cylinder head.
- Lightly oil the valve guide.
- Set the snap ring into the groove in the valve guide.
- Heat the cylinder head around the valve guide hole to 120 to 150°C (250 to 300°F).
- Use the valve guide arbor and a hammer to drive the guide into the head from the outside until the snap ring on the guide against the head.
- Allow the cylinder head to cool.
- Ream the valve guide with the valve guide reamer [A] even if the old guide is reused.

Special Tool - Valve Guide Reamer, $\phi 7$: 57001-162

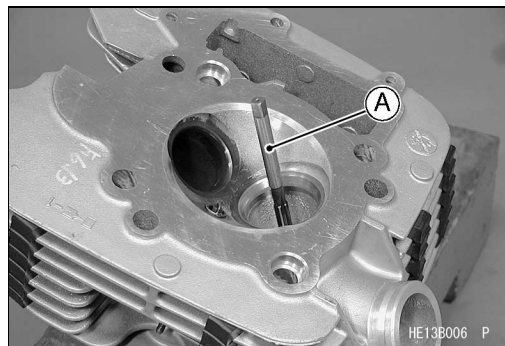

Valves, Guides, Seats, Springs, Oil Seals

Valve-to-Guide Clearance Measurement

If a small bore gauge is not available, inspect the valve guide wear by measuring the valve to valve guide clearance with the wobble method as indicated below.

- Insert a new valve [A] into the guide [B] and set a dial gauge against the stem perpendicular to it as close as possible to the cylinder head mating surface.
- Move [C] the stem back and forth to measure valve/valve guide clearance.
- Repeat the measurement in a direction at a right angle to the first.
- ★ If the reading exceeds the service limit, replace the guide.

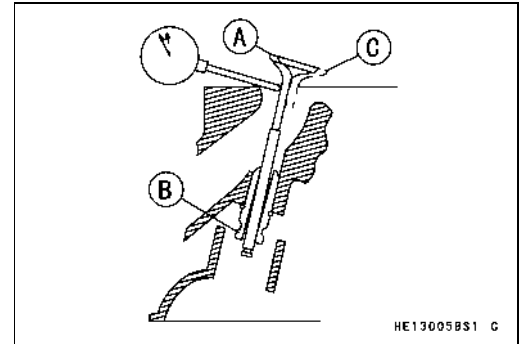

NOTE

- The reading is not actual valve/valve guide clearance because the measuring point is above the guide.

Valve/Valve Guide Clearance (Wobble Method)

	Standard	Service Limit
Exhaust	0.07 ~ 0.14 mm (0.0028 ~ 0.0055 in.)	0.30 mm (0.0118 in.)
Inlet	0.05 ~ 0.13 mm (0.0020 ~ 0.0051 in.)	0.30 mm (0.0118 in.)

Valve Seat Inspection

- Remove the valve (see Valve Removal).
- Check the valve seating surface [A] between the valve [B] and valve seat [C].
- Coat the valve seat with machinist's dye.
- Push the valve into the guide.
- Rotate the valve against the seat with a lapping tool.
- Pull the valve out, and check the seating pattern on the valve head. It must be the correct width and even all the way around.
- Measure the outside diameter [D] of the seating pattern on the valve seat.
- ★ If the outside diameter of the valve seating pattern is too large or too small, repair the seat (see Valve Seat Repair).

Valve Seating Surface Outside Diameter

Exhaust:	34.9 ~ 35.1 mm (1.374 ~ 1.382 in.)
Inlet:	39.9 ~ 40.1 mm (1.571 ~ 1.579 in.)

NOTE

- The valve stem and guide must be in good condition, or this check will not be valid.
- ★ If the valve seating pattern is not correct, repair the seat (see Valve Seat Repair).
- Measure the seat width [E] of the portion where there is no build-up carbon (white portion) of the valve seat with a vernier caliper.
- ★ If the width is too wide, too narrow or uneven, repair the seat (see Valve Seat Repair).

- [F] Good
- [G] Too Wide
- [H] Too Narrow
- [J] Uneven

Valve Seating Surface Width

Exhaust:	0.5 ~ 1.0 mm (0.02 ~ 0.04 in.)
Inlet:	0.5 ~ 1.0 mm (0.02 ~ 0.04 in.)

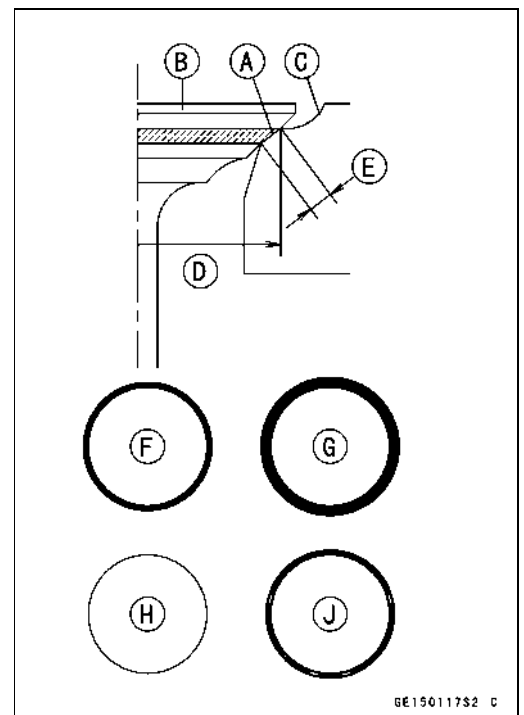

4-24 ENGINE TOP END

Valves, Guides, Seats, Springs, Oil Seals

Valve Seat Repair (Valve Lapping)

- Using the valve seat cutters [A], repair the valve seat.

Special Tools - Valve Seat Cutters:

- Exhaust Valves:** Valve Seat Cutter, 45° - ϕ 41.5: 57001-1117
Valve Seat Cutter, 32° - ϕ 38.5: 57001-1122
Valve Seat Cutter, 50° - ϕ 44: 57001-1516
- Inlet Valves:** Valve Seat Cutter, 45° - ϕ 41.5: 57001-1117
Valve Seat Cutter, 32° - ϕ 44: 57001-1515
Valve Seat Cutter, 50° - ϕ 44: 57001-1516
- Holder & Bar:** Valve Seat Cutter Holder, ϕ 7: 57001-1126 [B]
Valve Seat Cutter Holder Bar: 57001-1128 [C]

- ★ If the manufacturer's instructions are not available, use the following procedure.

Seat Cutter Operation Care:

1. This valve seat cutter is developed to grind the valve seat for repair. Therefore the cutter must not be used for other purposes than seat repair.
2. Do not drop or shock the valve seat cutter, or the diamond particles may fall off.
3. Do not fail to apply engine oil to the valve seat cutter before grinding the seat surface. Also wash off ground particles sticking to the cutter with washing oil.

NOTE

- Do not use a wire brush to remove the metal particles from the cutter. It will take off the diamond particles.
- 4. Setting the valve seat cutter holder in position, operate the cutter in one hand. Do not apply too much force to the diamond portion.

NOTE

- Prior to grinding, apply engine oil to the cutter and during the operation, wash off any ground particles sticking to the cutter with washing oil.
- 5. After use, wash it with washing oil and apply thin layer of engine oil before storing.

Marks Stamped on the Cutter:

The marks stamped on the back of the cutter [A] represent the following.

- 60°..... Cutter angle [B]
37.5 ϕ Outer diameter of cutter [C]

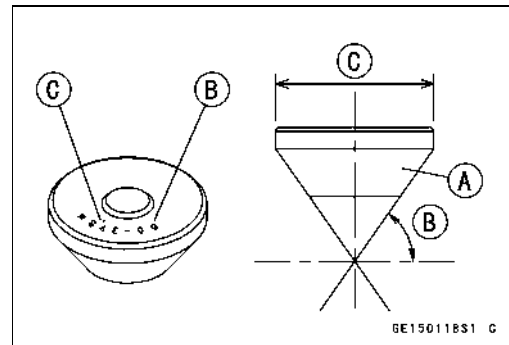
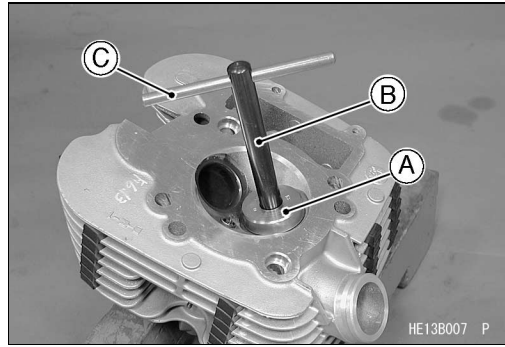

Operating Procedures:

- Clean the seat area carefully.
- Coat the seat with machinist's dye.
- Fit a 45° cutter into the holder and slide it into the valve guide.
- Press down lightly on the handle and turn it right or left. Grind the seating surface only until it is smooth.

CAUTION

Do not grind the seat too much. Overgrinding will reduce valve clearance by sinking the valve into the head. If the valve sinks too far into the head, it will be impossible to adjust the clearance, and the cylinder head must be replaced.

Valves, Guides, Seats, Springs, Oil Seals

- Widened Width [A] of engagement by machining with 45° cutter
- Ground Volume [B] by 32° cutter
- 32° [C]
- Correct Width [D]
- Ground Volume [E] by 50° cutter
- 50° [F]

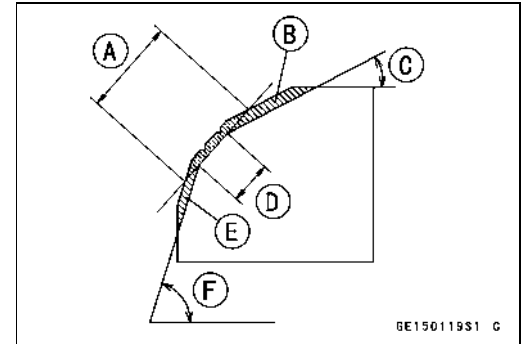

- Measure the outside diameter of the seating surface with a vernier caliper.
- ★ If the outside diameter of the seating surface is too small, repeat the 45° grind [A] until the diameter is within the specified range.
- Original Seating Surface [B]

NOTE

- Remove all pittings of flaws from 45° ground surface.
 - After grinding with 45° cutter, apply thin coat of machinist's dye to seating surface. This makes seating surface distinct and 32° and 50° grinding operation easier.
 - When the valve guide is replaced, be sure to grind with 45° cutter for centering and good contact.
- ★ If the outside diameter [A] of the seating surface is too large, make the 32° grind described below.
 - ★ If the outside diameter of the seating surface is within the specified range, measure the seat width as described below.
 - Grind the seat at a 32° angle [B] until the seat O.D. is within the specified range.
 - To make the 32° grind, fit a 32° cutter into the holder, and slide it into the valve guide.
 - Turn the holder one turn at a time while pressing down very lightly. Check the seat after each turn.

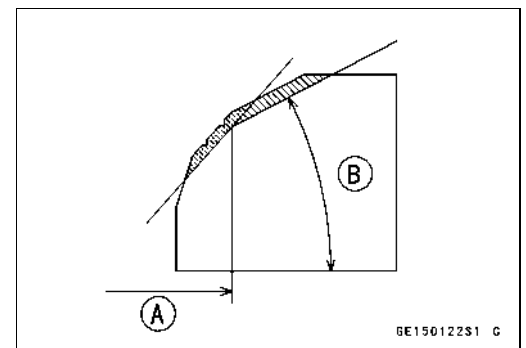
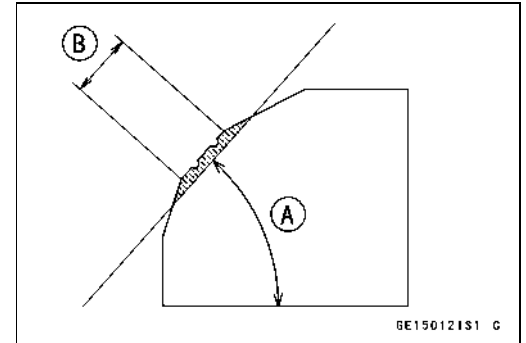

CAUTION

The 32° cutter removes material very quickly. Check the seat outside diameter frequently to prevent overgrinding.

- After making the 32° grind, return to the seat O.D. measurement step above.
- To measure the seat width, use a vernier caliper to measure the width of the 45° angle portion of the seat at several places around the seat.
- ★ If the seat width is too narrow, repeat the 45° grind until the seat is slightly too wide, and then return to the seat O.D. measurement step above.
- ★ If the seat width is too wide, make the 50° [A] grind described below.
- ★ If the seat width is within the specified range, lap the valve to the seat as described below.
- Grind the seat at a 50° angle until the seat width is within the specified range.
- To make the 50° grind, fit 50° cutter into the holder, and slide it into the valve guide.
- Turn the holder, while pressing down lightly.
- After making the 50° grind, return to the seat width measurement step above.
- Correct Width [B]

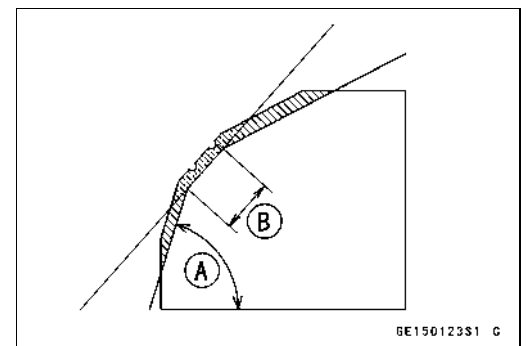

4-26 ENGINE TOP END

Valves, Guides, Seats, Springs, Oil Seals

- Lap the valve to the seat, once the seat width and O.D. are within the ranges specified above.
- Put a little coarse grinding compound on the face of the valve in a number of places around the valve head.
- Spin the valve against the seat until the grinding compound produces a smooth, matched surface on both the seat and the valve.
- Repeat the process with a fine grinding compound.
 - [A] Lapper
 - [B] Valve Seat
 - [C] Valve
- The seating area should be marked about in the middle of the valve face.
- ★ If the seat area is not in the right place on the valve, check to be sure the valve is the correct part. If it is, it may have been refaced too much; replace it.
- Be sure to remove all grinding compound before assembly.
- When the engine is assembled, be sure to adjust the valve clearance (see Valve Clearance Adjustment).

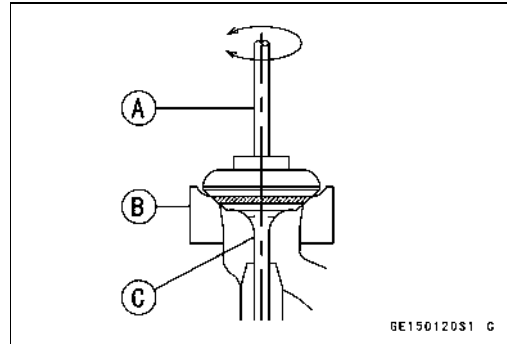

Valves, Guides, Seats, Springs, Oil Seals

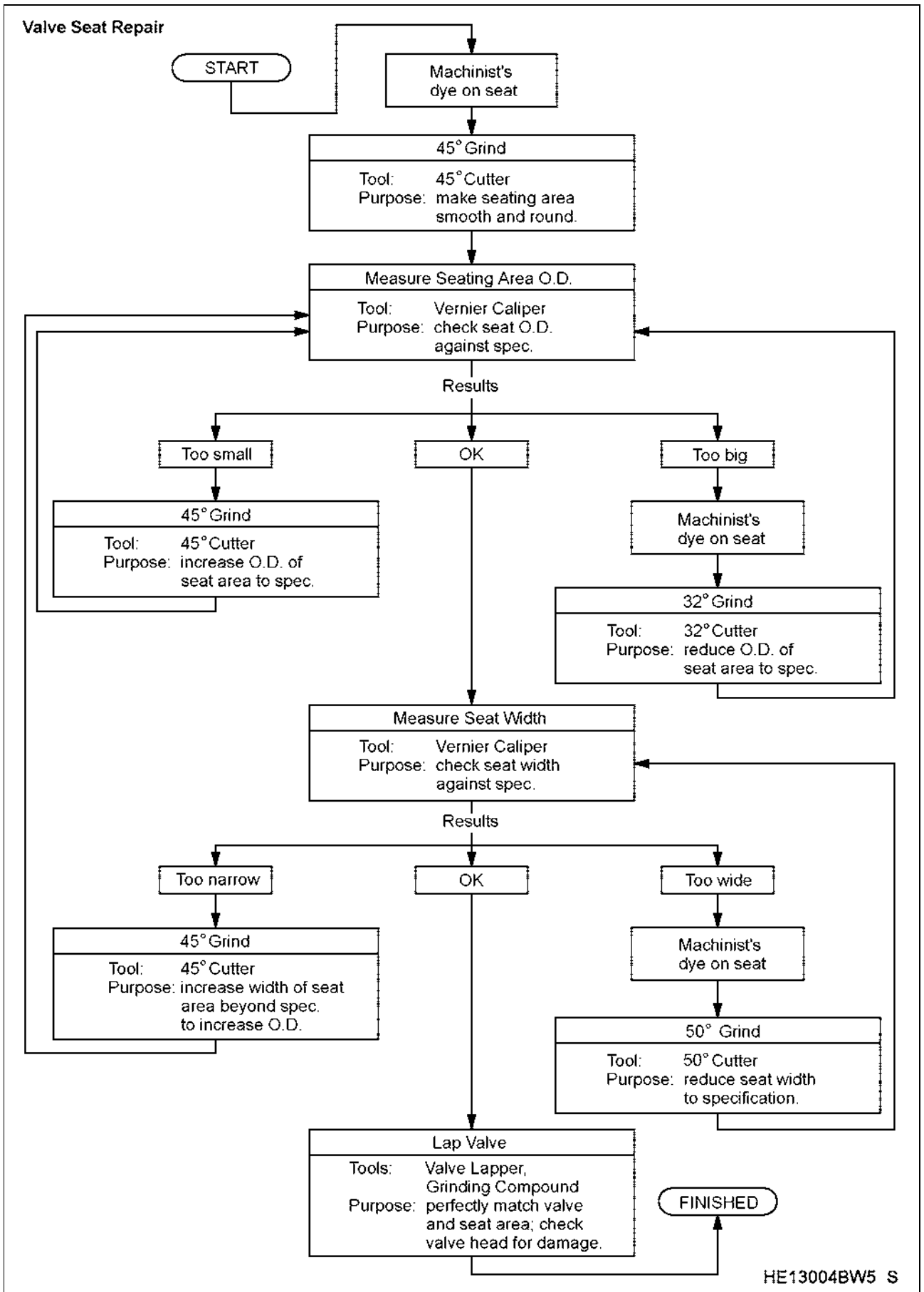

4-28 ENGINE TOP END

Cylinder and Piston

Cylinder Removal

- Remove:
 - Cylinder Head (see Cylinder Head Removal)
 - Front Chain Guide [A]
- Lift off the cylinder [B], and remove the cylinder base gasket. If necessary, tap lightly around the base of the cylinder with a plastic mallet, taking care not to damage the cylinder.
- Immediately stuff a clean cloth around the piston to prevent parts or dirt from falling into the crankcase.

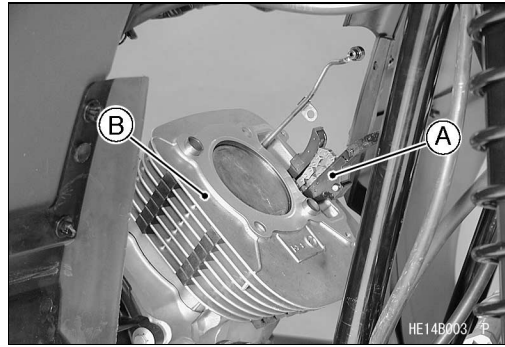

Cylinder Installation

NOTE

- If a new cylinder is installed, be sure to check piston/cylinder clearance (see Piston/Cylinder Clearance).
- Clean any remains of the old cylinder base gasket from the bottom of the cylinder and the top of the crankcase.
- Install:
 - Dowel Pins [A]
 - New Cylinder Base Gasket [B]
- The arrow [A] on the piston head must point toward the front of the engine.
- The piston ring openings must be positioned as shown. The openings of the oil ring steel rails must be about $30^{\circ} \sim 40^{\circ}$ [B] of angle from the opening of the top ring.
 - Top Ring [C]
 - Second Ring [D]
 - Oil Ring Expander [E]
 - Oil Ring Steel Rails [F]
- Apply engine oil to the cylinder bore and piston rings.
- The rear camshaft chain guide also fit inside the tunnel.
- Fit the cylinder down over the piston and rings.
- Hold the rings into their groove with your fingers so that the cylinder does not catch on them.
- Push the cylinder down solidly against the crankcase.

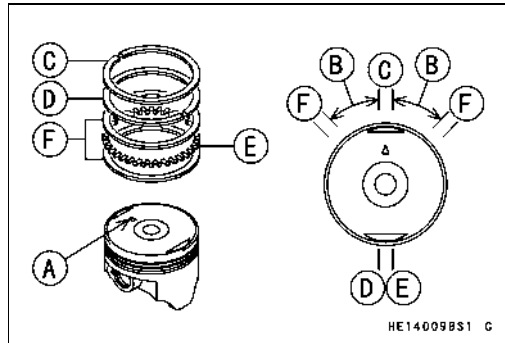
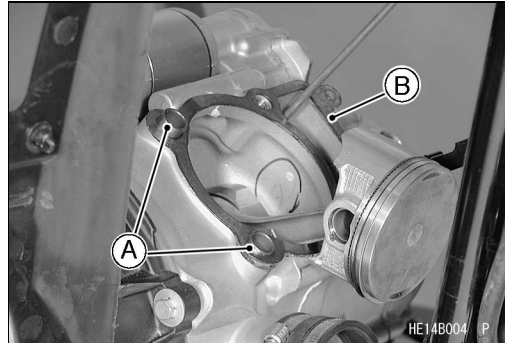

Cylinder and Piston

Cylinder Assembly

- Insert the rubber dampers [A] in the fin grooves.
- [B] Front Side
- [C] Right Side
- [D] Rear Side
- [E] 22 mm (0.87 in.)
- [F] 21 mm (0.83 in.)
- [G] 31 mm (1.22 in.)

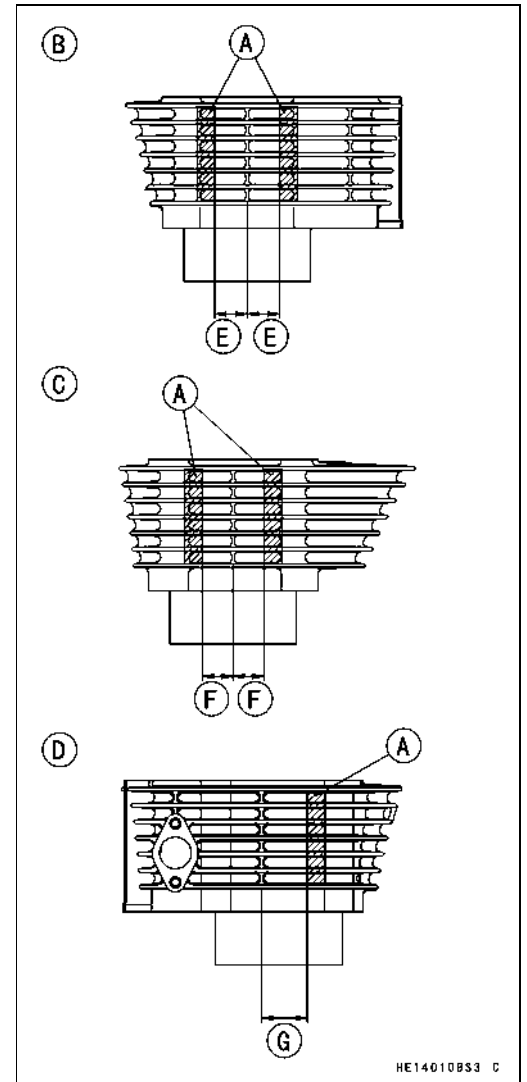

Piston Removal

- Remove the cylinder (see Cylinder Removal).
- Place a clean cloth under the piston, remove the one of the piston pin snap rings [A].

CAUTION

Do not reuse snap rings, as removal weakens and deforms them. They could fall out and score the cylinder wall.

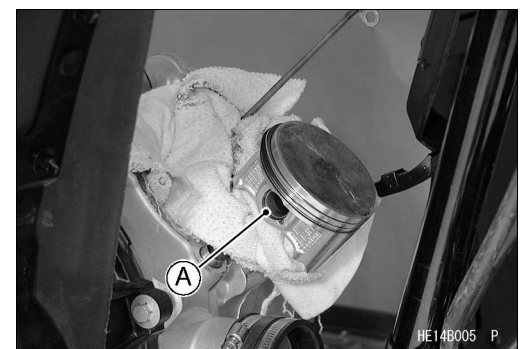

- Push out the piston pin, and remove the piston.
 - If necessary, use the piston pin puller assembly [A].
- Special Tools - Piston Pin Puller Assembly: 57001-910**
Piston Pin Puller Adapter [B]: 57001-1211

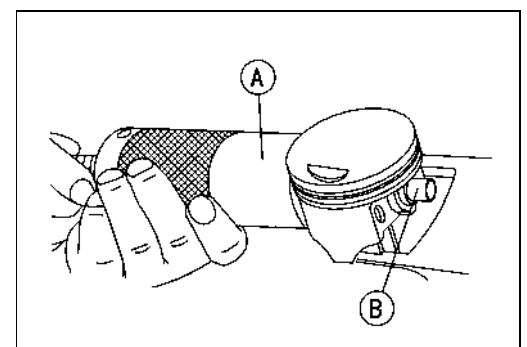

4-30 ENGINE TOP END

Cylinder and Piston

- Remove the top and second piston rings [A].
- Spread the ring open with your thumbs.
- Push up on the opposite side with your fingers.
- Remove the oil ring upper and lower steel rails.
- Spread the rail open with your thumbs.
- Push up on the opposite side with your fingers.
- Remove the oil ring expander.

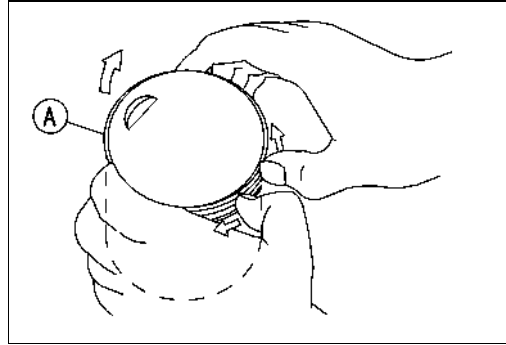

Piston Installation

NOTE

- If a new piston is used, check piston to cylinder clearance (see *Piston/Cylinder Clearance*), and use new piston rings.
- The oil ring rails have no “top” or “bottom”.
- Install the oil ring expander [A] in the bottom piston ring groove so the ends [B] butt together.
- Install the oil ring steel rails, one above the expander and one below it.
- Spread the rail with your thumbs, but only enough to fit the rail over the piston.
- Release the rail into the bottom piston ring groove.
- Do not mix up the top ring and second ring.
- Install the second ring [A] so that the “RN” mark [B] faces up.
- Install the top ring [C] so that the “R” mark [D] faces up.

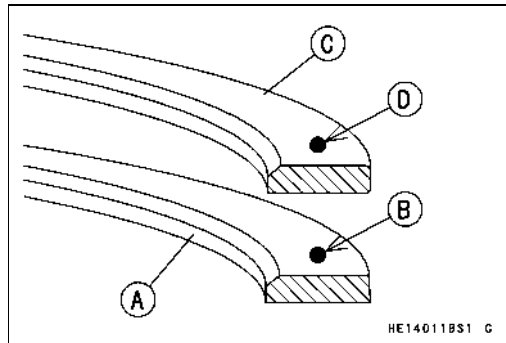
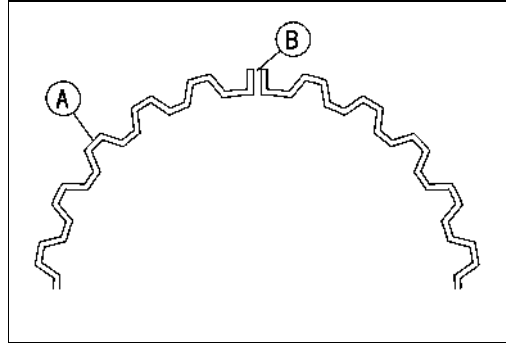

HE14011BS1 C

- Install the piston pin [A].
- Oil the piston pin lightly and slide it through the side of the piston without a snap ring.
- Hold the piston in position over the connecting rod, with the arrow [B] pointing forward, and slide the piston pin the rest of the way through the connecting rod and piston.
- Fit a new piston pin snap ring into the side of the piston so that the ring opening does not coincide with the slit of the piston pin hole.

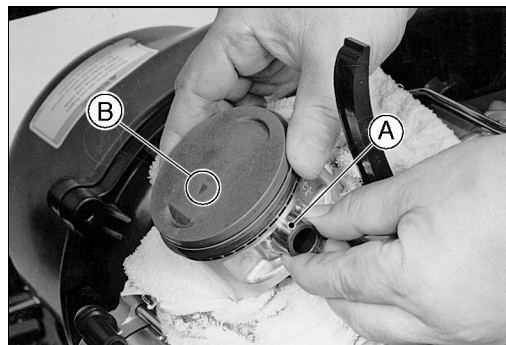

Cylinder and Piston

Cylinder/Piston Wear

- Since there is a difference in cylinder wear in different direction, take a side-to-side and a front-to-back measurement at each of the 3 locations (total of 6 measurements) shown in the figure.
- ★ If any of the cylinder inside diameter measurements exceeds the service limit, replace the cylinder.
 - 20 mm (0.79 in.) [A]
 - 40 mm (1.57 in.) [B]
 - 10 mm (0.39 in.) [C]

Cylinder Inside Diameter

- Standard:** 80.000 ~ 80.012 mm (3.1496 ~ 3.1501 in.), and less than 0.01 mm (0.0004 in.) difference between any two measurements
- Service Limit:** 80.10 mm (3.154 in.), or more than 0.05 mm (0.0020 in.) difference between any two measurements

- Measure the piston diameter [A] of each piston 5 mm (0.20 in.) [B] up from the bottom of the piston at a right angle to the direction of the piston pin.

Piston Diameter

- Standard:** 79.952 ~ 79.967 mm (3.1477 ~ 3.1483 in.)
- Service Limit:** 79.80 mm (3.142 in.)

- ★ If the piston diameter is less than the service limit, replace it.

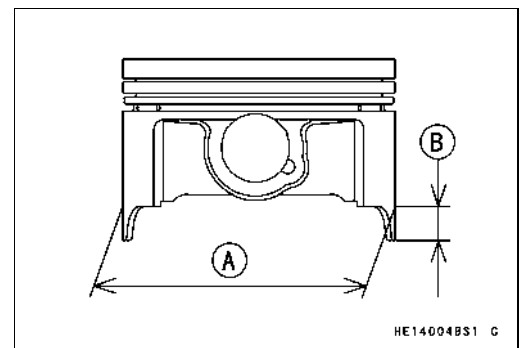
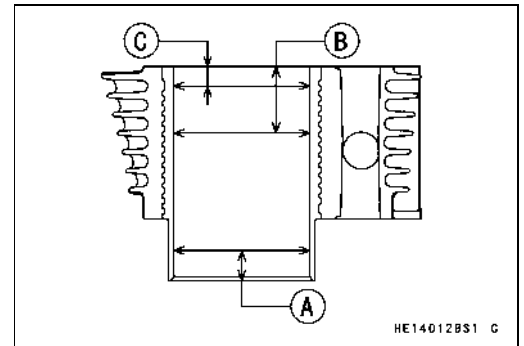

Piston/Cylinder Clearance

- Subtract the piston diameter from the cylinder inside diameter to get the piston/cylinder clearance.

Piston/Cylinder Clearance

- Standard:** 0.033 ~ 0.060 mm (0.0013 ~ 0.0024 in.)

Piston Ring and Ring Groove Wear

- Check for uneven groove wear by inspecting the ring seating.
- ★ The rings should fit perfectly parallel to groove surfaces. If not, replace the piston and all the piston rings.
- With the piston rings in their grooves, make several measurements with a thickness gauge [A] to determine piston ring/groove clearance.

Piston Ring/Groove Clearance

	Standard	Service Limit
Top:	0.04 ~ 0.08 mm (0.0016 ~ 0.0032 in.)	0.18 mm (0.0071 in.)
Second:	0.03 ~ 0.07 mm (0.0012 ~ 0.0028 in.)	0.17 mm (0.0067 in.)

- ★ If the piston ring groove clearance is greater than the service limit, measure the ring thickness and groove width as follows to decide whether to replace the rings, the piston or both.

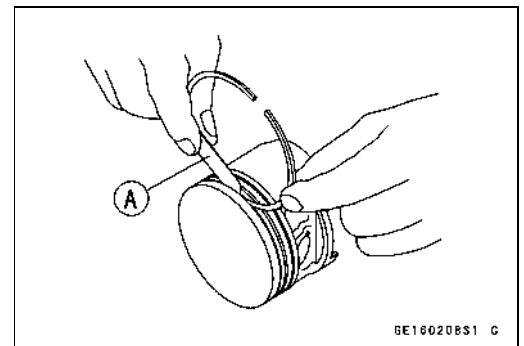

4-32 ENGINE TOP END

Cylinder and Piston

Piston Ring Groove Width

- Measure the piston ring groove width.
- Use a vernier caliper at several points around the piston.

Piston Ring Groove Width

	Standard	Service Limit
Top:	1.03 ~ 1.05 mm (0.0405 ~ 0.0413 in.)	1.13 mm (0.0445 in.)
Second:	1.02 ~ 1.04 mm (0.0402 ~ 0.0409 in.)	1.12 mm (0.0441 in.)

- ★ If the width of any of the two grooves is wider than the service limit at any point, replace the piston.

Piston Ring Thickness

- Measure the piston ring thickness.
- Use a micrometer to measure at several points around the ring.

Piston Ring Thickness

	Standard	Service Limit
Top:	0.97 ~ 0.99 mm (0.0382 ~ 0.0390 in.)	0.90 mm (0.035 in.)
Second:	0.97 ~ 0.99 mm (0.0382 ~ 0.0390 in.)	0.90 mm (0.035 in.)

- ★ If any of the measurements is less than the service limit on either of the rings, replace all the rings.

NOTE

- When using new rings in a used piston, check for uneven groove wear. The rings should fit perfect parallel to the groove sides. If not, replace the piston.

Piston Ring End Gap Measurement

- Place the piston ring inside the cylinder, using the piston to locate the ring squarely in place. Set it close to the bottom of the cylinder, where cylinder wear is low.
- Measure the gap [A] between the ends of the ring with a thickness gauge, where cylinder wear is low.

Piston Ring End Gap

	Standard	Service Limit
Top:	0.20 ~ 0.30 mm (0.0079 ~ 0.0118 in.)	0.6 mm (0.0236 in.)
Second:	0.30 ~ 0.45 mm (0.0118 ~ 0.0177 in.)	0.8 mm (0.0315 in.)
Oil:	0.20 ~ 0.70 mm (0.0079 ~ 0.0276 in.)	1.0 mm (0.0394 in.)

- ★ If the end gap of either ring is greater than the service limit, replace all the rings.

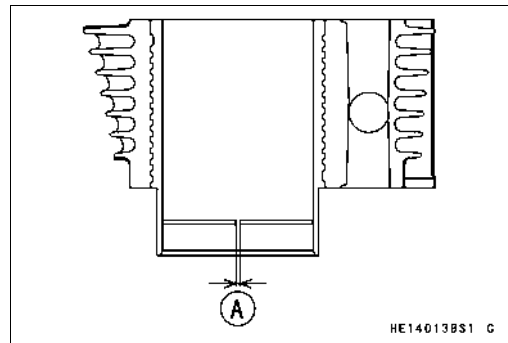

Exhaust System

This vehicle is equipped with a spark arrester approved for off-road use by the U.S. Forest Service. It must be properly maintained to ensure its efficiency. In accordance with the Periodic Maintenance Chart, clean the spark arrester.

Spark Arrester Cleaning

- Refer to Spark Arrester Cleaning in Periodic Maintenance chapter.

Muffler Removal

- Loosen the muffler clamp bolt [A] until the clamp turns freely on the muffler.
- Remove the muffler mounting bolts [B].
- Remove the muffler [C] from the rear of the frame.

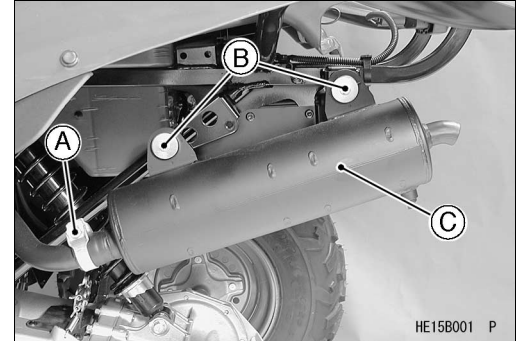

Exhaust Pipe Removal

- Remove:
 - Left Front Wheel (see Wheels/Tires chapter)
 - Front Left Inner Cover (see Frame chapter)
 - Exhaust Pipe Cover (see Frame chapter)
 - Muffler (see Muffler Removal)
 - Exhaust Pipe Nuts [A]
 - Exhaust Pipe [B]
 - Gasket

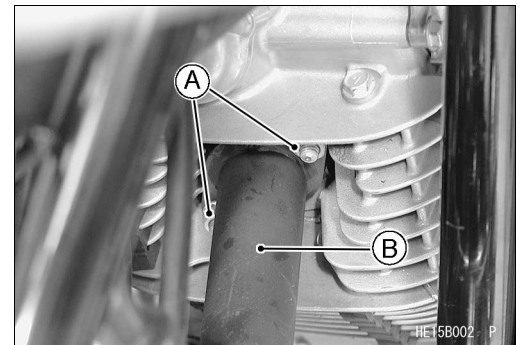

Exhaust Pipe and Muffler Installation

- Replace the exhaust pipe holder gasket [A] and clamp gasket [B] with new ones.
- Install:
 - Exhaust Pipe [C] and Clamp [D]
 - Muffler [E] and Dampers [F] and Collars [G]
 - Plane Washers [H] and Spring Washers [I]
- Tighten:
 - Torque - Muffler Mounting Bolts [J]: 26 N·m (2.7 kgf·m, 20 ft·lb)**

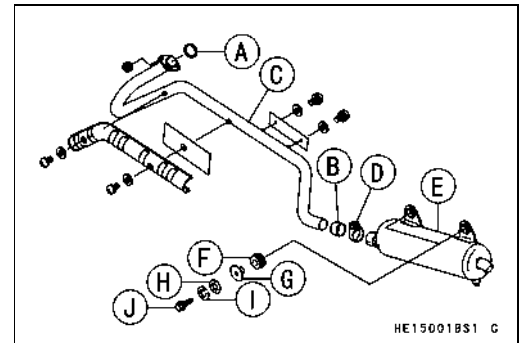

Exhaust System Inspection

- Before removing the exhaust system, check for signs of leakage at the exhaust pipe gasket in the cylinder head and at the muffler clamp.
- ★ If there are signs of leakage around the exhaust pipe gasket, it should be replaced. If the muffler-to-exhaust pipe joint leaks, tighten the clamp.
- Remove the exhaust pipe and muffler (see Exhaust Pipe and Muffler Removal).
- Inspect the gasket for damage and signs of leakage.
- ★ If the gasket is damaged or has been leaking, replace it.
- Check the exhaust pipe and muffler for dents, cracks, rust and holes.
- ★ If the exhaust pipe or muffler is damaged or has holes, it should be replaced for best performance and least noise.

Converter System

Table of Contents

- Exploded View.....5-2
- Specifications.....5-6
- Torque Converter.....5-7
 - Torque Converter Cover Removal.....5-7
 - Torque Converter Cover Installation.....5-7
 - Torque Converter Cover Disassembly.....5-8
 - Actuator Lever (Engine Brake Control Lever) Assembly Inspection.....5-8
 - Torque Converter Cover Assembly.....5-8
- Drive Belt.....5-10
 - Drive Belt Removal.....5-10
 - Drive Belt Installation.....5-10
 - Drive Belt Deflection Inspection.....5-10
 - Drive Belt Deflection Adjustment.....5-10
 - Drive Belt Inspection.....5-10
- Drive Pulley.....5-11
 - Drive Pulley Removal.....5-11
 - Drive Pulley Disassembly.....5-11
 - Drive Pulley Inspection.....5-12
 - Spider Shoe Side Clearance Adjustment.....5-14
 - Drive Pulley Assembly.....5-15
 - Drive Pulley Installation.....5-16
- Driven Pulley.....5-18
 - Driven Pulley Removal.....5-18
 - Driven Pulley Disassembly.....5-18
 - Driven Pulley Inspection.....5-19
 - Driven Pulley Assembly.....5-20
 - Driven Pulley Installation.....5-22
- High Altitude Setting Information.....5-23
 - Specifications.....5-23

5-2 CONVERTER SYSTEM

Exploded View

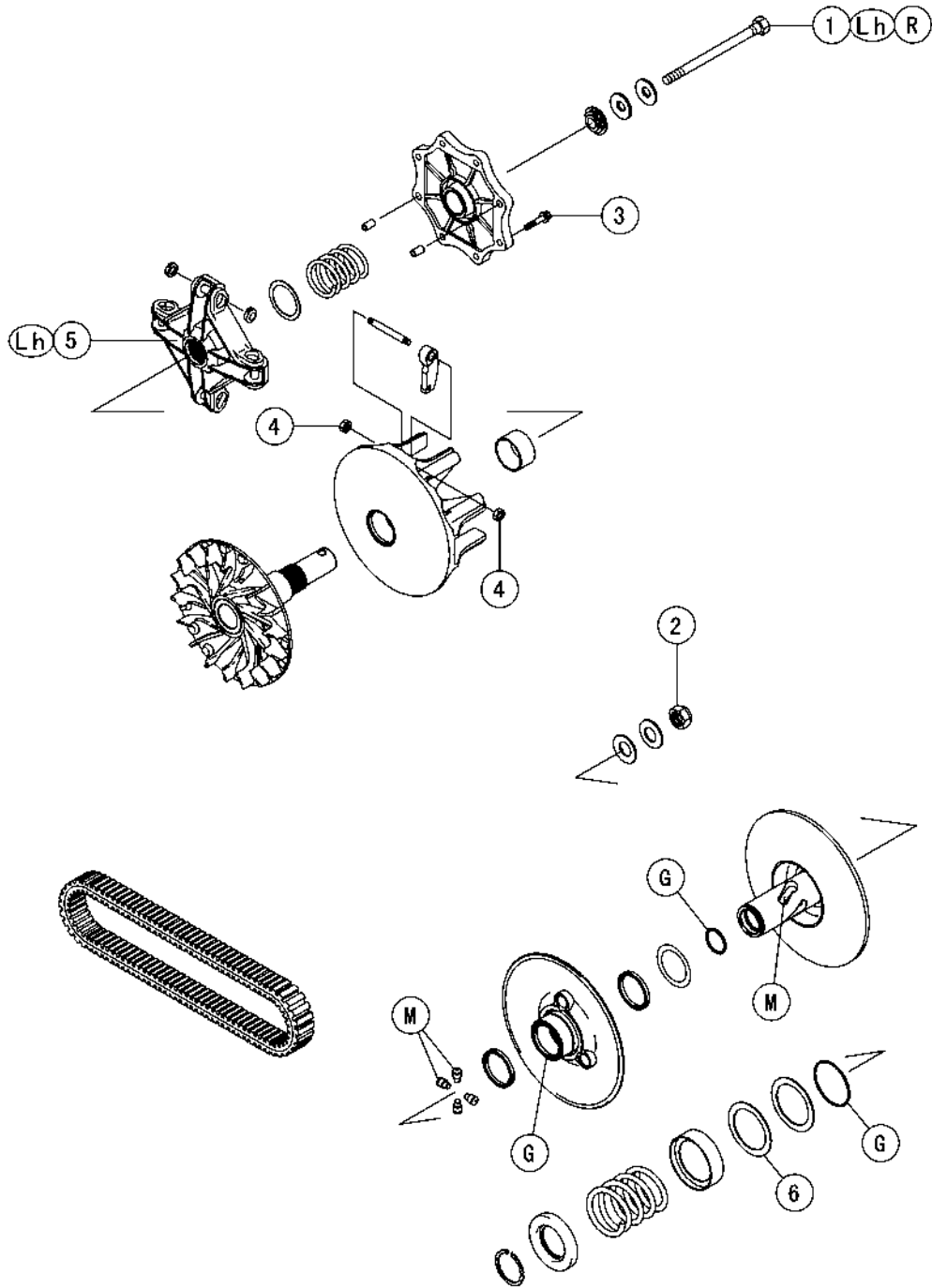

CONVERTER SYSTEM 5-3

Exploded View

No.	Fastener	Torque			Remarks
		N·m	kgf·m	ft·lb	
1	Drive Pulley Bolt	93	9.5	69	R, Lh
2	Driven Pulley Nut	93	9.5	69	
3	Drive Pulley Cover Bolts	13	1.3	113 in·lb	
4	Ramp Weight Nuts	6.9	0.7	61 in·lb	
5	Spider	275	28	203	Lh

6: Spacer for High Altitude Setting

G: Apply grease for oil seal and O-ring.

M: Apply molybdenum disulfide grease.

Lh: Left-hand Threads

R: Replacement Parts

5-4 CONVERTER SYSTEM

Exploded View

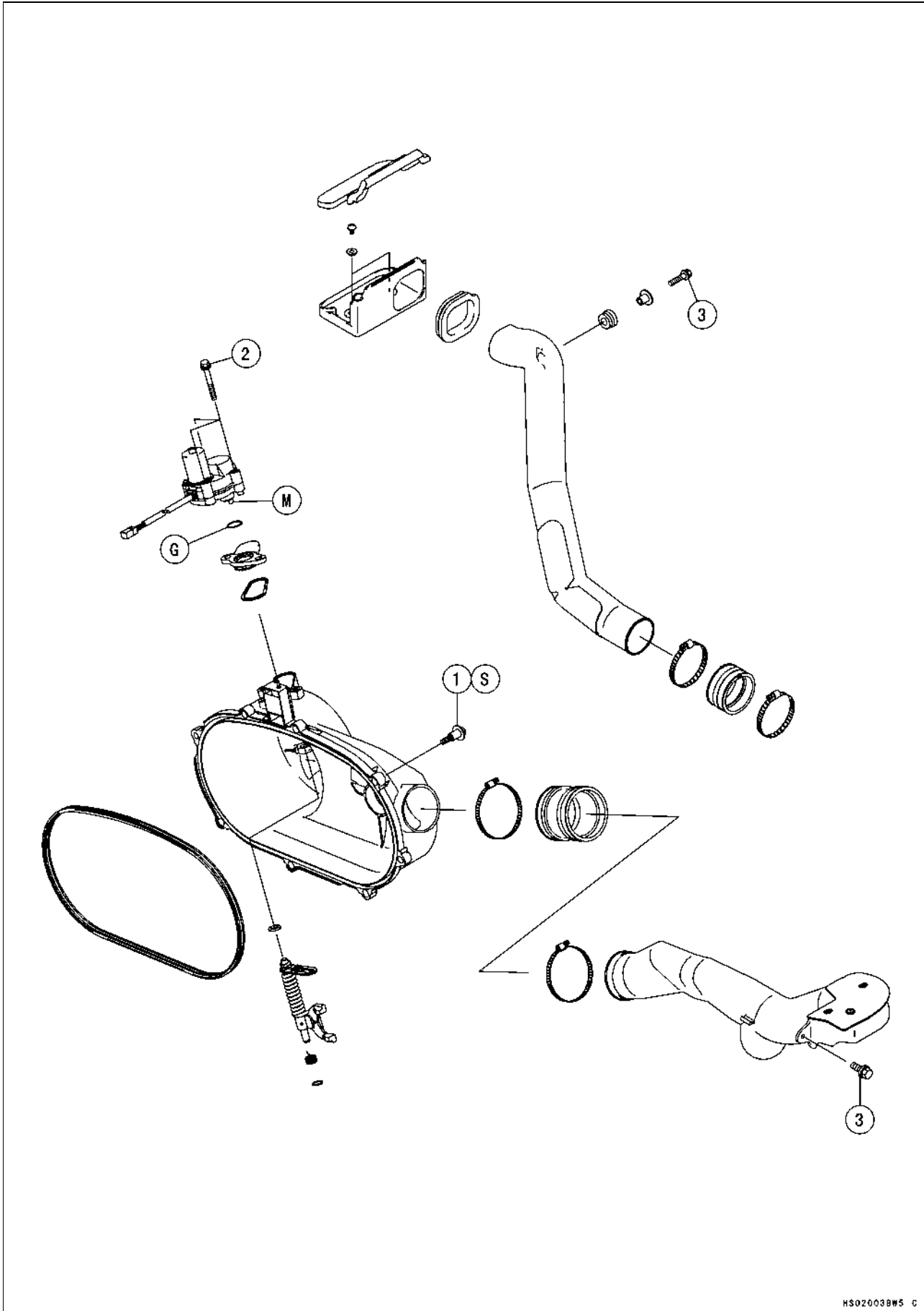

CONVERTER SYSTEM 5-5

Exploded View

No.	Fastener	Torque			Remarks
		N·m	kgf·m	ft·lb	
1	Converter Cover Bolts	8.8	0.9	78 in·lb	S
2	Engine Brake Actuator Mounting Bolts	8.8	0.9	78 in·lb	
3	Converter Air Duct Bolts	8.8	0.9	78 in·lb	

- S: Follow the specific tightening sequence.
- G: Apply grease for oil seal and O-ring.
- M: Apply molybdenum disulfide grease.

5-6 CONVERTER SYSTEM

Specifications

Item	Standard	Service Limit
Torque Converter:		
Actuator lever guide shoe wear	---	6 mm (0.24 in.)
Drive Belt:		
Belt Deflection	20 ~ 27 mm (0.79 ~ 1.06 in.)	---
Belt Width	29.8 ~ 31.0 mm (1.17 ~ 1.22 in.)	29.4 mm (1.16 in.)
Drive Pulley:		
Cover bushing inside diameter	27.985 ~ 28.085 mm (1.1018 ~ 1.1057 in.)	28.12 mm (1.107 in.)
Sheave bushing inside diameter	37.985 ~ 38.085 mm (1.4955 ~ 1.4994 in.)	38.12 mm (1.501 in.)
Shoe side clearance	0.15 ~ 0.30 mm (0.0059 ~ 0.0118 in.)	---
Spring free length	60 mm (2.36 in.)	---
Driven Pulley:		
Sheave bushing inside diameter	39.994 ~ 40.104 mm (1.5746 ~ 1.5789 in.)	40.13 mm (1.580 in.)
Spring free length	75.1 mm (2.96 in.)	---

Special Tools - Circlip Pliers: 57001-154

Flywheel & Pulley Holder: 57001-1343

Drive & Driven Pulley Holder: 57001-1412

Drive Pulley Puller Bolt: 57001-1429

Pulley Holder Attachment: 57001-1472

Drive & Driven Pulley Holder: 57001-1473

Drive Pulley Wrench: 57001-1474

Spring Holder Set: 57001-1483

Drive Pulley Measurement Tool: 57001-1498

Actuator Lever Measurement Tool: 57001-1499

Drive Pulley Holder: 57001-1520

Torque Converter

⚠ WARNING

Excessive imbalance or operating rpm could cause torque converter pulley failure resulting in severe injury or death. The pulleys of the belt drive torque converter are precision balanced components designed to operate within certain rpm limits. Disassembly/assembly and servicing procedures of the pulley assemblies must be followed closely. Modifications to the engine or pulleys that increase rpm may cause failure.

CAUTION

Do not turn the ignition switch OFF position from ON position, while the torque converter cover is removed. If it is done, the learning control of Engine Brake Control system works and the engine brake actuator works an error operation.

NOTE

- If the drive belt failure detection system is activated by abnormal belt, the drive belt failure detection switch is damaged. Make sure to replace the torque converter cover.

Torque Converter Cover Removal

- Turn the ignition switch OFF.

NOTE

- If the drive failure detection switch lead connector is disconnected when the ignition switch is in the ON position, the drive Belt Failure Detection System is activated in the drive belt failure mode. For resetting the failure mode, the drive belt failure mode clearing procedure must be done (see LED Indicator section in Electrical System chapter).
- Disconnect:
 - Drive Belt Failure Detection Switch Lead Connector [A]
 - Engine Brake Actuator Lead Connector [B]
- ★ If the disconnecting is difficult, remove the fuel tank cover (see Frame chapter).
- Remove:
 - Clamp [A]
 - Air Duct [B]
 - Torque Converter Cover Bolts [C]
 - Torque Converter Cover [D]

Torque Converter Cover Installation

- Check the actuator lever assembly installation length (see Torque Converter Cover Assembly).
- Fit the trim seal into the converter cover.
- Position point [A] as shown.

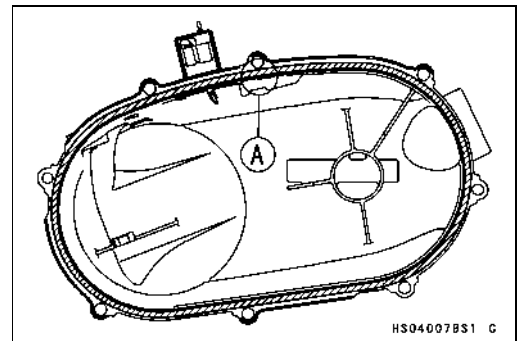
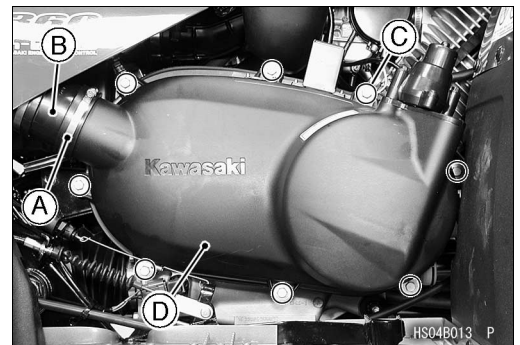
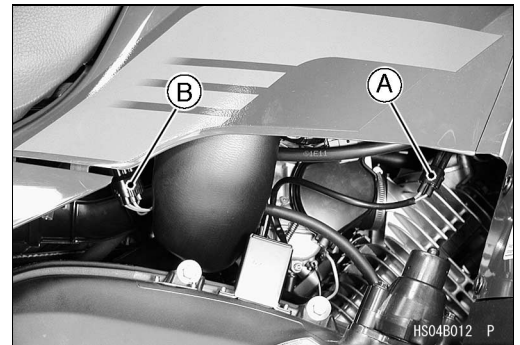

5-8 CONVERTER SYSTEM

Torque Converter

- Check:
 - Drive Belt Failure Detection Switch (see Switch Inspection section in Electric System chapter)
- Set the switch lever [A] to the ON mark side [B].

NOTE

- The failure detection system is activated when the switch is in the ON position. This is the normal running mode. Engine rpm is limited when the switch is in the OFF position.

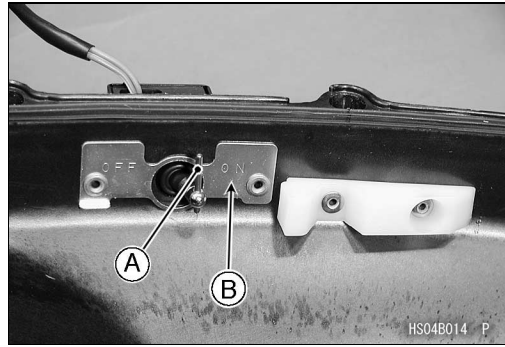

- Tighten the No. 3 bolt temporarily.
- Tighten the No.1 and No.2 bolts temporarily.
- Press the cover toward the arrow [A], and then tighten the cover bolts following the tightening sequence as shown.

Torque - Converter Cover Bolts: 8.8 N·m (0.9 kgf·m, 78 in·lb)

[B] Clamp

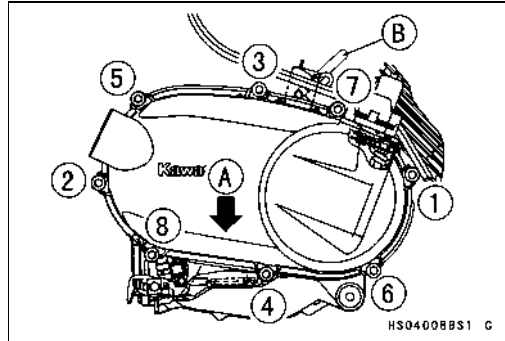

Torque Converter Cover Disassembly

- Remove:
 - Torque Converter Cover (see Torque Converter Cover Removal)
 - Engine Brake Actuator (see Electrical System chapter)
 - Circlip [A]
 - Spring [B]
 - Actuator Lever Assembly [C]

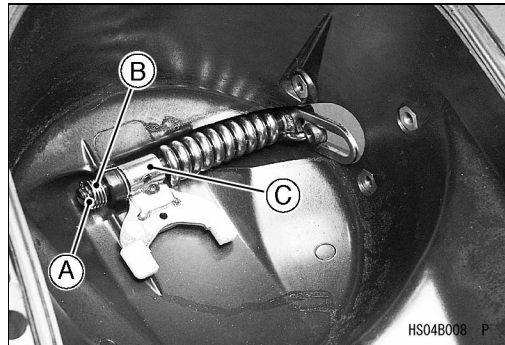

Actuator Lever (Engine Brake Control Lever) Assembly Inspection

- Refer to Actuator Lever (Engine Brake Control Lever) Assembly Inspection in Periodic Maintenance chapter.

Torque Converter Cover Assembly

- Install:
 - New Circlip
 - Spring
 - Actuator Lever Assembly
 - Engine Brake Actuator (see Electrical System chapter)
- Measure the installation length [A] of the actuator lever assembly between the cover end [B] and resin tips [C] on the actuator lever assembly as follows:

Actuator Lever Assembly Installation Length

Standard: 149.33 ~ 150.47 mm (5.879 ~ 5.924 in.)

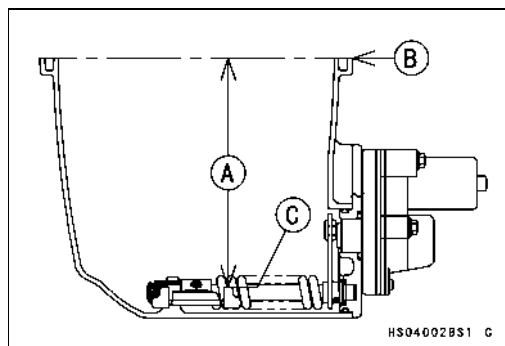

Torque Converter

- Install the actuator lever measurement tool (plate [A] and rods [B]) on the torque converter cover [C] and tighten the two cover bolts.

Special Tool - Actuator Lever Measurement Tool: 57001-1499

- Set the rod ends on the resin tips [D].
- Measure the recess length [E] between the plate and rods with Vernier calipers [F] or depth gauge.

Measurement Length [E]

Standard: 1.33 ~ 2.47 mm (0.052 ~ 0.097 in.)

- ★ If the measurement is 1.33 mm (0.052 in.) or less, use the actuator lever assembly (13236-1385) of yellow paint.
- ★ If the measurement is more than 2.47 mm (0.097 in.), use the actuator lever assembly (13236-1386) of green paint.
- ★ If the length is not within the specified length after the actuator lever assembly is replaced, replace the torque converter cover, and install the actuator lever assembly (13236-1387).

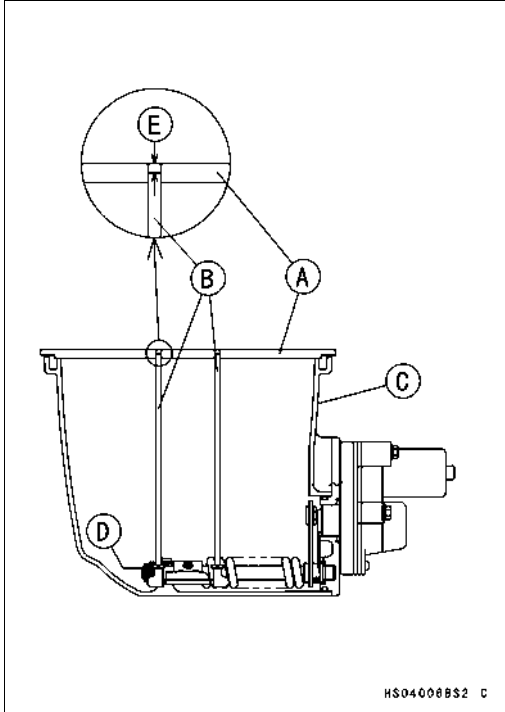
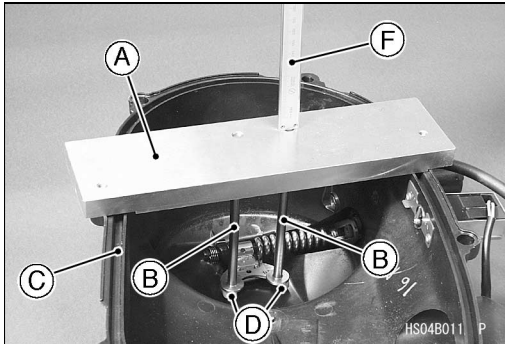

HS04006852 C

Actuator Lever Assemblies

Part Number	Paint Color [A]	Length [B]
13236-1385	Yellow	0.4 ± 0.1 mm (0.016 ± 0.004 in.)
13236-1387	None	1.0 ± 0.1 mm (0.039 ± 0.004 in.)
13236-1386	Green	1.6 ± 0.1 mm (0.063 ± 0.004 in.)

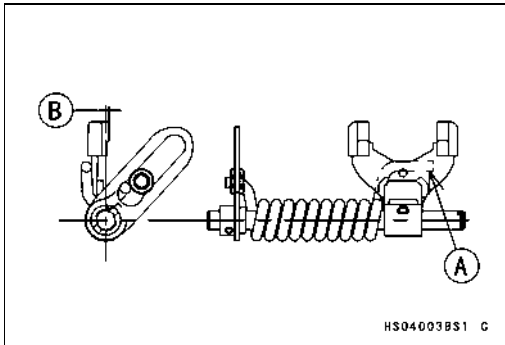

HS04003851 C

5-10 CONVERTER SYSTEM

Drive Belt

Drive Belt Removal

- Remove the drive pulley [A] (see Drive Pulley Removal).

NOTE

- Before removing, observe the direction the belt's printed information [B] (such as manufacturer's name and arrow marks) is facing so that it may be reinstalled on the pulleys to rotate in the same direction as originally installed.
- Lift the drive belt [C] off the driven pulley [D].

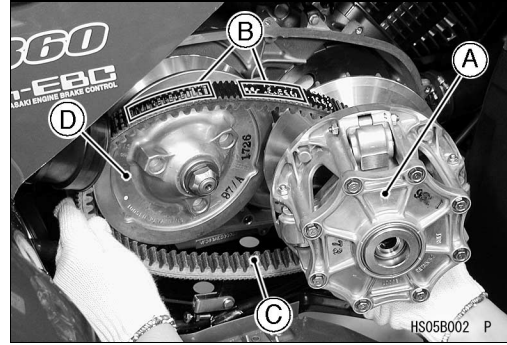

Drive Belt Installation

NOTE

- Be sure the printed information faces the same direction so the belt rotates in the same direction as originally installed. When installing a new belt, install it so the printed information [A] can be read from beside the vehicle.
 - Installation is basically the reverse of removal.
 - Loop the belt over the driven pulley.
 - Install the drive pulley (see Drive Pulley Installation).
-
- Put the transmission in neutral, and rotate the driven pulley to allow the belt to return to the top [A] of the sheaves, before measuring belt deflection.

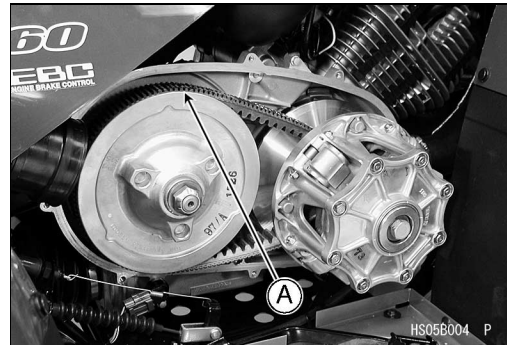
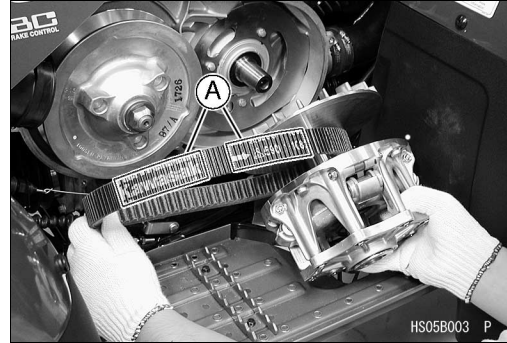

Drive Belt Deflection Inspection

- Refer to Drive Belt Deflection Inspection in Periodic Maintenance chapter.

Drive Belt Deflection Adjustment

- Refer to Drive Belt Deflection Adjustment in Periodic Maintenance chapter.

Drive Belt Inspection

- Refer to Drive Belt Inspection in Periodic Maintenance chapter.

Drive Pulley

Drive Pulley Removal

- Remove:
 - Torque Converter Cover (see Torque Converter Cover Removal)
- Remove the three bolts of the drive pulley cover.
- Install and tighten the drive pulley holder [A] and the three bolts [B] as shown.

Special Tool - Drive Pulley Holder: 57001-1520

- Loosen the drive pulley bolt [C].

NOTE

- *The drive pulley bolt has left-hand threads. Turn the wrench clockwise for loosening.*

- Using the drive pulley holder [A] and drive pulley puller bolt [B], remove the drive pulley [C] from the crankshaft.

Special Tools - Drive Pulley Puller Bolt: 57001-1429

Drive Pulley Holder: 57001-1520

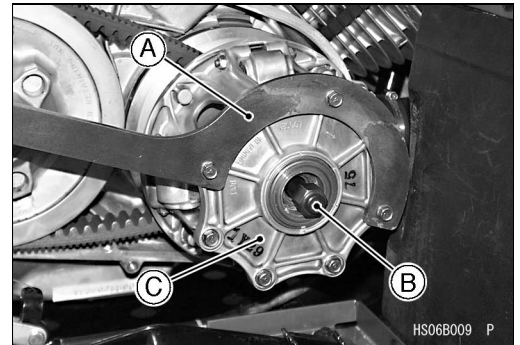
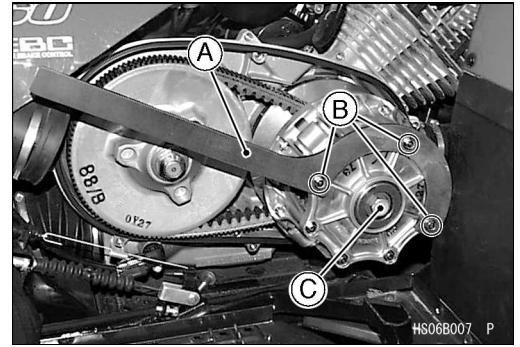

Drive Pulley Disassembly

- Hold the drive & driven pulley holder [A] and guide (57001-1412) [B] in a vise so that the upper surface on the holder is 7 mm (0.28 in.) [C] above the vise.

Special Tools - Drive Pulley Holder: 57001-1473

Drive & Driven Pulley Holder: 57001-1412

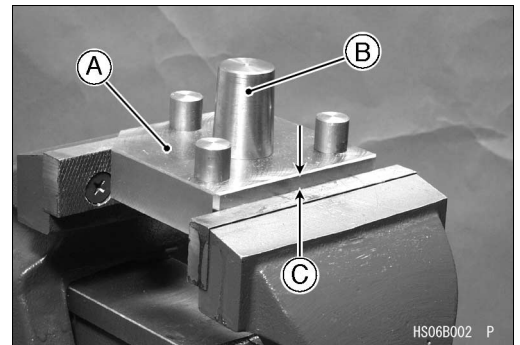

- Set the pulley onto the pulley holder.
- Remove:
 - Drive Pulley Cover Bolts [A]
 - Drive Pulley Cover [B]

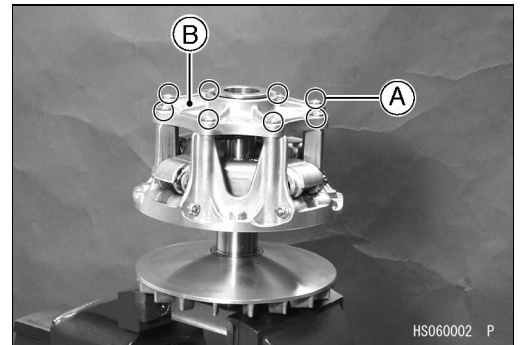

- Remove:
 - Spring [A]
 - Spacer

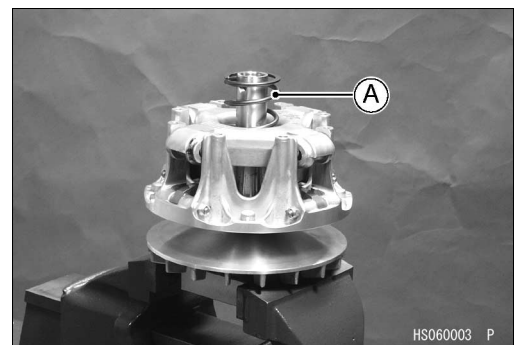

5-12 CONVERTER SYSTEM

Drive Pulley

- Put the drive pulley wrench [A] on the spider [B] and tighten the bolt [C].

Special Tool - Drive Pulley Wrench: 57001-1474

- Turn the wrench clockwise and remove the spider with the movable sheave.

NOTE

- *The spider has left-hand threads. Turn the wrench clockwise for loosening.*

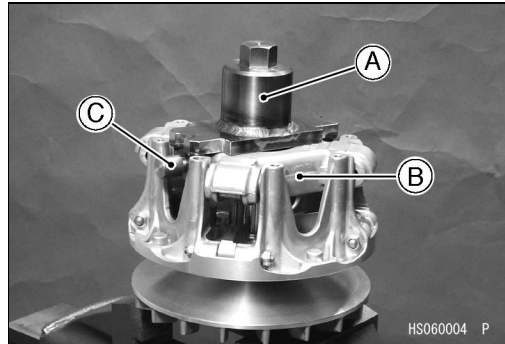

- Remove:
 - Spider [A]
 - Shoes [B]
 - Nuts [C]
 - Ramp Weight Pin [D]
 - Ramp Weight [E]
 - Movable Sheave [F]
 - Fixed Sheave [G]

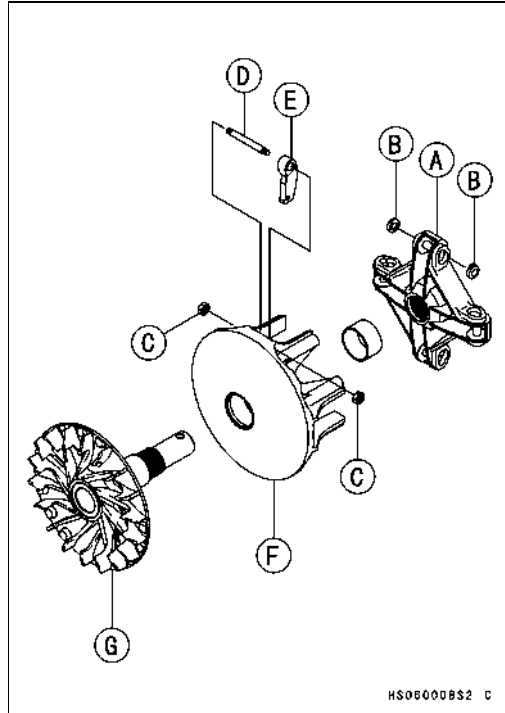

Drive Pulley Inspection

- ★ If the sheave surfaces [A] appear damaged, replace the sheaves.

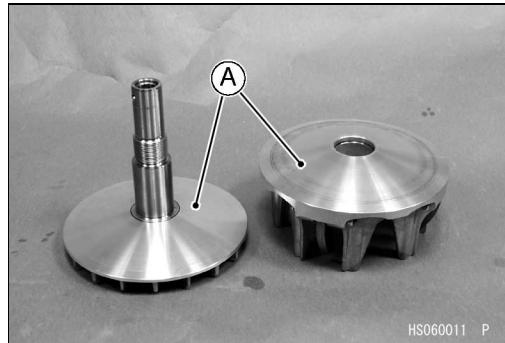

- ★ If the cover bushing is damaged or worn, replace the drive pulley cover.

Cover Bushing Inside Diameter [A]

Standard: 27.985 ~ 28.085 mm (1.1018 ~ 1.1057 in.)

Service Limit: 28.12 mm (1.107 in.)

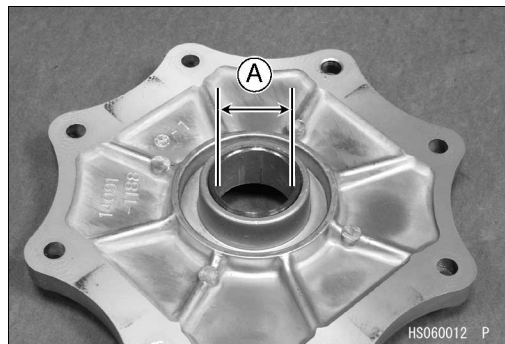

Drive Pulley

★ If the sheave bushing is damaged or worn, replace it.

Sheave Bushing Inside Diameter [A]

Standard: 37.985 ~ 38.085 mm (1.4955 ~ 1.4994 in.)
Service Limit: 38.12 mm (1.501 in.)

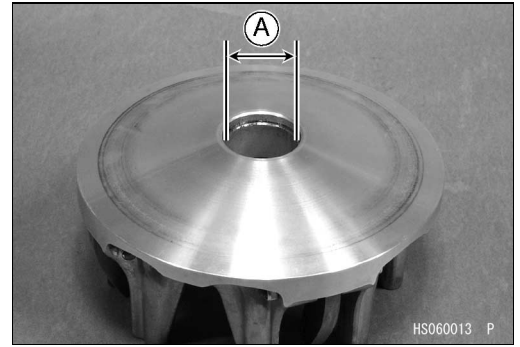

★ If the spider shoes [A] are damaged, replace them.

● Check the spider shoe side clearance (see Spider Shoe Side Clearance Inspection).

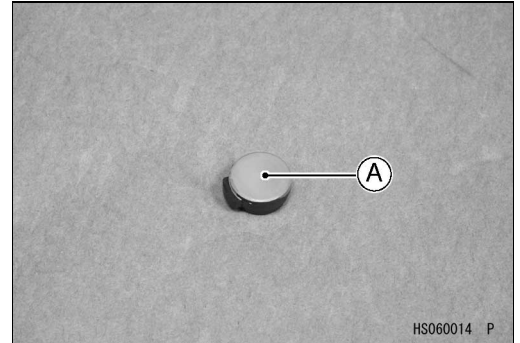

★ If the ramp weights [A] are damaged or worn, replace them.

★ If the pins [B] are damaged or worn, replace them.

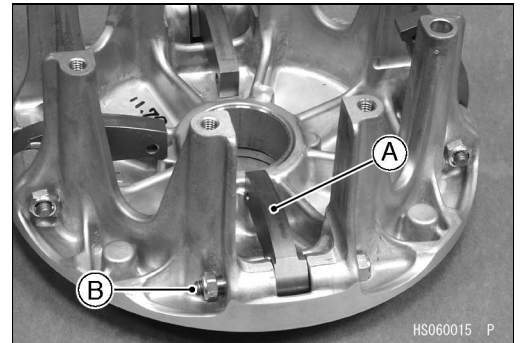

★ If the rollers [A] are damaged or worn, replace the spider [B].

★ If the washers [C] are damaged or worn, replace the spider.

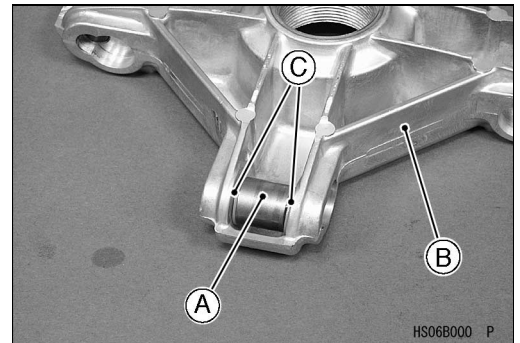

★ If the spring is worn or damaged, replace the spring.

Spring Free Length [A]

Standard: 60 mm (2.36 in.)

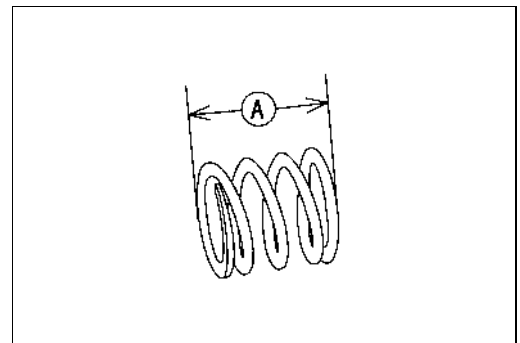

5-14 CONVERTER SYSTEM

Drive Pulley

Spider Shoe Side Clearance Adjustment

- Remove:
 - Drive Pulley (see Torque Converter Removal)
 - Drive Pulley Cover and Spring (see Drive Pulley Disassembly)
- Temporarily install:
 - Dowel Pins (2)
 - Drive Pulley Cover
 - Two Bolts (at dowel pins)
- Turn the movable sheave clockwise.
- Measure the resulting clearance [A] between the shoe [B] and the post [C] on the movable sheave at all four arms.

Shoe Side Clearance

Standard: 0.15 ~ 0.30 mm (0.0059 ~ 0.0118 in.)

- ★ If any of the measurements are greater than the maximum, replace all shoes with standard shoes (P/No. 49048-1080) (see Drive Pulley Disassembly).

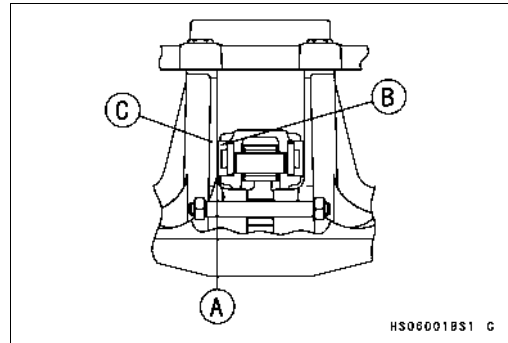

- Turn the movable sheave clockwise.
- Measure the resulting clearance [A] between the shoe [B] and the post [C] on the movable sheave at two positions as shown. [D] Arrow Mark
- ★ If the clearance is not within the specified range, adjust it according to following chart.

Clearance Measurement	Present Shoes	
	Part Number	Thickness
up to 0.15 mm (0.0059 in.)	49048-1078	7.2 mm (0.283 in.)
	49048-1079	7.3 mm (0.287 in.)
over 0.15 to 0.30 mm (over 0.0059 to 0.0118 in.) (standard clearance)	no change	
	49048-1080	7.4 mm (0.291 in.)
over 0.30 mm (0.0118 in.)	49048-1081	7.5 mm (0.295 in.)
	49048-1082	7.6 mm (0.299 in.)
	49048-1083	7.7 mm (0.303 in.)
	49048-1084	7.8 mm (0.307 in.)
	49048-1085	7.9 mm (0.311 in.)
	49048-1086	8.0 mm (0.315 in.)

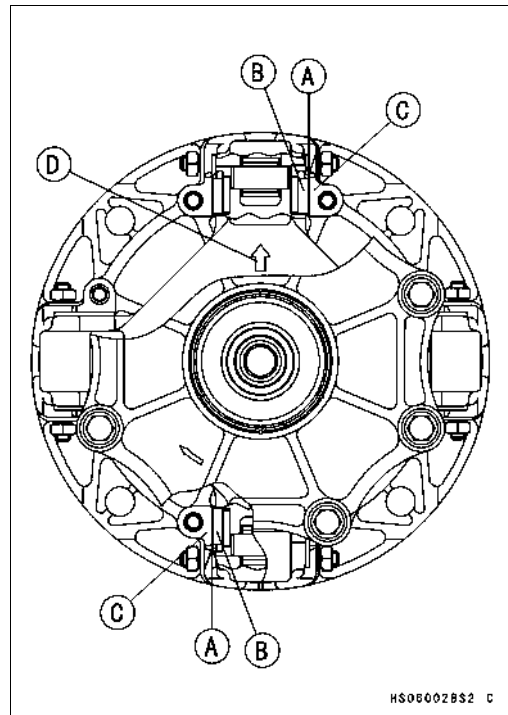

- Check that the movable sheave [A] moves smoothly, after the shoe side clearance adjustment.
- The movable sheave must move freely towards the fixed sheave [B].
- ★ If the movable sheave does not move smoothly, readjust the shoe side clearance.

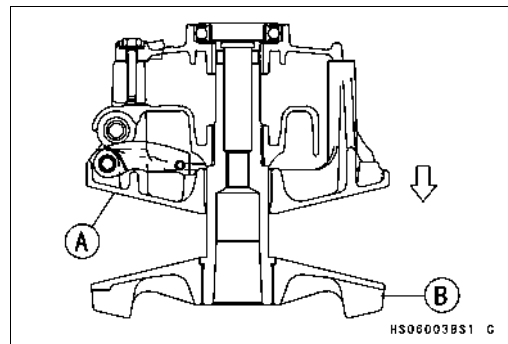

Drive Pulley

Drive Pulley Assembly

- Install the ramp weight [A] as shown.
- Tighten:
 - Torque - Ramp Weight Nuts [B]: 6.9 N·m (0.7 kgf·m, 61 in·lb)**
- Check that the ramp weights swing smoothly.

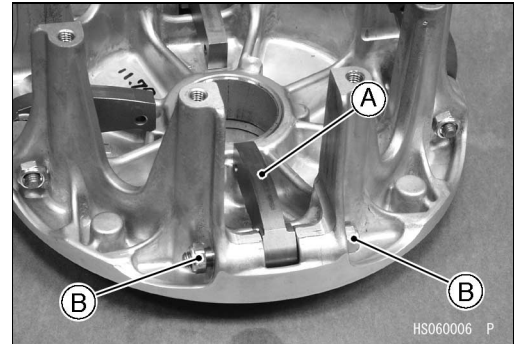

- Hold the fixed sheave [A] with the drive pulley holder [B] in a vise.
- Special Tool - Drive Pulley Holder: 57001-1473**

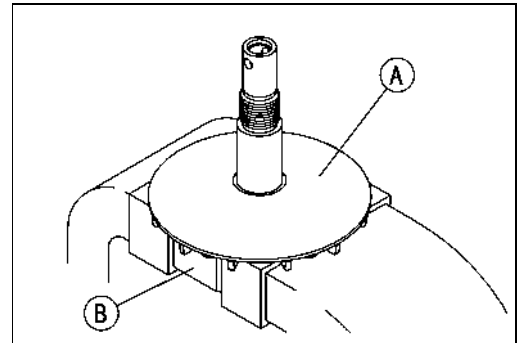

- Clean the threads of the fixed sheave and spider.
- Install:
 - Movable Sheave
 - Spider [A] and Wear Guides [B]
- Align the arrow [C] on the spider with the arrow [D] on the movable sheave.
- Insert the guides so that the rubber side (small diameter) faces inward.

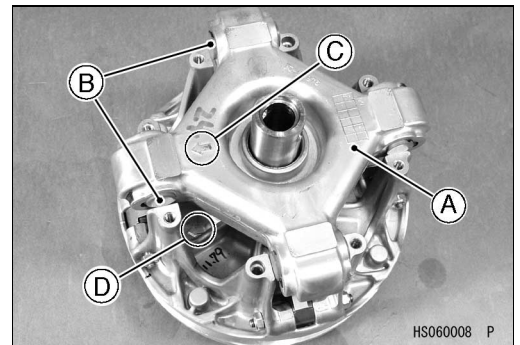

- Put the drive pulley wrench [A] on the spider [B] and tighten the bolt [C].

Special Tool - Drive Pulley Wrench: 57001-1474

- Turn the wrench counterclockwise for tightening.

Torque - Spider: 275 N·m (28 kgf·m, 203 ft·lb)

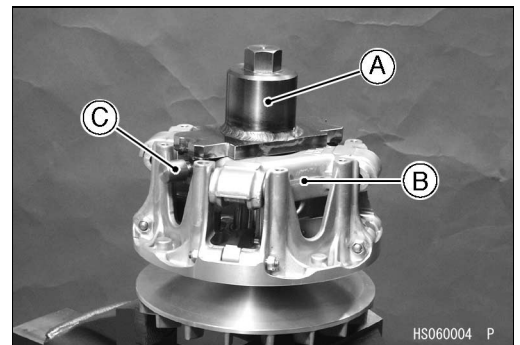

- Install the spacer.
- Put the spring [A] in the groove of the spider.
- Align the arrows [B] on the drive pulley cover and spider.

- Install:
 - Dowel Pins [C]
 - Drive Pulley Cover

- Tighten:

Torque - Drive Pulley Cover Bolts: 13 N·m (1.3 kgf·m, 113 in·lb)

- Clean the surface of the sheaves with an oil-less cleaning fluid.

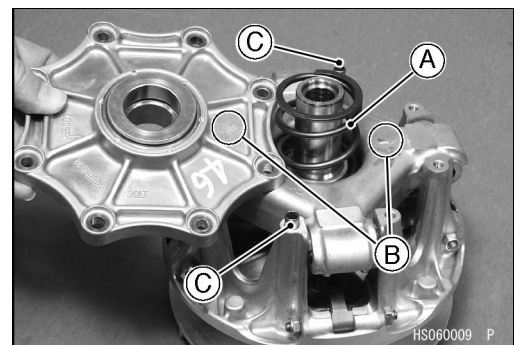

5-16 CONVERTER SYSTEM

Drive Pulley

Drive Pulley Installation

- Clean the following portions with an oil-less cleaning fluid such as trichloroethylene or acetone.
 - Fixed Sheave Tapered Portion [A]
 - Crankshaft Tapered Portion [B]

⚠ WARNING

These cleaning fluids are usually highly flammable and harmful if breathed for prolonged periods. Be sure to heed the fluid manufacturer's warnings.

- Install the drive pulley and washers (3) [A] on the drive pulley bolt as shown.

- Hold the drive pulley with the drive pulley holder [A].

Special Tool - Drive Pulley Holder: 57001-1520

- Tighten:

Torque - Drive Pulley Bolt [B] (New, left-hand threads): 93 N·m (9.5 kgf·m, 69 ft·lb)

- Adjust the installation length [A] of the drive pulley between the surface of the crankcase [B] and the collar [C] on the drive pulley as followings.

Drive Pulley Installation Length [A]

Standard: 149.85 ~ 150.95 mm (5.900 ~ 5.943 in.)

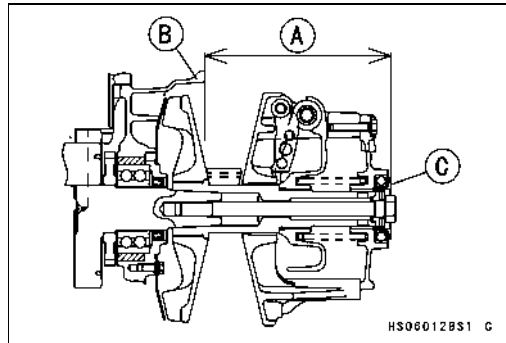
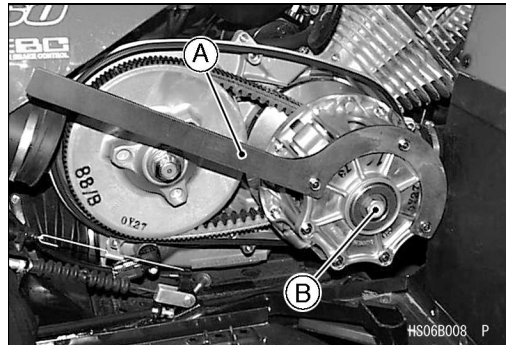
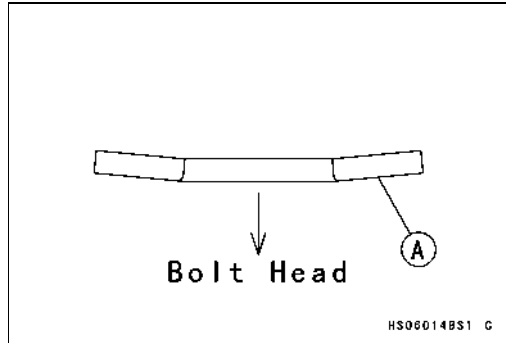
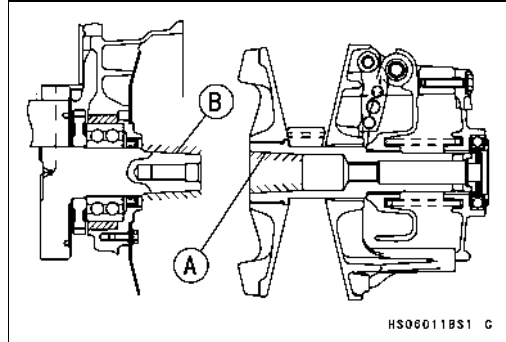

Drive Pulley

- Install the drive pulley measurement tool (legs [A] and plate [B]) on the crankcase [C].

Special Tool - Drive Pulley Measurement Tool: 57001-1498

- Measure the length [D] between the plate and collar [E] with Vernier calipers [F] or a depth gauge.

Measurement Length [D]

Standard: 14.55 ~ 15.65 mm (0.573 ~ 0.616 in.)

- ★ If the measurement is 14.55 mm (0.573 in.) or less, use the drive pulley cover (14041-1148) of red paint.
- ★ If the measurement is more than 15.65 mm (0.616 in.), use the drive pulley cover (14041-1149) of blue paint.
- ★ If the length is not within the specified length after the drive pulley cover is replaced, replace the drive pulley assembly.

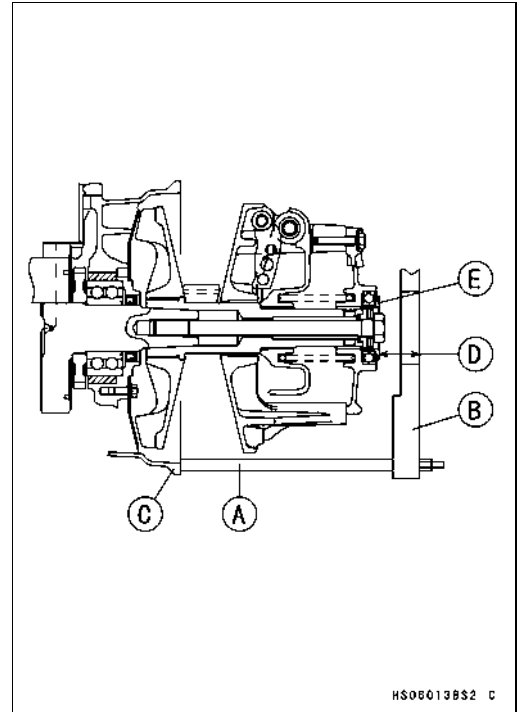
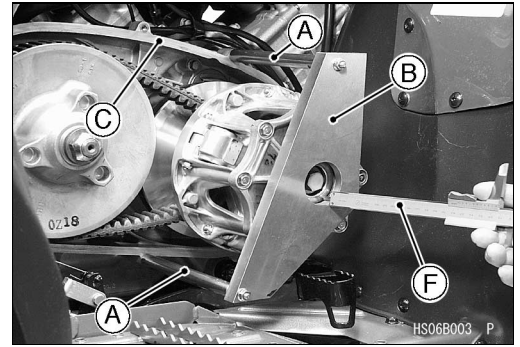

Drive Pulley Covers

Part Number	Paint Color [A]	Length [B]
14041-1148	Red	24.0 mm (0.945 in.)
14041-1149	Blue	25.4 mm (1.000 in.)
14041-1150	None	24.7 mm (0.972 in.)

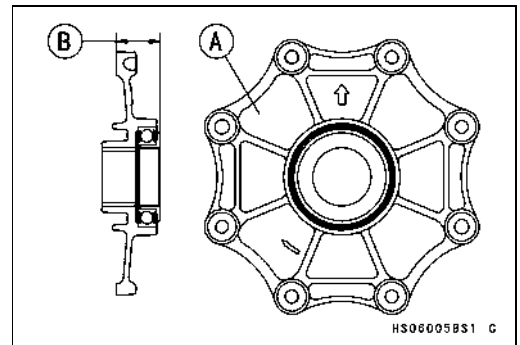

5-18 CONVERTER SYSTEM

Driven Pulley

Driven Pulley Removal

- Remove:
 - Torque Converter Cover (see Torque Converter Cover)
 - Drive Pulley (see Drive Pulley Removal)
 - Drive Belt (see Drive Belt Removal)
- Using a flywheel & pulley holder [A] and adapter [B], remove the driven pulley nut [C] and washers. (Nut has R/H threads.)

Special Tools - Flywheel & Pulley Holder: 57001-1343
Pulley Holder Attachment: 57001-1472

- Remove:
 - Driven Pulley

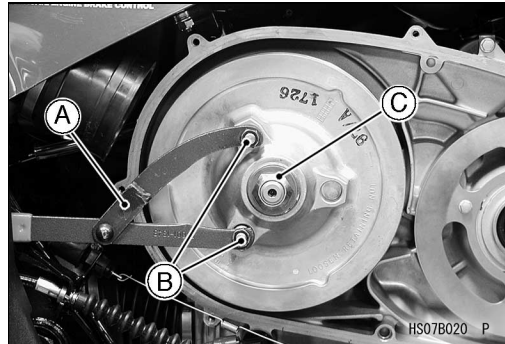

Driven Pulley Disassembly

- Hold the drive & driven pulley holder [A] in a vise.
 - Special Tool - Drive Pulley Holder: 57001-1473**
- Screw the guide bar [B] into the holder.
 - Special Tool - Spring Holder Set: 57001-1483**
- Put the driven pulley [C] on the guide bar.
- Tighten nut [D], and compress the spring with the spring holder [E].
 - Special Tool - Spring Holder Set: 57001-1483**

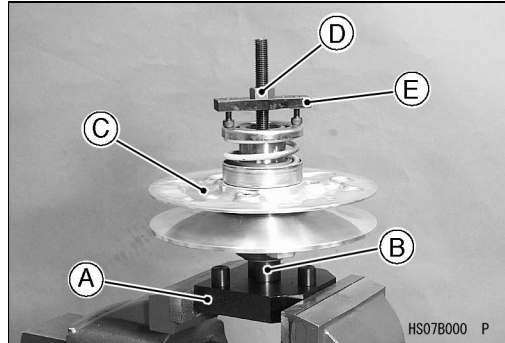

- Remove circlip [A] with circlip pliers [B].
 - Special Tool - Circlip Pliers: 57001-154**
- Remove nut and spring holder [C].

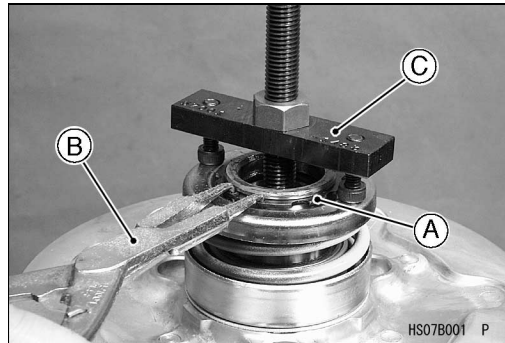

- Remove:
 - Spring Seats [A]
 - Spring [B]
 - Spring Spacer (if used, for high altitude setting)
 - Thrust Plate [C]

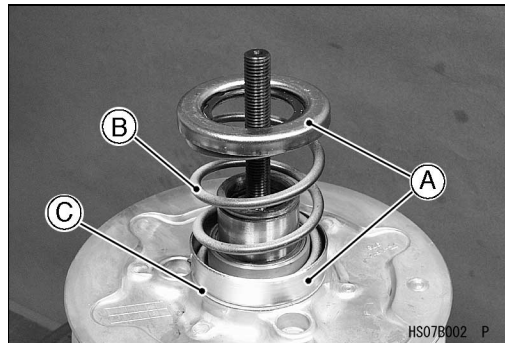

- Make match-marks [A] and [B] on the sheaves so that it can be installed later in the same position.
 - Movable Shoe [C]
 - Fixed Sheave [D]

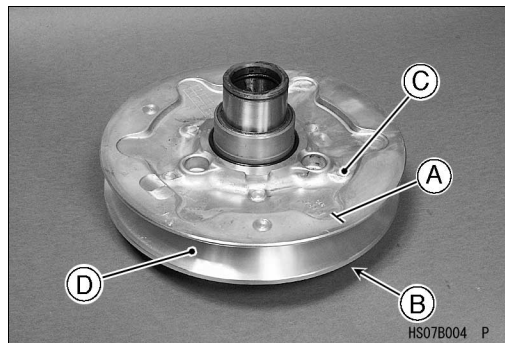

Driven Pulley

- Wipe off the molybdenum disulfide grease.
- Remove the four pins [A] with a thin standard tip screwdriver [B].
- Remove the movable sheave from the fixed sheave.

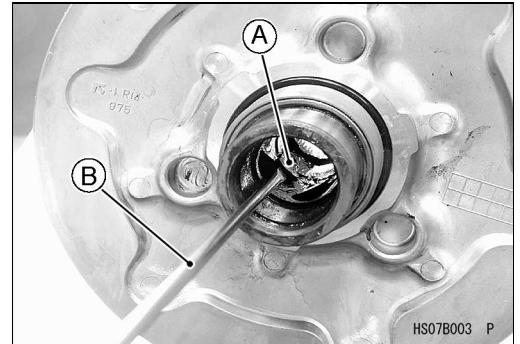

- Remove:
Spacer(s) [A] (for Drive Belt Deflection Adjustment)

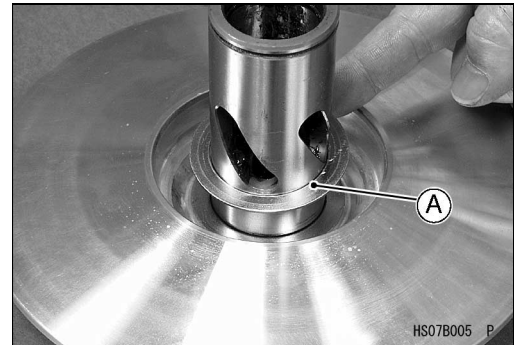

Driven Pulley Inspection

- ★ If the sheave surfaces [A] appear damaged, replace the sheaves.

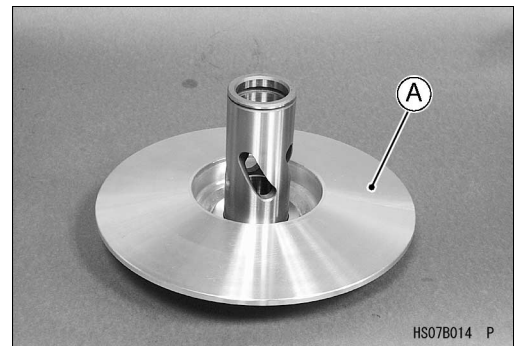
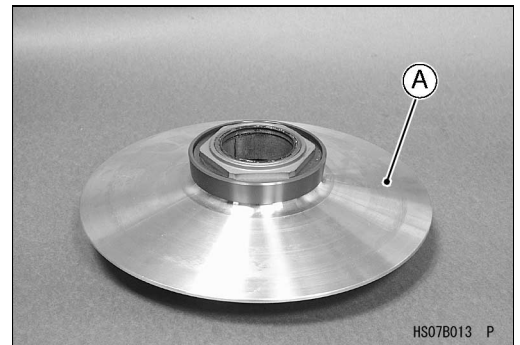

- Replace sheave with uneven wear on the belt contacting surfaces.
[A] Sheave Surface
[B] Straight Edge

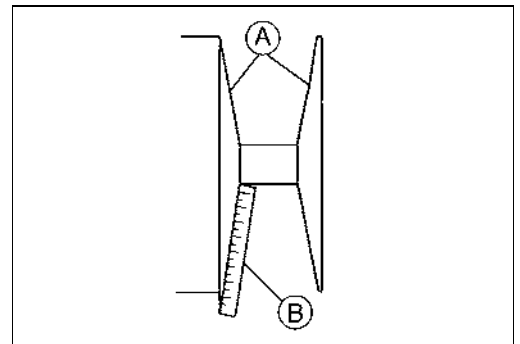

5-20 CONVERTER SYSTEM

Driven Pulley

- ★ If the guide bushings [A] are damaged or worn, replace the movable sheave.

Sheave Bushing Inside Diameter

Standard: 39.994 ~ 40.104 mm (1.5746 ~ 1.5789 in.)
Service Limit: 40.13 mm (1.580 in.)

- Inspect seals for damage.
- ★ If seals are damaged, replace the movable sheave.

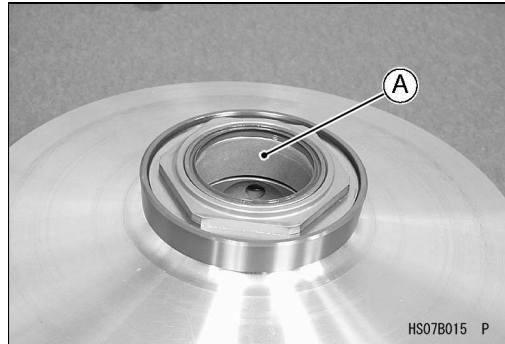

- ★ If the splines [A] are damaged or worn, replace the fixed sheave.

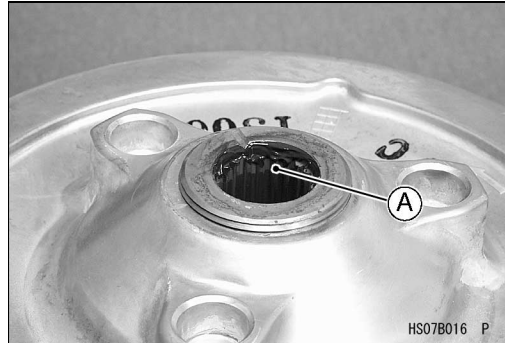

- ★ If the spring is damaged or worn, replace the spring.

Spring Free Length [A]

Standard: 75.1 mm (2.96 in.)

- ★ If the spring coils are distorted, replace the spring.

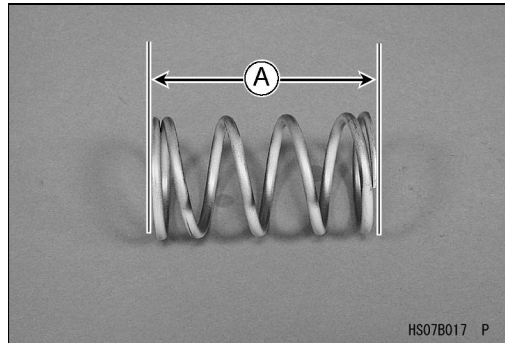

Driven Pulley Assembly

- Clean off any grease or dirt on the movable and fixed sheave, and dry them with a clean cloth.
- Install:
 - Spacers [A] (for Drive Belt Deflection Adjustment)

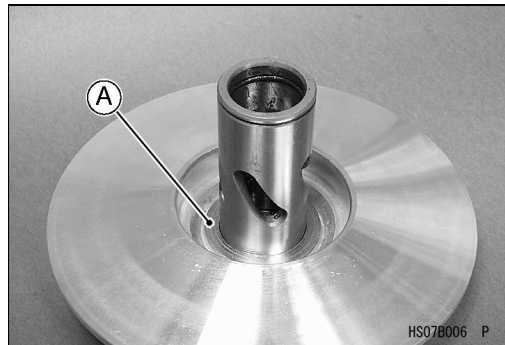

- Apply grease to the oil seal lips [A].
- Apply molybdenum disulfide grease to the inner surface of the bushings [B].
- When installing the new oil seal, press and insert it so that the seal surface is flush with the end of each housing in the movable sheave.

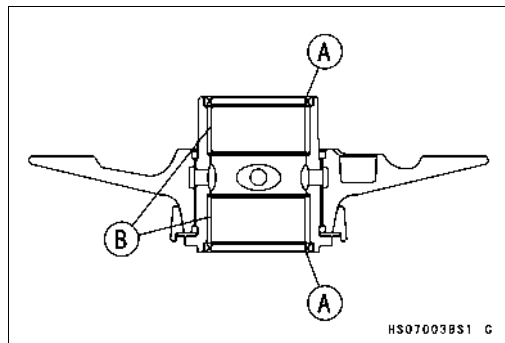

Driven Pulley

- Align the match-marks on the sheaves, made when disassembled, and the opening [A] and hole [B] will be matched easily.

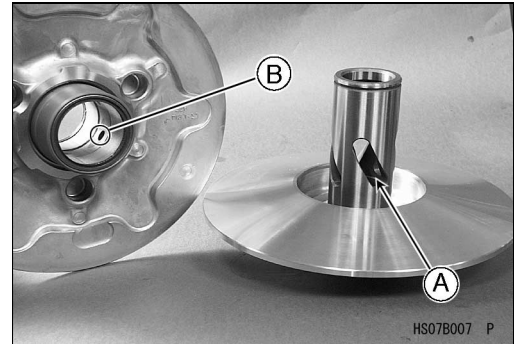

- Apply molybdenum disulfide grease to the seating surface [A] of the pins, and insert them into the holes in the movable sheave.

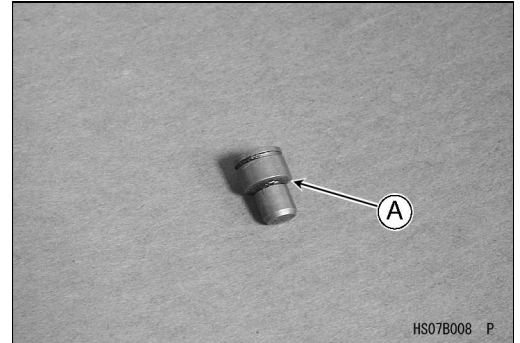

- Draw the movable sheave onto the fixed sheave, and apply molybdenum disulfide grease of 1 g (0.035 oz) to all openings [A].

NOTE

- Do not heap up the grease out of the openings.

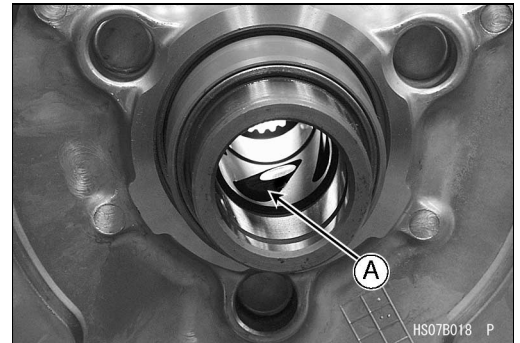

- Check that the O-rings [A] are in good condition.
- ★ If any of the O-rings are damaged, replace them.
- Apply grease to the O-rings.

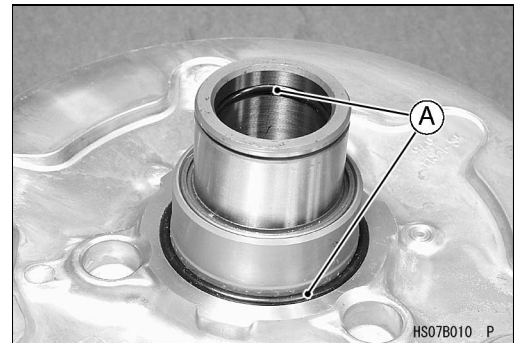

- Hold the drive & driven pulley holder in a vise.
 - Special Tool - Drive Pulley Holder: 57001- 1473
- Screw the guide bar into the holder.
 - Special Tool - Spring Holder Set: 57001-1483
- Put the driven pulley [A] onto the guide bar.
- Put the thrust plate [B] so that the alloy side (gray) faces the movable sheave.
- Install:
 - Spring Spacer (see High Altitude Setting Information)
 - Spring Seat [C] 18.5 mm (0.728 in.)
 - Spring [D]
 - Spring Seat [E] 9.3 mm (0.366 in.)
 - Circlip [F]

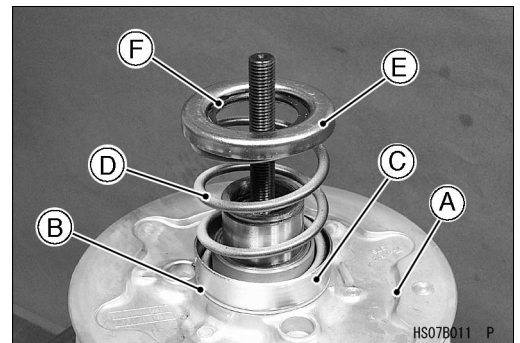

5-22 CONVERTER SYSTEM

Driven Pulley

- Tighten nut [A], and compress the spring with the spring holder [B].
Special Tool - Spring Holder Set: 57001-1483
- Install circlip [C] with circlip pliers [D].
Special Tool - Circlip Pliers: 57001-154
- Remove the driven pulley from the spring holder set.
- Clean the surface of the sheaves with an oil-less cleaning fluid.

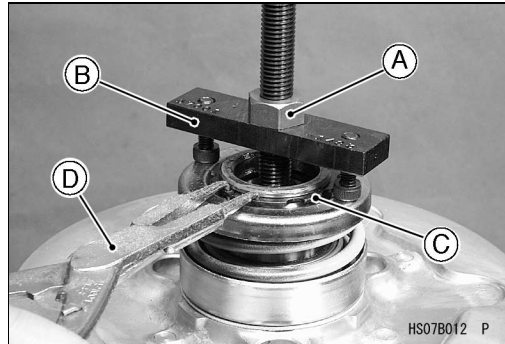

Driven Pulley Installation

- Clean the transmission driven shaft [A].
- Install:
Driven Pulley

NOTE

- When engaging the spline on the driven pulley with the spline [B] on the shaft, do not damage the pulley's spline. If any damage occurs, remove it with a file.
- Clean the driven shaft and driven pulley ends to open the air vent passage. Wipe off any extra grease.
 - Wipe off any protruding grease [A].

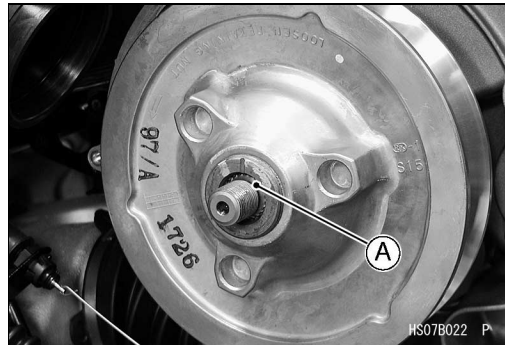
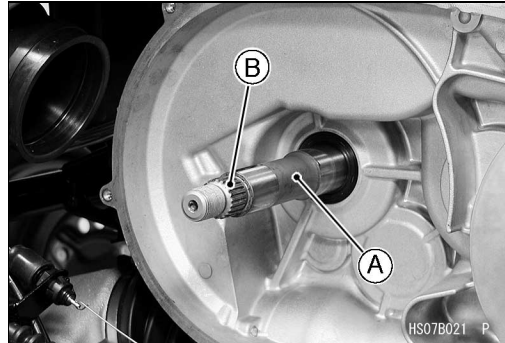

- Install the washers [A] on the shaft as shown.

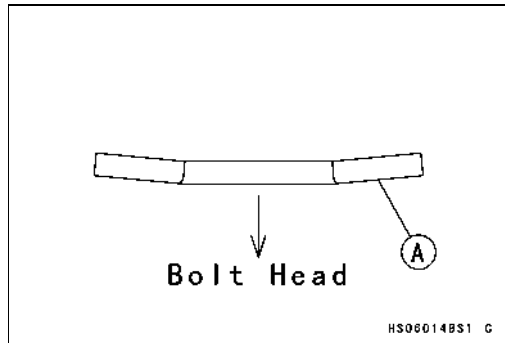

- Using a flywheel & pulley holder [A] and adapters [B], tighten the driven pulley nut [C].
Special Tools - Flywheel & Pulley Holder: 57001-1343
Pulley Holder Attachment: 57001-1472
- Torque - Driven Pulley Nut: 93 N·m (9.5 kgf·m, 69 ft·lb)**

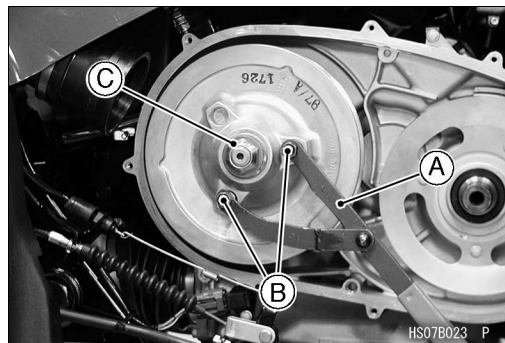

High Altitude Setting Information

Specifications

Altitude m (ft)	Drive Pulley		Driven Pulley	Carburetor
	Ramp Weight	Spring	Spring Spacer	Main Jet
0 ~ 500 (0 ~ 1,700)	P/No. 39152-1096 (STD, EC)	P/No. 92145-1465 (STD, Pink)	—	P/No. 92063-1332 (STD) #155 or P/No. 92063-1344 #158
500 ~ 1,400 (1,700 ~ 4,700)	P/No. 39152-1096 (STD, EC)	P/No. 92145-1465 (STD, Pink)	—	P/No. 92063-1332 (STD) #155
1,400 ~ 2,300 (4,700 ~ 7,700)	P/No. 39152-1098 (EC-H1)	P/No. 92145-1187 (Gray)	P/No. 92026-1623	P/No. 92063-1017 #145
2,300 ~ 3,300 (7,700 ~ 10,700)	P/No. 39152-1100 (EC-H2)	P/No. 92145-1187 (Gray)	P/No. 92026-1623 x 2 pc.	P/No. 92063-1014 #135
3,300 ~ 4,500 (10,700 ~ 14,800)	P/No. 39152-1100 (EC-H2)	P/No. 92145-1187 (Gray)	P/No. 92026-1623 x 2 pc.	P/No. 92063-1069 #125

Refer to the Drive Pulley and Drive Pulley sections in this chapter and Carburetor section in Fuel System chapter for the parts replacement.

Recoil Starter

Table of Contents

Exploded View.....	6-2
Recoil Starter.....	6-4
Recoil Starter Removal.....	6-4
Recoil Starter Installation.....	6-4
Recoil Starter Inspection.....	6-4

6-2 RECOIL STARTER

Exploded View

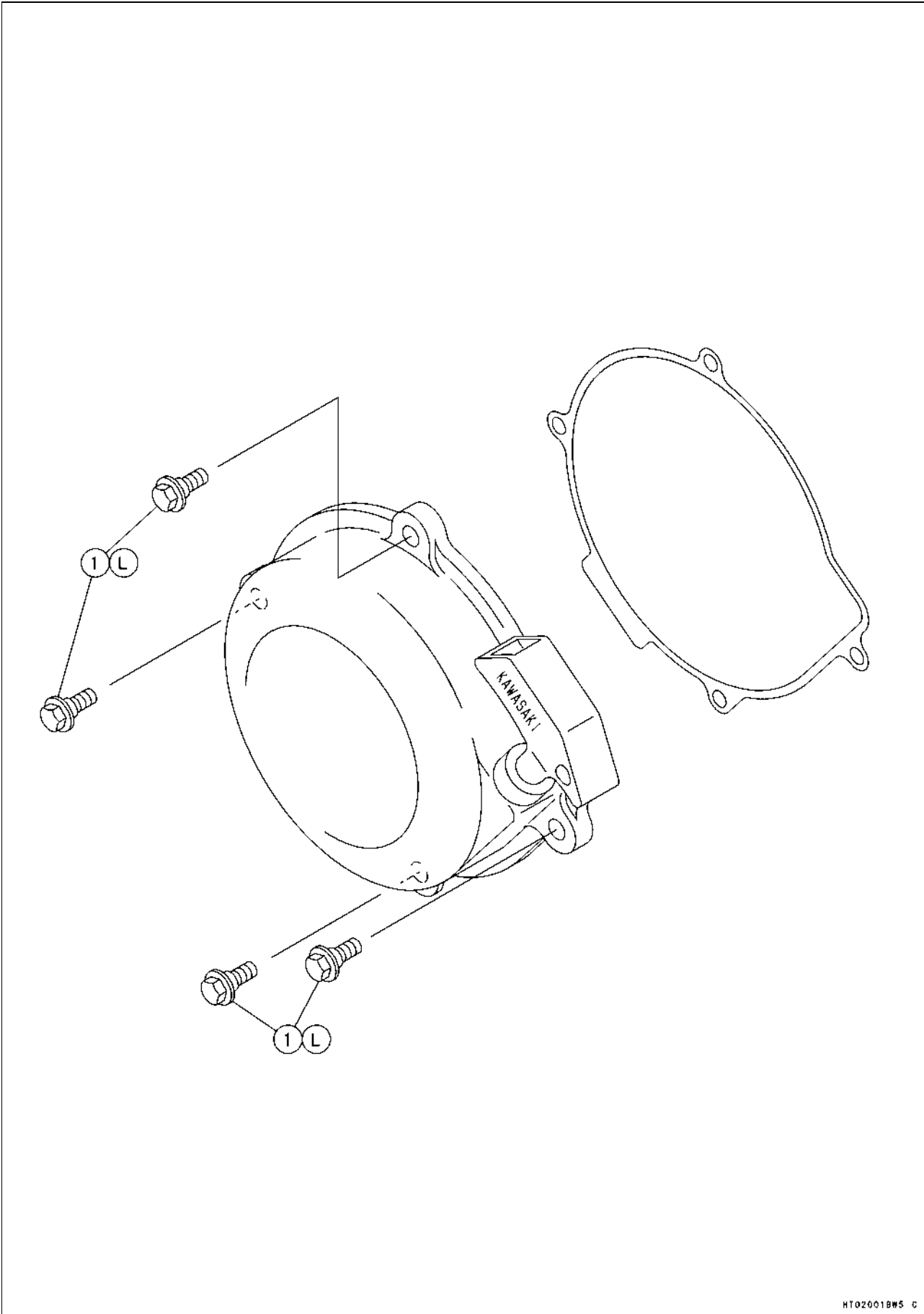

RECOIL STARTER 6-3

Exploded View

No.	Fastener	Torque			Remarks
		N·m	kgf·m	ft·lb	
1	Recoil Starter Mounting Bolts	5.9	0.6	52 in·lb	L

L: Apply a non-permanent locking agent.

6-4 RECOIL STARTER

Recoil Starter

Recoil Starter Removal

- Remove:
 - Recoil Starter Mounting Bolts [A]
 - Recoil Starter [B]

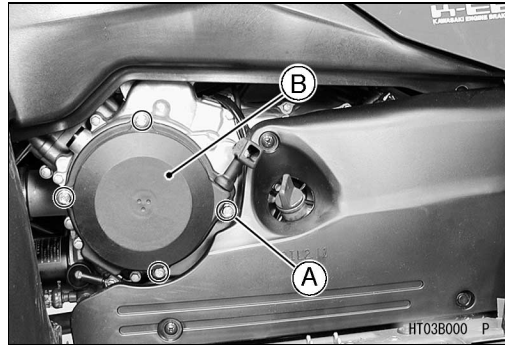

Recoil Starter Installation

- Apply a non-permanent locking agent:
 - Recoil Starter Mounting Bolts
- Tighten:
 - Torque - Recoil Starter Mounting Bolts: 5.9 N·m (0.6 kgf·m, 52 in·lb)**

Recoil Starter Inspection

- Check the starter rope for excessive wear or fraying.

Engine Lubrication System

Table of Contents

Exploded View.....	7-2
Specifications.....	7-4
Engine Oil Flow Chart.....	7-5
Engine Oil and Oil Filter.....	7-6
Oil Level Inspection.....	7-6
Engine Oil Change.....	7-6
Oil Filter Change.....	7-6
Oil Screen Removal.....	7-6
Oil Screen Cleaning.....	7-7
Oil Pressure Measurement.....	7-8
Oil Pressure Measurement.....	7-8
Oil Pressure Relief Valve.....	7-9
Oil Pressure Relief Valve Removal.....	7-9
Oil Pressure Relief Valve Installation.....	7-9
Oil Pressure Relief Valve Inspection.....	7-9
Oil Pump.....	7-10
Oil Pump Removal.....	7-10
Oil Pump Installation.....	7-10
Oil Pipe/Oil Hose.....	7-11
Oil Pipe Removal.....	7-11
Oil Pipe Installation.....	7-11
Oil Hose Removal.....	7-12
Oil Hose Installation.....	7-12
Oil Cooler.....	7-13
Oil Cooler Removal.....	7-13
Oil Cooler Installation.....	7-13
Oil Cooler Disassembly.....	7-13
Oil Cooler Fan Switch, Oil Temperature Warning Light Switch Removal.....	7-14
Oil Cooler Fan Switch, Oil Temperature Warning Light Switch Installation.....	7-14
Oil Cooler Fan Switch, Oil Temperature Warning Light Switch Inspection.....	7-14
Oil Cooler Inspection.....	7-14

7-2 ENGINE LUBRICATION SYSTEM

Exploded View

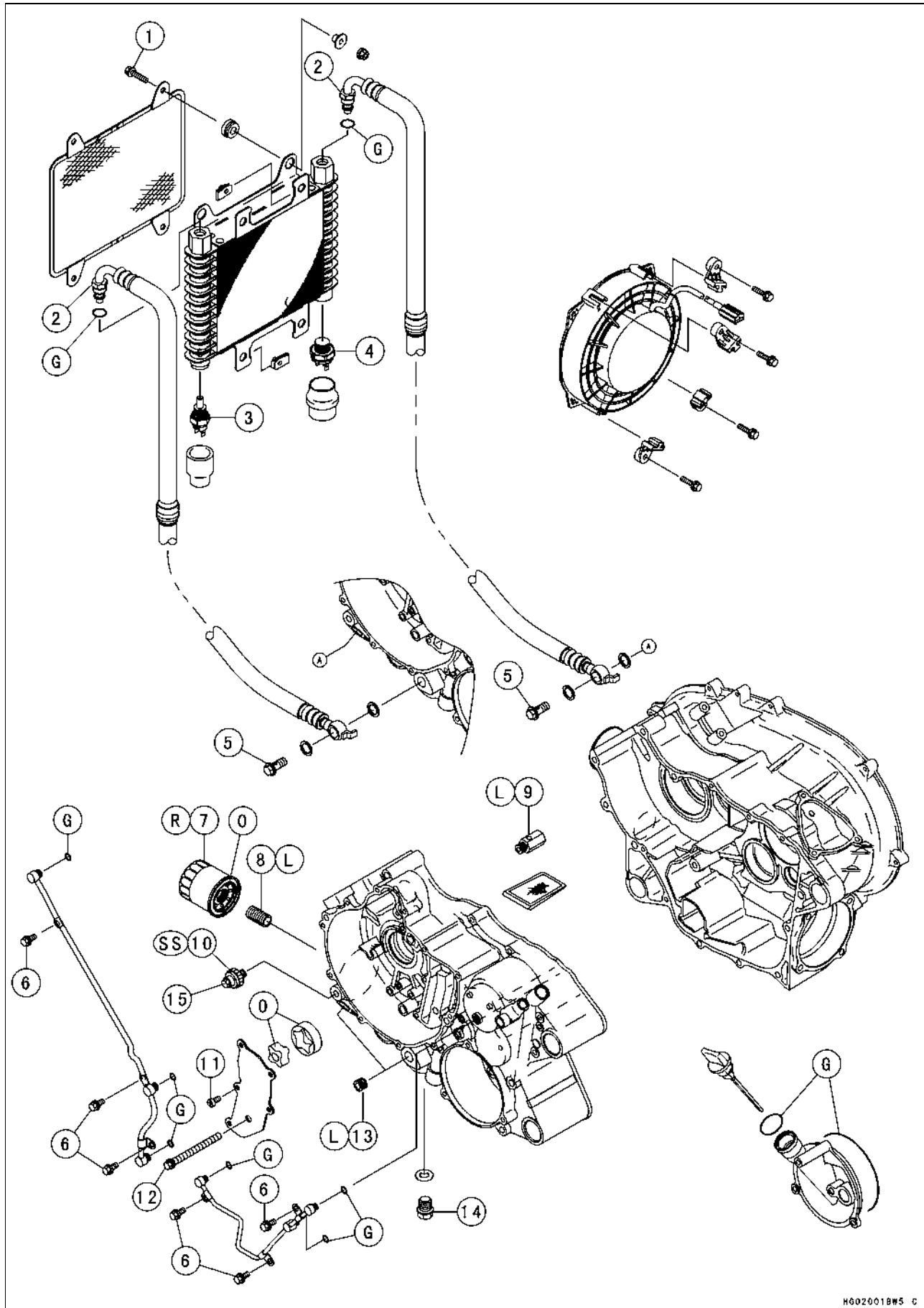

ENGINE LUBRICATION SYSTEM 7-3

Exploded View

No.	Fastener	Torque			Remarks
		N·m	kgf·m	ft·lb	
1	Oil Cooler Mounting Bolts	8.8	0.9	78 in·lb	
2	Oil Pipe Joint Nuts	29	3.0	22	
3	Oil Cooler Fan Switch	16	1.6	12	
4	Oil Temperature Warning Light Switch	16	1.6	12	
5	Oil Hose Banjo Bolts	29	3.0	22	
6	Oil Pipe Bolts	8.8	0.9	78 in·lb	
7	Oil Filter	18	1.8	13	R
8	Oil Filter Mounting Bolt	25	2.5	18	L
9	Oil Pressure Relief Valve	15	1.5	11	L
10	Oil Pressure Switch	15	1.5	11	SS
11	Oil Pump Cover Screws	5.4	0.55	48 in·lb	
12	Oil Pump Cover Bolt	20	2.0	14	
13	Oil Line Plugs	23	2.3	17	L
14	Engine Drain Plug	20	2.0	14	
15	Oil Pressure Switch Terminal Bolt	1.5	0.15	13 in·lb	

G: Apply grease for oil seal and O-ring.

L: Apply a non-permanent locking agent.

O: Apply engine oil.

SS: Apply silicone sealant (Kawasaki Bond: 56019-120).

R: Replacement Parts

7-4 ENGINE LUBRICATION SYSTEM

Specifications

Item	Standard
Engine Oil: Type Viscosity Capacity	API SF or SG API SH or SJ with JASO MA SAE 10W-40 1.50 L (1.59 US qt) (when filter is not removed) 1.74 L (1.84 US qt) (when filter is removed) 2.3 L (2.43 US qt) (when engine is completely dry)
Oil Pressure Measurement: Oil Pressure @ 4500 r/min (rpm), oil temp. 120°C (248°F)	177 kPa (1.8 kg/cm ² , 25.6 psi)

- Special Tools - Oil Filter Wrench: 57001-1249**
Oil Pressure Gauge, 10 kgf/cm²: 57001-164
Oil Pressure Gauge Adapter: 57001-1033
- Sealant - Kawasaki Bond (Silicone Sealant): 57001-120**

ENGINE LUBRICATION SYSTEM 7-5

Engine Oil Flow Chart

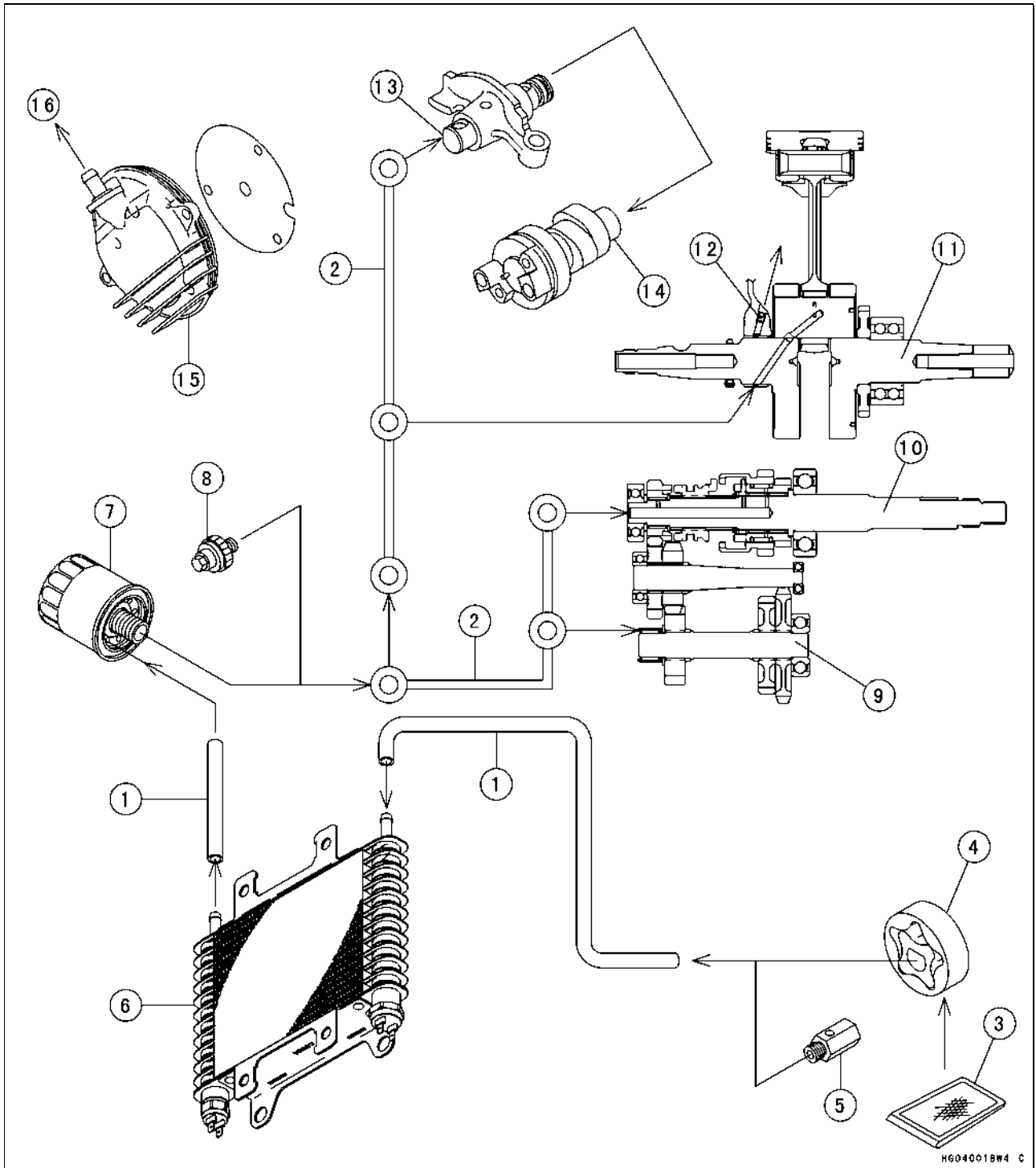

H604001BW4 C

- | | | |
|-----------------|------------------------|----------------------------------|
| 1. Oil Hose | 7. Oil Filter | 12. Oil Nozzle |
| 2. Oil Pipe | 8. Oil Pressure Switch | 13. Rocker Shaft |
| 3. Oil Screen | 9. Drive Shaft | 14. Camshaft |
| 4. Oil Pump | 10. Input Shaft | 15. Engine Breather |
| 5. Relief Valve | 11. Crankshaft | 16. Blow-by Gas (to Air Cleaner) |
| 6. Oil Cooler | | |

7-6 ENGINE LUBRICATION SYSTEM

Engine Oil and Oil Filter

⚠ WARNING

Vehicle operation with insufficient, deteriorated, or contaminated engine oil will cause accelerated wear and may result in engine or transmission seizure, accident, and injury.

Oil Level Inspection

- Park the vehicle so that it is level, both side-to-side and front-to-rear.
- If the oil has just been changed, start the engine, and run it for several minutes to fill the oil filter.

CAUTION

Allow the engine to idle for several minutes so that oil may reach all parts of the engine. Raising a "dry" engine may cause severe damage.

- Stop the engine and wait several minutes for all the oil to drain back to the sump.
- Unscrew the oil filler cap, wipe its dipstick [A] dry, and tighten it into the filler opening.
- Unscrew the oil filler cap and check the oil level. The oil level should be between the upper (H) level line [B] and lower (L) level line [C].
- ★ If the level is too high, suck the excess oil out the filler hole with a syringe or other suitable device.
- ★ If the level is too low, add oil through the filler hole. Use the same type and make of oil that is already in the engine.

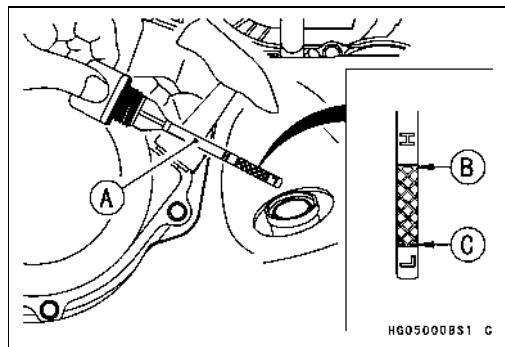

Engine Oil Change

- Refer to Engine Oil Change in Periodic Maintenance chapter.

Oil Filter Change

- Refer to Oil Filter Change in Periodic Maintenance chapter.

Oil Screen Removal

- Split the crankcase (see Crankshaft/Transmission chapter).
- Pull the oil screen [A] out of the crankcase.

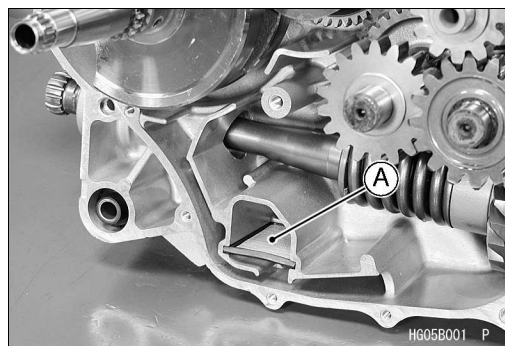

Engine Oil and Oil Filter

Oil Screen Cleaning

- Clean the oil screen [A] thoroughly whenever it is removed for any reason.
- Clean the oil screen with a high-flash point solvent and remove any particles stuck to it.

⚠ WARNING

Clean the screen in a well-ventilated area, and take care that there is no spark or flame anywhere near the working area. Because of the danger of highly flammable liquids, do not use gasoline or low flash-point solvents.

NOTE

- *While cleaning the screen, check for any metal particles that might indicate internal engine damage.*
- Check the screen carefully for any damage, holes, broken wires, or gasket pulling off.
- ★ If the screen is damaged, replace it.

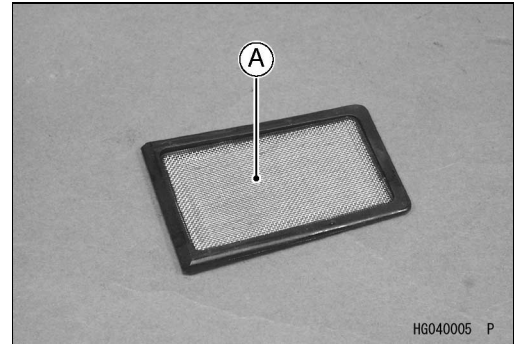

7-8 ENGINE LUBRICATION SYSTEM

Oil Pressure Measurement

Oil Pressure Measurement

NOTE

- Measure the oil pressure after the engine is warmed up.
- Remove the front left flap and oil pressure switch, and attach the oil pressure gauge [A] and adapter [B].

Special Tools - Oil Pressure Gauge, 10 kgf/cm²: 57001-164
Oil Pressure Gauge Adapter: 57001-1033

Oil Pressure

Standard: 177 kPa (1.8 kgf/cm², 25.6 psi) @ 4500 r/min (rpm), 120°C (248°F) of oil temp.

- ★ If the oil pressure is much lower than the standard, inspect the relief valve, oil pump, and/or crankshaft bearing insert wear.
- ★ If the oil pressure is much higher than the standard inspect the oil filter, oil screen, and other areas of the lubrication system for clogging.
- Stop the engine.
- Remove the oil pressure gauge and adapter.

⚠ WARNING

Take care against burns from hot engine oil that will drain through the oil passage when the gauge adapter is removed.

- Apply silicone sealant to the oil pressure switch, and tighten it.

Sealant - Kawasaki Bond (Silicone Sealant): 56019-120

Torque - Oil Pressure Switch: 15 N·m (1.5 kgf·m, 11 ft·lb)

Oil Pressure Switch Terminal Bolt: 1.5 N·m (0.15 kgf·m, 13 in·lb)

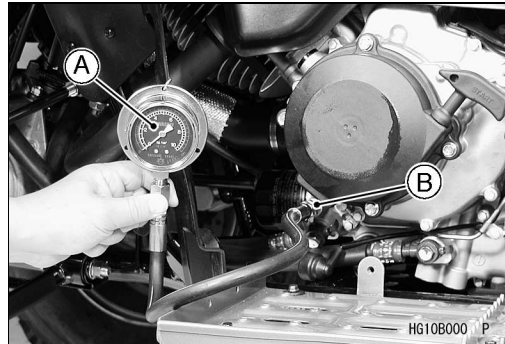

Oil Pressure Relief Valve

Oil Pressure Relief Valve Removal

- See Crankcase disassembly (see Crankshaft / Transmission chapter).
- Remove the oil pressure relief valve [A].

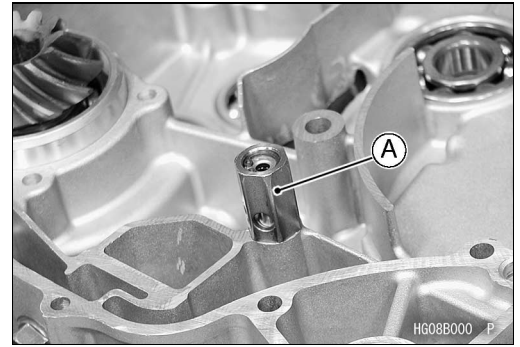

Oil Pressure Relief Valve Installation

- See crankcase assembly (see Crankshaft / Transmission chapter).
- Apply a non-permanent locking agent to the threads of oil pressure relief valve, and tighten it.

Torque - Oil Pressure Relief Valve: 15 N·m (1.5 kgf·m, 11 ft·lb)

Oil Pressure Relief Valve Inspection

- Remove the relief valve.
- Using a wooden stick, push the inner valve to make sure that the valve [A] moves smoothly and that it returns to its original position by the force of the spring [B].

NOTE

- *The relief valve cannot be disassembled and it must be inspected in the assembled state.*
- ★ If the valve movement is not smooth, wash the relief valve with high-flash point solvent, and use compressed air to remove any foreign particles from it.

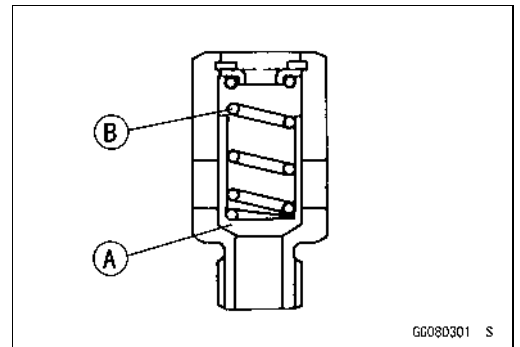

⚠ WARNING

Clean the oil pressure relief valve in a well-ventilated area, and take care that there is no spark or flame anywhere near the working area. Because of the danger of highly flammable liquids, do not use gasoline to low-flash point solvent.

- ★ If the valve does not move smoothly even after washing it, replace the relief valve. The oil pressure relief valve is precision made with no allowance for replacement of individual parts.

7-10 ENGINE LUBRICATION SYSTEM

Oil Pump

Oil Pump Removal

- Remove:
 - Alternator Rotor and Starter Clutch Gear (see Electrical System chapter)
 - Oil Pump Cover Screws [A]
 - Oil Pump Cover Bolt [B]
 - Oil Pump Cover [C]

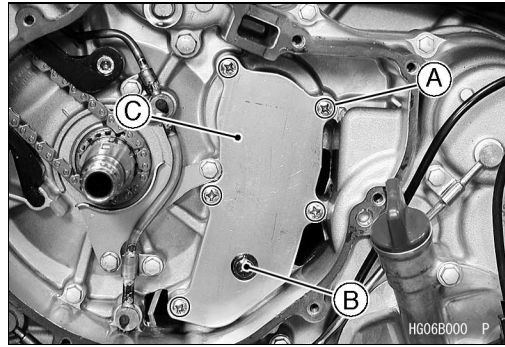

- Remove:
 - Inner Rotor [A]
 - Outer Rotor [B]

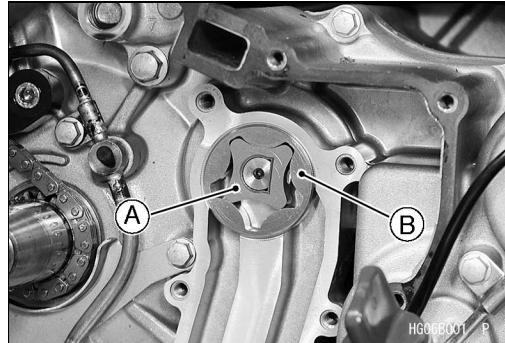

Oil Pump Installation

- Apply engine oil:
 - Inner and Outer Rotors
- Install:
 - Inner Rotor
 - Outer Rotor
 - Oil Pump Cover
- Tighten:
 - Torque - Oil Pump Cover Bolt: 20 N·m (2.0 kgf·m, 14 ft·lb)**
 - Oil Pump Cover Screws: 5.4 N·m (0.55 kgf·m, 48 in·lb)**

Oil Pipe/Oil Hose

Oil Pipe Removal

Engine Left Side Oil Pipe:

- Remove:
 - Engine Left Side Cover (see Frame chapter)
 - Oil Pipe Bolts [A]
 - Oil Pipe [B]

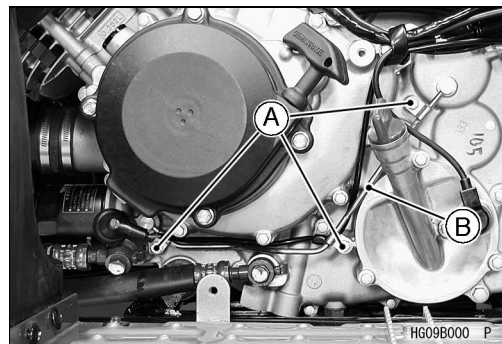

Engine Inside Oil Pipe:

- Remove:
 - Cylinder Head (see Engine Top End chapter)
 - Alternator Rotor and Starter Clutch Gear (see Electrical System chapter)
 - Rear Camshaft Chain Guide [A]

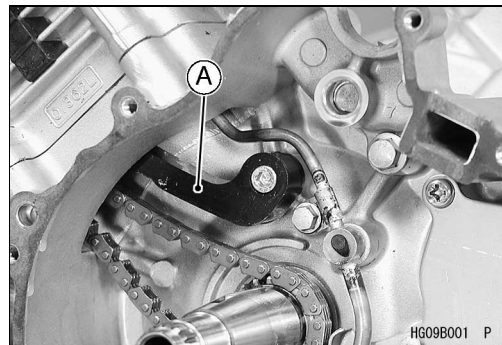

- Remove:
 - Oil Pipe Bolts [A]
 - Oil Pipe [B]

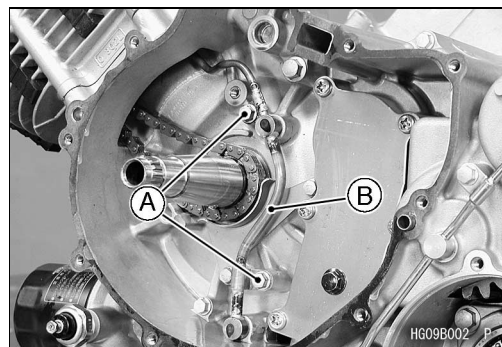

Oil Pipe Installation

- Replace the O-ring [A] with new ones if they are damaged.
- Apply grease to the O-rings before installation.
- Tighten:

Torque - Oil Pipe Bolts: 8.8 N·m (0.9 kgf·m, 78 in·lb)

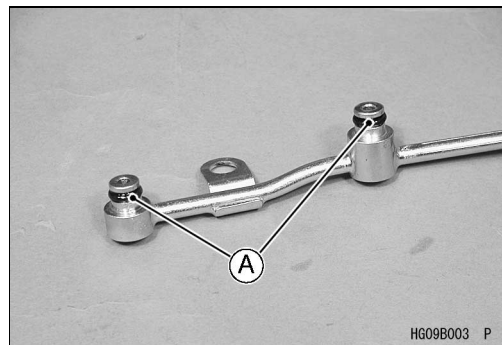

7-12 ENGINE LUBRICATION SYSTEM

Oil Pipe/Oil Hose

Oil Hose Removal

- Drain the engine oil (see Engine Oil Change).
- Remove:
 - Front Inner Covers (see Frame chapter)
 - Left Side Cover (see Frame chapter)
- Loosen the oil pipe joint nuts [A] and remove the oil pipes from the oil cooler [B].
- Remove:
 - Oil Hose Banjo Bolts [C]
 - Oil Hoses [D]

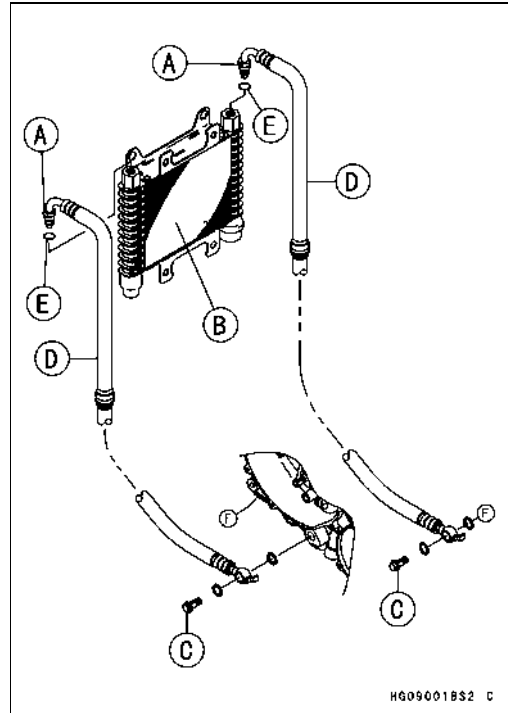

Oil Hose Installation

- Apply grease to the O-rings [E] on the oil pipe joint and insert them into the oil cooler.
- Rout the oil hoses according to Cable, Wire, and Hose Routing section in Appendix chapter.
- When installing the oil hose, avoid sharp bending, kinking, flattening or twisting, and route the oil hose with a minimum of bending so that the oil flow will not be obstructed.
- Tighten:
 - Torque - Oil Pipe Joint Nuts: 29 N·m (3.0 kgf·m, 22 ft·lb)**
- Install the rear ends of the oil hoses [A] on the crankcase as shown.
 - [B] 3°
 - [C] 6°
- Replace the washers on each side of the banjo bolt [D] with new ones.
- Tighten:
 - Torque - Oil Hose Banjo Bolts: 29 N·m (3.0 kgf·m, 22 ft·lb)**

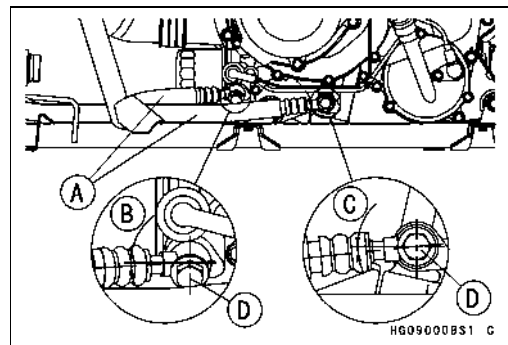

Oil Cooler

Oil Cooler Removal

⚠ WARNING

The oil cooler fan is connected directly to the battery. The oil cooler fan may start even if the ignition switch is off. NEVER TOUCH THE OIL COOLER FAN UNTIL THE OIL COOLER FAN CONNECTOR IS DISCONNECTED. TOUCHING THE FAN BEFORE THE CONNECTOR IS DISCONNECTED COULD CAUSE INJURY FROM THE FAN BLADES.

- Drain the engine oil (see Engine Oil Change).
- Remove:
 - Front Fender (see Frame chapter)
 - Oil Cooler Fan Switch Lead Connectors [A]
 - Oil Temperature Warning Light Switch Lead Connectors [B]
 - Oil Cooler Fan Motor Lead Connector
- Loosen the oil pipe joint nuts [C] and remove the oil pipes from the oil cooler [D].
- Remove:
 - Oil Cooler Mounting Bolts [E] and Nuts
 - Oil Screen and Oil Cooler

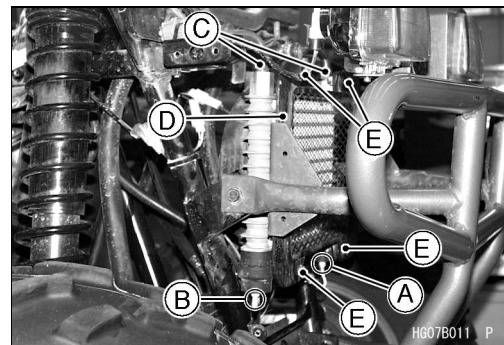

Oil Cooler Installation

- Connect:
 - Oil Cooler Fan Switch Lead Connectors
 - Oil Temperature Warning Light Switch Lead Connectors
 - Oil Cooler Fan Motor Lead Connector
- Install:
 - Oil Cooler [A]
 - Screen [B]
 - Fame [C]
 - Damper [D] (as shown)
 - Collar [E]
- Tighten:
 - Torque - Oil Cooler Mounting Bolts [F]: 8.8 N·m (0.9 kgf·m, 78 in·lb)**

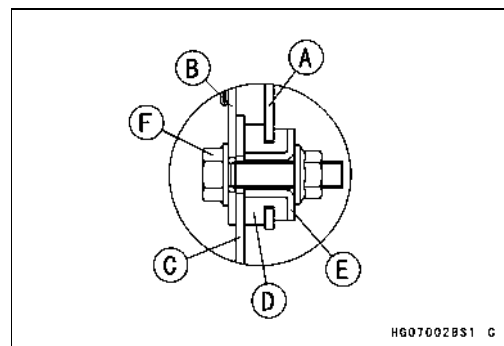

- Apply grease to the O-rings in the oil pipe joint and insert them into the oil cooler.
- Tighten:
 - Torque - Oil Pipe Joint Nuts: 29 N·m (3.0 kgf·m, 22 ft·lb)**

Oil Cooler Disassembly

- Remove:
 - Oil Cooler (see Oil Cooler Removal)
 - Fan Assembly Mounting Bolts [A]
 - Fan Assembly [B]

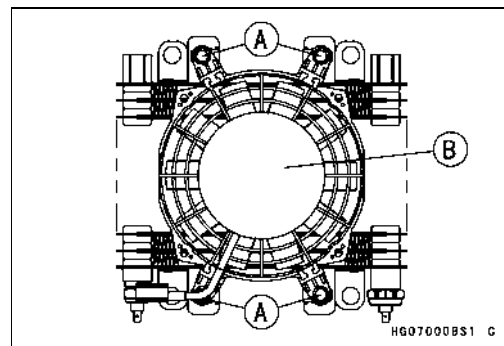

7-14 ENGINE LUBRICATION SYSTEM

Oil Cooler

Oil Cooler Fan Switch, Oil Temperature Warning Light Switch Removal

CAUTION

The oil cooler fan switch or the oil temperature warning light switch should never be allowed to fall on hard surface. Such a shock to their parts can damage them.

- Remove:
 - Oil Cooler (Oil Cooler Removal)
 - Oil Cooler Fan Switch [A]
 - Oil Temperature Warning Light Switch [B]

Oil Cooler Fan Switch, Oil Temperature Warning Light Switch Installation

- Apply grease to the O-rings of the oil cooler fan switch and oil temperature warning light switch.
- Tighten the oil cooler fan switch and oil temperature warning light switch.

Torque - Oil Cooler Fan Switch: 16 N·m (1.6 kgf·m, 12 ft·lb)
Oil Temperature Warning Light Switch: 16 N·m (1.6 kgf·m, 12 ft·lb)

Oil Cooler Fan Switch, Oil Temperature Warning Light Switch Inspection

- Refer to Electrical System chapter.

Oil Cooler Inspection

- Refer to Oil Cooler Cleaning and Inspection in Periodic Maintenance chapter.

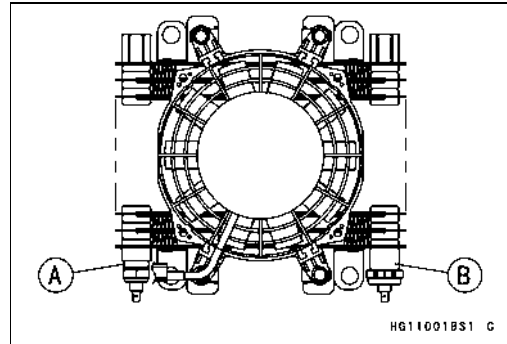

Engine Removal/Installation

Table of Contents

Exploded View.....8-2
Engine Removal/Installation.....8-4
 Engine Removal.....8-4
 Engine Installation.....8-5

8-2 ENGINE REMOVAL/INSTALLATION

Exploded View

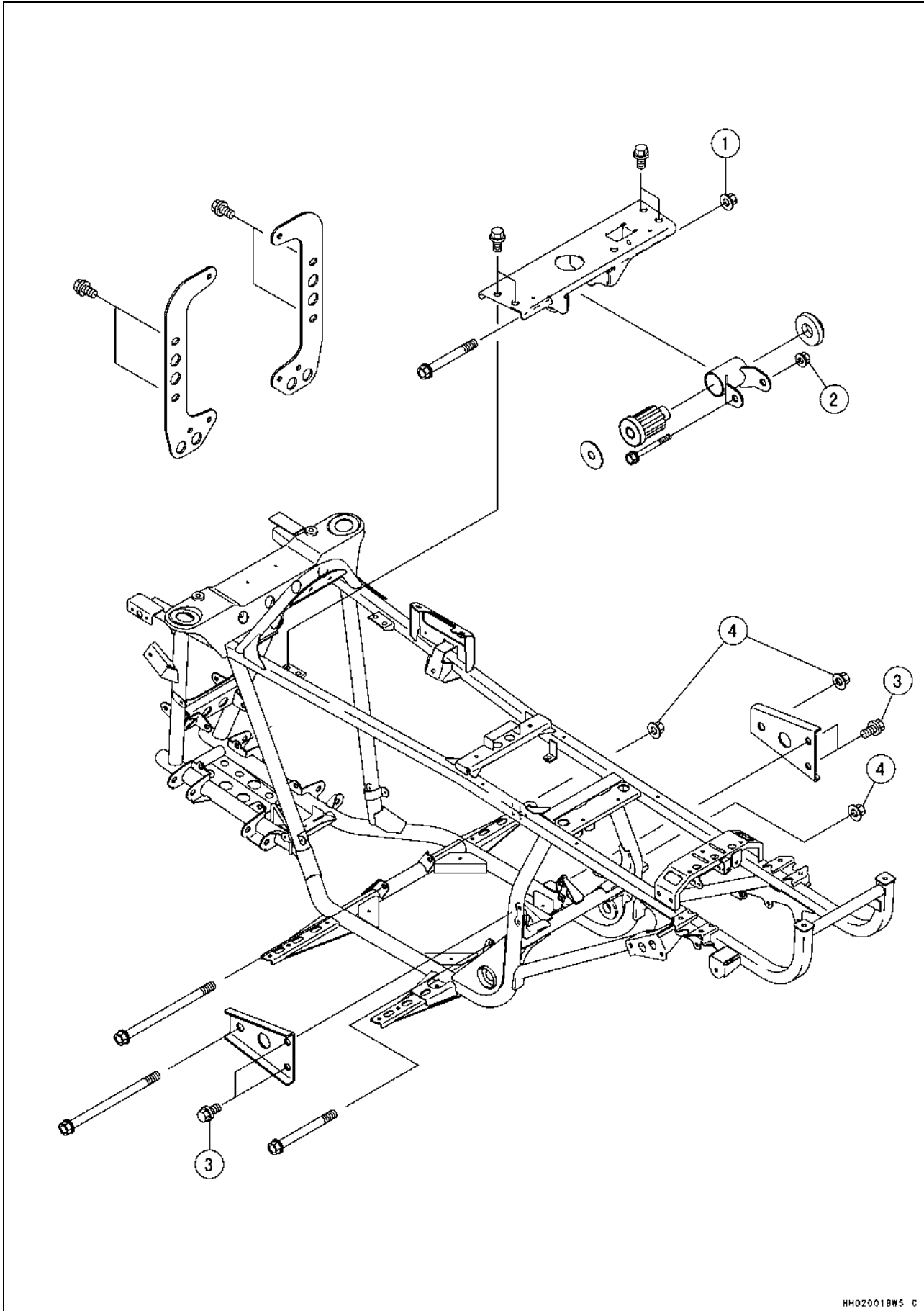

ENGINE REMOVAL/INSTALLATION 8-3

Exploded View

No.	Fastener	Torque			Remarks
		N·m	kgf·m	ft·lb	
1	Upper Engine Mounting Bracket Bolt and Nut	42	4.3	31	
2	Upper Engine Mounting Bolt and Nut	25	2.5	18	
3	Lower Engine Mounting Bracket Bolts	25	2.5	18	
4	Lower Engine Mounting Bolts and Nuts	42	4.3	31	

8-4 ENGINE REMOVAL/INSTALLATION

Engine Removal/Installation

Engine Removal

● Remove:

- Engine Oil (drain)
- Front Fender (see Frame chapter)
- Muffler and Exhaust Pipe (see Engine Top End chapter)
- Carburetor (see Fuel System chapter)
- Left Footboard (see Frame chapter)
- Torque Converter Air Intake Duct
- Tie-rod (Shift Lever)
- Engine Brake Actuator Lead Connector [A]
- Drive Belt Failure Detecting Switch Lead Connector [B]
- Spark Plug Cap [C]
- Front Propeller Shaft [D]
- Speed Sensor Connector [E]
- Torque Converter Air Duct [F]

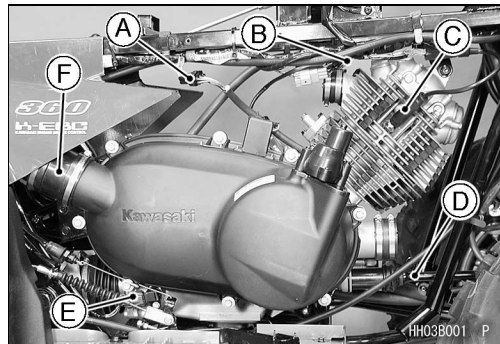

● Remove:

- Alternator Lead Connector
- Pickup Coil Lead Connector
- Forward/Reverse Detecting Sensor Lead Connector
- Reverse Position Switch Lead Connector [A]
- Neutral Position Switch Lead Connector [B]
- Engine Ground Lead [C]
- Oil Pressure Switch Lead [D]
- Oil Hoses [E]

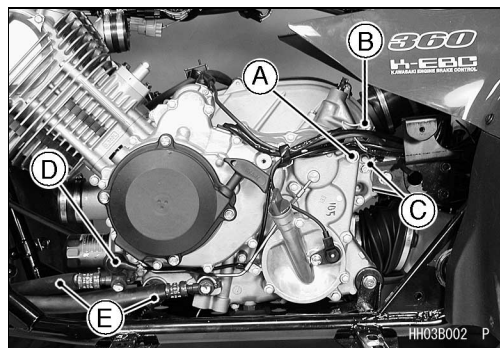

● Remove:

- Engine Mounting Upper Bolt [A]
- Engine Mounting Front Bracket [B]

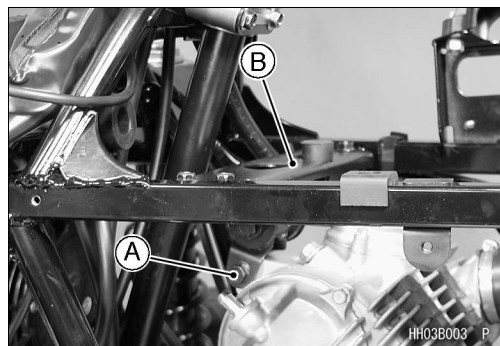

● Remove:

- Boot [A]
- Engine Mounting Bolts [B]
- Engine Mounting Rear Brackets [C]

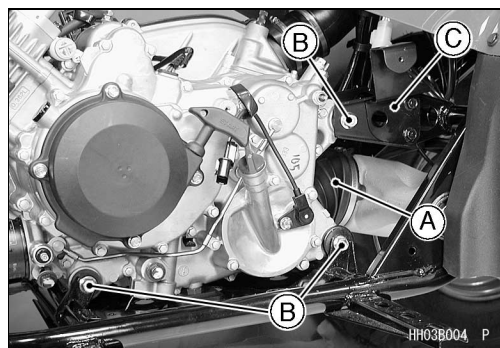

Engine Removal/Installation

- Put a tape to protect the frame.
- Move the engine forward to remove the drive shaft [A] from the rear propeller shaft joint [B].
- Remove the engine from the left side.

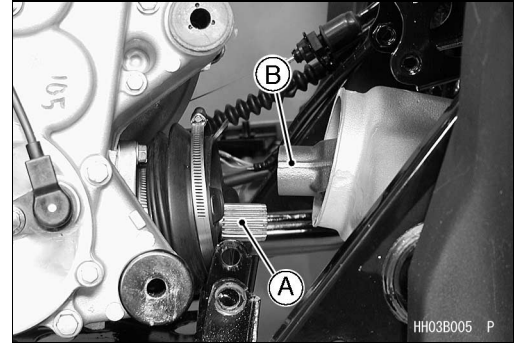

Engine Installation

- Be sure the damper [A] is in place.

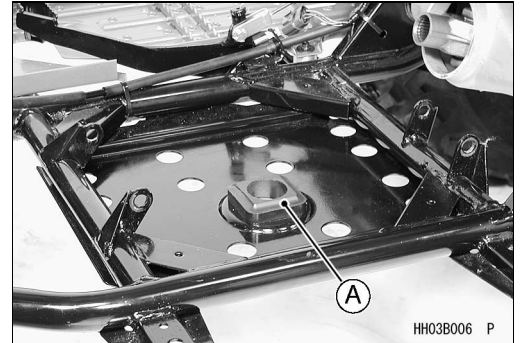

- Roll up the boot [A] toward the engine.

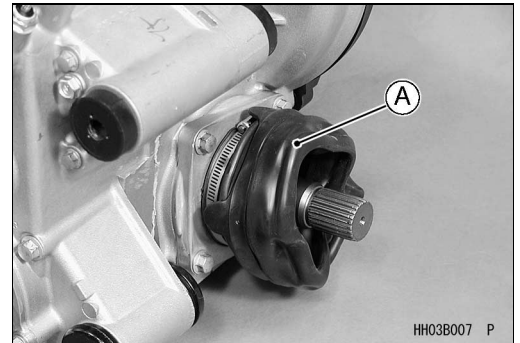

- Insert the drive shaft in the rear propeller shaft joint [A].
- Tighten:
 - Torque - Lower Engine Mounting Bracket Bolts: 25 N·m (2.5 kgf·m, 18 ft·lb)**
 - Lower Engine Mounting Bolts and Nuts: 42 N·m (4.3 kgf·m, 31 ft·lb)**
 - Upper Engine Mounting Bracket Bolt and Nut: 42 N·m (4.3 kgf·m, 31 ft·lb)**
 - Upper Engine Mounting Bolt and Nut: 25 N·m (2.5 kgf·m, 18 ft·lb)**

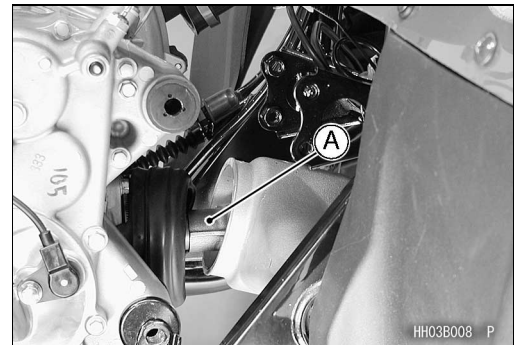

Crankshaft / Transmission

Table of Contents

- Exploded View.....9-2
- Specifications.....9-6
- Crankcase.....9-7
 - Crankcase Disassembly.....9-7
 - Crankcase Assembly.....9-7
- Crankshaft/Balancer Shaft and Connection Rod.....9-10
 - Crankshaft/Balancer Shaft Removal.....9-10
 - Crankshaft/Balancer Shaft Installation.....9-10
 - Crankshaft Disassembly.....9-10
 - Crankshaft Assembly.....9-11
 - Connecting Rod Big End Seizure.....9-12
 - Connecting Rod Big End Radial Clearance.....9-12
 - Connecting Rod Big End Side Clearance.....9-12
 - Crankshaft Alignment.....9-13
 - Connecting Rod Bend/Twist.....9-14
- Transmission.....9-15
 - Shift Lever Removal.....9-15
 - Shift Lever Installation.....9-16
 - Transmission Removal.....9-18
 - Transmission Installation.....9-19
 - Shift Fork Bending.....9-21
 - Shift Fork/Gear and Shifter Groove Wear.....9-21
 - Transmission and Shift Mechanism Inspection.....9-21
- Ball Bearing, Needle Bearing, and Oil Seal.....9-23
 - Ball and Needle Bearing Replacement.....9-23
 - Ball and Needle Bearing Wear.....9-23
 - Oil Seal Inspection.....9-23

9-2 CRANKSHAFT / TRANSMISSION

Exploded View

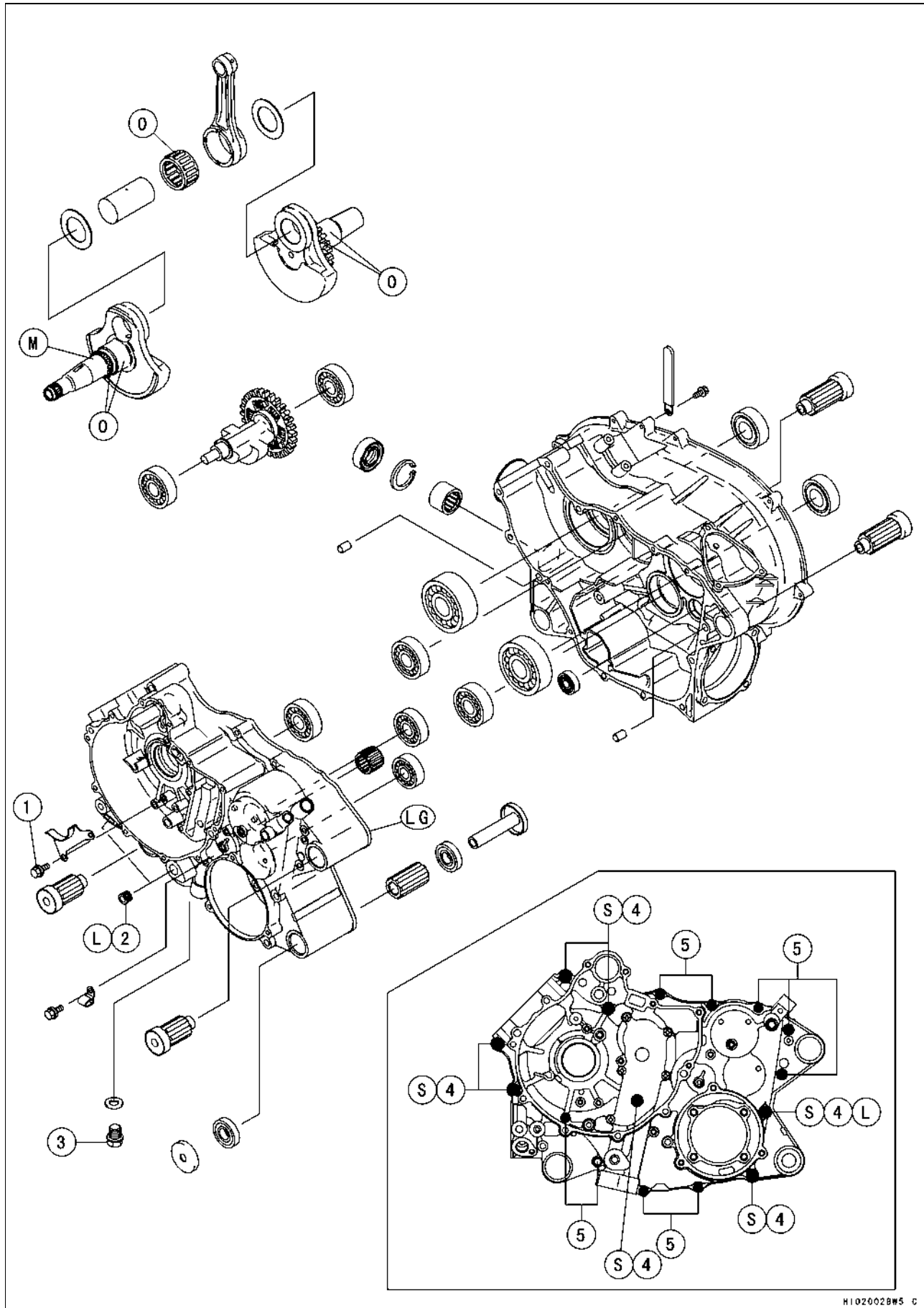

CRANKSHAFT / TRANSMISSION 9-3

Exploded View

No.	Fastener	Torque			Remarks
		N·m	kgf·m	ft·lb	
1	Camshaft Chain Guard Bolts	8.8	0.9	78 in·lb	
2	Oil Line Plugs	23	2.3	17	L
3	Engine Drain Plug	20	2.0	14	
4	Crankcase Bolts (M8)	20	2.0	14	S, L(1)
5	Crankcase Bolts (M6)	8.8	0.9	78 in·lb	

L: Apply a non-permanent locking agent.

M: Apply molybdenum disulfide grease.

O: Apply engine oil.

LG: Apply liquid gasket (Three Bond 1215, Gray).

S: Follow the specific tightening sequence.

9-4 CRANKSHAFT / TRANSMISSION

Exploded View

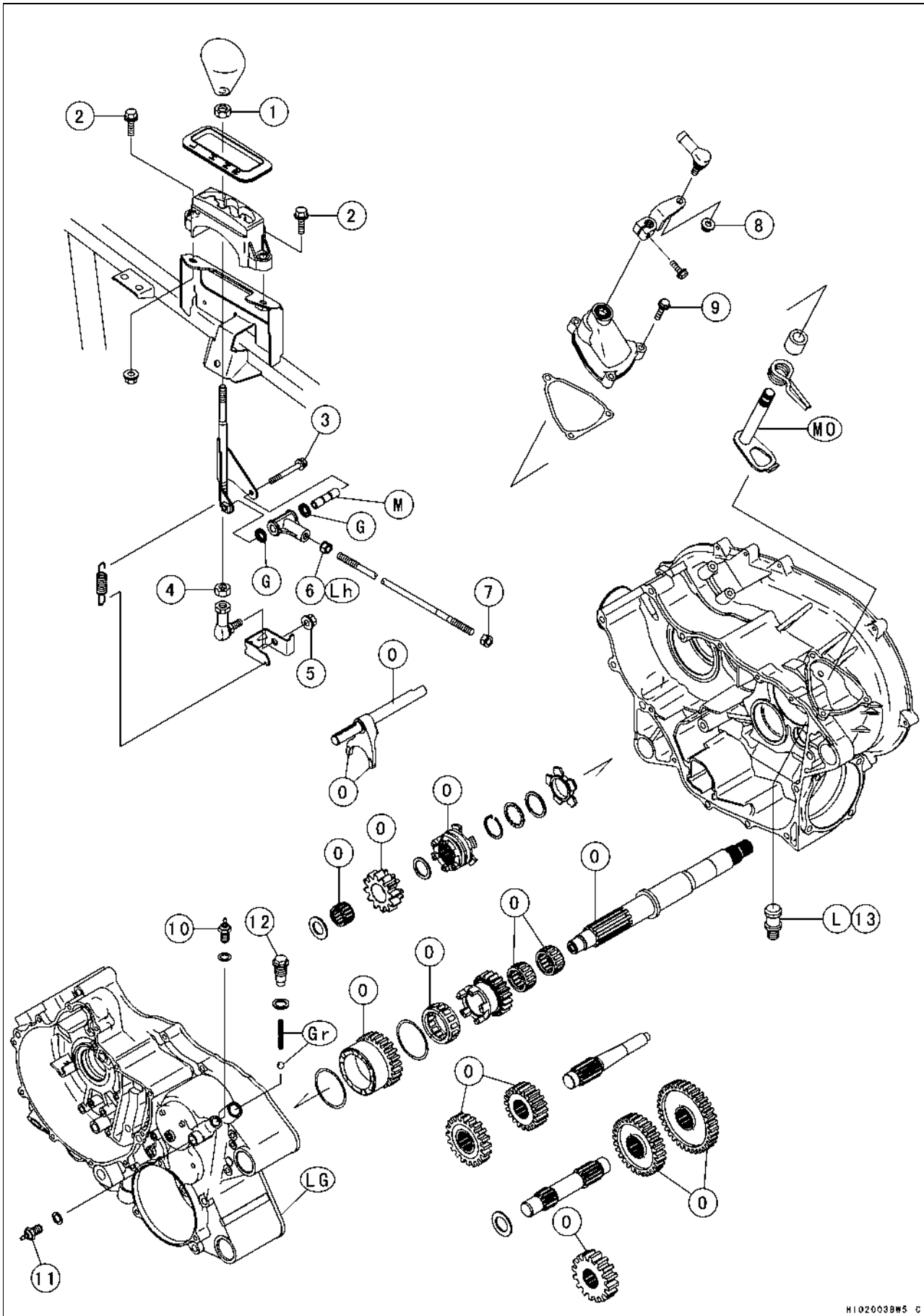

CRANKSHAFT / TRANSMISSION 9-5

Exploded View

No.	Fastener	Torque			Remarks
		N·m	kgf·m	ft·lb	
1	Grip Hold Nut	9.8	1.0	87 in·lb	
2	Shift Lever Assembly Bracket Bolts	20	2.0	14	
3	Tie-Rod End Bolt	9.8	1.0	87 in·lb	
4	Tie-Rod End Locknut	20	2.0	14	
5	Shift Lever Assembly Nut	20	2.0	14	
6	Tie-Rod End Front Locknut	9.8	1.0	87 in·lb	Lh
7	Tie-Rod End Rear Locknut	9.8	1.0	87 in·lb	
8	Tie-Rod End Nut	20	2.0	14	
9	Shift Shaft Cover Bolts	8.8	0.9	78 in·lb	
10	Neutral Position Switch	15	1.5	11	
11	Reverse Position Switch	15	1.5	11	
12	Shift Shaft Positioning Bolt	25	2.5	18	
13	Shift Shaft Spring Bolt	25	2.5	18	L

G: Apply grease for oil seal and O-ring.

L: Apply a non-permanent locking agent.

M: Apply molybdenum disulfide grease.

O: Apply engine oil.

MO: Apply molybdenum disulfide oil.

Lh: Left-hand Threads

Gr: Apply grease.

LG: Apply liquid gasket (Three Bond 1215, Gray)

9-6 CRANKSHAFT / TRANSMISSION

Specifications

Item	Standard	Service Limit
Crankshaft, Connecting Rods:		
Connecting rod big end radial clearance	0.008 ~ 0.020 mm (0.0003 ~ 0.0008 in.)	0.07 mm (0.003 in.)
Connecting rod big end side clearance	0.25 ~ 0.35 mm (0.0098 ~ 0.0138 in.)	0.6 mm (0.024 in.)
Crankshaft runout		
Left	TIR 0.03 mm (0.0012 in.) or less	TIR 0.08 mm (0.0032 in.)
Right	TIR 0.04 mm (0.0016 in.) or less	TIR 0.10 mm (0.0039 in.)
Connecting rod bend	under 0.05/100 mm (0.002/3.94 in.)	0.2/100 mm (0.008/3.94 in.)
Connecting rod twist	under 0.15/100 mm (0.006/3.94 in.)	0.2/100 mm (0.008/3.94 in.)
Crankshaft main journal/bearing clearance	0.025 ~ 0.052 mm (0.001 ~ 0.002 in.)	---
Crankshaft main journal diameter	37.989 ~ 38.000 mm (1.4956 ~ 1.4961 in.)	37.97 mm (1.4949 in.)
Crankcase main bearing bore diameter	38.025 ~ 38.041 mm (1.4970 ~ 1.4977 in.)	38.07 mm (1.4988 in.)
Transmission:		
Shift fork ear thickness	5.9 ~ 6.0 mm (0.2322 ~ 0.2362 in.)	5.8 mm (0.228 in.)
Shifter groove width	6.05 ~ 6.15 mm (0.2382 ~ 0.2421 in.)	6.25 mm (0.2460 in.)

Special Tools - Outside Circlip Pliers: 57001-144

Bearing Driver Set: 57001-1129

Oil Seal Driver: 57001-1517

Sealant - Kawasaki Bond (Liquid Gasket - Gray): 92104-1065

Three Bond: 1215 (Gray)

Crankcase

Crankcase Disassembly

- Remove:
 - Engine (see Engine Removal/Installation chapter)
 - Drive and Driven Pulleys (see Converter System chapter)
 - Starter Motor (see Electrical System chapter)
 - Oil Filter
 - Starter Clutch Gear (see Electrical System chapter)
 - Oil Pump (see Engine Lubrication System chapter)
 - Piston (see Engine Top End chapter)
 - Camshaft Chain (see Engine Top End chapter)
 - Shift Shaft Positioning Bolt [A], Washer, Spring, and Steel Ball Damper [B]
- Remove:
 - Crankcase Bolts (M6) [A]
 - Crankcase Bolts (M8) [B]
- Wrap the teeth on the sprocket [C] by taping for protecting the bushing in the crankcase.
- Using the pry points [D] split the crankcase halves.
- Lift off the left crankcase half.

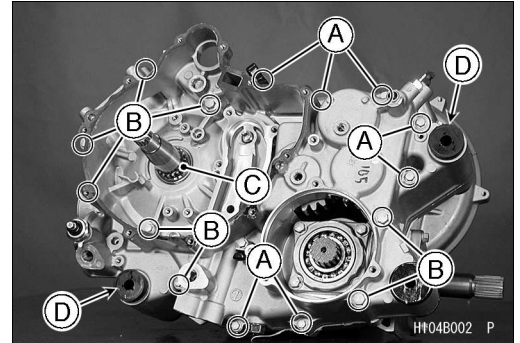
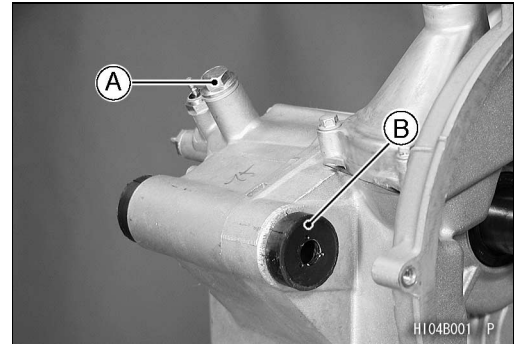

Crankcase Assembly

CAUTION

Right and left crankcase halves are machined at the factory in the assembled state, so the crankcase halves must be replaced as a set.

NOTE

- Be certain that all parts are cleaned thoroughly before assembly.
- Blow through all oil passages with compressed air to clear any blockage in the crankcase halves and crankshaft.

WARNING

Clean the engine parts in a well-ventilated area, and take care that there are no sparks or flame anywhere near the working area; this includes any appliance with a pilot light. Do not use gasoline or a low-flash point solvent to clean parts. A fire or explosion could result.

- Apply a small amount of engine oil to the transmission gears, bearings, and shift forks.
- Be sure the mating surfaces of the crankcase halves are clean and dry.
- Press and insert the new ball bearings until they are bottomed.
 - Special Tool - Bearing Driver Set: 57001-1129**
 - [A] Ball Bearing
 - [B] Ball Bearing (sealed side towards crankcase)
- Press and insert the new needle bearing so that the bearing surface is flush with the end of the hole.
 - [C] Needle Bearing
- Apply engine oil to the bearings.
- Install:
 - Oil Pressure Relief Valve [D] (see Engine Lubrication System chapter)

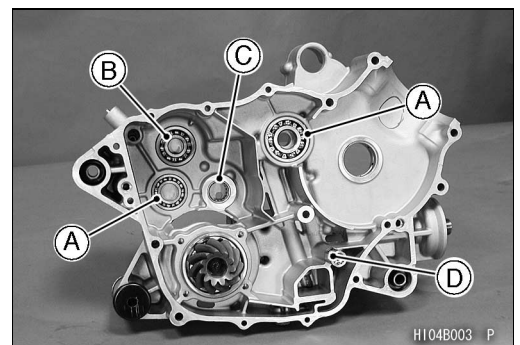
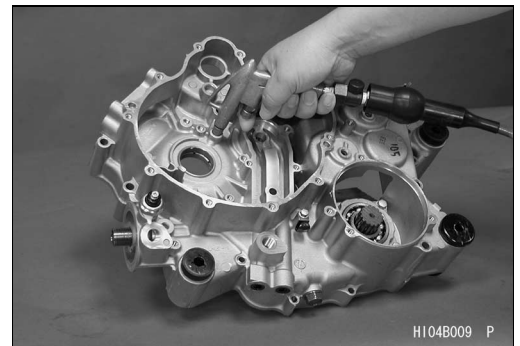

9-8 CRANKSHAFT / TRANSMISSION

Crankcase

- Press and insert the new ball bearings [A] until they are bottomed.
Special Tool - Bearing Driver Set: 57001-1129
- Press and insert the new needle bearing so that the bearing surface is flush with the end of the hole.
[B] Needle Bearing
- Apply engine oil to the bearings.

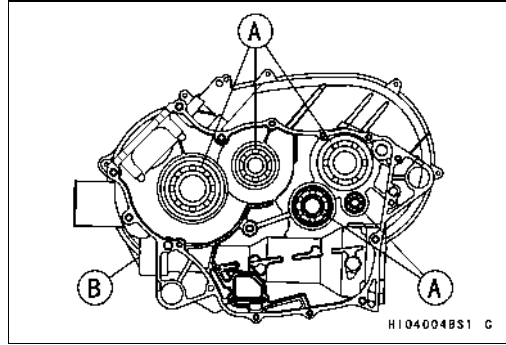

- Be sure the following parts are in place in the right crankcase half.
Crankshaft and Balancer Shaft (see Crankshaft/Balancer Shaft Installation)
Transmission Shafts and Shift Rod [A]
Spacers [B]
Oil Screen [C]
Dowel Pins [D]

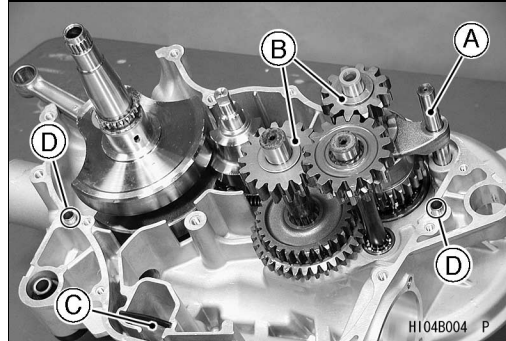

- Apply liquid gasket [A] to mating surface of the left crankcase half.
Sealant - Three Bond: 1215 (Gray)

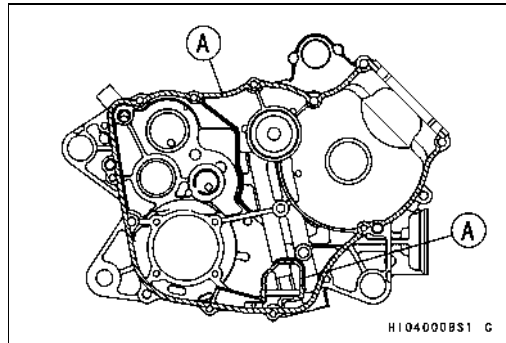

- Install:
Oil Pump (see Engine Lubrication System chapter)
- Apply a non-permanent locking agent:
Left Crankcase Bolt (M8) [3]
- Tighten the left crankcase bolts (M8) following the tightening sequence [1~7].

Torque - Crankcase Bolts (M8): 20 N·m (2.0 kgf·m, 14 ft·lb)

- [1] L = 85 mm (3.35 in.)
- [2, 5, 6, 7] L = 75 mm (2.95 in.)
- [3, 4] L = 110 mm (4.33 in.)

- Tighten:

Torque - Crankcase Bolts (M6): 8.8 N·m (0.9 kgf·m, 78 in·lb)

- [A] L = 40 mm (1.57 in.)
- [B] L = 65 mm (2.56 in.)
- [C] L = 85 mm (3.35 in.)

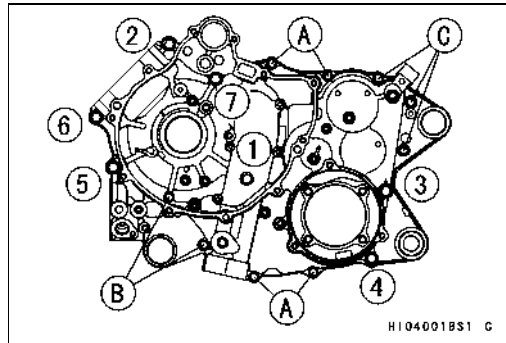

Crankcase

- Press the oil seal [A] into the crankcase [B] with the oil seal driver. [C] 3 mm (0.12 in.)

Special Tool - Oil Seal Driver [D]: 57001-1517

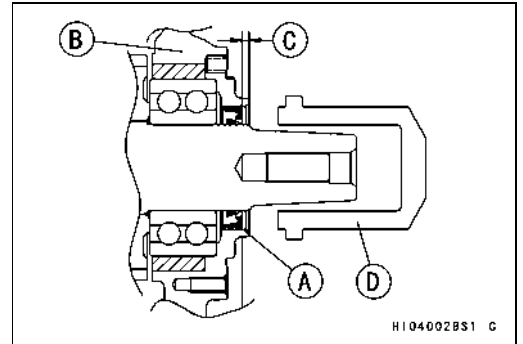

- Apply grease to the steel ball [A] and spring [B].

- Install:
 - Steel Ball
 - Spring
 - Washer (C)
 - Shift Shaft Positioning Bolt [D]

- Tighten:

Torque - Shift Shaft Positioning Bolt: 25 N·m (2.5 kgf·m, 18 ft·lb)

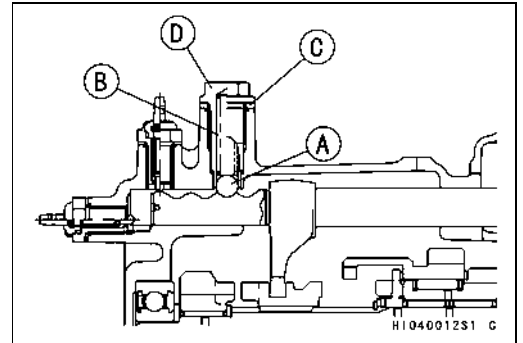

- Check:

Crankshaft, driven shaft and output shaft turn freely.

- ★ If any of the shaft do not turn freely, split the crankcase to locate the problem.

9-10 CRANKSHAFT / TRANSMISSION

Crankshaft/Balancer Shaft and Connection Rod

Crankshaft/Balancer Shaft Removal

- Split the crankcase (see Crankcase Disassembly).
- Remove:
 - Balancer Shaft [A]
 - Transmission Shaft Assembly
- Remove the crankshaft [B] from the crankcase using a press.

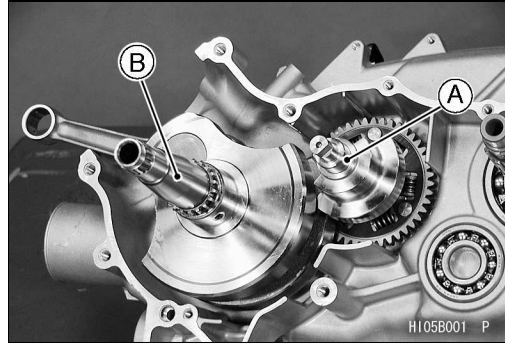

Crankshaft/Balancer Shaft Installation

- The left shaft [A] of the crankshaft is longer than the right shaft [B].
- Apply engine oil to the both main journals and teeth of the sprocket.
- Insert the right crankshaft tapered end (the shorter end) into the right crankcase using a press.

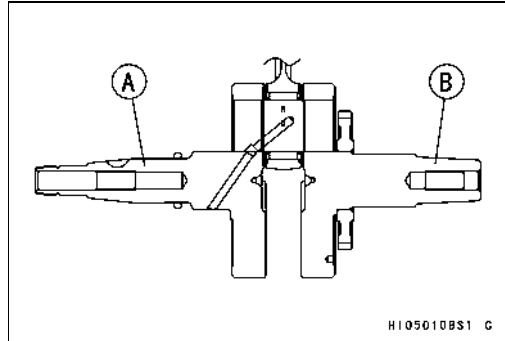

- Align the punch mark [A] on the balancer shaft gear with the punch marks [B] on the crankshaft gear as shown.

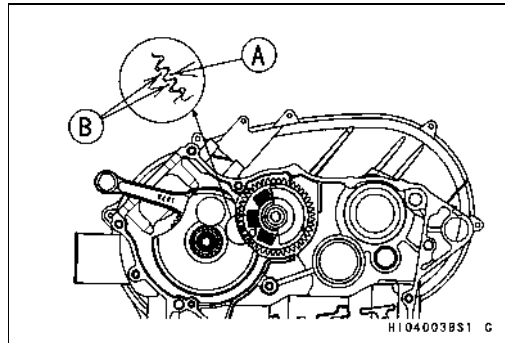

Crankshaft Disassembly

CAUTION

Since assembly of the crankshaft demands exacting tolerances, the disassembly and reassembly of the crankshaft should only be performed by experienced mechanics with the necessary tools and equipment.

The crankshaft left main bearing, chain sprocket, and left crankshaft are available separately as spare parts, however, it is recommended that the crankshaft assembly be replaced rather than attempting to replace the components.

- Press the crankpin out of the crank halves to separate the crank halves, connecting rod, spacers, crankpin needle bearing, and crankpin.

Crankshaft/Balancer Shaft and Connection Rod

Crankshaft Assembly

- Apply engine oil to the needle bearing.
- Press the crank halves onto the crankpin, noting the crankpin direction until connecting rod side clearance is within specification (see Connecting Rod Big End Side Clearance).
- Make sure oil passages of the crank and crankpin are lined up during assembly.
- Check that the connecting rod radial clearance is within specification (see Connecting Rod Big End Radial Clearance).
- Adjust crankshaft runout until runout is within specification (see Crankshaft Alignment).

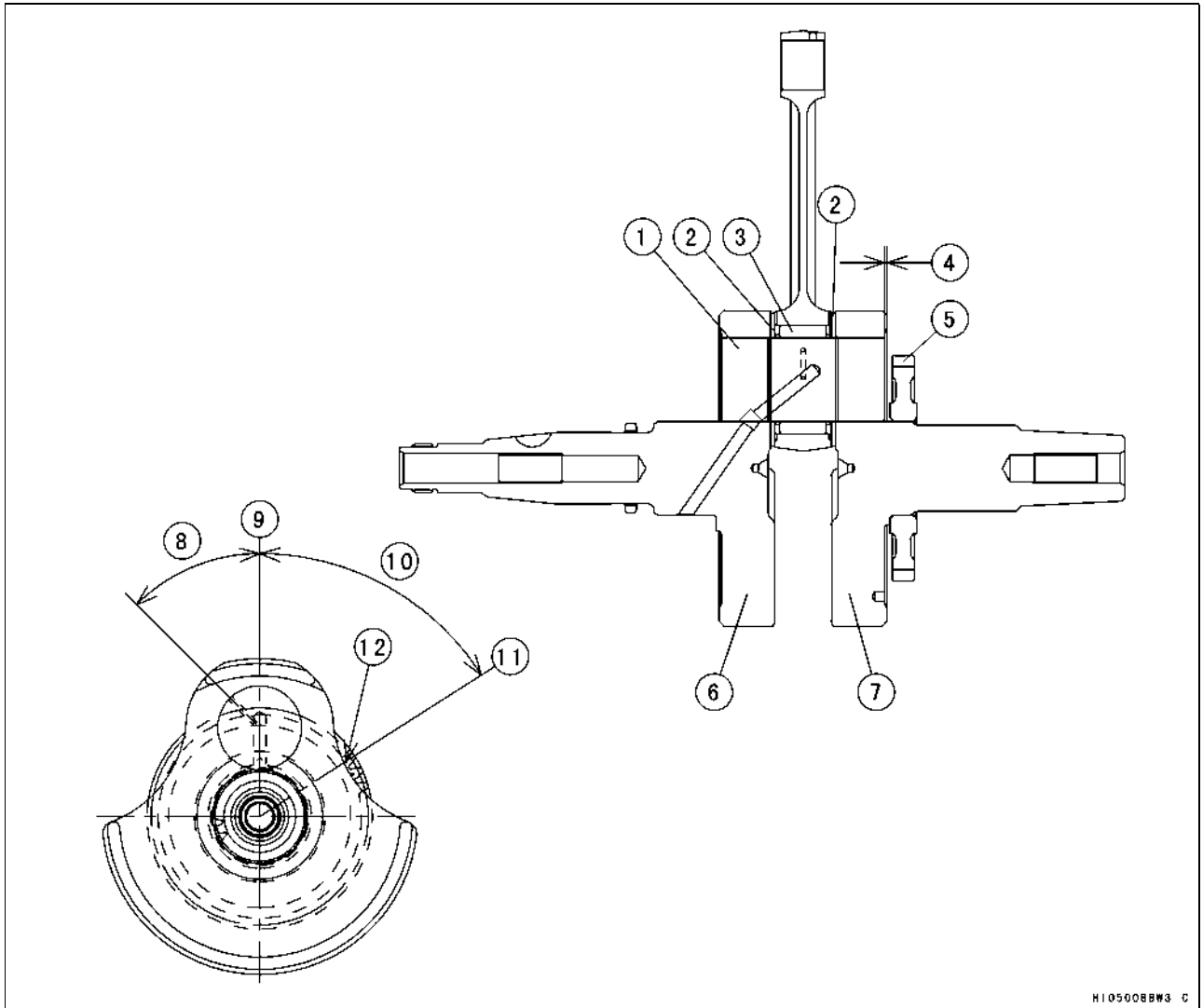

H1050088W3 C

1. Crankpin
2. Spacers
3. Crankpin Needle Bearing
4. $1.1 \pm 0.35 \text{ mm}$ ($0.043 \pm 0.014 \text{ in.}$)
(From web end to crankpin end)
5. Balancer Gear
6. Left Crankshaft

7. Right Crankshaft
8. $45^\circ \pm 1^\circ$
9. Center of Crankpin
10. $57^\circ 25' \pm 30'$
11. Center of Sprocket Tooth
12. Punch Mark

9-12 CRANKSHAFT / TRANSMISSION

Crankshaft/Balancer Shaft and Connection Rod

Connecting Rod Big End Seizure

- In the case of serious seizure with damage to the crank halves, the crankshaft must be replaced.
- ★ If the seizure was less severe, disassemble the crankshaft and replace the crankpin, needle bearing, and connecting rod.

Connecting Rod Big End Radial Clearance

- Set the crankshaft on V blocks, and place a dial gauge [A] against the connecting rod big end.
- Push [B] the connecting rod first towards the gauge and then in the opposite direction. The difference between the two gauge readings is the radial clearance.
- ★ If the radial clearance exceeds the service limit, the crankshaft assembly must be replaced or disassembled and the crankpin, needle bearing, and connecting rod big end examined or wear.

Connecting Rod Big End Radial Clearance

- Standard:** 0.008 ~ 0.020 mm (0.0003 ~ 0.0008 in.)
- Service Limit:** 0.07 mm (0.003 in.)

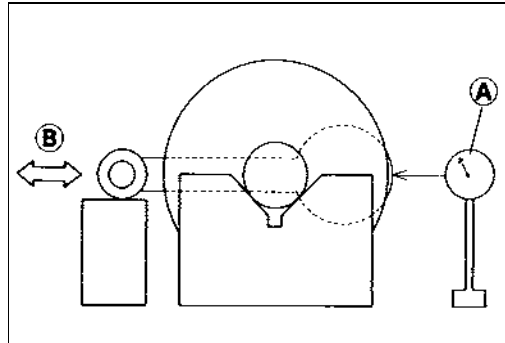

Connecting Rod Big End Side Clearance

- Set the crankshaft on V blocks.
- Measure the side clearance [A] of the connecting rod with a thickness gauge.
- ★ If the big end side clearance exceeds the service limit, the crankshaft assembly must be replaced or disassembled and the connecting rod and thrust washers visually inspected for wear.

Connecting Rod Big End Side Clearance

- Standard:** 0.25 ~ 0.35 mm (0.0098 ~ 0.0138 in.)
- Service Limit:** 0.6 mm (0.024 in.)

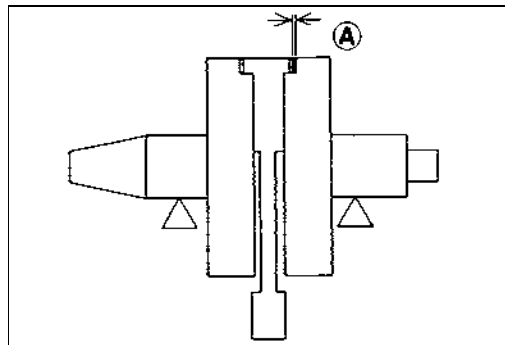

Crankshaft/Balancer Shaft and Connection Rod

Crankshaft Alignment

- With the crankshaft on V blocks, turn the crankshaft slowly and measure runout at each of the locations shown.

[A] 8 mm (0.315 in.)

[B] 25.5 mm (1.004 in.)

Crankshaft Runout

Left Half [C]

Standard: TIR 0.03 mm (0.0012 in.) or less

Service Limit: TIR 0.08 mm (0.0032 in.)

Right Half [D]

Standard: TIR 0.04 mm (0.0016 in.) or less

Service Limit: TIR 0.10 mm (0.0039 in.)

- ★ If runout at either location exceeds the service limit, align the crankshaft so that runout is within the service limits.
- In the case of horizontal misalignment, strike the projecting crankshaft half with a plastic, soft lead, or brass hammer as shown.
- Recheck the runout and repeat the process until the runout is within service limits.
- Vertical misalignment is corrected either by driving a wedge in between the crank halves, or by squeezing the crank halves in a vise, depending on the nature of the misalignment.
- In the case of both horizontal and vertical misalignment, correct the horizontal misalignment first.
- Recheck big end side clearance after aligning crankshaft (see Connecting Rod Big End Side Clearance).

NOTE

- If crankshaft alignment cannot be corrected by the above method, replace the crankpin or crank halves as required.

CAUTION

Don't hammer the flywheel at the point [A].

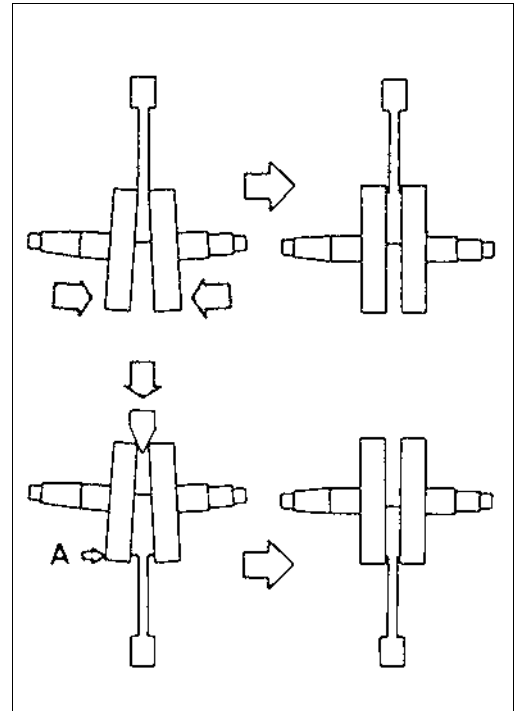
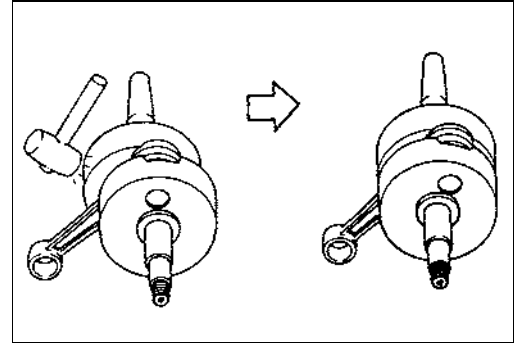
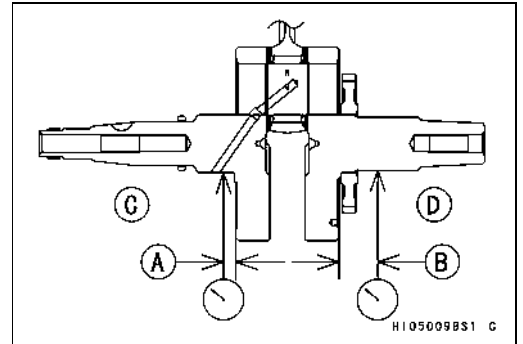

9-14 CRANKSHAFT / TRANSMISSION

Crankshaft/Balancer Shaft and Connection Rod

Connecting Rod Bend/Twist

- Measure the connecting rod bend.
- Set the crankshaft in an alignment jig or in V blocks on a surface plate.
- Select an arbor of the same diameter as the piston pin and at least 100 mm (3.94 in.) long, and insert the arbor through the connecting rod small end.
- With the connecting rod held vertically, use a height gauge to measure the difference in the height of the arbor above the surface plate over a 100 mm (3.94 in.) length to determine the amount of connecting rod bend.
- ★ If connecting rod bend exceeds the service limit, the connecting rod must be replaced.

Connecting Rod Bend

- Standard:** Under 0.05/100 mm (0.002/3.94 in.)
- Service Limit:** 0.2/100 mm (0.008/3.94 in.)

- Measure the connecting rod twist.
- With the crankshaft still in the alignment jig, hold the connecting rod horizontally and measure the amount that the arbor varies from being parallel with the crankshaft over a 100 mm (3.94 in.) length of the arbor to determine the amount of connecting rod twist.
- ★ If connecting rod twist exceeds the service limit, the connecting rod must be replaced.

Connecting Rod Twist

- Standard:** Under 0.15/100 mm (0.006/3.94 in.)
- Service Limit:** 0.2/100 mm (0.008/3.94 in.)

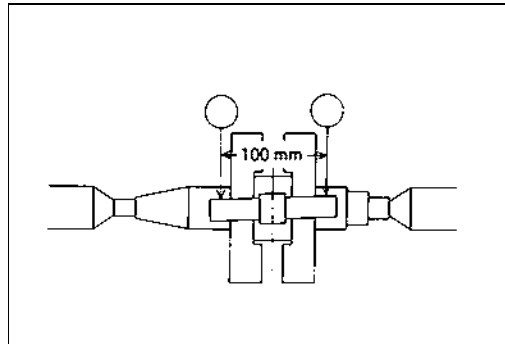
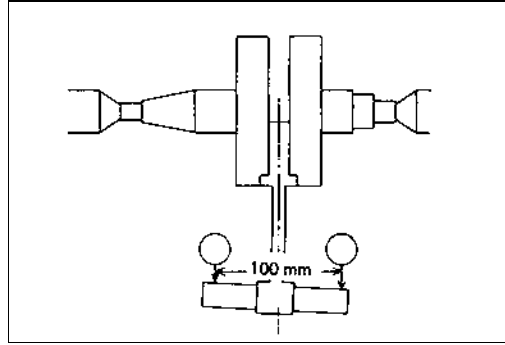

Transmission

Shift Lever Removal

- Set the shift lever in the neutral position.
- Remove:
 - Air Cleaner Housing (see Fuel System chapter)
 - Shift Shaft Lever Bolt [A]
- Remove the shift shaft lever [B] from the shift shaft.

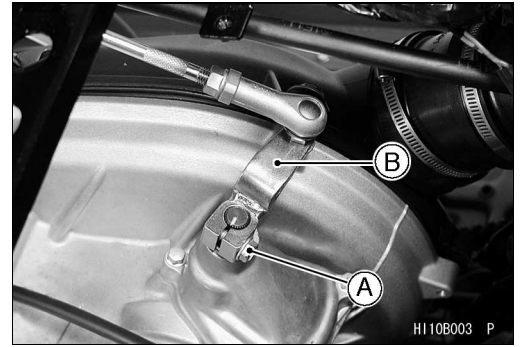

- Remove:
 - Nut [A]
 - Shift Lever Assembly [B]

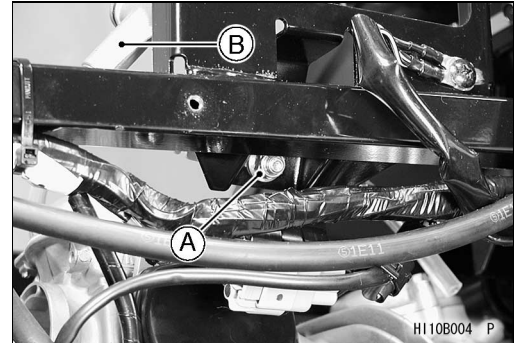

- Remove:
 - Tie-Rod End Bolt [A]
 - Tie-Rod [B]

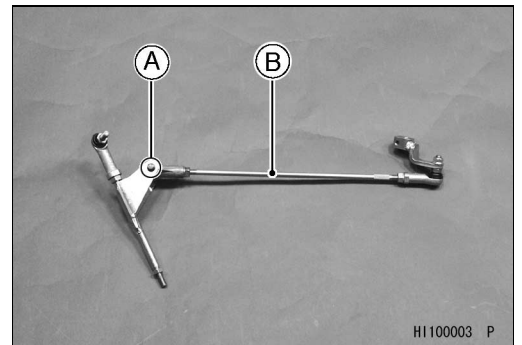

- Remove:
 - Oil Seals [A]
 - Collar [B]

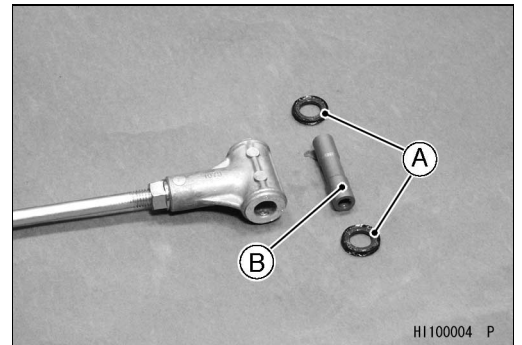

9-16 CRANKSHAFT / TRANSMISSION

Transmission

Shift Lever Installation

- Twist the tie-rod end [A] and tie-rod locknut [B] to bottom of the screw and then turn back to dimension with $77^\circ \pm 10^\circ$ [C] as shown.
- Tighten the locknut against the tie-rod end:
Torque - Tie-Rod End Locknut: 20 N·m (2.0 kgf·m, 14 ft·lb)
- Apply molybdenum disulfide grease:
Outside of Tie-Rod End Collar [D]
- Apply grease to the oil seals, and install them.
- Tighten:
Torque - Tie-Rod End Bolt [E]: 9.8 N·m (1.0 kgf·m, 87 in·lb)

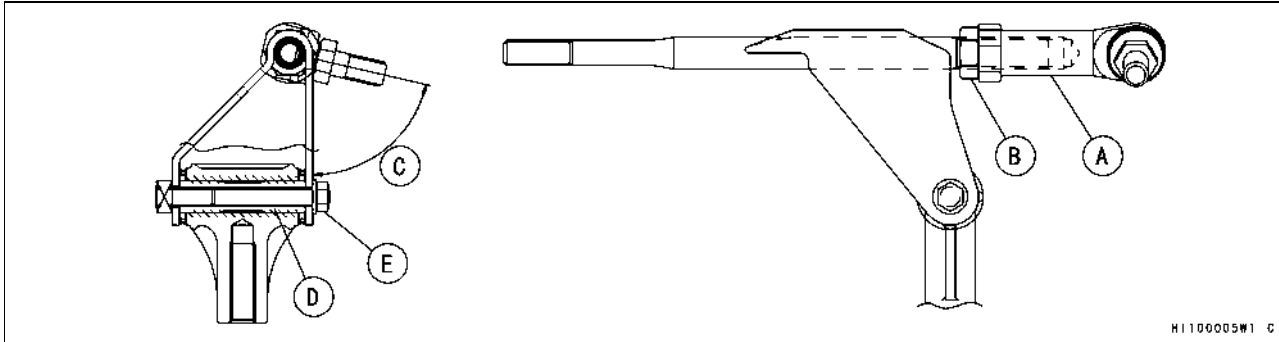

- Align the mark [A] on the shaft end with the slit [B] of the shift shaft lever.
- Position the shift shaft lever end [C] on the boss-center [D] of the crankcase.
- Install:
Bracket [E]
Shift Lever Assembly Nut [F]
- Tighten:
Torque - Shift Lever Assembly Nut: 20 N·m (2.0 kgf·m, 14 ft·lb)
Tie-Rod End Nut [G]: 20 N·m (2.0 kgf·m, 14 ft·lb)

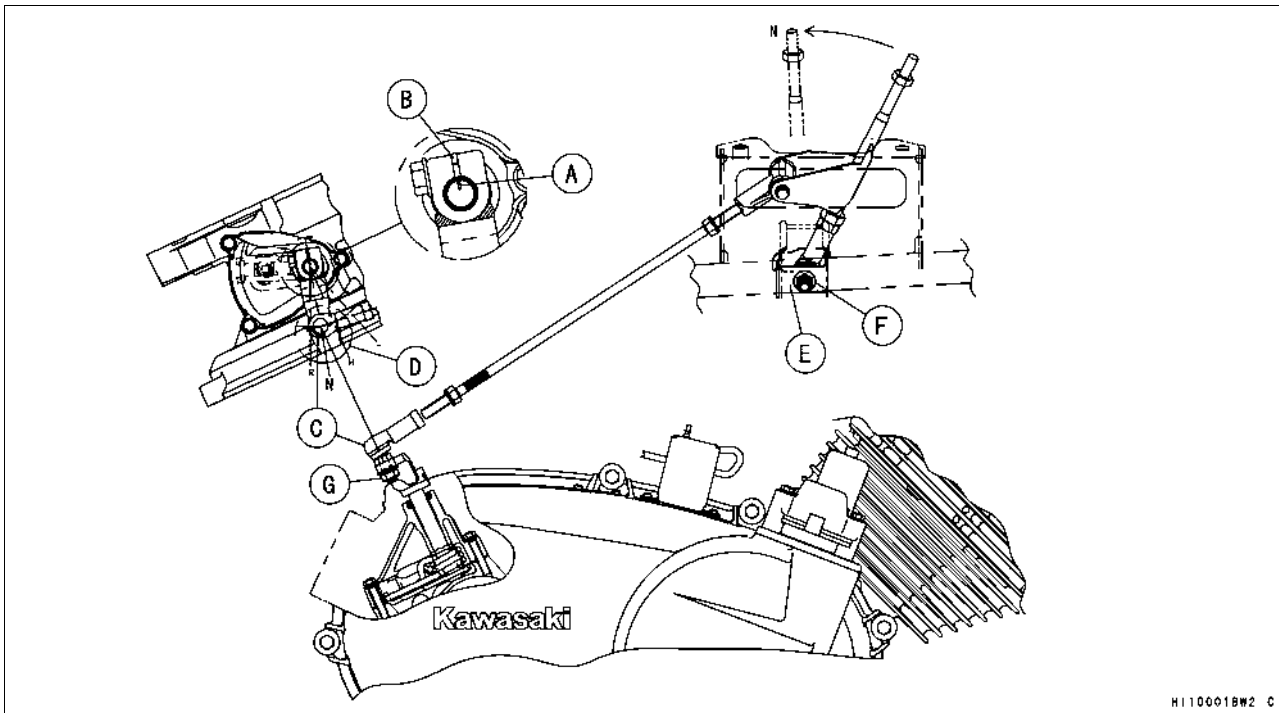

Transmission

- Install:
 - Guide [A]
- Tighten:
 - Torque - Shift Lever Assembly Bracket Bolts [B]: 20 N·m (2.0 kgf·m, 14 ft·lb)**
- Set the lever assembly in the neutral position [C] while turning the tie-rod [D].

NOTE

- Do not turn the shift shaft [E] when setting the lever assembly on neutral position.
- Turn the tie-rod until the rod [F] of the shift lever assembly contact with the guide [G], and then the tie-rod can be turned until 1/8. At that time, the clearance [H] which can be made between the rod and the guide is 0 ~ -0.5 mm (0 ~ -0.02 in.).
- This clearance is a setting range for the neutral position.
- Tighten:
 - Torque - Tie-Rod End Rear Locknut [I]: 9.8 N·m (1.0 kgf·m, 87 in·lb)**
- Holding the rear locknut, and tighten the front locknut [J].
 - Torque - Tie-Rod End Front Locknut : 9.8 N·m (1.0 kgf·m, 87 in·lb)**

NOTE

- The front locknut has left-hand threads.
- Do not lean the tie-rod rear end after tightening the front locknut.
 - Right [K]
 - Wrong [L]
- Check that the shift lever moves from right to left smoothly.
- Install:
 - Spring [M]
 - Trim Seal [N]
- Align the mark [O] of the grip [P] with the projection [Q] on the guide.
- Tighten:
 - Torque - Grip Hold Nut [R]: 9.8 N·m (1.0 kgf·m, 87 in·lb)**

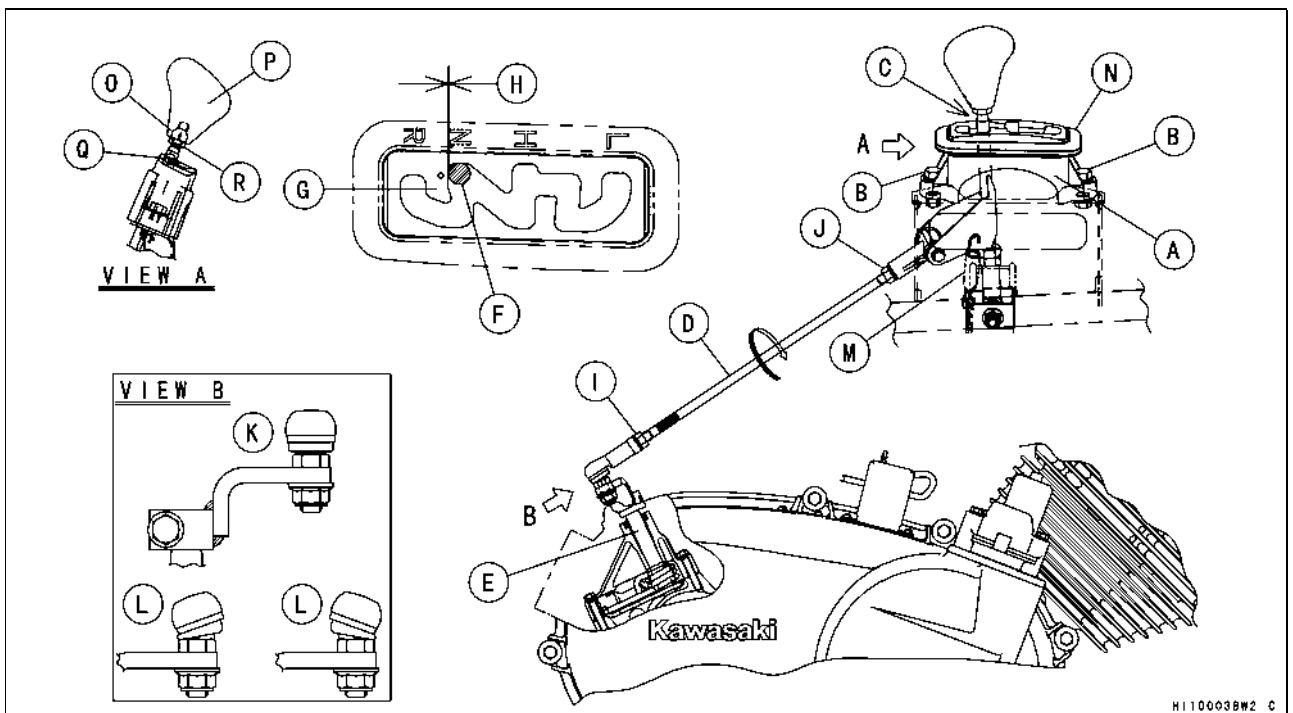

9-18 CRANKSHAFT / TRANSMISSION

Transmission

Transmission Removal

- Sprit the crankcase (see Crankcase Disassembly).

- Remove:

- Shift Shaft Cover Bolts [A]
- Shift Shaft Cover [B]

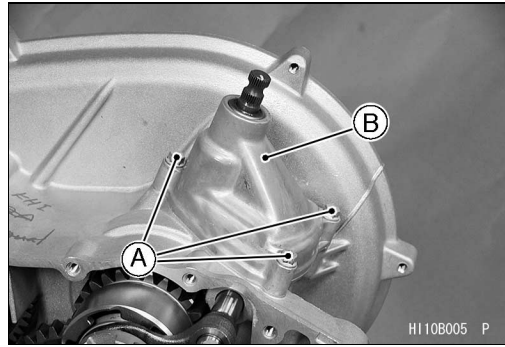

- Remove:

- Shift Shaft Spring Bolt [A]
- Shift Shaft [B]

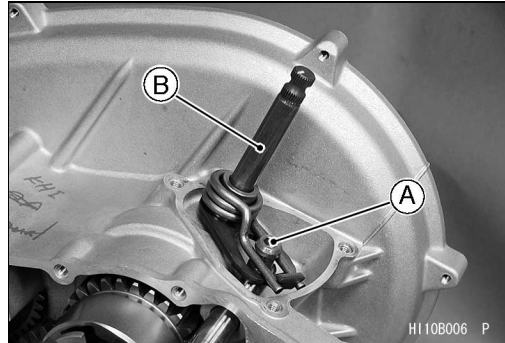

- Remove:

- Reverse Idle Shaft [A]
- Spacer [B]
- Reverse Drive Gear [C], Needle Bearing, and Spacer
- Shifter [D]
- Shift Rod [E]

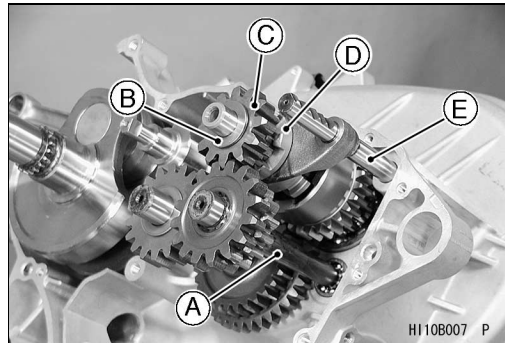

- Remove:

- Circlip [A]

Special Tool - Outside Circlip Pliers: 57001-144

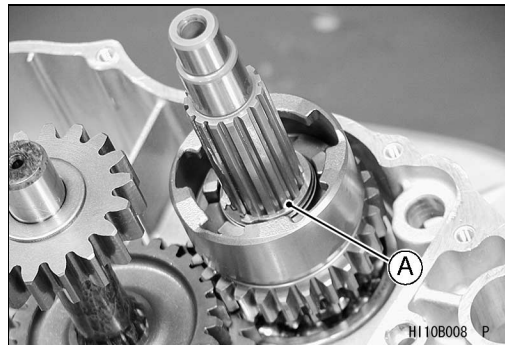

- Remove:

- Spacer [A]
- Idle Gear Assembly [B]
- Washers and Spacer [C]
- Low and High Gears [D]

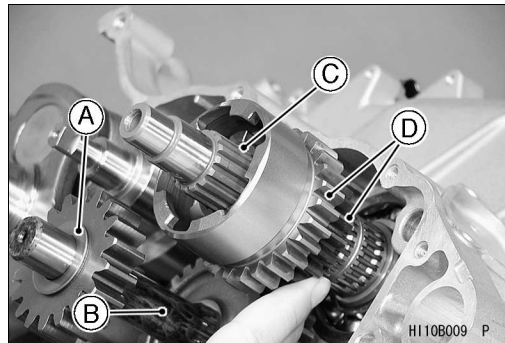

Transmission

- Remove:
Needle Bearings [A]
- Remove the driven shaft [B] from the crankcase using a press.

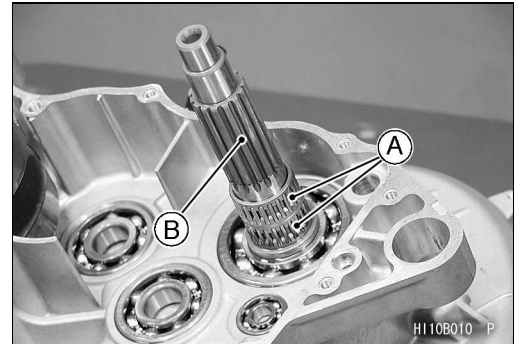

Transmission Installation

- Insert the driven shaft in the crankcase until it is bottomed using a press.
- Apply engine oil to the needle bearings and install them.
- Install the following parts on the low gear [A].
Needle Bearings [B]
Spacer [C] (P/No. 92026-1599, 48.2 x 54.3 x 1.0)
High Gear [D]

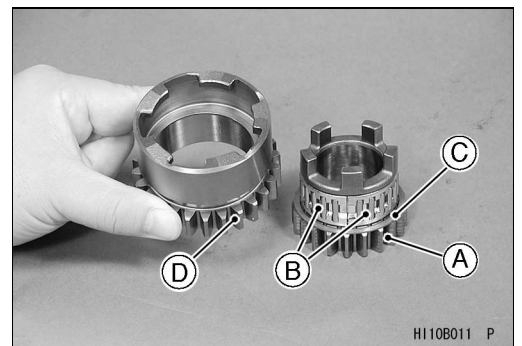

- Install:
Idle Shaft [A] with Gear Assembly [B]
Spacer [C]
Spacer [D] (P/No. 92026-1599, 48.2 x 54.3 x 1.0)
- Install the spacer [E] so that the stepped side [F] faces outward.

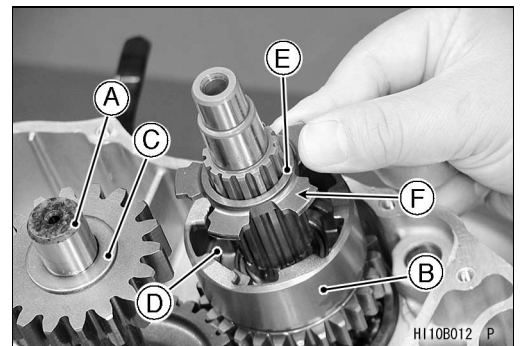

- Install:
Spacer [A]
Toothed Washer [B]
Circlip
- **Special Tool - Outside Circlip Pliers: 57001-144**

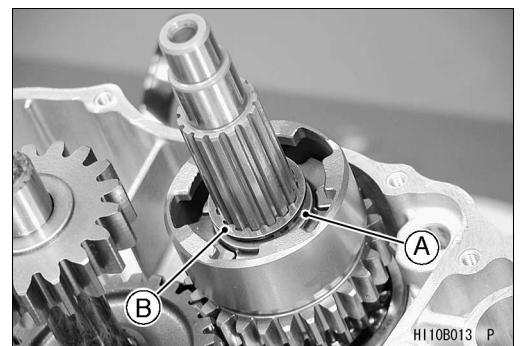

9-20 CRANKSHAFT / TRANSMISSION

Transmission

- Apply engine oil:
Shift Rod and Shift Fork Ear [A]
Needle Bearing
- Install:
Shift Rod [B] with Shifter [C]
Spacer [D]
Needle Bearing [E]

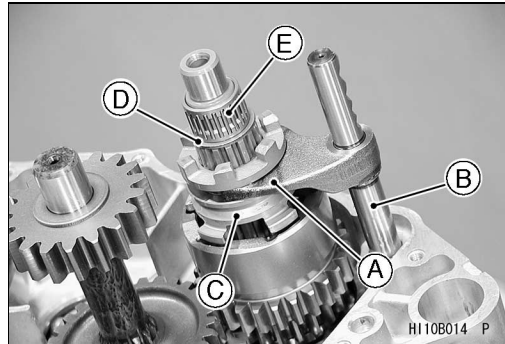

- Install:
Reverse Drive Gear [A]
Spacer [B]
Reverse Idle Shaft [C]

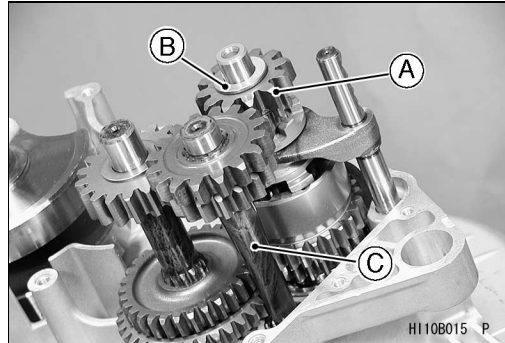

- Apply molybdenum disulfide oil to the shift shaft [A].
- Install:
Shift Shaft Spring Bolt [B]
Spring [C]
Guide [D]
- Apply a non-permanent locking agent:
Shift Shaft Spring Bolt
- Tighten:
Torque - Shift Shaft Spring Bolt: 25 N·m (2.5 kgf·m, 18 ft·lb)

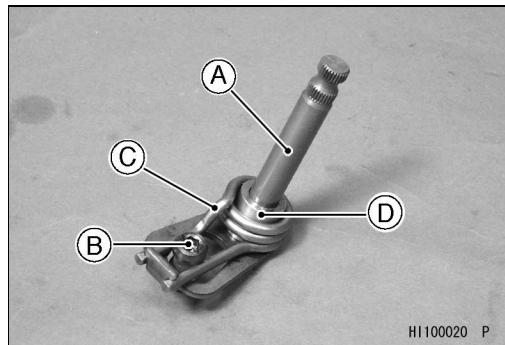

- When a new bushing [A] and oil seal [B] are installed in the shift shaft cover [C], press and insert the new bushing and oil seal so that their surfaces are flush with the end of the each hole.

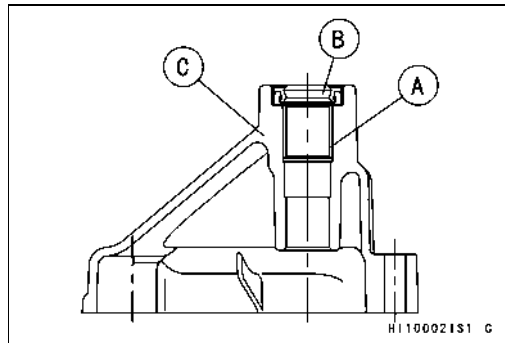

- Install:
Shift Shaft Cover
- Tighten:
Torque - Shift Shaft Cover Bolts: 8.8 N·m (0.9 kgf·m, 78 in·lb)

Transmission

Shift Fork Bending

- Visually inspect the shift fork.
- ★ If the fork is bent, replace the shift rod with a new one. A bent fork could cause difficulty in shifting, or allow the transmission to jump out of gear when under power.
[A] 90°

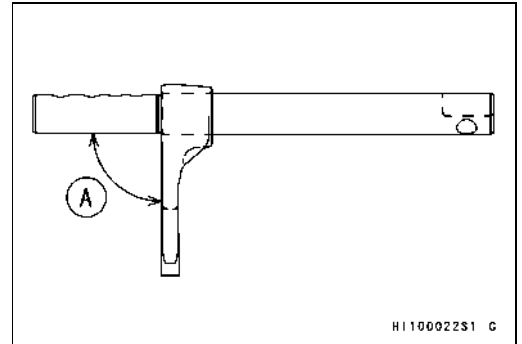

Shift Fork/Gear and Shifter Groove Wear

- Measure the thickness of the shift fork ears [A], and measure the width [B] of the gear groove and shifter.
- ★ If the thickness of a shift fork ear is less than the service limit, the shift rod must be replaced.

Shift Fork Ear Thickness

Standard: 5.9 ~ 6.0 mm (0.2322 ~ 0.2362 in.)

Service Limit: 5.8 mm (0.228 in.)

- ★ If the groove is worn over the service limit, the shifter must be replaced.

Shifter Groove Width

Standard: 6.05 ~ 6.15 mm (0.2382 ~ 0.2421 in.)

Service Limit: 6.25 mm (0.2460 in.)

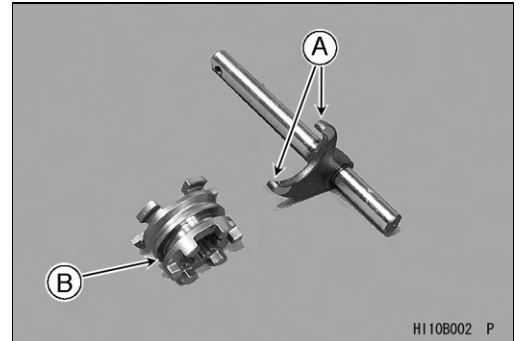

Transmission and Shift Mechanism Inspection

- Visually inspect:
 - Gears
 - Dogs on Gear and Shifter
- ★ If they are damaged or worn excessively, replace them.



Ball Bearing, Needle Bearing, and Oil Seal

Ball and Needle Bearing Replacement

CAUTION

Do not remove the ball or needle bearings unless it is necessary. Removal may damage them.

- Using a press or puller, remove the ball bearing and/or needle bearing outer race.

NOTE

- *In the absence of the above mentioned tools, satisfactory results may be obtained by heating the case to approximately 93°C (200°F) max., and tapping the bearing in or out.*

CAUTION

Do not heat the case with a torch. This will warp the case. Soak the case in oil and heat the oil.

- Using a press and the bearing driver set [A], install the new bearing or outer race until it stops at the bottom of its housing.

Special Tool - Bearing Driver Set: 57001-1129

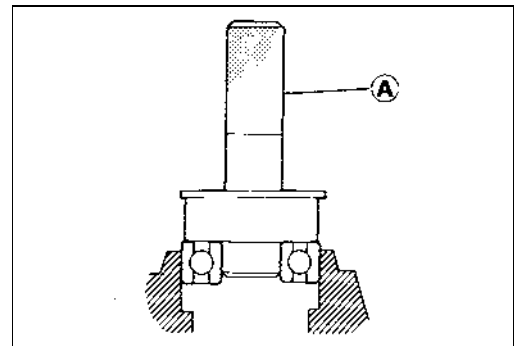

Ball and Needle Bearing Wear

CAUTION

Do not remove the bearings for inspection. Removal may damage them.

- Check the ball bearings.
 - Since the ball bearings are made to extremely close tolerances, the wear must be judged by feel rather than measurement. Clean each bearing in a high flash-point solvent, dry it (do not spin the bearing while it is dry), and oil it with engine oil.
 - Spin [A] the bearing by hand to check its condition.
 - ★ If the bearing is noisy, does not spin smoothly, or has any rough spots, replace it.
- Check the needle bearings.
 - The rollers in a needle bearing normally wear very little, and wear is difficult to measure. Instead of measuring, inspect the bearing for abrasion, color change, or other damage.
 - ★ If there is any doubt as to the condition of a needle bearing, replace it.

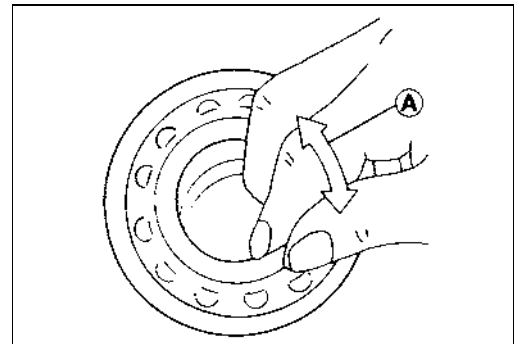

Oil Seal Inspection

- Inspect the oil seals.
- ★ Replace it if the lips are misshapen, discolored (indicating that the rubber has deteriorated), hardened or otherwise damaged.

Wheels / Tires

Table of Contents

Exploded View.....	10-2
Specifications.....	10-4
Wheel Alignment.....	10-5
Steering Centering Inspection.....	10-5
Steering Centering Adjustment.....	10-5
Toe-in Inspection.....	10-6
Toe-in Adjustment.....	10-6
Wheels (Rims).....	10-7
Wheel Removal.....	10-7
Wheel Installation.....	10-7
Wheel (Rim) Inspection.....	10-7
Wheel (Rim) Replacement.....	10-8
Tires.....	10-9
Tire Removal.....	10-9
Tire Installation.....	10-9
Tire Inspection.....	10-10
Front Hub.....	10-11
Front Hub Removal.....	10-11
Front Hub Installation.....	10-11
Front Hub Disassembly/Assembly.....	10-11
Rear Hub.....	10-12
Rear Hub Removal.....	10-12
Rear Hub Installation.....	10-12
Rear Hub Disassembly/Assembly.....	10-12

10-2 WHEELS / TIRES

Exploded View

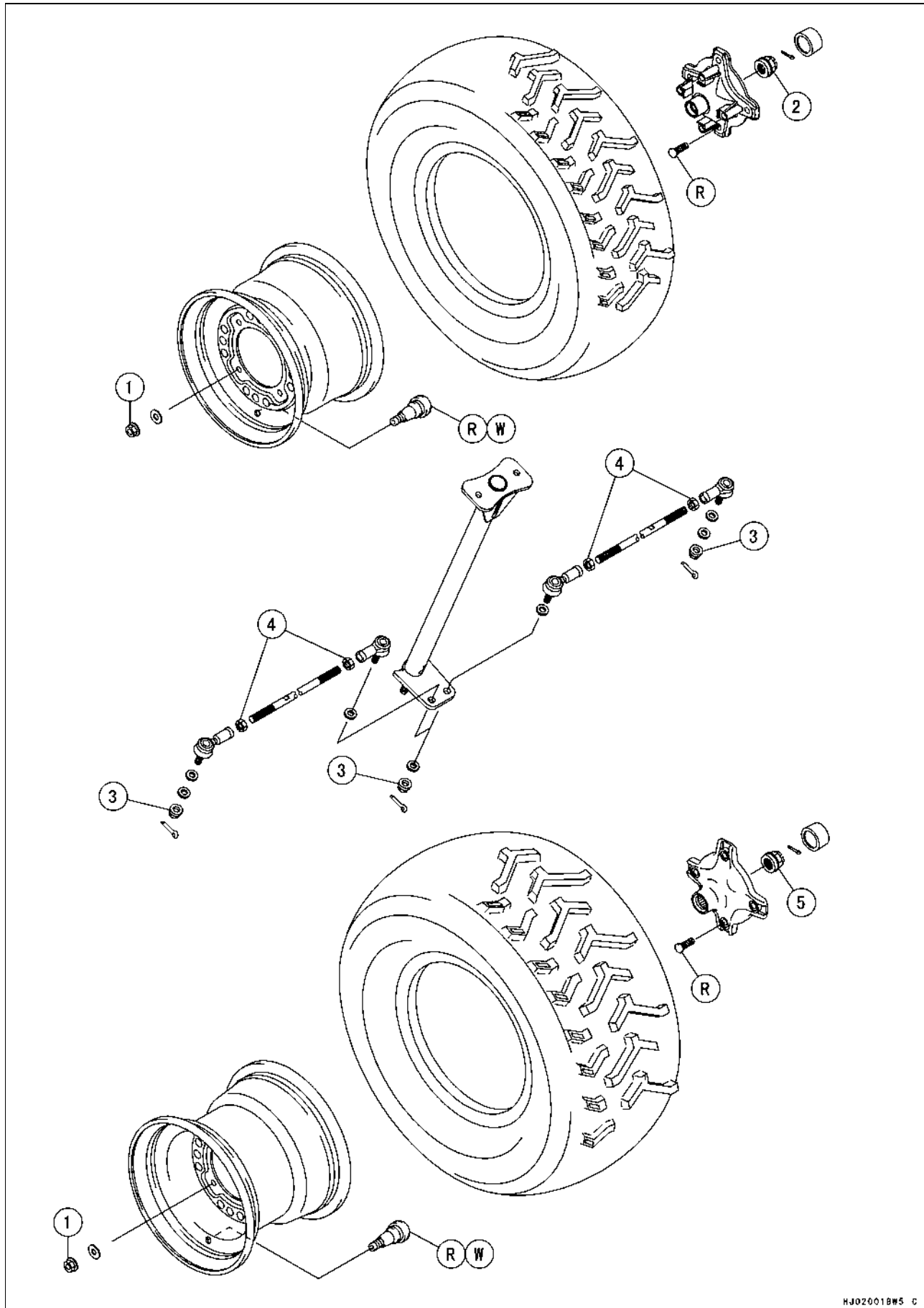

Exploded View

No.	Fastener	Torque			Remarks
		N·m	kgf·m	ft·lb	
1	Wheel Nuts	52	5.3	38	S
2	Front Axle Nuts	196	20	145	
3	Tie-Rod End Nuts	42	4.3	31	
4	Tie-Rod Adjusting Sleeve Locknuts	37	3.8	27	
5	Rear Axle Nuts	265	27	195	

W: Apply water or soap and water solution.

R: Replacement Parts

10-4 WHEELS / TIRES

Specifications

Item	Standard	Service Limit
Wheel Alignment: Toe-in of front wheels:	0 ~ 20 mm (0 ~ 0.79 in.) at 1G	---
Tires:		
Standard tire: Front	AT 25 × 8-12 DUNLOP, KT121, Tubeless	---
Rear	AT 25 × 10-12 DUNLOP, KT405C/KT127A, Tubeless	---
Tire air pressure (when cold): Front	35 kPa (0.35 kgf/cm ² , 5.0 psi)	---
Rear	35 kPa (0.35 kgf/cm ² , 5.0 psi)	---
Maximun tire air pressure (to seat beads, when cold)	250 kPa (2.5 kgf/cm ² , 36 psi)	---
Tire tread depth: Front	---	3 mm (0.12 in.)
Rear	---	4 mm (0.16 in.)

Special Tool - Jack: 57001-1238

Wheel Alignment

Toe-in is the amount that the front wheels are closer together in front than at the rear at the axle height. When there is toe-in, the distance A (Rear) is the greater than B (Front) as shown.

The purpose of toe-in is to prevent the front wheels from getting out of parallel at any time, and to prevent any slipping or scuffing action between the tires and the ground. If toe-in is incorrect, the front wheels will be dragged along the ground, scuffing and wearing the tread knobs.

Caster and camber are build-in and require no adjustment.

$A \text{ (Rear) } - B \text{ (Front) } = \text{Amount of Toe-in}$
 (Distance A and B are measured at axle height with the vehicle sitting on the ground, or at 1G.)

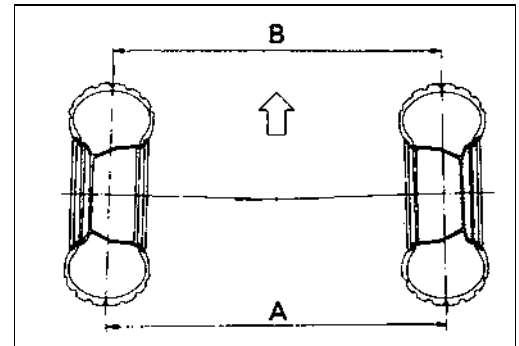

Steering Centering Inspection

- Test ride the vehicle.
- ★ If the handlebar is straight when the vehicle is traveling in a straight line, go on to the Toe-in Inspection procedure.
- ★ Otherwise, go on to the Steering Centering Adjustment procedure.

Steering Centering Adjustment

- Hold a straightedge [A] against the rear wheel rim on one side at axle height.

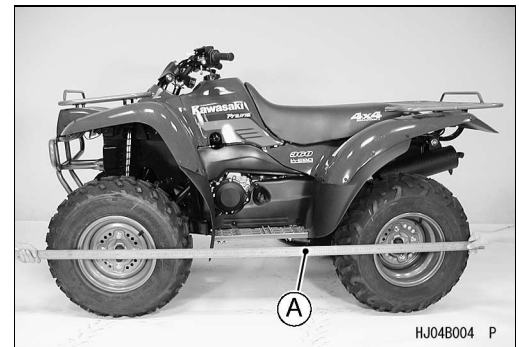

- With the handlebar straight ahead, loosen the locknuts [A] [B] and turn the tie-rod adjusting sleeve [C] until the front wheel on that side is parallel to the straightedge.

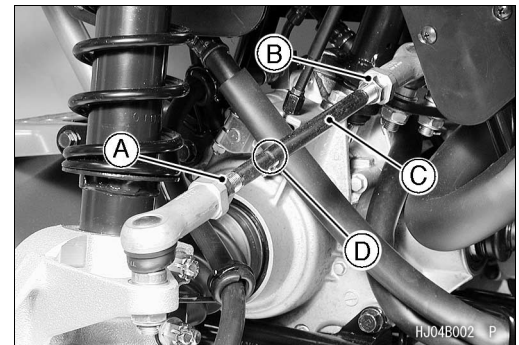

NOTE

- The locknut [A] near the flattened area [D] on the tie-rod has left-hand threads. Turn the wrench clockwise for loosening.

CAUTION

Adjust the tie-rod so that the visible thread length [A] is even on both ends of the tie-rod, or the threads could be damaged.

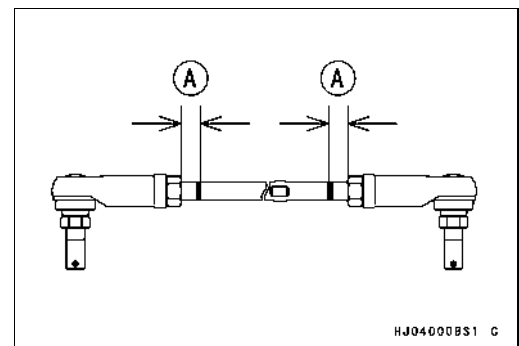

10-6 WHEELS / TIRES

Wheel Alignment

- Repeat the straightedge procedure on the other side of the vehicle. Now the front wheels are parallel to each other and to the center line of the vehicle.
 - Front Wheel [A]
 - Vehicle Center Line [B]
 - Parallel each other [C]
 - Straightedges [D]
 - Rear Wheels [E]
- Go on to the Toe-in Inspection procedure.

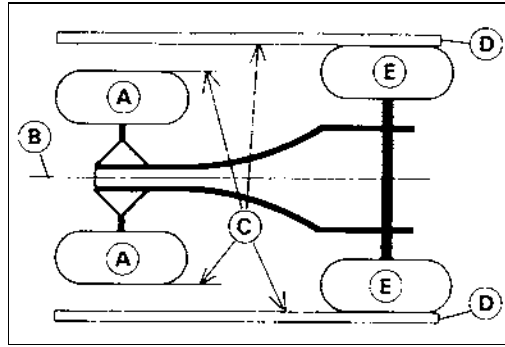

Toe-in Inspection

- Apply a heavy coat of chalk or a paint line near the center of the front tires.
- Using a needle nose scriber, make a thin mark near the center of the chalk coating while turning the wheel.

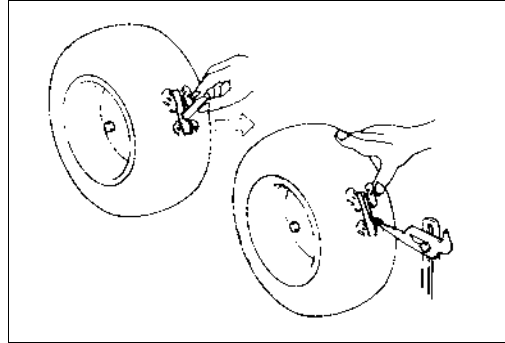

- With the front wheels on the ground, set the handlebar straight ahead.
- At the level of the axle height, measure the distance between the scribed or painted lines for both front and rear of the front tires.
- Subtract the measurement of the front from the measurement of the rear to get the toe-in.
- ★ If the toe-in is not in the specified range, go on to the Toe-in Adjustment procedure.



Toe-in of Front Wheels

Standard: 0 ~ 20 mm (0 ~ 0.79 in.) at 1G

Toe-in Adjustment

- Loosen the locknuts [A] [B] and turn the adjusting sleeves [C] the same number of turns on both sides to achieve the specified toe-in.

NOTE

- The locknut [A] near the flattened area [D] on the tie-rod has left-hand threads. Turn the locknut clockwise for loosening.
- The toe-in will be near the specified value, if the tie-rod length [E] is 315 ± 0.7 mm (12.4 ± 0.03 in.) on each tie-rod.

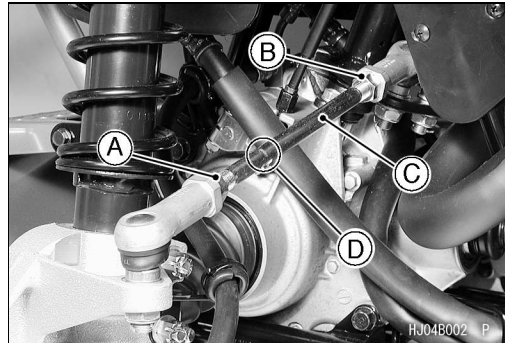

CAUTION

Adjust the tie-rod length so that the visible thread length [F] is even on both ends of the tie-rod. Uneven thread length could cause tie-rod damage.

- Check the toe-in.
- Tighten:
 - Torque - Tie-Rod Adjusting Sleeve Locknuts: 37 N·m (3.8 kgf·m, 27 ft·lb)
- Test ride the vehicle.

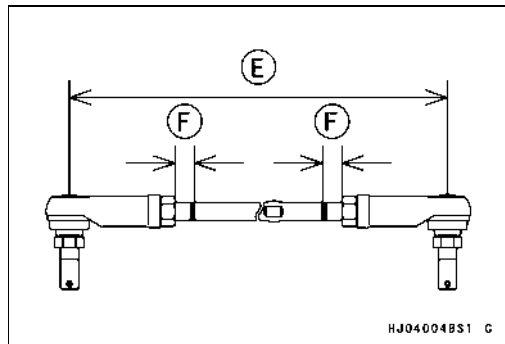

HJ04004B51 G

Wheels (Rims)

Wheel Removal

- Loosen the wheel nuts [A].
- Support the vehicle on a stand or a jack so that the wheels are off the ground.

Special Tool - Jack: 57001-1238

- Remove:
 - Wheel Nuts
 - Wheel

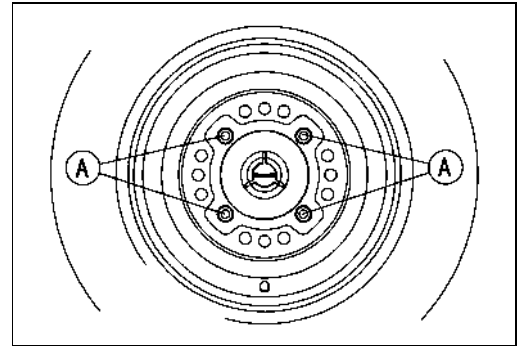

Wheel Installation

- Check the tire rotation mark [A] on the tire, and install the wheel accordingly.

NOTE

- The direction of the tire rotation [B] is shown by an arrow on the tire sidewall.

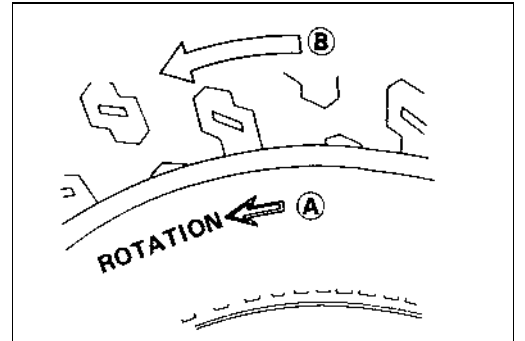

- Position the wheel so that the air valve [A] is toward the outside of the vehicle.
- Tighten the wheel nuts in a criss-cross pattern.

Torque - Wheel Nuts: 52 N·m (5.3 kgf·m, 38 ft·lb)

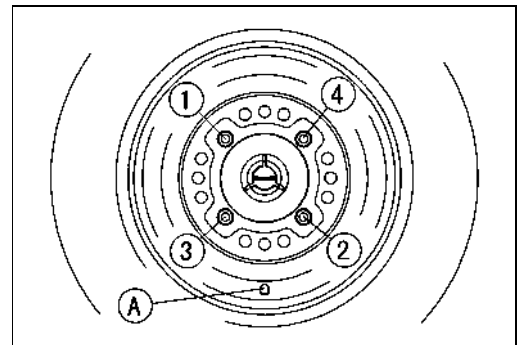

Wheel (Rim) Inspection

- Examine both sides of the rim for dents [A]. If the rim is dented, replace it.

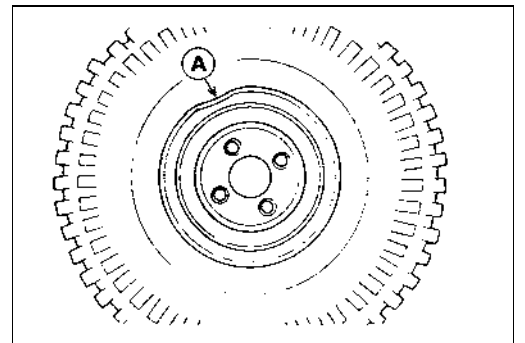

- ★ If the tire is removed, inspect the air sealing surfaces [A] of the rim for scratches or nicks. Smooth the sealing surfaces with fine emery cloth if necessary.

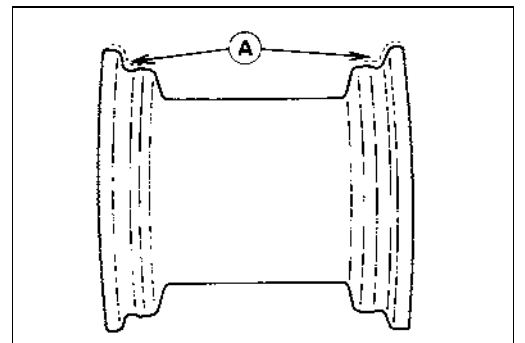

10-8 WHEELS / TIRES

Wheels (Rims)

Wheel (Rim) Replacement

- Remove the wheel (see Wheel Removal).
- Disassemble the tire from the rim (see Tire Removal).
- Remove the air valve and discard it.

CAUTION

Replace the air valve whenever the tire is replaced. Do not reuse the air valve.

- Plastic Cap [A]
- Valve Core [B]
- Stem Seal [C]
- Valve Stem [D]
- Valve Seat [E]
- Valve Opened [F]

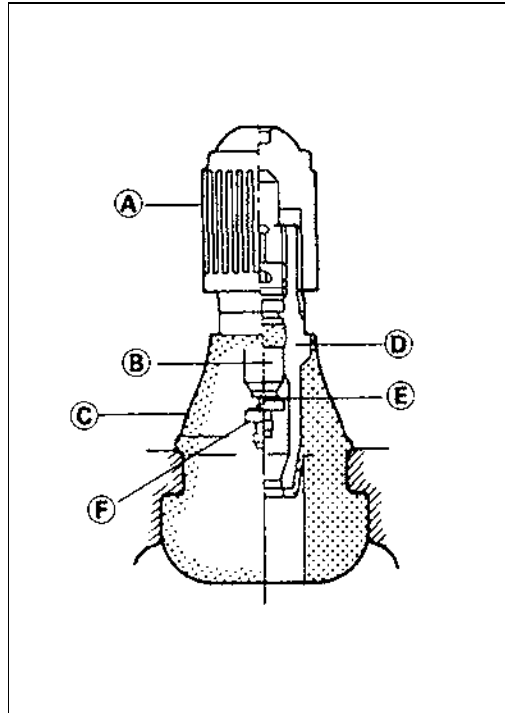

- Install a new air valve in the new rim.
- Remove the valve cap, lubricate the stem with a soap and water solution, and pull the stem [A] through the rim from the inside out until it snaps into place.

CAUTION

Do not use engine oil or petroleum distillates to lubricate the stem because they will deteriorate the rubber.

- Mount the tire on the new rim (see Tire Installation).
- Install the wheel (see Wheel Installation).
- Install the air valve cap.

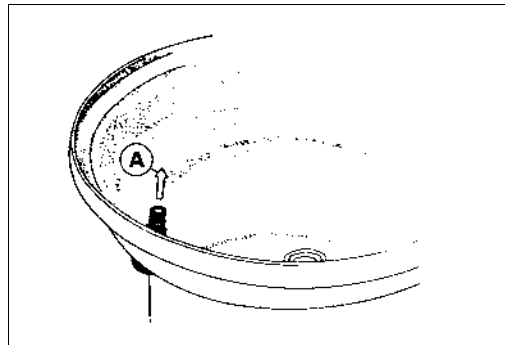

Tires

Tire Removal

- Remove the wheel.
- Unscrew the valve core to deflate the tire.
- Use a proper valve core tool [A].

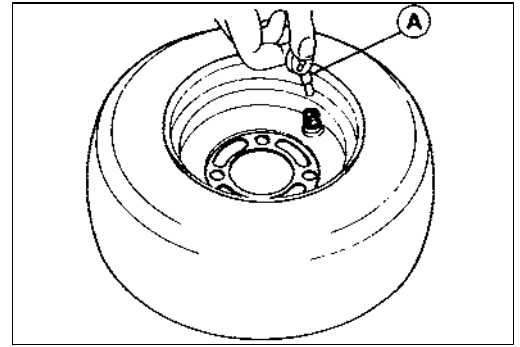

- Lubricate the tire beads and rim flanges on both sides of the wheel with a soap and water solution, or water [A]. This helps the tire beads slip off the rim flanges.

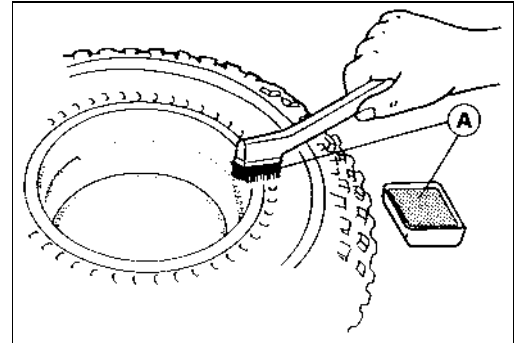

CAUTION
Do not lubricate the tire beads and rim flanges with engine oil or petroleum distillates because they will deteriorate the tire.

- Remove the tire from the rim using a suitable commercially available tire changer.

NOTE

- *The tires cannot be removed with hand tools because they fit the rims tightly.*

Tire Installation

- Inspect the rim (see Wheel (Rim) Inspection).
- Replace the air valve with a new one.

CAUTION
Replace the air valve with whenever the tire is replaced. Do not reuse the air valve.

- Check the tire for wear and damage (see Tire Inspection in Periodic Maintenance chapter).
- Lubricate the tire beads and rim flanges with a soap and water solution, or water.

⚠ WARNING
Do not use the lubricant other than a water and soap solution, or water to lubricate the tire beads and rim because it may cause tire separation.

- Check the tire rotation mark [A] on the tire, and install the tire on the rim accordingly.
- The tires should be installed on the rims so that each air valve is toward the outside of the vehicle.

NOTE

- *The direction of the tire rotation [B] is shown by an arrow on the tire sidewall.*

- Install the tire on the rim using a suitable commercially available tire changer.
- Lubricate the tire beads again and center the tire on the rim.

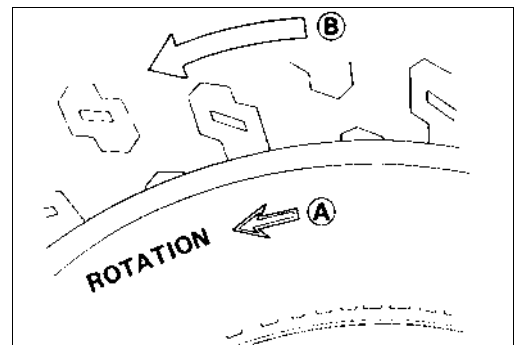

10-10 WHEELS / TIRES

Tires

- Support the wheel rim [A] on a suitable stand [B] to prevent the tire from slipping off.
- Inflate the tire until the tire beads seat on the rim.

Maximum Tire Air Pressure (to seat beads when cold)

Front and Rear: 250 kPa (2.5 kg/cm², 36 psi)

⚠ WARNING

Do not inflate the tire to more than the maximum tire air pressure. Overinflation can explode the tire with possibility of injury and loss of life.

- Check to see that rim lines [A] on both sides of the tire are parallel with the rim flanges [B].
- ★ If the rim lines and the rim flanges are not parallel, deflate the tire, lubricate the sealing surfaces again, and reinflate the tire.
- After the beads are properly seated, check for air leaks.
- Apply a soap and water solution around the tire bead and check for bubbles.
- Deflate the tire to the specified pressure.
- Check the tire pressure using an air pressure gauge.

NOTE

- *Kawasaki provides the air pressure gauge (P/N 52005-1082) with the owner's tool kit.*

Tire Air Pressure (when cold)

Front: 35 kPa (0.35 kg/cm², 5.0 psi)

Rear: 35 kPa (0.35 kg/cm², 5.0 psi)

- Install the air valve cap.
- Install the wheel (see Wheel Installation).
- Wipe off the soap and water solution on the tire and dry the tire before operation.

⚠ WARNING

Do not operate the vehicle with the water and soap still around the tire beads. They will cause tire separation, and a hazardous condition may result.

Tire Inspection

- Refer to Tire Inspection in Periodic Maintenance chapter.

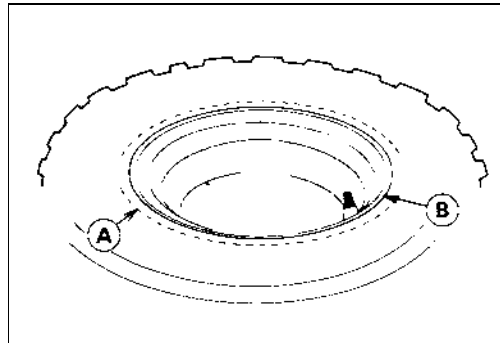
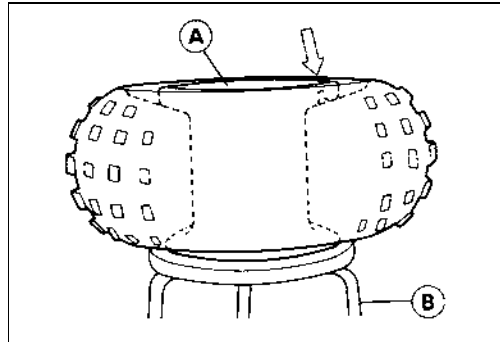

Front Hub

Front Hub Removal

- Remove:
 - Cap [A]
 - Cotter Pin [B]
- Loosen the axle nut [C].

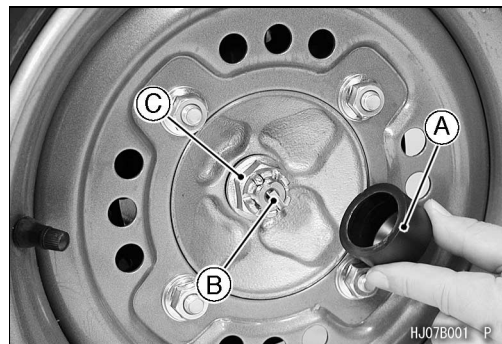

- Remove the wheel (see Wheel Removal).
- Remove the caliper [A] by taking off the mounting bolts, and let the caliper hang free.
- Remove the axle nut [B] and pull off the front hub [C] and brake disc.
- Separate the brake disc from the front hub.

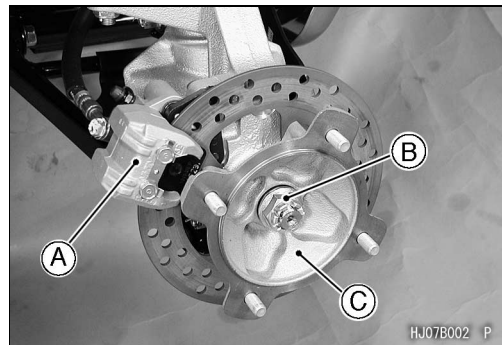

Front Hub Installation

- Install the brake disc (see Brakes chapter).
- Tighten:
 - Torque - Front Axle Nuts: 196 N·m (20 kgf·m, 145 ft·lb)
- Insert a new cotter pin [A] and bend it over the nut [B].

NOTE

- When inserting the cotter pin, if the slots in the nut do not align with the cotter pin hole in the axle shaft, tighten the nut clockwise up to next alignment.
- It should be within 30 degree.
- Loosen once and tighten again when the slit goes past the nearest hole.

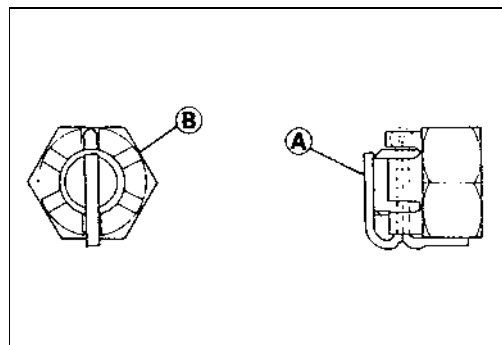

Front Hub Disassembly/Assembly

- Do not press the hub bolts [A] out.
- ★ If any hub bolt is damaged, replace the hub [B] and bolts as a unit.

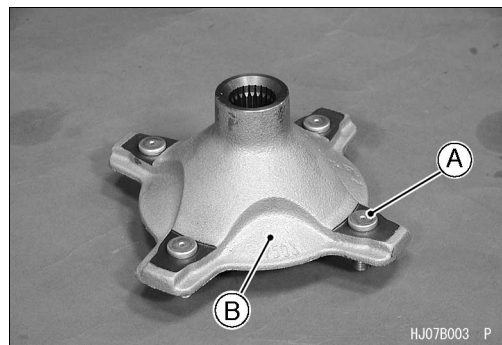

10-12 WHEELS / TIRES

Rear Hub

Rear Hub Removal

- Remove:
 - Cap [A]
 - Cotter Pin [B]
- Loosen the axle nut [C].

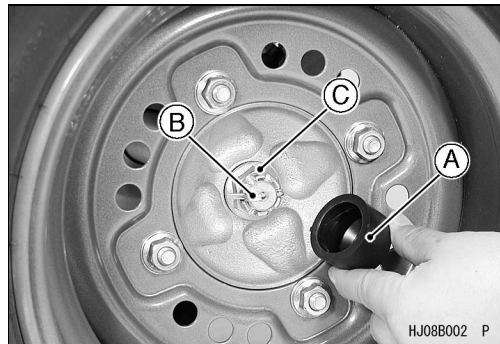

- Remove:
 - Wheel (see Wheel Removal)
 - Axle Nut [A]
 - Rear Hub [B]

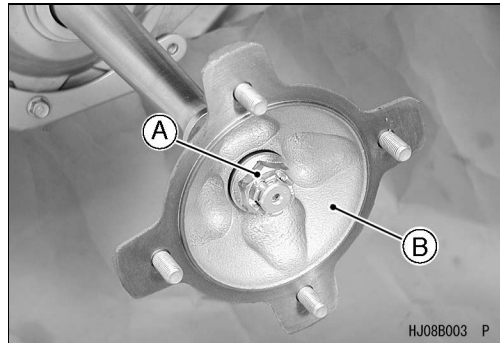

Rear Hub Installation

- Tighten:
 - Torque - Rear Axle Nuts: 265 N·m (27 kgf·m, 195 ft·lb)**
- Insert a new cotter pin [A] and bend it over the nut [B].

NOTE

- When inserting the cotter pin, if the slots in the nut do not align with the cotter pin hole in the axle shaft, tighten the nut clockwise up to next alignment.
- It should be within 30 degree.
- Loosen once and tighten again when the slit goes past the nearest hole.

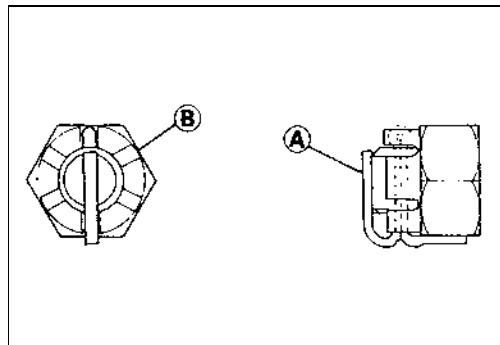

Rear Hub Disassembly/Assembly

- Do not press the hub bolts [A] out.
- ★ If any hub bolt is damaged, replace the hub [B] and bolts as a unit.

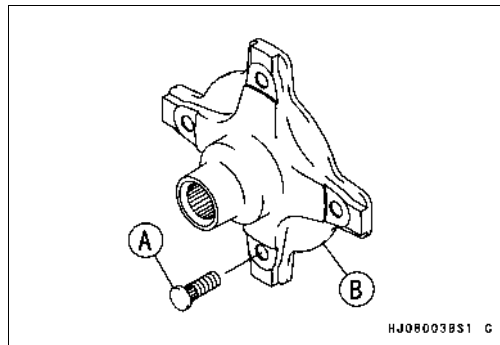

Final Drive

Table of Contents

Exploded View.....	11-2	Front Final Gear Case Disassembly.....	11-29
Specifications.....	11-8	Front Final Gear Case Assembly.....	11-31
Output Bevel Gears.....	11-9	Oil Seal Installation.....	11-35
Output Drive Bevel Gear Removal.....	11-9	Ring Gear Disassembly.....	11-35
Output Drive Bevel Gear Installation.....	11-9	Ring Gear Assembly.....	11-36
Output Drive Bevel Gear Disassembly.....	11-10	LSD Clutch Torque Inspection.....	11-36
Output Drive Bevel Gear Assembly.....	11-12	Pinion Gear Unit Disassembly.....	11-37
Output Driven Bevel Gear Removal.....	11-12	Pinion Gear Unit Assembly.....	11-37
Output Driven Bevel Gear Installation.....	11-13	Front Final Bevel Gear Adjustment.....	11-37
Output Driven Bevel Gear Disassembly.....	11-13	Bevel Gear Inspection.....	11-41
Output Driven Bevel Gear Assembly.....	11-14	Differential Gear Inspection.....	11-41
Output Bevel Gears Adjustment.....	11-16	Rear Propeller Shaft.....	11-43
Bevel Gears Inspection.....	11-19	Rear Propeller Shaft Removal.....	11-43
Cam Damper Inspection.....	11-19	Rear Propeller Shaft Installation.....	11-43
Front Propeller Shaft.....	11-20	Rear Propeller Shaft Joint Boot Inspection.....	11-43
Front Propeller Shaft Removal.....	11-20	Rear Propeller Shaft Inspection.....	11-43
Front Propeller Shaft Installation.....	11-20	Rear Axle.....	11-44
Front Axle.....	11-21	Rear Axle Removal.....	11-44
Front Axle Removal.....	11-21	Rear Axle Installation.....	11-44
Front Axle Installation.....	11-21	Ball Bearing Wear.....	11-44
Front Axle Joint Boot Inspection.....	11-21	Rear Axle Runout Inspection.....	11-44
Front Axle Joint Boot Replacement.....	11-22	Rear Final Gear Case.....	11-45
Front Final Gear Case.....	11-27	Rear Final Gear Case Oil Level Inspection.....	11-45
Front Final Gear Case Oil Level Inspection.....	11-27	Rear Final Gear Case Oil Change.....	11-45
Front Final Gear Case Oil Change.....	11-27	Rear Final Gear Case Removal.....	11-45
Variable Differential Control Lever Position Inspection.....	11-27	Rear Final Gear Case Installation.....	11-45
Variable Differential Control Lever Position Adjustment.....	11-27	Rear Final Gear Case Disassembly.....	11-46
Variable Differential Control Lever Removal.....	11-27	Rear Final Gear Case Assembly.....	11-47
Variable Differential Control Lever Installation.....	11-27	Oil Seal Installation.....	11-48
Variable Differential Control Cable Installation.....	11-28	Rear Final Bevel Gear Adjustment.....	11-49
Variable Differential Control Cable Lubrication.....	11-28	Pinion Gear Unit Disassembly.....	11-51
Variable Differential Control Cable Inspection.....	11-28	Pinion Gear Unit Assembly.....	11-51
Front Final Gear Case Removal.....	11-28	Bevel Gear Inspection.....	11-52
Front Final Gear Case Installation.....	11-29	Bearing and Oil Seal.....	11-53
		Ball or Needle Bearing Inspection.....	11-53
		Oil Seal Inspection.....	11-54

11-2 FINAL DRIVE

Exploded View

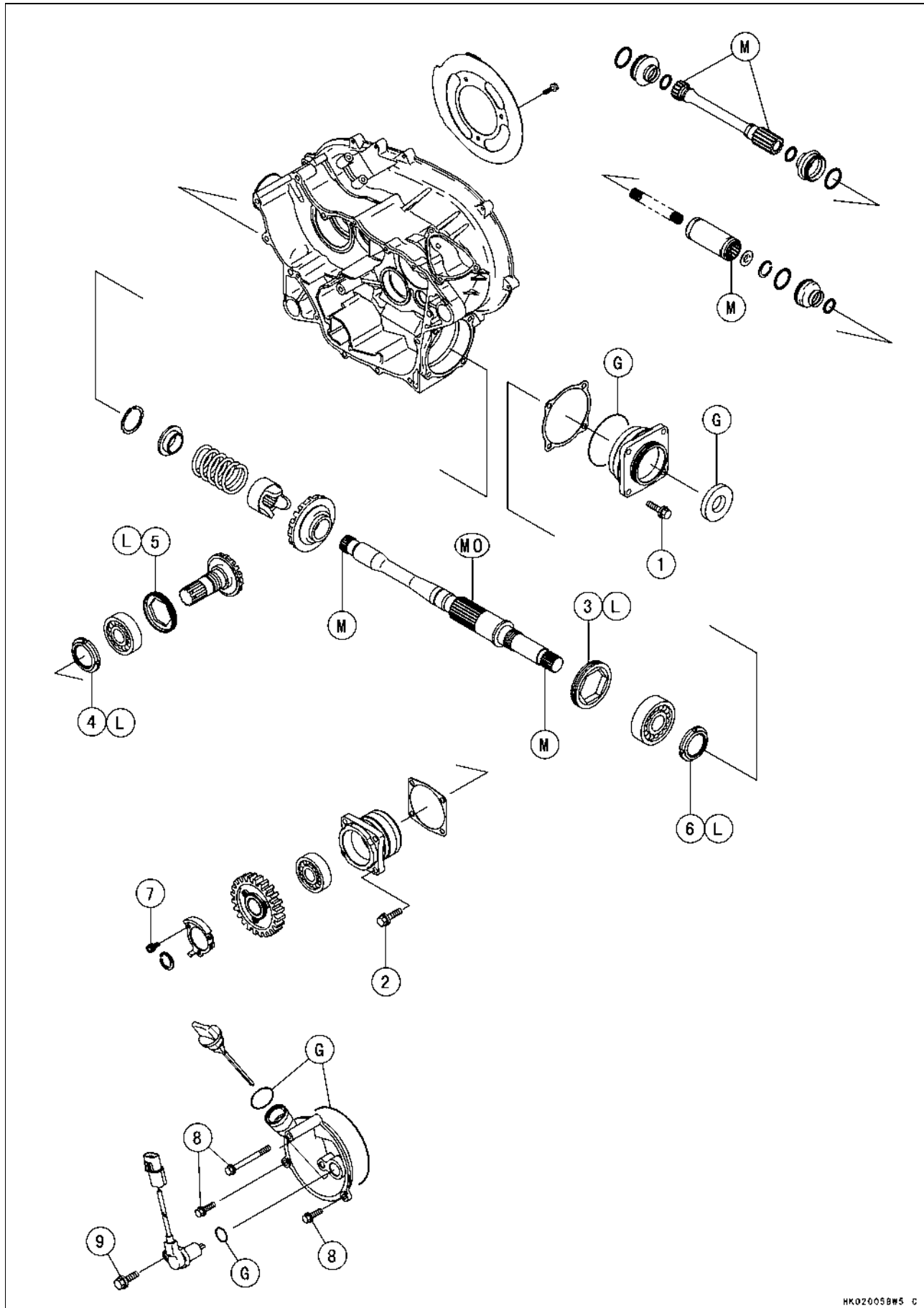

Exploded View

No.	Fastener	Torque			Remarks
		N·m	kgf·m	ft·lb	
1	Output Driven Bevel Gear Housing Bolts	26	2.7	20	
2	Output Drive Bevel Gear Housing Bolts	26	2.7	20	
3	Bearing Holder	137	14	101	L
4	Bevel Gear Holder Nut	157	16	116	L
5	Bearing Holder	118	12	87	L
6	Output Shaft Holder Nut	157	16	116	L
7	Rotor Mounting Bolts	12	1.2	104 in·lb	
8	Output Drive Bevel Gear Cover Bolts	8.8	0.9	78 in·lb	
9	Forward/Reverse Detecting Sensor Mounting Bolts	15	1.5	11	

G: Apply grease for oil seal and O-ring.

L: Apply a non-permanent locking agent.

M: Apply molybdenum disulfide grease.

MO: Apply molybdenum disulfide oil.

11-4 FINAL DRIVE

Exploded View

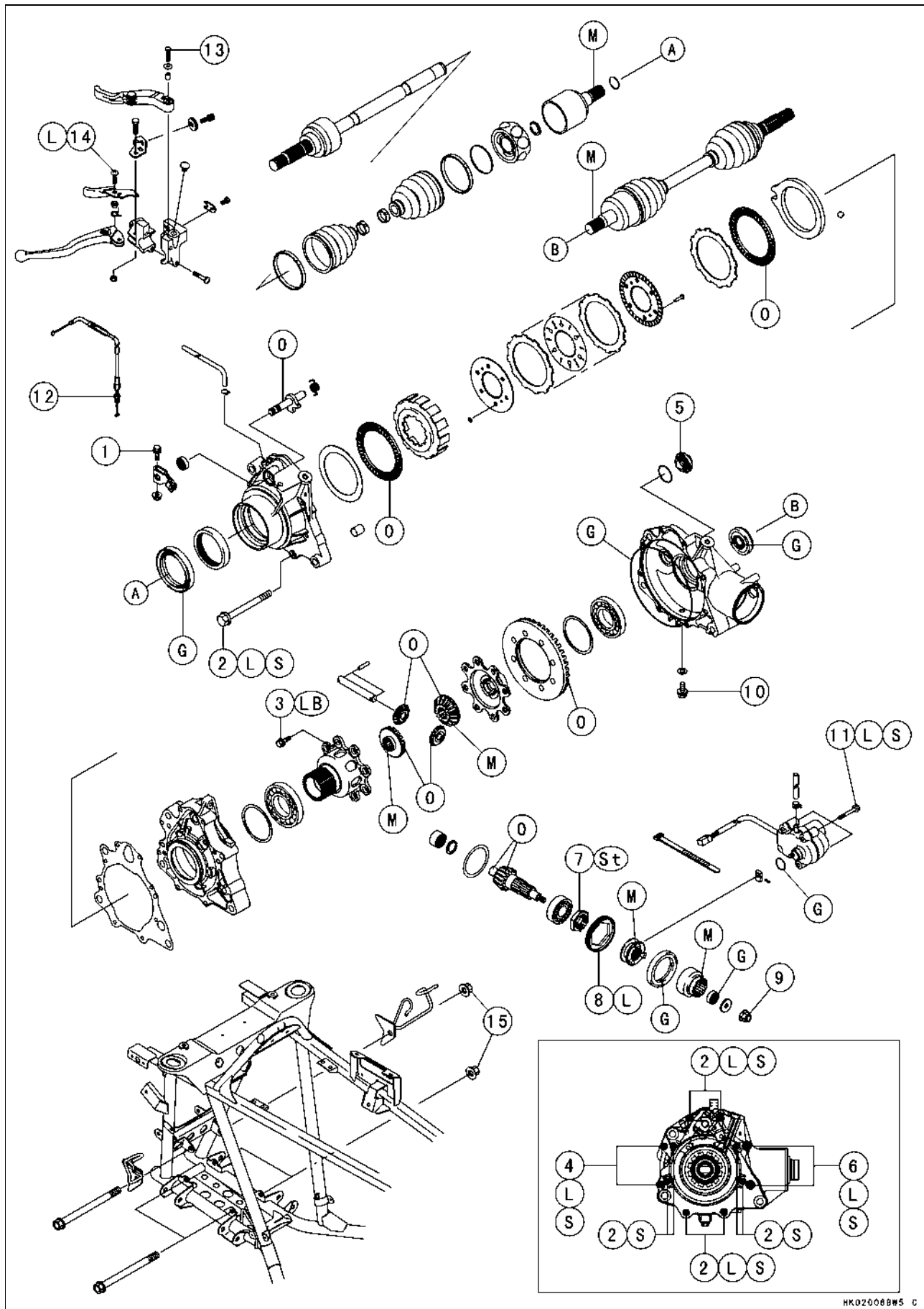

Exploded View

No.	Fastener	Torque			Remarks
		N·m	kgf·m	ft·lb	
1	Variable Front Differential Control Shift Shaft Lever Bolt	8.8	0.9	78 in·lb	
2	Front Final Gear Case Left Cover Bolts (M6)	9.8	1.0	87 in·lb	S, L(4)
3	Ring Gear Bolts	57	5.8	42	LB
4	Front Final Gear Case Center Cover Bolts (M6)	9.8	1.0	87 in·lb	L, S
5	Oil Filler Cap	29	3.0	22	
6	Front Final Gear Case Center Cover Bolts (M8)	24	2.4	17	L, S
7	Pinion Gear Bearing Holder Nut	127	13	94	St
8	Pinion Gear Bearing Holder	137	14	101	L
9	Front Final Gear Case Coupling Nut	20	2.0	14	
10	Oil Drain Plug	24	2.4	17	
11	2WD/4WD Actuator Mounting Bolts	9.8	1.0	87 in·lb	L, S
12	Variable Differential Control Cable Locknut	17	1.7	12	
13	Variable Differential Control Lever Bolt	3.5	0.36	31 in·lb	
14	Parking Brake Lever Screw	2.2	0.22	19 in·lb	L
15	Front Final Gear Case Bolts and Nuts	42	4.3	31	

- G: Apply grease for oil seal and O-ring.
- L: Apply a non-permanent locking agent.
- M: Apply molybdenum disulfide grease.
- O: Apply engine oil.
- LB: Apply a non-permanent locking agent (Three Bond TB2471 Blue).
- S: Follow the specific tightening sequence.
- St: Stake the fasteners to prevent loosening.

11-6 FINAL DRIVE

Exploded View

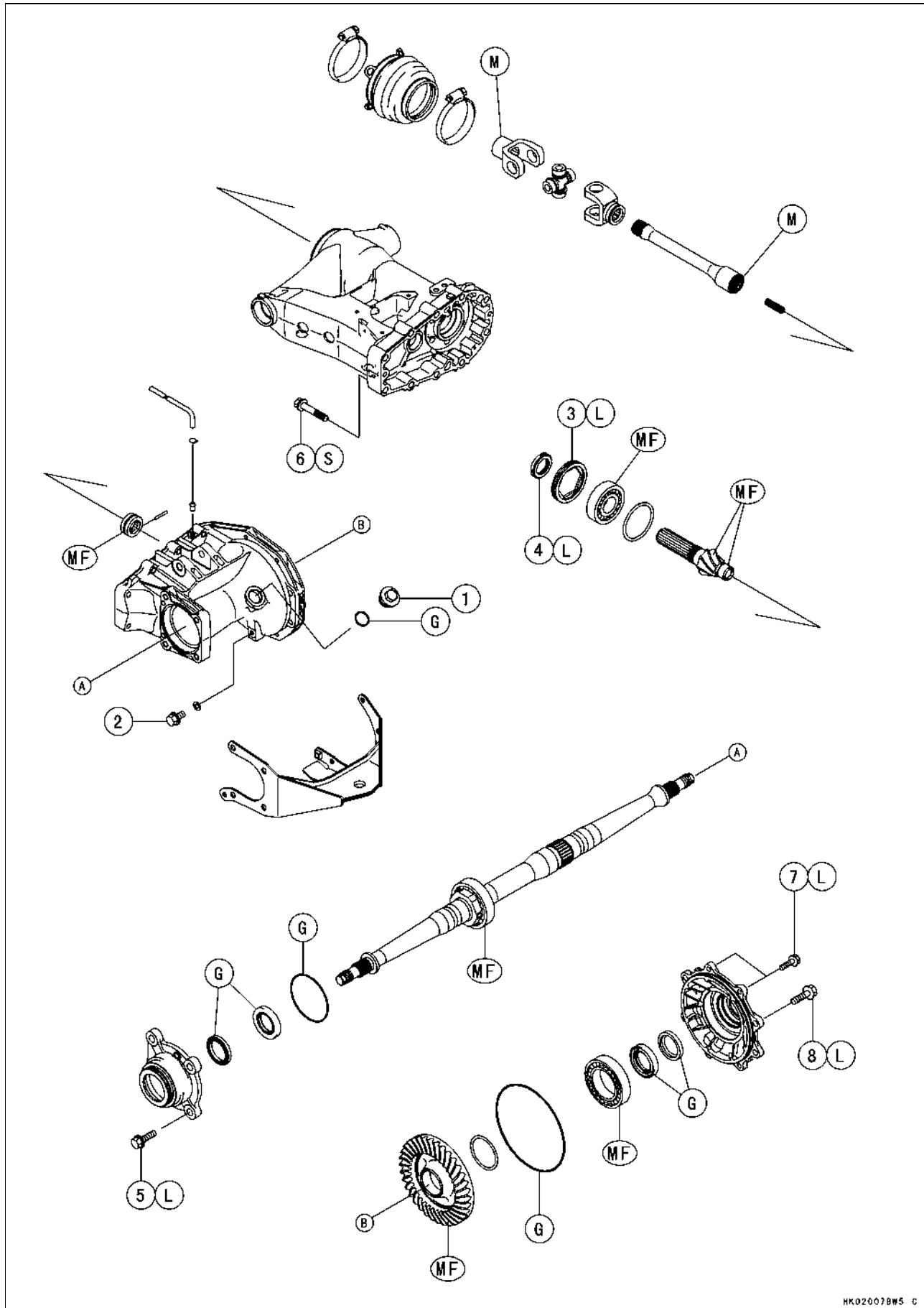

Exploded View

No.	Fastener	Torque			Remarks
		N·m	kgf·m	ft·lb	
1	Oil Filler Cap	29	3.0	22	
2	Oil Drain Plug	20	2.0	14	
3	Pinion Gear Bearing Holder	137	14	101	L
4	Pinion Gear Bearing Holder Nut	157	16	116	L
5	Trailer Hitch Btacket Bolts (M10)	49	5.0	36	L
6	Rear Final Gear Case Bolts	42	4.3	31	S
7	Rear Final Gear Case Right Cover Bolts (M8)	24	2.4	17	L
8	Rear Final Gear Case Right Cover Bolts (M10)	49	5.0	36	L

- G: Apply grease for oil seal and O-ring.
- L: Apply a non-permanent locking agent.
- M: Apply molybdenum disulfide grease.
- MF: Apply MOBIL FLUID 424 or equivalent oil.
- S: Follow the specific tightening sequence.

11-8 FINAL DRIVE

Specifications

Item	Standard	Service Limit
Output Bevel Gear Case Output bevel gear backlash	0.06 ~ 0.12 mm (0.0024 ~ 0.0047 in.) (at output drive shaft spline)	---
Front Final Gear Case: Gear case oil (same engine oil): Type Viscosity Oil level Capacity LSD clutch torque: (when variable differential control lever is released.) (when variable differential control lever is pulled in.) Bevel gear backlash	API SF or SG API SH or SJ with JASO MA SAE10W-40 Filler opening bottom 430 mL (0.45 US qt) 15 ~ 20 N·m (1.5 ~ 2.0 kg·m, 11 ~ 14 ft·lb) 157 N·m (16 kg·m, 116 ft·lb) or more 0.10 ~ 0.20 mm (0.004 ~ 0.008 in.) (at pinion gear spline)	--- --- --- --- --- --- ---
Rear Axle Shaft Rear axle shaft runout	TIR 1 mm (0.04 in.) or less	TIR 2 mm (0.08 in.)
Rear Final Gear Case: Gear case oil: Type Oil level Capacity Rear final bevel gear backlash	MOBIL Fluid 424 or Kawa Chem Gear & Wet Brake Oil (CITGO TRANSGARD TRACTOR HYDRAULIC FLUID) Filler opening bottom 900 mL (0.95 US qt) 0.07 ~ 0.14 mm (0.003 ~ 0.006 in.) (at pinion gear spline)	--- --- --- ---

- Special Tools - Bearing Puller: 57001-135**
Inside Circlip Pliers: 57001-143
Outside Circlip Pliers: 57001-144
Circlip Pliers: 57001-154
Oil Seal & Bearing Remover: 57001-1058
Bearing Driver Set: 57001-1129
Socket Wrench: 57001-1363
Damper Spring Compressor Set: 57001-1475
Holder & Guide Arbor: 57001-1476
Socket Wrench, Hex 50: 57001-1478
Output Shaft Holder & Spacer: 57001-1479
Pinion Gear Holder: 57001-1480
Nut Holding Bolts: 57001-1481
Socket Wrench: 57001-1482
Socket Wrench, Hex 41: 57001-1484
Pinion Gear Holder: 57001-1485
Oil Seal Driver: 57001-1487
Gear Holder & Socket Wrench, Hex 24: 57001-1489
Hexagon Wrench, Hex 41: 57001-1491
Oil Seal Driver, ϕ 18: 57001-1505
Oil Seal Driver, ϕ 48: 57001-1506

Output Drive Bevel Gears

Output Drive Bevel Gear Removal

- Remove:
 - Left Side Cover (see Frame chapter)
 - Forward/Reverse Detecting Sensor Lead Connector [A]
 - Output Drive Bevel Gear Cover Bolts [B]
 - Output Drive Bevel Gear Cover [C]

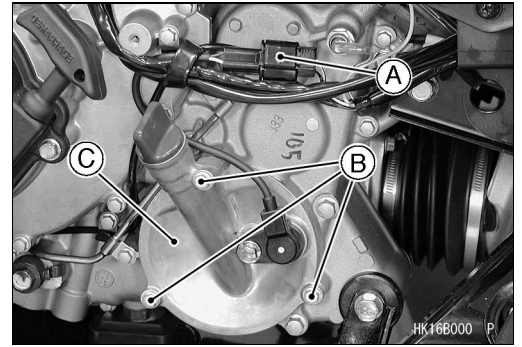

- Remove:
 - Circlip [A]
- Special Tool - Outside Circlip Pliers: 57001-144**
- Remove:
 - Output Drive Idle Gear [B]

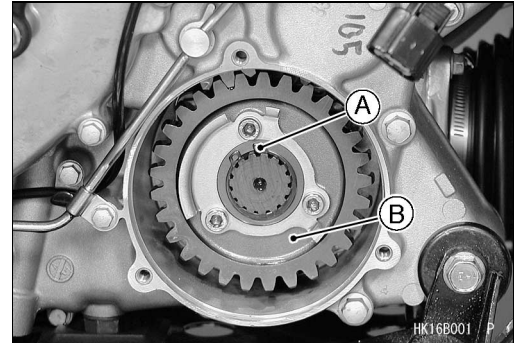

- Remove:
 - Output Drive Bevel Gear Housing Bolts [A]
 - Output Drive Bevel Gear Housing [B]

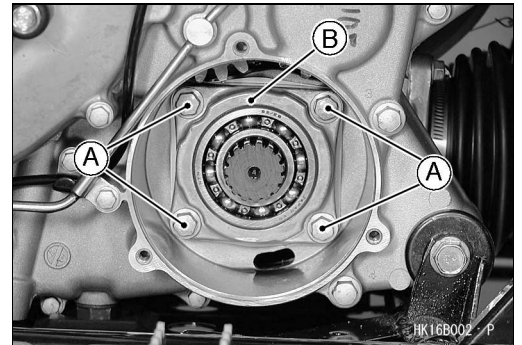

Output Drive Bevel Gear Installation

- Install the output drive bevel gear housing.
- Tighten:
 - Torque - Output Drive Bevel Gear Housing Bolts: 26 N·m (2.7 kgf·m, 20 ft·lb)**
- Install the rotor [A] so that the projections [B] face outward.
- Tighten:
 - Torque - Rotor Mounting Bolts [C]: 12 N·m (1.2 kgf·m, 104 in·lb)**
- Install:
 - Output Drive Idle Gear
 - New Circlip
- Special Tool - Outside Circlip Pliers: 57001-144**

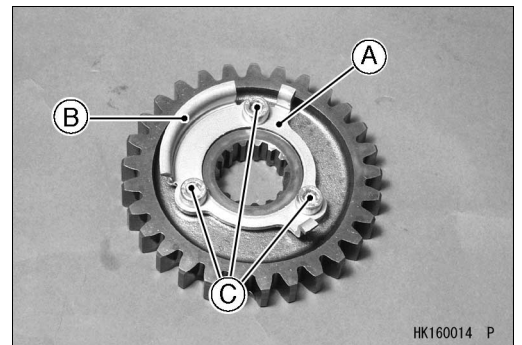

11-10 FINAL DRIVE

Output Bevel Gears

- Apply grease:
 - O-rings [A]
- Install:
 - Output Drive Bevel Gear Cover [B]
- Tighten:
 - Torque - Output Drive Bevel Gear Cover Bolts [C]: 8.8 N·m (0.9 kgf·m, 78 in·lb)**

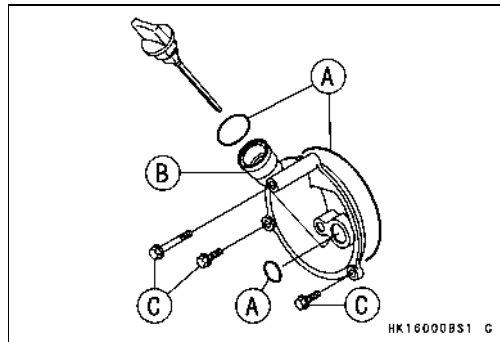

- Install:
 - Forward/Reverse Detecting Sensor [A]
- Tighten:
 - Torque - Forward/Reverse Detecting Sensor Mounting Bolt: 15 N·m (1.5 kgf·m, 11 ft·lb)**



Output Drive Bevel Gear Disassembly

- Remove:
 - Output Drive Bevel Gear Housing [A] (see Output Drive Bevel Gear Removal)
- Look through the hole [B] in the housing.
- Turn the bevel gear [C] until the groove of the output drive bevel gear holder nut is seen.

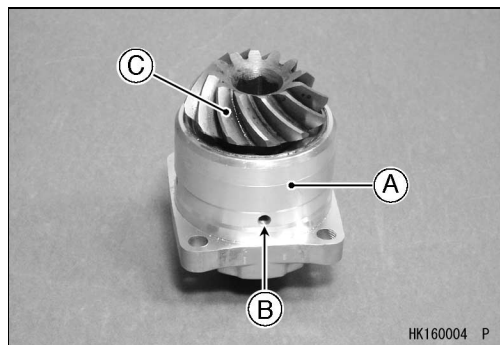

- Tighten the nut holding bolts [A] (4) securely into the grooves [B] of the bevel gear holder nut [C] in the output drive bevel gear housing.

Special Tool - Nut Holding Bolts: 57001-1481

- [D] Output Drive Bevel Gear Housing
- [E] Outer Ball Bearing
- [F] Inner Ball Bearing
- [G] Bearing Holder
- [H] Output Drive Bevel Gear

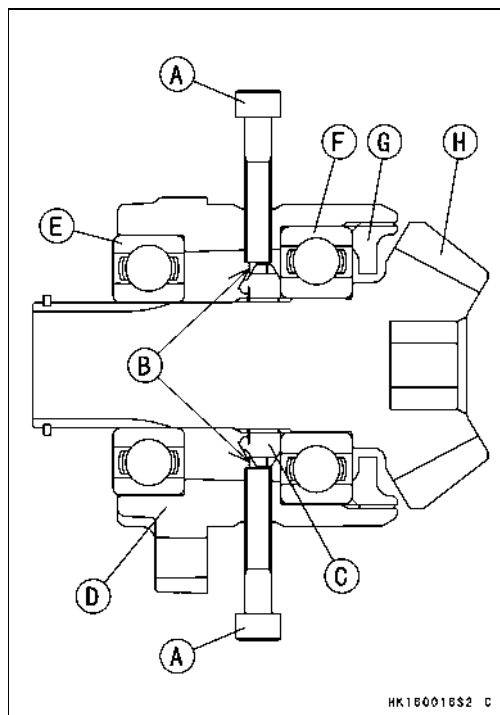

Output Bevel Gears

- Hold the output drive bevel gear housing [A] in a vise.
- Loosen the bevel gear [B] using an Allen wrench about four rotations.
- Remove one nut holding bolt, and look at through the hole.
- ★ If the groove of the bevel gear holder nut is not seen, loosen the other three bolts.

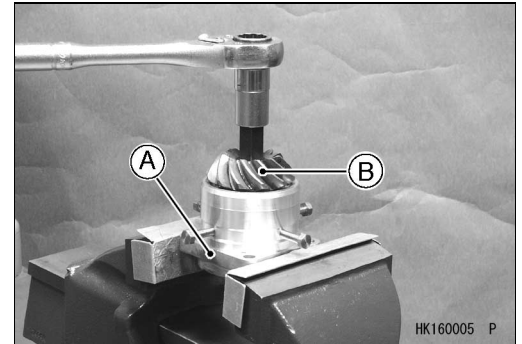

- Drive the gear shaft end using a copper mallet until the grooves of the bearing holder nut can be seen again.
- Retighten the nut holding bolts (4) securely into the groove of the bevel gear holder nut in the output drive bevel gear housing.

Special Tool - Nut Holding Bolts: 57001-1481

- Repeat the above procedure, and remove the bevel gear from the housing.

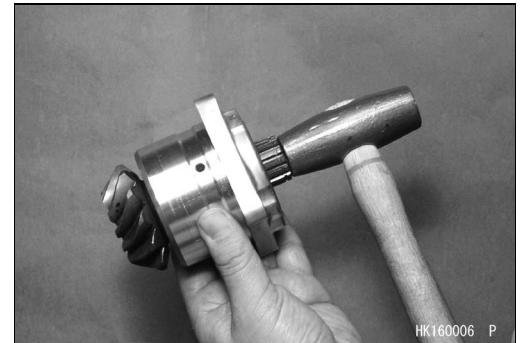

- Remove the bearing holder [A] using the hexagon wrench [B].

Special Tool - Hexagon Wrench, Hex 41: 57001-1491

- If the holder seems too difficult to break free, apply heat to softer the locking agent.

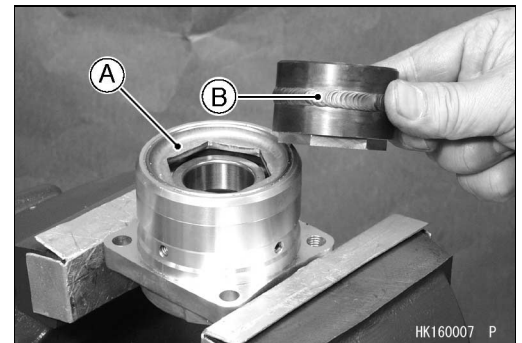

- Remove:
Outer Ball Bearing [A]

Special Tool - Oil Seal & Bearing Remover [B]: 57001-1058

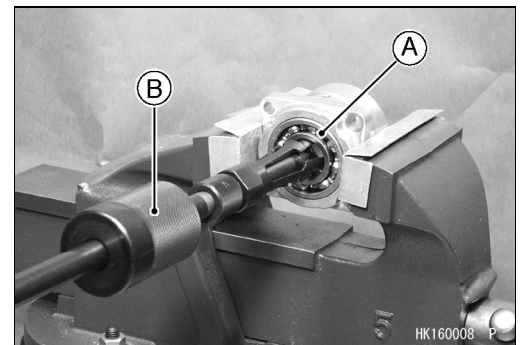

- Remove:
Output Drive Bevel Gear Holder Nut
Inner Ball Bearing [A]

Special Tool - Oil Seal & Bearing Remover [B]: 57001-1058

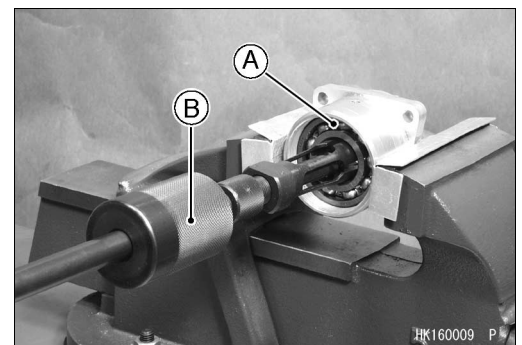

11-12 FINAL DRIVE

Output Bevel Gears

Output Drive Bevel Gear Assembly

- Press the new inner ball bearing until it is bottomed.

Special Tool - Bearing Driver Set [A]: 57001-1129

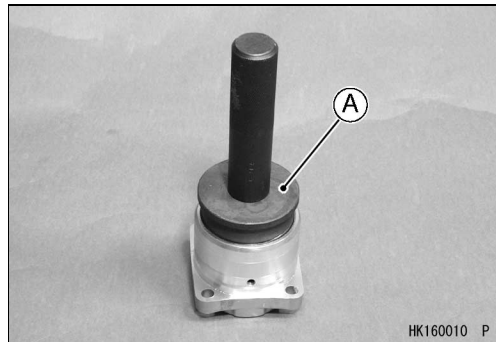

- Apply a non-permanent locking agent to the threads of the bearing holder [A] and tighten it so that the deep side [B] faces outward.

Torque - Bearing Holder: 118 N·m (12 kgf·m, 87 ft·lb)

- Press the output drive bevel gear until it is bottomed.

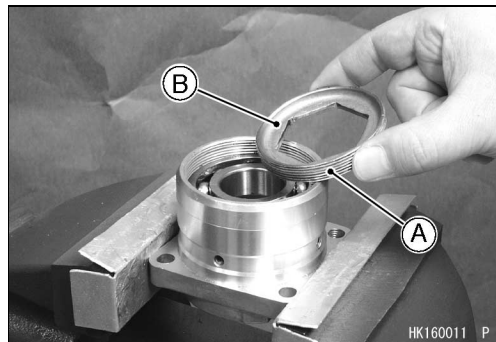

- Apply a non-permanent locking agent to the threads of the bevel gear holder nut [A] and tighten it so that the projection side [B] faces outward.

Special Tool - Socket Wrench: 57001-1482 [C]

Torque - Bevel Gear Holder Nut: 157 N·m (16 kgf·m, 116 ft·lb)

- Press the new outer ball bearing until it is bottomed.

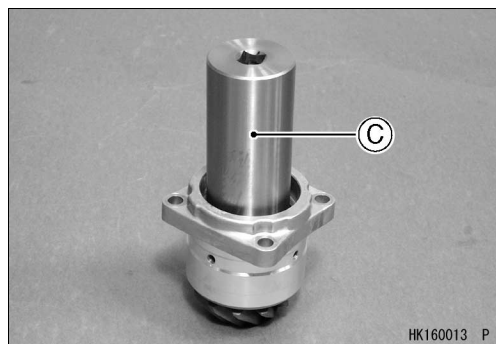
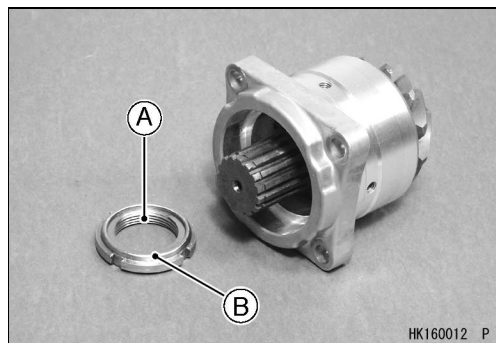

Output Driven Bevel Gear Removal

- Remove:

Swingarm (see Suspension chapter) and Front Propeller Shaft (see Front Propeller Shaft Removal) or Engine (see Engine Removal/ Installation chapter)

Output Driven Bevel Gear Housing Bolts [A]

Output Driven Bevel Gear Housing [B]

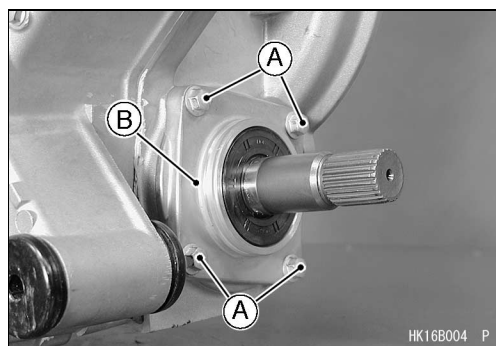

Output Bevel Gears

- Tap lightly the front end [A] of the output driven bevel gear shaft using a plastic mallet.
- The output driven bevel gear shaft assembly comes off with the housing.

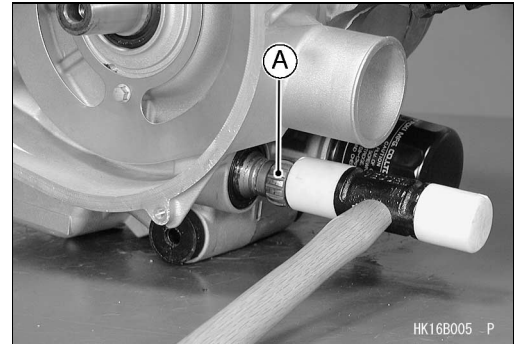

Output Driven Bevel Gear Installation

- Apply grease:
 - O-ring [A]
- Install the output driven bevel gear shaft assembly.
- Tighten:
 - Torque - Output Driven Bevel Gear Housing Bolts: 26 N·m (2.7 kgf·m, 20 ft·lb)

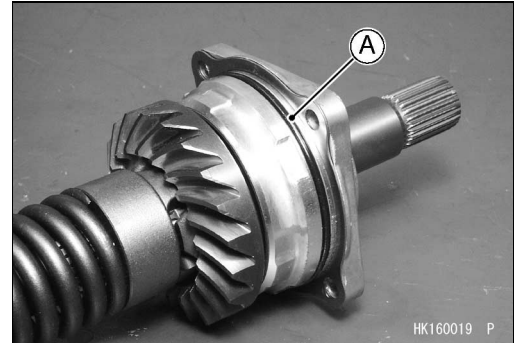

Output Driven Bevel Gear Disassembly

- Remove:
 - Output Driven Bevel Gear Housing Assembly (see Output Driven Bevel Gear Removal)
- Hold the holder in a vise, and set the housing assembly [A] on the holder.
- Special Tools - Damper Spring Compressor Set [B]: 57001-1475
Holder & Guide Arbor [C]: 57001-1476
- Tighten the nuts [D] and compress the damper spring [E].

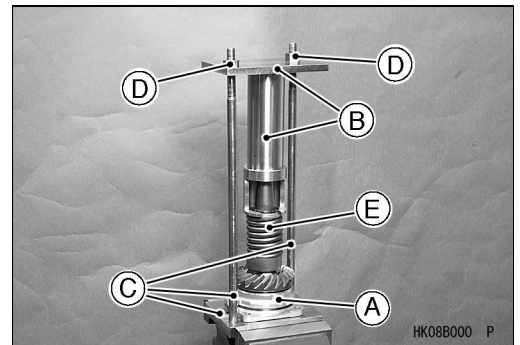

- Remove:
 - Circlip [A]
- Special Tool - Circlip Pliers: 57001-154

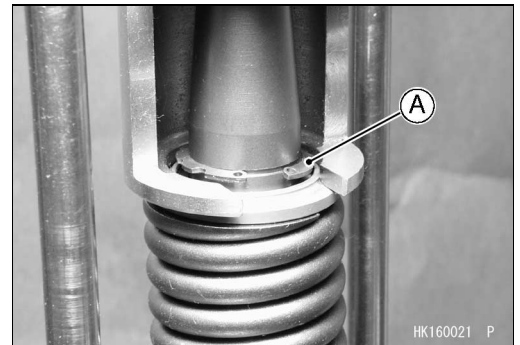

- Remove:
 - Circlip [A]
 - Spring Holder [B]
 - Spring [C]
 - Cam Damper [D]
 - Output Driven Bevel Gear [E]

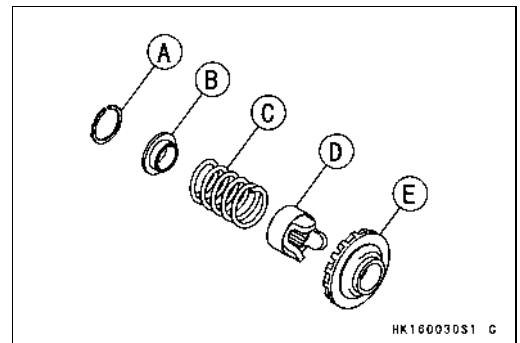

11-14 FINAL DRIVE

Output Bevel Gears

- Hold the housing assembly [A] with the output shaft holder [B] & spacer [C] in a vise.

Special Tool - Output Shaft Holder & Spacer: 57001-1479

- Remove:
Oil Seal [D]

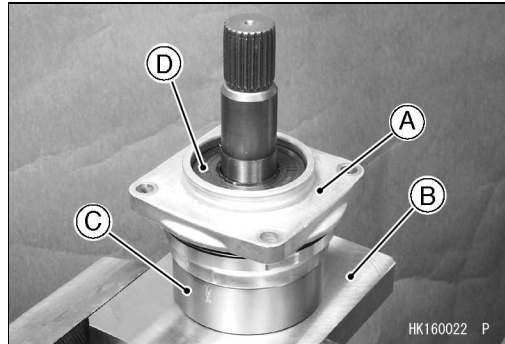

- Remove:
Output Shaft Holder Nut [A]

Special Tool - Socket Wrench [B]: 57001-1482

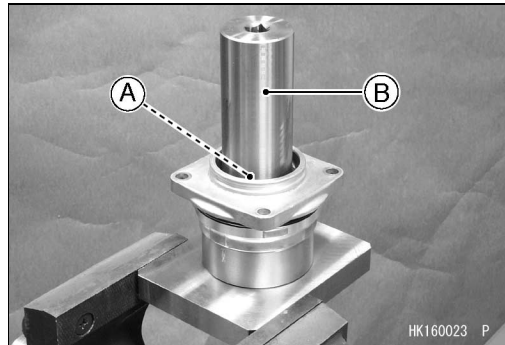

- Hold the housing assembly [A] with the holder [B] in a vise.

Special Tool - Holder & Guide Arbor : 57001-1476

- Remove:
Bearing Holder [C]

Special Tool - Socket Wrench [D], Hex 50: 57001-1478

- If the holder seems too difficult to break free, apply heat to soften the locking agent.

- Remove:
Ball Bearing

Special Tool - Oil Seal & Bearing Remover: 57001-1058

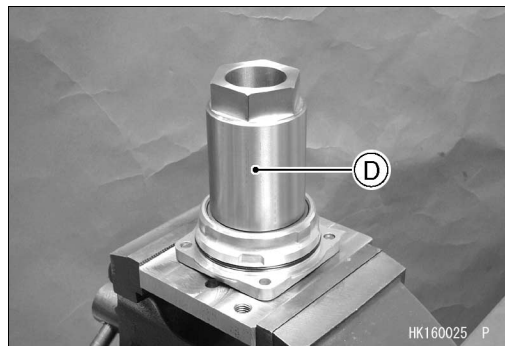
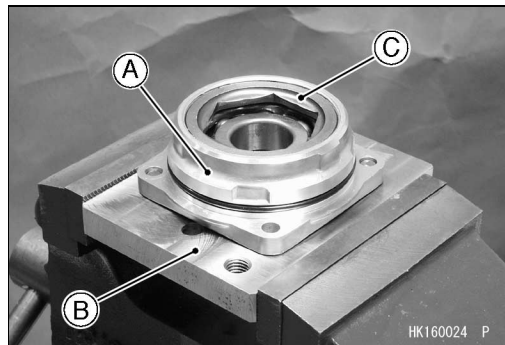

Output Driven Bevel Gear Assembly

- Press the new ball bearing until it is bottomed.

Special Tool - Bearing Driver Set [A]: 57001-1129

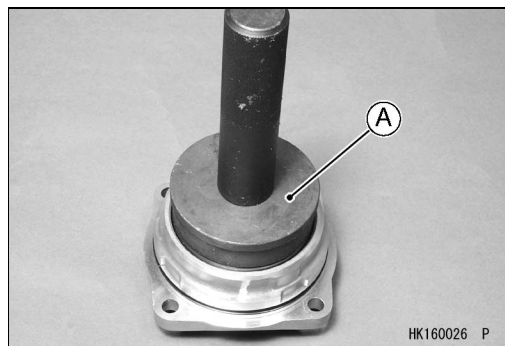

Output Bevel Gears

- Hold the housing assembly [A] with the holder [B] in a vise.
 - Special Tool - Holder & Guide Arbor: 57001-1476**
- Apply a non-permanent locking agent to the threads of the bearing holder [C] and tighten it.
 - Special Tool - Socket Wrench, Hex 50: 57001-1478**
 - Torque - Bearing Holder: 137 N·m (14 kgf·m, 101 ft·lb)**

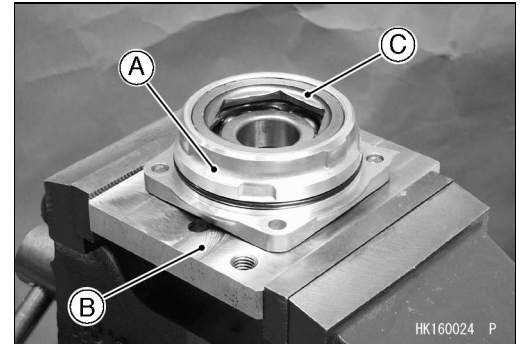

- Hold the housing assembly [A] with the output shaft holder [B] & spacer [C] in a vise.
 - Special Tool - Output Shaft Holder & Spacer: 57001-1479**
- Insert the output shaft [D] in the housing.
- Apply a non-permanent locking agent to the threads of the output shaft holder nut [E] and tighten it so that the projection side [F] faces outward.
 - Special Tool - Socket Wrench: 57001-1482**
 - Torque - Output Shaft Holder Nut: 157 N·m (16 kgf·m, 116 ft·lb)**
- Apply grease to the oil seal and press it.

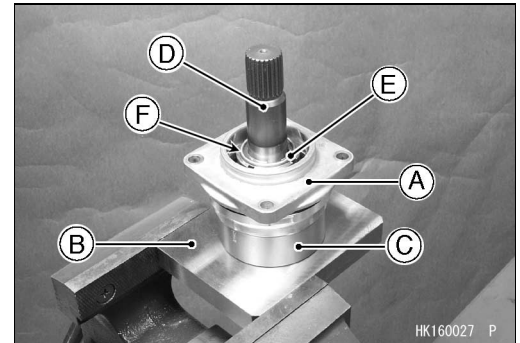

- Hold the holder [A] in a vise, and set the housing assembly [B] on the holder.
 - Special Tool - Holder & Guide Arbor: 57001-1476**
- Install:
 - Output Driven Bevel Gear [C]
 - Cam Damper [D]
 - Spring [E]
 - Spring Holder [F]
 - Circlip [G]

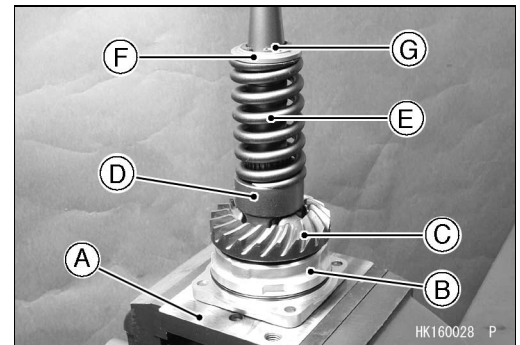

- Install:
 - Guide Bars [A]
 - Damper Spring Compressor Set [B]
 - Special Tools - Holder & Guide Arbor: 57001-1476**
 - Damper Spring Compressor Set: 57001-1475**
- Tighten the nuts [C] and compress the damper spring.
- Install:
 - Circlip
 - Special Tool - Circlip Pliers: 57001-154**

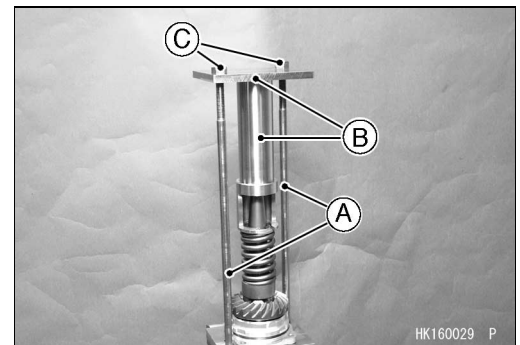

11-16 FINAL DRIVE

Output Bevel Gears

Output Bevel Gears Adjustment

The **backlash** and **tooth contact pattern** of the bevel gears must be correct to prevent the gears from making noise and being damaged.

When replacing any one of the backlash-related parts, be sure to check and adjust the backlash and tooth contact. First adjust the backlash, and then tooth contact by replacing shims.

These two adjustments are of critical importance and must be carried out in the correct sequence, using the procedures shown.

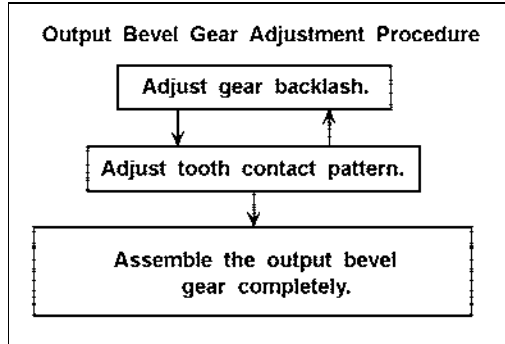

Output Bevel Gear (Backlash-related Parts)

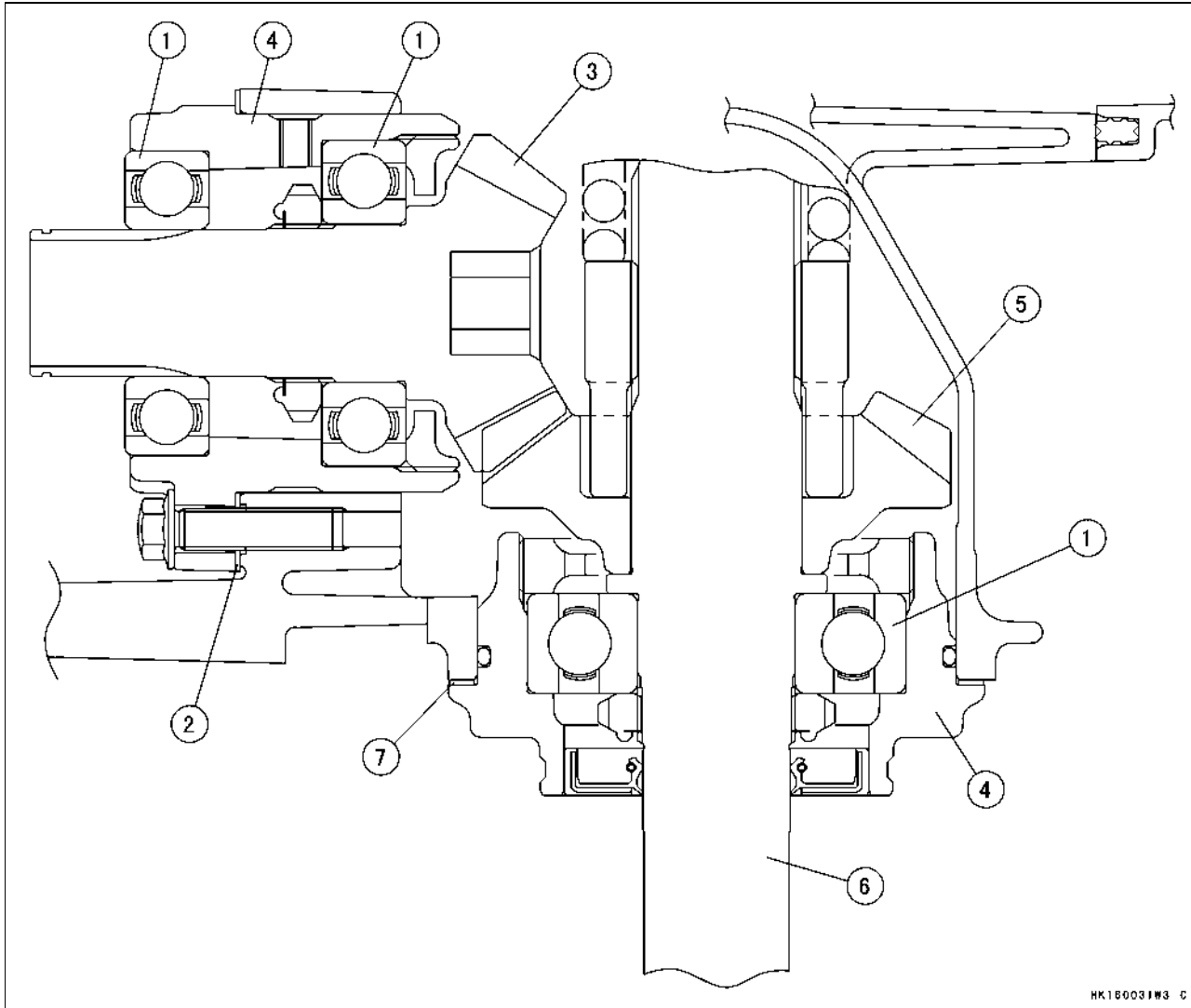

- 1. Ball Bearings
- 2. Drive Bevel Gear Shims
- 3. Output Drive Bevel Gear

- 4. Bearing Housings
- 5. Output Driven Bevel Gear
- 6. Output Driven Shaft

- 7. Driven Bevel Gear Shims

Output Bevel Gears

Drive Bevel Gear Shims for Tooth Contact Adjustment

Thickness	Part Number
0.15 mm (0.006 in.)	92180-1311
0.2 mm (0.008 in.)	92180-1312
0.5 mm (0.020 in.)	92180-1313
0.8 mm (0.031 in.)	92180-1314
1.0 mm (0.039 in.)	92180-1351
1.2 mm (0.047 in.)	92180-1352

Driven Bevel Gear Shims for Backlash Adjustment

Thickness	Part Number
0.15 mm (0.006 in.)	92180-1307
0.2 mm (0.008 in.)	92180-1308
0.5 mm (0.020 in.)	92180-1309
0.8 mm (0.031 in.)	92180-1310
1.0 mm (0.039 in.)	92180-1349
1.2 mm (0.047 in.)	92180-1350

Bevel Gear Backlash Adjustment

- The amount of backlash is influenced by driven bevel gear position more than by drive bevel gear position.
- Remove the output drive idle gear (see Output Drive Bevel Gear Removal).
- Set up a dial gauge [A] against the output drive shaft spline groove to check gear backlash.
- To measure the backlash, turn the shaft clockwise and counterclockwise slightly so as not to move the mate gear. A rod can be inserted through the lower hole of the housing and into contact with driven gear. This may help to hold it still. The difference between the highest and lowest gauge reading is the amount of backlash.
- ★ If the backlash is not within the limit, replace the shim(s) at the driven bevel gear.
- ★ Change the thickness a little at a time.
- Recheck the backlash, and readjust as necessary.

Output Bevel Gear Backlash

Standard: 0.06 ~ 0.12 mm (0.0024 ~ 0.0047 in.) (at output drive shaft spline)

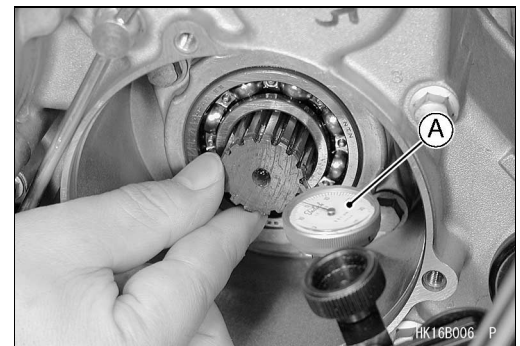

11-18 FINAL DRIVE

Output Bevel Gears

Tooth Contact Adjustment

- Tooth contact location is influenced by drive gear position more than by driven gear position.
- Clean any dirt and oil off the bevel gear teeth.
- Apply checking compound to 4 or 5 teeth on the output driven bevel gear.

NOTE

- Apply checking compound to the teeth in a thin, even coat with a fairly stiff paint brush. If painted too thickly, the exact tooth pattern may not appear.
- The checking compound must be smooth and firm with the consistency of tooth paste.
- Special compounds are available from automotive supply stores for the purpose of checking differential gear tooth patterns and contact. Use this for checking the bevel gears.
- Turn the output driven shaft for 3 or 4 turns in the drive and reverse (coast) directions, while creating a drag on the drive bevel gear shaft.
- Check the drive pattern and coast pattern of the bevel gear teeth. The tooth contact patterns of both drive and coast sides should be centrally located between the top and bottom of the tooth, and a little closer to the toe of the tooth.
- ★ If the tooth contact pattern is incorrect, replace the shim(s) at the drive bevel gear and shim(s) at the driven bevel gear, following the examples shown. Then erase the tooth contact patterns, and check them again. Also check the backlash every time the shims are replaced. Repeat the shim change procedure as necessary.

NOTE

- If the backlash is out of the standard range after changing shims, correct the backlash before checking the tooth contact pattern.

Example 1: Decrease the thickness of the drive bevel gear shim(s) by 0.1 mm (0.004 in.), and/or increase the thickness of the driven bevel gear shim(s) by 0.1 mm (0.004 in.) to correct the pattern shown below. Repeat in 0.1 mm (0.004 in.) steps if necessary.

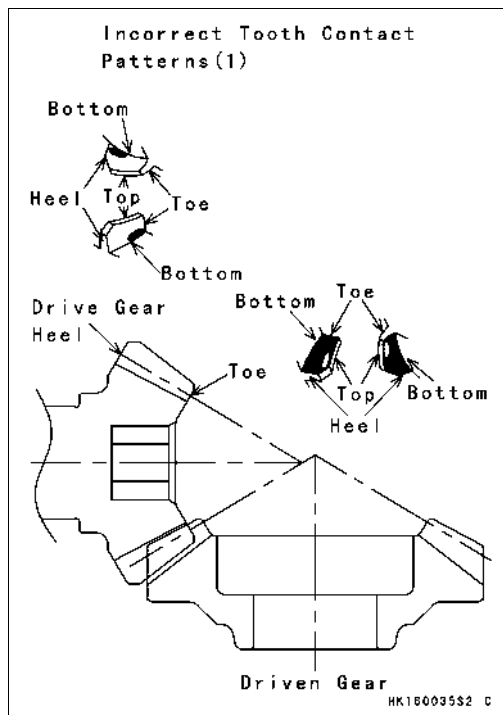
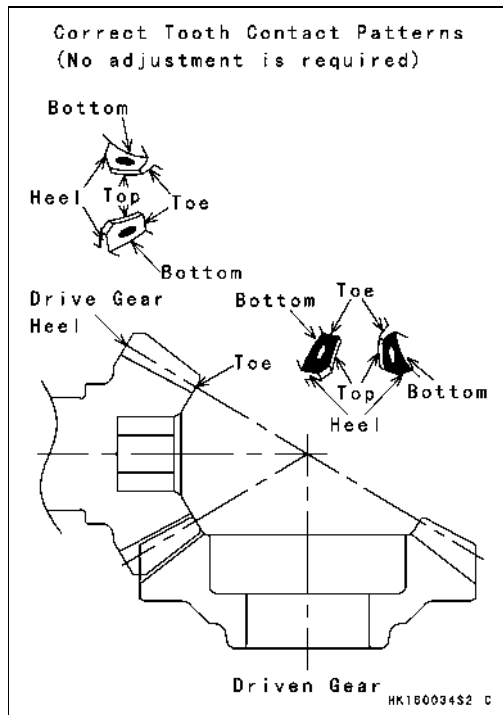

Output Bevel Gears

Example 2: Increase the thickness of the drive bevel gear shim(s) by 0.1 mm (0.004 in.), and/or decrease the thickness of the driven bevel gear shim(s) by 0.1 mm (0.004 in.) to correct the pattern shown below. Repeat in 0.1 mm (0.004 in.) steps if necessary.

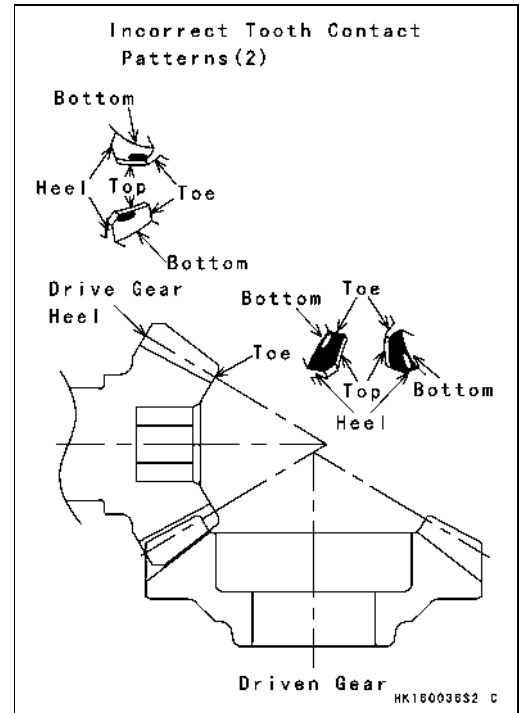

Bevel Gears Inspection

- Visually check the bevel gears [A] for scoring, chipping, or other damage.
- ★ Replace the bevel gears as a set if either gear is damaged.

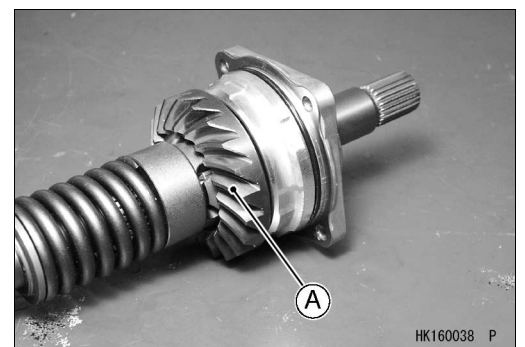
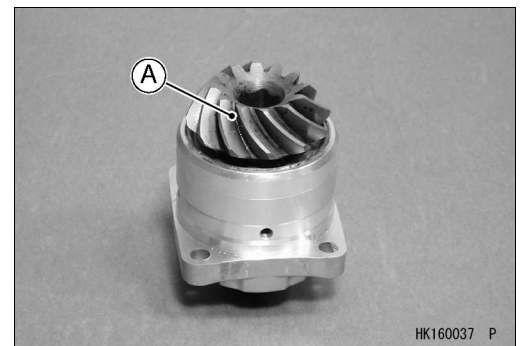

Cam Damper Inspection

- Visually inspect:
 - Bevel Gear Cam [A]
 - Cam Follower [B]
 - Spring [C]
 - Shaft [D]
- ★ Replace any part if it appears damaged.

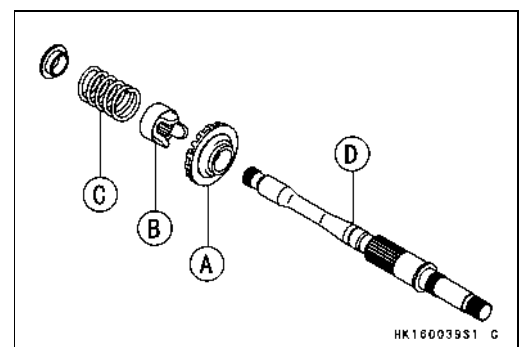

11-20 FINAL DRIVE

Front Propeller Shaft

Front Propeller Shaft Removal

- Slip the O-ring clamps off the grooves on the small rubber boots [A], and then pull the boot.

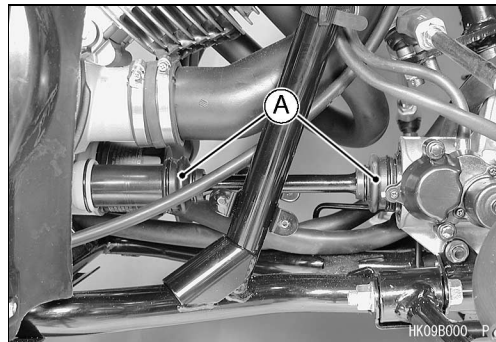

- Push the front propeller shaft [A] rearward, and remove the front end [B] from the front final gear case.
- Remove the front propeller shaft from the vehicle.

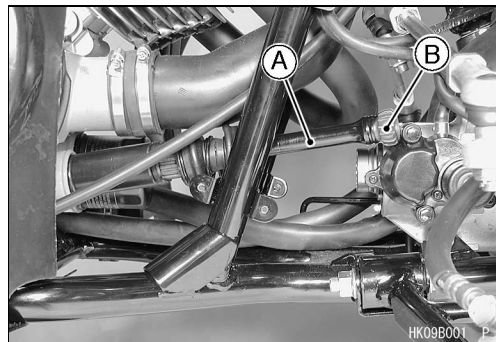

Front Propeller Shaft Installation

- Wipe any old grease off the splines of the propeller shaft [A] and the coupling [B].
- Inspect the splines of the propeller shaft and the coupling.
- ★ If the splines are twisted or damaged in any way, replace the parts as needed.
- Apply molybdenum disulfide grease to all splines.
- Replace the circlip [C] with a new one, if it is removed.
- Wipe off any old grease on the splines of the shafts on the output bevel gear and front final gear case.
- Inspect the O-rings on those shafts for damage.
- ★ If any doubt exists, replace the O-rings with new ones.
- Apply molybdenum disulfide grease to the splines of the shafts on the output bevel gear and front final gear case.
- First install the rear end, and then install the front end.
- Slip the two O-ring clamps into the groove on the small rubber boot.
 - O-ring [D]
 - Boots [E]
 - Spring [F]
 - Spring Seat [G]
 - Front [H]

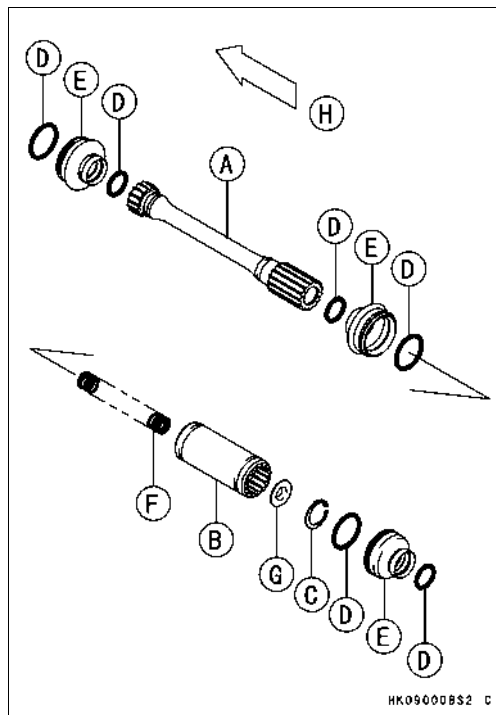

Front Axle

Front Axle Removal

- Drain the front final gear case oil (see Front Final Gear Case Oil Change in Periodic Maintenance chapter).
- Remove:
 - Front Wheel (see Wheels/Tires chapter)
 - Knuckle Joint Bolt [A]
- Remove the knuckle joint [B] from the knuckle [C].

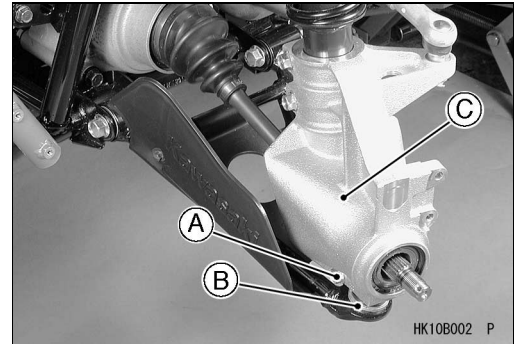

- Pull the front axle [A] in a straight line out of the front final gear case.

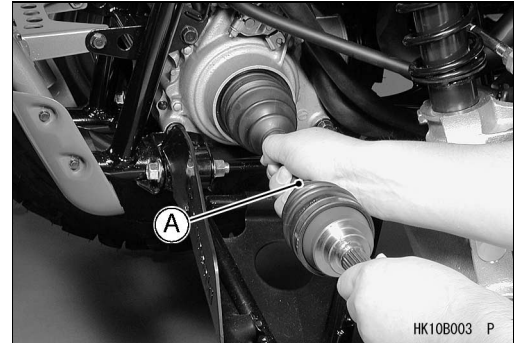

Front Axle Installation

- Wipe the old grease off the splines of the axle and the gear case oil seal.
- Visually inspect the splines of the axle.
- ★ If they are badly worn or chipped, replace the axle with a new one.
- Apply molybdenum disulfide grease to the axle splines.
- Apply grease to the gear case oil seal.
- Insert the left axle so that the teeth [A] fit in the grooves [B].

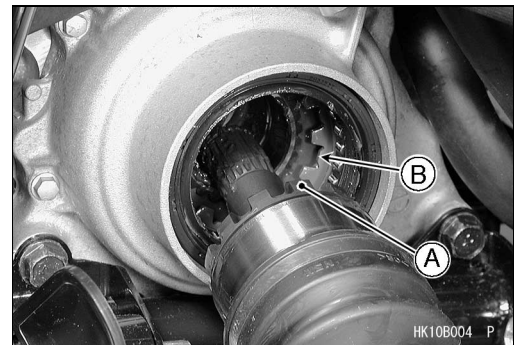

- Tap [A] the end of the front axle lightly and install the front axle.

NOTE

- *The axle shaft must not come off easily.*

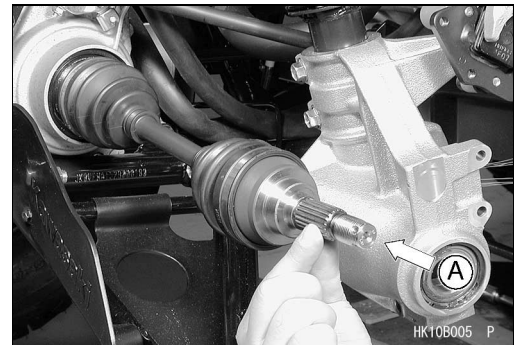

Front Axle Joint Boot Inspection

- Refer to Joint Boots Inspection in Periodic Maintenance chapter.

11-22 FINAL DRIVE

Front Axle

Front Axle Joint Boot Replacement

NOTE

- Only the inboard joint can be disassembled, so replacement of either the inboard or outboard joint boots always begins at the inboard end.

Inboard Joint Boot Removal:

- Remove the front axle (see Front Axle Removal)
- Remove the boot bands [A] of inside joint boot.
- Scrap the removed boot bands.
- Slide the joint boot towards the center [B] of the axle.

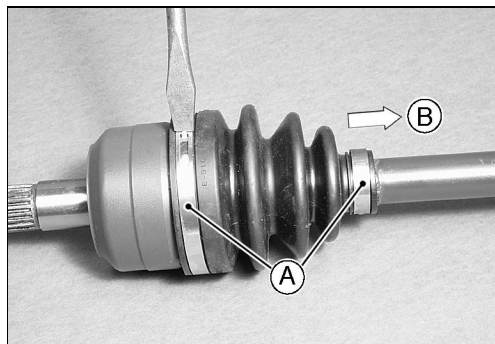

- Remove the retaining ring [A].
- Separate to the axle shaft.

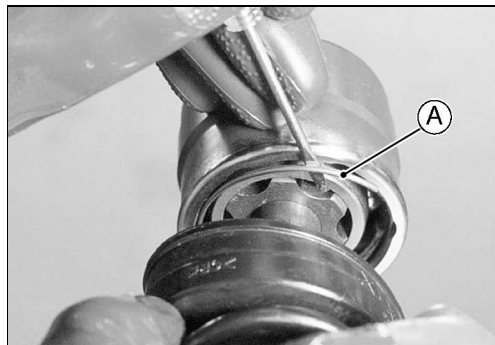

- Remove:
 - Circlip [A]
 - Ball Bearing [B]
 - Inside Joint Boot [C]

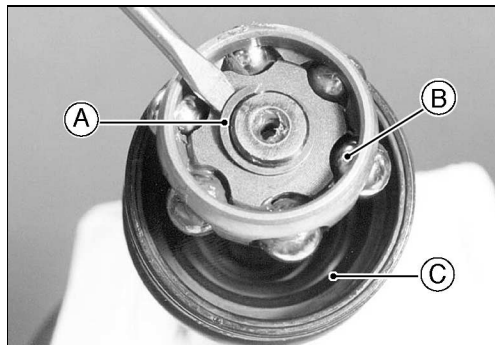

Outboard Joint Boot Replacement:

NOTE

- If inspections of the outboard joint and boot reveal no problems, do not remove the outboard boot. Move on to Inboard Joint Boot Assembly.

- Remove the boot bands of outside joint boot.
- Scrap the removed boot bands [A].

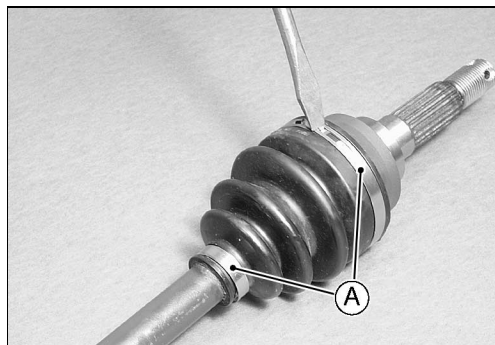

- The out side joint [A] cannot be disassembled.
- Inspect the joint bearing [B].
- ★ If the joint does not move smoothly due to wear or corrosion, replace the front axle because the joint bearing is damaged.
- Inspect whether the axle shaft spline is damaged or not.
- ★ If there is clear damage or wear on the spline, replace the axle shaft.
- Clean the axle shaft by wiping off the used grease on it.

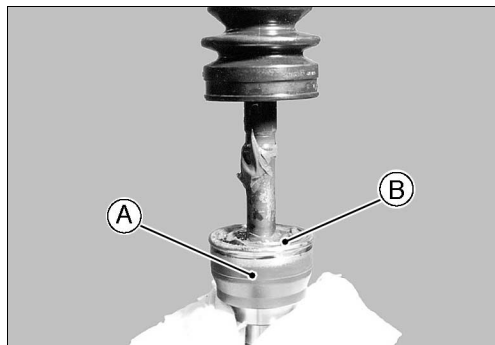

CAUTION

Do not clean the boot with the mineral oil or gasoline because they damage the boot.

Front Axle

- Wind the tape [A] on the inside splines of the axle shaft in order to protect the joint boot.
- Apply the special grease slightly on the inside of the boot small diameter, and install the joint boot on the groove of the shaft.

CAUTION
Only the special grease which is included with the boot kit can be applied to the boots.

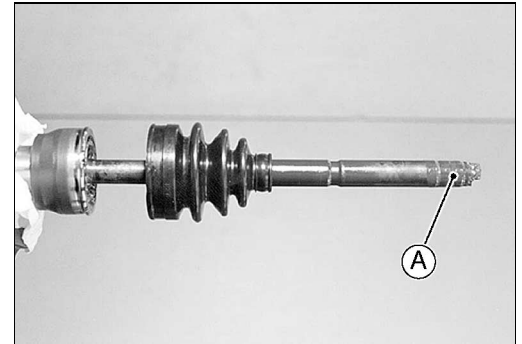

- Apply the special grease [B] slightly on the part of band installation in order to make easy to install the band [A].
- Install the small band first.

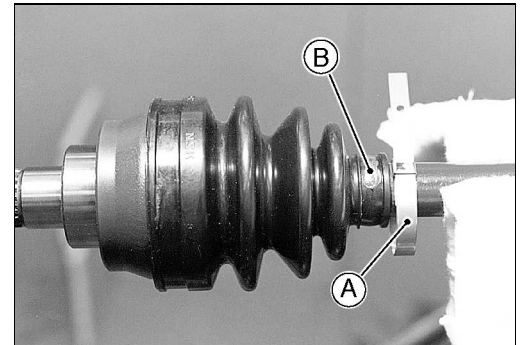

- Squeeze all of the special grease [A] (about 70 grams) into the outboard boot [B], and slide the boot onto the outside joint [C].

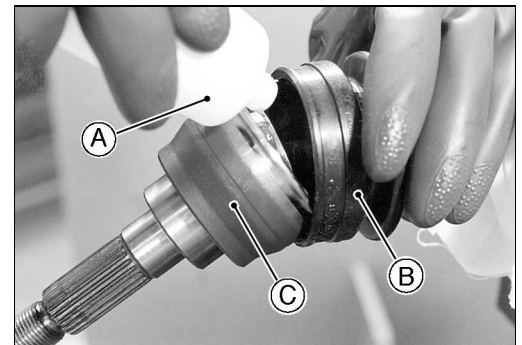

- Open the edge [A] of the boot in order to equalize the air pressures.

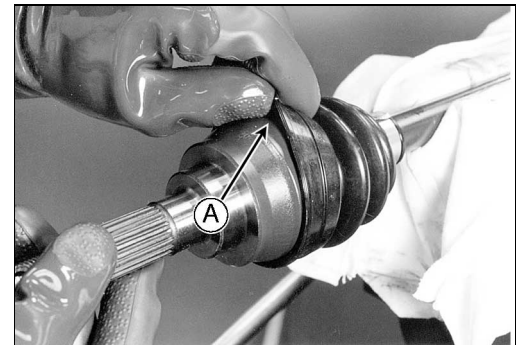

Inboard Joint Boot Assembly:

- Slide the small band [A] onto the shaft, and then slide the boot [B] into the groove [C] on the shaft.

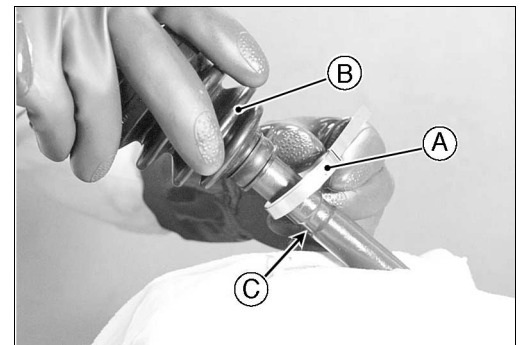

11-24 FINAL DRIVE

Front Axle

- Tighten the band, pulling the tip of band [B] with a plier and a driver, while measuring the outside diameter of the band.

Outside Diameter of Band: 26.1 ± 0.3 mm (1.028 ± 0.012 in.)
(After tightening the outside small diameter)

[A] Vernier Calipers

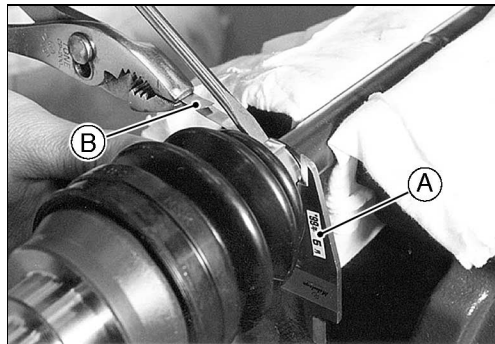

- When the outside diameter of the band comes to the specified value, bend the tip of band about 90 degrees.
- After bending the tip of band, stake it with a chisel [A] so that it does not loosen.
- After staking it, cut off the extra tip of the band, and bend it securely.

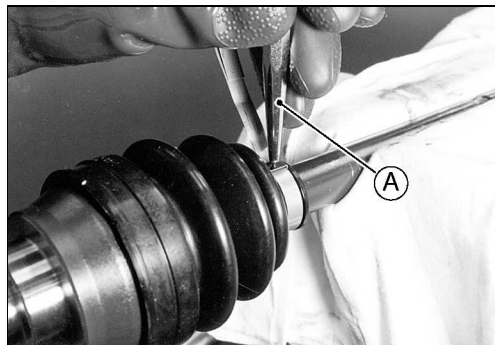

- Install the ball bearing [A] and new circlip [B].

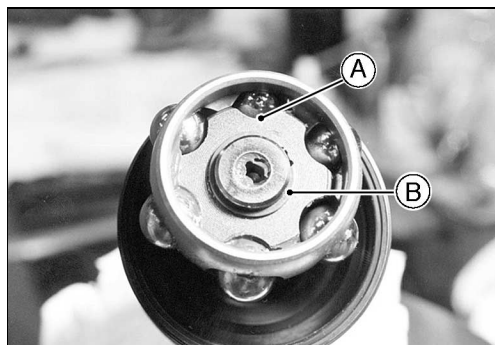

- Squeeze about half a tube (35 grams) of the special grease [A] into the inboard joint boot.

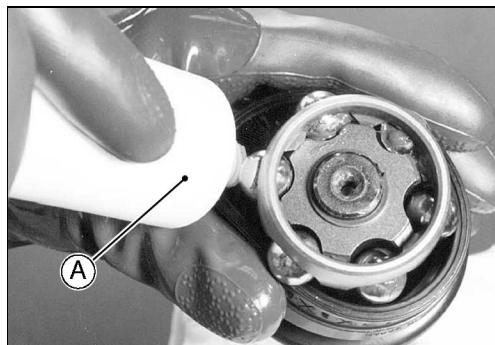

- Squeeze the remaining special grease [A] into the bearing cup [B].

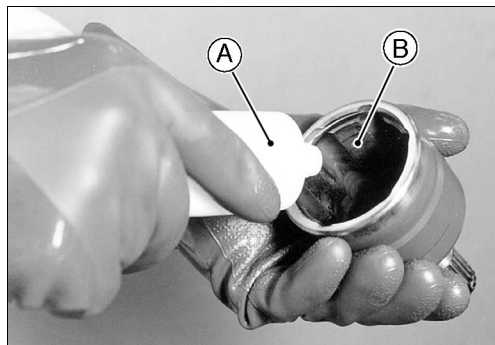

Front Axle

- Install the inside shaft, and install the new retaining ring [A].

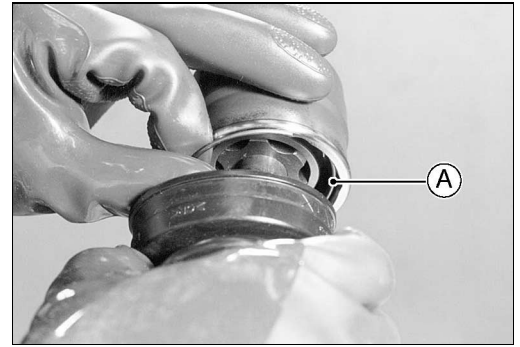

- Compress the axle assembly to the specified length while relieving the air pressure inside the inboard boot [A].
- Hold the axle at this setting.

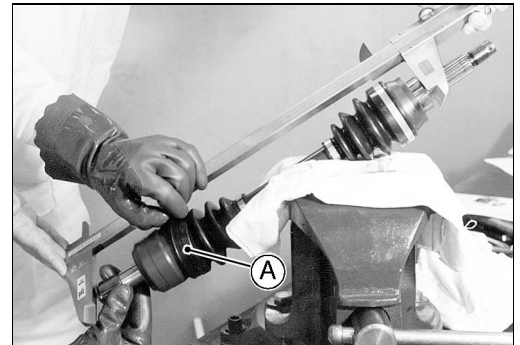

Standard Length of Assembling:

Right Front Axle: 395 mm (15.55 in.) [A]

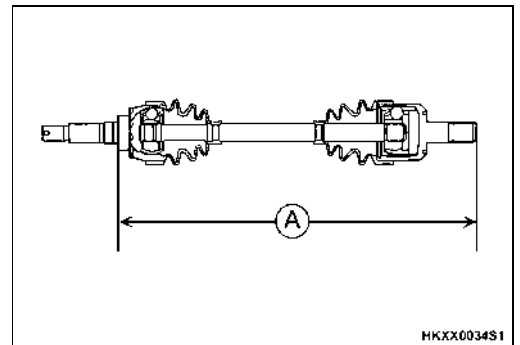

Left Front Axle: 403 mm (15.87 in.) [B]

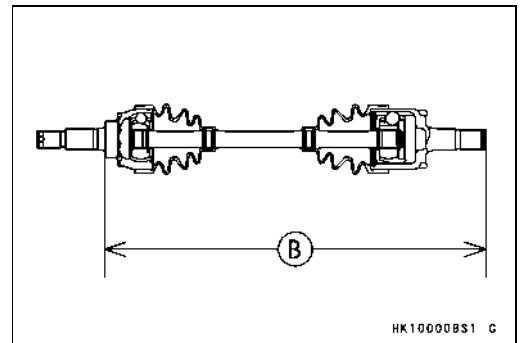

- Install the large board.
- Assemble it the same as the small band, noting this setting;

Outside Diameter of Band: 69.0 ± 0.3 mm (2.717 ± 0.012 in.)
 (After tightening the outside large diameter)

11-26 FINAL DRIVE

Front Axle

- While the band is held at the diameter above, tap down [A] the wings of the clamp.

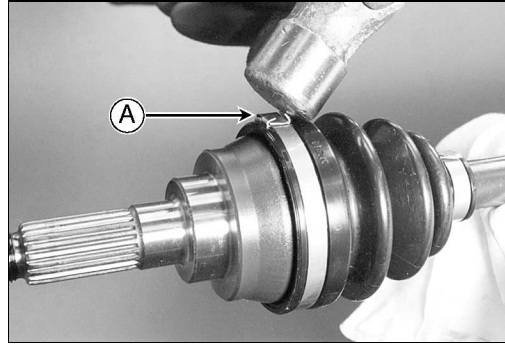

Front Final Gear Case

Front Final Gear Case Oil Level Inspection

- Park the vehicle so that it is level, both side-to-side and front-to-rear.
- Remove the filler cap.

CAUTION

Be careful not to allow any dirt or foreign materials to enter the gear case.

- Check the oil level. The oil level should come to the bottom of the filler opening [A].
- ★ If it is insufficient, first check the front final gear case for oil leakage, remedy it if necessary, and add oil through the filler opening. Use the same type and brand of oil that is already in the final gear case.
- Be sure the O-ring is in place, and tighten the filler cap.

Torque - Oil Filler Cap : 29 N·m (3.0 kgf·m, 22 ft·lb)

Front Final Gear Case Oil Change

- Refer to Front Final Gear Case Oil Change in Periodic Maintenance chapter.

Variable Differential Control Lever Position Inspection

- Refer to Variable Differential Control Lever Position Inspection in Periodic Maintenance chapter.

Variable Differential Control Lever Position Adjustment

- Refer to Variable Differential Control Lever Position Adjustment in Periodic Maintenance chapter.

Variable Differential Control Lever Removal

- Remove:
 - Plate Bolt [A]
 - Cable Stopper Plate [B]
 - Variable Differential Control Lever Bolt [C], Washer and Collar
 - Variable Differential Control Lever [D]
 - Variable Differential Control Cable Upper End

Variable Differential Control Lever Installation

- Install:
 - Variable Differential Control Cable Upper End
 - Variable Differential Control Lever [A]
 - Variable Differential Control Lever Bolt [B], Washer [C] and Collar [D]
 - Cable Stopper Plate [E]
 - Plate Bolt [F]
- Check the variable differential control lever position (see Variable Differential Control Lever Position Inspection in Periodic Maintenance chapter).

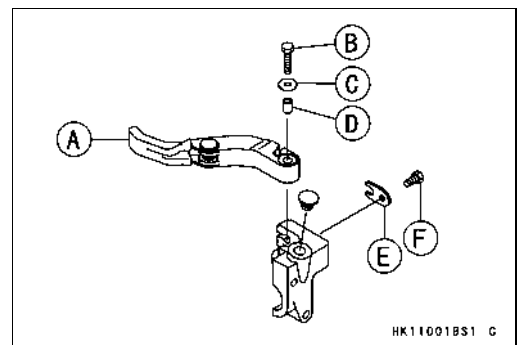
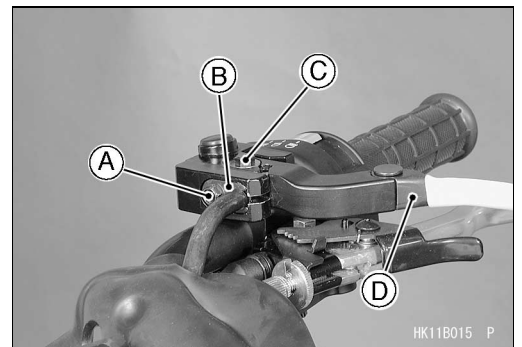
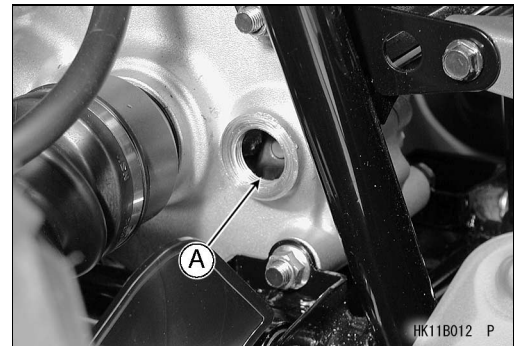

11-28 FINAL DRIVE

Front Final Gear Case

Variable Differential Control Cable Installation

- Lubricate the variable differential control cable before installation.
- Route the cable correctly according to Appendix chapter.

⚠ WARNING

Operation with an improperly adjusted, incorrectly routed, or damaged cable could result in an unsafe operating condition.

- Tighten:
Torque - Variable Differential Control Cable Locknut [A]: 17 N·m (1.7 kgf·m, 12 ft·lb)
- Check the variable differential control lever position (see Variable Differential Control Lever Position Inspection in Periodic Maintenance chapter).

Variable Differential Control Cable Lubrication

Whenever the variable differential control cable is removed, lubricate the cable as follows:

- Apply a small amount of multi-purpose grease to the cable (both ends).
- Lubricate the cable with a penetrating rust inhibitor through the pressure cable luber.

Variable Differential Control Cable Inspection

- With the variable differential control cable disconnected at both ends, the cable should move freely within the cable housing.
- ★ If the cable does not move freely after lubricating, if the cable is frayed, or if the housing is kinked, replace the cable.

Front Final Gear Case Removal

- Drain the gear case oil (see Front Final Gear Case Oil Change).
- Remove:
 - Front Propeller Shaft (see Front Propeller Shaft Removal)
 - Right and Left Front Axles (see Front Axle Removal)
 - Steering Shaft (see Steering chapter)
 - Left Suspension Arm (see Suspension chapter)
 - 2WD/4WD Actuator (see Electrical System chapter)
 - Breather Tube
 - Brake Joint Bolt [A]
- Remove:
 - Variable Front Differential Control Cable Lower End [A]
 - Front Final Gear Case Bolts [B] and Nuts
- Remove the front final gear case from the right side.

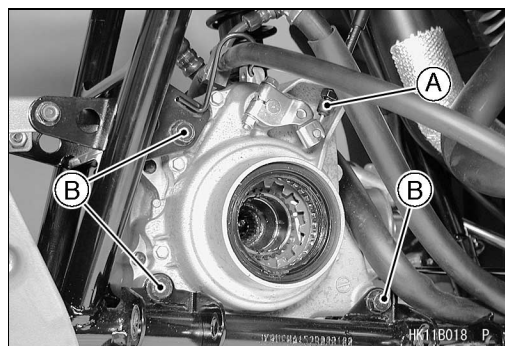
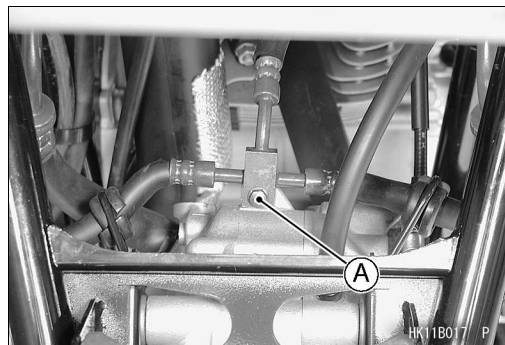
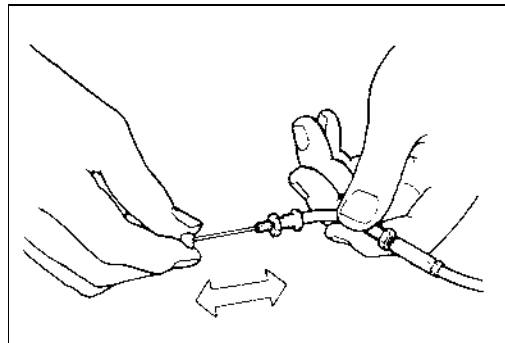
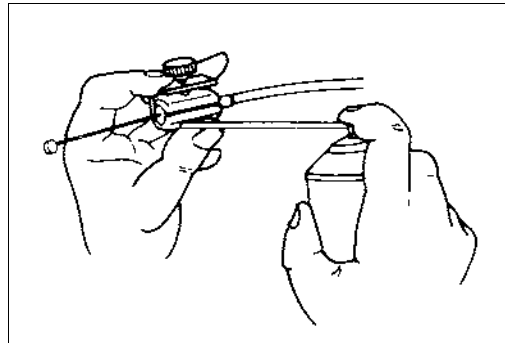
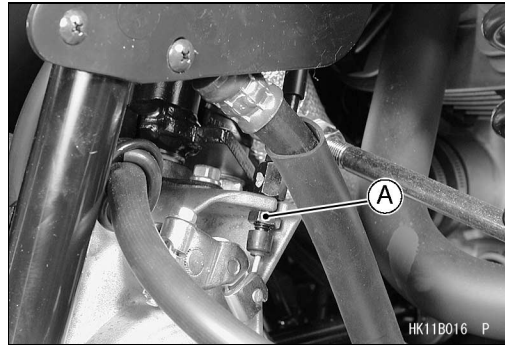

Front Final Gear Case

Front Final Gear Case Installation

- Install the gear case bolts from the vehicle left side.
Torque - Front Final Gear Case Bolts and Nuts: 42 N·m (4.3 kgf·m, 31 ft·lb)
- Install the removed parts.
- Fill the front final gear case with the specified oil (see Front Final Gear Case Oil Change in Periodic Maintenance chapter).

Front Final Gear Case Disassembly

- Remove:
 Front Final Gear Case (see Front Final Gear Case Removal)
 Variable Front Differential Control Shift Shaft Lever Bolt [A] and Nut [B]
 Variable Front Differential Control Shift Shaft Lever [C]
 2WD/4WD Actuator (see Electrical System chapter)

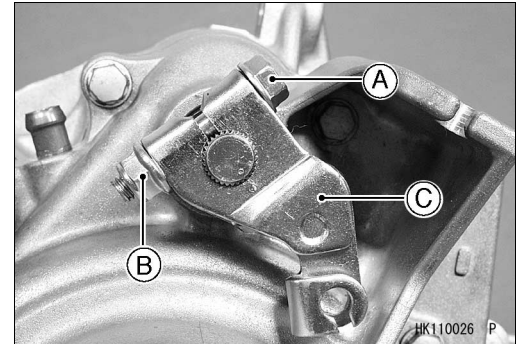

- Hold the front final gear case with the gear holder & socket wrench [A] in a vise.
Special Tool - Gear Holder & Socket Wrench, Hex 24: 57001-1489

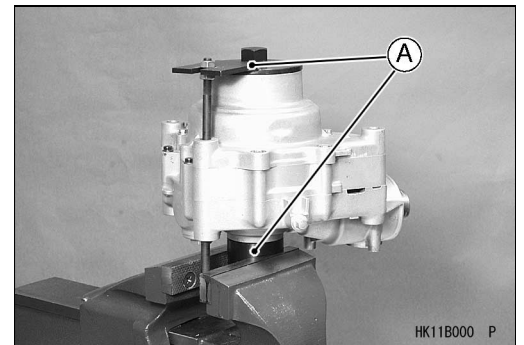

- Remove:
 Front Final Gear Case Coupling Nut [A]
 Washer [B]
 Front Final Gear Case Coupling [C]
 Shifter [D]
 Oil Seals [E]

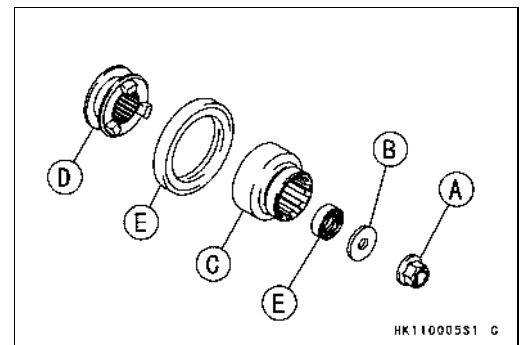

- Remove:
 Front Final Gear Case Left Cover Bolts [A]
 Front Final Gear Case Left Cover [B]
 Variable Front Differential Control Shift Shaft Spring

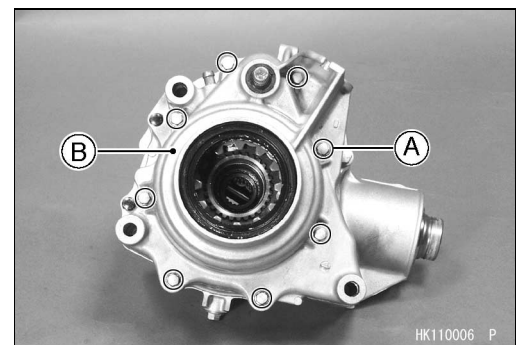

11-30 FINAL DRIVE

Front Final Gear Case

- Remove:
Outer Disc [A]
Needle Bearing

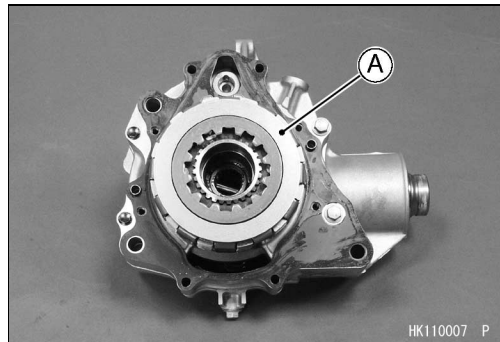

- Remove:
Housing [A] and Differential Disc Assembly [B]
Inner Disc
Needle Bearing

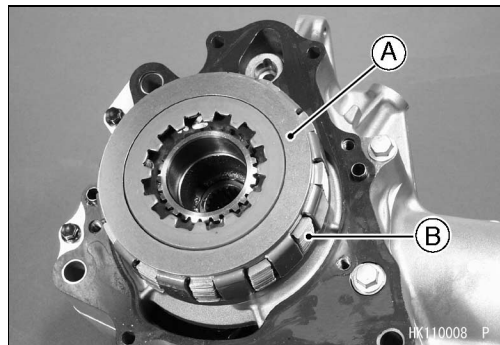

- Remove:
Cam Plate [A]



- Remove:
Steel Balls [A]
Gasket [B]
Dowel Pins [C]
Front Final Gear Case Center Cover Bolts (M6) [D]
Front Final Gear Case Center Cover Bolts (M8) [E]
Front Final Gear Case Center Cover [F]

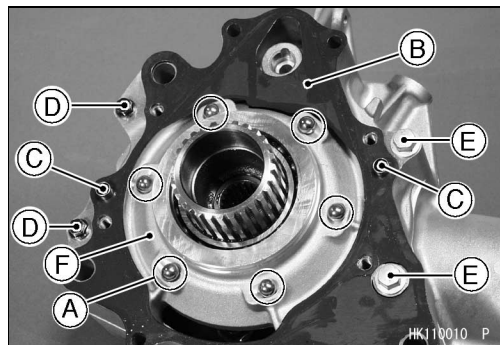

- Remove:
Ring Gear Assembly [A]
Shim(s) [B]

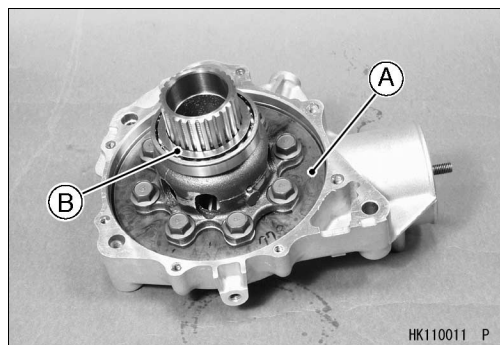

Front Final Gear Case

- Hold the front final gear case right cover [A] in a vise, and remove the bearing holder using the socket wrench [B].

Special Tool - Socket Wrench, Hex 41: 57001-1484

- If the holder seems too difficult to break free, apply heat to softer the locking agent.
- Remove:
 - Pinion Gear Bearing Holder

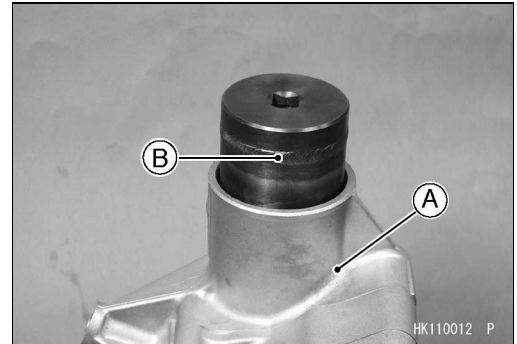

- Remove:
 - Pinion Gear Unit [A]
 - Shim(s)

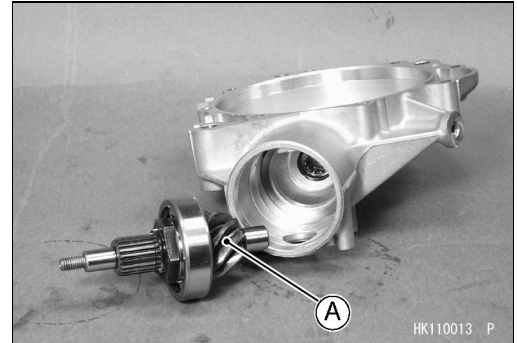

Front Final Gear Case Assembly

- Install:
 - Ball Bearing [A]
 - Needle Bearing [B]
- Press the ball bearing and needle bearing until they are bottomed.
- Install:
 - Circlip [C]
- Special Tool - Inside Circlip Pliers: 57001-143**
- Install:
 - Oil Seal [D]
- Install the oil seal until it is bottomed.

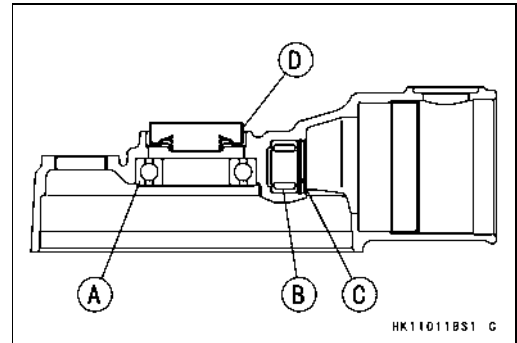

- Visually check the pinion gear and ring gear for scoring, chipping, or other damage.
- ★ Replace the bevel gear as a set if either gear is damaged since they are lapped as a set in the factory to get the best tooth contact.
- Insert the pinion gear in the front final gear case right cover.
- Install:
 - Ring Gear Assembly
- Apply grease to the O-ring [A] on the front final gear case center cover.

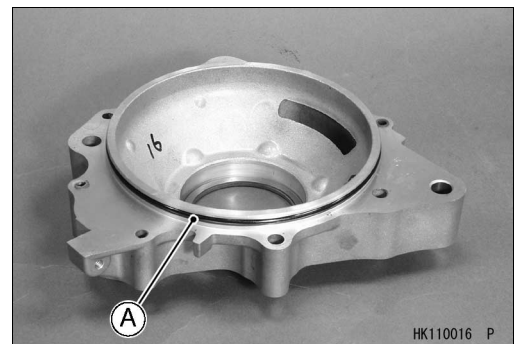

11-32 FINAL DRIVE

Front Final Gear Case

- Install:
Front Final Gear Case Center Cover [A]
 - Tighten the cover bolts following the tightening sequence as shown.
Torque - Front Final Gear Case Center Cover Bolts (M8) [1, 3]: 24 N·m (2.4 kgf·m, 17 ft·lb)
Front Final Gear Case Center Cover Bolts (M6) [2, 4]: 9.8 N·m (1.0 kgf·m, 87 in·lb)
 - Adjust the gear backlash and tooth contact pattern (see Front Final Bevel Gear Adjustment).
 - Apply a non-permanent locking agent to the cover bolts, and tighten them to the specified torque in the tightening sequence [1 ~ 4].
 - Apply a non-permanent locking agent to the pinion gear bearing holder [A], and tighten it so that the deep recess [B] faces outward.
- Special Tool - Socket Wrench, Hex 41: 57001-1484**
- Torque - Pinion Gear Bearing Holder: 137 N·m (14 kgf·m, 101 ft·lb)**

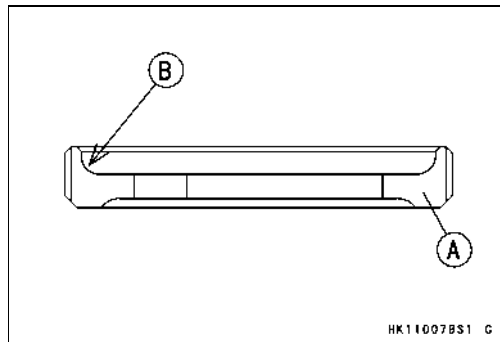
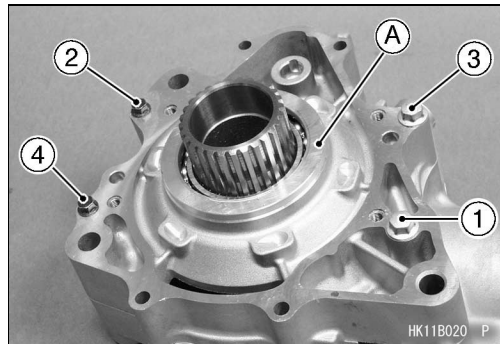

- Install:
Dowel Pins [A]
New Gasket [B]
Steel Balls [C]

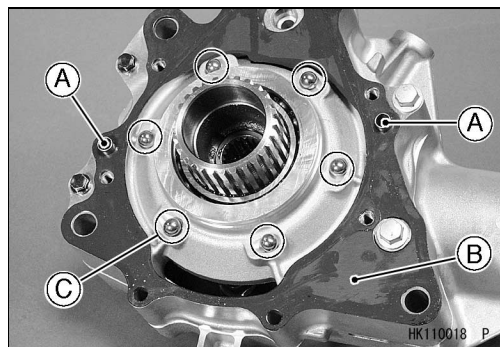

- Install:
Cam Lever [A]
Needle Bearing [B]
- Apply engine oil to the needle bearing.

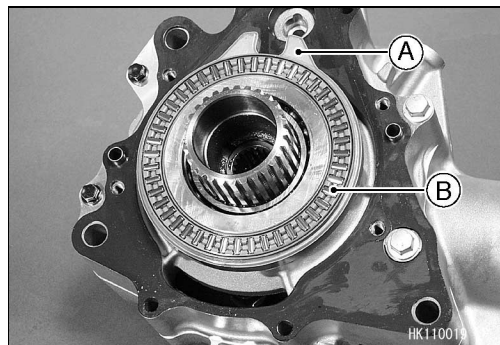

- Check the wear of the disc assembly as follows.
 - Measure the thickness of the inner disc [A].

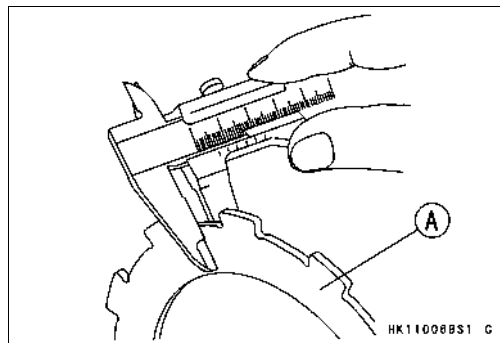

Front Final Gear Case

- Select the width [A] of the disc assembly [B] in accordance with the thickness of the inner disc, refer to the below table.

Thickness of Inner Disc Assembly	Width [A] of Disc Assembly
2.4 mm (0.0945 in.)	16.7 ~ 17.3 mm (0.6675 ~ 0.6811 in.)
1.8 mm (0.0709 in.)	17.31 ~ 17.9 mm (0.6815 ~ 0.7047 in.)
1.2 mm (0.0472 in.)	17.91 ~ 18.5 mm (0.7051 ~ 0.7283 in.)

- Measure the width of the disc assembly at three locations, and calculate average for three points.

NOTE

- Be careful not to damage the facing surface [C] on the outer plates.
 - ★ If the width is within the specified range, install the inner disc and disc assembly.
 - ★ If the width is not within the specified range, replace the disc assembly.
- Install:
 - Inner Disc [A]
 - Disc Assembly [B] and Housing [C]

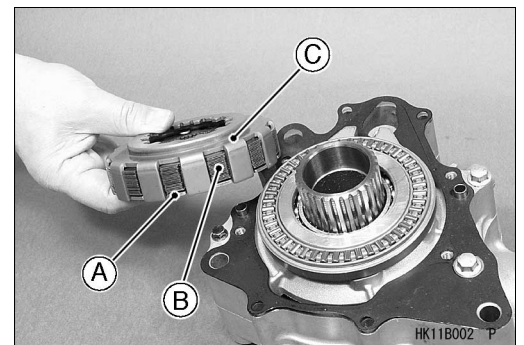
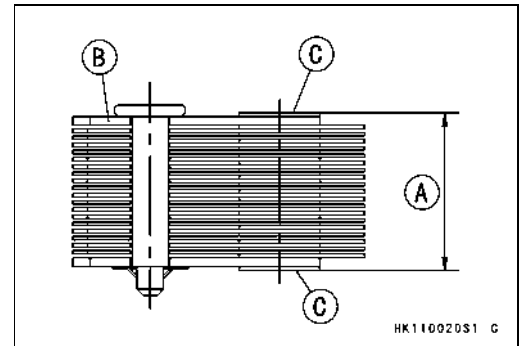

- Apply engine oil to the needle bearing [A].
- Install:
 - Needle Bearing
 - Outer Disc [B]

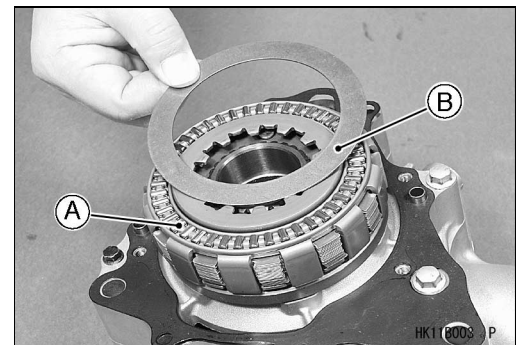

- Apply engine oil to the variable front differential control shaft [A].
- Install the shaft and spring [B] in the front final gear case left cover [C] as shown.

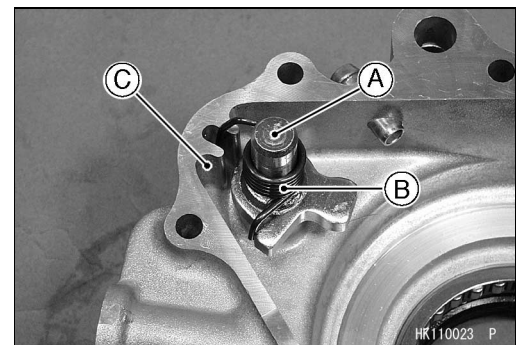

11-34 FINAL DRIVE

Front Final Gear Case

- Turn the shaft counterclockwise and insert the tab [A] of the shift shaft into the groove [B] of the cam plate.
- Install:
Front Final Gear Case Left Cover [C]

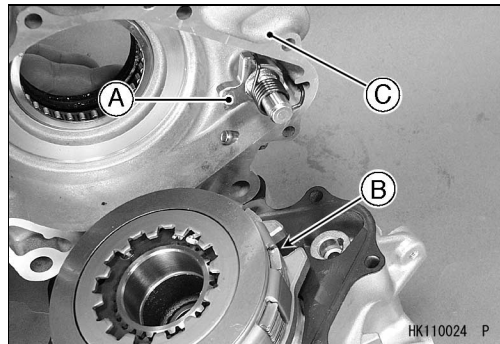

- Apply a non-permanent locking agent to the cover bolts [1 ~ 4], and tighten them following the tightening sequence as shown.

Torque - Front Final Gear Case Left Cover Bolts [1 ~ 8]: 9.8 N·m (1.0 kgf·m, 87 in·lb)

[1 ~ 4] L = 60 mm (2.4 in.)

[5 ~ 8] L = 30 mm (1.2 in.)

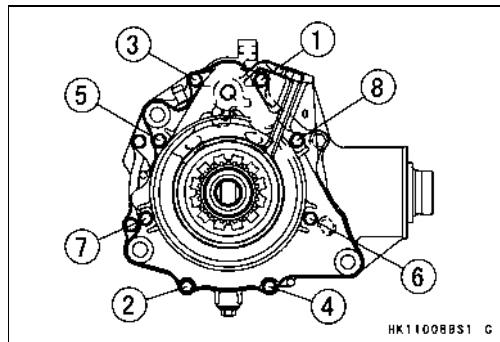

- Apply grease to the oil seal lip [A].
- Press the oil seal [B] in the coupling [C] to the specified position as shown.
[D] 1 mm (0.04 in.)

Special Tool - Oil Seal Driver, ϕ 18: 57001-1505

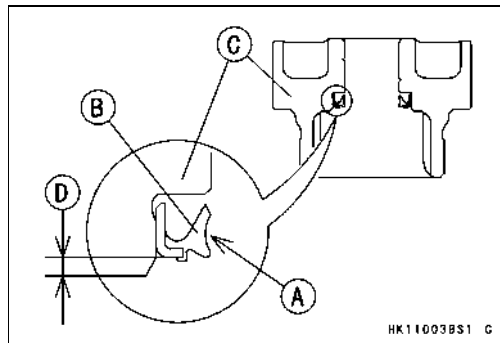

- Apply molybdenum disulfide grease to the spline [A] in the shifter [B] and inner surface [C] of the coupling.
- Install the shifter and coupling on the pinion gear shaft [D].
- Apply grease to the oil seal lip [E].
- Press the oil seal [F] in the front final gear case so that the oil seal surface is flush [G] with the case end.

Special Tool - Oil Seal Driver, ϕ 48: 57001-1506

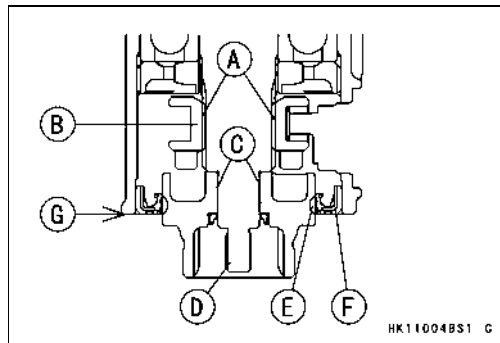

- Hold the front final gear case with the gear holder & socket wrench [A] in a vise.

Special Tool - Gear Holder & Socket Wrench, Hex 24: 57001-1489

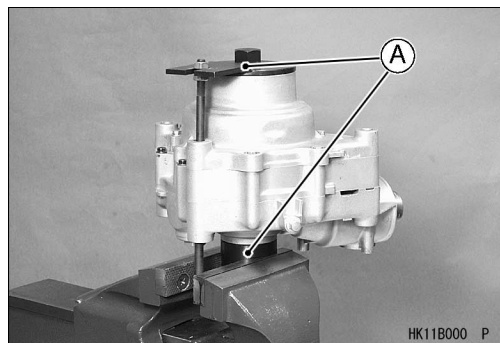

Front Final Gear Case

- Install:
 - Washer [A]
 - Front Final Gear Case Coupling Nut [B]
- Tighten:
 - Torque - Front Final Gear Case Coupling Nut: 20 N·m (2.0 kgf·m, 14 ft·lb)**

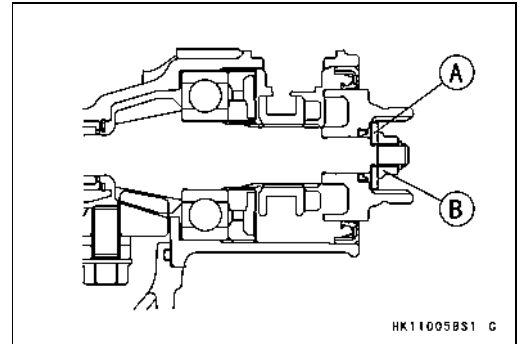

- Install the variable front differential control shaft lever [A] on the shift shaft [B] so that the punch mark [C] on the lever aligns with the punch mark [D] on the shaft as shown.
 - [E] 45.8 ~ 50.4 mm (1.803 ~ 1.984 in.)
- Tighten:
 - Torque - Variable Front Differential Control Shift Shaft Lever Bolt [F]: 8.8 N·m (0.9 kgf·m, 78 in·lb)**

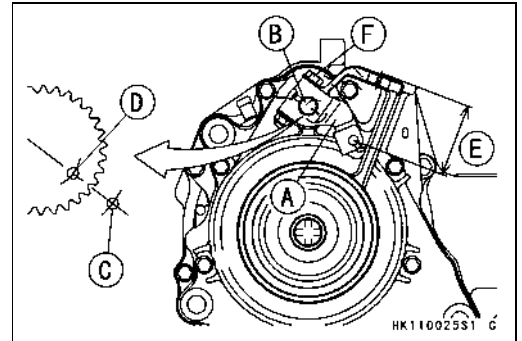

Oil Seal Installation

- Press the oil seal [A] in the front final gear case left cover [B] to the dimension as shown.
 - [C] 4.6 ~ 5.6 mm (0.18 ~ 0.22 in.)

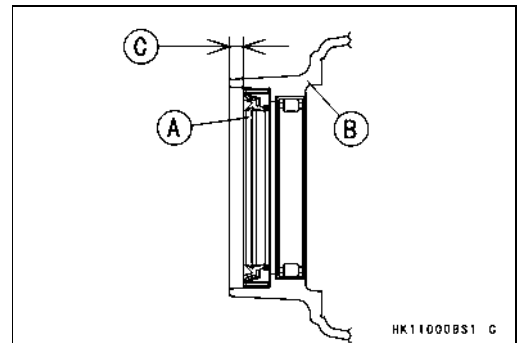

Ring Gear Disassembly

- Remove:
 - Ring Gear Assembly (see Front Final Gear Case Disassembly)
 - Ring Gear Bolts [A]
 - Ring Gear [B]

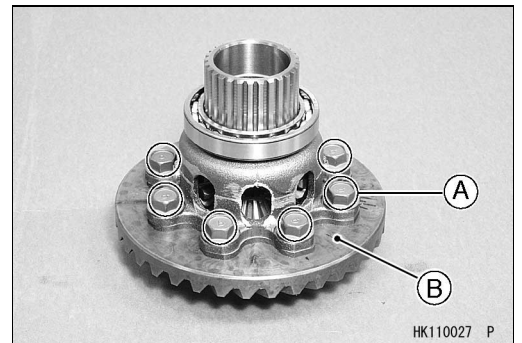

- Remove:
 - Differential Gear Cover [A]
 - Right Side Gear (16T) [B]
 - Pins [C]
 - Spider Gear Shaft [D]
 - Spider Gears (10T) [E]
 - Left Side Gear (16T) [F]
 - Left Differential Gear Case [G]

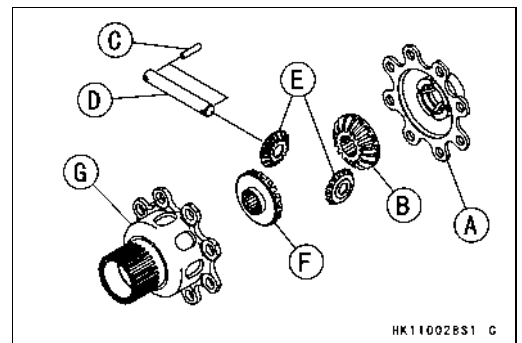

11-36 FINAL DRIVE

Front Final Gear Case

Ring Gear Assembly

- Press the bearing [A] on the left differential gear case [B] until it is bottomed.
- Apply engine oil [C] to the spider gears.
- Apply molybdenum disulfide grease [D] to the spline in the side gear (16T) [E].
- Install:
 - Left Side Gear (16T)
 - Spider Gears (10T) [F]
 - Spider Gear Shaft [G] and Pins [H]

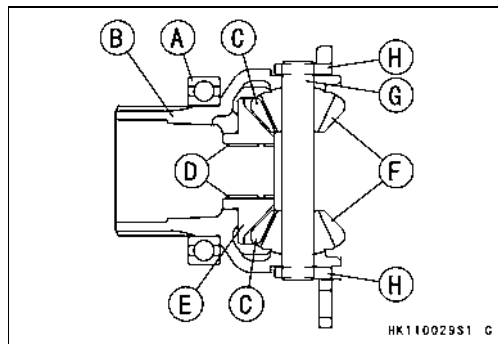

- Apply engine oil [A] to the spider gears.
- Apply molybdenum disulfide grease [B] to the spline in the side gear (16T) [C].
- Install:
 - Side Gear (16T)
 - Differential Gear Case Cover [D]
 - Ring Gear [E]
- Apply a non-permanent locking agent (Three Bond: TB2471 Blue) to the ring gear bolts [F], and tighten them.

Torque - Ring Gear Bolts: 57 N·m (5.8 kgf·m, 42 ft·lb)

NOTE

- Keep the ring gear assembly at more than 20°C (68°F) for six hours after tightening the bolts.

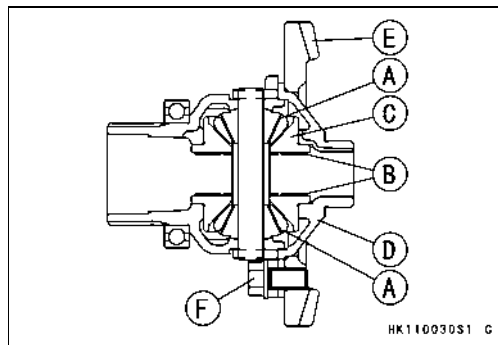

LSD Clutch Torque Inspection

- ★ If the vehicle has the following symptoms, check the LSD (Limited Slip Differential) clutch torque.
 - The handlebar is hard to turn.
 - The front final gear case overheats.
 - Abnormal noises come from the front final gear case when rounding a curve.
- Ensure 2WD mode.
- Support the vehicle so that the front wheels are off the ground.
- Remove:
 - One Front Wheel (see Wheels/Tires chapter)
 - Front Axle Nut Cotter Pin
- Secure the other-side front wheel from rotating.
- Measure the clutch torque using a torque wrench [A]. Turn the wrench evenly.
- The clutch torque is the mean torque reading during about a quarter turn of the wrench.

LSD Clutch Torque (When variable differential control lever is released.)
Standard: 15 ~ 20 N·m (1.5 ~ 2.0 kg·m, 11 ~ 14 ft·lb)

LSD Clutch Torque (When variable differential control lever is pulled in.)
Standard: 157 N·m (16 kg·m, 116 ft·lb) or more

- ★ If the clutch torque is out of the specified range, check the width of the disc assembly (see Front Final Gear Case Assembly).

NOTE

- The correct type of oil must be installed.

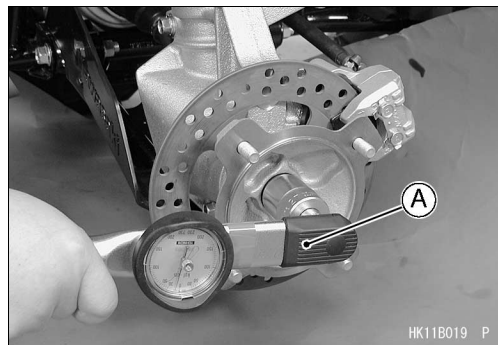

Front Final Gear Case

Pinion Gear Unit Disassembly

- Remove:
 - Pinion Gear Unit (see Front Final Gear Case Disassembly)
- Pry open the staking of the pinion gear bearing holder nut with a small chisel.
- Hold the pinion gear unit [A] with the pinion gear holder [B] in a vise, and remove the pinion gear bearing holder nut [C].

Special Tool - Pinion Gear Holder: 57001-1485

- Remove the ball bearing only if required.

Special Tool - Bearing Puller: 57001-135

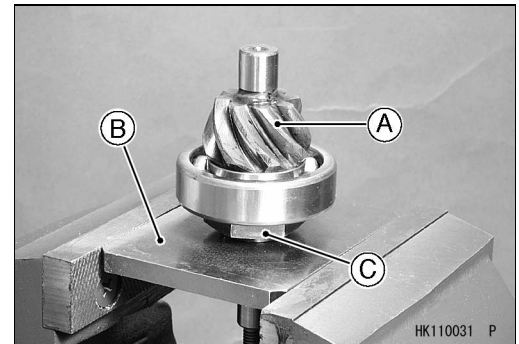

Pinion Gear Unit Assembly

- The pinion gear and ring gear are lapped as a set in the factory to get the best tooth contact. They must be replaced as a set.
- Visually inspect the bearing for abrasion, color change, or other damage.
- ★ If there is any doubt as to the condition of a bearing, replace the bearing.
- Be sure to check and adjust the bevel gear backlash and tooth contact, when any of the backlash-related parts are replaced (see Front Final Bevel Gear Adjustment).
- Press the bearing on the pinion gear until it is bottomed.

- Install the pinion gear bearing holder nut [A] so that the projection [B] faces outward.

- Tighten:

Special Tool - Pinion Gear Holder: 57001-1485

Torque - Pinion Gear Bearing Holder Nut : 127 N·m (13 kgf·m, 94 ft·lb)

- Stake [C] the nut with a punch at three positions to secure it.

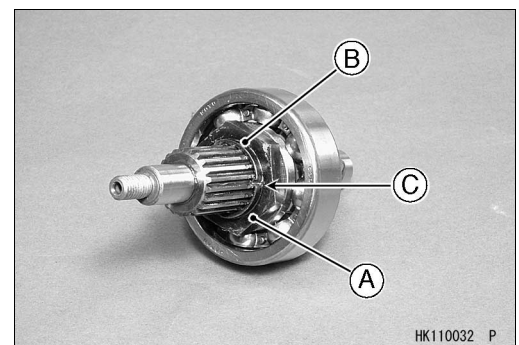

Front Final Bevel Gear Adjustment

The **backlash** (distance one gear will move back and forth without moving the mate gear) and **tooth contact pattern** of the bevel gears must be correct to prevent the gears from making noise and being damaged.

Above two adjustments are of critical importance and must be carried out following the correct sequence and method.

- When any one of the backlash-related parts are replaced, check and adjust the bevel gear backlash, and tooth contact by replacing shims.
- The amount of backlash is influenced by the ring gear position more than by the pinion gear position.
- Tooth contact location is influenced by the pinion gear position more than by the ring gear position.

Front Final Bevel Gear Adjustment Procedure

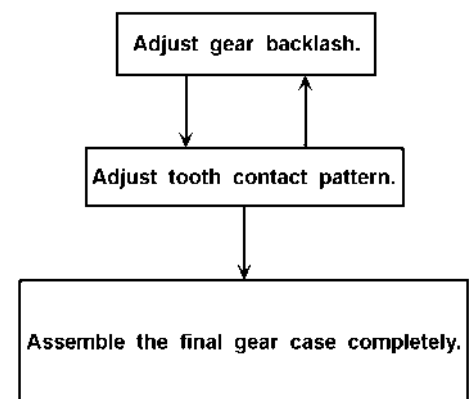

11-38 FINAL DRIVE

Front Final Gear Case

Front Final Gear Case (Backlash-related Parts)

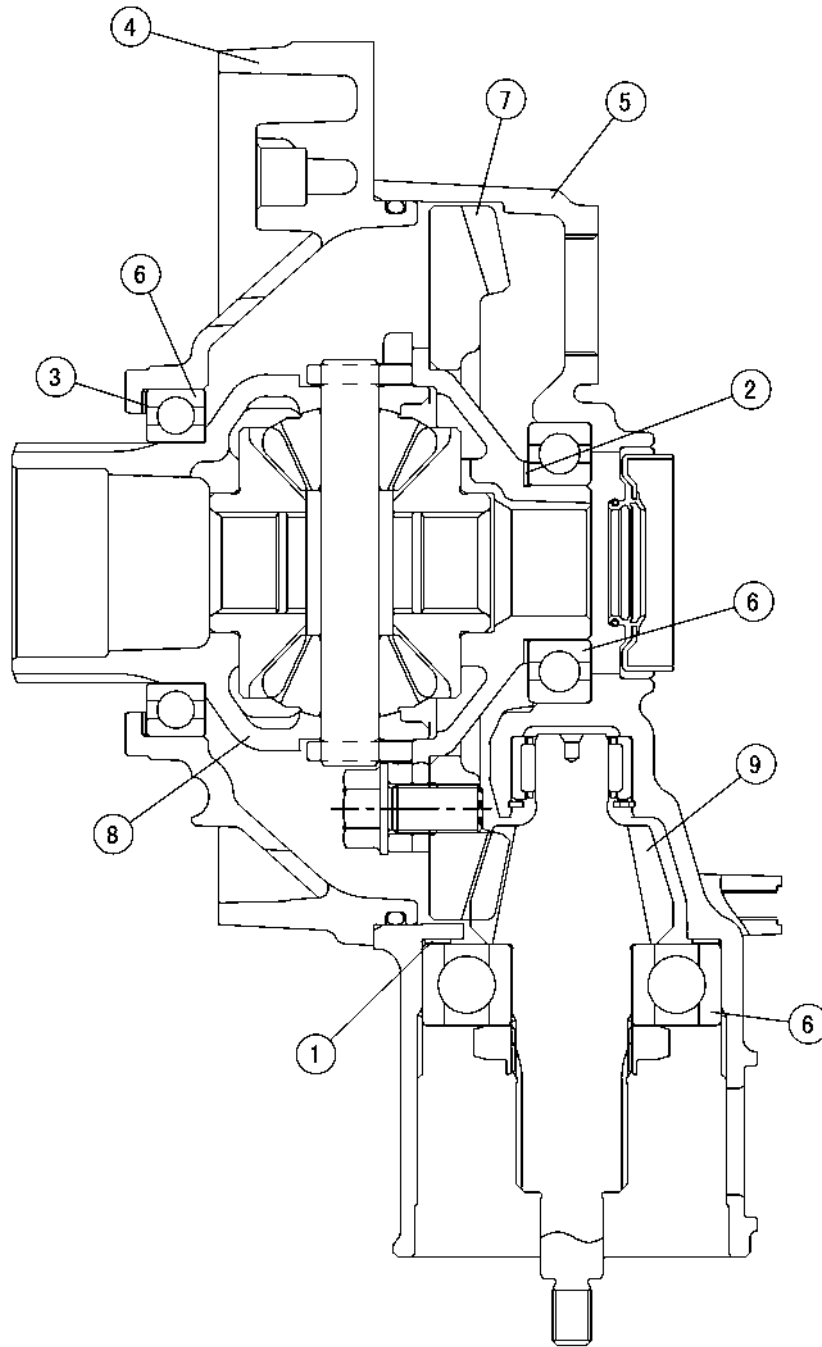

HK110033W4 C

- 1. Pinion Gear Shim(s)
- 2. Ring Gear Right Shim(s)
- 3. Ring Gear Left Shim(s)

- 4. Front Final Gear Case Center Cover
- 5. Front Final Gear Case Right Cover

- 6. Ball Bearings
- 7. Ring Gear
- 8. Ring Gear Assembly
- 9. Pinion Gear

Front Final Gear Case

1. Pinion Gear Shims for Backlash Adjustment

Thickness	Part Number
0.15 mm (0.006 in.)	92180-1325
0.2 mm (0.008 in.)	92180-1327
0.5 mm (0.020 in.)	92180-1326
0.7 mm (0.028 in.)	92180-1384
0.8 mm (0.031 in.)	92180-1328
0.9 mm (0.035 in.)	92180-1385
1.0 mm (0.039 in.)	92180-1337
1.1 mm (0.043 in.)	92180-1386
1.2 mm (0.047 in.)	92180-1338

2. Ring Gear Right Shims for Tooth Contact Adjustment

Thickness	Parts Number
0.15 mm (0.006 in.)	92180-1331
0.2 mm (0.008 in.)	92180-1332
0.5 mm (0.020 in.)	92180-1329
0.7 mm (0.028 in.)	92180-1381
0.8 mm (0.031 in.)	92180-1330
0.9 mm (0.035 in.)	92180-1382
1.0 mm (0.039 in.)	92180-1339
1.1 mm (0.043 in.)	92180-1383
1.2 mm (0.047 in.)	92180-1340

3. Ring Gear Left Shims for Tooth Contact Adjustment

Thickness	Parts Number
0.15 mm (0.006 in.)	92180-1334
0.2 mm (0.008 in.)	92180-1336
0.5 mm (0.020 in.)	92180-1335
0.7 mm (0.028 in.)	92180-1387
0.8 mm (0.031 in.)	92180-1333
0.9 mm (0.035 in.)	92180-1388
1.0 mm (0.039 in.)	92180-1341
1.1 mm (0.043 in.)	92180-1389
1.2 mm (0.047 in.)	92180-1342

11-40 FINAL DRIVE

Front Final Gear Case

Backlash Adjustment

- Check and adjust the gear backlash when any of the backlash-related parts are replaced with new ones.
- Clean any dirt and oil off the bevel gear teeth.
- Assemble the front final gear case (see Front Final Gear Case Assembly).
- It is not necessary to install the variable front differential control unit.
- Check the backlash during tightening of the front final gear case center cover bolts and stop tightening them immediately if the backlash disappears. Then, change the ring gear shim to a thicker one.
- Temporarily, install the right front axle in the gear case and hold it in a vise so that the ring gear is lower than the pinion gear.
- Mount a dial gauge [A] so that the tip of the gauge is against the splined portion [B] of the pinion gear shaft.
- To measure the backlash, move the pinion gear shaft back and forth [C] while holding the front axle steady. The difference between the highest and the lowest gauge reading is the amount of backlash.
- Measure backlash at three locations equally spaced on the splines.

Front Final Bevel Gear Backlash

Standard: 0.10 ~ 0.20 mm (0.004 ~ 0.008 in.) (at pinion gear spline)

- ★ If the backlash is not within the limit, replace the pinion gear shims. To increase backlash, increase the thickness of the shim(s). To decrease backlash, decrease the thickness of the shim(s).
- Change the thickness a little at a time.
- Recheck the backlash, and readjust as necessary.

Tooth Contact Adjustment

- Clean any dirt and oil off the bevel gear teeth.
- Apply checking compound to 4 or 5 teeth on the pinion gear.

NOTE

- Apply checking compound to the teeth in a thin, even coat with a fairly stiff paint brush. If painted too thickly, the exact tooth pattern may not appear.
 - The checking compound must be smooth and firm, with the consistency of tooth paste.
 - Special compounds are available from automotive supply stores for the purpose of checking differential gear tooth patterns and contact. Use one of these for checking the bevel gears.
- Assemble the front final gear case (see Front Final Gear Case Assembly).
 - It is not necessary to install the variable front differential control unit.
 - Turn the pinion gear shaft [A] for one revolution in the drive and reverse (coast) direction, while creating a drag on the ring gear.
 - Remove the ring gear and pinion gear unit to check the drive pattern and coast pattern of the bevel gear teeth.

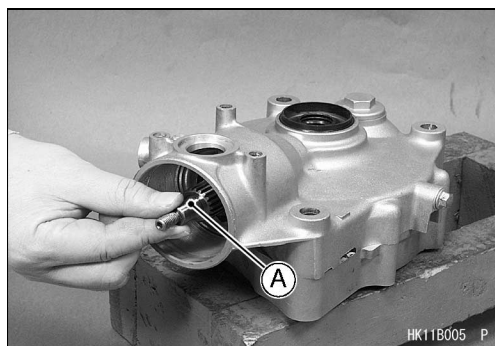
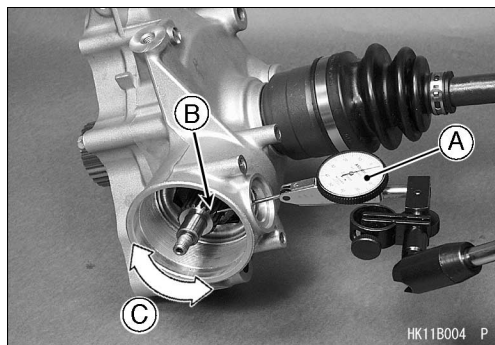

Front Final Gear Case

- The tooth contact patterns of both (drive and coast) sides should be centrally located between the top and bottom of the tooth. The drive pattern can be a little closer to the toe and the coast pattern can be a somewhat longer and closer to the toe.
- ★ If the tooth contact pattern is incorrect, replace the ring gear shim(s), following the examples shown.
- Then erase the tooth contact patterns and check them again. Also check the backlash every time the shim(s) are replaced. Repeat the shim change procedure as necessary.

NOTE

- If the backlash is out of the standard range after changing the ring gear shim(s), change the pinion gear shim(s) to correct the backlash before checking the tooth contact pattern.

Bevel Gear Inspection

- Visually check the bevel gears [A] for scoring, chipping, or other damage.
- ★ Replace the bevel gears as a set if either gear is damaged.

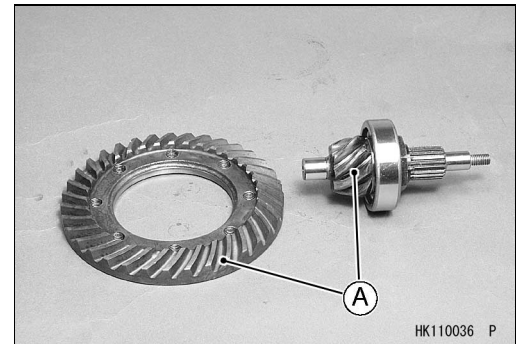

Differential Gear Inspection

- Visually check the differential gears [A] for scoring, chipping, or other damage.
- ★ Replace the differential gears as a set if either gear is damaged.
- Also, inspect the differential gear shaft [B], gear case [C], and cover [D] where the differential gears rub.
- ★ If they are scored, discolored, or otherwise damaged, replace them as a set.

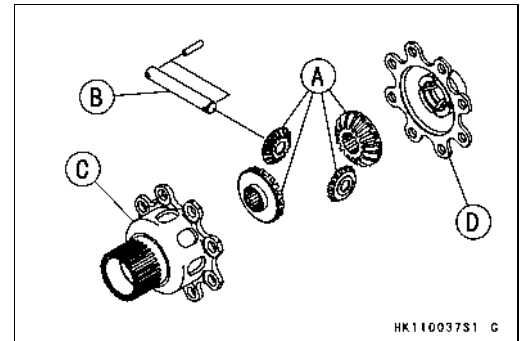

11-42 FINAL DRIVE

Front Final Gear Case

Correct Tooth Contact Pattern: No adjustment is required.

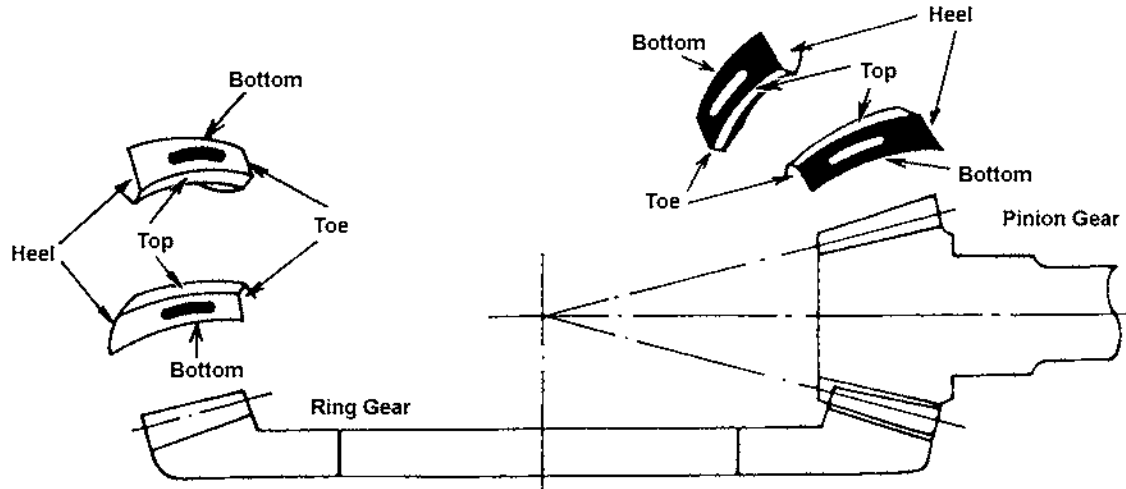

Incorrect Tooth Contact Patterns

Example 1 : Decrease the thickness of the ring gear shim(s) by 0.1 mm (0.004 in.) to correct the pattern shown below. Repeat in 0.1 mm (0.004 in.) steps if necessary.

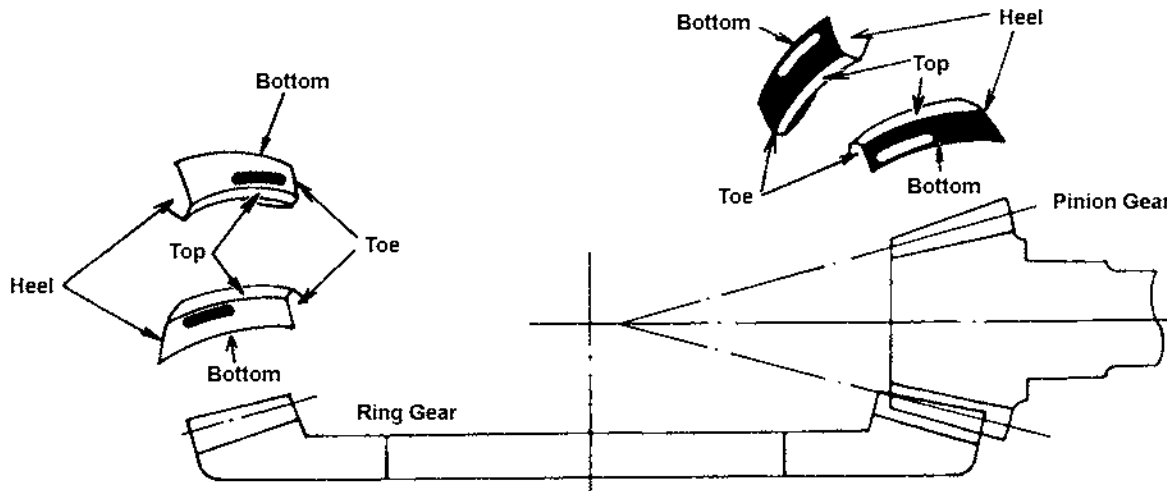

Example 2 : Increase the thickness of the ring gear shim(s) by 0.1 mm (0.004 in.) to correct the pattern shown below. Repeat in 0.1 mm (0.004 in.) steps if necessary.

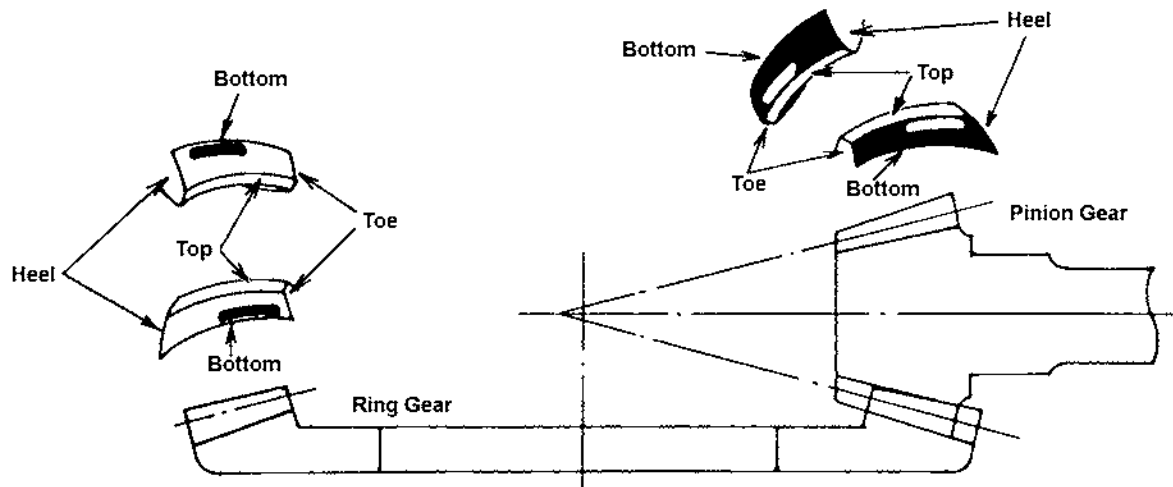

Rear Propeller Shaft

Rear Propeller Shaft Removal

- Drain the rear final gear case oil (see Rear Final Gear Case Oil Change in Periodic Maintenance chapter).
- Remove:
 - Swingarm [A] (see Suspension chapter)
 - Rear Propeller Shaft [B]

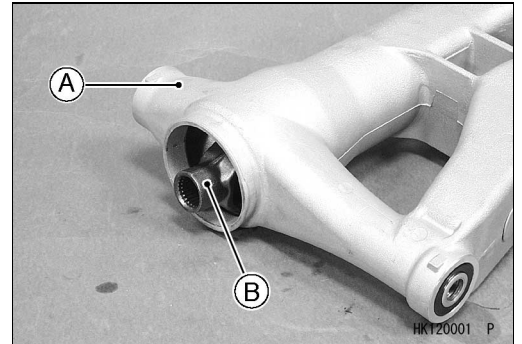

Rear Propeller Shaft Installation

- Wipe the old grease off the front and rear end splines [A] of the rear propeller shaft [B] and apply new molybdenum disulfide grease in those.
- Be sure to install the spring [C] on the pinion gear nut of the rear final gear case.
- Install the rear propeller shaft while aligning the splines.

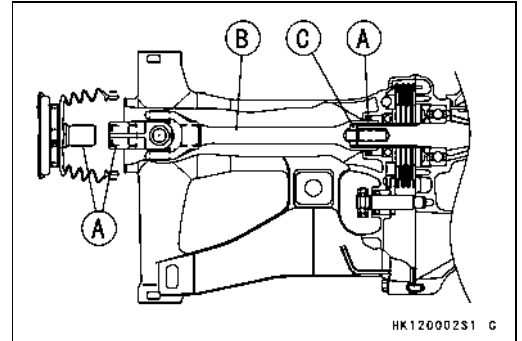

Rear Propeller Shaft Joint Boot Inspection

- Refer to Joint Boots Inspection in Periodic Maintenance chapter.

Rear Propeller Shaft Inspection

- Remove the rear propeller shaft (see Rear Propeller Shaft Removal).
- Check that the universal joint [A] works smoothly without rattling or sticking.
- ★ If it does rattle or stick, the universal joint is damaged. Replace the propeller shaft with a new one.
- Visually inspect the splines [B] on the propeller shaft.
- ★ If they are badly worn, chipped, or loose, replace the propeller shaft.
- Also, inspect the splines on the rear end of the output shaft and the pinion gear joint in the final gear case.
- ★ If splines are badly worn, chipped, or loose, replace the output shaft and the pinion gear joint.

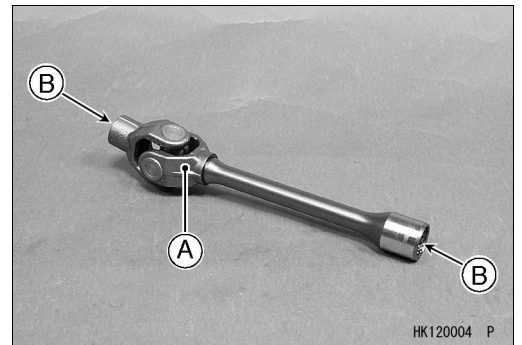

11-44 FINAL DRIVE

Rear Axle

Rear Axle Removal

- Drain the rear final gear case oil (see Rear Final Gear Case Oil Change in Periodic Maintenance chapter).
- Remove:
 - Rear Wheels (see Wheels/Tires chapter)
 - Rear Hub (see Wheels/Tires chapter)
 - Rear Bottom Guard (see Frame chapter)
 - Trailer Hitch Bracket (see Frame chapter)
 - Rear Final Gear Case Left Cover
- Tap [A] the right end of the rear axle [B] and pull it out from the left.
- The left axle bearing comes off with the axle.

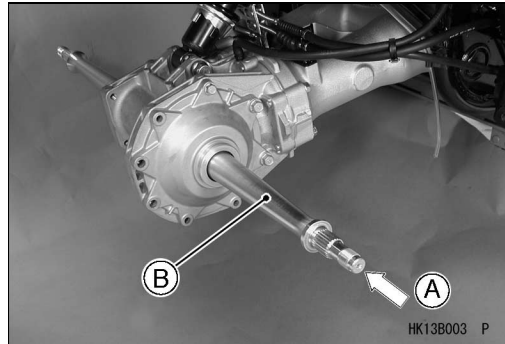

Rear Axle Installation

- Install the rear axle from the left side with the left bearing installed, while aligning the splines.
- Apply grease:
 - O-ring [A]
 - Oil Seal Lips in Rear Final Gear Case Left Cover
- Install:
 - Rear Final Gear Case Left Cover [A]
 - Trailer Hitch Bracket [B] (see Frame chapter)

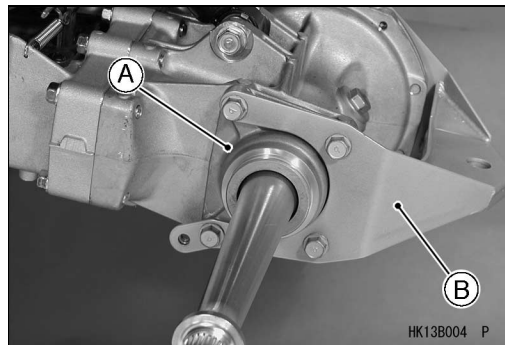
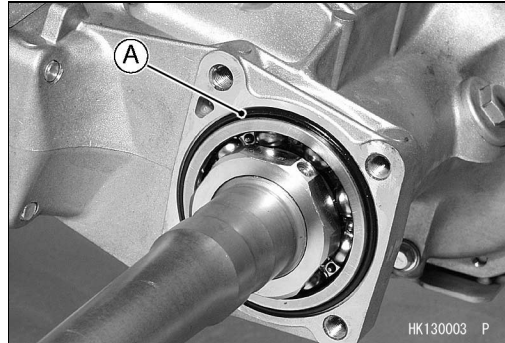

Ball Bearing Wear

CAUTION

Do not remove the bearing [A] for inspection. Removal may damage it.

- Check the ball bearing.
- Since the ball bearing is made to extremely close tolerances, the wear must be judged by feel rather than measurement.
- Spin the bearing by hand to check its condition.
- ★ If the bearing is noisy, does not spin smoothly, or has any rough spots, replace the rear axle shaft.

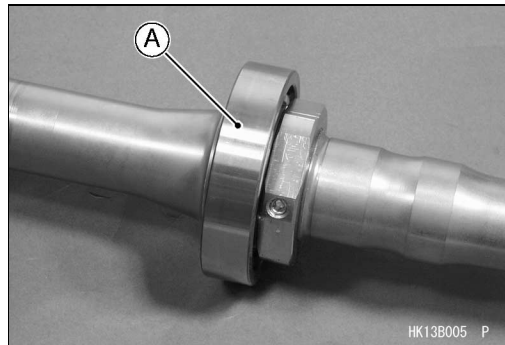

Rear Axle Runout Inspection

- Visually inspect the axle for damage.
- ★ If the axle is damaged or bent, replace it.
- Set the rear axle in an alignment jig or on V blocks, and place a dial gauge [A] against the middle point.
- Turn the axle slowly. The difference between the highest and lowest dial gauge readings is the axle runout (TIR).
- ★ If the runout exceeds the service limit, replace the axle.

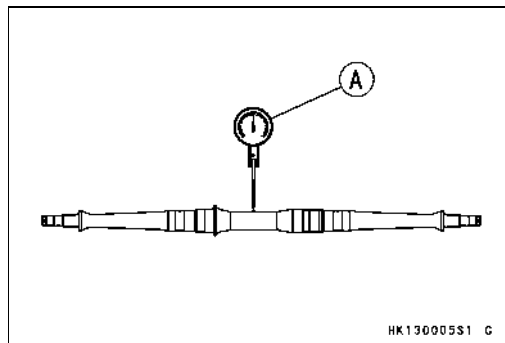

Rear Axle Shaft Runout

- Standard: TIR 1 mm (0.04 in.) or less
Service Limit: TIR 2 mm (0.08 in.)

Rear Final Gear Case

Rear Final Gear Case Oil Level Inspection

- Park the vehicle so that it is level, both side-to-side and front-to-rear.
- Remove the filler cap.

CAUTION

Be careful not to allow any dirt or foreign materials to enter the gear case.

- Check the oil level. The oil level should come to the bottom of the filler opening [A].

★ If it is insufficient, first check the rear final gear case for oil leakage, remedy it if necessary, and add oil through the filler opening. Use the same type and brand of oil that is already in the final gear case.

- Apply grease to the O-ring.
- Be sure the O-ring is in place.

Torque - Oil Filler Cap: 29 N·m (3.0 kgf·m, 22 ft·lb)

Rear Final Gear Case Oil Change

- Refer to Rear Final Gear Case Oil Change in Periodic Maintenance chapter.

Rear Final Gear Case Removal

- Remove:
 - Rear Shock Absorber (see Suspension chapter)
 - Rear Brake Cable Ends [A]
 - Vent Hose [B]

- Remove:
 - Rear Axle [A] (see Rear Axle Removal)
 - Rear Final Gear Case Bolts [B] (10)
 - Rear Final Gear Case [C]

Rear Final Gear Case Installation

- Install:
 - Rear Axle Shaft [A]
 - Dowel Pins [B]
 - New Gasket [C] (see Brake System chapter)
 - Spring [D]
- Insert the pinion gear shaft of the rear final gear case in the plate assembly.
- Align the splines by rotating the axle shaft.

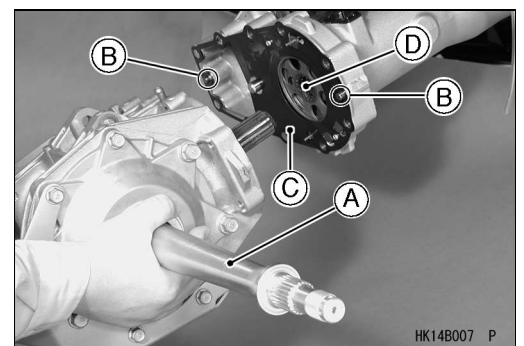
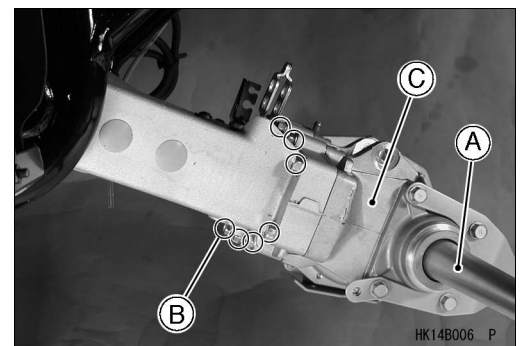
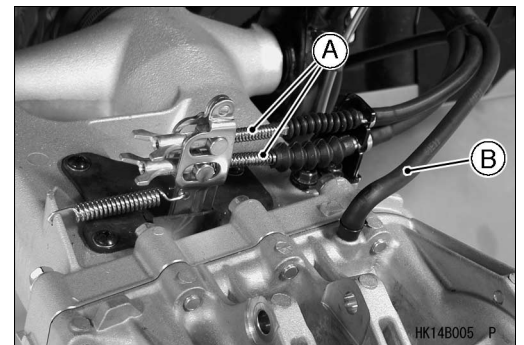

11-46 FINAL DRIVE

Rear Final Gear Case

- Tighten the rear final gear case bolts following the tightening sequence [1 ~ 10].

Torque - Rear Final Gear Case Bolts: 42 N·m (4.3 kgf·m, 31 ft·lb)

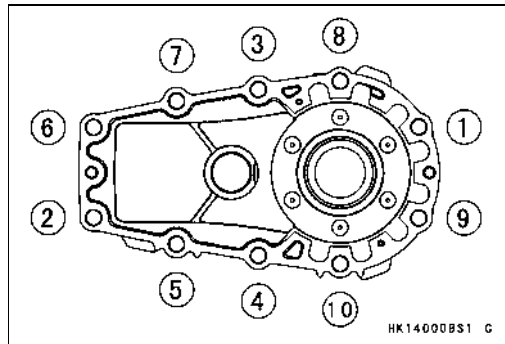

Rear Final Gear Case Disassembly

- Remove:
 - Rear Final Gear Case (see Rear Final Gear Case Removal)
 - Rear Final Gear Case Right Cover Bolts [A]
 - Rear Final Gear Case Right Cover [B]

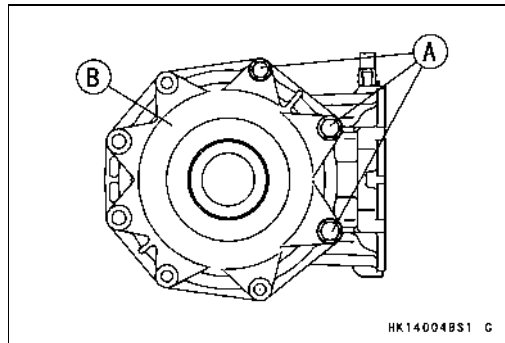

- Remove:
 - Shim(s) [A]
 - Ring Gear [B]

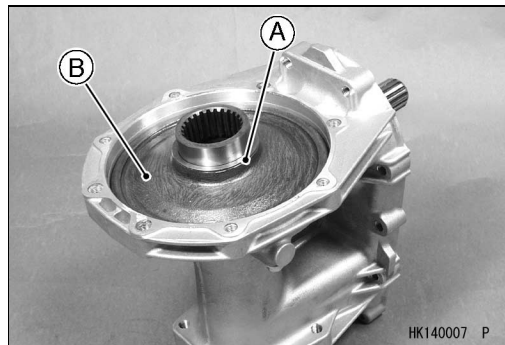

- Remove:
 - Pinion Gear Bearing Holder [A]

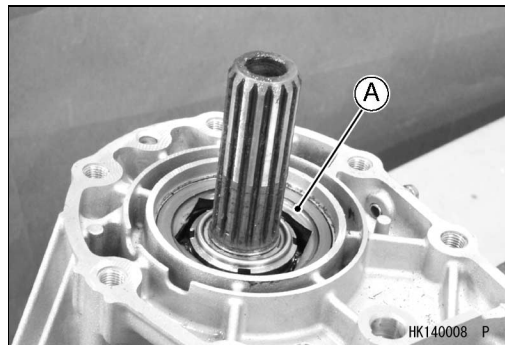

- Hold the rear final gear case [A] in a vise, and remove the bearing holder using the socket wrench [B].

Special Tool - Socket Wrench, Hex 50: 57001-1478

- If the holder seems too difficult to break free, apply heat to softer the locking agent.

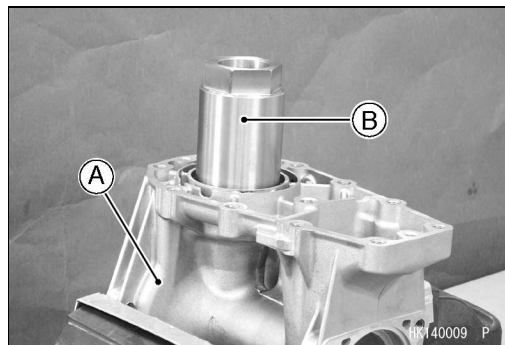

Rear Final Gear Case

- Remove:
 - Pinion Gear Unit [A]
 - Shim(s)

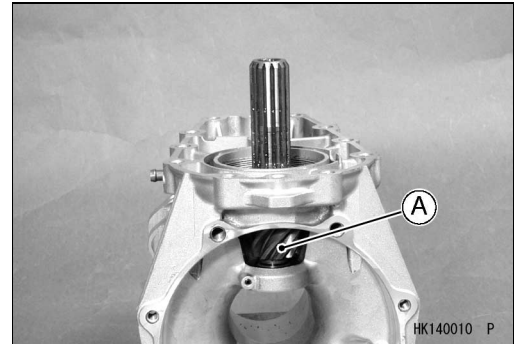

Rear Final Gear Case Assembly

- Visually check the pinion gear and ring gear for scoring, chipping, or other damage.
- ★ Replace the bevel gear as a set if either gear is damaged since they are lapped as a set in the factory to get the best tooth contact.
- Install:
 - Shim(s)
 - Pinion Gear Unit
- Be sure to check and adjust the bevel gear backlash and tooth contact when any of the backlash-related parts are replaced (see Rear Final Bevel Gear Adjustment).
- Apply a non-permanent locking agent to the pinion gear bearing holder [A], and tighten it.

Special Tool - Socket Wrench, Hex 50: 57001-1478

Torque - Pinion Gear Bearing Holder: 137 N·m (14 kgf·m, 101 ft·lb)

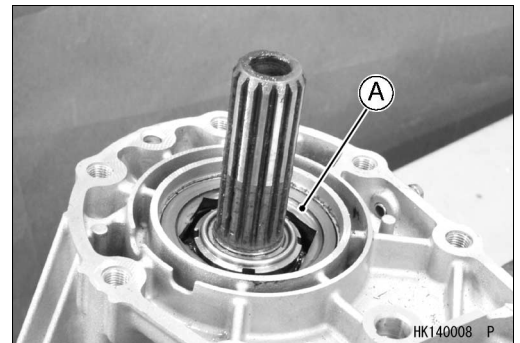

- Inspect:
 - Ball Bearing [A] (see Bearing and Oil Seal section)
 - Oil Seals [B] (see Bearing and Oil Seal section)
- ★ If they are damaged, replace the rear final gear case right cover [C].
- Apply grease to the oil seal lips and O-ring [D].

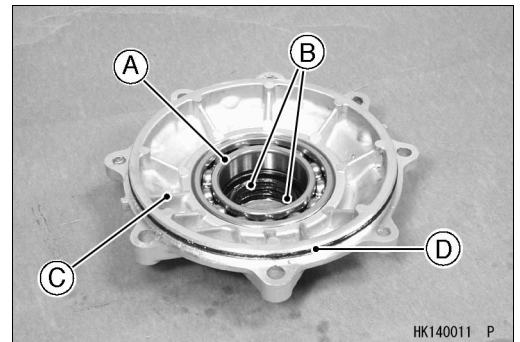

- Install:
 - Rear Final Gear Case Right Cover [A]
- Apply a non-permanent locking agent to the cover bolts, and tighten them.
 - Torque - Rear Final Gear Case Right Cover Bolts (M10) [B]: 49 N·m (5.0 kgf·m, 36 ft·lb)**
 - Rear Final Gear Case Right Cover Bolts (M8) [C]: 24 N·m (2.4 kgf·m, 17 ft·lb)**

- Install:
 - Rear Final Gear Case Left Cover
 - Rear Axle (see Rear Axle Installation)
 - Trailer Hitch Bracket (see Frame chapter)

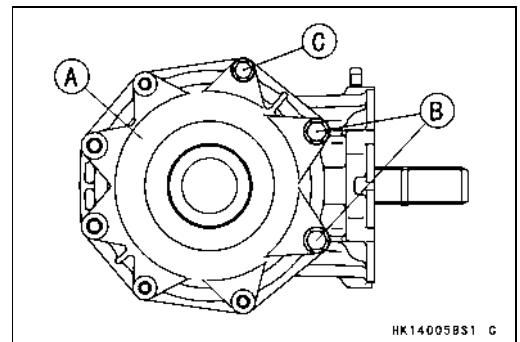

11-48 FINAL DRIVE

Rear Final Gear Case

Oil Seal Installation

- Press the oil seals in the right and left covers to the specified positions as shown.

[A] Left Cover

[B] Outside Oil Seal

[C] 31.5 ~ 32.5 mm (1.24 ~ 1.28 in.)

[D] Inside Oil Seal

[E] 21.3 ~ 22.3 mm (0.84 ~ 0.88 in.)

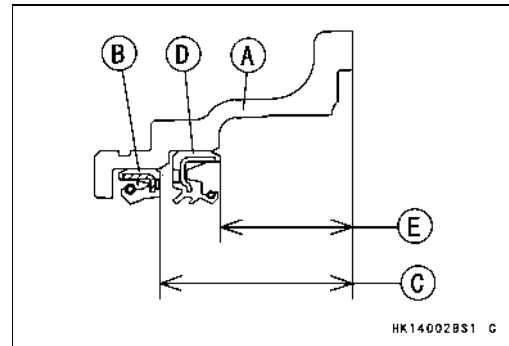

- Use the oil seal driver [A] for the outside oil seals of the right and left covers.

Special Tool - Oil Seal Driver: 57001-1487

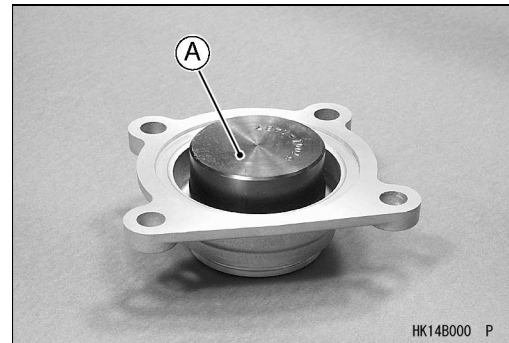

Rear Final Gear Case

Rear Final Bevel Gear Adjustment

- The **backlash** and **tooth contact pattern** of the bevel gears must be correct to prevent the gears from making noise and being damaged.
- After replacing any of the backlash-related parts, be sure to check and adjust the backlash and tooth contact of the bevel gears. First, adjust backlash, and then tooth contact by replacing shims.
- The amount of backlash is influenced by the ring gear position more than by the pinion gear position.
- Tooth contact locations is influenced by the pinion gear position more than by the ring gear position.

Rear Final Gear Case (Backlash-related Parts)

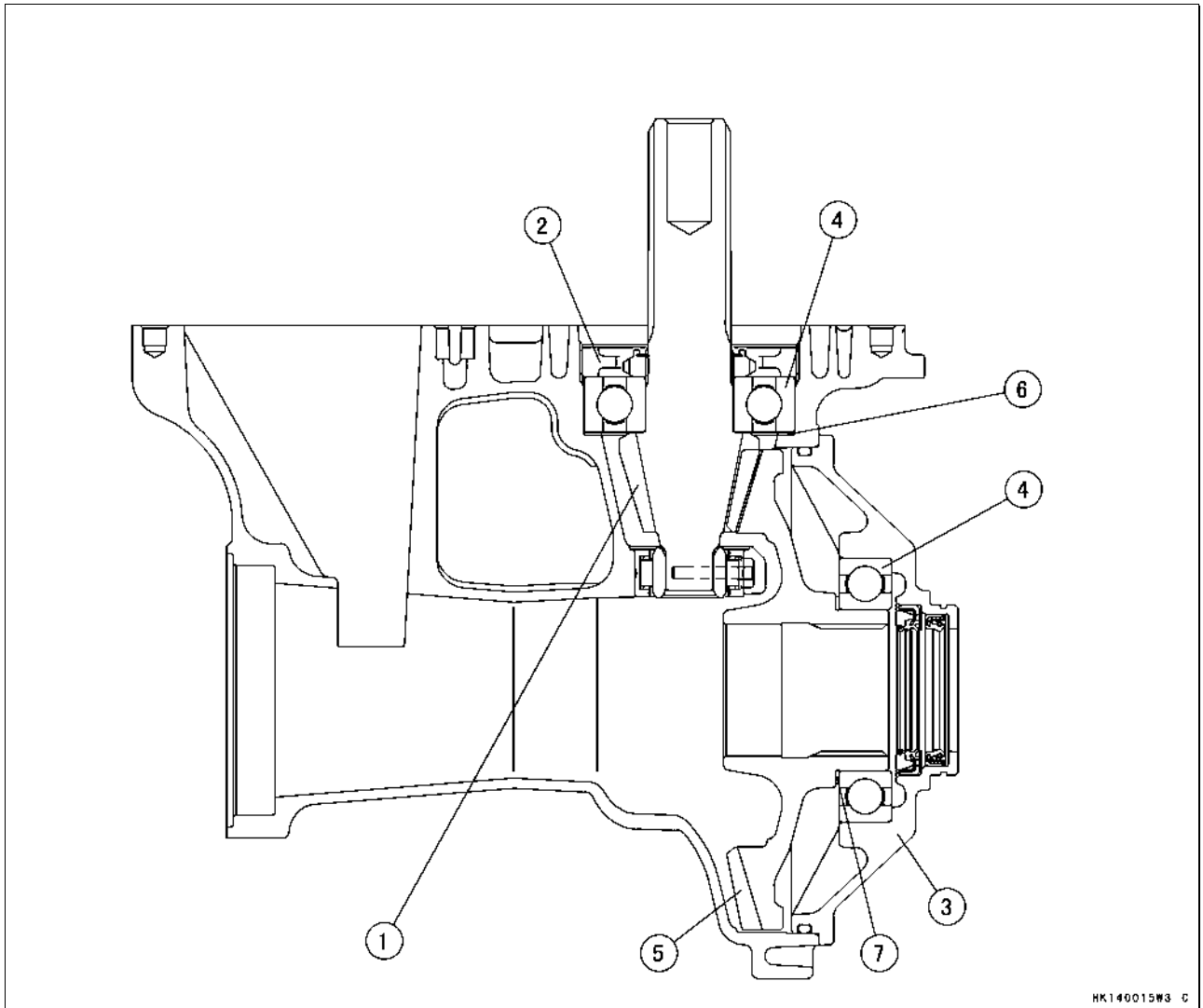

HK140015W3 C

1. Pinion Gear
2. Pinion Gear Bearing Holder
3. Gear Case Right Cover
4. Ball Bearings

5. Ring Gear
6. Pinion Gear Shim(s)
7. Ring Gear Shim(s)

11-50 FINAL DRIVE

Rear Final Gear Case

6. Pinion Gear Shims for Tooth Contact Adjustment

Thickness	Part Number
0.15 mm (0.006 in.)	92180-1320
0.2 mm (0.008 in.)	92180-1319
0.5 mm (0.020 in.)	92180-1321
0.8 mm (0.031 in.)	92180-1322
1.0 mm (0.039 in.)	92180-1345
1.2 mm (0.047 in.)	92180-1346

7. Ring Gear Shims for Backlash Adjustment

Thickness	Part Number
0.15 mm (0.006 in.)	92180-1318
0.2 mm (0.008 in.)	92180-1316
0.5 mm (0.020 in.)	92180-1317
0.8 mm (0.031 in.)	92180-1315
1.0 mm (0.039 in.)	92180-1343
1.2 mm (0.047 in.)	92180-1344

Backlash Adjustment

- Clean any dirt and oil off the bevel gear teeth.
- Install the pinion gear assembly with the primary shim **1.0 mm (0.039 in.) thickness**.
- Assemble the rear final gear case (see Rear Final Gear Case Assembly).
- Install the ring gear with the primary shim **1.0 mm (0.039 in.) thickness**.
- Check the backlash during tightening the cover bolts, and stop tightening them immediately if the backlash disappears. Then, change the ring gear shim to a thinner one.
- Temporarily, install the rear axle in the gear case and hold it with a vise so that the ring gear is lower than the pinion gear.
- Mount a dial gauge [A] so that the tip of the gauge is against the splined portion [B] of the pinion gear joint.
- To measure the backlash, move the pinion gear shaft back and forth [C] while holding the rear axle steady. The difference between the highest and the lowest gauge reading is the amount of backlash.
- Measure backlash at three locations equally spaced on the splines.

Rear Final Bevel Gear Backlash : 0.07 ~ 0.14 mm (0.003 ~ 0.006 in.) at pinion gear spline

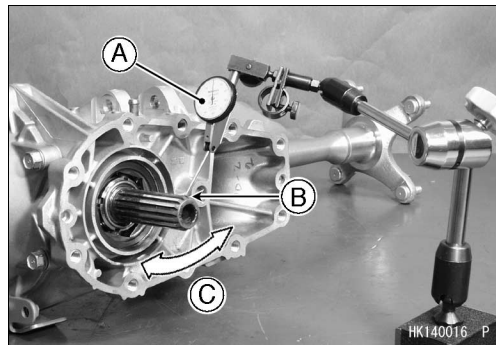

- ★ If the backlash is not within the limit, replace the ring gear shim(s). To increase backlash, decrease the thickness of the shim(s). To decrease backlash, increase the thickness of the shim(s).
- ★ Change the thickness a little at a time.
- Recheck the backlash, and readjust as necessary.

Tooth Contact Adjustment

- Clean any dirt and oil off the bevel gear teeth.
- Apply checking compound to 4 or 5 teeth of the pinion gear.

NOTE

- Apply checking compound to the teeth in a thin, even coat with a fairly stiff paint brush. If painted too thickly, the exact tooth pattern may not appear.
- The checking compound must be smooth and firm, with the consistency of tooth paste.
- Special compounds are available at automotive supply stores for the purpose of checking differential gear tooth patterns and contact.

Rear Final Gear Case

- Assemble the rear final gear case (see Rear Final Gear Case Assembly).
- Turn the pinion gear for one revolution in the drive and reverse (coast) direction, while creating drag on the ring gear.
- Remove the ring gear and pinion gear unit to check the drive pattern and coast pattern of the bevel gear teeth.
- The tooth contact patterns of both (drive and coast) sides should be centrally located between the top and bottom of the tooth. The drive pattern can be a little closer to the toe and the coast pattern can be a somewhat longer and closer to the toe.
- ★ If the tooth contact pattern is incorrect, replace the pinion gear shim(s), following the examples shown (see Correct Tooth Contact Pattern in the Front Final Bevel Gear Adjustment section).
- Then erase the tooth contact patterns, and check them again. Also check the backlash every time the shim(s) are replaced. Repeat the shim change procedure as necessary.

NOTE

- If the backlash is out of the standard range after changing the pinion gear shim(s), change the ring gear shim(s) to correct the backlash before checking the tooth contact pattern.

Pinion Gear Unit Disassembly

- Remove:
 - Pinion Gear Unit [A] (see Rear Final Gear Case Disassembly)
- Hold the pinion gear bearing holder nut [B] with the socket wrench [C] in a vise, and loosen the pinion gear shaft using the pinion gear holder [D].

Special Tools - Socket Wrench: 57001-1363
Pinion Gear Holder: 57001-1480

- Remove the ball bearing [E] as necessary.

Special Tool - Bearing Puller: 57001-135

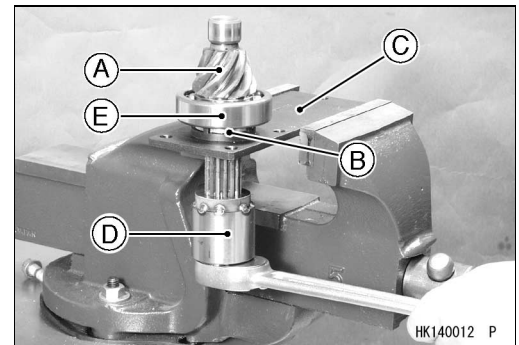

Pinion Gear Unit Assembly

- The pinion gear and ring gear are lapped as a set in the factory to get the best tooth contact. They must be replaced as a set.
- Visually inspect the bearing for abrasion, color change, or other damage.
- ★ If there is any doubt as to the condition of a bearing, replace the bearing.
- Be sure to check and adjust the bevel gear backlash and tooth contact, when any of the backlash-related parts are replaced (see Front Final Bevel Gear Adjustment).
- Press the bearing [A] on the pinion gear until it is bottomed.
- Install the pinion gear bearing holder nut [B] so that the projection [C] faces outward.

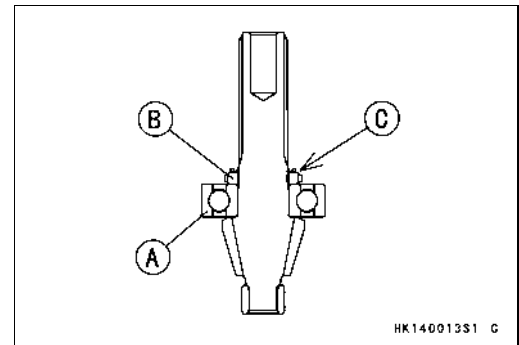

- Apply a non-permanent locking agent to the pinion gear bearing holder nut [A], and tighten it.

Special Tools - Socket Wrench [B]: 57001-1363
Pinion Gear Holder [C]: 57001-1480

Torque - Pinion Gear Bearing Holder Nut: 157 N·m (16 kgf·m, 116 ft·lb)

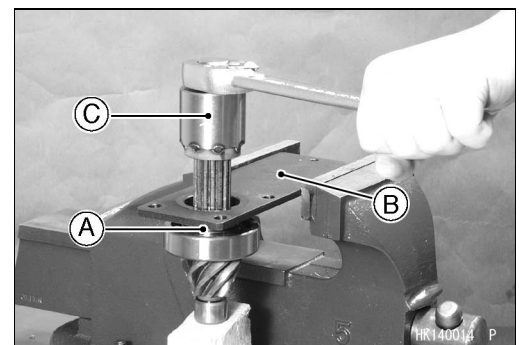

11-52 FINAL DRIVE

Rear Final Gear Case

Bevel Gear Inspection

- Visually check the bevel gears [A] for scoring, chipping, or other damage.
- ★ Replace the bevel gears as a set if either gear is damaged.

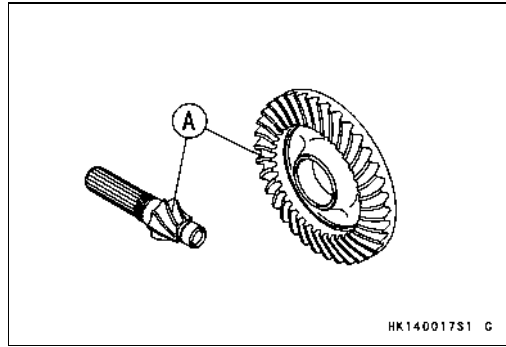

Bearing and Oil Seal

Ball or Needle Bearing Inspection

Since the bearings are made to extremely close tolerances, the clearance cannot normally be measured.

CAUTION

Do not remove any bearings for inspection except the right rear axle bearing.

- Turn each bearing in the case or hub back and forth [A] while checking for plays, roughness, or binding.
- ★ If bearing play, roughness, or binding is found, replace the bearing.

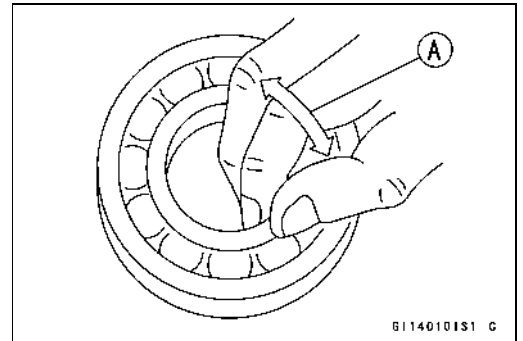

- Check the needle bearings [A] in the rear final gear case.
- The rollers in the needle bearing normally wear very little, and wear is difficult to measure. Instead of measuring, inspect the bearing for abrasion, color change, or other damage.
- ★ If the bearing is damaged, replace the rear final gear case.

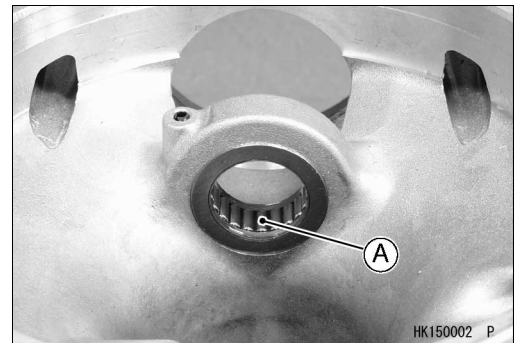

11-54 FINAL DRIVE

Bearing and Oil Seal

Oil Seal Inspection

- Inspect the oil seals [A].
- ★ Replace any if the lips are misshapen, discolored (indicating that the rubber has deteriorated), hardened, or been otherwise damaged.

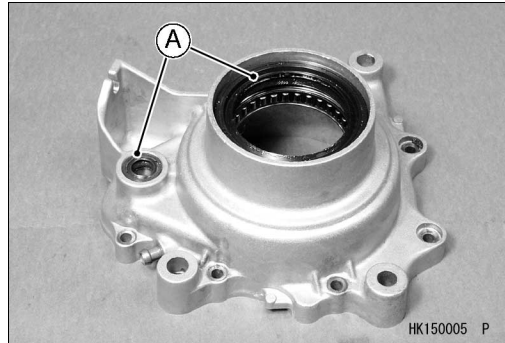
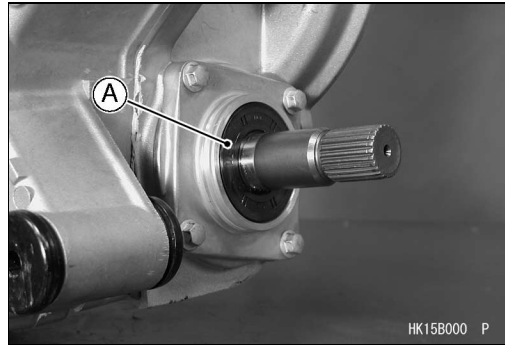

Brakes

Table of Contents

Exploded View.....	12-2	Brake Pad Wear Inspection.....	12-15
Specifications.....	12-6	Brake Discs.....	12-16
Brake Fluid.....	12-7	Disc Cleaning.....	12-16
Brake Fluid Recommendation.....	12-7	Disc Removal.....	12-16
Brake Fluid Level Inspection.....	12-8	Disc Installation.....	12-16
Brake Fluid Change.....	12-8	Disc Wear.....	12-16
Brake Line Air Bleeding.....	12-8	Disc Runout.....	12-16
Master Cylinder.....	12-9	Brake Hoses.....	12-17
Master Cylinder Removal.....	12-9	Brake Hose Inspection.....	12-17
Master Cylinder Installation.....	12-9	Brake Hose Replacement.....	12-17
Master Cylinder Disassembly.....	12-9	Rear Brake Lever, Pedal and Cables.....	12-18
Master Cylinder Assembly.....	12-10	Brake Pedal Position Inspection.....	12-18
Master Cylinder Inspection (Visual Inspection).....	12-10	Brake Pedal Position Adjustment.....	12-18
Calipers.....	12-11	Rear Brake Lever Free Play Inspection.....	12-18
Caliper Removal.....	12-11	Brake Pedal Free Play Inspection.....	12-18
Caliper Installation.....	12-11	Rear Brake Lever and Pedal Free Play Adjust- ment.....	12-18
Caliper Disassembly.....	12-11	Brake Pedal Removal.....	12-18
Caliper Assembly.....	12-13	Brake Pedal Installation.....	12-18
Fluid Seal Damage.....	12-13	Brake Cable Removal.....	12-19
Dust Seal and Friction Boot Damage.....	12-14	Brake Cable Installation.....	12-19
Piston and Cylinder Damage.....	12-14	Brake Cable Lubrication.....	12-19
Caliper Holder Shaft Wear Inspection.....	12-14	Internal Wet Brake.....	12-20
Brake Pads.....	12-15	Internal Wet Brake Disassembly.....	12-20
Brake Pad Removal.....	12-15	Internal Wet Brake Assembly.....	12-21
Brake Pad Installation.....	12-15		

12-2 BRAKES

Exploded View

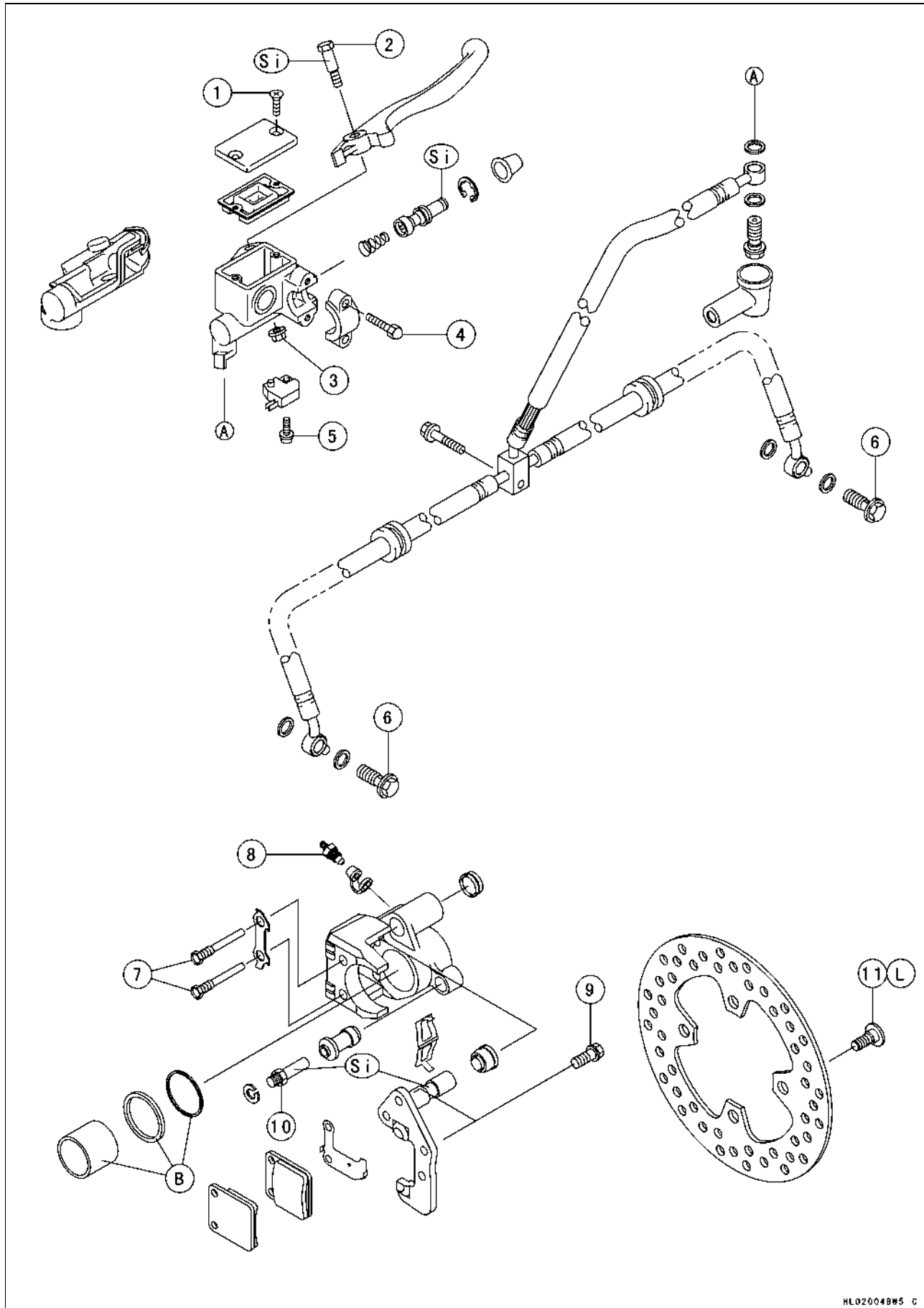

Exploded View

No.	Fastener	Torque			Remarks
		N·m	kgf·m	ft·lb	
1	Reservoir Cap Screws	1.5	0.15	13 in·lb	
2	Brake Lever Pivot Bolt	5.9	0.6	52 in·lb	
3	Brake Lever Pivot Bolt Locknut	5.9	0.6	52 in·lb	
4	Master Cylinder Clamp Bolts	8.8	0.9	78 in·lb	
5	Brake Switch Mounting Bolt	1.2	0.12	10 in·lb	
6	Brake Hose Banjo Bolts	25	2.5	18	
7	Pad Mounting Bolts	18	1.8	13	
8	Bleed Valves	5.9	0.6	52 in·lb	
9	Caliper Mounting Bolts	25	2.5	18	
10	Caliper Holder Shaft	18	1.8	13	
11	Disc Mounting Bolts	37	3.8	27	L

B: Apply brake fluid.

L: Apply a non-permanent locking agent.

Si: Apply silicone grease.

12-4 BRAKES

Exploded View

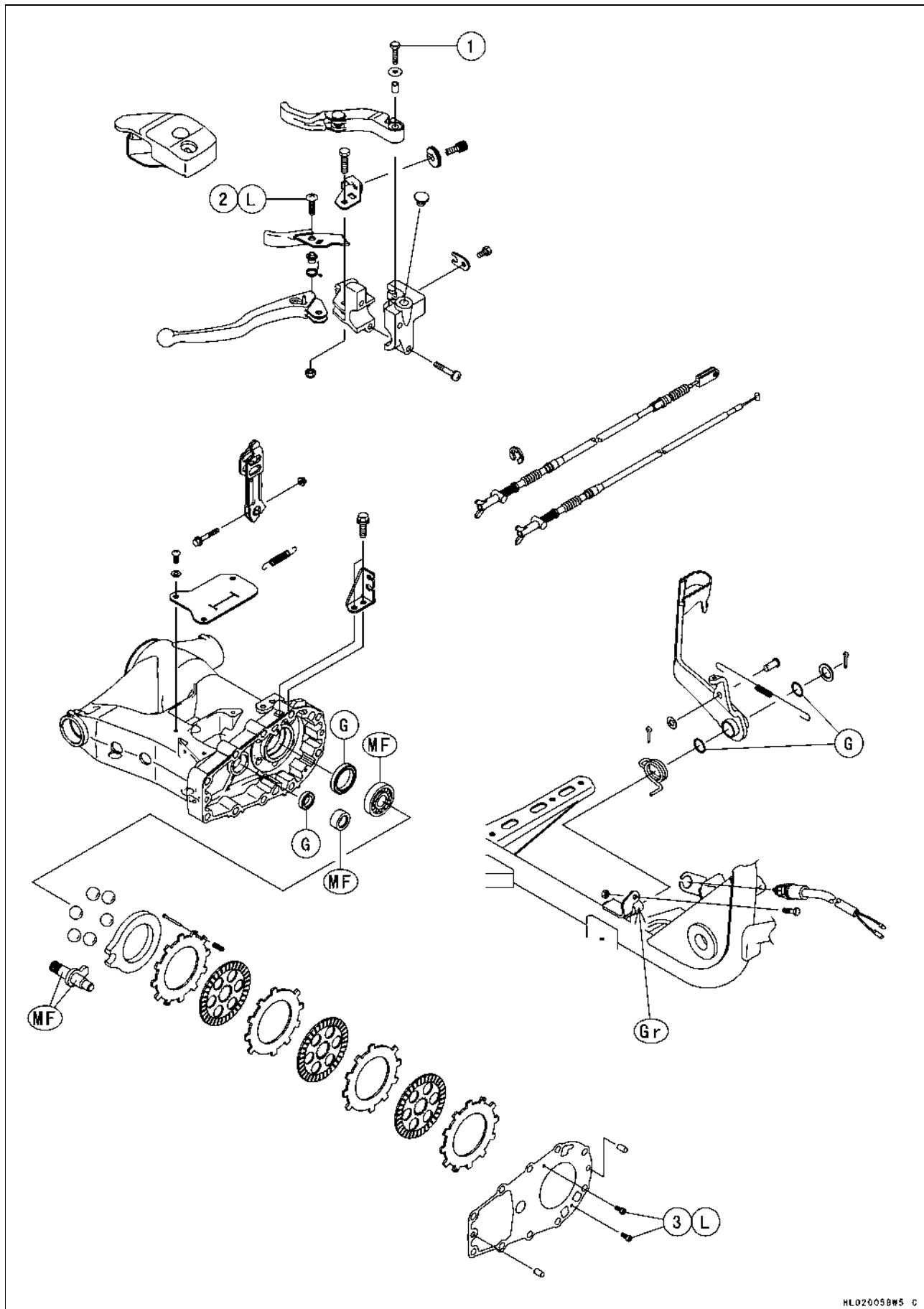

Exploded View

No.	Fastener	Torque			Remarks
		N·m	kgf·m	ft·lb	
1	Variable Differential Control Lever Bolt	3.5	0.36	31 in·lb	
2	Parking Brake Lever Screw	2.2	0.22	19 in·lb	L
3	Gasket Screws	–	–	–	L

G: Apply grease for oil seal and O-ring.

L: Apply a non-permanent locking agent.

Gr: Apply grease.

MF: Apply MOBIL FLUID 424 or equivalent oil.

12-6 BRAKES

Specifications

Item	Standard	Service Limit
Brake Fluid: Type	DOT 3 or DOT 4	---
Front Disc Brake: Pad lining thickness Disc thickness Disc runout	4.5 mm (0.18 in.) 3.3 ~ 3.7 mm (0.130 ~ 0.146 in.) TIR 0.2 mm (0.008 in.) or less	1 mm (0.04 in.) 3 mm (0.12 in.) TIR 0.3 mm (0.012 in.)
Rear Brake Lever, Pedal and Cables: Rear brake pedal position Rear brake lever free play Rear brake pedal free play	60 ~ 65 mm (2.36 ~ 2.56 in.) above footboard 1 ~ 2 mm (0.04 ~ 0.08 in.) 15 ~ 25 mm (0.6 ~ 1.0 in.)	--- --- ---

Special Tool - Inside Circlip Pullers: 57001-143

Brake Fluid

⚠ WARNING

When working with the disc brake, observe the precautions listed below.

1. Never reuse old brake fluid.
2. Do not use fluid from a container that has been left unsealed or that has been open for a long time.
3. Do not mix two types and brands of fluid for use in the brake. This lowers the brake fluid boiling point and could cause the brake to be ineffective. It may also cause the rubber brake parts to deteriorate.
4. Don't leave the reservoir cap off for any length of time to avoid moisture contamination of the fluid.
5. Don't change the fluid in the rain or when a strong wind is blowing.
6. Except for the disc pads and disc, use only disc brake fluid, isopropyl alcohol, or ethyl alcohol for cleaning brake parts. Do not use any other fluid for cleaning these parts. Gasoline, engine oil, or any other petroleum distillate will cause deterioration of the rubber parts. Oil spilled on any part will be difficult to wash off completely and will eventually deteriorate the rubber used in the disc brake.
7. When handling the disc pads or disc, be careful that no disc brake fluid or any oil gets on them. Clean off any fluid or oil that inadvertently gets on the pads or disc with a high flash-point solvent. Do not use one which will leave an oily residue. Replace the pads with new ones if they cannot be cleaned satisfactorily.
8. Brake fluid quickly ruins painted surfaces; any spilled fluid should be completely washed away immediately.
9. If any of the brake line fittings or the bleed valve is opened at any time, the **AIR MUST BE BLED FROM THE BRAKE LINE.**

Brake Fluid Recommendation

Use extra heavy-duty brake fluid only from a container marked DOT3 or DOT4.

Recommended Disc Brake Fluid

Type : DOT 3 or DOT 4

12-8 BRAKES

Brake Fluid

Brake Fluid Level Inspection

- Refer to Brake Fluid Level Inspection in Periodic Maintenance chapter.

Brake Fluid Change

- Refer to Brake Fluid Change in Periodic Maintenance chapter.

Brake Line Air Bleeding

- Remove the front wheels (see Wheels/Tires chapter).
- Bleed the air whenever brake parts are replaced or reassembled.
- Remove the reservoir cap and fill the reservoir with new brake fluid.
- Slowly pump the brake lever several times until no air bubbles can be seen rising up through the fluid from the hose at the bottom of the reservoir. This bleeds the air from the master cylinder and the brake line.

NOTE

- Tap the brake hose lightly going from the caliper to the reservoir side and bleed the air off at the reservoir.
- Attach a clear plastic hose to the bleed valve on the caliper, and run the other end of the hose into a container.
- Bleed the brake line and the caliper as follows:
 - Hold the brake lever applied [A].
 - Quickly open and close the valve [B].
 - Release the brake lever [C].
- The fluid level must be checked several times during the bleeding operation and replenished as necessary.

NOTE

- If the fluid in the reservoir runs completely out any time during bleeding, the bleeding operation must be done over again from the beginning since air will have entered the line.
- If the brake lever action still feels soft or "spongy", tap the brake hose from bottom to top and air will rise up to the top part of the hose. Slowly pump the brake lever in the same manner as above.
- Tighten:
 - Torque - Bleed Valves : 5.9 N·m (0.6 kgf·m, 52 in·lb)**
- Install the front wheels (see Wheels/Tires chapter).
- Apply the brake lever forcefully for a few seconds, and check for fluid leakage around the fittings.

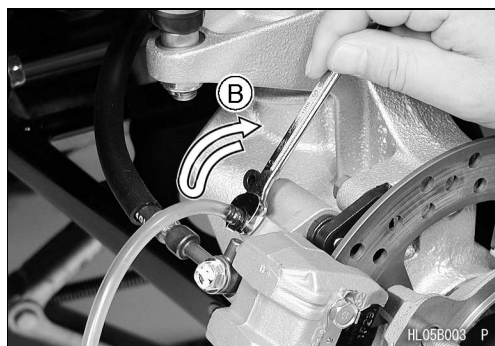
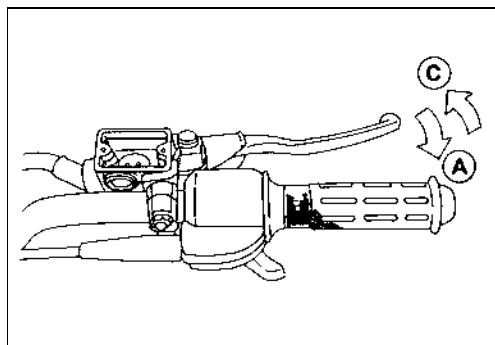

Master Cylinder

Master Cylinder Removal

- Remove:
 - Brake Hose Banjo Bolt [A]
 - Master Cylinder Clamp Bolts [B]
 - Master Cylinder [C]

CAUTION

Brake fluid quickly ruins painted surface; any spilled fluid should be completely washed away immediately.

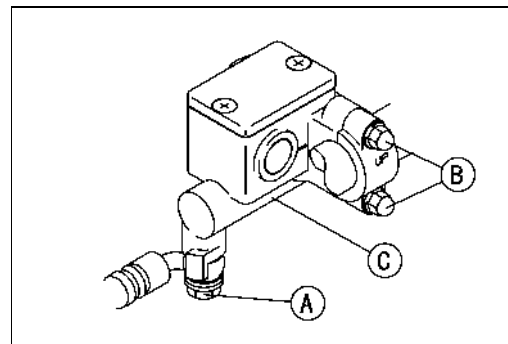

Master Cylinder Installation

- The master cylinder clamp must be installed with the "UP" mark [A] upwards.
- Tighten the upper clamp bolt first, and then the lower clamp bolt. There will be a gap at the lower part of the clamp after tightening.
- Torque - Master Cylinder Clamp Bolts: 8.8 N·m (0.9 kgf·m, 78 in·lb)**
- Use a new flat washer on each side of the brake hose fitting, and tighten the banjo bolt.
- Torque - Brake Hose Banjo Bolt: 25 N·m (2.5 kgf·m, 18 ft·lb)**
- Bleed the brake line after master cylinder installation (see Brake Line Air Bleeding).
- Check the brake for good braking power, no braking brag, and no fluid leakage.

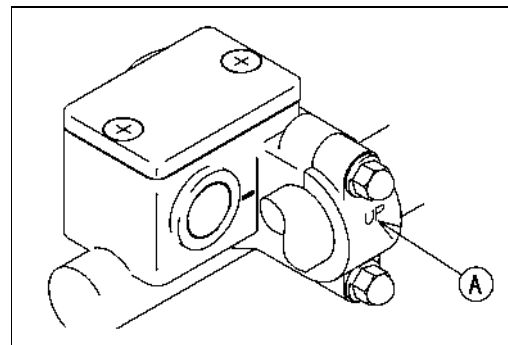

WARNING

Do not attempt to drive the vehicle until a firm brake lever can be obtained by pumping the brake lever until the pads are against each disc. The brakes will not function on the first application of the lever if this is not done.

Master Cylinder Disassembly

- Remove:
 - Master Cylinder (see Master Cylinder Removal)
 - Brake Lever Pivot Nut [A]
 - Brake Lever Pivot Bolt [B]
 - Brake Lever [C]
 - Dust Cover [D]
 - Circlip [E]
 - Piston [F]
 - Spring [G]

Special Tool - Inside Circlip Pliers: 57001-143

CAUTION

Do not remove the secondary cup [H] from the piston since removal will damage it.

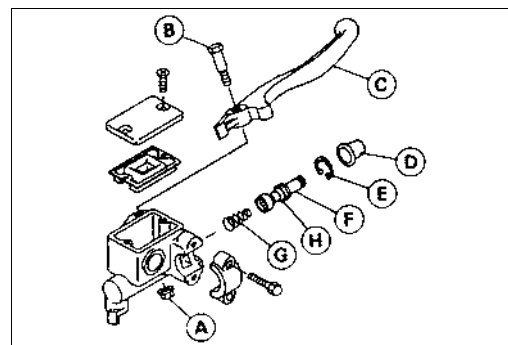

12-10 BRAKES

Master Cylinder

Master Cylinder Assembly

- Before assembly, clean all parts including the master cylinder with brake fluid or alcohol.

CAUTION

Except for the disc pads and disc, use only disc brake fluid, isopropyl alcohol, or ethyl alcohol for cleaning brake parts. Do not use any other fluid for cleaning these parts. Gasoline, engine oil, or any other petroleum distillate will cause deterioration of the rubber parts. Oil spilled on any part will be difficult to wash off completely, and will eventually deteriorate the rubber used in the disc brake.

- Take care not to scratch the piston or the inner wall of the cylinder.
- Apply brake fluid to the removed parts and to the inner wall of the cylinder.
- Tighten:
 - Torque - Brake Lever Pivot Bolt: 5.9 N·m (0.6 kgf·m, 52 in·lb)
 - Brake Lever Pivot Bolt Locknut: 5.9 N·m (0.6 kgf·m, 52 in·lb)

Master Cylinder Inspection (Visual Inspection)

- Disassemble the master cylinder (see Master Cylinder Disassembly).
- Check that there are no scratches, rust or pitting on the inner wall of the master cylinder [A] and on the outside of the piston [B].
- ★ If the master cylinder or piston shows any damage, replace them.
- Inspect the primary [C] and secondary [D] cups.
- ★ If a cup is worn, damaged, softened (rotted), or swollen, the piston assembly should be replaced to renew the cups.
- ★ If fluid leakage is noted at the brake lever, the piston assembly should be replaced to renew the cups.
- Check the dust cover [E] for damage.
- ★ If it is damaged, replace it.
- Check that the relief [F] and supply [G] ports are not plugged.
- ★ If the relief port becomes plugged, the brake pads will drag on the disc. Blow the ports clean with compressed air.
- Check the piston return spring [H] for any damage.
- ★ If the spring is damaged, replace it.

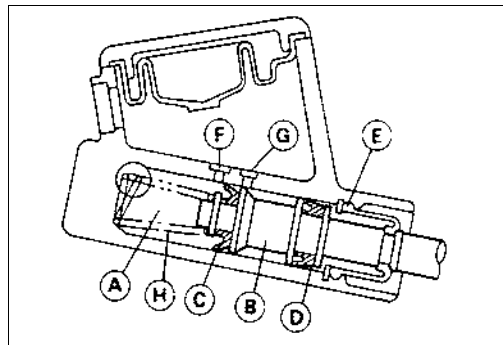

Calipers

Caliper Removal

- Remove the front wheel (see Wheels/Tires chapter).
- Loosen the banjo bolt [A] at the brake hose lower end, and tighten it loosely.
- Unscrew the caliper mounting bolts [B] with a socket wrench and an extension bar.
- Detach the caliper [C] from the disc.
- Unscrew the banjo bolt and remove the brake hose [D] from the caliper.

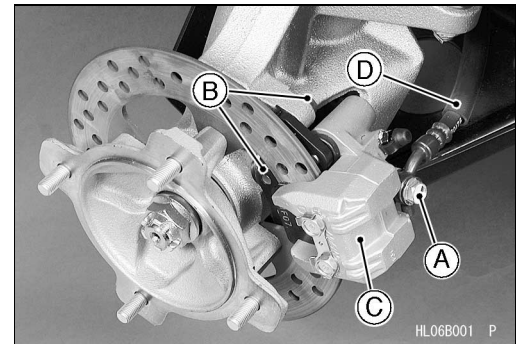

CAUTION

Immediately wash away any brake fluid that spills.

NOTE

- If the caliper is to be disassembled after removal and if compressed air is not available, disassemble the caliper before the brake hose is removed (see Caliper Disassembly).

Caliper Installation

- Install the caliper and brake hose lower end.
- Replace the washers that are on each side of hose fitting with new ones.
- Tighten:
 - Torque - Caliper Mounting Bolts: 25 N·m (2.5 kgf·m, 18 ft·lb)
 - Brake Hose Banjo Bolt: 25 N·m (2.5 kgf·m, 18 ft·lb)
- Check the fluid level in the brake reservoir.
- Bleed the brake line (see Brake Line Air Bleeding).
- Check the brake for good braking power, no brake drag, and no fluid leakage.

WARNING

Do not attempt to drive the vehicle until a firm brake lever can be obtained by pumping the brake lever until the pads are against each disc. The brakes will not function on the first application of the lever if this is not done.

Caliper Disassembly

- Remove:
 - Caliper (see Caliper Removal)
 - Pads (see Brake Pad Removal)
 - Anti-rattle Spring
- Using compressed air, remove the piston.
 - Cover the caliper opening with a clean, heavy cloth [A].
 - Remove the piston by lightly applying compressed air [B] to where the brake line fits into the caliper.

WARNING

To avoid serious injury, never place your fingers or palm inside the caliper opening. If you apply compressed air into the caliper, the piston may crush your hand or fingers.

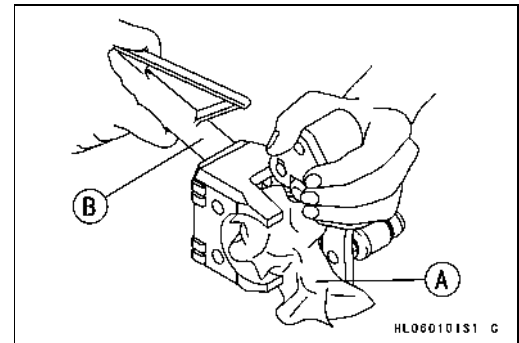

NOTE

- If compressed air is not available, do as follows with the brake hose connected to the caliper.
- Prepare a container for brake fluid.
- Remove the pads and spring (see Brake Pad Removal).
- Pump the brake lever to remove the caliper piston.

12-12 BRAKES

Calipers

- Remove:
Plug [A]

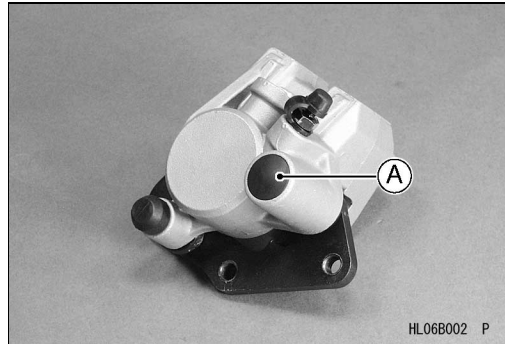

- Loosen:
Caliper Holder Shaft (Allen Bolt) [A]

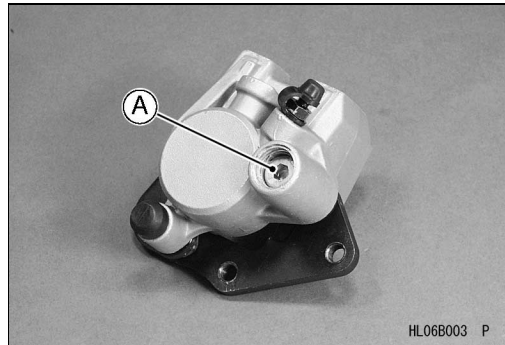

- Remove:
Washer [A] and Caliper Holder shaft [B]
Caliper Holder [C]
Boots [D]

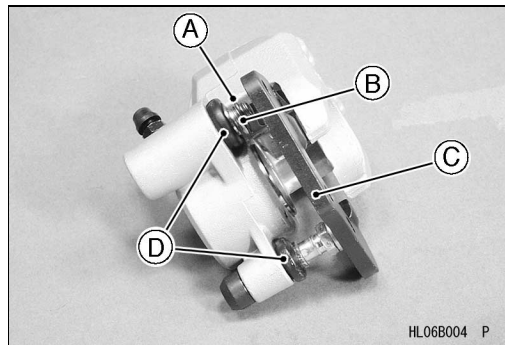

- Remove:
Dust Seal [A]
Fluid Seal [B]

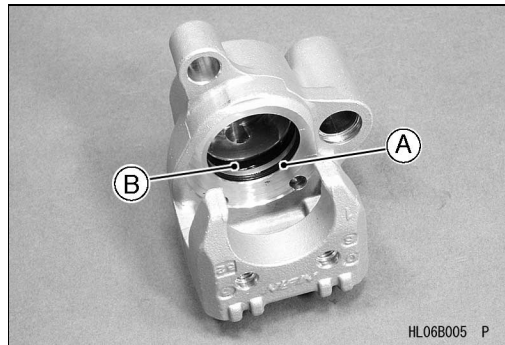

- Remove:
Caliper Holder Shaft [A]
Washer [B]
Caliper Holder [C]

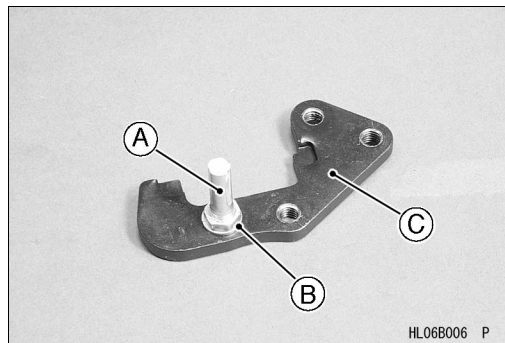

Calipers

Caliper Assembly

- Replace the fluid seal [A] with a new one.
- Apply brake fluid to the fluid seal, and install it into the cylinder by hand.
- Replace the dust seal [B] with a new one if it is damaged.
- Apply brake fluid to the dust seal, and install it into the cylinder by hand.

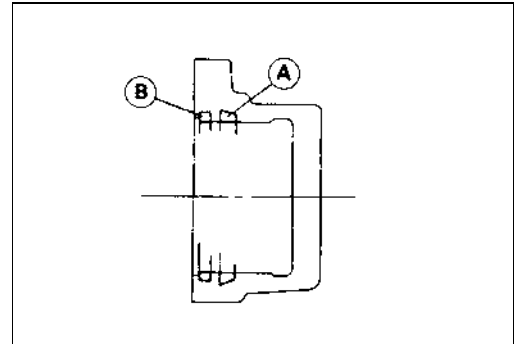

- Install the anti-rattle spring [A] in the caliper as shown.

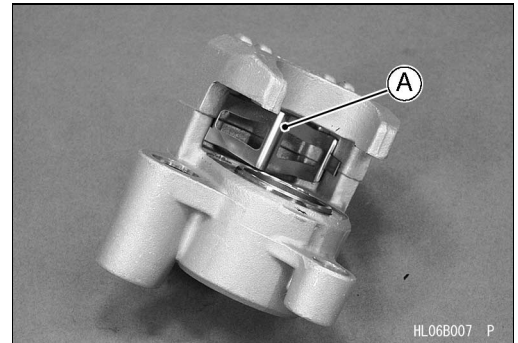

- Apply brake fluid to the outside of the piston [A], and push it into the cylinder by hand. Take care that neither the cylinder nor the piston skirt gets scratched.
- Replace the rubber boots [B] and plug [C] if they are damaged.
- Apply a thin coat of silicone grease to the caliper holder shafts [D] and holder holes [E] (Silicone grease is a special high temperature, water-resistant grease).

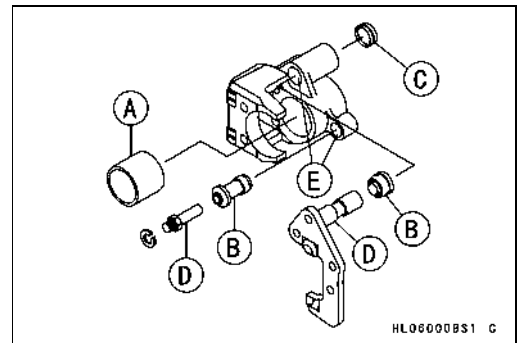

- Install the caliper holder plate [A].
Torque - Caliper Holder Shaft: 18 N·m (1.8 kgf·m, 13 ft·lb)
- Install the bleed valve and rubber cap.
Torque - Bleed Valve: 5.9 N·m (0.6 kgf·m, 52 in·lb)
- Install the pads (see Brake Pad Installation).

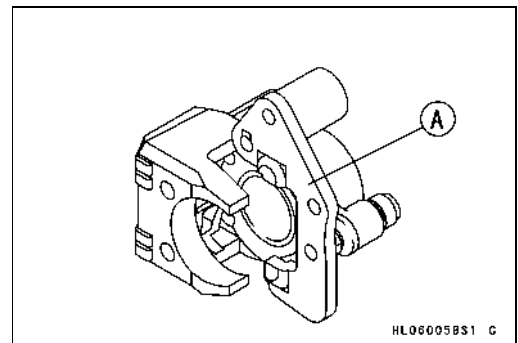

Fluid Seal Damage

The fluid seals [A] around the piston maintain the proper pad/disc clearance. If the seals are not satisfactory, pad wear will increase, and constant pad drag on the disc will raise brake and brake fluid temperature.

- Replace the fluid seals under any of the following conditions: (a) fluid leakage around the pad; (b) brakes overheat; (c) there is a large difference in inner and outer pad wear; (d) the seal is stuck to the piston.
- ★ If the fluid seal is replaced, replace the dust seal as well. Also, replace all seals every other time the pads are changed.

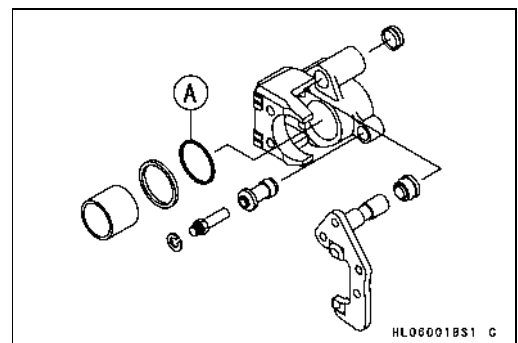

12-14 BRAKES

Calipers

Dust Seal and Friction Boot Damage

- Check that the dust seals [A] and friction boots [B] are not cracked, worn swollen, or otherwise damaged.
- ★ If they show any damage, replace them.

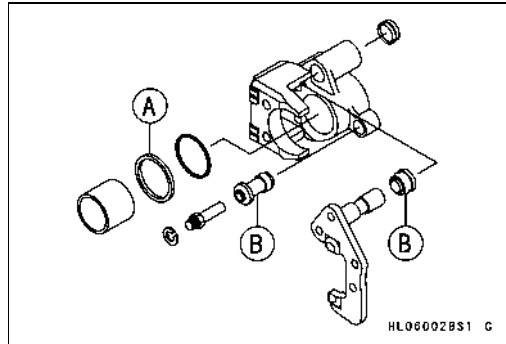

Piston and Cylinder Damage

- Visually inspect the piston [A] and cylinder surfaces.
- ★ Replace the caliper if the cylinder and piston are badly scored or rusty.

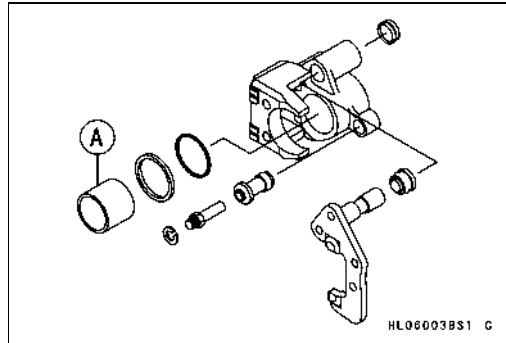

Caliper Holder Shaft Wear Inspection

The caliper body must slide smoothly on the caliper holder shafts [A]. If the body does not slide smoothly, one pad will wear more than the other, pad wear will increase, and constant drag on the disc will raise brake and brake fluid temperature.

- Check to see that the caliper holder shafts are not badly worn or stepped, and that the rubber friction boots are not damaged.
- ★ If the rubber friction boot is damaged, replace the rubber friction boot.
- ★ If caliper holder shaft is damaged, replace the caliper holder shaft and rubber friction boot as a unit.

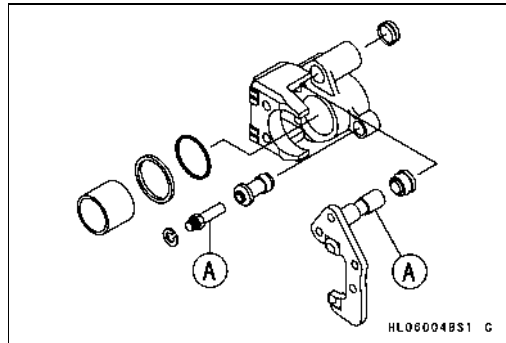

Brake Pads

Brake Pad Removal

- Remove the front wheel (see Wheels/Tires chapter).
- Flatten out the bended parts of the lockwasher [A].
- Loosen the pad mounting bolts [B].
- Lift off the caliper by taking off the caliper mounting bolts with the hose left attached.
- Remove:
 - Pad Mounting Bolts
 - Pads

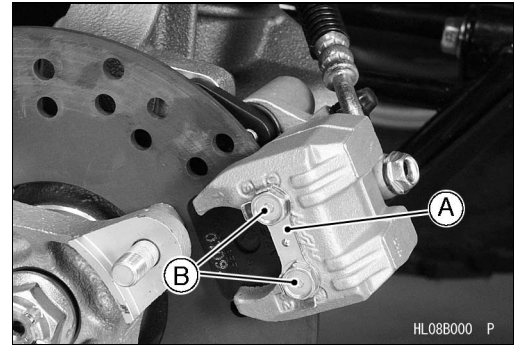

Brake Pad Installation

- Push the caliper piston in by hand as far as it will go.
- Be sure that the anti-rattle spring is in place.
- Install the pads.
 - The inboard pad [A] next to the piston has a wear protecting shim [B]. Be careful not mix it up with the outboard pad.
- Tighten:

Torque - Pad Mounting Bolts: 18 N·m (1.8 kgf·m, 13 ft·lb)

⚠ WARNING

Do not attempt to drive the vehicle until a full brake lever is obtained by pumping the brake lever until the pads are against each disc. The brake will not function on the first application if this is not done.

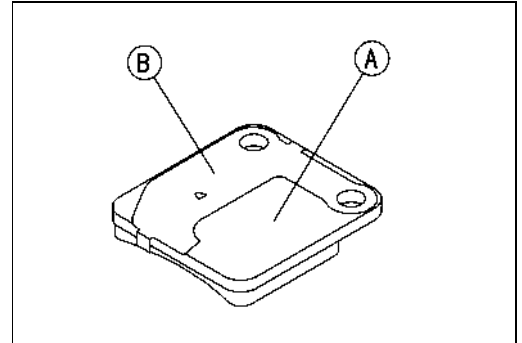

Brake Pad Wear Inspection

- Refer to Front Brake Pad Wear Inspection in Periodic Maintenance chapter.

12-16 BRAKES

Brake Discs

Disc Cleaning

Poor braking can be caused by oil on a disc. Oil on a disc must be cleaned off with an oilless cleaning fluid such as trichloroethylene or acetone.

⚠ WARNING

These cleaning fluids are usually highly flammable and harmful if breathed for prolonged periods. Be sure to heed the fluid manufacturer's warnings.

Disc Removal

- Remove:
 - Front Hub (see Wheels/Tires chapter)
 - Brake Disc Mounting Bolts [A]
 - Brake Disc [B]

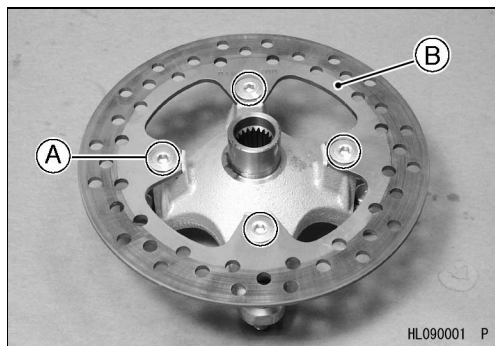

Disc Installation

- The disc must be installed with the marked side [A] facing toward the steering knuckle.
- Apply a non-permanent locking agent:
 - Disc Mounting Bolts
- Tighten:
 - Torque - Disc Mounting Bolts: 37 N·m (3.8 kgf·m, 27 ft·lb)**
- After installing the discs, check the disc runout. Completely clean off any grease that has gotten on either side of the disc with a high flash-point solvent. Do not use one which will leave an oily residue.

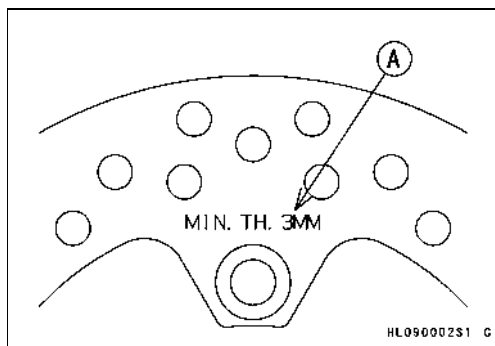

Disc Wear

- Measure the thickness of each disc at the point [A] where it has worn the most.
- ★ Replace the disc if it has worn past the service limit.

Disc Thickness

Standard:	3.3 ~ 3.7 mm (0.130 ~ 0.146 in.)
Service Limit:	3 mm (0.12 in.)

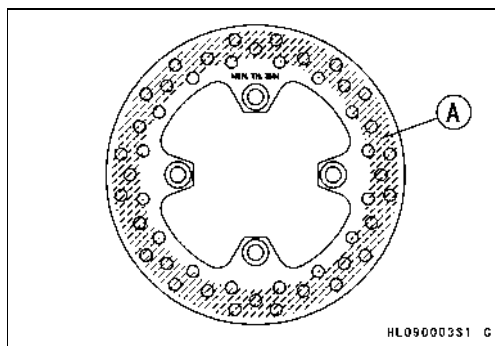

Disc Runout

- Jack up the vehicle so that the wheels are off the ground.
- Remove the front wheels and turn the handlebar fully to one side.
- Set up a dial gauge against the disc [A], and measure the disc runout.
- ★ If the runout exceeds the service limit, replace the disc.

Disc Runout

Standard:	TIR 0.2 mm (0.008 in.) or less
Service Limit:	TIR 0.3 mm (0.012 in.)

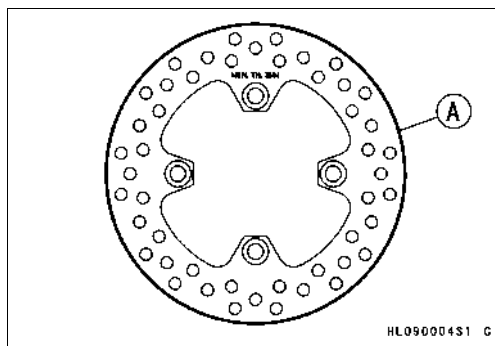

Brake Hoses

Brake Hose Inspection

- Refer to Brake Hose and Connection Check in Periodic Maintenance chapter.

Brake Hose Replacement

- Refer to Brake Hose Replacement in Periodic Maintenance chapter.

12-18 BRAKES

Rear Brake Lever, Pedal and Cables

Brake Pedal Position Inspection

- Check that the brake pedal [A] is in the correct position as shown.
[B] Footboard

Pedal Position [C]

Standard: 60 ~ 65 mm (2.36 ~ 2.56 in.) above footboard

- ★ If it is incorrect, adjust the brake pedal position.

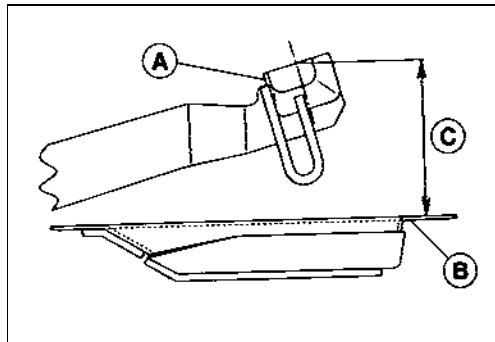

Brake Pedal Position Adjustment

- Loosen the locknut [A], and turn the adjusting bolt [B] until the brake pedal is correctly positioned.
- Tighten the locknut.
- Check the brake pedal free play (see Brake Pedal Free Play Inspection).

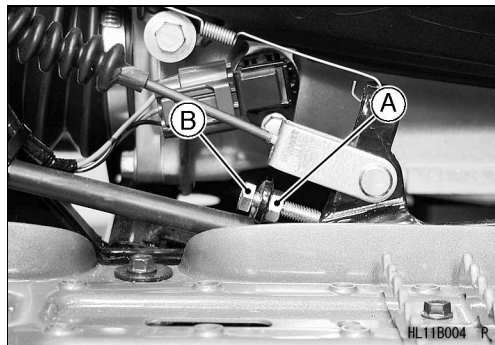

Rear Brake Lever Free Play Inspection

- Refer to Rear Brake Lever Free Play Inspection in Periodic Maintenance chapter.

Brake Pedal Free Play Inspection

- Refer to Brake Pedal Free Play Inspection in Periodic Maintenance chapter.

Rear Brake Lever and Pedal Free Play Adjustment

- Refer to Rear Brake Lever and Pedal Free Play Adjustment in Periodic Maintenance chapter.

Brake Pedal Removal

- Remove:
Right Footboard (see Frame chapter)
- Loosen the locknut and the adjusting bolt [A].
- Remove:
Brake Switch Spring [B]
Cotter Pin, Washer, Pin and Brake Cable Joint [C]
Cotter Pin and Washer [D]
O-ring and Brake Pedal [E]
Spring

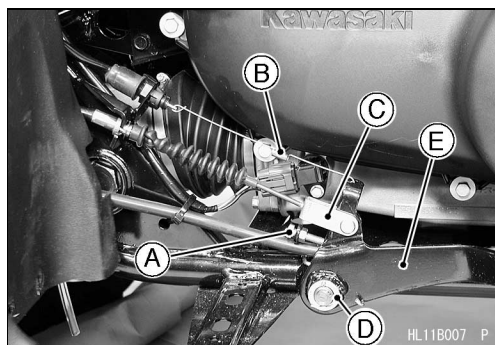

Brake Pedal Installation

- Apply grease:
Brake Pedal Pivot [A]
O-ring [B]

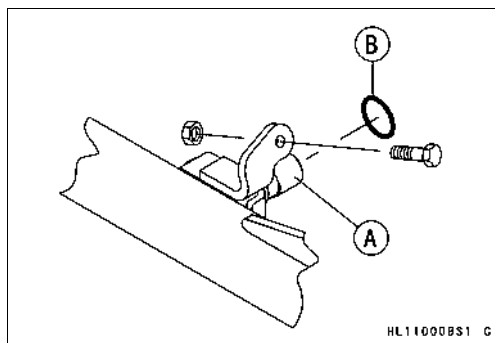

Rear Brake Lever, Pedal and Cables

- Install:
 - Spring [A]
 - Brake Pedal [B]
- Apply grease:
 - O-ring [C]
- Install:
 - Brake Cable Joint and Pin [D]
 - Brake Switch Spring [E]
 - Washers [F]
- Replace the cotter pins [G] with new ones.
- Adjust the brake pedal position (see Brake Pedal Position).

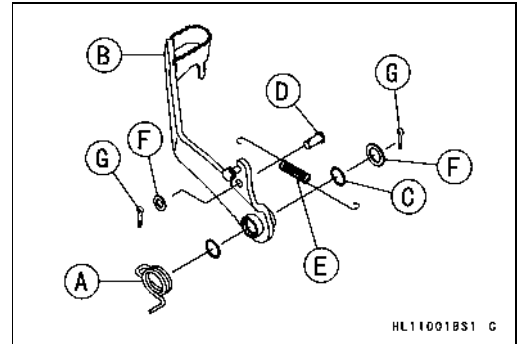

Brake Cable Removal

- Remove:
 - Right Rear Flap (see Frame chapter)
- Unscrew the adjusters [A] at the rear ends of the cables, and pull the cables out of the joints [B] and cable mounts [C].

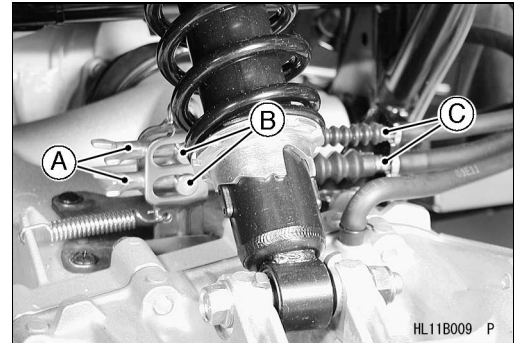

- Loosen the knurled locknut [A] at the rear brake lever and screw in the adjuster [B].
- Line up the slots [C] in the brake lever, knurled locknut, and adjuster, and then free the cable from the lever [D].
- Remove the brake lever cable from the frame.

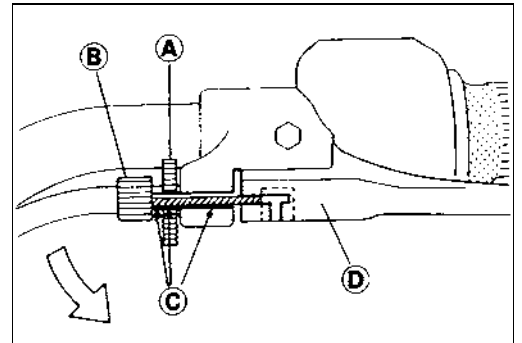

- Remove:
 - Circlip [A]
 - Cotter Pin, Washer and Pin [B]
 - Brake Pedal Cable [C]

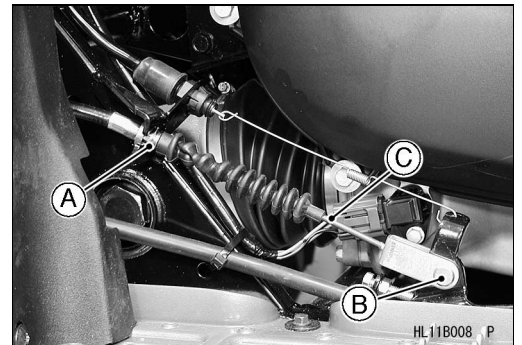

Brake Cable Installation

- Grease the brake cable front ends.
- Replace the cotter pin with a new one.
- Route the brake cables according to the Cable, Wire, and Hose Routing section in Appendix chapter.
- Adjust the brake pedal and rear brake lever.

Brake Cable Lubrication

- Whenever the brake cable is removed, lubricate the cable as follows:
 - Lubricate the cable with a penetrating rust inhibitor.

12-20 BRAKES

Internal Wet Brake

Internal Wet Brake Disassembly

- Remove:
 - Rear Final Gear Case (see Final Drive chapter)
 - Gasket Screws [A]
 - Gasket [B]
 - Dowel Pins [C]

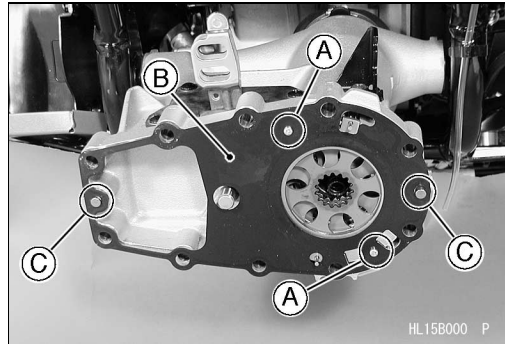

- Remove:
 - Steel Plates [A]
 - Friction Plates [B]
 - Pins [C] and Springs

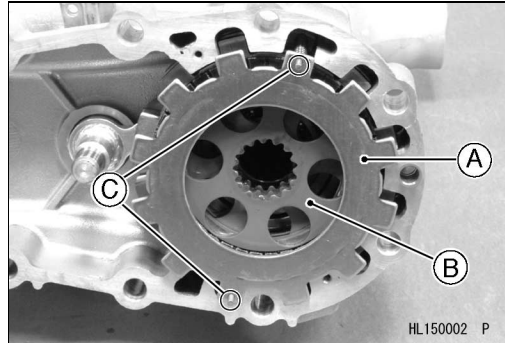

- Remove:
 - Cam Plate [A]

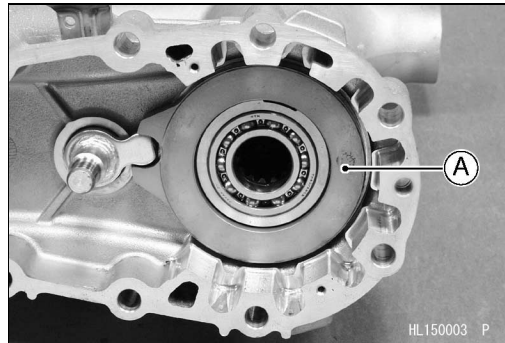

- Remove:
 - Steel Balls [A]

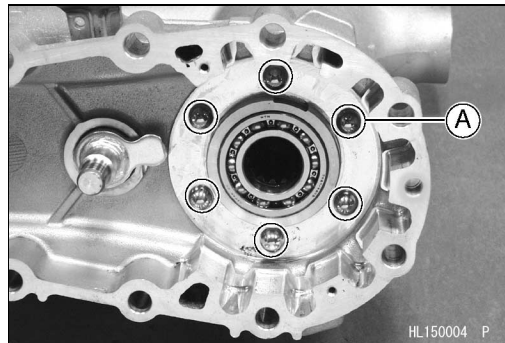

- Remove:
 - Brake Cam Lever Bolt and Nut [A]
 - Brake Camshaft [B]
 - Brake Cam Lever [C]

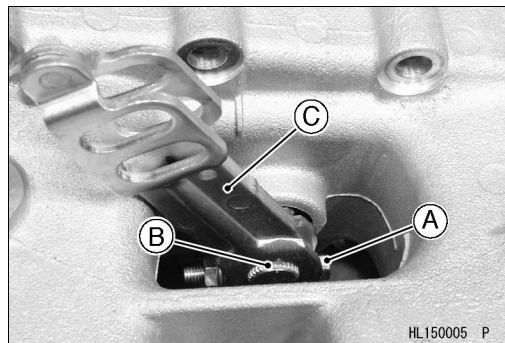

Internal Wet Brake

Internal Wet Brake Assembly

- Apply [A] MOBIL FLUID 424 or equivalent oil to the brake camshaft and the inside of the collar.
- Insert the camshaft in the swingarm.

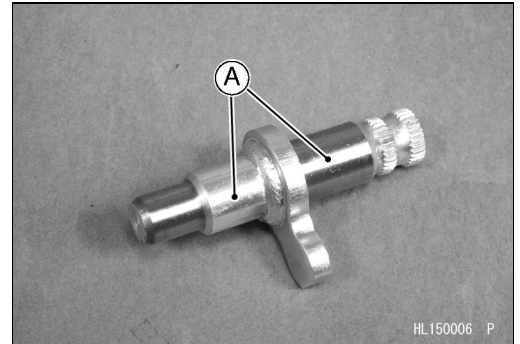

- Align the punch mark [A] on the brake cam lever with the punch mark [B] on the brake camshaft.

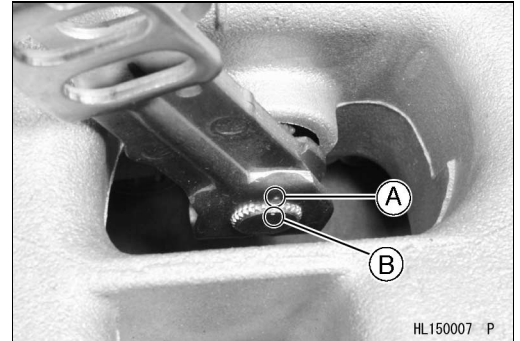

- Install:
 - Steel Balls
 - Brake Cam Plate [A]
- Fit the cam plate and brake camshaft [B] as shown.

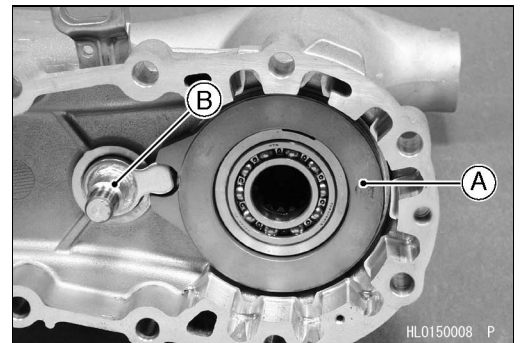

- Install:
 - Steel Pressure Plate [A] and Pins [B] (as shown)

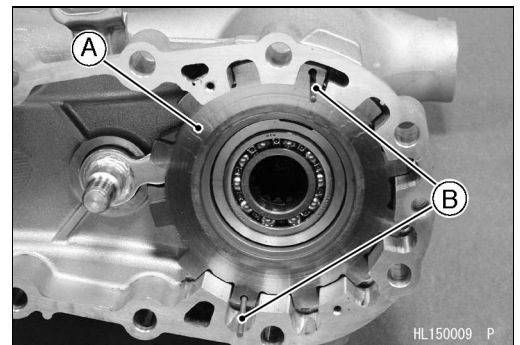

- Install:
 - Friction Plates [A]
 - Steel Plates [B]
 - Springs [C]
 - Steel Pressure Plate [D]

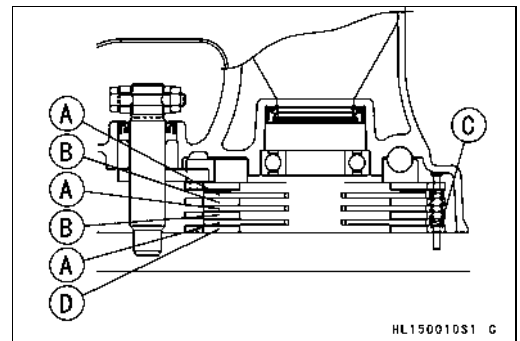

12-22 BRAKES

Internal Wet Brake

- Install:
 - Dowel Pins [A]
 - New Gasket [B]
- Apply a non-permanent locking agent to the gasket screws [C], and tighten them.
- Install:
 - Rear Final Gear Case (see Final Drive chapter)

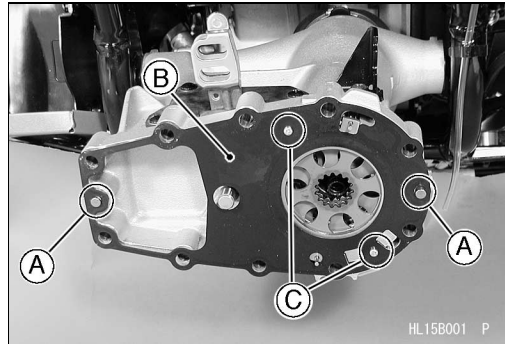

Suspension

Table of Contents

- Exploded View..... 13-2
- Specifications..... 13-4
- Shock Absorbers..... 13-5
 - Front Shock Absorber Removal..... 13-5
 - Front Shock Absorber Installation..... 13-5
 - Front Shock Absorber Inspection..... 13-5
 - Front Shock Absorber Spring Removal..... 13-6
 - Front Shock Absorber Spring Installation..... 13-7
 - Rear Shock Absorber Preload Adjustment..... 13-8
 - Rear Shock Absorber Removal..... 13-8
 - Rear Shock Absorber Installation..... 13-8
 - Rear Shock Absorber Inspection..... 13-9
 - Rear Shock Absorber Spring Removal..... 13-9
 - Rear Shock Absorber Spring Installation..... 13-10
 - Rear Shock Absorber Scrapping..... 13-11
- Suspension Arms..... 13-12
 - Suspension Arm Removal..... 13-12
 - Suspension Arm Installation..... 13-12
 - Suspension Arm Disassembly..... 13-12
 - Suspension Arm Assembly..... 13-13
- Swingarm..... 13-14
 - Swingarm Removal..... 13-14
 - Swingarm Installation..... 13-14
 - Swingarm Disassembly..... 13-14
 - Swingarm Assembly..... 13-16
 - Swingarm Bearing Inspection..... 13-16
 - Swingarm Bearing Lubrication..... 13-16

13-2 SUSPENSION

Exploded View

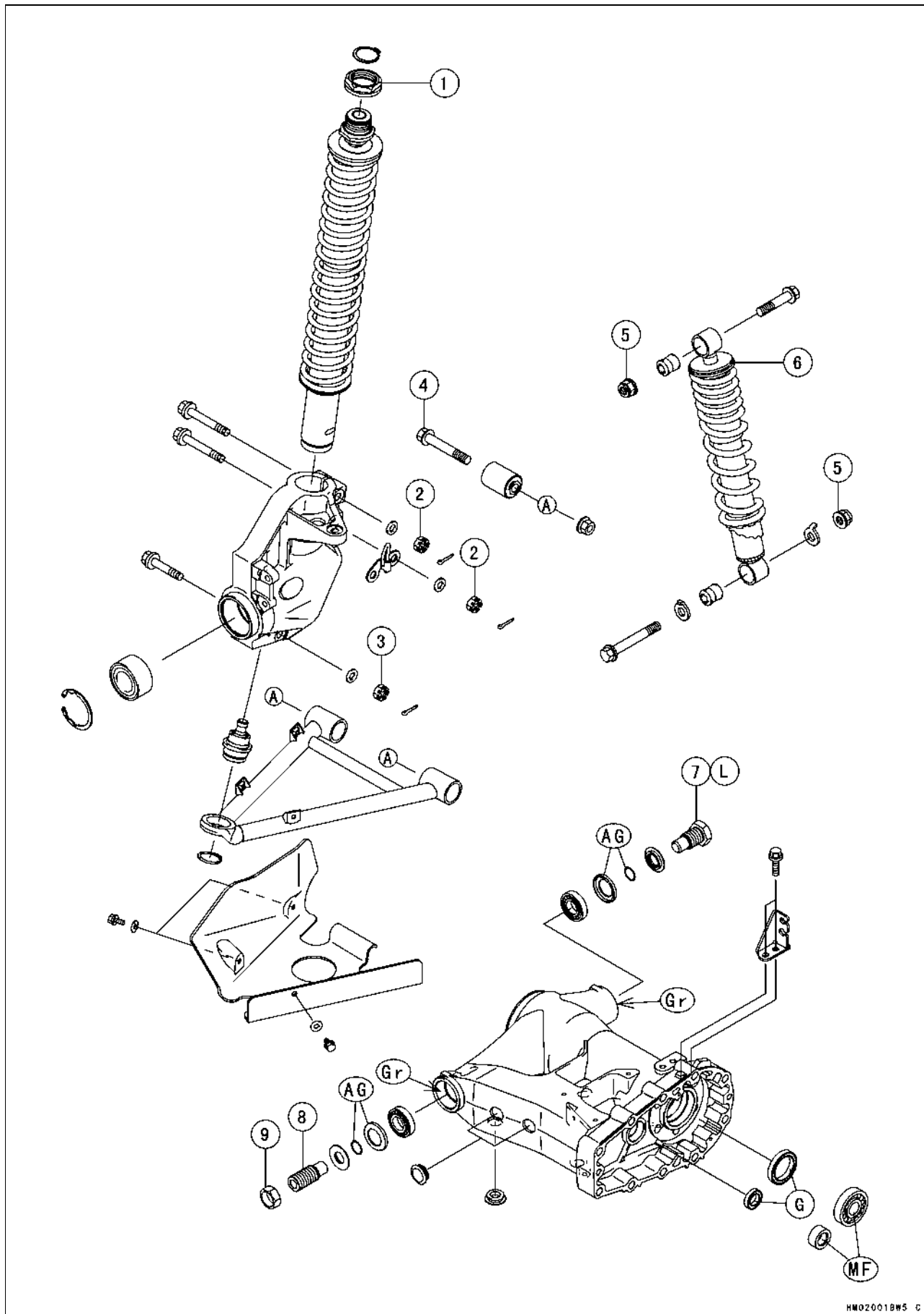

Exploded View

No.	Fastener	Torque			Remarks
		N·m	kgf·m	ft·lb	
1	Front Shock Absorber Mounting Nuts	74	7.5	54	
2	Front Shock Absorber Clamp Bolts and Nuts	47	4.8	35	
3	Steering Knuckle Joint Nut	47	4.8	35	
4	Suspension Arm Pivot Bolts	88	9.0	65	
5	Rear Shock Absorber Mounting Nuts	62	6.3	46	
6	Piston Rod Nut	49	5.0	36	
7	Swingarm Pivot Right Shaft	152	15.5	112	L
8	Swingarm Pivot Left Shaft	20	2.0	14	
9	Swingarm Pivot Left Nut	152	15.5	112	

G: Apply grease for oil seal and O-ring.

L: Apply a non-permanent locking agent.

AG: Apply grease (Amoco rykon premium grease No. 2 EP Green).

MF: Apply MOBIL FLUID 424 or equivalent oil.

Gr: Apply grease.

13-4 SUSPENSION

Specifications

Item	Standard	Service Limit (Usable Range)
Shock Absorbers: Spring preload setting position (Rear)	No. 2	1 ~ 5

Special Tools - Outside Circlip Pliers: 57001-144
Oil Seal & Bearing Remover: 57001-1058
Steering Stem Nut Wrench: 57001-1100
Bearing Driver Set: 57001-1129
Jack: 57001-1238
Holder & Guide Arbor: 57001-1476
Spacer & Holder: 57001-1477

Shock Absorbers

Front Shock Absorber Removal

- Remove:
 - Front Fender (see Frame chapter)
 - Front Inner Cover (see Frame chapter)
 - Cotter Pins [A]
 - Front Shock Absorber Clamp Bolts and Nuts [B]
 - Suspension Arm Pivot Bolts

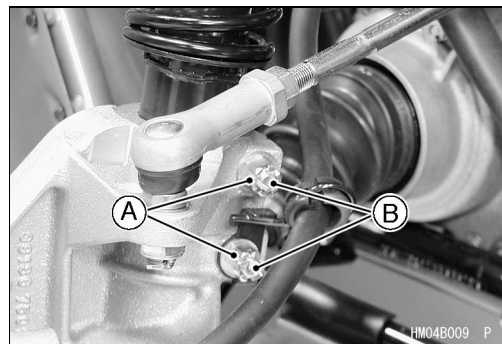

- Remove:
 - Circlip [A]
- **Special Tool - Outside Circlip Pliers: 57001-144**
- While supporting the vehicle with a jack, loosen the nut [B].
- **Special Tool - Jack: 57001-1238**
- Remove the ball joint [C] of the shock absorber from the frame bracket [D].

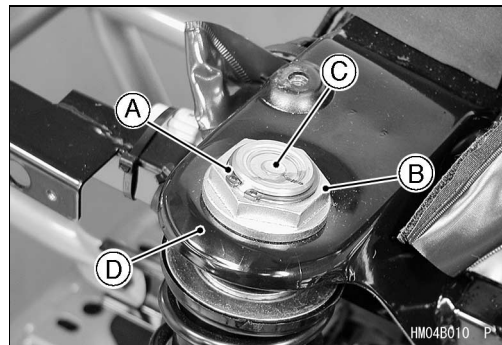

- Remove:
 - Front Shock Absorber [A]

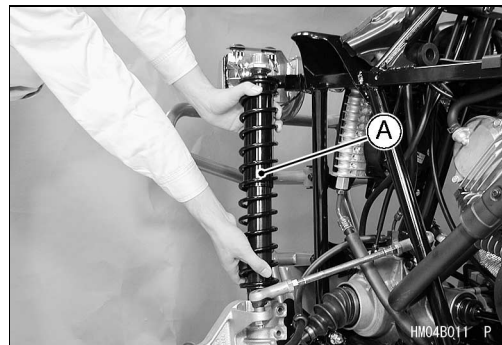

Front Shock Absorber Installation

- Insert the shock absorber into the knuckle, and align its recess [A] and the lower bolt hole [B] in the knuckle.
- Tighten:
 - Torque - Front Shock Absorber Clamp Bolts and Nuts: 47 N·m (4.8 kgf·m, 35 ft·lb)**

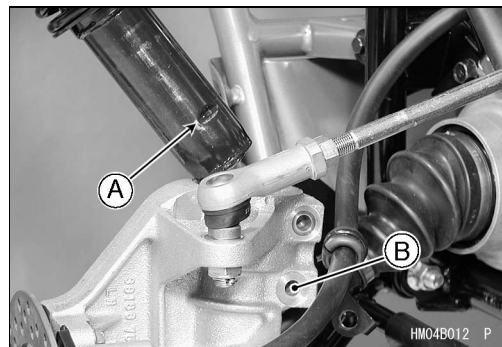

- Insert the ball joint into the frame bracket.
- Tighten the nut.
 - Torque - Front Shock Absorber Mounting Nut: 74 N·m (7.5 kgf·m, 54 ft·lb)**
- Replace the circlip with a new one.
 - Special Tool - Outside Circlip Pliers: 57001-144**
- Lower the vehicle and remove the jack.

Front Shock Absorber Inspection

Since the front shock absorbers are sealed units which cannot be disassembled, only external checks are necessary.

- ★ If one unit is damaged, replace both shock absorbers as a set. If only one unit is replaced and the two are not balanced, vehicle instability at high speed may result.

13-6 SUSPENSION

Shock Absorbers

Front Shock Absorber Spring Removal

- Remove:
 - Front Shock Absorber (see Front Shock Absorber Removal)
- Hold the holder [A] (57001-1476) and spacer [B] (57001-1477) in a vice as shown.
- Install the guide arbors [C] (57001-1476) on the holder.
- Insert the front shock absorber [D] into the center of the spacer and holder.

Special Tools - Holder & Guide Arbor: 57001-1476
Spacer & Holder: 57001-1477

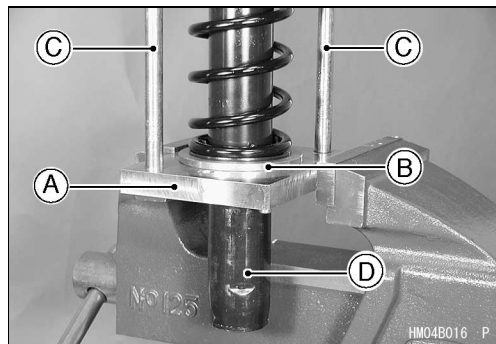

- Put the upper holder [A] (57001-1477) on upper end of the spring guide [B] and arbors so that the recess side [C] faces downward.

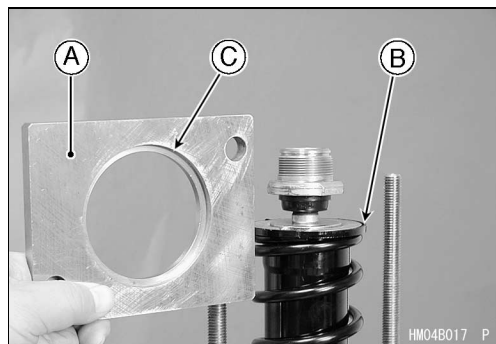

- Tighten the nuts [A] and press the spring until the spring seat stopper is free.

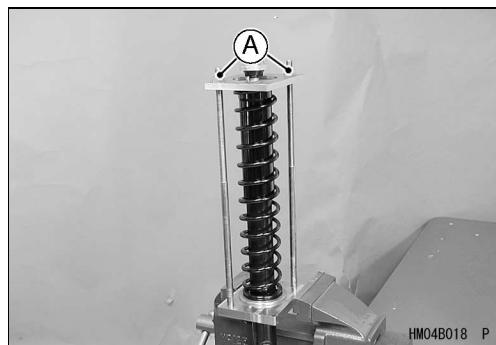

- Pull up the spring seat [A] and remove the spring seat stopper [B].

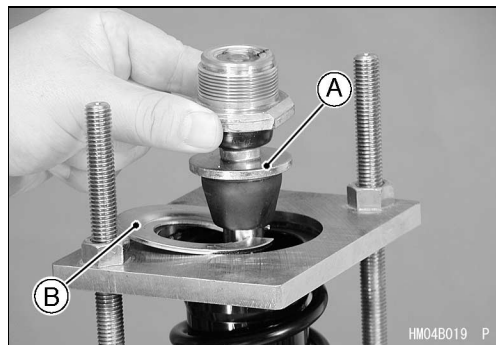

- Remove:
 - Nuts and Upper Holder
 - Spring Guide [A]
 - Spring [B]

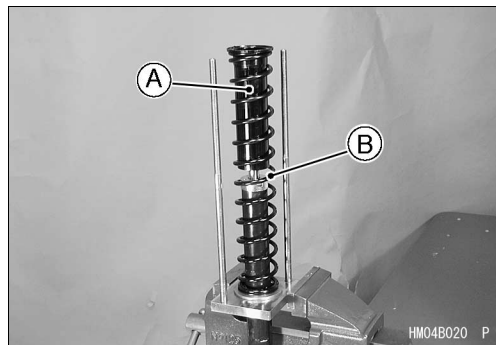

Shock Absorbers

Front Shock Absorber Spring Installation

- Set the front shock absorber [A] into the center of the spacer [B] and holder [C] (see Front Shock Absorber Spring Removal).

Special Tools - Holder & Guide Arbor: 57001-1476
Spacer & Holder: 57001-1477

- Install:
 - Spring [A]
 - Spring Guide [B]
- Put the upper holder [C] (57001-1477) on upper end of the spring guide and arbors [D] so that the recess side faces downward.
- Tighten the nuts [E] and press the spring.

- Install the spring seat stopper [A] by the reverse of removal.

- Fit the spring seat stopper under the spring seat [A].
- Remove:
 - Nuts [B]
 - Upper Holder

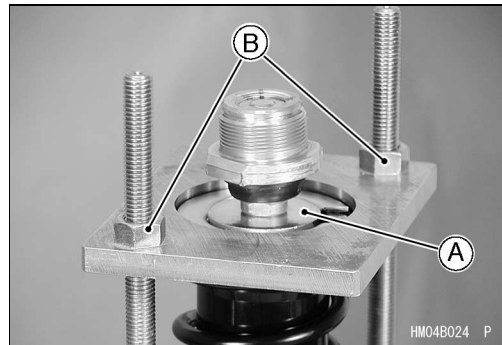
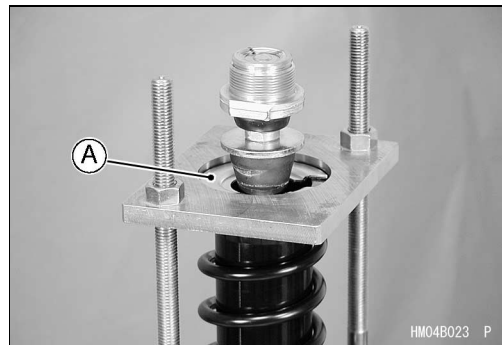
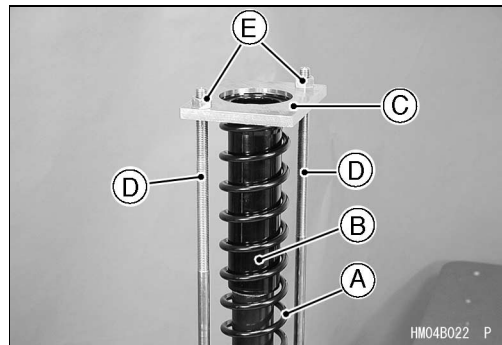
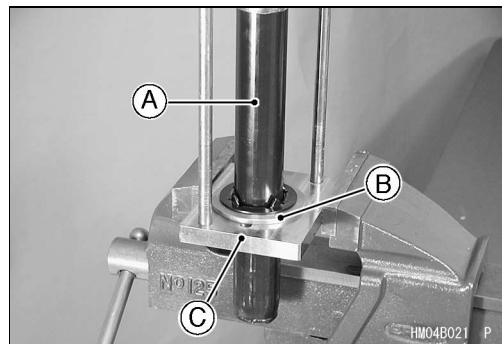

13-8 SUSPENSION

Shock Absorbers

Rear Shock Absorber Preload Adjustment

The spring adjusting sleeve [A] on rear shock absorber has 5 positions so that the spring can be adjusted for different terrain and loading conditions. If the spring action feels too soft or too stiff, adjust it in accordance with the following table.

Spring Action

Position	Spring Force	Setting	Load	Terrain	Speed
1		Soft	Light	Smooth	Low
2 (STD)		↑	↑	↑	↑
3					
4		↓	↓	↓	↓
5		Stronger	Hard	Heavy	Rough

- Turn the adjusting sleeve on rear shock absorber to the desired position with the wrench.

Special Tool - Steering Stem Nut Wrench: 57001-1100

Rear Shock Absorber Removal

- Support the vehicle on a stand or a jack so that the rear wheels are off the ground.

Special Tool - Jack: 57001-1238

- While holding the rear wheels, remove the lower and upper shock absorber mounting bolts [A], nuts, and washers.
- Remove the rear shock absorber [B].

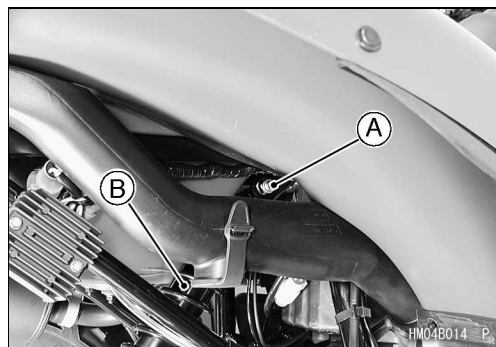
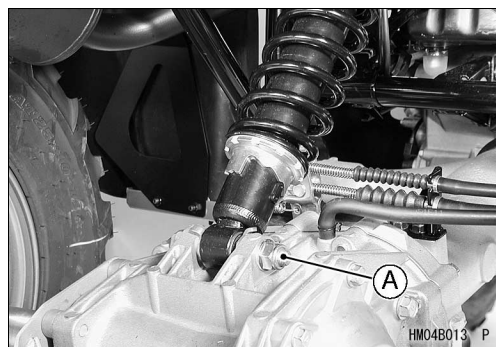
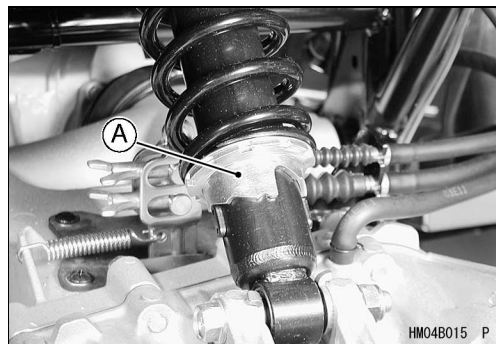

Rear Shock Absorber Installation

- Install:
 - Bushings [A]
 - Washers [B]
- Tighten:
 - **Torque - Rear Shock Absorber Mounting Nuts [C]: 62 N·m (6.3 kgf·m, 46 ft·lb)**

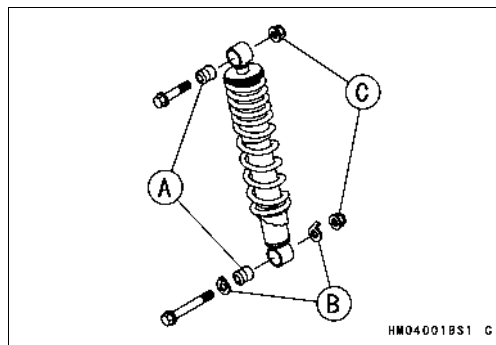

Shock Absorbers

Rear Shock Absorber Inspection

- Check the rubber bushings [A] in the upper and lower pivots.
- ★ If bushings are worn, cracked, hardened, or otherwise damaged, replace them.

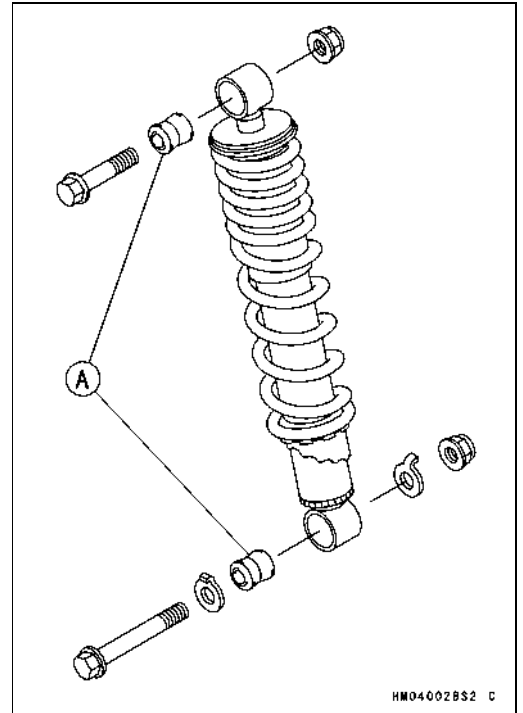

Rear Shock Absorber Spring Removal

- Remove:
 - Rear Shock Absorber (see Rear Shock Absorber Removal)
- Hold the holder [A] (57001-1476) and spacer [B] (57001-1477) in a vice as shown.
- Install the guide arbors [C] (57001-1476) on the holder.
- Insert the rear shock absorber [D] into the center of the spacer and holder.

Special Tools - Holder & Guide Arbor: 57001-1476
Spacer & Holder: 57001- 1477

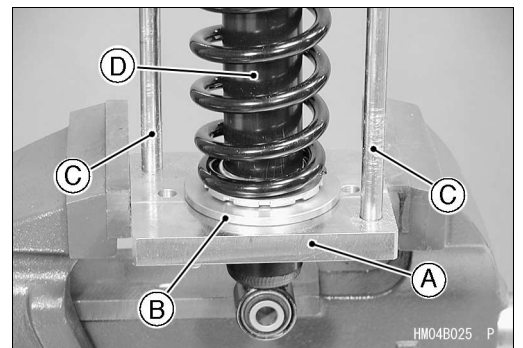

- Put the upper holder [A] (57001-1477) on upper end of the spring guide [B] and arbors [C] so that the recess side faces downward.

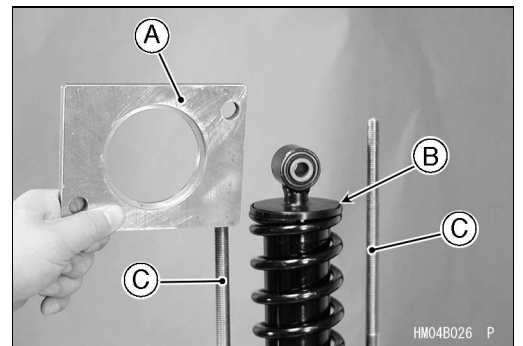

- Tighten the nuts [A] and compress the spring to loosen the piston rod nut [B].
- Pull the top joint [C] upward.

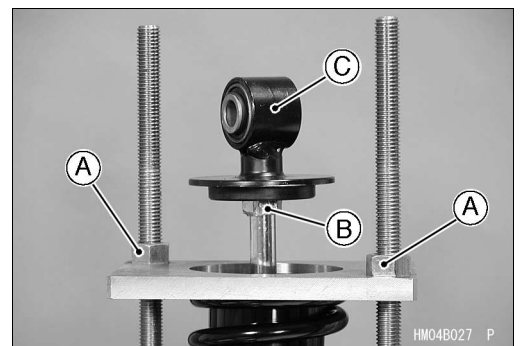

13-10 SUSPENSION

Shock Absorbers

- Holding the top joint [A] with a suitable bar [B], and loosen the piston rod nut with a wrench [C].
- Remove:
 - Top Joint

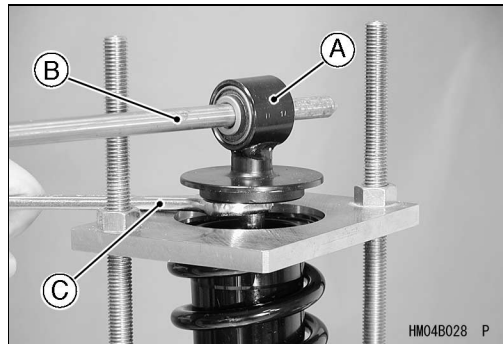

- Remove:
 - Nuts [A] and Upper Holder [B]
 - Spring Guide [C]
 - Spring [D]

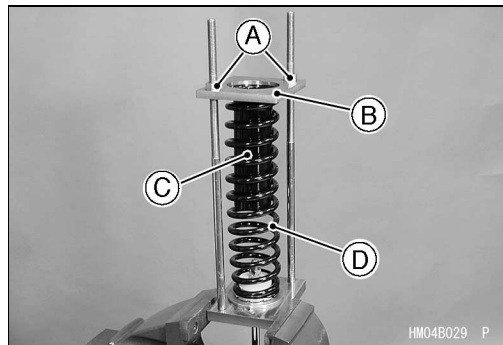

Rear Shock Absorber Spring Installation

- Tighten the piston rod nut [A] fully by hand.
- Insert the damper assembly [B] into the center of the spacer and holder (see Rear Shock Absorber Spring Removal).

Special Tools - Holder & Guide Arbor: 57001-1476
Spacer & Holder: 57001-1477

- Install:
 - Adjusting Sleeve [C]
 - Spring Seat [D] (Stepped side facing upward.)
- Install the spring [A] with the smaller end facing downward on the spring seat.
- Install the spring guide [B] with the smaller end facing downward.

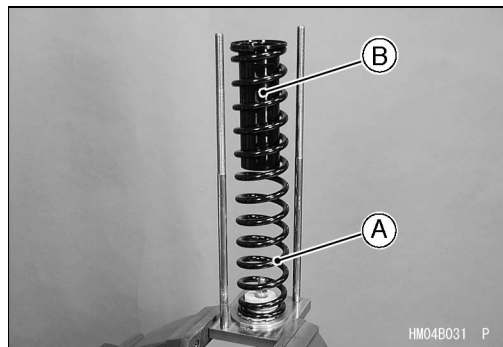
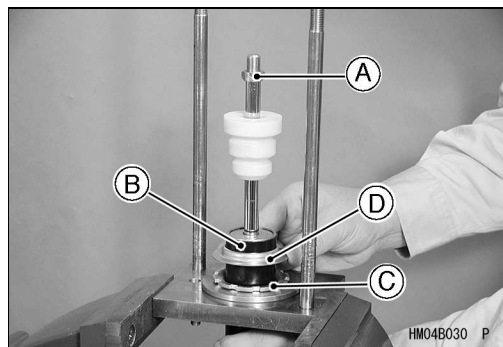

- Put the upper holder [A] (57001-1477) on upper ends of the spring guide [B] and arbors [C] so that the recess side faces downward.
- Tighten the nuts [D] and compress the spring.

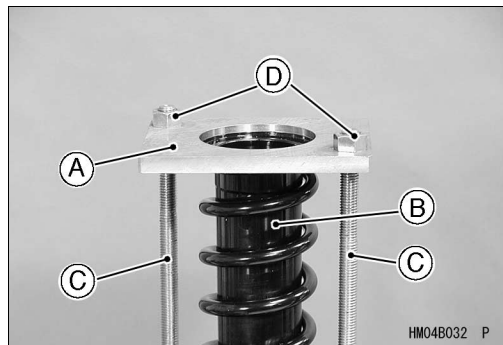

Shock Absorbers

- Tighten the top joint [A] fully by hand.
- Tighten the piston rod nut [B] against the top joint.
Torque - Piston Rod Nut: 49 N·m (5.0 kgf·m, 36 ft·lb)
- Fit the top joint on the spring guide.

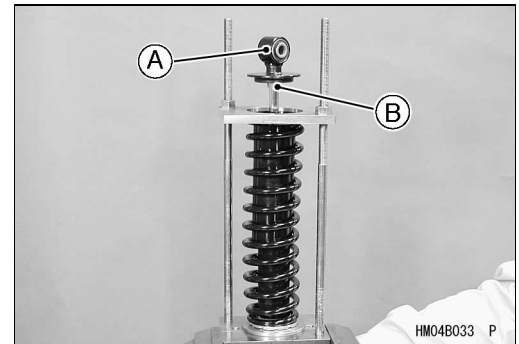

- Remove:
Nuts [A]
Upper Holder [B]

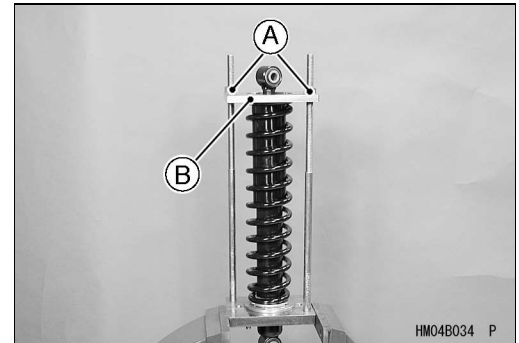

Rear Shock Absorber Scrapping

⚠ WARNING

Since the rear shock absorber contains nitrogen gas, do not incinerate or disassemble the rear shock absorber. Before a rear shock absorber is scrapped, drill a hole at a point about 15 mm (0.59 in.) [A] up from the bottom of the cylinder to release the nitrogen gas completely. Wear safety glasses when drilling the hole, as the gas may blow out bits of drilled metal when the hole opens.

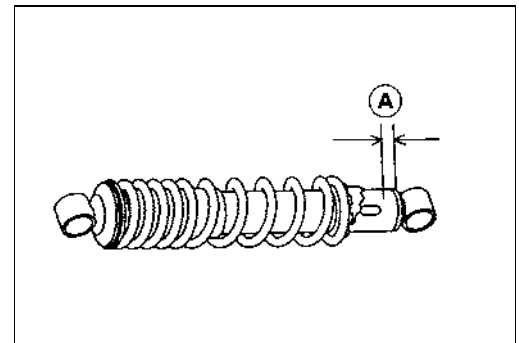

13-12 SUSPENSION

Suspension Arms

Suspension Arm Removal

- Remove:
 - Front Wheel (see Wheels/Tires chapter)
 - Knuckle Joint Bolt [A]
 - Knuckle Joint [B] (from Knuckle)
 - Suspension Arm Pivot Bolts [C]
 - Suspension Arm [D]

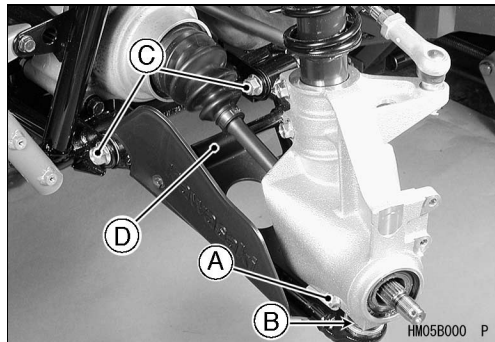

Suspension Arm Installation

- Tighten:
 - Torque - Suspension Arm Pivot Bolts: 88 N·m (9.0 kgf·m, 65 ft·lb)
 - Steering Knuckle Joint Nuts: 47 N·m (4.8 kgf·m, 35 ft·lb)

Suspension Arm Disassembly

- Remove:
 - Axle Guard Bolts [A] and Washers
 - Axle Guard [B]
 - Circlip [C]
- Press out the knuckle joint [D].

CAUTION
Do not remove the knuckle joint grease seal. It is packed with grease.

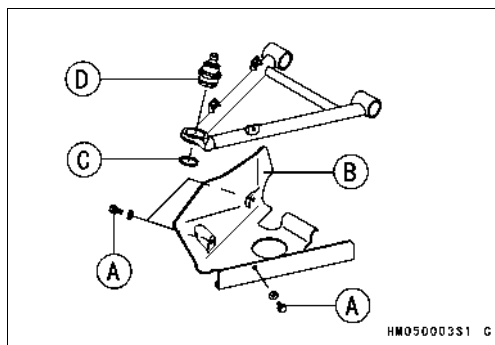

- Remove:
 - Rubber Bushings [A]

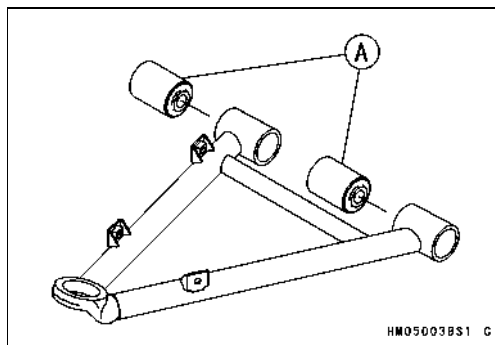

Suspension Arms

Suspension Arm Assembly

- Position the bushings [A] in the suspension arm [B] as shown.
[C] 0.4 ~ 0.6 mm (0.016 ~ 0.024 in.)
- Confirm that the knuckle joint is smooth motion after installed.

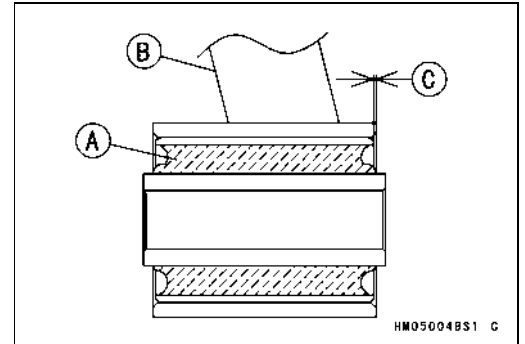

13-14 SUSPENSION

Swingarm

Swingarm Removal

- Support the vehicle on a stand or a jack so that the rear wheels are off the ground.

Special Tool - Jack: 57001-1238

- Remove:
 - Rear Final Gear Case (see Final Drive chapter)
 - Swingarm Pivot Left Nut [A]
 - Swingarm Pivot Left Shaft [B]

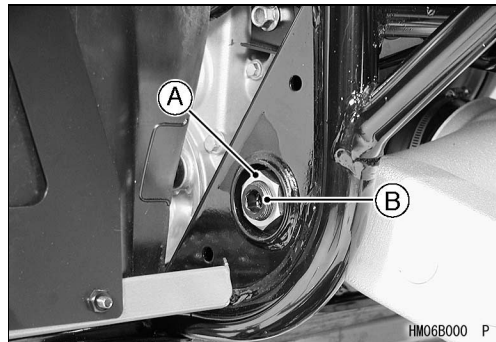

- Loosen:
 - Boot Clamp Screw [A]
- Remove:
 - Boot
 - Swingarm Pivot Right Shaft [B]
 - Swingarm [C]

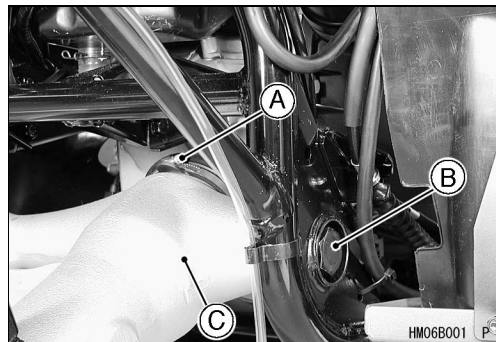

Swingarm Installation

- Apply molybdenum disulfide grease to the spline of the output shaft [A].
- Fit the propeller shaft [B] on the output shaft.

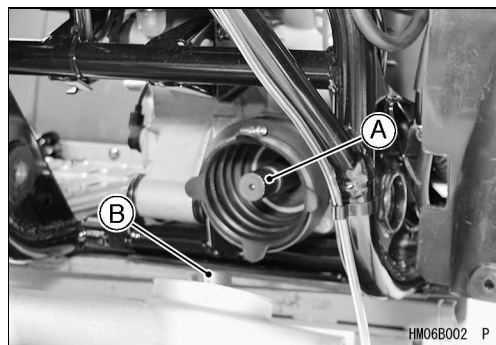

- Apply a non-permanent locking agent:
 - Swingarm Pivot Right Shaft [A]
- Tighten:
 - Torque - Swingarm Pivot Right Shaft: 152 N·m (15.5 kgf·m, 112 ft·lb)**
- Tighten:
 - Torque - Swingarm Pivot Left Shaft [B]: 20 N·m (2.0 kgf·m, 14 ft·lb)**
 - Swingarm Pivot Left Nut [C]: 152 N·m (15.5 kgf·m, 112 ft·lb)**
- Fit the boot on the swingarm, and tighten the clamp screw.

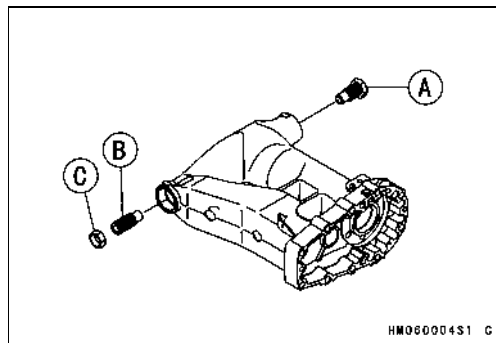

Swingarm Disassembly

- Remove:
 - Collars [A]
 - O-ring [B]

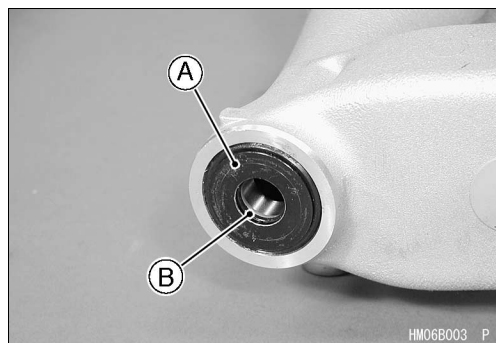

Swingarm

- Remove:
Oil Seal [A]

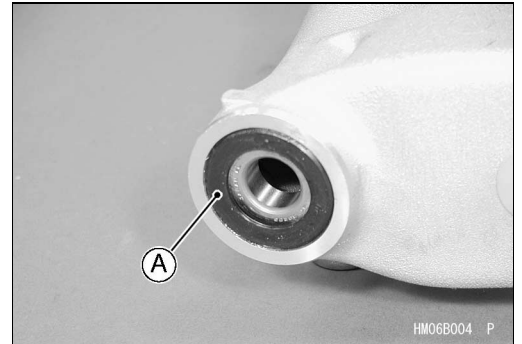

- Remove:
Tapered Roller Bearing [A]

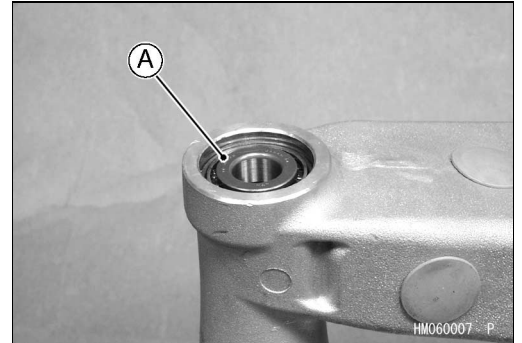

- Remove:
Outer Race [A]

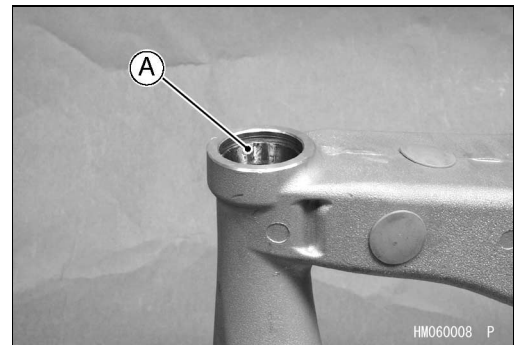

- Remove:
Ball Bearing [A]
Special Tool - Oil Seal & Bearing Remover [B]: 57001-1058

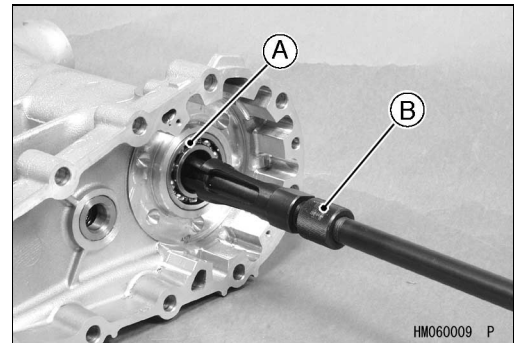

- Remove:
Oil Seal [A]

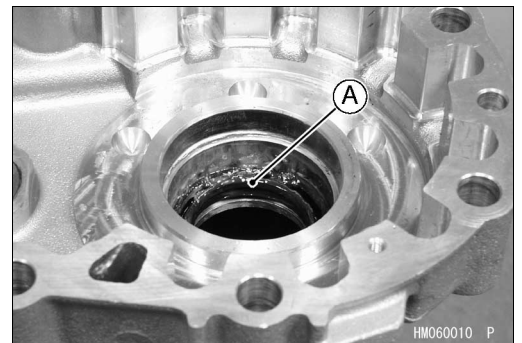

13-16 SUSPENSION

Swingarm

- Remove:
 - Collar [A]
 - Oil Seal [B]

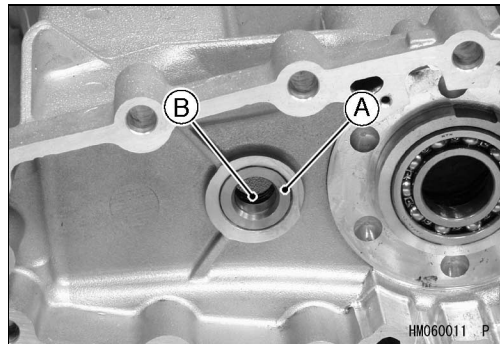

Swingarm Assembly

- Apply grease:
 - Inside [A] of Oil Seals
- Apply MOBIL FLUID 424 or Equivalent:
 - Surface of Collar [B]
- Install the following parts as shown.
 - Brake Lever Oil Seal [C]
 - [D] = 14.5 ± 0.1 mm (0.571 ± 0.004 mm)
 - Collar (level with surface)
 - Propeller Shaft Oil Seal [E]
 - [F] = 25 ± 0.1 mm (0.984 ± 0.004 mm)
 - Ball Bearing [G] (level with surface)
- Apply Amoco Rykon Premium Grease No.2 EP Green:
 - Inside of Oil Seals [A]
 - O-rings [B]
- Install the following parts as shown.
 - Tapered Roller Bearing [C]
 - Oil Seal (level with surface)
 - O-ring
 - Collar [D]

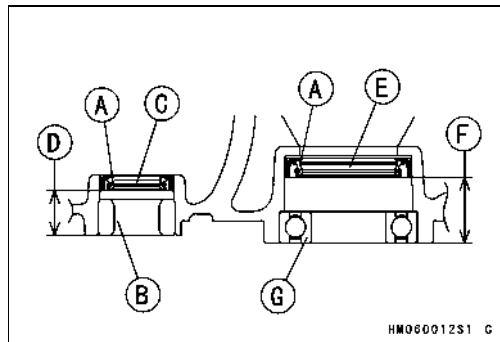

Special Tool - Bearing Driver Set: 57001-1129

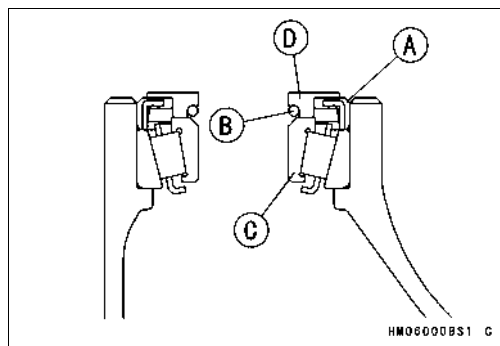

Swingarm Bearing Inspection

- Remove the rear final gear case (see Final Drive chapter).
- Move the swingarm up and down to check for abnormal friction, and push and pull it back and forth to check for bearing play.
- ★ If abnormal friction is felt, the bearings are damaged. Replace the oil seals and both left and right bearings.
- The play developed during use may indicate bearing damage. In this case, remove the swingarm and inspect the bearings. Replace both left and right bearings, if either of the bearings is damaged.

Swingarm Bearing Lubrication

- Remove the swingarm.
- Using a high flash-point solvent, wash the bearings clean of grease, and dry them.
- Inspect the bearings and oil seals for abrasion, color change, or other damage.
- Apply grease to the outer races [A], and pack the tapered roller bearings [B] with the same grease.
- Apply Amoco Rykon Premium Grease No. 2 EP (green) to the inside of the oil seals.
- Install the swingarm (see Swingarm Installation).

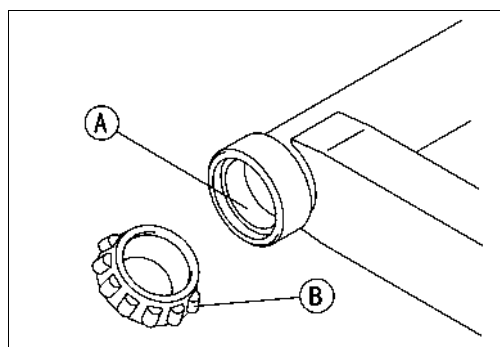

Steering

Table of Contents

Exploded View.....	14-2
Specifications.....	14-4
Steering.....	14-5
Steering Stem Removal.....	14-5
Steering Stem Installation.....	14-5
Steering Knuckle Removal.....	14-6
Steering Knuckle Installation.....	14-7
Steering Knuckle Bearing Removal.....	14-7
Steering Knuckle Bearing Installation.....	14-7
Tie-Rod Removal.....	14-7
Tie-Rod Installation.....	14-7
Tie-Rod End Removal.....	14-8
Tie-Rod End Installation.....	14-8
Steering Maintenance.....	14-9
Steering Inspection.....	14-9
Steering Stem Straightness.....	14-9
Steering Lubrication.....	14-9
Steering Stem Clamp Inspection.....	14-9
Steering Stem Bearing Inspection.....	14-9
Steering Knuckle Bearing Inspection.....	14-10
Tie-Rod End and Steering Knuckle Joint Inspection.....	14-10
Handlebar.....	14-11
Handlebar Removal.....	14-11
Handlebar Installation.....	14-11

14-2 STEERING

Exploded View

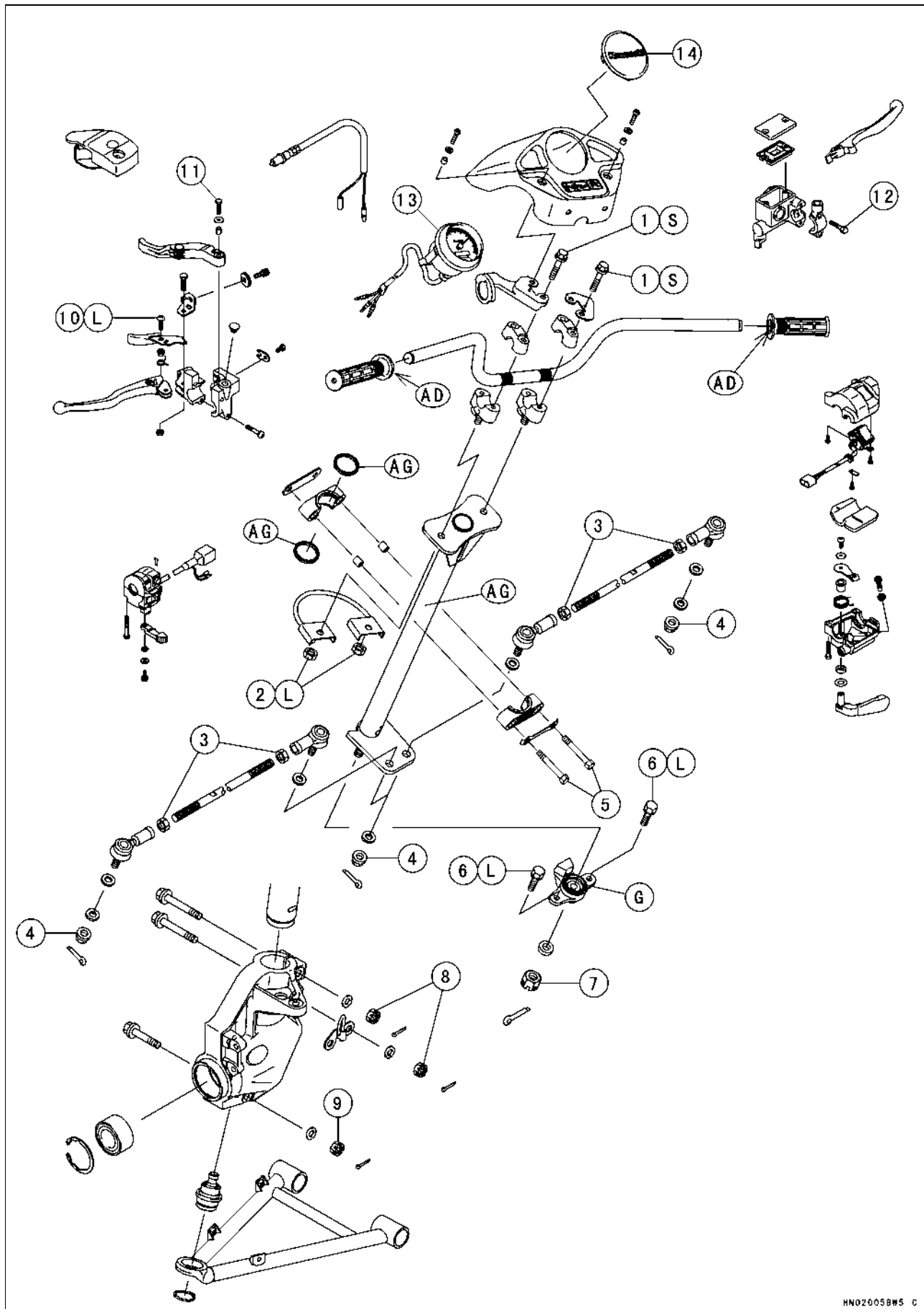

Exploded View

No.	Fastener	Torque			Remarks
		N·m	kgf·m	ft·lb	
1	Handlebar Holder Bolts	27	2.8	20	S
2	Handlebar Lower Holder Nuts	37	3.8	27	L
3	Tie-Rod Adjusting Sleeve Locknuts	37	3.8	27	
4	Tie-Rod End Nuts	42	4.3	31	
5	Steering Stem Clamp Bolts	25	2.5	18	
6	Steering Stem Bearing Joint Bolts	–	–	–	L
7	Steering Stem Bottom End Nut	62	6.3	46	
8	Front Shock Absorber Clamp Bolts and Nuts	47	4.8	35	
9	Steering Knuckle Joint Nut	47	4.8	35	
10	Parking Brake Lever Screw	2.2	0.22	19 in·lb	L
11	Variable Differential Control Lever Bolt	3.5	0.36	31 in·lb	
12	Master Cylinder Clamp Bolts	8.8	0.9	78 in·lb	

13: Speedometer (other than U.S.A. model)

14: Cover (U.S.A. model)

L: Apply a non-permanent locking agent.

G: Apply greae for oil seal and O-ring.

AD: Apply adhesive agent.

AG: Apply grease (Amoco rykon premium grease No. 2 EP Green).

S: Follow the specific tightening sequence.

14-4 STEERING

Specifications

Item	Standard	Service Limit
Tie-Rods: Tie-Rod Length	315 ± 0.7 mm (12.4 ± 0.03 in.)	---

Special Tools - Inside Circlip Pliers: 57001-143

Bearing Driver Set: 57001-1129

Steering

Steering Stem Removal

- Remove:
 - Fuel Tank (see Fuel System chapter)
 - Front Wheels (see Wheels/Tires chapter)
 - Cotter Pins [A]
 - Tie-Rod End Nuts [B] and Tie-Rod End
 - Steering Stem Bearing Housing Bolts [C] (right and left)

CAUTION

Do not loosen the locknuts [D] at the ends of the tie-rod adjusting sleeve, or the toe-in of the front wheels will be changed.

- Remove:
 - Handlebar Holder Mounting Nuts [A]
 - Handlebar Assembly

- Flatten out the bended parts [A] of the lockwasher.
- Remove:
 - Steering Clamp Bolts [B], Lockwasher, and Plate
 - Steering Clamps [C] and Collars
 - Grease Seals [D] (upper and lower)

- Pull the steering stem out of the frame.
- Remove:
 - Cotter Pin [A]
 - Steering Stem Bottom End Nut [B]
 - Collar [C]
 - Steering Stem Bearing [D]

Steering Stem Installation

- Full grease up the seal grooves [A] in the steering stem bearing [B].
- Install:
 - Collar
- Tighten:
 - Torque - Steering Stem Bottom End Nut: 62 N·m (6.3 kgf·m, 46 ft·lb)**

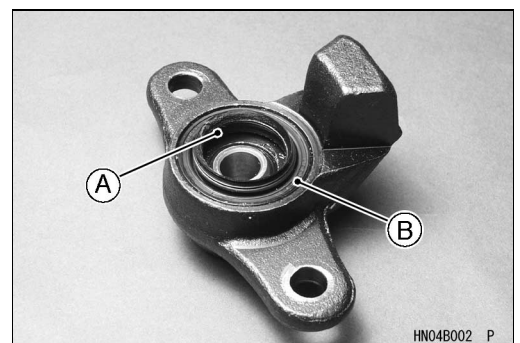
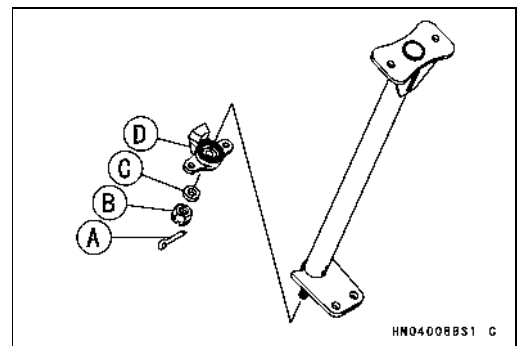
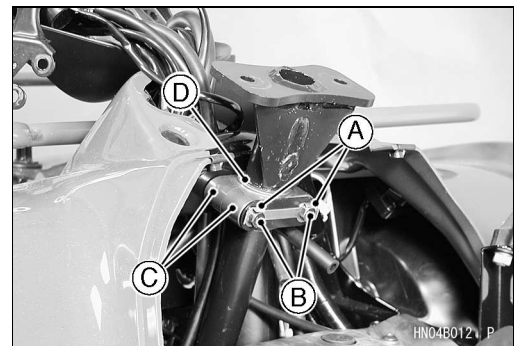
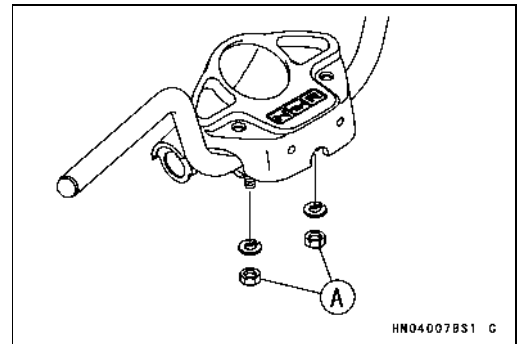
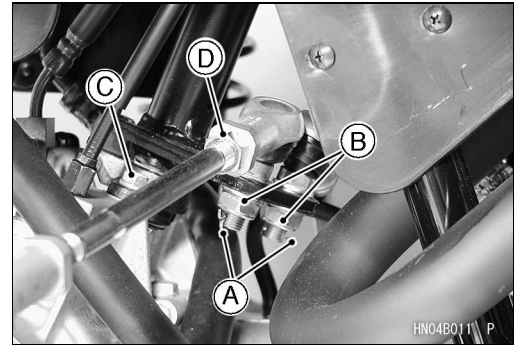

14-6 STEERING

Steering

- Bend both ends of the cotter pin [A] as shown.
Steering Stem Bottom End Nut [B]

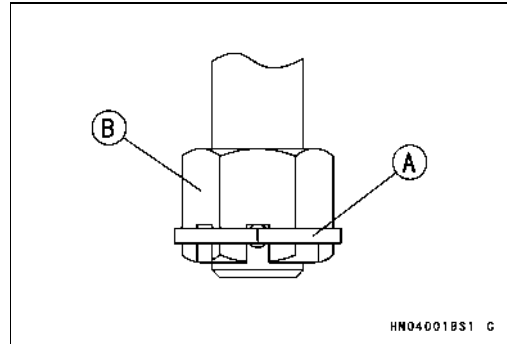

- Apply a non-permanent locking agent:
Steering Stem Bearing Joint Bolts [A]

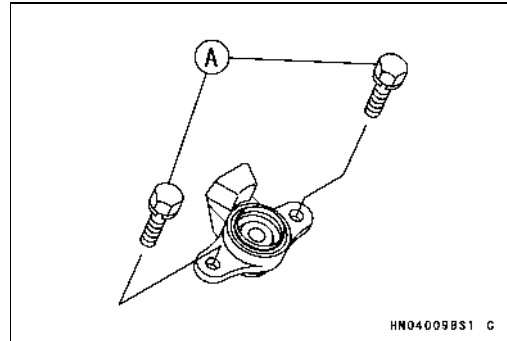

- Apply Amoco Rykon Premium Grease No.2 EP (Green):
Inside of Grease Seals [A]
Steering Stem [B]
- Install:
Grease Seals
Steering Clamps [C] and Collars [D]
Plate [E], Lockwasher [F], and Steering Stem Clamp Bolts [G]
- Tighten:
Torque - Steering Stem Clamp Bolts: 25 N·m (2.5 kgf·m, 18 ft·lb)
Tie-Rod End Nuts: 42 N·m (4.3 kgf·m, 31 ft·lb)

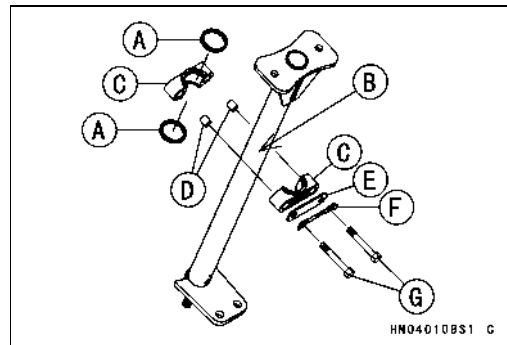

- Bend the lockwasher along the bolt head.
- Inspect the toe-in (see Wheels/Tires chapter).

Steering Knuckle Removal

- Remove:
Front Wheel and Hub (see Wheel/Tires chapter)
Brake Caliper (see Brakes chapter)
Tie-Rod End Nut and Tie-Rod End [A]

CAUTION

Do not loosen the locknuts at the ends of the tie-rod adjusting sleeve [B], or the toe-in of the front wheels will be changed.

- Remove:
Front Shock Absorber Clamp Bolts [C] and Nuts
Knuckle Joint Bolt [D] and Nut
- Remove the steering knuckle [E] from the front axle and front shock absorber.

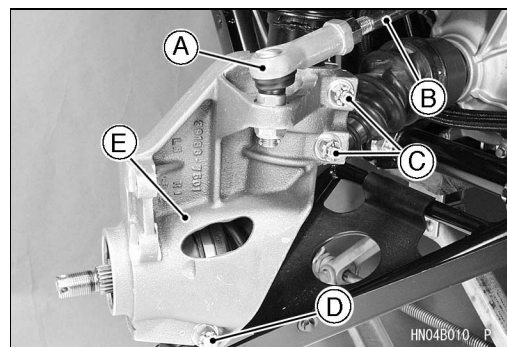

Steering

Steering Knuckle Installation

- Inspect the spherical bearing [A].
- ★ If roughness, excessive play, or seizure is found, replace the knuckle joint [B].
- Clean the shanks [C] of the knuckle joint.
- Check that the joint boot [D] is not torn, worn, deteriorated, or is leaking grease.
- Tighten:
 - Torque - Steering Knuckle Joint Nut: 47 N·m (4.8 kgf·m, 35 ft·lb)**
 - Front Shock Absorber Clamp Nuts: 47 N·m (4.8 kgf·m, 35 ft·lb)**
 - Tie-Rod End Nut: 42 N·m (4.3 kgf·m, 31 ft·lb)**

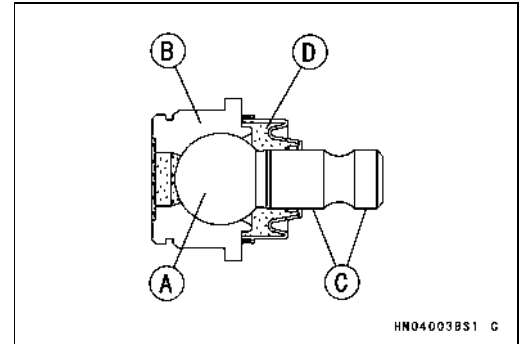

Steering Knuckle Bearing Removal

- Remove:
 - Steering Knuckle (see Steering Knuckle Removal)
 - Circlip [A]
- Special Tool - Inside Circlip Pliers [B]: 57001-143**
- Drive the bearing out using a suitable bearing driver from the bearing driver set.
- Special Tool - Bearing Driver Set: 57001-1129**

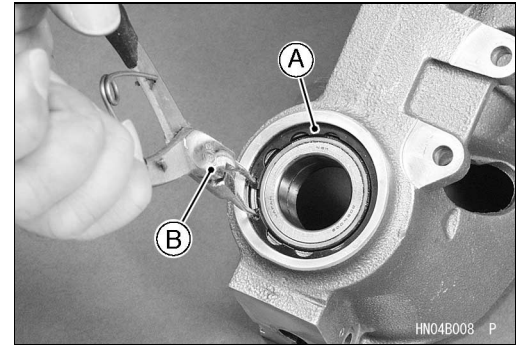

Steering Knuckle Bearing Installation

- The marked side of the bearing faces outward.
- Press in the bearing until it is bottomed.
- Special Tool - Bearing Driver Set [A]: 57001-1129**
- Replace the circlip with a new one.
- Special Tool - Inside Circlip Pliers: 57001-143**

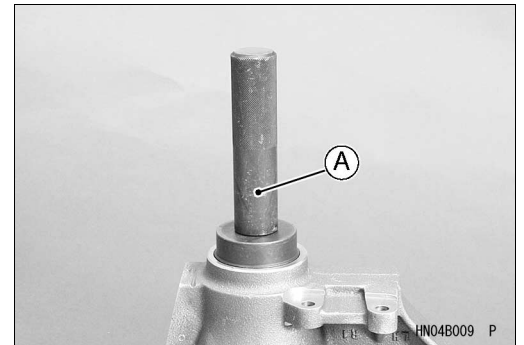

Tie-Rod Removal

- Remove:
 - Cotter Pins [A] and Tie-Rod End Nuts
 - Tie-Rod [B]

CAUTION

When removing the tie-rod, be careful not to bend it. Do not loosen the locknuts [C] at the end of the tie-rod adjusting sleeve, or the toe-in of the front wheels will be changed.

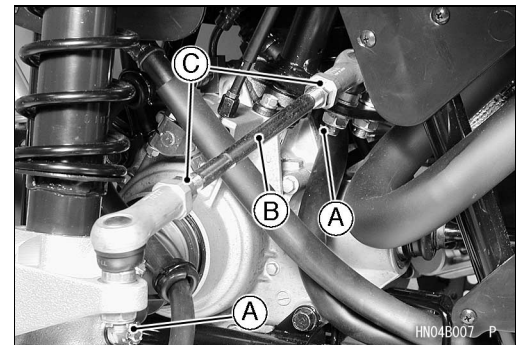

Tie-Rod Installation

- The right and left tie-rods are identical.
- Tighten:
 - Torque - Tie-Rod End Nuts: 42 N·m (4.3 kgf·m, 31 ft·lb)**
- Inspect the toe-in (see Wheels/Tires chapter).

14-8 STEERING

Steering

Tie-Rod End Removal

- Remove the tie-rod (see Tie-Rod Removal).
- Holding the tie-rod flattened area [A], loosen the locknut [B] and unscrew the tie-rod end [C].

NOTE

- The locknut near the flattened area [D] on the tie-rod has left-hand threads. Turn the wrench clockwise (as viewed from the joint end) for loosening.

CAUTION

Do not remove the grease seal. It is packed with grease.

Tie-Rod End Installation

- Check that the seal lip [A] is on the shank [B].

- Install the tie-rod ends so that the tie-rod has the correct length [A], and both visible thread lengths [B] are equal.

Tie-Rod Length

Standard: 315 ± 0.7 mm (12.4 ± 0.03 in.)

- Tighten:

Torque - Tie-Rod Adjusting Sleeve Locknuts: 37 N·m (3.8 kgf·m, 27 ft·lb)

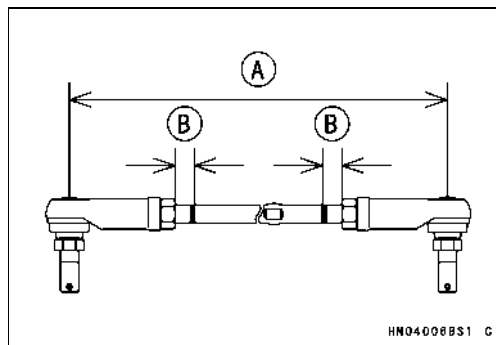
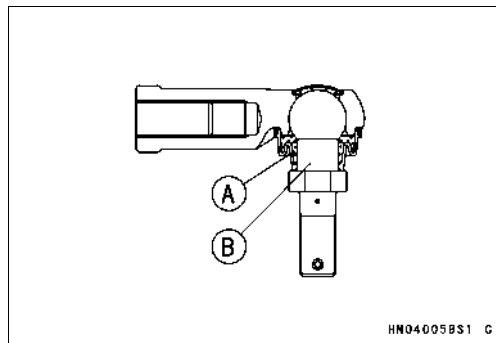
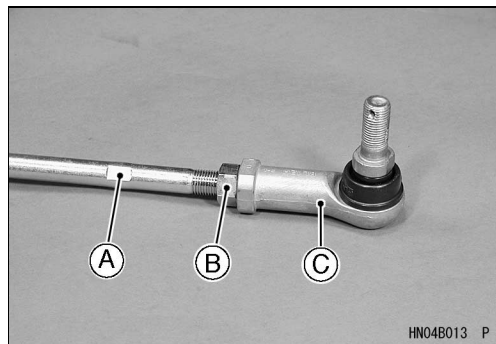

Steering Maintenance

Steering Inspection

- Refer to Steering Inspection in Periodic Maintenance chapter.

Steering Stem Straightness

- Remove the steering stem (see Steering Stem Removal).
- Check the steering stem for straightness.
- Use a straightedge along the stem.
- ★ If the steering stem is bent, replace the steering stem.

Steering Lubrication

- Lubricate the steering stem clamps.
- Remove the steering stem (see Steering Stem Removal).
- Wipe all the old grease off the steering stem, bearing sleeves, and out of the grease seals.
- Apply Amoco Rykon Premium Grease No. 2 EP (Green) to the steering stem [A], grease seals [B], and mating surface [C] of the clamp.

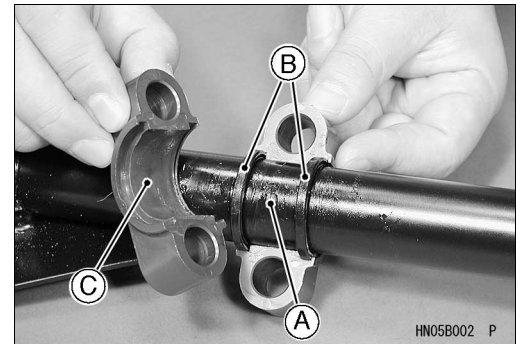

- Lubricate the steering stem bearing [A].
- Remove the steering stem bearing.
- Pack the grease seal lips with grease.

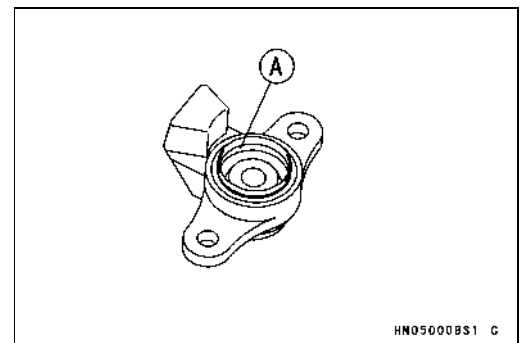

Steering Stem Clamp Inspection

- Inspect the steering stem clamps [A].
- ★ If roughness, excessive play, or seizure is found, replace both clamps.

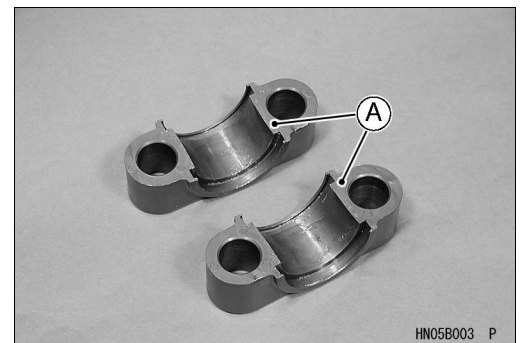

Steering Stem Bearing Inspection

- Inspect the spherical bearing [A].
- ★ If roughness, excessive play, or seizure is found, replace the steering stem bearing.
- Inspect the upper and lower grease seals [B].
- ★ If damage, wear or deterioration is found, replace the steering stem bearing.

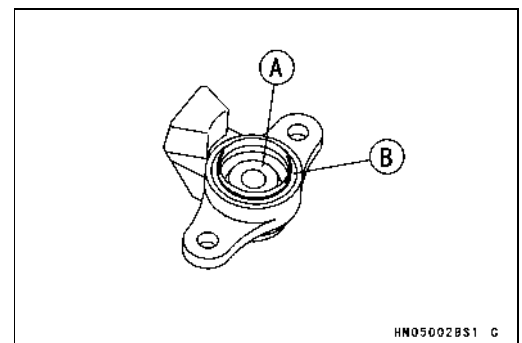

14-10 STEERING

Steering Maintenance

Steering Knuckle Bearing Inspection

CAUTION

Do not remove any bearings for inspection.

- Remove the steering knuckle (see Steering Knuckle Removal).
- Examine the bearing seal [A] for tears or leakage.
- ★ If the seal is torn or is leaking, replace the bearing.
- Turn [B] the bearing back and forth while checking for roughness or binding.
- ★ If roughness or binding is found, replace the bearing.

Tie-Rod End and Steering Knuckle Joint Inspection

- Inspect each spherical bearing [A].
- ★ If roughness, excessive play, or seizure is found, replace the tie-rod end, or steering knuckle joint.
- Inspect each grease seal [B].
- ★ If damage, wear or deterioration is found, replace the tie-rod end, or steering knuckle joint.

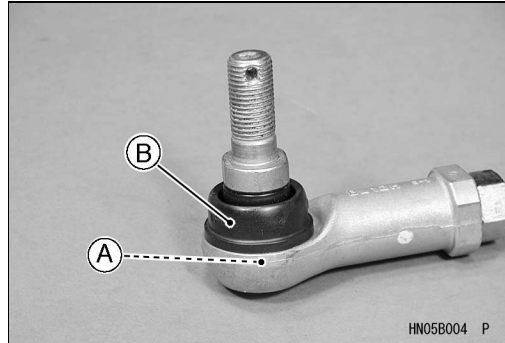
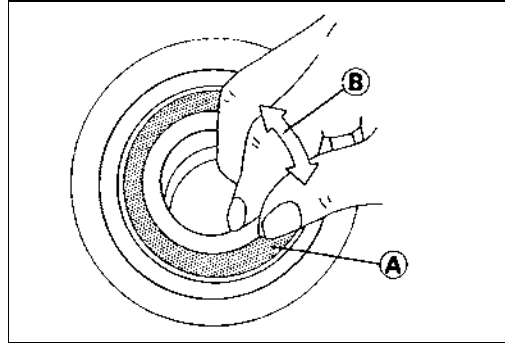

Handlebar

Handlebar Removal

- Remove:
 - Throttle Case
 - Front Brake Master Cylinder
 - Left-hand Switch Housing
 - Rear Brake Lever Assembly
 - Handlebar Cover Assembly
 - Handlebar Holder Bolts [A] and Brackets [B]
 - Handlebar Holders [C]
 - Handlebar [D]

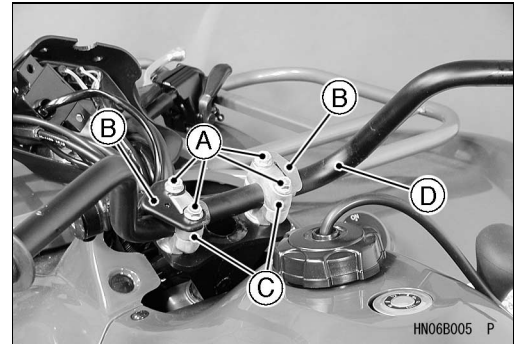

Handlebar Installation

- Install the handlebar lower holder [A] on the steering stem bracket [B] so that the projections [C] face rearward.

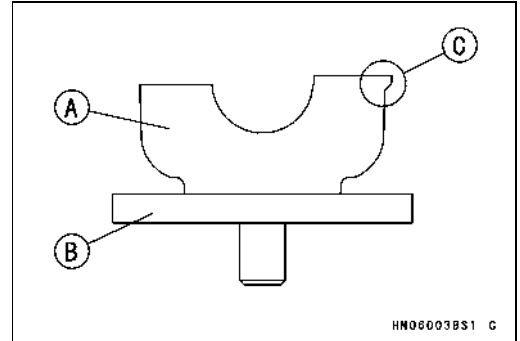

- Apply a non-permanent locking agent to the holder nuts [A] and tighten them.
- Tighten:
 - Torque - Handlebar Lower Holder Nuts: 37 N·m (3.8 kgf·m, 27 ft·lb)**

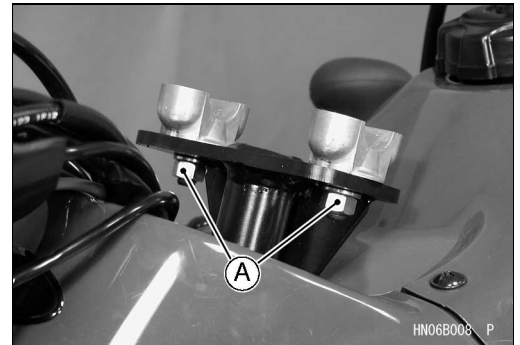

- Install the handlebar so that the angle of the handlebar is 0 ~ 5 degrees [A] as shown.

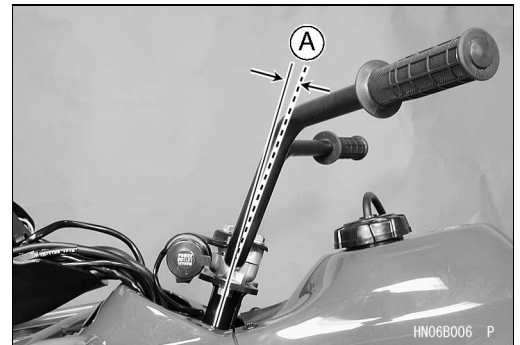

- Install the brackets [A].
- Tighten the holder rear bolts [B] first and then the front bolts [C].
 - Torque - Handlebar Holder Bolts: 27 N·m (2.8 kgf·m, 20 ft·lb)**
- If the holder is correctly installed, there will be no gap at the rear and an even gaps [D] at the front after tightening.

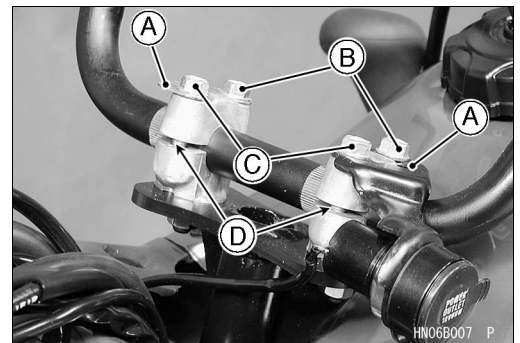

14-12 STEERING

Handlebar

- Install the left switch housing [C] on the handlebar [B] so that the opening angle is 40° [A] or less.

NOTE

- Do not open the housing more than 40° , the built-in parts in the housing may be damaged.

- Install:
 - Left Switch Housing [A]
 - Rear Brake Lever Assembly [B]
 - [C] = 3 mm (0.12 in.)

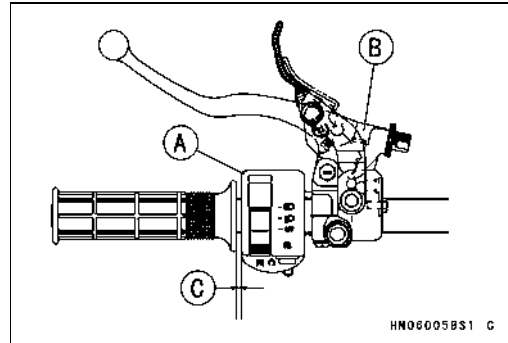
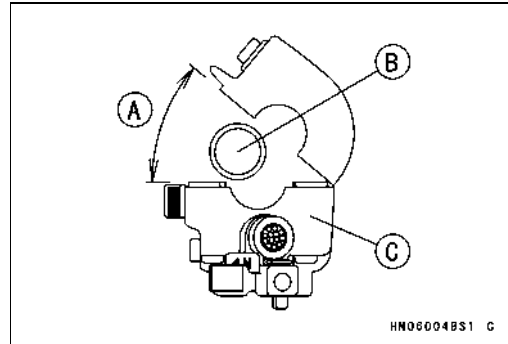

Frame

Table of Contents

Exploded View.....	15-2
Specifications.....	15-8
Seat.....	15-9
Seat Removal.....	15-9
Seat Installation.....	15-9
Carriers.....	15-10
Front Carrier Removal.....	15-10
Front Carrier Installation.....	15-10
Rear Carrier Removal.....	15-10
Rear Carrier Installation.....	15-10
Fenders.....	15-12
Front Fender Removal.....	15-12
Front Fender Installation.....	15-12
Rear Fender Removal.....	15-12
Rear Fender Installation.....	15-13
Covers.....	15-14
Headlight Cover Removal.....	15-14
Headlight Cover Installation.....	15-14
Front Inner Cover Removal.....	15-14
Front Inner Cover Installation.....	15-15
Fuel Tank Cover Removal.....	15-15
Fuel Tank Cover Installation.....	15-15
Left Side Cover Removal.....	15-15
Exhaust Pipe Cover Removal.....	15-15
Guards.....	15-17
Front Guard Removal.....	15-17
Front Lower Guard Removal.....	15-17
Front Guards Installation.....	15-17
Engine Bottom Guard Removal.....	15-18
Engine Bottom Guard Installation.....	15-18
Rear Bottom Guard Removal.....	15-18
Rear Bottom Guard Installation.....	15-18
Flaps and Footboards.....	15-19
Front Flap Removal.....	15-19
Front Flap Installation.....	15-19
Rear Flap Removal.....	15-19
Rear Flap Installation.....	15-19
Footboard Removal.....	15-19
Footboard Installation.....	15-20
Trailer Hitch Bracket.....	15-21
Trailer Hitch Bracket Removal.....	15-21
Trailer Hitch Bracket Installation.....	15-21

15-2 FRAME

Exploded View

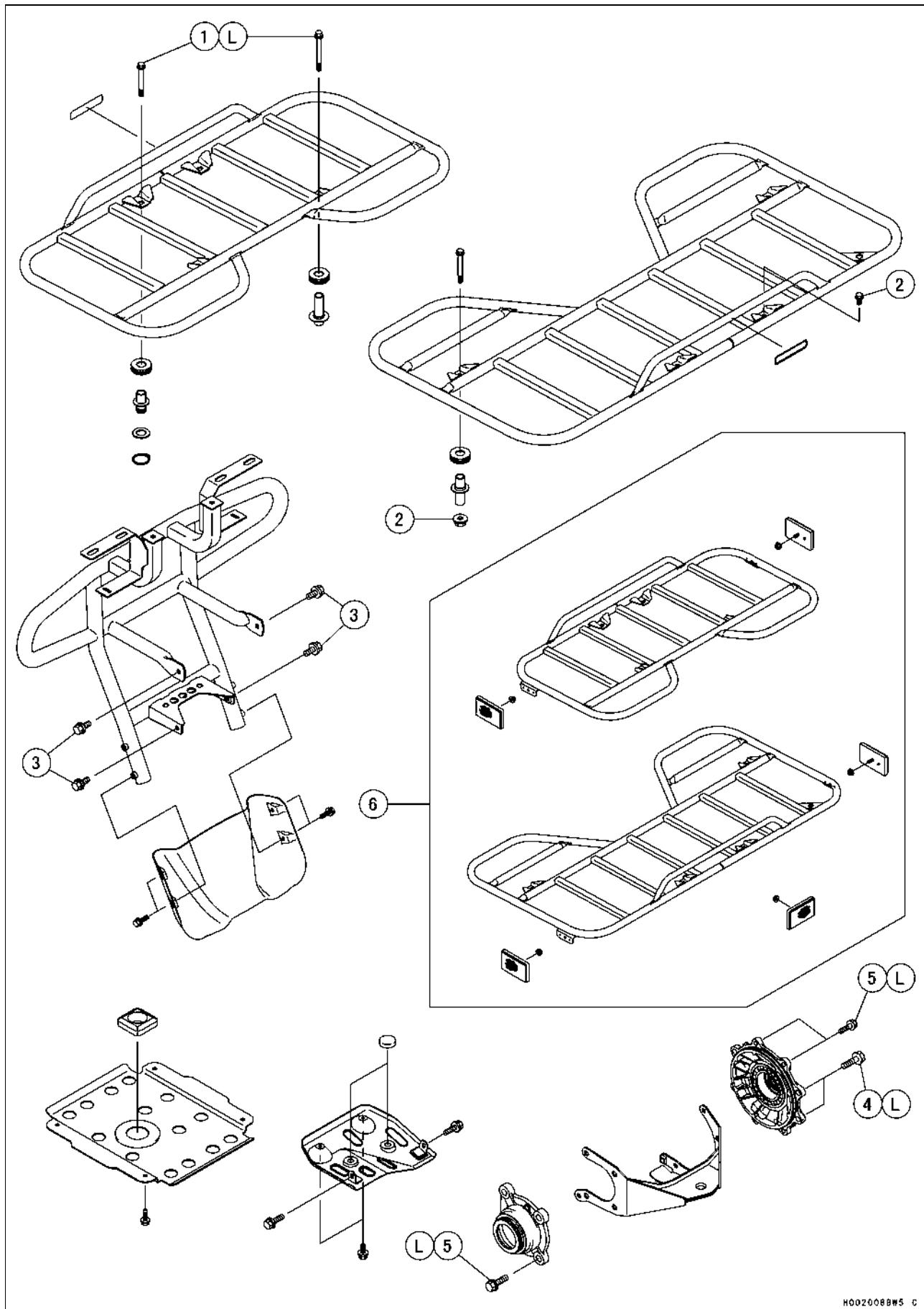

Exploded View

No.	Fastener	Torque			Remarks
		N·m	kgf·m	ft·lb	
1	Front Carrier Bolts	–	–	–	L
2	Rear Carrier Bolts and Nuts	25	2.5	18	
3	Front Guard Bolts	20	2.0	14	
4	Trailer Hitch Bracket Bolts (M10)	49	5.0	36	L
5	Trailer Hitch Bracket Bolts (M8)	24	2.4	17	L

6: Canada, United Kingdom and Europe models

L: Apply a non-permanent locking agent.

15-4 FRAME

Exploded View

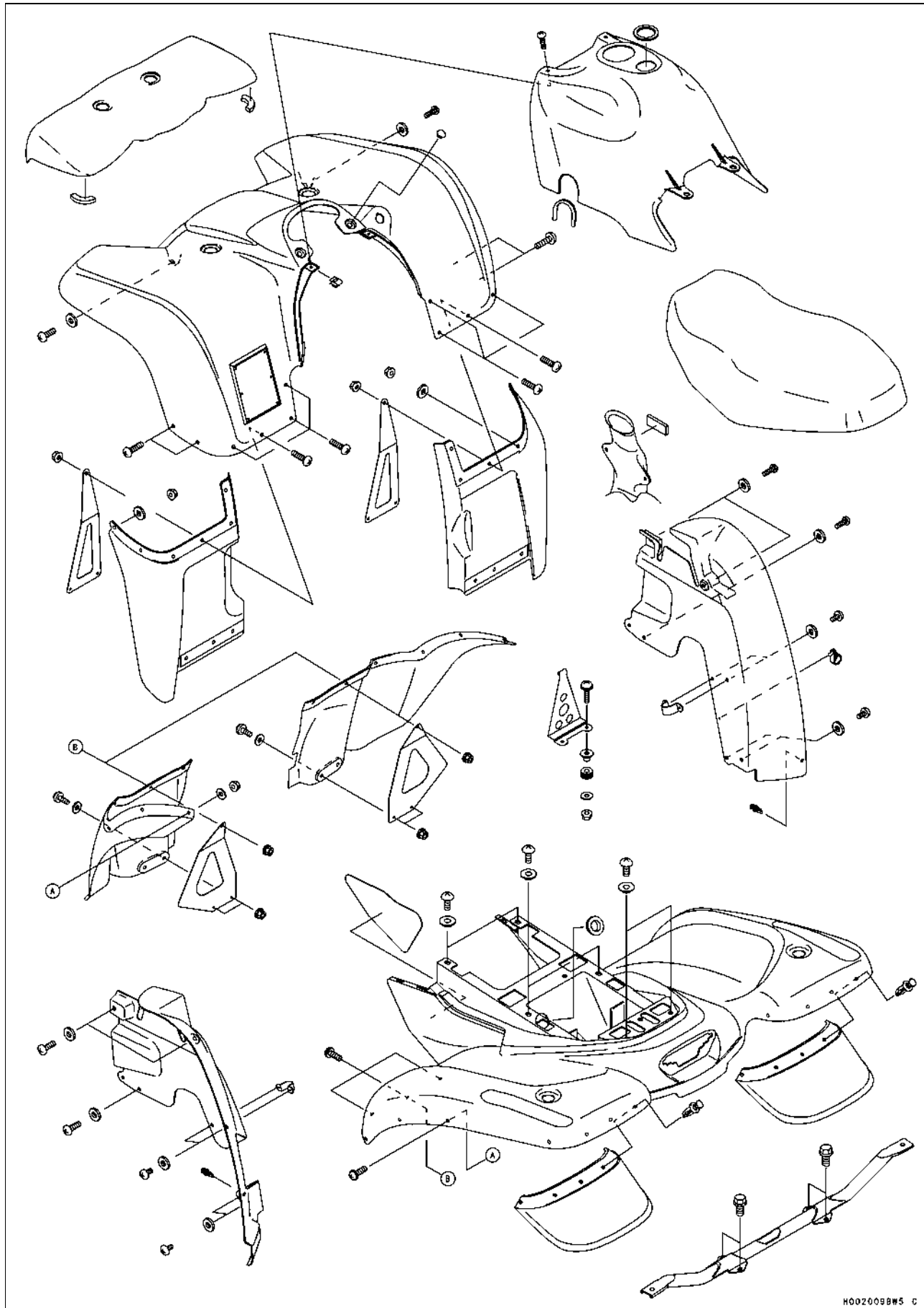

Exploded View

15-6 FRAME

Exploded View

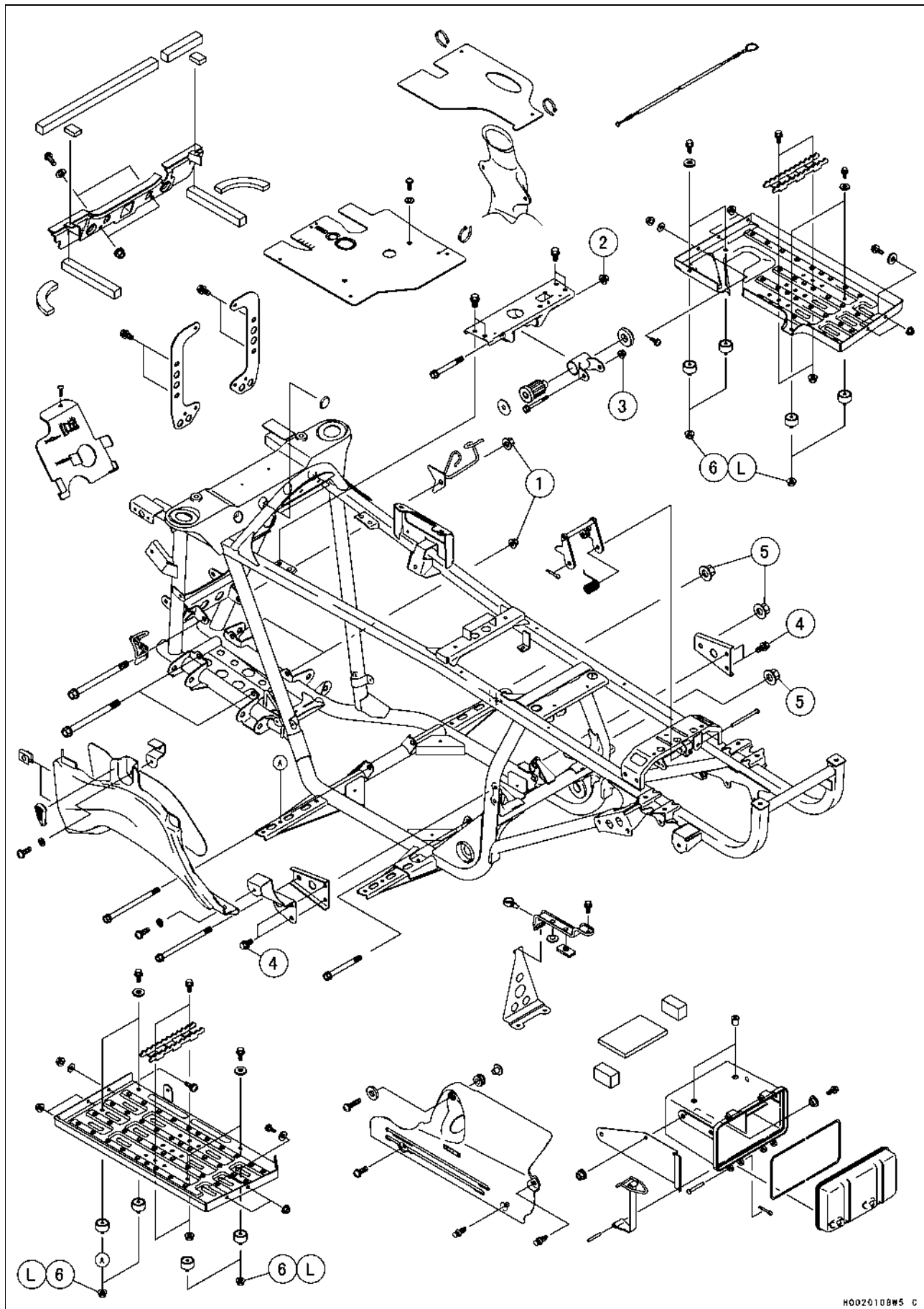

Exploded View

No.	Fastener	Torque			Remarks
		N·m	kgf·m	ft·lb	
1	Front Final Gear Case Bolts and Nuts	42	4.3	31	
2	Upper Engine Mounting Bracket Bolt and Nut	42	4.3	31	
3	Upper Engine Mounting Bolt and Nut	25	2.5	18	
4	Lower Engine Mounting Bracket Bolts	25	2.5	18	
5	Lower Engine Mounting Bolts and Nuts	42	4.3	31	
6	Footboard Mounting Nuts	–	–	–	L

L: Apply a non-permanent locking agent.

15-8 FRAME

Specifications

Special Tool - Outside Circlip Pliers: 57001-144

Seat*Seat Removal*

- Remove the seat [A] by pulling the looped seat latch [B] and then pulling the seat up to the rear.

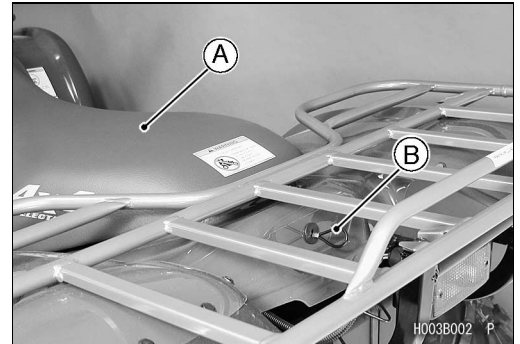
*Seat Installation*

- Slip the front seat hook [A] into the brace [B] on the frame, and put the stoppers [C] into the holes in the frame.
- Push down the rear part of the seat until the locks [D] with a click.

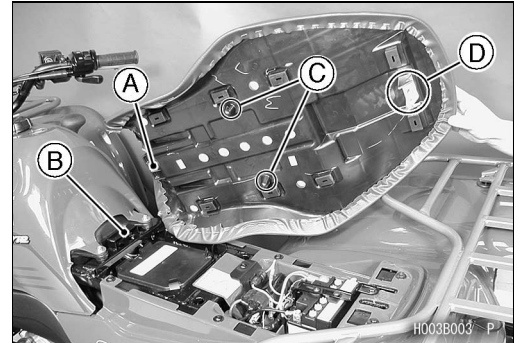

15-10 FRAME

Carriers

Front Carrier Removal

- Remove:
 - Carrier Bolts [A]
 - Front Carrier [B]
 - Collars [C]
 - Headlight Cover [D]

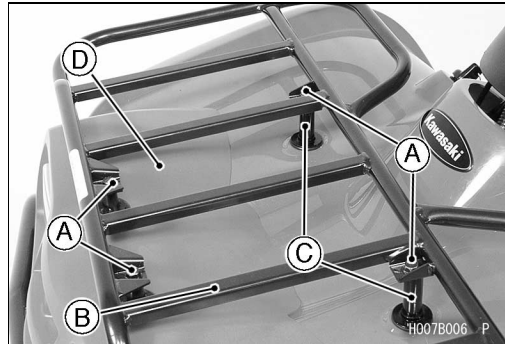

Front Carrier Installation

- Install:
 - Collars [A]

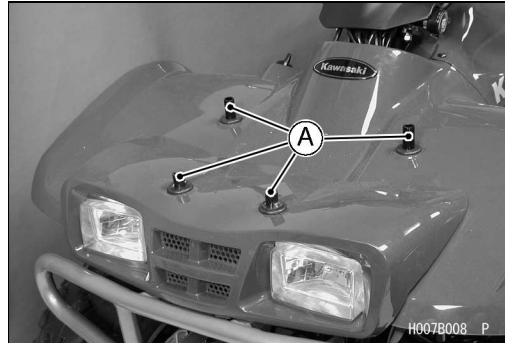

- Install:
 - Front Carrier [A]
- Apply a non-permanent locking agent:
 - Front Carrier Bolts, L = 65 mm (2.56 in.) [B]
 - Front Carrier Bolts, L = 80 mm (3.15 in.) [C]

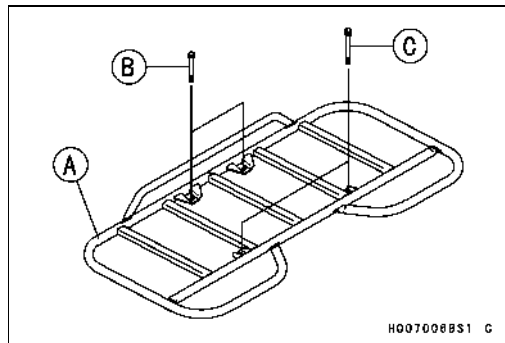

Rear Carrier Removal

- Remove:
 - Rear Carrier Bolts [A]
 - Rear Carrier [B]

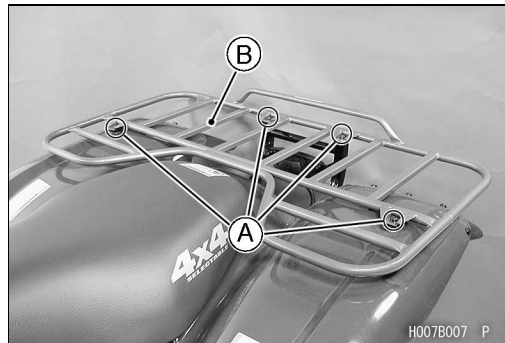

Rear Carrier Installation

- Install:
 - Damper [A]
 - Collar [B]
 - Rear Carrier

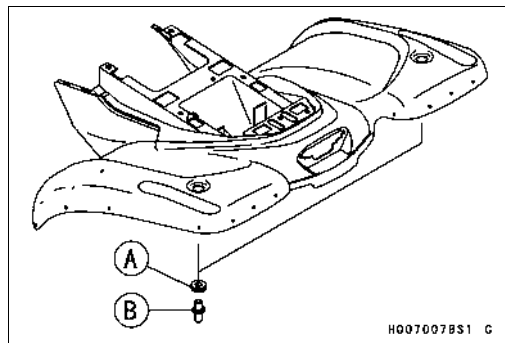

Carriers

● Tighten:

Torque - Rear Carrier Bolts [A] and Nuts [B]: 25 N·m (2.5 kgf·m, 18 ft·lb)

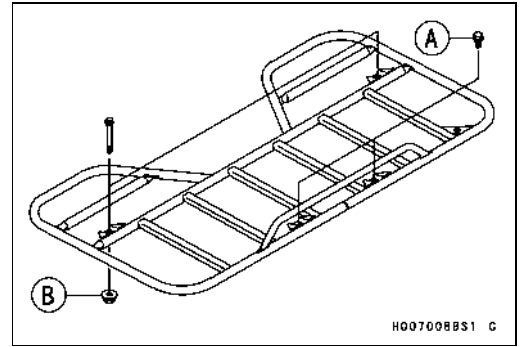

15-12 FRAME

Fenders

Front Fender Removal

- Remove:
 - Seat (see Seat Removal)
 - Fuel Tank Cover (see Fuel Tank Cover Removal)
 - Front Carrier (see Front Carrier Removal)
 - Headlight Cover (see Headlight Cover Removal)
 - Front Flap Lower Screws [A] (both sides)
 - Ignition Switch Nut [B]

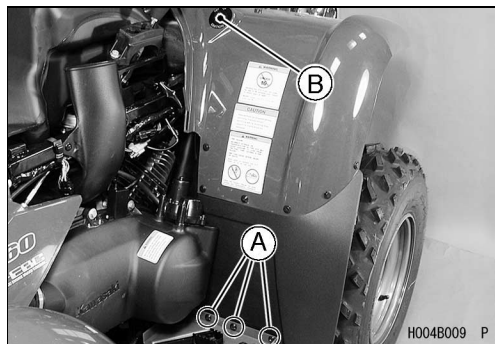

- Remove:
 - Quick Rivets [A]
 - Screws [B] and Collars (both sides)
 - Front Fender

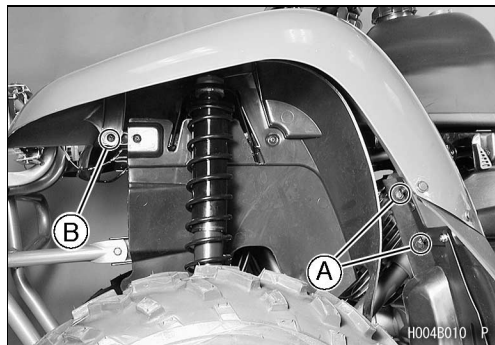

Front Fender Installation

- Install:
 - Damper [A]
 - Clamp Nuts [B]
 - Collars [C]

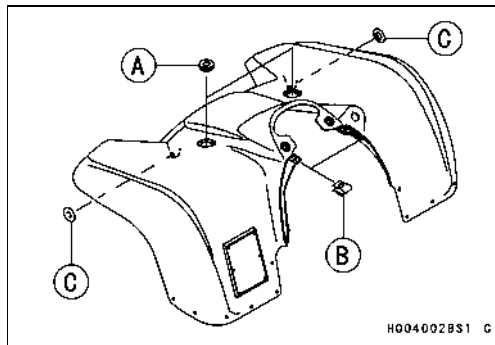

- Fit the projection [A] on the ignition switch into the recess in the front fender.
- Tighten the nut [B] securely.
- Install:
 - Headlight Cover (see Headlight Cover Installation)
 - Front Carrier (see Front Carrier Installation)

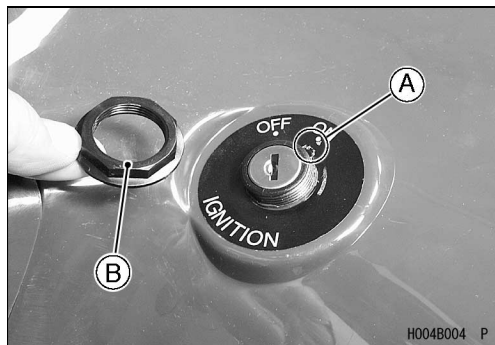

Rear Fender Removal

- Remove:
 - Seat (see Seat Removal)
 - Rear Carrier (see Rear Carrier Removal)
 - Fuel Tank Cover (see Fuel Tank Cover Removal)
 - Battery [A] (see Electrical System chapter)
 - Electrical Equipments [B] with Grommet [C]
 - Bolts [D]
 - Screws [E]

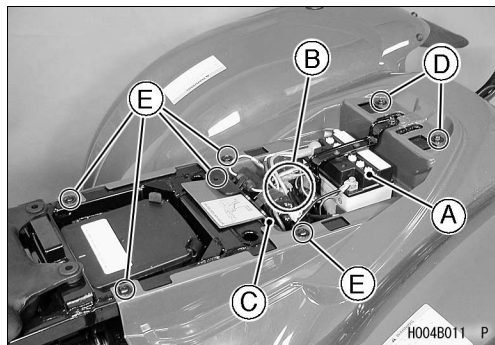

Fenders

- Remove:
 - Rear Flap Lower Screws [A] (both sides)
 - Collars
 - Rear Fender

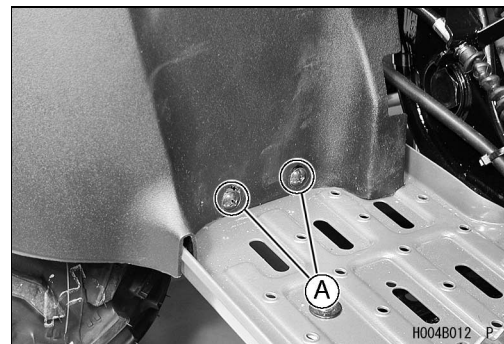

Rear Fender Installation

- Install:
 - Dampers [A]
 - Collars [B]
 - Grommet [C]
 - Rear Carrier (see Rear Carrier Installation)

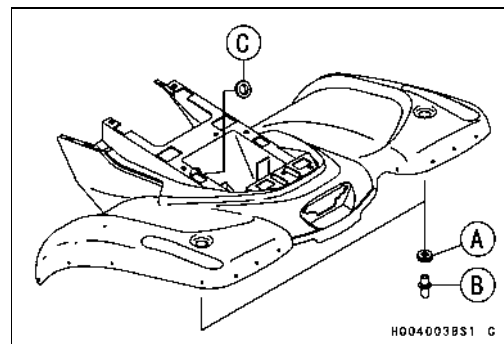

15-14 FRAME

Covers

Headlight Cover Removal

- Remove:
 - Front Carrier (see Front Carrier Removal)
 - Collars [A]
- Push up the stopper part [B] at the inside of the front guard and remove the headlight cover [C].

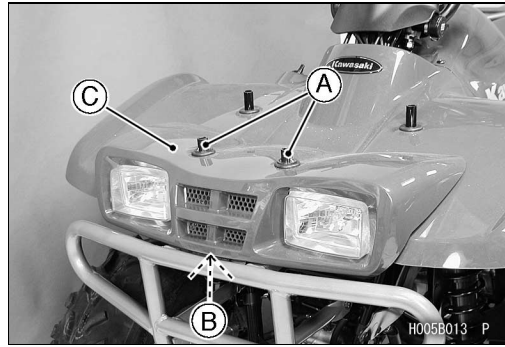

- Remove:
 - Circlip [A]
- **Special Tool - Outside Circlip Pliers [B]: 57001-144**
- Remove:
 - Collar [C]
 - Washer
 - Damper

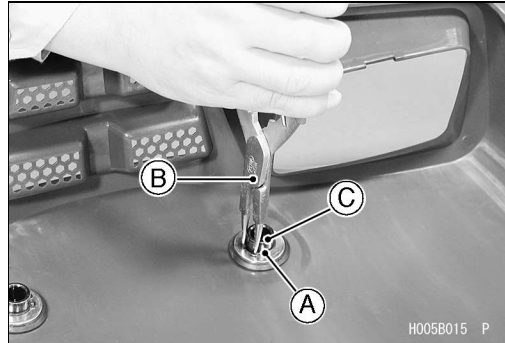

Headlight Cover Installation

- Install:
 - Damper [A]
 - Collar [B]
 - Washer [C]
 - Circlip [D]
- **Special Tool - Outside Circlip Pliers: 57001-144**

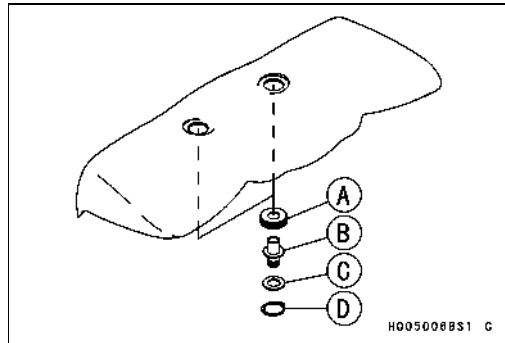

- Put the headlight cover on the headlight.
- Push the stopper [A] lightly and fit it inside the front guard [B].
- Install:
 - Rear Carrier (see Rear Carrier Installation)

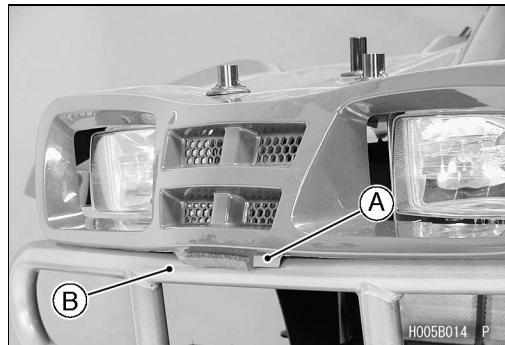

Front Inner Cover Removal

- Remove:
 - Bracket Screws [A] and Bracket
 - Screws [B] and Collar
 - Front Inner Cover [C]

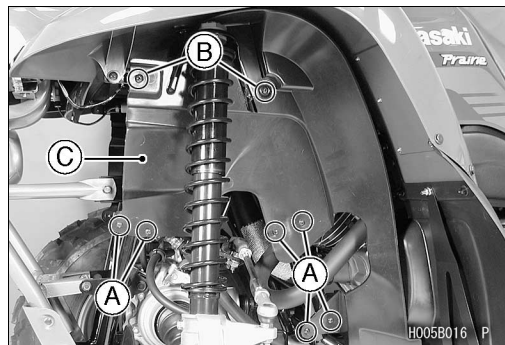

Covers

Front Inner Cover Installation

- Install:
 - Collar [A]
 - Brackets [B]

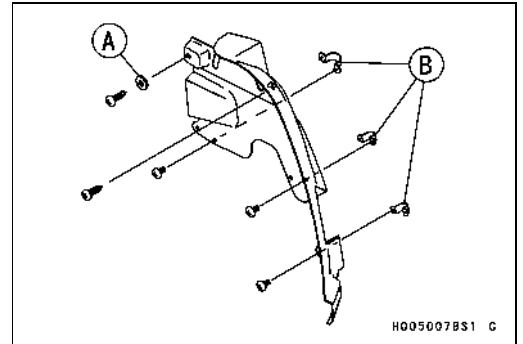

Fuel Tank Cover Removal

- Remove:
 - Seat (see Seat Removal)
 - Screws [A]
 - Bolts [B]
 - Grip [C]
 - Fuel Tank Cap [D]
 - Fuel Tank Cover [E]
- Install the fuel tank cap at once.

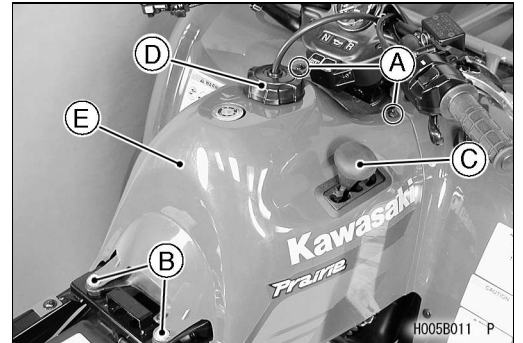

Fuel Tank Cover Installation

- Insert the tabs [A] of the cover into the recesses (both sides).



Left Side Cover Removal

- Remove:
 - Quick Rivets [A]
 - Screws [B]
 - Left Side Cover [C]

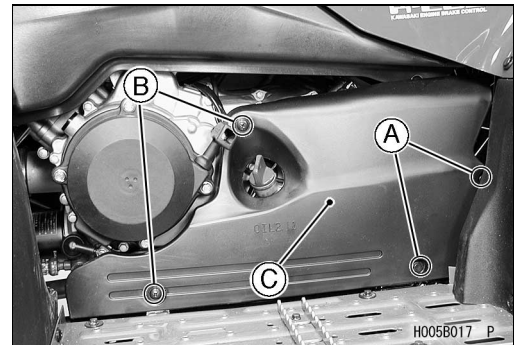

Exhaust Pipe Cover Removal

- Remove:
 - Seat (see Seat Removal)
 - Fuel Tank Cover (see Fuel Tank Cover Removal)
 - Left Side Cover (see Left Side Cover Removal)
 - Quick Rivets [A] (Front Left Flap [B])

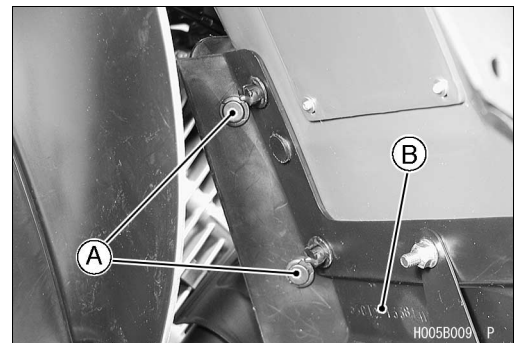

15-16 FRAME

Covers

- Remove:
 - Screws [A]
 - Exhaust Pipe Cover [B]

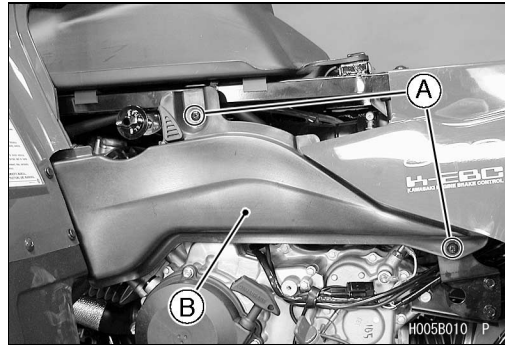

Guards

Front Guard Removal

- Remove:
 - Front Carrier (see Front Carrier Removal)
 - Headlight Cover (see Headlight Cover Removal)
 - Headlight Lead Connector [A]

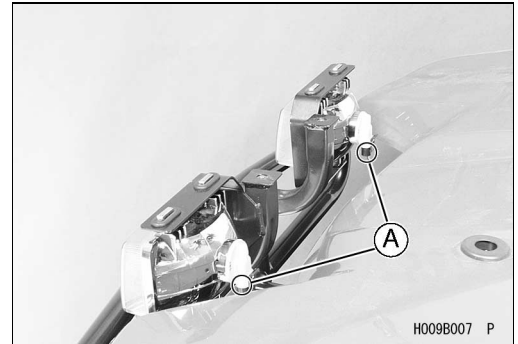

- Remove:
 - Front Guard Bolts [A]
 - Front Guard [B]

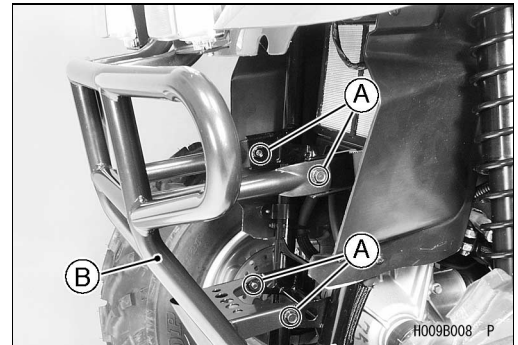

Front Lower Guard Removal

- Remove:
 - Front Lower Guard Bolts [A]
 - Front Lower Guard [B]

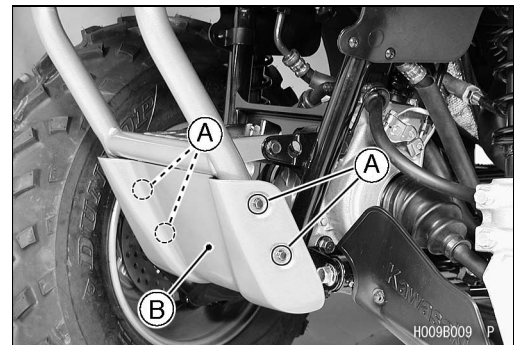

Front Guards Installation

- Install:
 - Front Guard [A]
- Tighten:
 - Torque - Front Guard Bolts [B]: 20 N·m (2.0 kgf·m, 14 ft·lb)**
- Install:
 - Front Lower Guard [C]
 - Front Lower Guard Bolts [D]

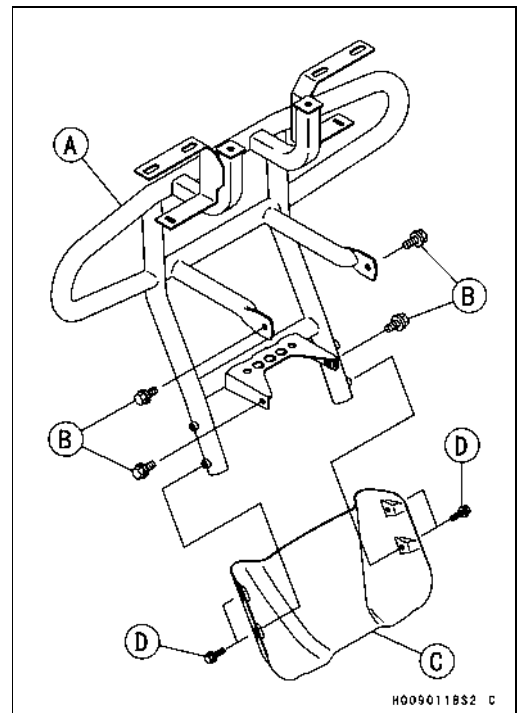

15-18 FRAME

Guards

Engine Bottom Guard Removal

- Remove:
 - Bolts [A]
 - Engine Bottom Guard

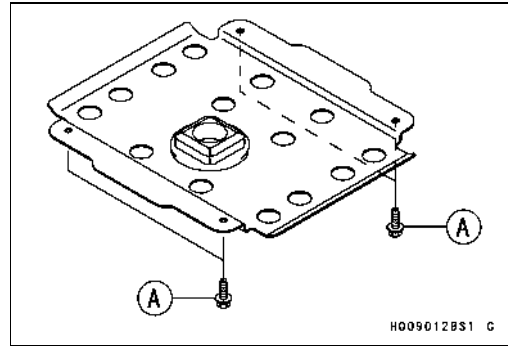

Engine Bottom Guard Installation

- Confirm:
 - Damper [A]
- Install:
 - Engine Bottom Guard [B]
 - Bolts

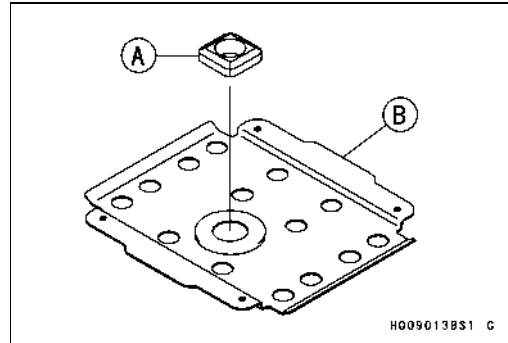

Rear Bottom Guard Removal

- Remove:
 - Bolts (M6) [A]
 - Bolts (M8) [B]
 - Rear Bottom Guard [C]

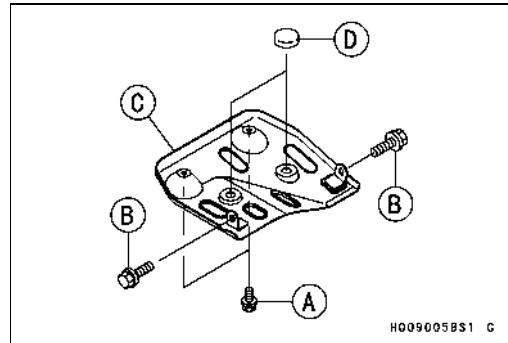

Rear Bottom Guard Installation

- Confirm:
 - Dampers [D]
- Install:
 - Rear Bottom Guards
 - Bolts (M8)
 - Bolts (M6)

Flaps and Footboards

Front Flap Removal

- Remove:
 - Quick Rivets [A]
 - Screws [B], Washers, and Nuts
 - Front Flap [C] and Flap Holder Plate

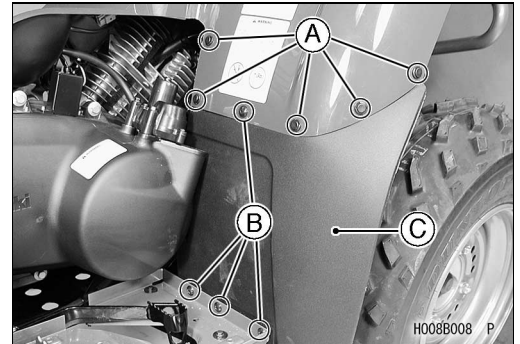

Front Flap Installation

- Install:
 - Front Flap [A]
 - Flap Holder Plate [B]
 - Screws, L=22 mm (0.87 in.) [C], Washers, and Nuts
 - Quick Rivet [D]
 - Screws, L=16 mm (0.63 in.) [E]

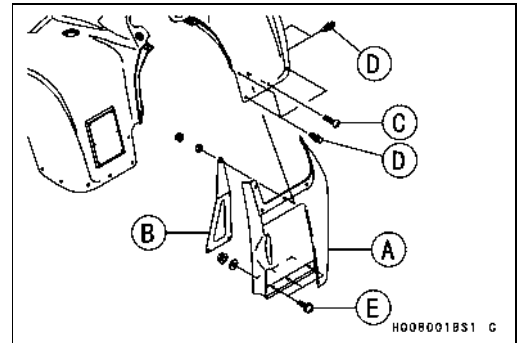

Rear Flap Removal

- Remove:
 - Quick Rivets [A]
 - Screws [B], Washers, and Nuts
 - Rear Flap [C] and Flap Holder Plate

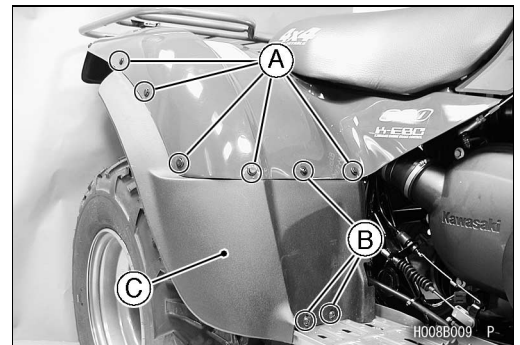

Rear Flap Installation

- Install:
 - Rear Flap [A]
 - Flap Holder Plate [B]
 - Screws [C], Washers, and Nuts
 - Quick Rivet [D]

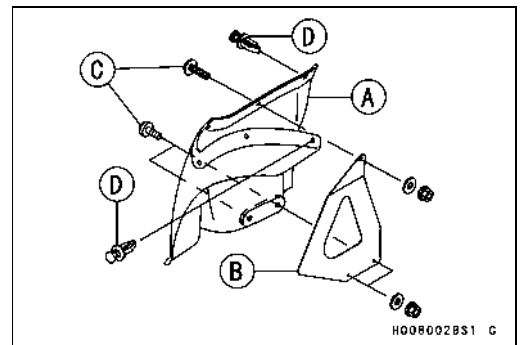

Footboard Removal

- Remove:
 - Screws [A], Washer, and Nut

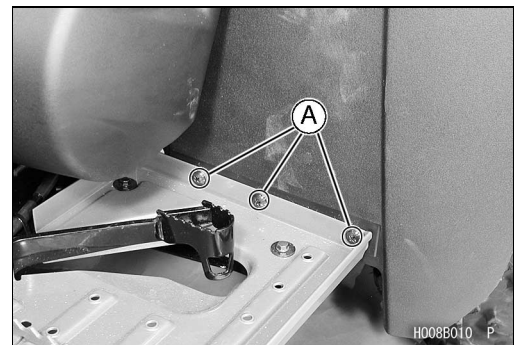

15-20 FRAME

Flaps and Footboards

- Remove:
Screws [A]

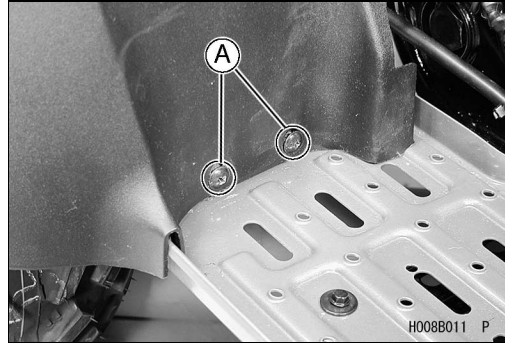

- Remove:
Bolts [A]
Footboard [B]

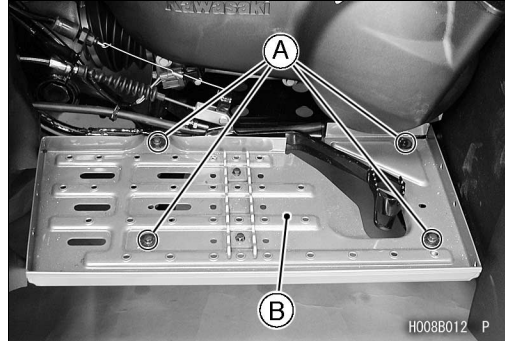

Footboard Installation

- Be sure the dampers [A] is in place.

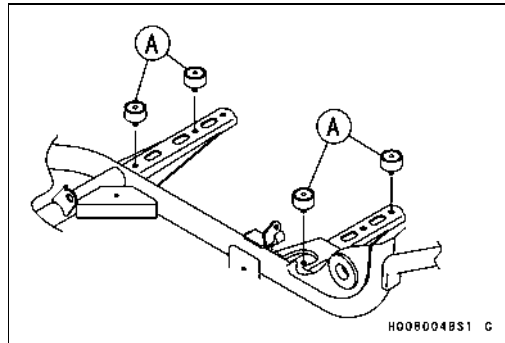

- Confirm:
Footrest [A]
Center Holes of Three Holes [B] (both side)
Bolts [C] and Nuts [D]
- Install:
Footboard
Bolts
Screws, Washers, and Nuts
- Apply a non-permanent locking agent to the footboard mounting nuts.

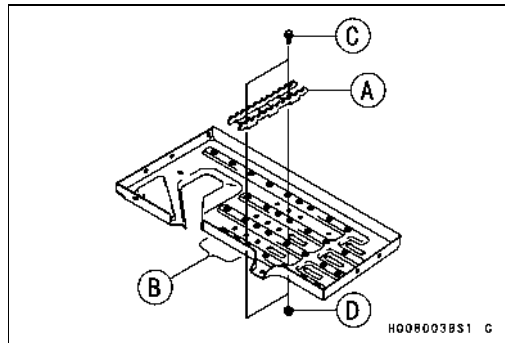

Trailer Hitch Bracket

Trailer Hitch Bracket Removal

- Drain:
 - Rear Final Gear case Oil (see Rear Final Gear Case Oil Change section in Final Drive chapter)
- Remove:
 - Rear Bottom Guard (see Rear Bottom Guard Removal)
 - Trailer Hitch Bracket Bolts (M8) [A]

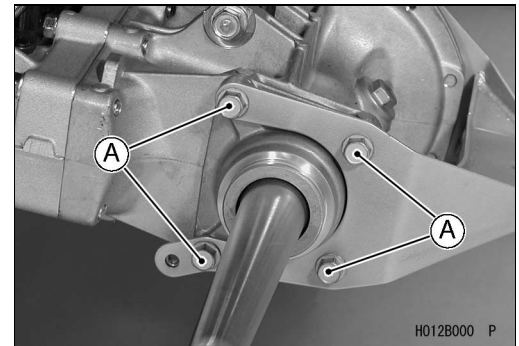

- Remove:
 - Trailer Hitch Bracket Bolts [A]
 - Trailer Hitch Bracket [B]

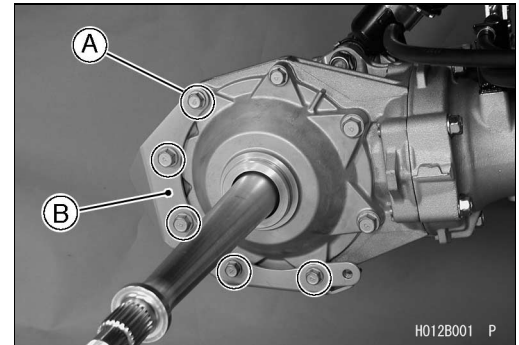

Trailer Hitch Bracket Installation

- Install:
 - Rear Final Gear Case Left Cover [A] (see Rear Axle Installation section in Final Drive chapter)
 - Trailer Hitch Bracket [B]
- Apply a non-permanent locking agent to the trailer hitch bracket bolts.
- Tighten:
 - Torque - Trailer Hitch Bracket Bolts (M10) [C]: 49 N·m (5.0 kgf·m, 36 ft·lb)**
 - Trailer Hitch Bracket Bolts (M8) [D]: 24 N·m (2.4 kgf·m, 17 ft·lb)**

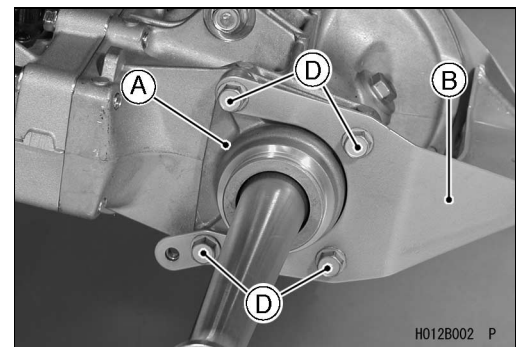

- Install:
 - Rear Bottom Guard (see Rear Bottom Guard Installation)
- Fill the final gear case up to the bottom of filler opening with the specified oil (see Rear Final Gear Case Oil Change section in Final Drive chapter).

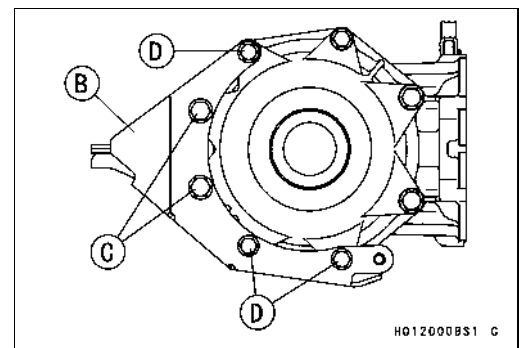

Electrical System

Table of Contents

Precautions.....	16-3	Starter Motor Brush Length.....	16-35
Exploded View.....	16-4	Brush Assembly Inspection.....	16-35
Specifications.....	16-10	Brush Plate and Terminal Bolt Inspection.....	16-35
Parts Location.....	16-11	Starter Relay Inspection.....	16-36
Electrical Wiring.....	16-13	Starter Circuit Relay Inspection.....	16-36
Wiring Inspection.....	16-13	Starter Motor Clutch Removal.....	16-37
Battery.....	16-14	Starter Motor Clutch Installation.....	16-38
Battery Removal.....	16-14	Starter Motor Clutch Inspection.....	16-38
Battery Installation.....	16-14	Torque Limiter Inspection.....	16-38
Electrolyte Level Inspection.....	16-14	Lighting System.....	16-39
Electrolyte Specific Gravity Inspection.....	16-14	Headlight Beam Vertical Adjustment.....	16-39
Initial Charging.....	16-15	Headlight Bulb Replacement.....	16-39
Ordinary Charging.....	16-16	Headlight Body Removal.....	16-40
Battery Test Charging.....	16-17	Headlight Body Installation.....	16-40
Charging System.....	16-18	Taillight Bulb Replacement.....	16-40
Alternator Cover Removal.....	16-18	Oil Cooler Fan System.....	16-43
Alternator Cover Installation.....	16-18	Oil Cooler Fan Circuit Inspection.....	16-43
Alternator Rotor Removal.....	16-19	Oil Cooler Fan Motor Inspection.....	16-43
Alternator Rotor Installation.....	16-20	Speedometer (Optional Part for U.S. model).....	16-44
Alternator Stator Removal.....	16-20	Speedometer Removal.....	16-44
Alternator Stator Installation.....	16-21	Speedometer Inspection.....	16-44
Regulator/Rectifier Output Voltage Inspection.....	16-21	LED Indicator.....	16-47
Alternator Inspection.....	16-21	Drive Belt Failure Mode Memory Clearing Procedure.....	16-47
Regulator/Rectifier Inspection.....	16-22	LED Indicator Removal.....	16-48
Ignition System.....	16-25	LED Indicator Installation.....	16-48
Spark Plug Removal.....	16-25	LED Indicator Inspection.....	16-48
Spark Plug Installation.....	16-25	Actuator Control System.....	16-53
Spark Plug Cleaning / Inspection.....	16-25	2WD/4WD Actuator Removal.....	16-53
Spark Plug Gap Inspection.....	16-25	2WD/4WD Actuator Installation.....	16-53
Ignition Coil Removal.....	16-26	Engine Brake Actuator Removal.....	16-53
Ignition Coil Installation.....	16-26	Engine Brake Actuator Installation.....	16-54
Ignition Coil Inspection.....	16-26	Actuator Control System Outline.....	16-54
Ignition Coil Primary Peak Voltage Inspection.....	16-27	Actuator Control System Troubleshooting.....	16-56
Pickup Coil Removal.....	16-27	Drive Belt Failure Detection System.....	16-64
Pickup Coil Installation.....	16-28	Drive Belt Failure Detection System Inspection.....	16-64
Pickup Coil Inspection.....	16-28	Carburetor Heater System.....	16-67
Pickup Coil Peak Voltage Inspection.....	16-28	Air Temperature Sensor Inspection.....	16-67
Alternator Rotor Inspection.....	16-29	Carburetor Heater Inspection.....	16-68
Ignition Timing Test.....	16-29	Switches.....	16-69
Electric Starter System.....	16-32	Brake Light Switch Adjustment.....	16-69
Starter Motor Removal.....	16-32	Oil Cooler Fan Switch Inspection.....	16-69
Starter Motor Installation.....	16-32	Oil Temperature Warning Light Switch Inspection.....	16-69
Starter Motor Disassembly.....	16-32	Switch Inspection.....	16-69
Starter Motor Assembly.....	16-33	Drive Belt Failure Detection Switch.....	16-70
Commutator Cleaning/Inspection.....	16-34		
Armature Inspection.....	16-35		

16-2 ELECTRICAL SYSTEM

Fuses.....	16-71	Wiring Diagram	16-72
Fuses Removal.....	16-71		
Fuse Inspection.....	16-71		

Precautions

There are a number of important precautions that should be taken when servicing electrical systems. Learn and observe all the rules below.

- Do not reverse the battery lead connections. This will burn out the diodes in the electrical parts.
- Always check battery condition before condemning other parts of an electrical system. A fully charged battery is required for conducting accurate electrical system tests.
- The electrical parts should never be struck sharply, as with a hammer, or allowed to fall on a hard surface. Such a shock to the parts can damage them.
- To prevent damaging electrical parts, do not disconnect the battery leads or any other electrical connections when the ignition switch is on, or while the engine is running.
- Because of the high current, never keep the starter button depressed when the starter motor will not turn over, or the current may burn out the starter motor windings.
- Only use an illumination bulb rated for the voltage or wattage specified in the wiring diagram, or the handle cover could be warped by excessive heat radiated from the bulb.
- Take care not to short the leads that are directly connected to the battery positive (+) terminal to chassis ground.
- Troubles may involve one or in some cases all items. Never replace a defective part without determining what CAUSED the failure. If the failure was caused by some other item or items, they too must be repaired or replaced, or the new replacement will soon fail again.
- Make sure all connectors in the circuit are clean and tight, and examine wires for signs of burning, fraying, etc. Defective wires and bad connections will affect electrical system operation.
- Measure coil and winding resistance when the part is cold (at room temperature).
- Color Codes:

BK	Black	G	Green	P	Pink
BL	Blue	GY	Gray	PU	Purple
BR	Brown	LB	Light blue	R	Red
CH	Chocolate	LG	Light green	W	White
DG	Dark green	O	Orange	Y	Yellow

- Electrical Connectors:
Female Connectors [A]

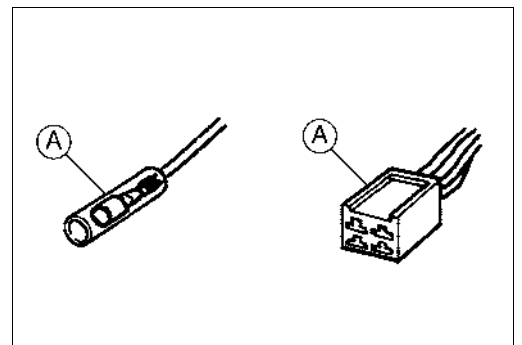

- Male Connectors [B]

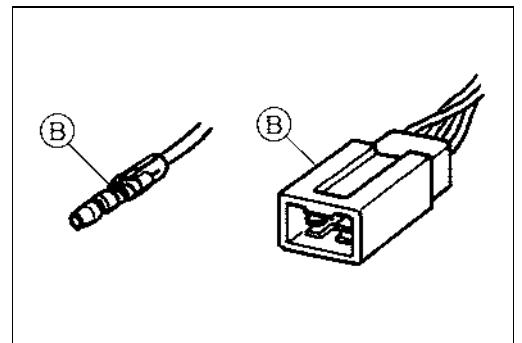

16-4 ELECTRICAL SYSTEM

Exploded View

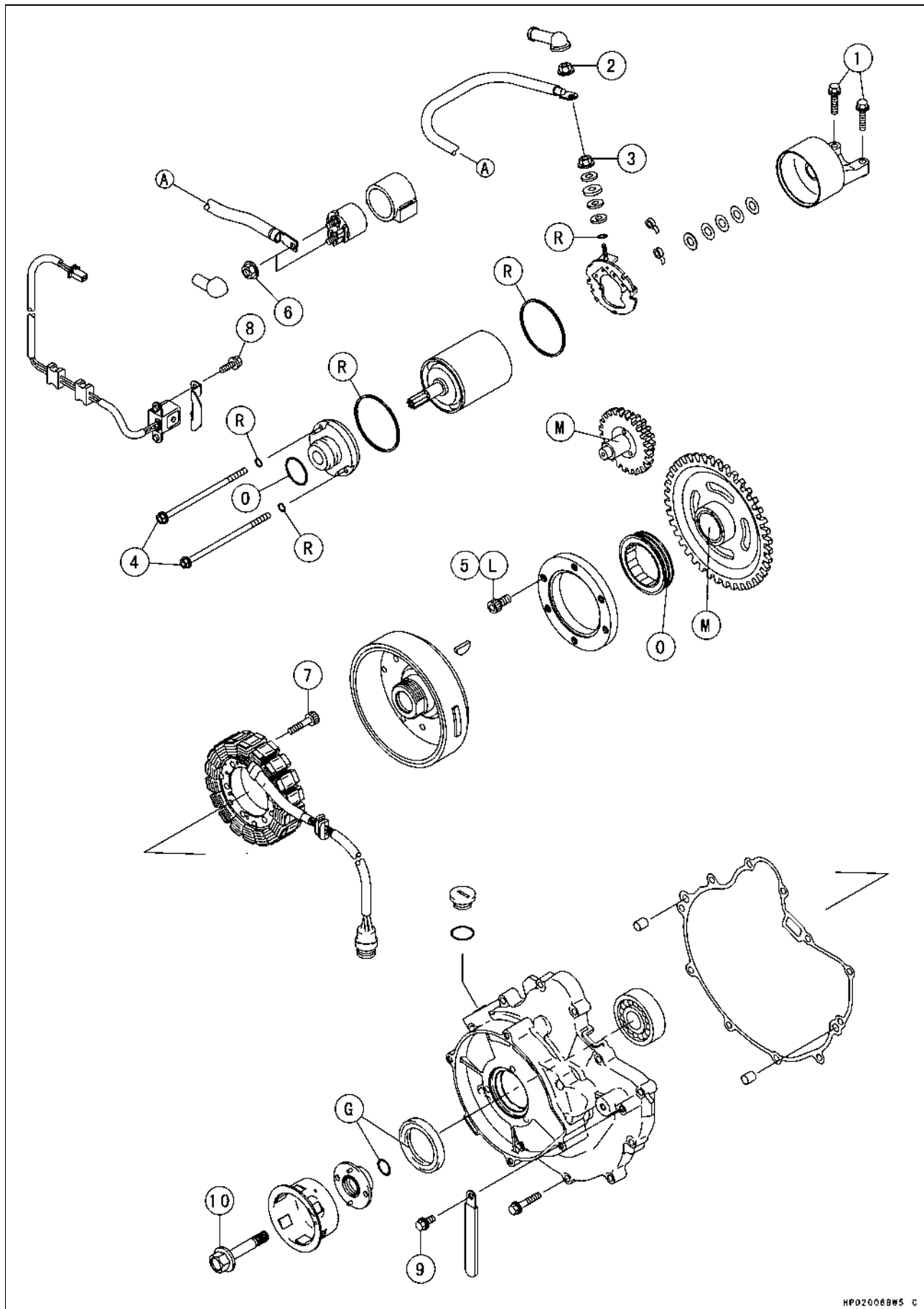

Exploded View

No.	Fastener	Torque			Remarks
		N·m	kgf·m	ft·lb	
1	Starter Motor Mounting Bolts	8.8	0.9	78 in·lb	
2	Starter Motor Terminal Nut	4.9	0.5	43 in·lb	
3	Starter Motor Terminal Locknut	6.9	0.7	61 in·lb	
4	Starter Motor Bolts	3.4	0.3	30 in·lb	
5	Starter Motor Clutch Bolts	34	3.5	25	L
6	Starter Relay Terminal Nuts	4.9	0.5	43 in·lb	
7	Alternator Stator Bolts	14	1.4	10	
8	Pickup Coil Mounting Bolts	5.9	0.6	52 in·lb	
9	Alternator Cover Bolts	8.8	0.9	78 in·lb	
10	Alternator Rotor Bolt	127	13	94	

G: Apply grease for oil seal and O-ring.

L: Apply a non-permanent locking agent.

M: Apply molybdenum disulfide grease.

O: Apply engine oil.

R: Replacement Parts

16-6 ELECTRICAL SYSTEM

Exploded View

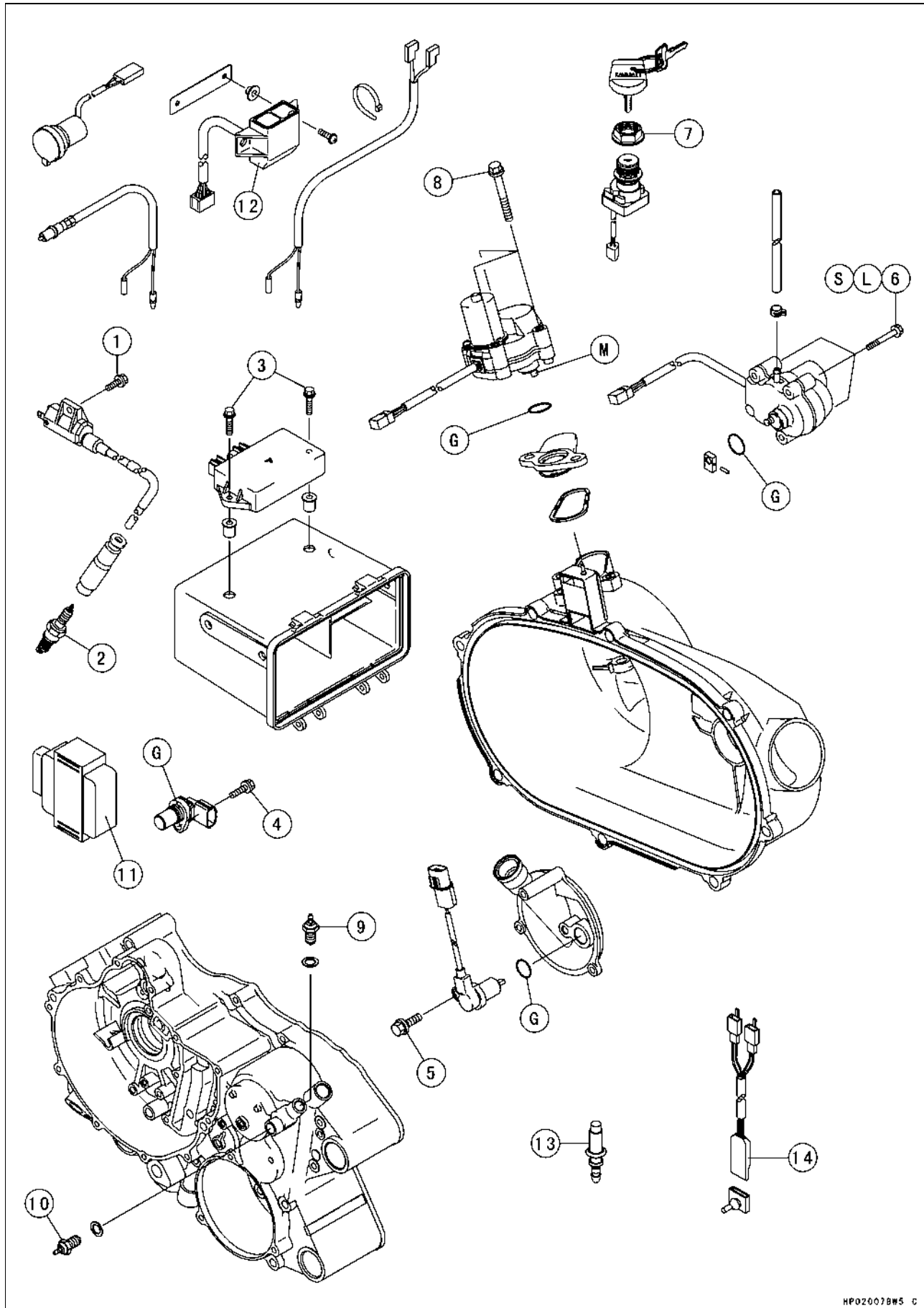

Exploded View

No.	Fastener	Torque			Remarks
		N·m	kgf·m	ft·lb	
1	Ignition Coil Mounting Bolt	8.8	0.9	78 in·lb	
2	Spark Plug	14	1.4	10	
3	Igniter Mounting Bolts	2.3	0.23	20 in·lb	
4	Speed Sensor Mounting Bolt	8.8	0.9	78 in·lb	
5	Forward/Reverse Detecting Sensor Mounting Bolts	15	1.5	11	
6	2WD/4WD Actuator Mounting Bolts	9.8	1.0	87 in·lb	L, S
7	Ignition Switch Nut	2.7	0.28	24 in·lb	
8	Engine Brake Actuator Mounting Bolts	8.8	0.9	78 in·lb	
9	Neutral Position Switch	15	1.5	11	
10	Reverse Position Switch	15	1.5	11	

- 11. Actuator Controller
- 12. LED Indicator
- 13. Carburetor Heater
- 14. Air Temperature Sensor

G: Apply grease for oil seal and O-ring.
 L: Apply a non-permanent locking agent.
 S: Follow the specific tightening sequence.
 M: Apply molybdenum disulfide grease.

16-8 ELECTRICAL SYSTEM

Exploded View

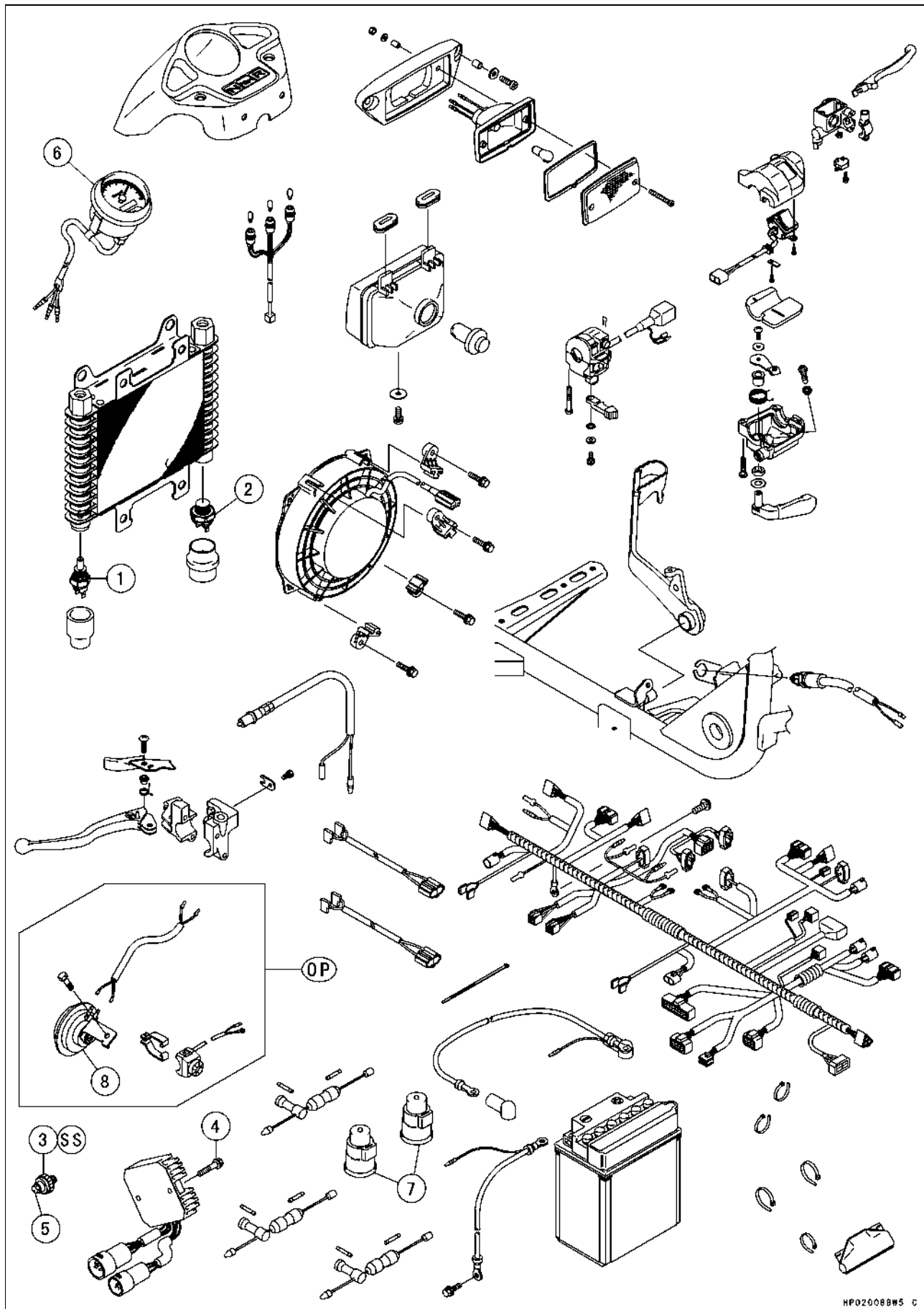

ELECTRICAL SYSTEM 16-9

Exploded View

No.	Fastener	Torque			Remarks
		N·m	kgf·m	ft·lb	
1	Oil Cooler Fan Switch	16	1.6	12	
2	Oil Temperature Warning Light Switch	16	1.6	12	
3	Oil Pressure Switch	15	1.5	11	SS
4	Regulator/Rectifier Mounting Bolts	8.8	0.9	78 in·lb	
5	Oil Pressure Switch Terminal Bolt	1.5	0.15	13 in·lb	

6: Speedometer (other than U.S.A. model)

7: Starter Circuit Relays

8: Horn (other than U.S.A. and Canada models)

SS: Apply silicone sealant (Kawasaki Bond: 56019-120).

OP: Optional Parts for U.S.A. and Canada models

16-10 ELECTRICAL SYSTEM

Specifications

Item	Standard	Service Limit
Battery:		
Capacity	12 V 14 Ah	---
Electrolyte level	Between upper and lower levels	---
Specific gravity of electrolyte	1.270 @20°C (68°F)	---
Charging System:		
Alternator type	Three-phase AC	---
Charging voltage (Regulator/rectifier output voltage)	14 ~ 15 V	---
Alternator output voltage	36 ~ 54 V 3 000 r/min (rpm)	---
Stator coil resistance	0.33 ~ 0.49 Ω	---
Ignition System:		
Spark plug:		
Spark plug gap	0.8 ~ 0.9 mm (0.031 ~ 0.035 in.)	---
Spark plug cap resistance	3.75 ~ 6.25 kΩ	---
Ignition coil:		
3 needle arcing distance	7 mm (0.28 in.) or more	---
Primary winding resistance	0.09 ~ 0.13 Ω	---
Secondary winding resistance	3.8 ~ 5.8 kΩ	---
Primary peak voltage	100 V or more	---
Pickup coil resistance	110 ~ 140 Ω	---
Pickup coil peak voltage	3.6 V or more	---
Electric Starter System:		
Starter motor:		
Commutator diameter	28 mm (1.10 in.)	27 mm (1.06 in.)
Brush length	10 mm (0.39 in.)	3.5 mm (0.14 in.)
Switches:		
Brake light switch timing	ON after 10 mm (0.4 in.) of pedal travel	---
Oil cooler fan switch resistance:		
Rising temperature	From OFF to ON at 67 ~ 73°C (153 ~ 163°F)	---
Falling temperature	From ON to OFF at 57 ~ 63°C (135 ~ 145°F)	---
	ON: Less than 0.5 Ω OFF: More than 1 MΩ	
Oil temperature warning light switch resistance:		
Rising temperature	From OFF to ON at 107 ~ 113°C (225 ~ 235°F)	---
Falling temperature	From ON to OFF at 97 ~ 103°C (207 ~ 217°F)	---
	ON: Less than 0.5 Ω OFF: More than 1 MΩ	

Special Tools - Timing Light : 57001-1241

Flywheel Holder: 57001-1313

Hand Tester: 57001-1394

Flywheel Puller : 57001-1405

Needle Adapter Set: 57001-1457

Drive Pulley Holder: 57001-1520

Parts Location

Light/Dimmer Switch [A]
 Engine Stop Switch [B]
 Starter Button [C]
 Reverse Power Assist Switch (Override) [D]
 Rear Brake Light Switch [E]
 Power Outlet Connector [F]
 2WD/4WD Shift Switch [G]
 Front Brake Light Switch [H]
 Ignition Switch [I]

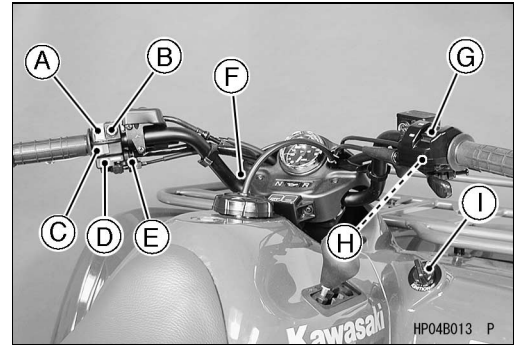

Speedometer [A] (except US model)
 Neutral Indicator Light [B]
 Oil Pressure and Temperature Warning Indicator Light [C]
 Reverse Indicator Light [D]
 Drive Belt Check Indicator Light (LED) [E]
 "4WD" Indicator Light (LED) [F]

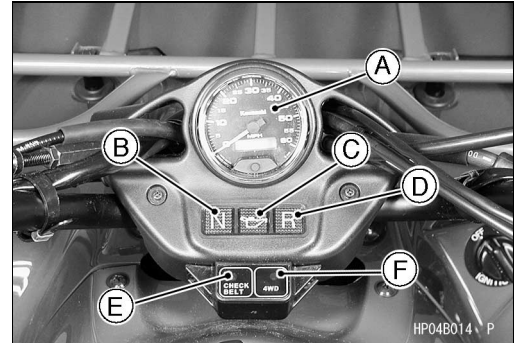

Headlights [A]
 Fan Fuses 20A and Belt Switch Fuse 5A [B]

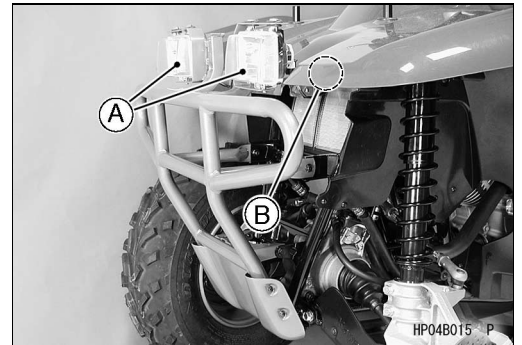

Ground Wire (Frame) [A]
 Ignition Coil [B]
 Oil Cooler Fan [C]
 Spark Plug [D]
 2WD/4WD Actuator [E]

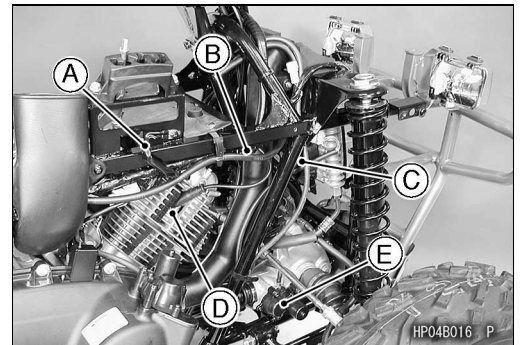

Drive Belt Failure Detection Switch [A]
 Carburetor Heater and Ground Terminals [B]
 Drive Belt Failure Mode Reset Connectors [C]
 Engine Brake Actuator [D]
 Rear Brake Light Switch [E]
 Speed Sensor [F]

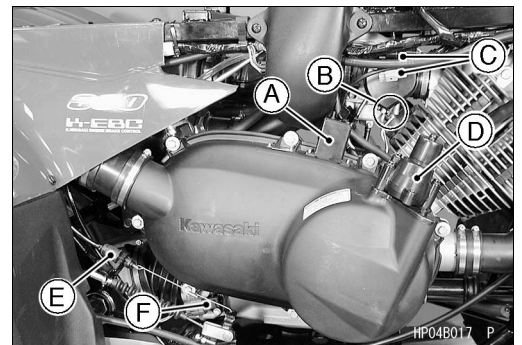

16-12 ELECTRICAL SYSTEM

Parts Location

- Alternator [A]
- Starter Motor [B]
- Pickup Coil [C]
- Reverse Position Switch [D]
- Neutral Position Switch [E]
- Ground Wire (Engine) [F]
- Forward/Reverse Detecting Sensor [G]
- Oil Pressure Warning Light Switch [H]

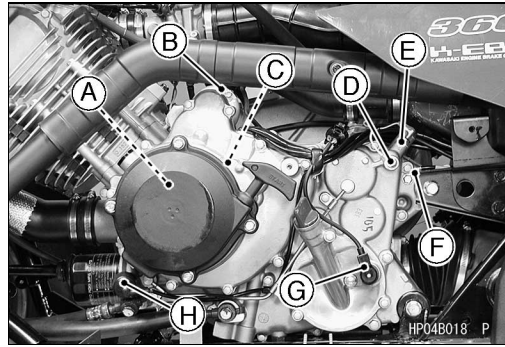

- Battery [A]
- Accessory Fuse 5A [B]
- Air Temperature Sensor [C]
- Starter Circuit Relay (Neutral) [D]
- Starter Relay [E]
- Starter Circuit Relay (Brake) [F]
- Actuator Controller [G]
- Main Fuse 30 A [H]

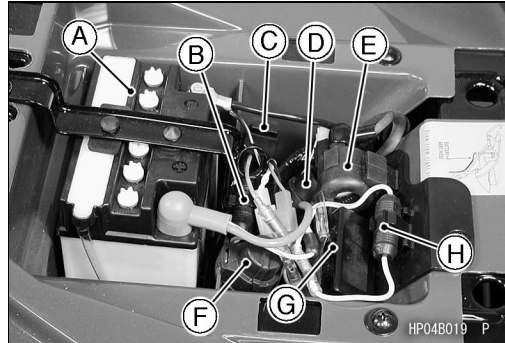

- Tail/Brake Light [A]
- Igniter [B]
- Regulator/Rectifier [C]

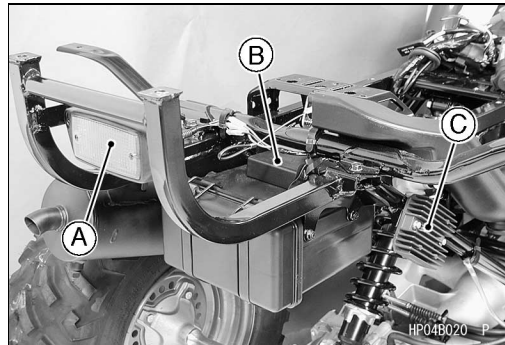

- Oil Temperature Switch [A]
- Oil Cooler Fan Switch [B]

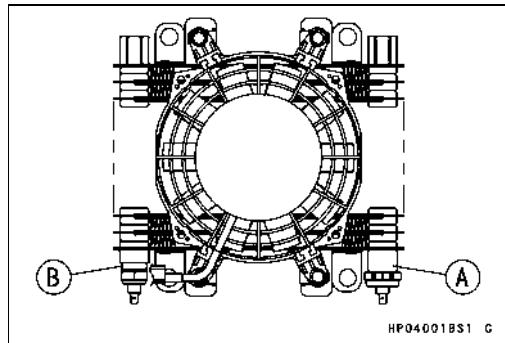

Electrical Wiring

Wiring Inspection

- Visually inspect the wiring for signs of burning, fraying, etc.
- ★ If any wiring is defective, replace the damaged wiring.
- Pull each connector [A] apart and inspect for corrosion, dirt, and damage.
- ★ If the connector is corroded or dirty, clean it carefully. If it is damaged, replace it.
- Check the wiring for continuity.
- Use the wiring diagram to find the ends of the lead which is suspected of being a problem.
- Connect the hand tester between the ends of the leads.

Special Tool - Hand Tester: 57001-1394

- Set the tester to the x 1 Ω range.
- ★ If the tester does not read 0 Ω , the lead is defective. Replace the lead or the wiring harness [B] if necessary.

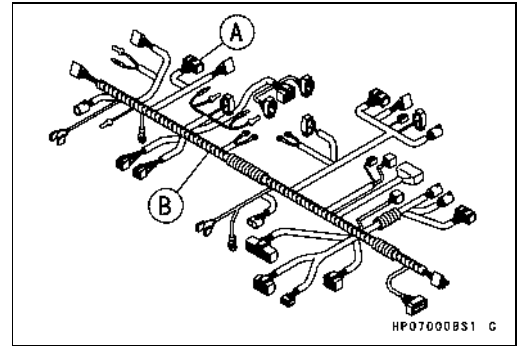

16-14 ELECTRICAL SYSTEM

Battery

Battery Removal

- Remove:
 - Seat (see Frame chapter)
- Disconnect the battery negative (-) cable [A] first, and then the positive (+) cable [B].
- Remove:
 - Battery Holder Bolt [C]
 - Battery Holder [D]
- Take out the battery [E].

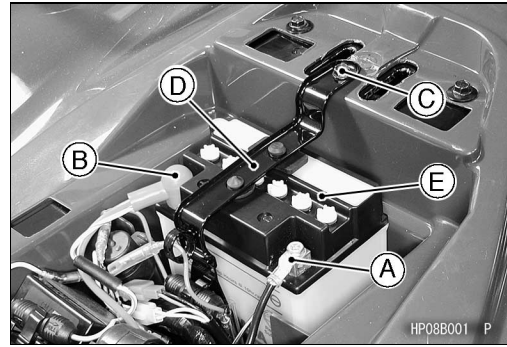

Battery Installation

- Connect the positive cable first and then the negative cable.
- Put a light coat of grease on the terminals to prevent corrosion.
- Route the battery vent hose according to the Cable, Wire, and Hose Routing section in Appendix chapter.

Electrolyte Level Inspection

- The electrolyte level should be between the upper and lower level lines [A].
- ★ If the level of electrolyte in any cell is below the lower level line, add only distilled water to the cell, until the level is at the upper level line.

CAUTION

Ordinary tap water is not a substitute for distilled water and will shorten the life of the battery.

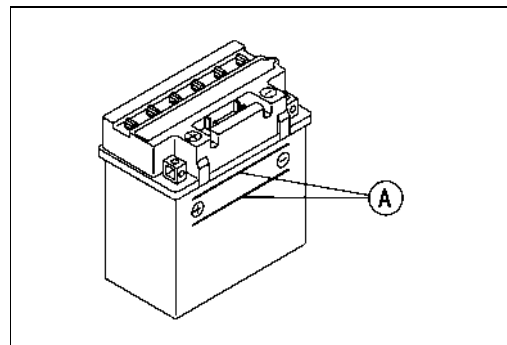

Electrolyte Specific Gravity Inspection

- Check battery condition by testing the specific gravity of the electrolyte in each cell with a hydrometer.
- Read the level of the electrolyte [A] on the floating scale.
- ★ If the specific gravity is below 1.200 the battery needs to be charged.

NOTE

- The specific gravity of the electrolyte varies with changes in temperature, so the specific gravity reading must be corrected for the temperature of the electrolyte.
- Celsius: Add 0.007 points to reading for each 10° C above 20° C or subtract 0.007 points for each 10° C below 20° C.
- Fahrenheit: Add 0.004 points to reading for each 10° F above 68° F or subtract 0.004 points for each 10° F below 68° F.
- ★ If the specific gravity of any of the cells is more than 0.050 away from any other reading, the battery will probably not accept a charge. It is generally best to replace a battery in this condition.
- ★ If the specific gravity of all the cells is 1.270 or more, the battery is fully charged.

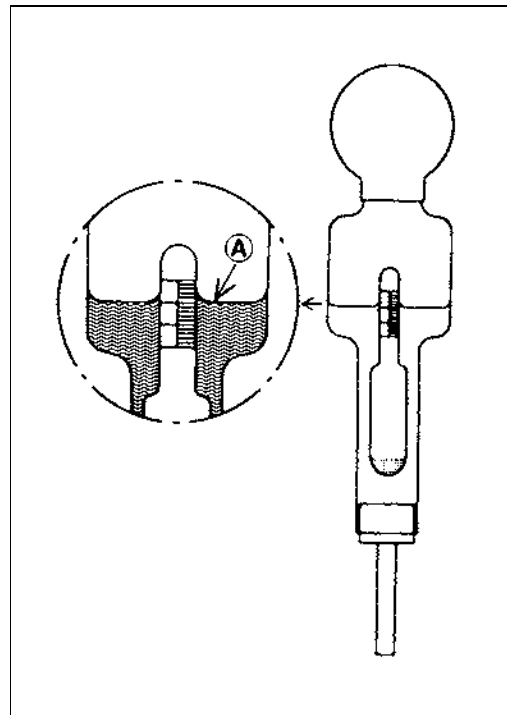

Battery

Initial Charging

⚠ WARNING

Keep the battery away from sparks and open flames during charging, since the battery gives off an explosive gas mixture of hydrogen and oxygen.

When using a battery charger, connect the battery to the charger before turning on the charger. This procedure prevents sparks at the battery terminals which could ignite any battery gases.

- Fill each cell to the upper level line on the battery case with fresh electrolyte (specific gravity: 1.270) at a temperature of 30°C (86°F) or less. Let the battery stand for about 30 minutes before charging.

NOTE

- *If the electrolyte level drops, add electrolyte to the upper level line before charging.*
- Set the charging rate at 1/10 the battery capacity, and **charge it for 10 hours**. For example, if the battery is rated at 14 Ah, the charging rate would be 1.4 Ah.

CAUTION

If the battery is not given a full initial charging, it will discharge in a few weeks. After that it can not be charged by supplemental charging.

Always remove the battery from the vehicle for charging. If the battery is charged while still installed, battery electrolyte may spill and corrode the frame or other parts of the vehicle.

Do not use a high rate battery charger, as is typically employed at automotive service stations, unless the charger rate can be reduced to the level required. Charging the battery at a rate higher than specified may ruin the battery. Charging at a high rate causes excess heat which can warp the plates and cause internal shorting. Higher-than-normal charging rates also cause the plates to shed active material. Deposits will accumulate, and can cause internal shorting.

If the temperature of the electrolyte rises above 45° C (113°F) during charging, reduce the charging rate to lower the temperature, and increase charging time proportionately.

- Turn the charger off, then disconnect it from the battery.
- Check battery voltage. Battery voltage should be 12 ~ 13 V.

16-16 ELECTRICAL SYSTEM

Battery

Ordinary Charging

- Remove the battery (see Battery Removal).

⚠ WARNING

Keep the battery away from sparks and open flames during charging, since the battery gives off an explosive gas mixture of hydrogen and oxygen. When using a battery charger, connect the battery to the charger before turning on the charger. This procedure prevents sparks at the battery terminals which could ignite any battery gases.

- Connect a charger to the battery BEFORE plugging it in or turning it on.
- Set the charging rate and time according to the battery condition previously determined, using the Battery Charging Rate/Time Table.
- Check the electrolyte level after charging.

CAUTION

Always remove the battery from the vehicle for charging. If the battery is charged while still installed, battery electrolyte may spill and corrode the frame or other parts of the vehicle. Do not use a high rate battery charger, as is typically employed at automotive service stations, unless the charger rate can be reduced to the level required. Charging the battery at a rate higher than specified may ruin the battery. Charging at a high rate causes excess heat which can warp the plates and cause internal shorting. Higher-than-normal charging rates also cause the plates to shed active material. Deposits will accumulate, and can cause internal shorting. If the temperature of the electrolyte rises above 45°C (113°F) during charging, reduce the charging rate to lower the temperature, and increase charging time proportionately.

- Turn the charger off or unplug it, then disconnect it from the battery.
- Check battery condition.
- ★ If the battery condition indicates that it is not fully charged, additional charging time is necessary.

16-18 ELECTRICAL SYSTEM

Charging System

Alternator Cover Removal

- Disconnect:
 - Alternator Lead Connector [A]
 - Pickup COil Lead Connector [B]
- Remove:
 - Recoil Starter (see Recoil Starter chapter)
 - Torque Converter Cover (see Converter System chapter)

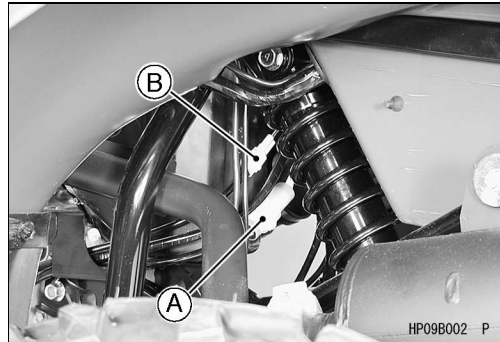

- Remove the three bolts of the drive pulley cover.
- Install and tighten the drive pulley holder [A] and the three bolt [B] as shown.

Special Tool - Drive Pulley Holder: 57001-1520

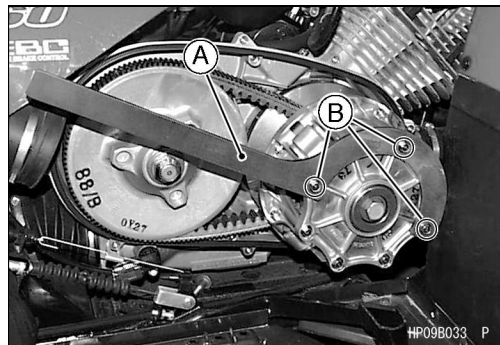

- Holding the drive pulley with the drive pulley holder, loosen the alternator rotor bolt [A].
- Remove the alternator rotor bolt and pulley.

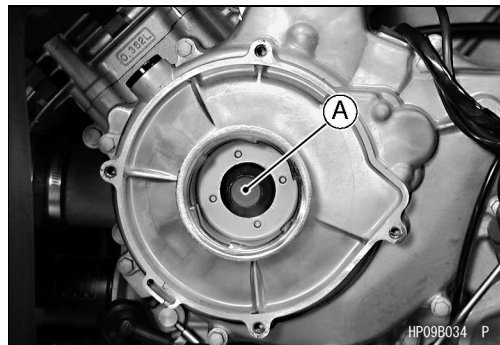

- Place an oil pan under the engine left side.
- Remove:
 - Collar [A]
 - Alternator Cover Bolts [B]
 - Alternator Cover [C]

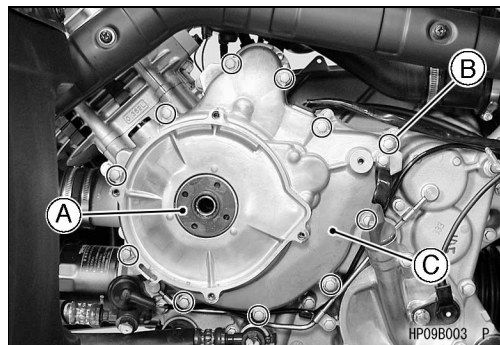

Alternator Cover Installation

- Be sure all of the old gasket has been removed from the alternator cover and the left crankcase sealing surfaces.
- Check that the dowel pins [A] are in place, and fit a new gasket on the crankcase.
- Check that the bearing [B] is in place.

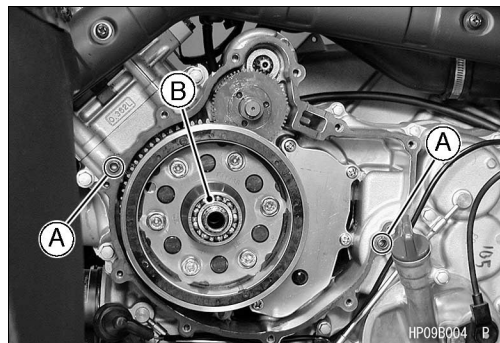

Charging System

- Fit the grommets [A] into the notch in the cover.
- Apply grease the alternator cover oil seal.
- Tighten:
Torque - Alternator Cover Bolts: 8.8 N·m (0.9 kgf·m, 78 in·lb)

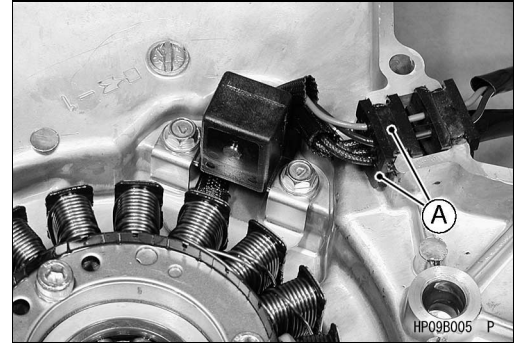

- Check that the O-ring [A] in the collar [B] is in good condition.
- Apply grease to the O-ring.
- Install the collar on the alternator cover.

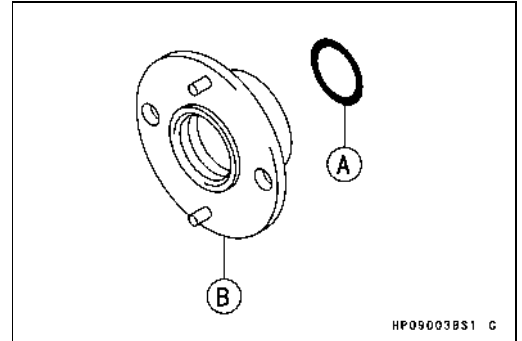

- Hold the drive pulley with the drive pulley holder [A].
Special Tool - Drive Pulley Holder: 57001-1520

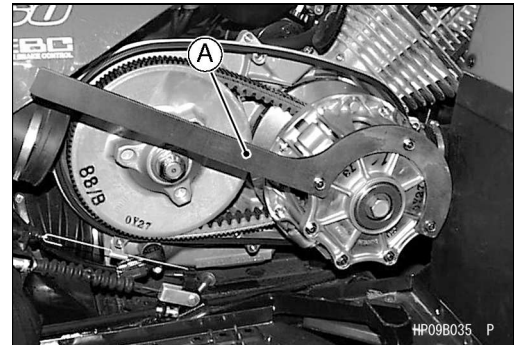

- Install the pulley [A] so that the holes of the pulley fit on the pins [B] of the collar.
- Tighten:
Torque - Alternator Rotor Bolt [C]: 127 N·m (13 kgf·m, 94 ft·lb)
- Add engine oil.

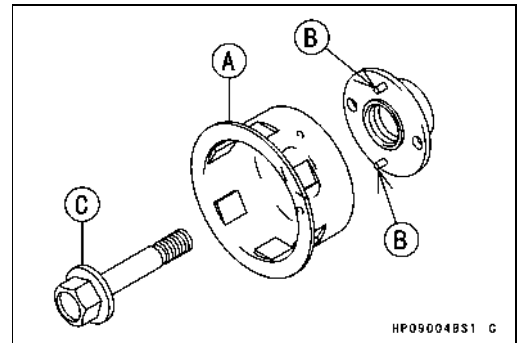

Alternator Rotor Removal

- Remove:
 Alternator Cover (see Alternator Cover Removal)
 Ball Bearing [A]

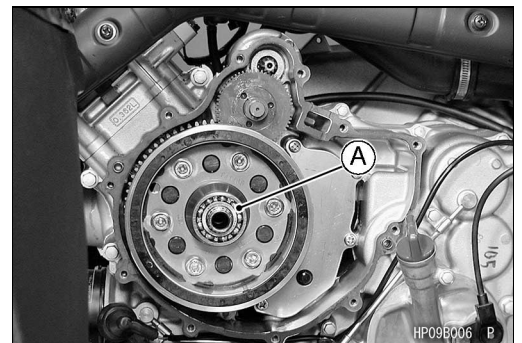

16-20 ELECTRICAL SYSTEM

Charging System

- Thread the flywheel puller [A] onto the alternator rotor.
Special Tool - Flywheel Puller: 57001-1405
- Holding the flywheel puller, turn the rotor puller until the alternator rotor is forced off the end of the crankshaft.

CAUTION

If the rotor is difficult to remove, turn the puller while tapping the end of the puller. Do not strike the alternator rotor. Striking the rotor can cause the magnets to lose magnetism.

Alternator Rotor Installation

- Apply a thin coat of molybdenum disulfide grease to the crankshaft [A].
- Install the starter clutch gear [B].

- Clean [A] the inside of the rotor and the end of the crankshaft.
- Fit the rotor onto the crankshaft so that woodruff key [B] fits in the groove [C] in the hub of the rotor.

- Install the alternator rotor [A] while turning the starter clutch gear [B].
- Install the torque limiter [C].

Alternator Stator Removal

- Remove:
Alternator Cover (see Alternator Cover Removal)
Pickup Coil [A] (see Pickup Coil Removal)
Bolts [B] and Alternator Stator [C]

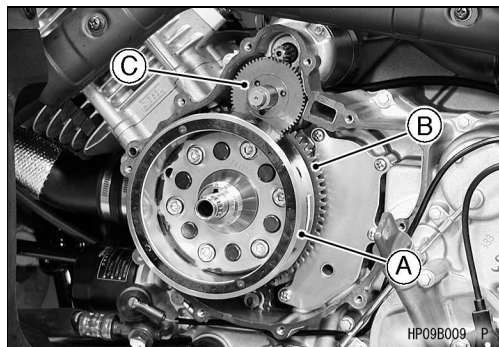
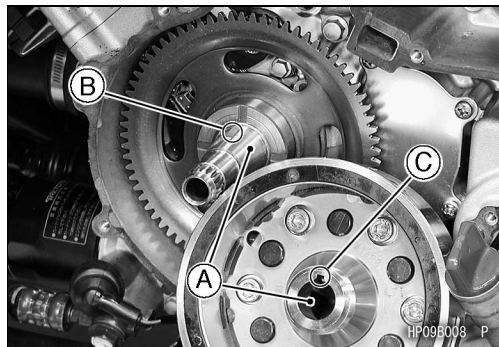
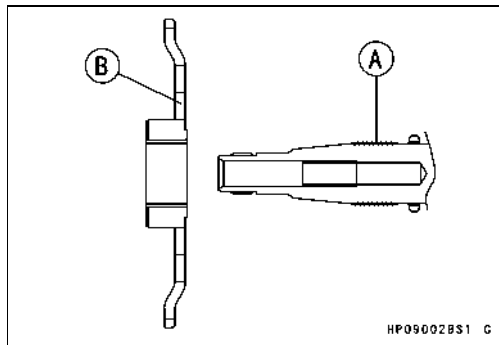
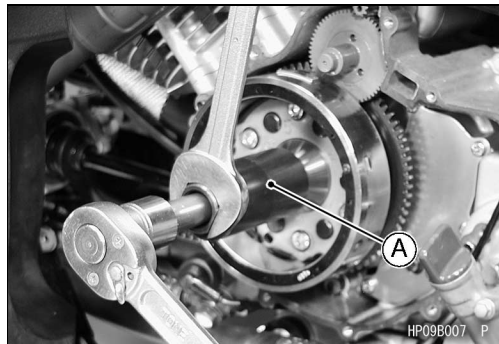

Charging System

Alternator Stator Installation

- Tighten:
 - Torque - Alternator Stator Bolts: 14 N·m (1.4 kgf·m, 10 in·lb)**
- Install:
 - Pickup Coil (see Pickup Coil Installation)
- Fit the lead grommets into the notch on the alternator cover.
 - Grommets [A] for Alternator Leads
 - Grommets [B] for Pickup Coil Leads

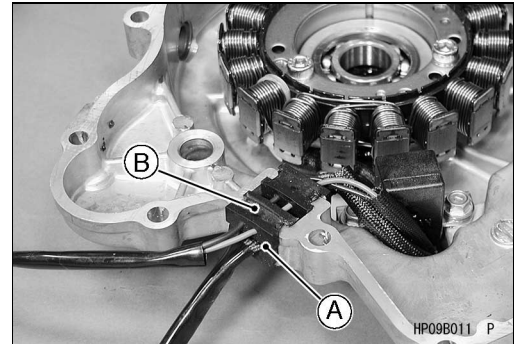

Regulator/Rectifier Output Voltage Inspection

- Remove the seat (see Frame chapter).
- Check the battery condition (see Battery section).
- Warm up the engine to obtain actual alternator operating conditions.
- Check that the ignition switch is turned off, and connect a hand tester [A] to the battery terminals.

Special Tool - Hand Tester : 57001-1394

- Start the engine and note the voltage readings at various engine speeds with the headlight turned on and then off. The readings should show nearly battery voltage when the engine speed is low, and as the engine speed increases, the readings should also increase.



Regulator/Rectifier Output Voltage

Tester Range	Connections		Reading
	Tester (+) to	Tester (-) to	
25 V DC	Battery (+)	Battery (-)	14 ~ 15 V

- Turn off the ignition switch, and disconnect the hand tester.
- ★ If the regulator/rectifier output voltage is between the values given in the table, the charging system is working normally.
- ★ If the output voltage is much higher than the values specified in the table, the regulator/rectifier is defective or the regulator/rectifier leads are loose or open.
- ★ If the battery voltage does not increase as the engine speed increases, then the regulator/rectifier is defective or the alternator output is insufficient for the loads. Check the alternator and regulator/rectifier to determine which part is defective.

Alternator Inspection

There are three types of alternator failures: short, open, or loss in rotor magnetism. A short or open in one of the coil wires will result in either a low output, or no output at all. A loss in rotor magnetism, which may be caused by dropping or hitting the alternator, by leaving it near an electromagnetic field, or just by aging, will result in low output.

- To check the alternator output voltage, perform the following procedures.
 - Disconnect the alternator connector [A].
 - Connect a hand tester as shown in the table.
 - Start the engine.
 - Run it at the rpm given in the table.
 - Note the voltage readings (total 3 measurements).



Alternator Output Voltage

Tester Range	Connections		Reading
	Tester (+) to	Tester (-) to	
250 V AC	One black lead	Another black lead	@3 000rpm 36 ~ 54 V

- ★ If the output voltage is within the values in the table, the alternator is operating correctly, and the regulator/rectifier is damaged. A much lower reading indicates that the alternator is defective.

16-22 ELECTRICAL SYSTEM

Charging System

- Check the stator coil resistance as follows:
 - Stop the engine.
 - Disconnect the alternator connector.
 - Connect a hand tester as shown in the table.
 - Note the readings (total 3 measurement).

Stator Coil Resistance

Tester Range	Connections		Reading
	Tester (+) to	Tester (-) to	
x 1 Ω	One black lead	Another black lead	0.33 ~ 0.49 Ω

- ★ If there is more resistance than shown in the table, or no reading (infinity) for any two leads, the stator has an open and must be replaced. Much less resistance means the stator is shorted and must be replaced.
- Using the highest resistance range of the hand tester, measure the resistance between each of the black leads and chassis ground.
- ★ Any reading less than infinity (∞) indicates a short, necessitating stator replacement.
- ★ If the stator coils have normal resistance, but the voltage check shows the alternator to be defective; then the rotor magnetism has probably weakened, and the rotor must be replaced.

Special Tool - Hand Tester : 57001-1394

Regulator/Rectifier Inspection

- Remove:
 - Bolts [A] and Regulator/Rectifier [B]
 - Connectors [C] (disconnect)

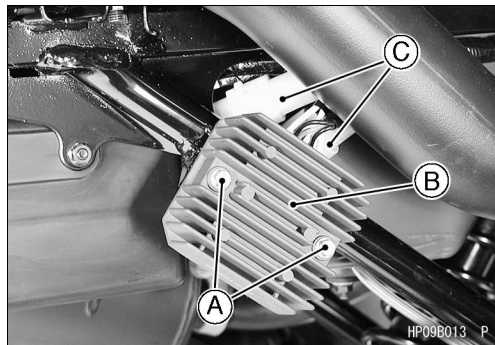

Rectifier Circuit Check:

- Check conductivity of the following pair of terminals.

Rectifier Circuit Inspection

Tester connection	W/R-Y1,	W/R-Y2,	W/R-Y3
	BK-Y1,	BK-Y2,	BK-Y3

- ★ The resistance should be low in one direction and more than ten times as much in the other direction. If any two leads are low or high in both directions, the rectifier is defective and must be replaced.

NOTE

- The actual meter reading varies with the meter and the individual rectifier. Generally speaking the lower reading should be from zero to one half of the scale.

Regulator Circuit Check:

To test the regulator out of circuit, use three 12 V batteries and a test light (12 V 3 ~ 6 W bulb in a socket with leads).

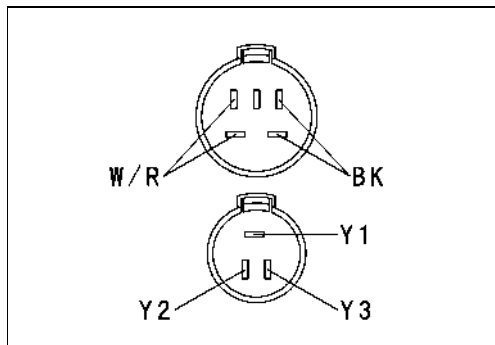

CAUTION

The test light works as an indicator and also a current limiter to protect the regulator/rectifier from excessive current. Do not use an ammeter instead of a test light.

- Check to be sure the rectifier circuit is correct before continuing.

Charging System

Regulator Circuit Test-1st Step:

- Connect the test light and the 12 V battery to the regulator/rectifier as shown.
- Check Y1, Y2, and Y3 terminal respectively.
- ★ If the test light turns on, the regulator/rectifier is defective.
- ★ If the test light does not turn on, continue the test.

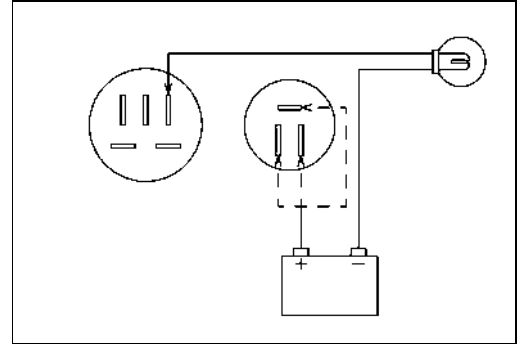

Regulator Circuit Test-2nd Step:

- Connect the test light and a 12 V battery in the same manner as specified in the "Regulator Circuit Test-1st Step".
- Apply 12 V to the BR terminal.
- Check Y1, Y2, and Y3 terminals.
- ★ If the test light turns on, the regulator/rectifier is defective.
- ★ If the test light does not turn on, continue the test.

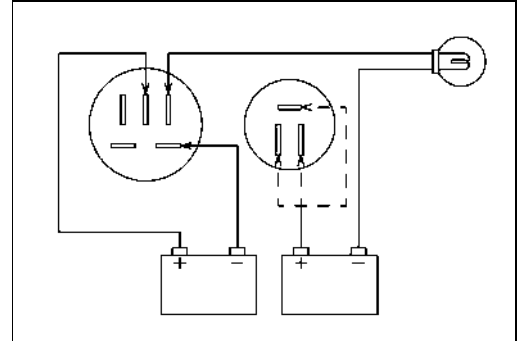

Regulator Circuit Test-3rd Step:

- Connect the test light and a 12 V battery in the same manner as specified in the "Regulator Circuit Test-1st Step".
- Momentarily apply 24 V to the BR terminal by adding a 12 V battery.
- Check Y1, Y2, and Y3 terminals.

CAUTION

Do not apply more than 24 V to the regulator/rectifier. Do not leave the 24 V applied for more than a few seconds, or the unit will be damaged.

- ★ If the test light did not light when the 24 V was applied momentarily to the BR terminal, the regulator/rectifier is defective.
- ★ If the regulator/rectifier passes all of the tests described, it may still be defective. If the charging system still does not work properly after checking all of the components and the battery, test the regulator/rectifier by replacing it with a known good unit.

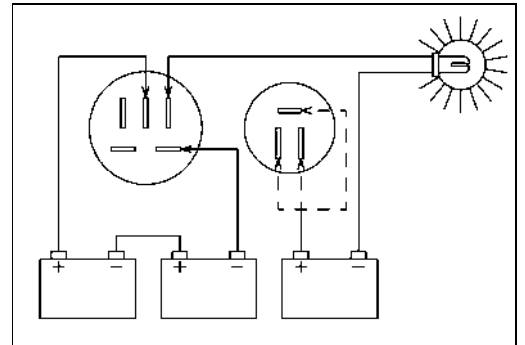

16-24 ELECTRICAL SYSTEM

Charging System

Charging System Circuit

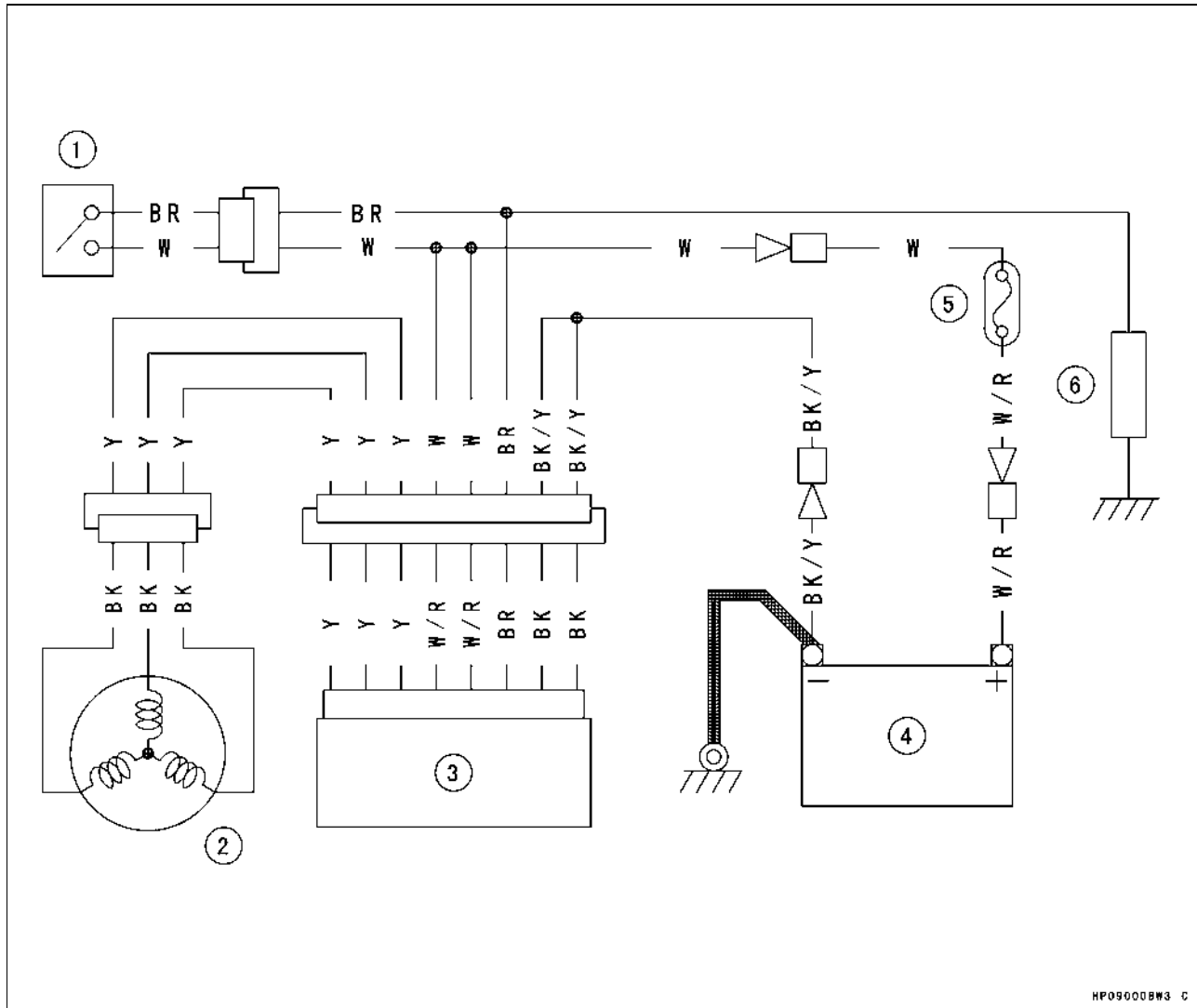

1. Ignition Switch
2. Alternator

3. Regulator/Rectifier
4. Battery

5. Main Fuse 30 A
6. Load

Ignition System

⚠ WARNING

The ignition system produces extremely high voltage. Do not touch the spark plug, ignition coil, or spark plug lead while the engine is running, or you could receive a severe electrical shock.

CAUTION

Do not disconnect the battery leads or any other electrical connections when the ignition switch is on, or while the engine is running. This is to prevent igniter damage.

Do not install the battery backwards. The negative side is grounded. This is to prevent damage to the diodes and igniter. Use the standard regulator/rectifier, or the igniter will be damaged.

Spark Plug Removal

- Remove:
 - Spark Plug Cap [A]
 - Spark Plug [B]

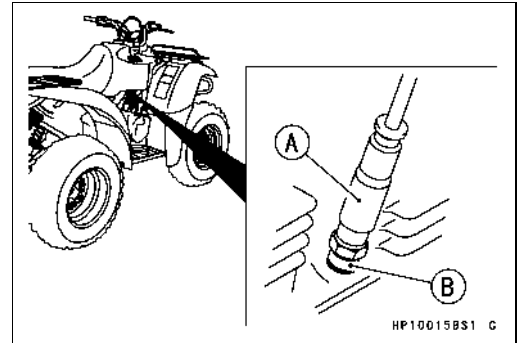

Spark Plug Installation

- Tighten:
 - Torque - Spark Plugs: 14 N·m (1.4 kgf·m, 10 ft·lb)**
- Fit the spark plug cap securely.
- Pull up the spark plug cap lightly to make sure of the installation of the spark plug cap.

Spark Plug Cleaning / Inspection

- Clean the spark plug, preferably in a sandblasting device, and then clean off any abrasive particles. The plug may also be cleaned using a wire brush or other suitable tool.
- ★ If the spark plug electrodes are corroded or damaged, or if the insulator is cracked, replace the plug. Use the standard spark plug or its equivalent.

Spark Plug Gap Inspection

- Refer to Spark Plug Gap Inspection in Periodic Maintenance chapter.

16-26 ELECTRICAL SYSTEM

Ignition System

Ignition Coil Removal

- Remove:
 - Front Right Inner Cover (see Frame chapter)
 - Spark Plug Cap [A]
 - Primary Lead Connectors [B]
 - Ignition Coil Mounting Bolt [C]
 - Ignition Coil [D]

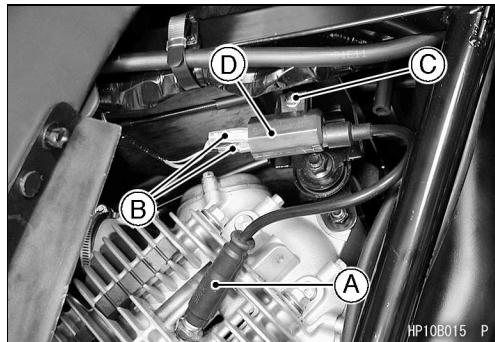

Ignition Coil Installation

- Connect the primary leads to the ignition coil terminals as shown.
 - G/W Lead → (+) Mark [A]
 - BK/Y Lead → (-) Mark
- Tighten:
 - Torque - Ignition Coil Mounting Bolt: 8.8 N·m (0.9 kgf·m, 78 in·lb)

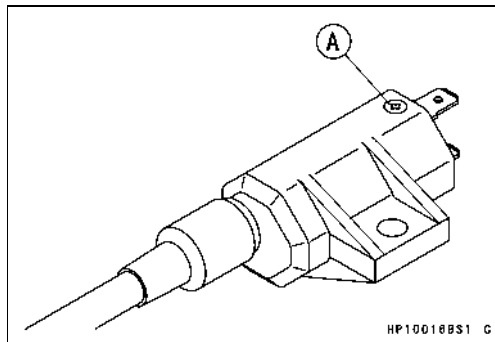

Ignition Coil Inspection

- Remove the ignition coil.
- Measure the arcing distance with a coil tester [A] to check the condition of the ignition coil [B].
- Connect the ignition coil (with the spark plug cap left attached at the end of the spark plug lead) to the tester in the manner prescribed by the manufacturer and measure the arcing distance.

Ignition Coil Arcing Distance
7 mm (0.28 in.) or more

⚠ WARNING

To avoid extremely high voltage shocks, do not touch the ignition coil body or leads.

- ★ If the distance reading is less than the specified value, the ignition coil or spark plug cap is defective.
- To determine which part is defective, measure the arcing distance again with the spark plug cap removed from the ignition coil. Remove the cap by turning it counterclockwise.
- ★ If the arcing distance is as before, the trouble is with the ignition coil. If the arcing distance is normal, the trouble is with the spark plug cap.
- ★ If a coil tester is not available, the coil can be checked for a broken or badly shorted winding with a hand tester.

Special Tool - Hand Tester : 57001-1394

NOTE

- The hand tester cannot detect layer shorts and shorts resulting from insulation breakdown under high voltage.

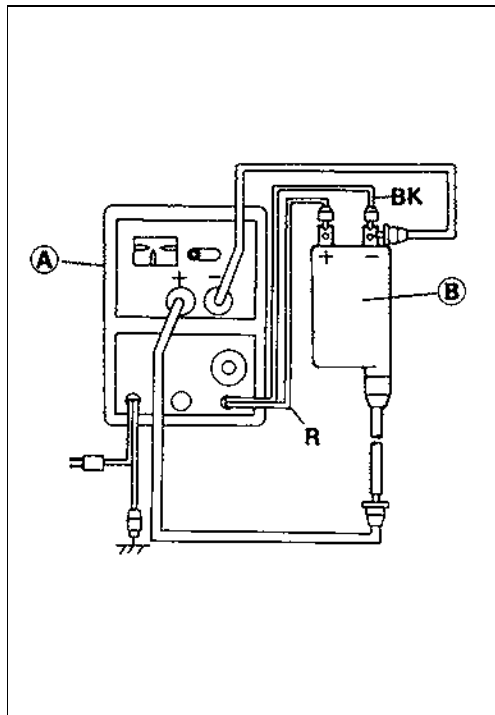

Ignition System

- Measure the primary winding resistance [A] as follows:
 - Connect the tester between the coil terminals.
 - Set the tester to the x 1 Ω range.
- Measure the secondary winding resistance [B] as follows:
 - Remove the plug cap by turning it counterclockwise.
 - Connect the tester between the spark plug lead and terminal.
 - Set the tester to the x 1 kΩ range.

Ignition Coil Winding Resistance

Primary windings : 0.09 ~ 0.13 Ω

Secondary windings : 3.8 ~ 5.8 kΩ

- ★ If the hand tester does not read as specified, replace the coil.
- To install the plug cap, turn it clockwise.

Ignition Coil Primary Peak Voltage Inspection

NOTE

- Be sure the battery is fully charged.
- Remove the spark plug cap (see Spark Plug Removal), but do not remove the spark plug.
- Measure the primary peak voltage as follows.
 - Connect a commercial peak voltage adapter [A] to the hand tester [B] (250 V DC range).

Special Tool - Hand Tester: 57001-1394

Recommended Tool - Peak Voltage Adapter
 Type: KEK-54-9-B
 Brand: KOWA SEIKI

- Connect the adapter between the G/W lead terminal of the ignition coil [C] and the engine ground [D].
- Install a new spark plug [E] into the spark plug cap, and ground it to the engine.

⚠ WARNING

To avoid extremely high voltage shocks, do not touch the spark plugs or tester connections.

- Turn the ignition switch ON, rotate the engine for 4 ~ 5 seconds with the transmission in neutral to measure the primary peak voltage.
- Repeat the measurements 5 times for one ignition coil.

Ignition Coil Primary Peak Voltage

Standard: 100 V or more

- ★ If the reading is less than the specified value, check the following.
 - Ignition Coils (see Ignition Coil Inspection)
 - Pickup Coil (see Pickup Coil Inspection)
- ★ If the ignition coils and pickup coil are normal, see the Ignition System Troubleshooting chart on page 16-30.

Pickup Coil Removal

- Remove:
 - Alternator Cover (see Alternator Cover Removal)
 - Pickup Coil Mounting Bolts [A]
 - Plate [B]
 - Pickup Coil [C]

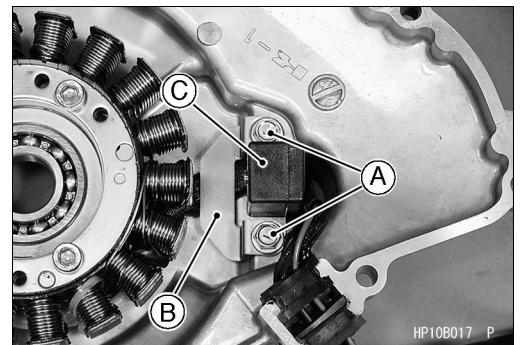
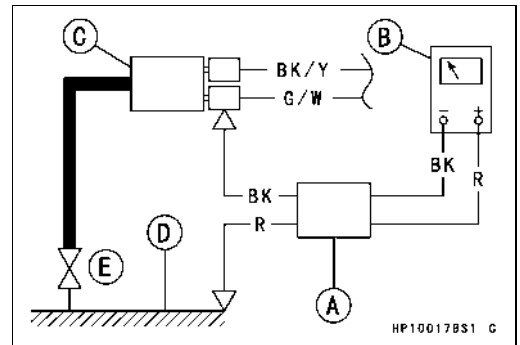
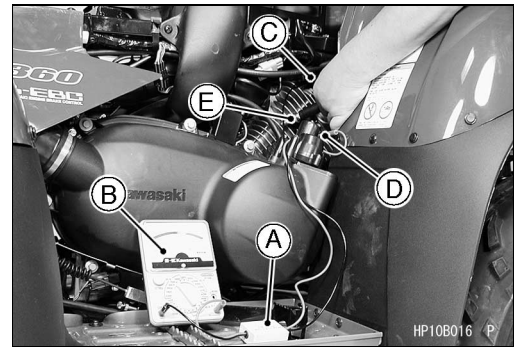
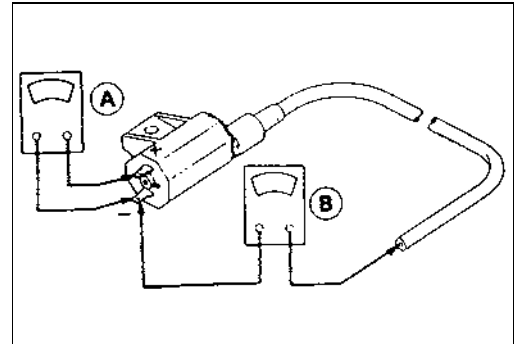

16-28 ELECTRICAL SYSTEM

Ignition System

Pickup Coil Installation

- Install:
 - Stator Coil Leads [A]
 - Plate [B]
 - Pickup Coil [C]
- Tighten:
 - Torque - Pickup Coil Mounting Bolts: 5.9 N·m (0.6 kgf·m, 52 in·lb)

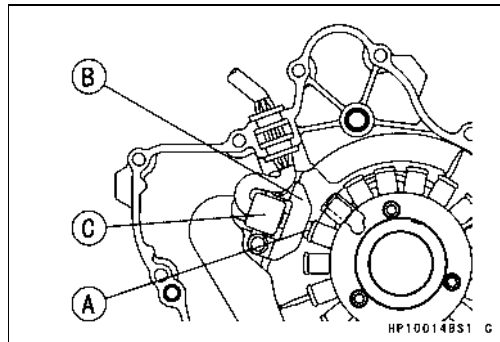

- Fit the lead grommets into the notch on the alternator cover.
 - Grommets [A] for Alternator Leads
 - Grommets [B] for Pickup Coil Leads

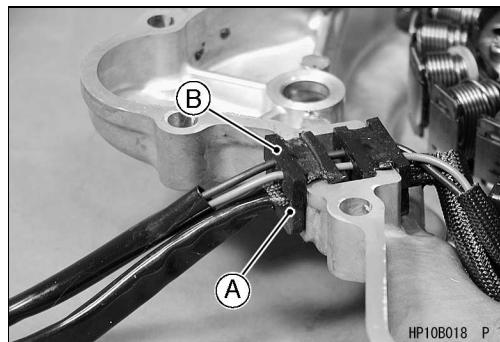

Pickup Coil Inspection

- Remove the seat (see Frame chapter).
- Disconnect the pickup coil lead connector [A].
- Measure the pickup coil resistance.
 - Connect a hand tester between the BK/W lead and the BL lead.
 - Set the tester to the x 10 Ω range.

Pickup Coil Resistance
110 ~ 140 Ω

- ★ If the tester does not read as specified, replace the pickup coil.

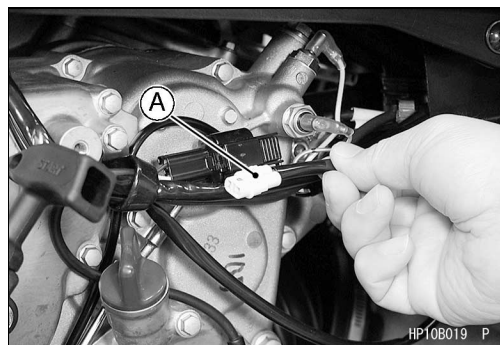

Pickup Coil Peak Voltage Inspection

NOTE

- Be sure the battery is fully charged.
- Remove the spark plug caps, but do not remove the spark plugs.
- Disconnect:
 - Pickup Coil Wire Connector [A]
- Set the hand tester [B] to the 10 V DC range.
- Connect the peak voltage adapter [C] to the hand tester and pickup coil leads in the connector.

Special Tool - Hand Tester: 57001-1394

Recommended Tool - Peak Voltage Adapter
Type: KEK-54-9-B
Brand: KOWA SEIKI

Connections:

Pickup Coil Connector		Adapter		Hand Tester
Bule	←	Red	→	(+)
Black/White	←	Black	→	(-)

- Turn the ignition switch on, and rotate the engine for 4 ~ 5 seconds with the transmission gear in neutral to measure the pickup coil peak voltage.

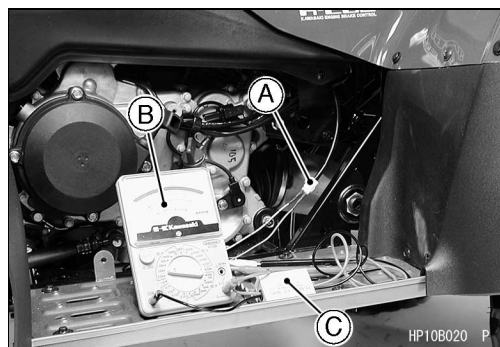

Ignition System

- Repeat the measurement 5 or more times.

Pickup Coil Peak Voltage

Standard: 3.6 V or more

- ★ If the peak voltage is lower than the standard, inspect the pickup coil.

Alternator Rotor Inspection

- Check the timing projection [A] for damage such as chipping or grooving.
- ★ If the timing projection on the rotor is visibly damaged, replace the alternator rotor.

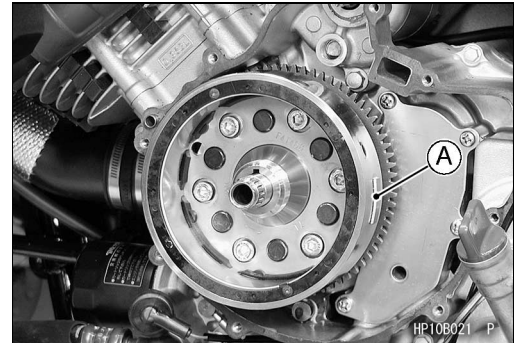

Ignition Timing Test

- Remove the ignition timing inspection plug.
- Attach a timing light [A] and a tachometer in the manner prescribed by the manufacturer.

Special Tool - Timing Light : 57001-1241

- Start the engine and aim the timing light at the timing mark on the alternator rotor.
- Run the engine at the speeds specified and note the alignment of the timing marks.

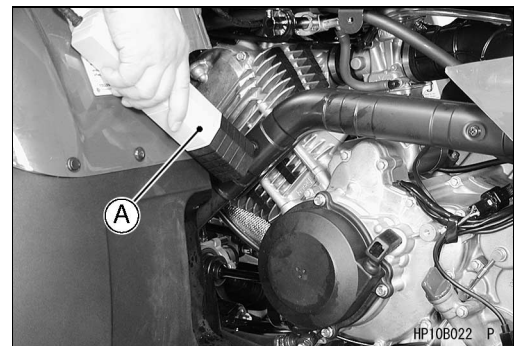

Ignition Timing

Engine speed r/min (rpm)	Slot [A] aligned with:
1 000	Advanced mark [B] on alternator rotor
5 000	Advanced mark [C] on alternator rotor

NOTE

- Do not mix up the timing marks with mark.
- ★ If the ignition timing is incorrect, replace the igniter and the pickup coil.

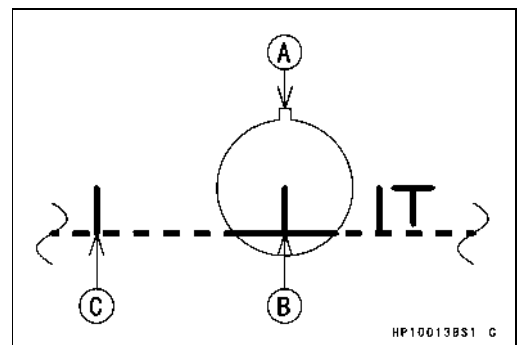

16-30 ELECTRICAL SYSTEM

Ignition System

Ignition System Troubleshooting

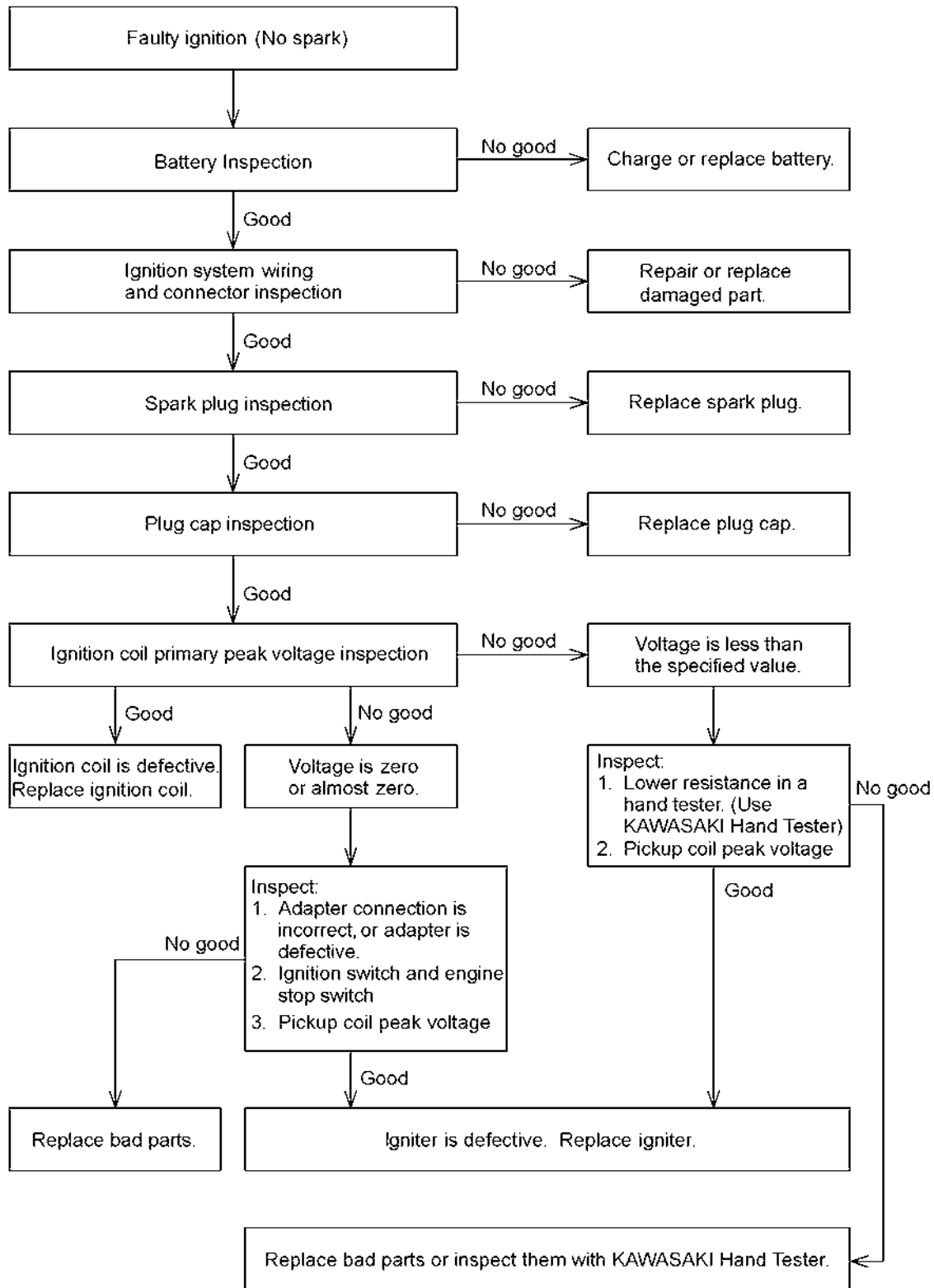

Ignition System

Ignition System Circuit

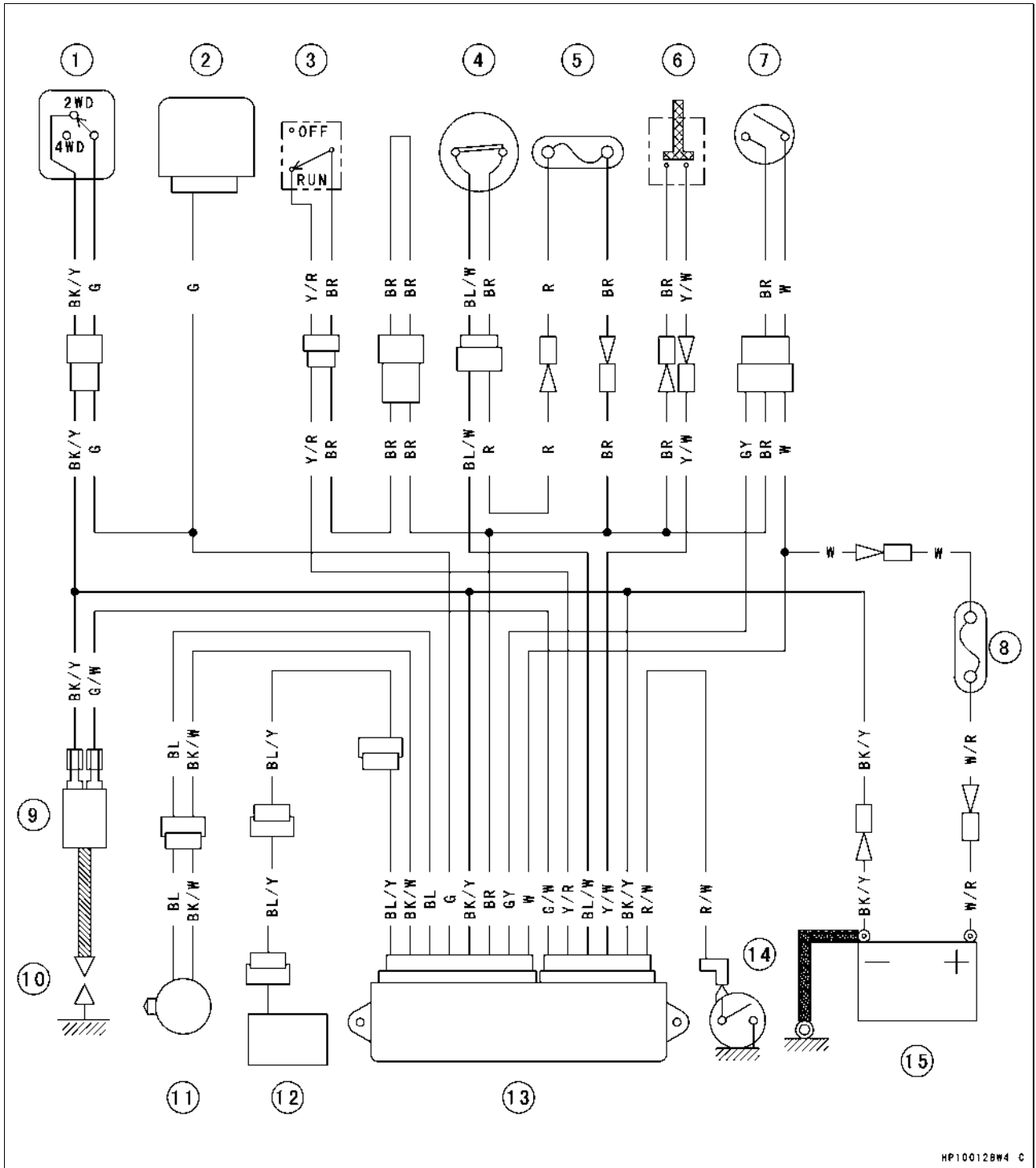

HP100128W4 C

- | | |
|---|-----------------------------|
| 1. 2WD/4WD Shift Switch | 8. Main Fuse 30A |
| 2. Actuator Controller | 9. Ignition Coil |
| 3. Engine Stop Switch | 10. Spark Plug |
| 4. Drive Belt Failure Detecting Switch | 11. Pickup Coil |
| 5. Drive Belt Failure Detecting Switch Fuse
5A | 12. LED Indicator |
| 6. Reverse Power Assist Switch (Override) | 13. Igniter |
| 7. Ignition Switch | 14. Reverse Position Switch |
| | 15. Battery |

16-32 ELECTRICAL SYSTEM

Electric Starter System

Starter Motor Removal

- Remove:
 - Fuel Tank Cover (see Fuel System chapter)
 - Starter Motor Cable [A]
 - Starter Motor Mounting Bolts [B]
 - Starter Motor [C]

CAUTION

Do not tap the end of the starter motor shaft or the motor may be damaged.

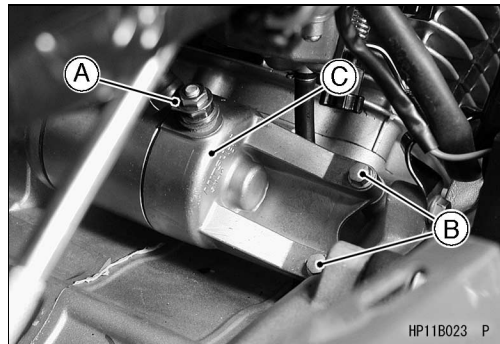

Starter Motor Installation

- When installing the starter motor, clean the starter motor lugs [A] and crankcase [B] where the starter motor is grounded.

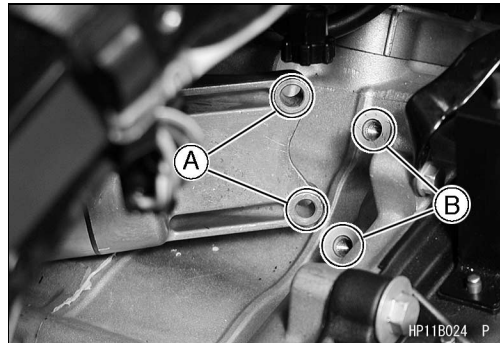

- ★ If the O-ring [A] shows wear or damage, or if it is hardened, replace it with a new one.

- Apply a small amount of engine oil to the O-ring.

- Install:
 - Starter Motor
 - Starter Motor Cable

- Tighten:

Torque - Starter Motor Mounting Bolts: 8.8 N·m (0.9 kgf·m, 78 in·lb)
Starter Motor Terminal Nut: 4.9 N·m (0.5 kgf·m, 43 in·lb)

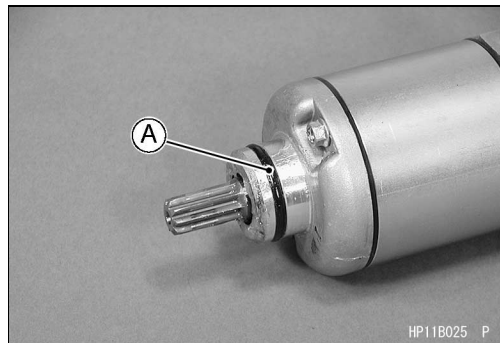

Starter Motor Disassembly

- Remove:
 - Starter Motor Bolts [A]
 - Left End Cover [B]
 - Right End Cover [C]
 - Yoke [D]

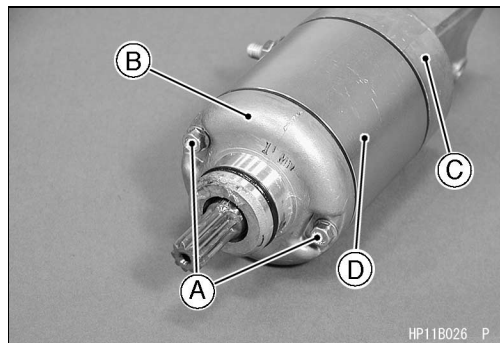

- To remove the brush plate assembly [A], remove the terminal nut [B].

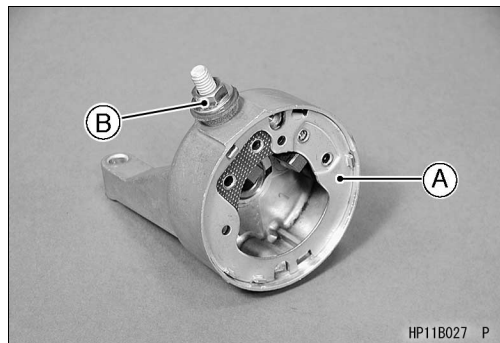

Electric Starter System

- Hold the brush spring [A] with needle nose pliers, and pull the brush [B] off the holder.

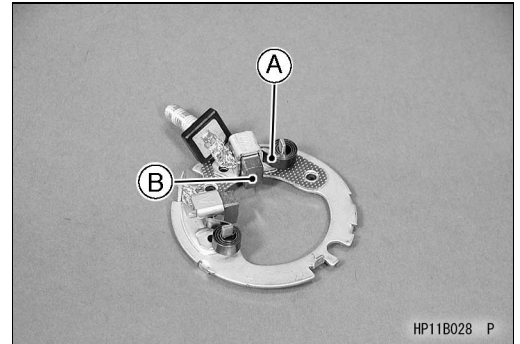

Starter Motor Assembly

- Replace the O-rings.
- Install the brush plate assembly to the right end cover so that the projection [A] on the brush plate fits into the groove on the right end cover.
- Install the O-ring, insulators [B], and washer [C] in that order on the terminal bolt.
- Tighten:
 - Torque - Starter Motor Terminal Locknut [D]: 6.9 N·m (0.7 kgf·m, 61 in·lb)**

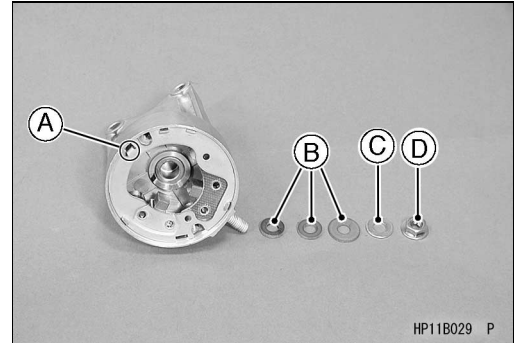

- Install the washers [A].
- Install the armature [B] between the brushes.

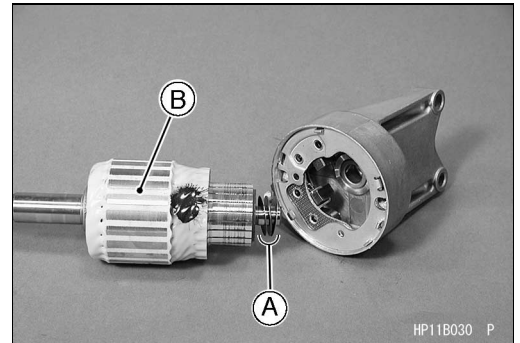

- Install the yoke [A] onto the right end cover [B] aligning the marks [C] on the yoke and right end cover.

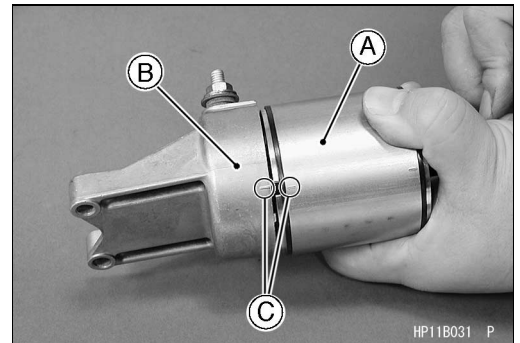

- Install the washers [A].

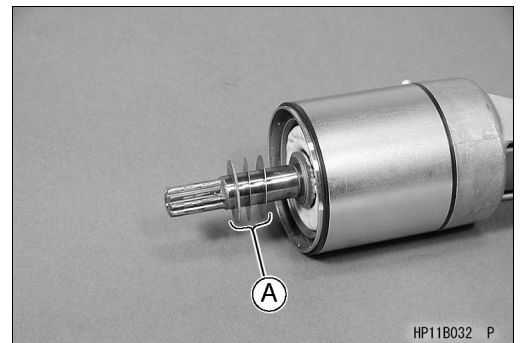

16-34 ELECTRICAL SYSTEM

Electric Starter System

- Install the plate [A] on the left end cover [B].

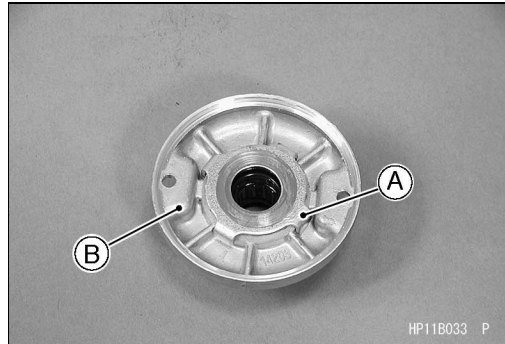

- Align the mark [A] on the left end cover with the mark [B] on the yoke.

- Tighten:

Torque - Starter Motor Bolts: 3.4 N·m (0.3 kgf·m, 30 in·lb)

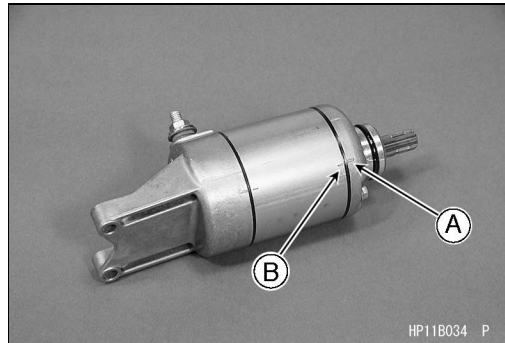

Commutator Cleaning/Inspection

- Smooth the commutator surface [A] if necessary with fine emery cloth [B], and clean out the grooves.

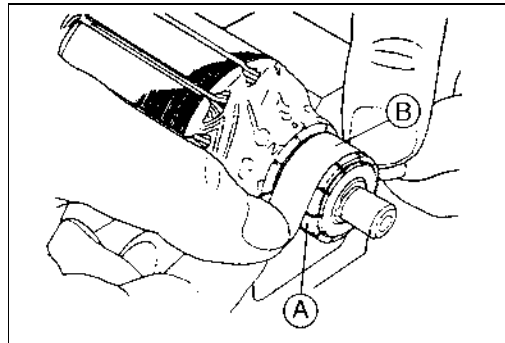

- Measure the diameter [A] of the commutator.

- ★ Replace the starter motor with a new one if the commutator diameter is less than the service limit.

Commutator Diameter

Standard: 28 mm (1.10 in.)

Service Limit: 27 mm (1.06 in.)

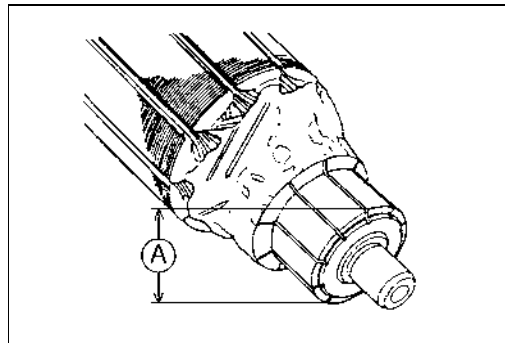

Electric Starter System

Armature Inspection

- Using the $\times 1 \Omega$ range, measure the resistance between any two commutator segments [A].
- ★ If there is a high resistance or no reading (∞) between any two segments, a winding is open. Replace the starter motor.
- Using the highest range, measure the resistance between the segments and the shaft [B].
- ★ If there is any reading at all, the armature has a short. Replace the starter motor.

NOTE

- Even if the foregoing checks show the armature to be good, it may be defective in some manner not readily detectable with the hand tester. If all other starter motor and starter motor circuit components check good, but the starter motor still does not turn over or only turns over weakly, replace the starter motor with a new one.

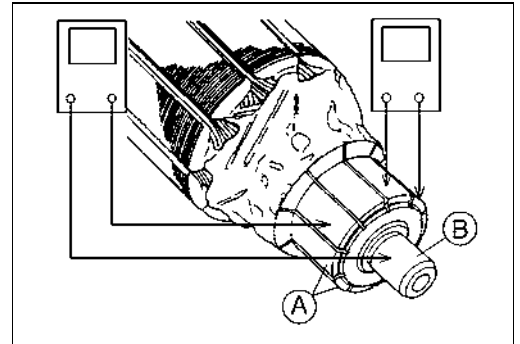

Starter Motor Brush Length

- Measure the overall length [A] of each brush.

Starter Motor Brush Length

Standard:	10 mm (0.39 in.)
Service Limit:	3.5 mm (0.14 in.)

- ★ If any is worn down to the service limit, replace the brush plate assembly.

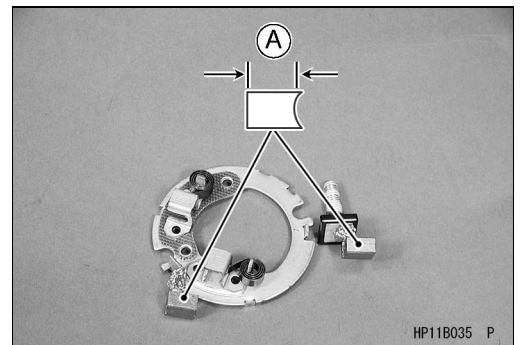

Brush Assembly Inspection

- Using the $\times 1 \Omega$ range, measure the resistance as shown.
 - [A] Terminal Bolt and Positive Brush
 - [B] Brush Plate and Negative Brush
- ★ If there is not close to zero ohms, the brush lead has an open. Replace the brush plate assembly.

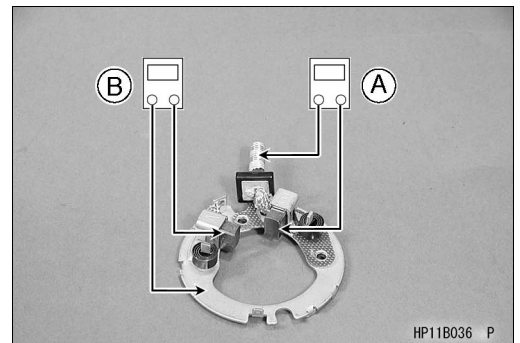

Brush Plate and Terminal Bolt Inspection

- Using the highest range, measure the resistance as follows:
 - [A] Terminal Bolt and Right – Hand End Cover
 - [B] Terminal Bolt and Brush Plate
- ★ If there is any reading, the brush holder assembly has a short. Replace the brush plate assembly.

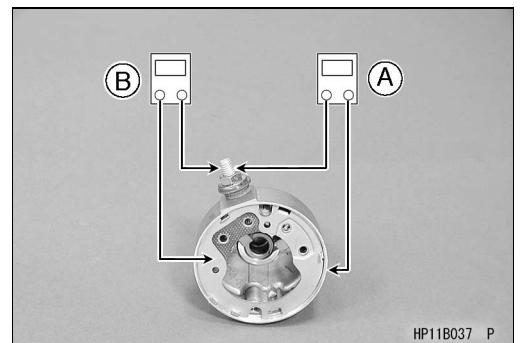

16-36 ELECTRICAL SYSTEM

Electric Starter System

Starter Relay Inspection

- Remove:
 - Seat (see Frame chapter)
 - Starter Relay [A]

- Connect the hand tester [A] and a 12 V battery [B] to the starter relay as shown.
- ★ If the relay does not work as specified, the relay is defective. Replace the relay.

Testing Relay

Hand Tester Range: x 1 Ω range

- Criteria : When battery is connected \Rightarrow 0 Ω
 When battery is disconnected \Rightarrow ∞ Ω

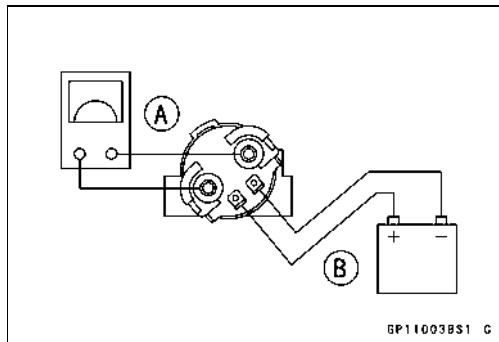
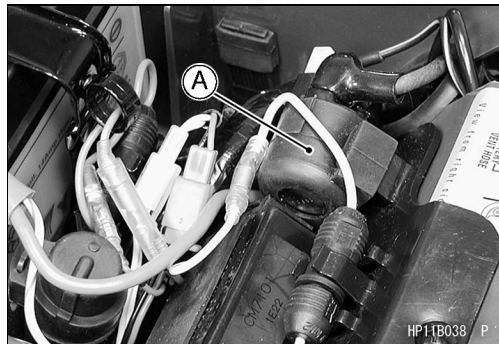

Starter Circuit Relay Inspection

- Remove:
 - Seat (see Frame chapter).
 - Starter Circuit Relay [A] (Brake Switch Circuit)
 - Starter Circuit Relay [B] (Neutral Switch Circuit)
- The starter circuit relays for the brake and neutral switch circuits are identical.

- Connect the hand tester [A] and a 12 V battery [B] to the starter circuit relay [C] as shown.
- ★ If the relay does not work as specified, the relay is defective. Replace the relay.

Testing Relay

Hand Tester Range: x 1 Ω

- Criteria: When battery is connected \Rightarrow 0 Ω
 When battery is disconnected \Rightarrow ∞ Ω

- Relay Coil Terminals [1] and [2]
Relay Switch Terminals [3] and [4]

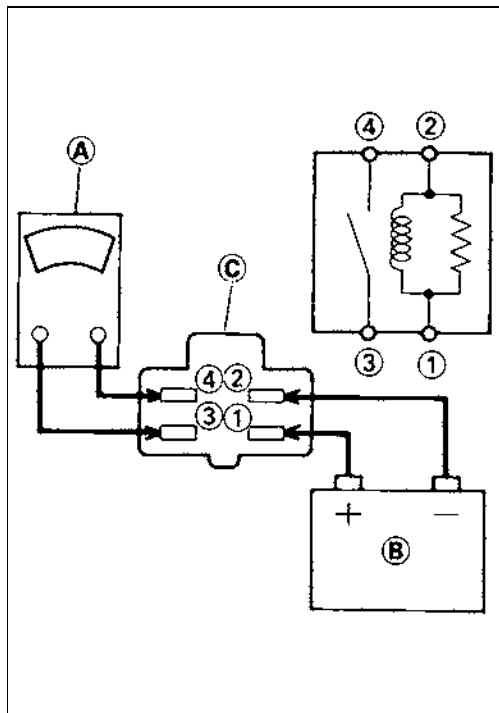
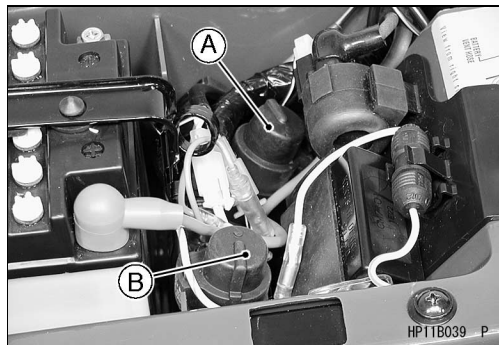

Electric Starter System

Electric Starter Circuit

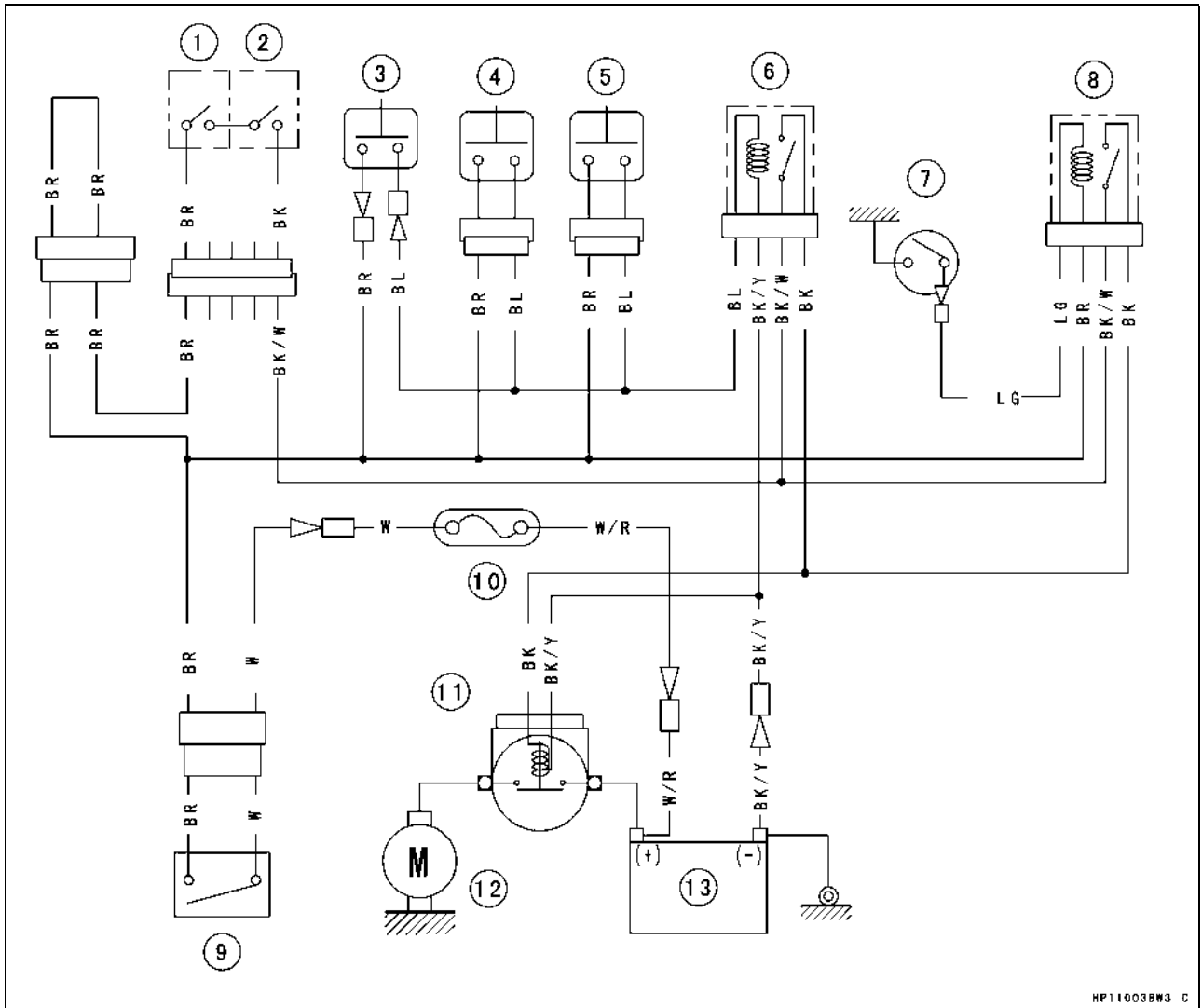

HP11003BW3 C

- | | | |
|-------------------------------|------------------------------------|-------------------|
| 1. Engine Stop Switch | 6. Starter Circuit Relay (Brake) | 10. Main Fuse 30A |
| 2. Starter Button | 7. Neutral Switch | 11. Starter Relay |
| 3. Front Brake Light Switch | 8. Starter Circuit Relay (Neutral) | 12. Starter Motor |
| 4. Parking Brake Light Switch | 9. Ignition Switch | 13. Battery |
| 5. Rear Brake Light Switch | | |

Starter Motor Clutch Removal

- Remove the alternator rotor (see Alternator Rotor Removal).
- Hold the rotor with the flywheel holder and take out the starter motor clutch bolts [A].

Special Tool - Flywheel Holder: 57001-1313

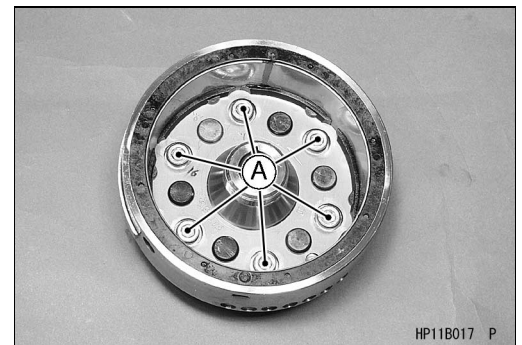

HP11B017 P

16-38 ELECTRICAL SYSTEM

Electric Starter System

- Take out the one-way clutch [A].

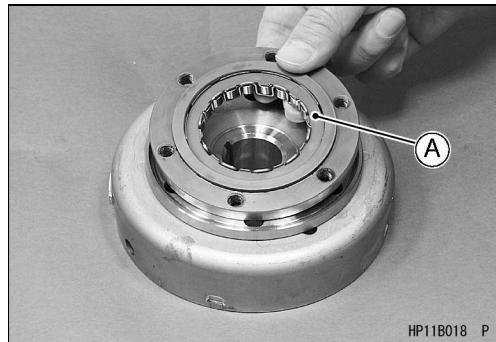

Starter Motor Clutch Installation

- Install the one-way clutch so that the flange [A] fits on the recess [B] of the race.
- Apply engine oil:
One-Way Clutch
- Apply a non-permanent locking agent:
Starter Motor Clutch Bolts
- Tighten:
Torque - Starter Motor Clutch Bolts : 34 N·m (3.5 kgf·m, 25 ft·lb)

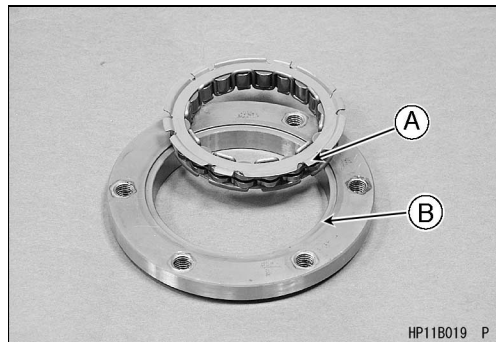

Starter Motor Clutch Inspection

- Remove:
Alternator Rotor (see Alternator Rotor Removal)
- Fit the starter clutch gear into the starter motor clutch.
- ★ If the alternator rotor turns counterclockwise [A] freely from the starter clutch gear, but not clockwise [B], the clutch is operating correctly.
- ★ If the clutch does not operate correctly, or if it makes noise, disassemble it and examine each part visually. Replace any worn or damaged parts.

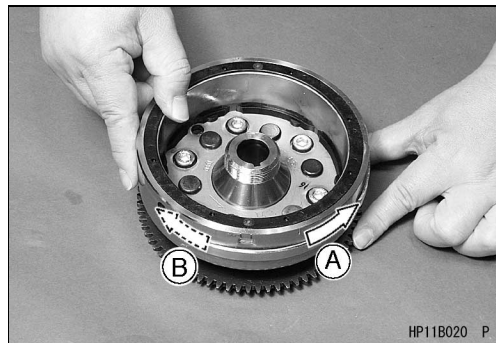

NOTE

- Examine the starter clutch gear [A]. Replace it if it is worn or damaged.

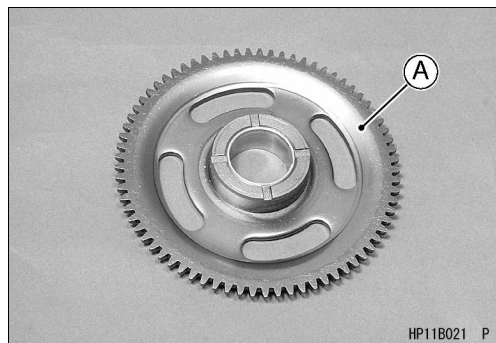

Torque Limiter Inspection

- Remove:
Alternator Rotor (see Electrical System chapter)
- Remove the torque limiter [A] and visually inspect it.
- ★ If the limiter has wear, discoloration, or other damage, replace it as a unit.

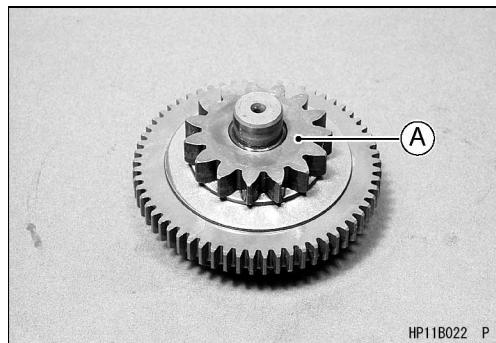

Lighting System

Headlight Beam Vertical Adjustment

- Turn the adjusting screw [A] on each headlight rim in or out to adjust the headlight vertically.

NOTE

- On high beam, the brightest point should be slightly below horizontal with the vehicle on its wheels and the rider seated. Adjust both headlights to the same angle.

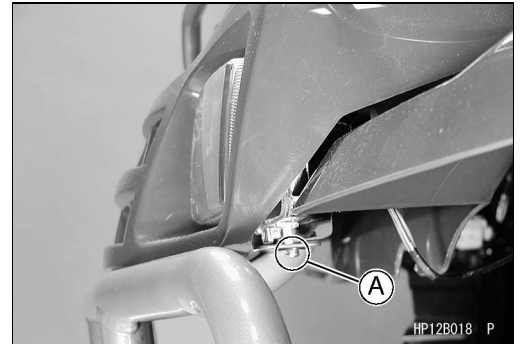

Headlight Bulb Replacement

- Disconnect:
Headlight Lead Connector [A]
- Turn the bulb holder [B] counterclockwise and remove it from headlight body.

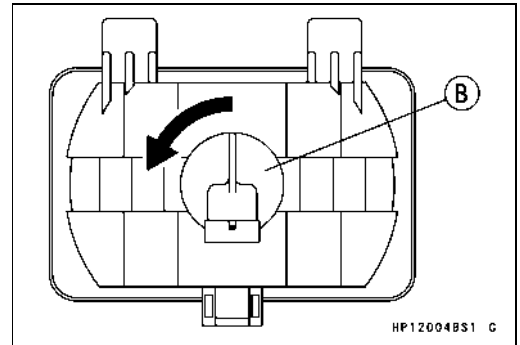
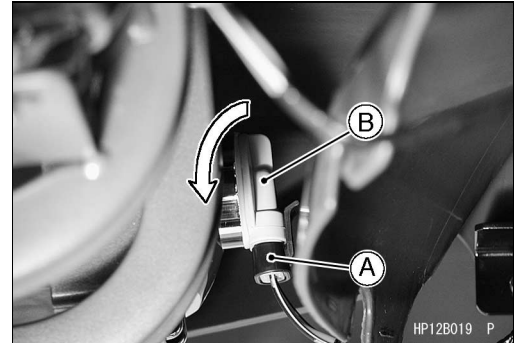

- Insert the bigger projection [A] of the bulb holder into the bigger hole [B] in the headlight body.

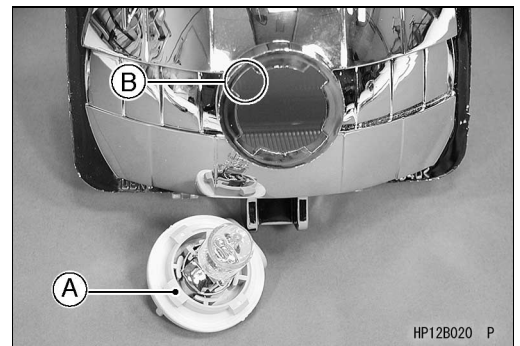

- Turn the bulb holder until it is contact the projection [A] to the stopper [B].
[C] Headlight Bulb

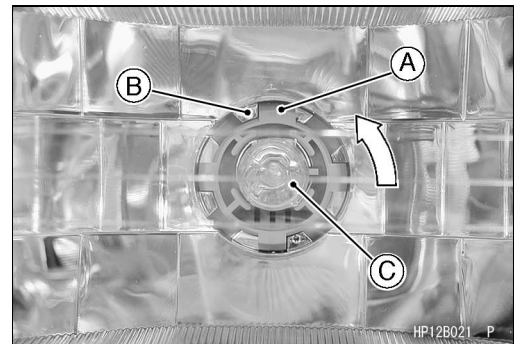

16-40 ELECTRICAL SYSTEM

Lighting System

Headlight Body Removal

- Remove:
 - Headlight Cover (see Frame chapter)
 - Headlight Beam Adjusting Screw [A] and Washer
- Pull the lower side of the headlight body forward and remove it.

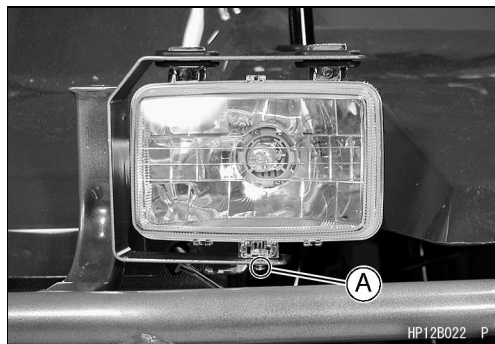

Headlight Body Installation

- Insert the tongues [A] on the headlight body into the grommets [B] in the bracket.
- Install:
 - Washer and Headlight Beam Adjusting Screw
- Connect:
 - Headlight Lead Connector

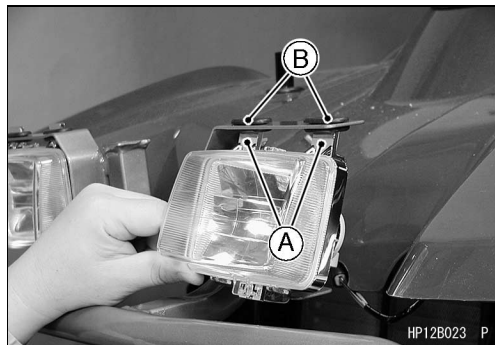

Taillight Bulb Replacement

- Remove:
 - Taillight Lens Mounting Screws [A]
 - Taillight Lens [B]

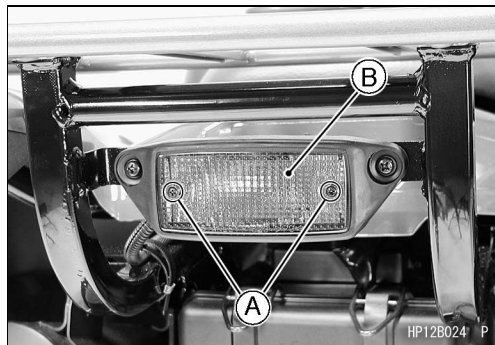

- Push the bulb [A] in, turn it counterclockwise, and pull it out.
- Be sure the socket is clean.

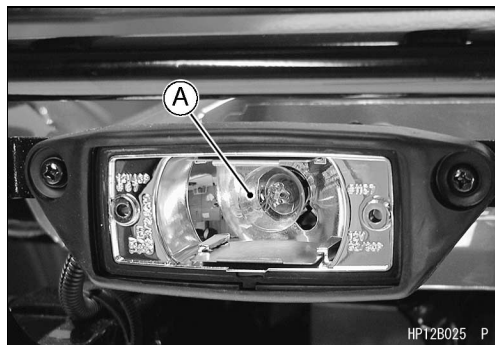

- Insert the new bulb by aligning the pins [A] with the grooves [B] in the walls of the socket.
- Push the bulb in, turn it clockwise, and release it. It should lock in position.

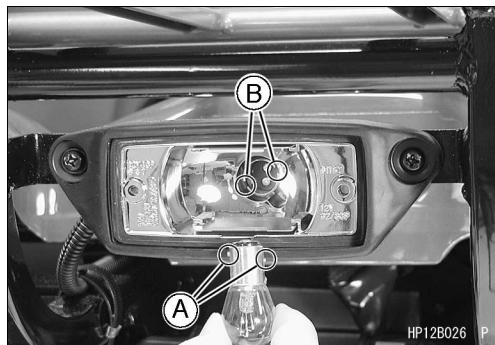

Lighting System

- Insert the projection [A] on taillight lens into the groove [B] in the taillight body.



16-42 ELECTRICAL SYSTEM

Lighting System

Lighting System Circuit

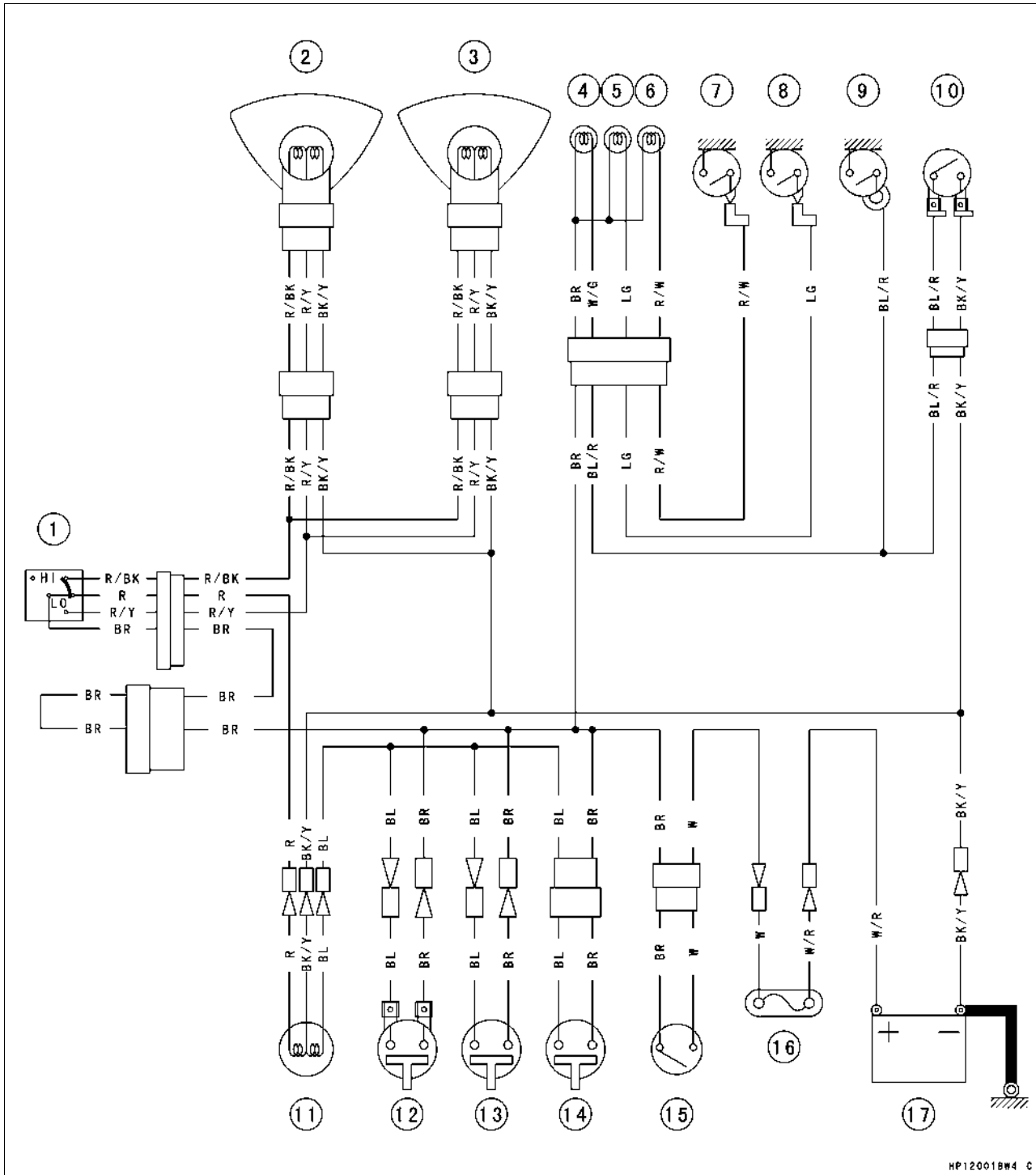

HP12001BW4 C

1. Light/Dimmer Switch
2. Headlight (Left)
3. Headlight (Right)
4. Oil Pressure/Temperature Warning Indicator Light
5. Neutral Indicator Light
6. Reverse Indicator Light
7. Reverse Switch
8. Neutral Switch
9. Oil Pressure Switch

10. Oil Temperature Switch
11. Tail/Brake Light
12. Front Brake Light Switch
13. Parking Brake Light Switch
14. Rear Brake Light Switch
15. Ignition Switch
16. Main Fuse 30 A
17. Battery

Oil Cooler Fan System

Oil Cooler Fan Circuit Inspection

- Remove the left front side cover (see Frame chapter).
- Disconnect the leads [A] from the oil cooler fan switch.
- Using an auxiliary wire, connect the oil cooler fan switch leads.
- ★ If the fan rotates, inspect the fan switch.
- ★ If the fan does not rotate, inspect the following.

- Leads and Connectors
- Main Fuse and Fan Fuse
- Fan Motor

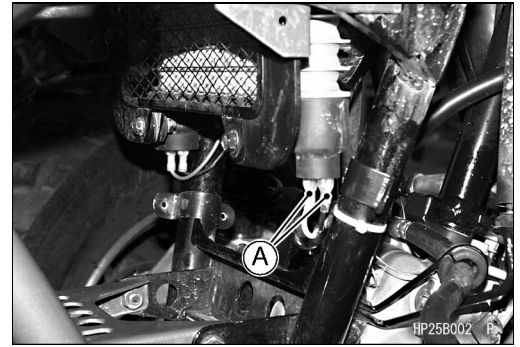

Oil Cooler Fan Motor Inspection

- Remove the Front Fender (see Frame chapter).
- Disconnect the connector [A] in the fan lead.
- Using two auxiliary wires, supply battery [B] voltage to the fan motor.
- ★ If the fan does not rotate, the fan motor is defective and must be replaced.

Oil Cooler Fan Motor Leads

- BL: Battery (+)
- BK: Battery (-)

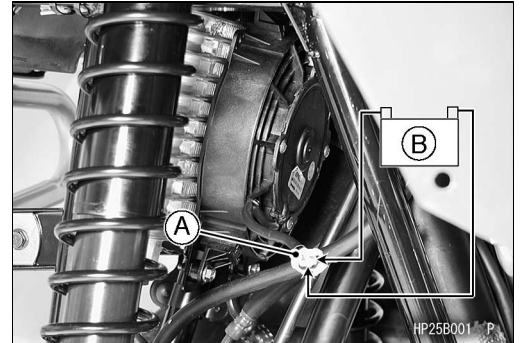

Oil Cooler Fan Circuit

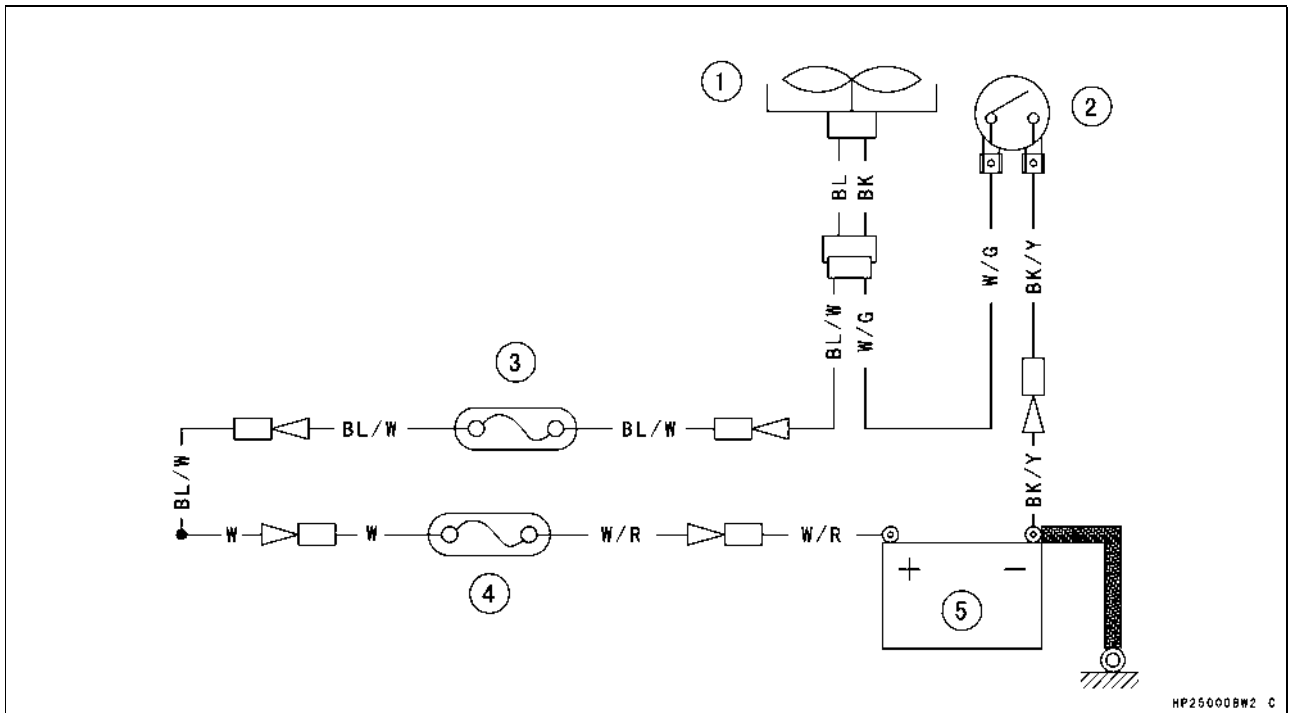

- 1. Oil Cooler Fan
- 2. Oil Cooler Fan Switch
- 3. Oil Cooler Fan Fuse 20A

- 4. Main Fuse 30A
- 5. Battery

16-44 ELECTRICAL SYSTEM

Speedometer (Optional Part for U.S. model)

Speedometer Removal

- Remove:
 - Front Fender (see Frame chapter)
 - Switch Housings
 - Brake Master Cylinder
 - Variable Differential Control Lever
 - Screws [A], Washers, and Collars



- Remove:
 - Nuts [A]
 - Bracket [B]
 - Rubber Damper and Speedometer

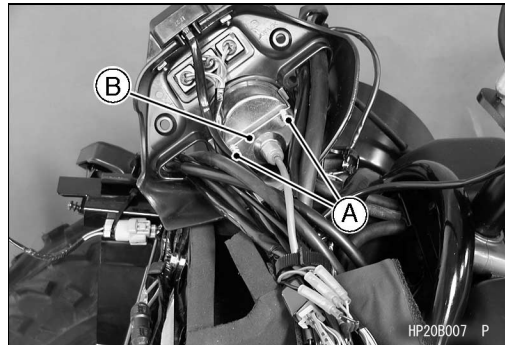

Speedometer Inspection

- Remove:
 - Speedometer (see Speedometer Removal)

CAUTION

Do not drop the meter unit.

- [1] Battery (Red)
- [2] Battery (Black)
- [3] Speed Sensor Pulse (Green)

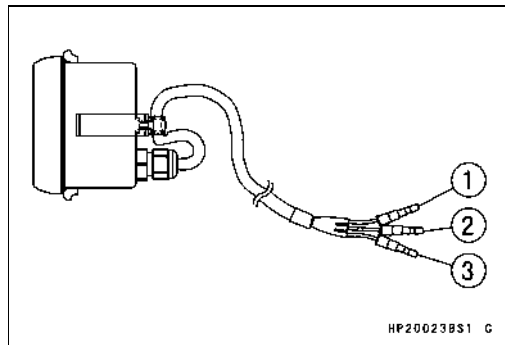

Check 1: Pointer and LCD Check

- Using auxiliary wires, connect a 12 V battery to the meter terminals as follows.
- Connect the battery negative (-) terminal to terminal [2] (Black).
- Connect the battery positive (+) terminal to terminal [1] (Red).

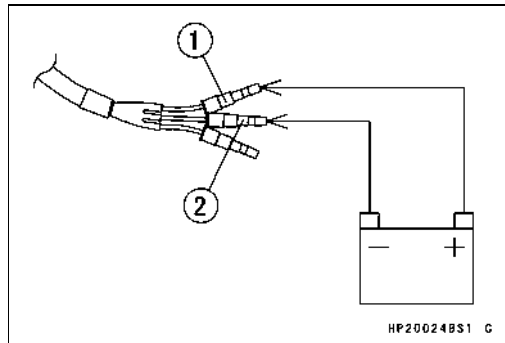

- The pointer will be move counterclockwise past "0" and then back up to "0".
- For the first second after power-up, the LCD display [A] will show the software revision # (i.e. 6801: r2, etc.).
- For the next four seconds, the accumulated hours will be shown.
- Finally, the LCD display will change to the current odometer reading (after a total of five seconds).

★ If this display function does not work, replace the meter unit.

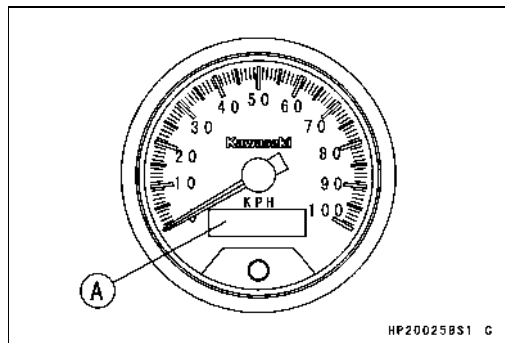

Speedometer (Optional Part for U.S. model)

Check 2: MODE Button Operation Check

- Connect the wires in the same manner as Check 1.
- Pushing the mode switch [A] briefly will toggle the LCD display [B] from "Odo" to "Trip", or visa versa (however; pushing the switch more often than once per second will not toggle the display).
- The trip count includes tenths of a mile, whereas the odo count does not.
- The trip mode may therefore be identified by the presence of a decimal point next to the "tenths" digit.
- To clear the trip count, push and hold the switch for at least three seconds (regardless of which mode the display is currently in) and do not let go until you see the trip count reset to zero.

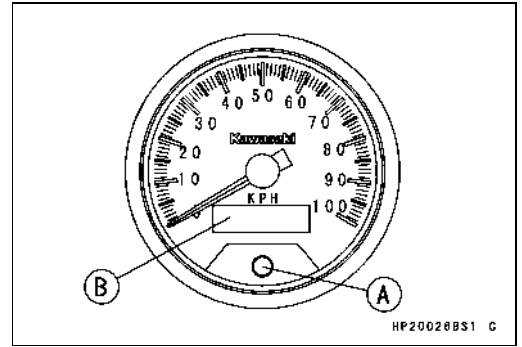

Check 3: Speedometer Check

- Connect the wires in the same manner as Check 1.
- The speed equivalent to the input frequency is indicated in the oscillator [A], if the square wave is input into terminal [3] (Green).
- Raise the input frequency of the oscillator to see the result of this inspection.
- ★ If the value indicated by the speedometer does not increase, replace the meter unit.

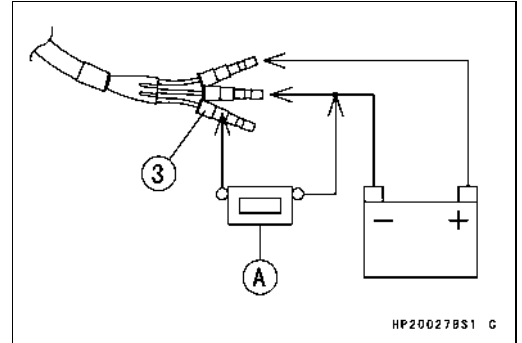

Check 4: Odometer Check

- Connect the wires in the same manner as Check 3.
- Pushing the mode switch [A], cycles the odometer [B].
- Raise the input frequency of the oscillator to see the result of this inspection.
- ★ If the value indicated by the odometer does not increase, replace the meter unit.

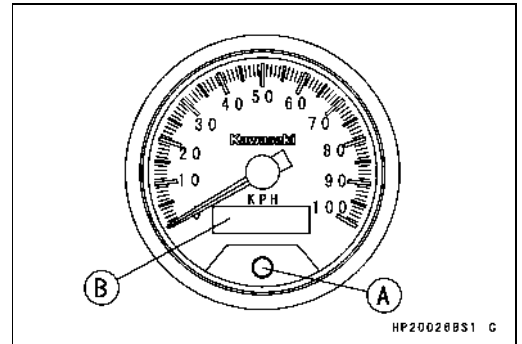

Check 5: Trip Meter Check

- Connect the wires in the same manner as Check 3.
- Pushing the mode switch [A], cycles the trip meter [B].
- Raise the input frequency of the oscillator to see the result of this inspection.
- ★ If the value indicated by the trip meter does not increase, replace the meter unit.

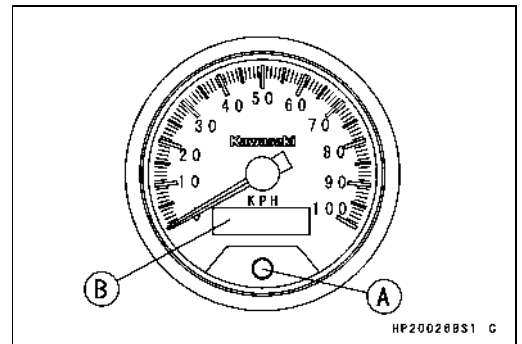

16-46 ELECTRICAL SYSTEM

Speedometer (Optional Part for U.S. model)

Speedometer Circuit

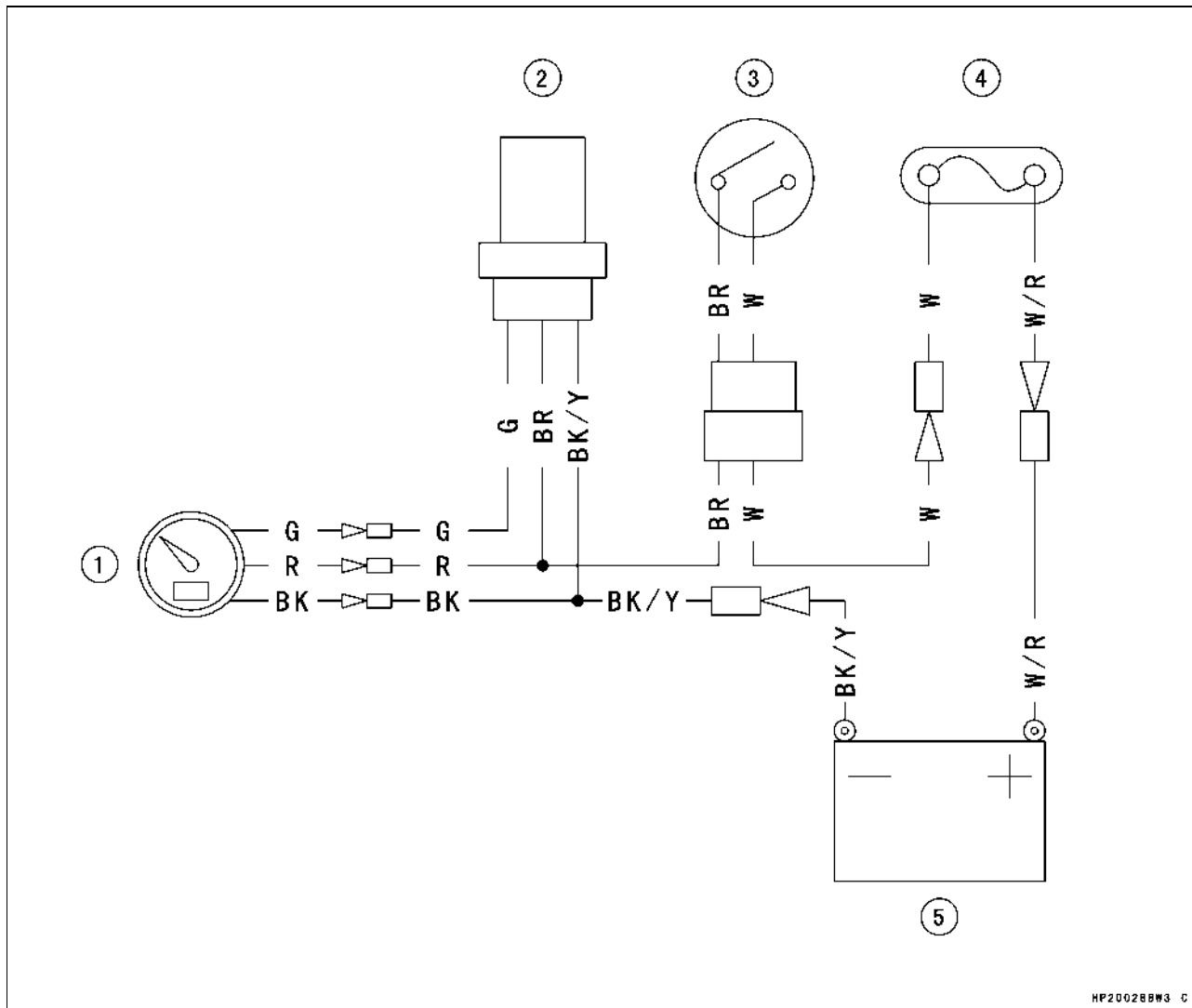

HP200288W3 C

1. Speedometer (except US model)
2. Speed Sensor
3. Ignition Switch
4. Main Fuse 30A
5. Battery

LED Indicator

Drive Belt Failure Mode Memory Clearing Procedure

A flashing CHECK BELT warning LED (Light Emitting Diode) light means that the drive belt needs inspection. The belt warning light will activate every 100 key-on hours, or sooner if the belt becomes damaged or fails.

NOTE

- Follow the instruction on pages 2–14 to 2–16 of this Service Manual to complete the necessary inspections.
- After completing the inspections, follow these instructions to clear the system memory and stop the flashing light.
- Turn off the ignition switch.
- Disconnect the belt switch at the 2 pin connector [A] above the torque converter cover.
- Disconnect both sets of 5 pin connectors [B] which are located above the torque converter cover.

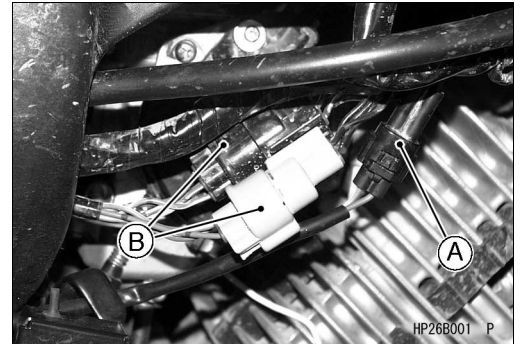

- Reconnect these 5 pin connectors to their opposite gray to black and black to gray.



- Turn on the ignition switch.
- Observe the belt warning light [A].
- It should be flashing at a 0.4 second interval.
- Let it flash for at least seven seconds.

NOTE

- More than seven seconds is OK.
- The 4WD LED light [B] will also flash only if 4WD is selected.
- While observing the belt warning light, turn off the ignition switch.



16-48 ELECTRICAL SYSTEM

LED Indicator

- Disconnect the mismatched 5 pin connector sets and reconnect them normally. (Black to black, gray to gray) [A]
- Connect the belt switch 2 pin connector [B].

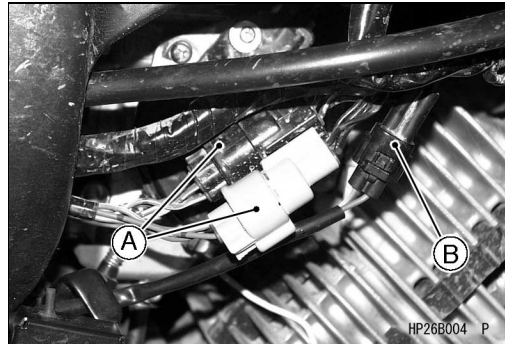

- Turn on the ignition switch.
- Confirm that no warning lights are flashing.
- The LED lights go on for one second.

LED Indicator Removal

- Remove:
 - Front Fender (see Frame chapter)
 - Handlebar Cover
- Disconnect:
 - LED Indicator Lead Connector [A]
- Remove:
 - Screws [B] and Collars
 - LED Indicator [C] and Bracket

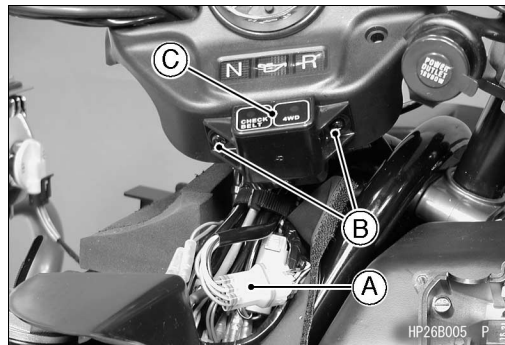

LED Indicator Installation

- Install:
 - Bracket [A]
 - LED Indicator [B]
 - Screws [C] and Collars [D]

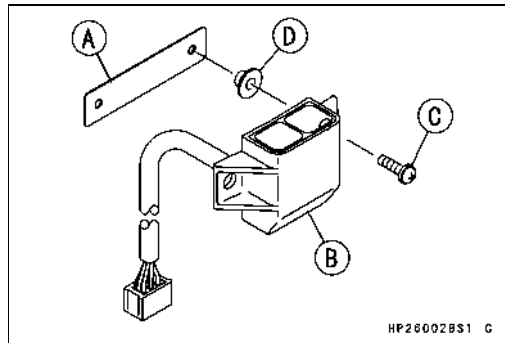

LED Indicator Inspection Flashing Pattern Inspection

LED Indicator

LED	Indication Pattern	Condition	Check
BELT and 4WD		Ignition Switch ON Normal	1
BELT and 4WD		Ignition Switch OFF Normal	2
BELT		Drive Failure Detecting Switch OFF (Belt Failure)	3
BELT		Total 100 hours of use	4
BELT and 4WD		Drive Belt Failure Mode Memory Clearing Procedure	5
BELT and 4WD		Ignition Switch OFF Memory Writing Failure	6
BELT		Memory Writing Time Limit (one hundred thousand)	7
BELT		Memory Reading Failure	8
4WD		2WD/4WD Actuator Failure	9
4WD		Engine Brake Actuator Failure	10
4WD		Both 2WD/4WD Actuator and Engine Brake Actuator Failure	11

16-50 ELECTRICAL SYSTEM

LED Indicator

Check 1

No Problem

Check 2

No Problem

Check 3

- Check the drive belt (see Drive Belt Deflection Inspection and Drive Belt Inspection in Periodic Maintenance chapter).
- ★ If it is flashed by abnormal belt, replace the belt and torque converter cover.
- After completing the inspections, do the drive belt failure mode memory clearing procedure (see Drive Belt Failure Mode Memory Clearing Procedure).

Check 4

- Check the drive belt (see Drive Belt Deflection Inspection and Drive Belt Inspection in Periodic Maintenance chapter).
- After completing the inspections, do the drive belt failure mode memory clearing procedure (see Drive Belt Failure Mode Memory Clearing Procedure).

Check 5

This flashing is the indication pattern for the drive belt failure mode memory clearing procedure.

Check 6

- The LED indicator may be broken.
- Do the drive belt failure mode memory clearing procedure.
- ★ If the same flashing appears, replace the LED indicator.

Check 7

The writing memory in the LED indicator is a limit (one hundred thousand times).

- Replace the LED indicator.

Check 8

- The LED indicator may be broken.
- Do the drive belt failure mode memory clearing procedure.
- ★ If the same flashing appears, replace the LED indicator.

Check 9, 10, 11

- See Actuator Control System Troubleshooting.

LED Indicator

LED Indicator External Circuit

1. LED Indicator
2. CHECK BELT LED
3. 4WD LED
4. Reset Connector
5. Battery
6. Ignition Switch
7. Drive Belt Failure Detecting Switch
8. Igniter
9. Input (from Drive Belt Failure Detecting Switch)
10. Output (to LED Indicator)
11. Actuator Controller
12. 2WD/4WD Shift Switch

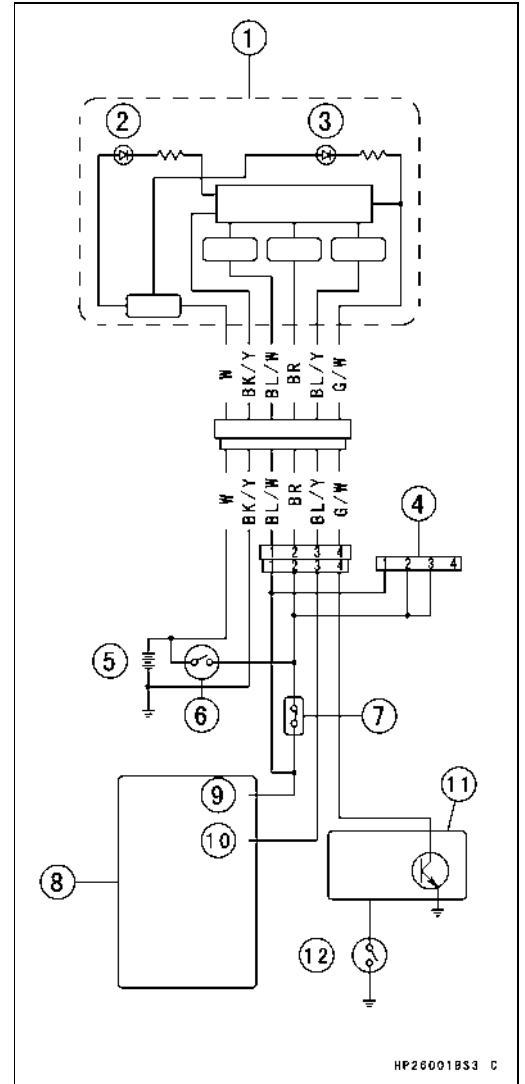

16-52 ELECTRICAL SYSTEM

LED Indicator

Led Indicator Circuit

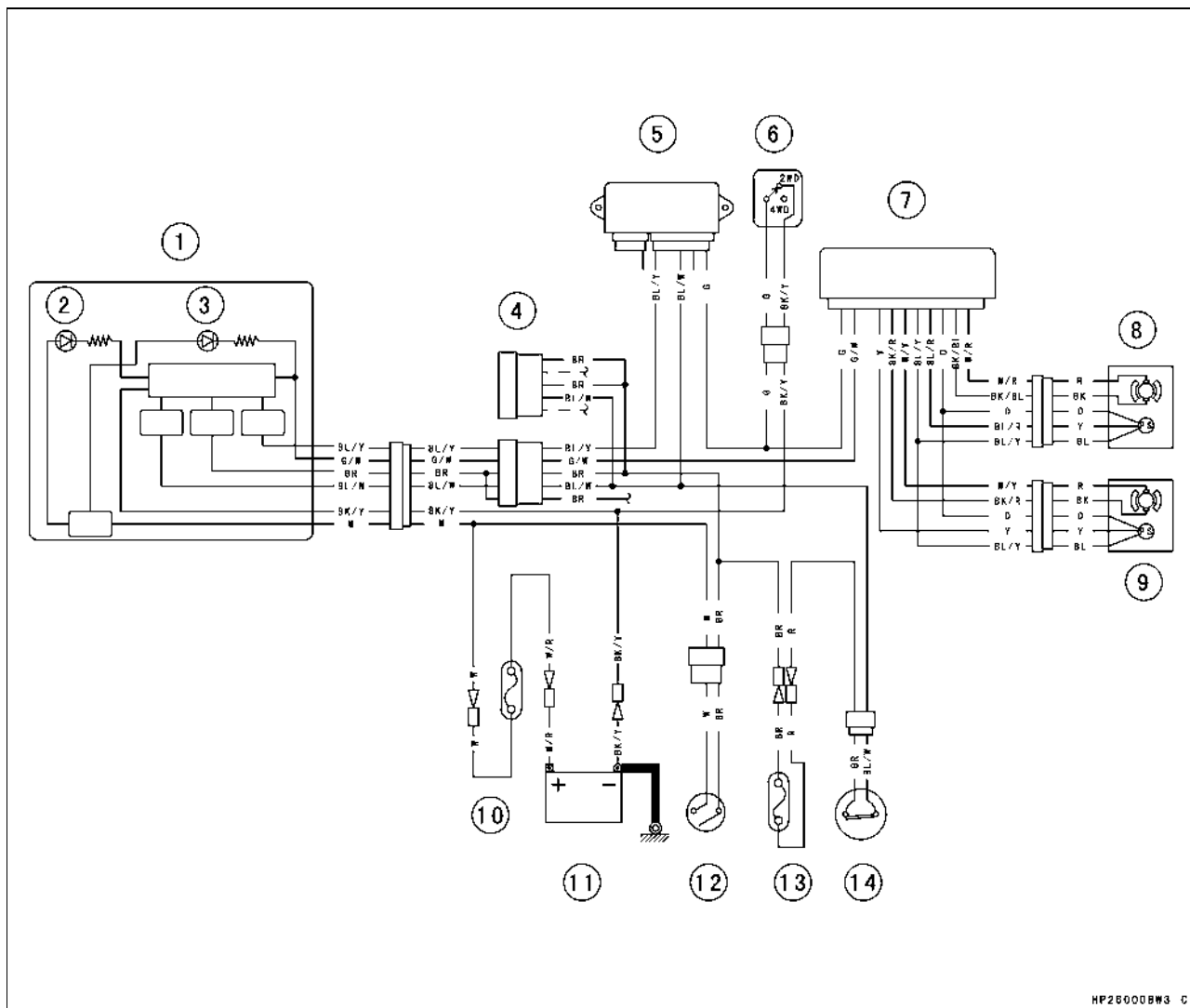

HP26008W3 C

- | | |
|--|--|
| 1. LED Indicator | 9. 2WD/4WD Actuator |
| 2. Drive Belt Failure Indicator LED (CHECK BELT) | 10. Battery |
| 3. 4WD Mode Indicator LED (4WD) | 11. Main Fuse 30A |
| 4. Drive Belt Failure Mode Reset Connector | 12. Ignition Switch |
| 5. Igniter | 13. Drive Belt Failure Detecting Switch
Fuse 5A |
| 6. 2WD/4WD Shift Switch | 14. Drive Belt Failure Detecting Switch |
| 7. Actuator Controller | |
| 8. Engine Brake Actuator | |

Actuator Control System

2WD/4WD Actuator Removal

- Remove:
 - Right Front Inner Cover (see Frame chapter)
 - Actuator Lead Connector [A]

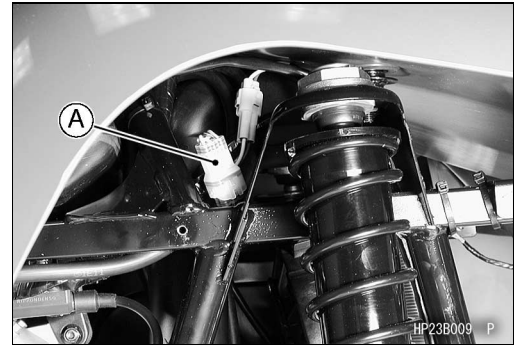

- Remove:
 - Breather Hose [A]
 - Actuator Mounting Bolts [B]
 - Actuator [C]

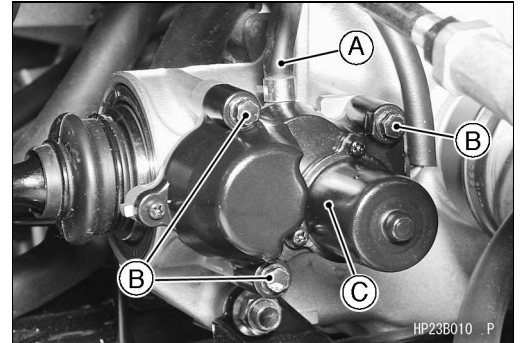

2WD/4WD Actuator Installation

- When installing the pin [A], install the collar [B] on the actuator and then press the pin.
- Visually inspect the collar.
- ★ If the collar is damaged or worn excessively, replace it.
- Apply grease to the O-ring [C].
- Insert the collar into the groove [D] of the shifter so that the long side [E] faces downward.

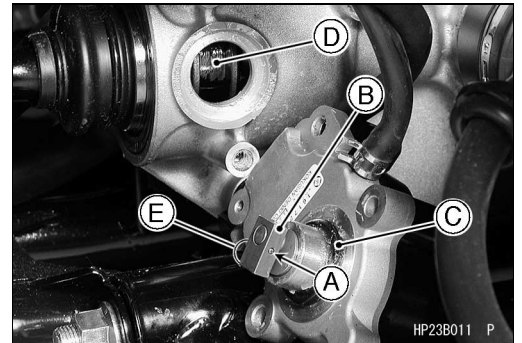

- Apply a non-permanent locking agent to the actuator mounting bolts, and tighten them following the tightening sequence [1 ~ 3].

Torque - 2WD/4WD Actuator Mounting Bolts: 9.8 N·m (1.0 kgf·m, 87 in·lb)

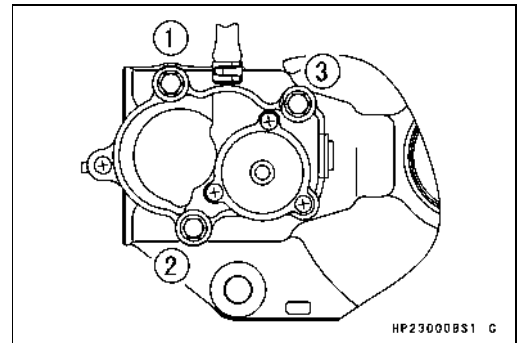

Engine Brake Actuator Removal

- Remove:
 - Actuator Lead Connector [A]

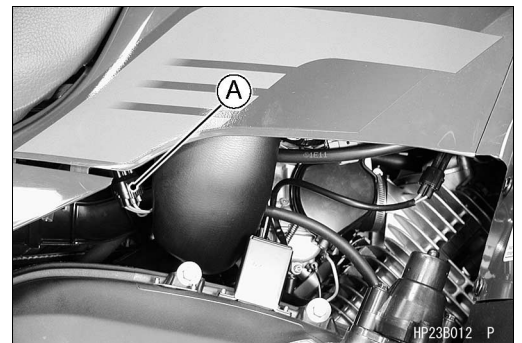

16-54 ELECTRICAL SYSTEM

Actuator Control System

- Remove:
 - Actuator Mounting Bolts [A]
 - Actuator [B]

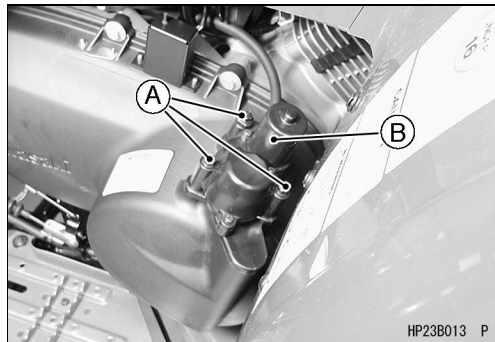

Engine Brake Actuator Installation

- Apply grease to the O-ring [A] and install it.
- Apply molybdenum disulfide grease to the pin [B].
- Insert the pin into the collar [C] of the engine brake lever assembly [D].
- Tighten:
 - Torque - Engine Brake Actuator Mounting Bolts: 8.8 N-m (0.9 kgf-m, 78 in-lb)**
- Wipe off any protruding grease.

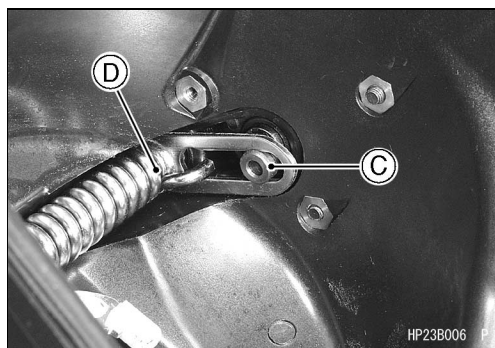
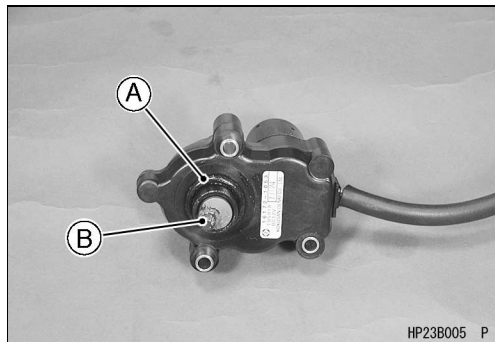

Actuator Control System Outline

The actuator controller [A] has a microprocessor that detects vehicle speed, state of the selectable 2WD/4WD shift switch, ignition switch, and the forward/reverse movement of the vehicle in order to control the engine brake actuator and selectable 2WD/4WD actuator.

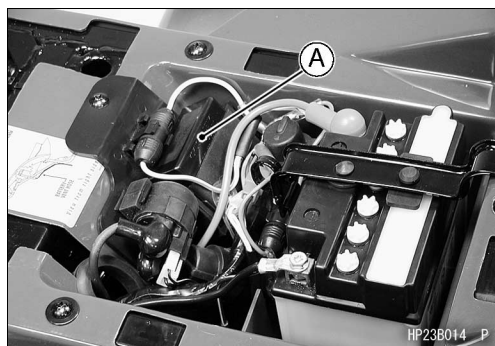

Actuator Control System

Actuator Control System

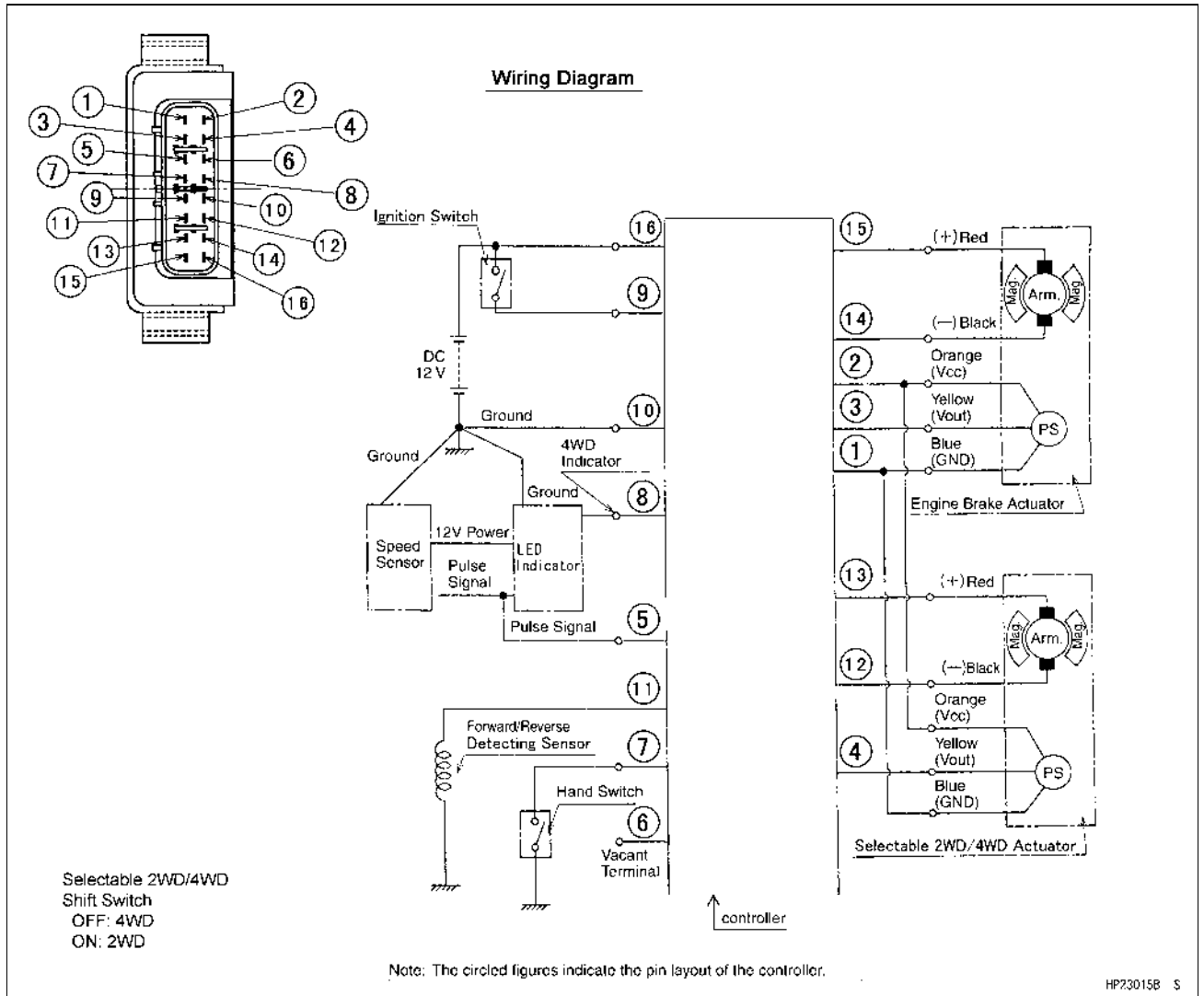

16-56 ELECTRICAL SYSTEM

Actuator Control System

Actuator Control System Troubleshooting

When the actuator fails, the controller enters failure mode and the 4WD indicator light (LED) [A] is flash.



Failure Indication Pattern and Failure Part

No.	Failure Indication Pattern (4WD Indicator Light)	Failure Part
1		Selectable 2WD/4WD actuator
2		Engine brake actuator
3		Both the selectable 2WD/4WD actuator and the engine brake actuator

Malfunction Mode

No.	Malfunction Mode	Probable Faulty Part/Location	Check Number
1	The 2WD/4WD actuator does not operate correctly.	2WD/4WD actuator Controller power supply Speed sensor 2WD/4WD shift switch Controller	1 3 4 5 6
2	The engine brake actuator does not operate correctly.	Engine brake actuator Controller power supply Speed sensor F/R detecting sensor Controller	2 3 4 7 6
3	The 4WD indicator light does not switch.	2WD/4WD shift switch Controller LED indicator light	5 6 8

Actuator Control System

Check 1. 2WD/4WD Actuator Inspection

- Remove:
 - Right Front Inner Cover (see Frame chapter)
 - Actuator Lead Connector [A]

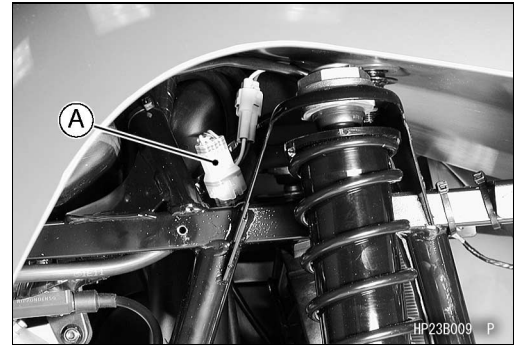

- Measure the resistance between the following terminals in the actuator lead connector [A].

Special Tool - Hand Tester: 57001-1394

Actuator Internal Resistance

4 (Red) – 6 (Black):	3 ~15 Ω
1 (Orange) – 3 (Blue):	3.5 ~6.5 kΩ
2 (Yellow) – 3 (Blue):	630 ~3,720 Ω

- ★ If any reading is not within the specified range, replace the 2WD/4WD actuator.
- ★ If the reading is within the specified range, inspect the position of the actuator output shaft as following procedure.

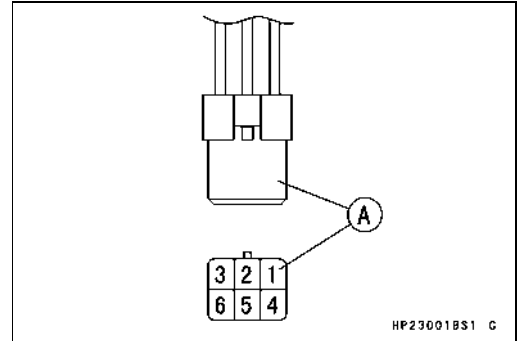

- Remove:
 - 2WD/4WD Actuator (see 2WD/4WD Actuator Removal)
- Check if the output shaft [A] position is within the inoperative angle range [F] as shown in the figure.
 - [A] Actuator Output Shaft
 - [B] 2WD Point
 - [C] 4WD Point
 - [D] Operative Range Angle = 109.5 deg.
 - [E] Angle = 45.6 deg.
 - [F] Inoperative Range Angle = 91.2 deg.
 - [G] Actuator Lead Connector

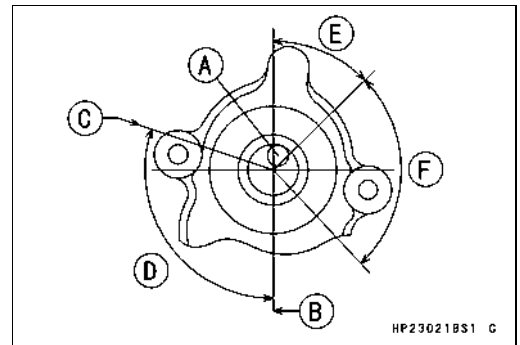

- ★ If the output shaft is in the inoperative range angle, move the shaft in the operative range angle.
- Apply the 12 V battery voltage to the actuator.
 - Battery (+) → Connector 4 terminal (Red)
 - Battery (-) → Connector 6 terminal (Black)
- Stop applying the power when the output shaft comes near the 2WD point [B].
- Install the actuator (see 2WD/4WD Actuator Installation).
- ★ If the output shaft is in the operative range angle, the malfunction of the 2WD/4WD actuator could be caused by other parts.

Check 2. Engine Brake Actuator Inspection

- Remove:
 - Actuator Lead Connector [A]

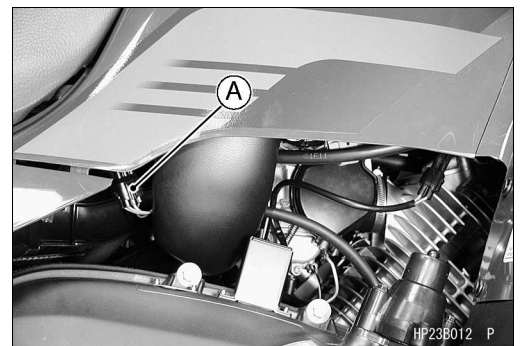

16-58 ELECTRICAL SYSTEM

Actuator Control System

- Measure the resistance between the following terminals in the actuator lead connector [A].

Special Tool - Hand Tester: 57001-1394

Actuator Internal Resistance

4 (Red) – 6 (Black):	3 ~15 Ω
1 (Orange) – 3 (Blue):	3.5 ~6.5 k Ω
2 (Yellow) – 3 (Blue):	630 ~5,330 Ω

- ★ If any reading is not within the specified range, replace the engine brake actuator.
- ★ If the reading is within the specified range, inspect the position of the actuator output shaft as following procedure.

- Remove:

Engine Brake Actuator (see Engine Brake Actuator Removal)

- Check if the output shaft [A] position is within the inoperative angle range [G] as shown in the figure.

[A] Actuator Output Shaft

[B] Angle = 51.4 deg.

[C] Starting Point

[D] Ending Point

[E] Operative Range Angle = 180 deg.

[F] Angle = 7 deg.

[G] Inoperative Range Angle = 91.2 deg.

[H] Actuator Lead Connector

- ★ If the output shaft is in the inoperative angle range, move the shaft in the operative angle range.
- Apply the 12 V battery voltage to the actuator.
Battery (+) → Connector 4 terminal (Red)
Battery (-) → Connector 6 terminal (Black)
- Stop applying the power when the output shaft comes near the starting point [C].
- Install the actuator (see Engine Brake Actuator Installation).
- ★ If the output shaft is in the operative angle range, the engine brake malfunction could be caused by other parts.

Check 3. Controller Power Supply Inspection

NOTE

- Be sure the battery is fully charged.

- Remove:

Seat (see Frame chapter)

- Connect:

Controller Connector [A]

Hand Tester [B] (range: DC 25 V)

Tester (+) → Connector (BR) Terminal [9]

Tester (-) → Connector (BK/Y) Terminal [10]

- Install the needle adapters on the tester leads.

Special Tools - Hand Tester: 57001-1394

Needle Adapter Set: 57001-1457

- Turn ON the ignition switch.

Controller Power Supply Voltage

Standard: near Battery Voltage

- ★ If the reading is not battery voltage, check the wiring harness, 30 A fuse, or ignition switch.

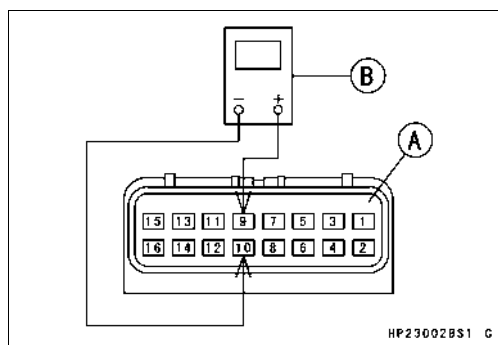
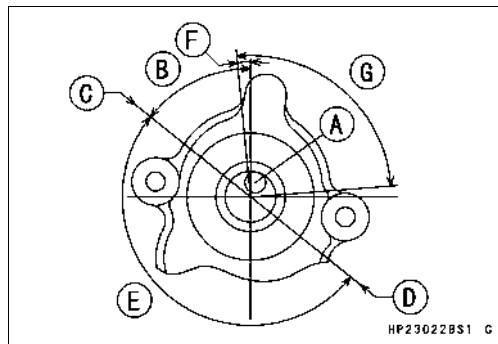
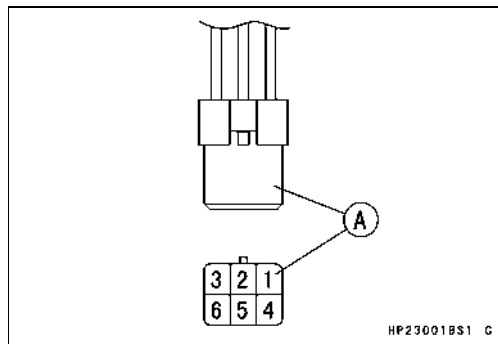

Actuator Control System

Check 4. Speed Sensor Inspection

NOTE

- *Be sure the battery is fully charged.*
- Support the vehicle on a stand or a jack so that the wheels are off the ground.
- Remove:
 - Seat (see Frame chapter)
- Connect:
 - Controller Connector [A]
 - Hand Tester [B] (range: DC 25 V)
 - Tester (+) → Connector (P) Terminal [5]
 - Tester (–) → Connector (BK/Y) Terminal [10]
- Install the needle adapters on the tester leads.

Special Tools - Hand Tester: 57001–1394
Needle Adapter Set: 57001–1457

- Turn ON the ignition switch.
- Spin a rear wheel, measure the voltage.

Speed Sensor Output Voltage

Standard: repeat from 0 to 5 V

- ★ If the reading is not standard, replace the speed sensor.

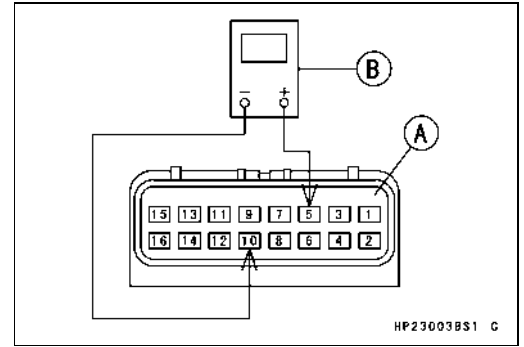

Check 5. 2WD/4WD Shift Switch Inspection

NOTE

- *Be sure the battery is fully charged.*
- Remove:
 - Seat (see Frame chapter)
- Connect:
 - Controller Connector [A]
 - Hand Tester [B] (range: DC 25 V)
 - Tester (+) → Connector (G) Terminal [7]
 - Tester (–) → Connector (BK/Y) Terminal [10]
- Install the needle adapters on the tester leads.

Special Tools - Hand Tester: 57001–1394
Needle Adapter Set: 57001–1457

- Turn ON the ignition switch.
- Push the switch to the 4WD position.

Controller Output Voltage (at 2WD/4WD Shift Switch OFF, 4WD)

Standard: about 5 V

- ★ If the reading is not standard, check the 2WD/4WD shift switch or actuator controller unit.
- Push the switch to the 2WD position.

Controller Output Voltage (at 2WD/4WD Shift Switch ON, 2WD)

Standard: 0 V

- ★ If the reading is not standard, check the 2WD/4WD shift switch or actuator controller unit.

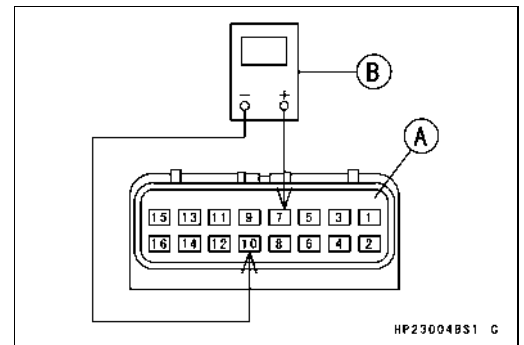

16-60 ELECTRICAL SYSTEM

Actuator Control System

Check 6. Controller Unit Inspection

NOTE

- Be sure the battery is fully charged.

- Remove:
 - Seat (see Frame chapter)
- Connect:
 - Controller Connector [A]
 - Hand Tester [B] (range: DC 10 V)
 - Tester (+) → Connector (O) Terminal [2]
 - Tester (-) → Connector (BK/Y) Terminal [10]
- Install the needle adapters on the tester leads.

Special Tools - Hand Tester: 57001-1394
Needle Adapter Set: 57001-1457

- Turn ON the ignition switch.
- Measure the controller output voltage for the actuators.

Controller Output Voltage (to Actuators)
Standard: 4.8 ± 0.2 V

- ★ If the reading is not standard, replace the actuator controller unit.

- Disconnect the speed sensor lead connector.
- Connect:
 - Controller Connector [A]
 - Hand Tester [B] (range: DC 10 V)
 - Tester (+) → Connector (P) Terminal [5]
 - Tester (-) → Connector (BK/Y) Terminal [10]
- Install the needle adapters on the tester leads.

Special Tools - Hand Tester: 57001-1394
Needle Adapter Set: 57001-1457

- Turn ON the ignition switch.
- Measure the controller output voltage for the speed sensor.

Controller Output Voltage (to speed sensor)
Standard: 5 ± 0.25 V

- ★ If the reading is not standard, replace the actuator controller unit.

- Disconnect the 2WD/4WD shift switch lead connector.
- Connect:
 - Controller Connector [A]
 - Hand Tester [B] (range: DC 10 V)
 - Tester (+) → Connector (G) Terminal [7]
 - Tester (-) → Connector (BK/Y) Terminal [10]
- Install the needle adapters on the tester leads.

Special Tools - Hand Tester: 57001-1394
Needle Adapter Set: 57001-1457

- Turn ON the ignition switch.
- Measure the controller output voltage for the 2WD/4WD shift switch.

Controller Output Voltage (to 2WD/4WD shift switch)
Standard: 5 ± 0.25 V

- ★ If the reading is not standard, replace the actuator controller unit.

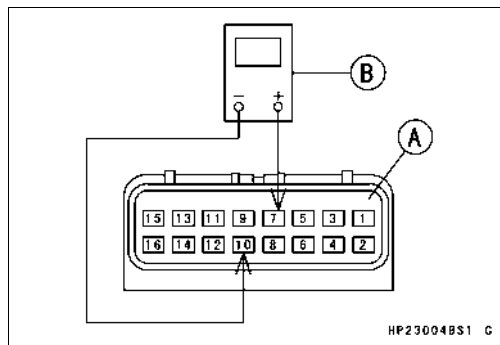
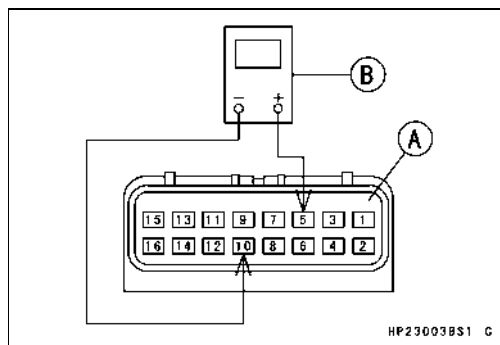
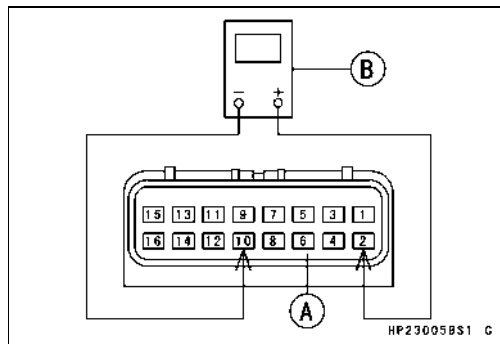

Actuator Control System

- Support the vehicle on a stand or a jack so that the wheels are off the ground.
- Connect:
 - Controller Connector [A]
 - Hand Tester [B] (range: DC 25 V)
 - Tester (+) → Connector (W/R) Terminal [15]
 - Tester (-) → Connector (BK/Y) Terminal [10]
- Install the needle adapters on the tester leads.

Special Tools - Hand Tester: 57001-1394
Needle Adapter Set: 57001-1457

- Turn ON the ignition switch.
- Spin a rear wheel as forward rotation.
- After the wheels stop and one second elapses, turn OFF the ignition switch.
- After two seconds elapses, measure the controller output voltage for the engine brake actuator until the actuator stops.

Controller Output Voltage (to engine brake actuator)

Standard: 5 ~ 12 V

- ★ If the reading is not standard, check the forward/reverse detecting sensor.
- ★ If the forward/reverse detecting sensor is normal, replace the actuator controller unit.

- Support the vehicle on a stand or a jack so that the wheels are off the ground.
- Run the engine and shift to the 4WD position.
- Stop the engine and turn OFF the ignition switch.
- Connect:
 - Controller Connector [A]
 - Hand Tester [B] (range: DC 25 V)
 - Tester (+) → Connector (W/Y) Terminal [12]
 - Tester (-) → Connector (BK/Y) Terminal [10]
- Install the needle adapters on the tester leads.

Special Tools - Hand Tester: 57001-1394
Needle Adapter Set: 57001-1457

- Turn ON the ignition switch.
- Shift to the 2WD position.
- Measure the controller output voltage for the 2WD/4WD actuator until the actuator stops.

Controller Output Voltage (to 2WD/4WD actuator)

Standard: 5 ~ 12 V

- ★ If the reading is not standard, check the 2WD/4WD shift switch.
- ★ If the 2WD/4WD shift switch is normal, replace the actuator controller unit.

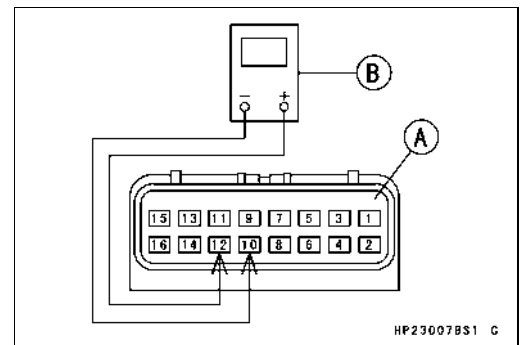
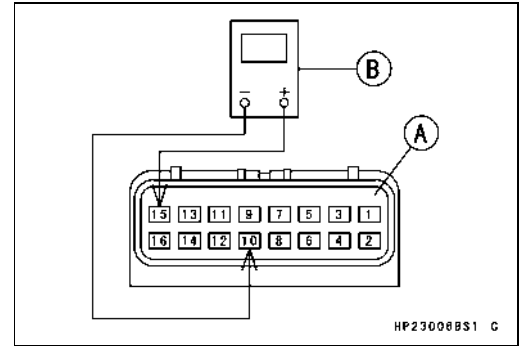

16-62 ELECTRICAL SYSTEM

Actuator Control System

Check 7. Forward/Reverse Detecting Sensor Inspection

- Remove:
 - Left Side Cover (see Frame chapter)
- Disconnect forward/reverse detecting sensor lead wire connector [A].
- Measure the forward/reverse detecting sensor resistance.
- Connect the hand tester between the BK lead and the W lead.
- Set the tester to the $\times k\Omega$ range.

Special Tool - Hand Tester: 57001-1394

Forward/Reverse Detecting Sensor Resistance

Standard: 1.2 ~ 1.6 k Ω

- ★ If the reading is not within the specified range, replace the forward/reverse detecting sensor [B].
- Using the highest resistance, measure the resistance between forward/reverse detecting sensor leads and chassis ground.
- ★ If the tester reading is less than infinity (∞) indicates a short, replace the forward/reverse detecting sensor.

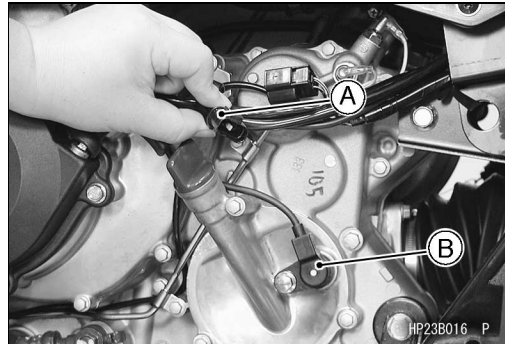

Check 8. Indicator Light (LCD) Inspection

NOTE

- Be sure the battery is fully charged.
- Remove:
 - Seat (see Frame chapter)
- Connect:
 - Controller Connector [A]
 - Hand Tester [B] (range: DC 25 V)
 - Tester (+) → Connector (G/W) Terminal [8]
 - Tester (-) → Connector (BK/Y) Terminal [10]
- Install the needle adapters on the tester leads.

Special Tool - Hand Tester: 57001-1394

Needle Adapter Set: 57001-1457

- Turn ON the ignition switch.
- Push the switch to the 4WD position and shift the vehicle to 4WD mode.
 - Controller Output Voltage (to LED Indicator)
 - Standard: about 5 V
- ★ If the reading is not standard, check the 2WD/4WD shift switch.
- ★ If the 2WD/4WD shift switch is normal, replace the actuator controller unit.
- ★ Even if the reading is standard, when the 4WD light does not go on, replace the LED indicator.

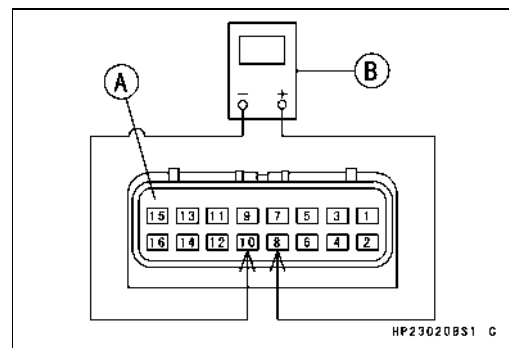

16-64 ELECTRICAL SYSTEM

Drive Belt Failure Detection System

If the drive belt failure detection system is activated by abnormal belt, the drive belt failure detection switch is damaged. Make sure replace the torque converter cover (see Converter System chapter).

Drive Belt Failure Detection System Inspection

- Remove:
 - Fuel Tank Cover (see Frame chapter)
- Check the drive belt failure detection system according to following chart.

Drive Belt Failure Detection System

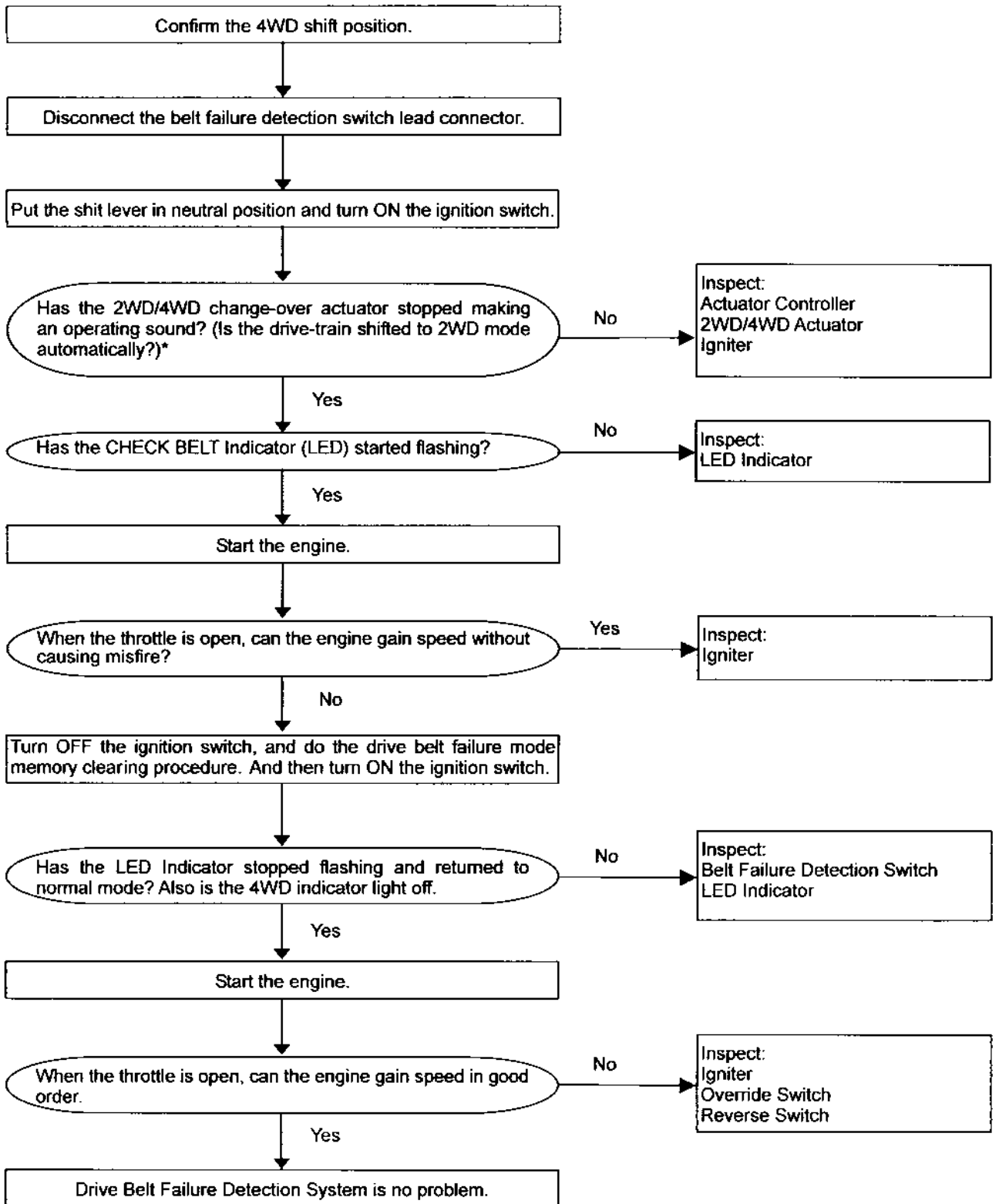

*: If (2WD/4WD change-over) the actuator keeps making a sound, try move the vehicle back and forth a little. This will help the actuator disconnect the drive train.

16-66 ELECTRICAL SYSTEM

Drive Belt Failure Detection System

Drive Belt Failure Detection System Circuit

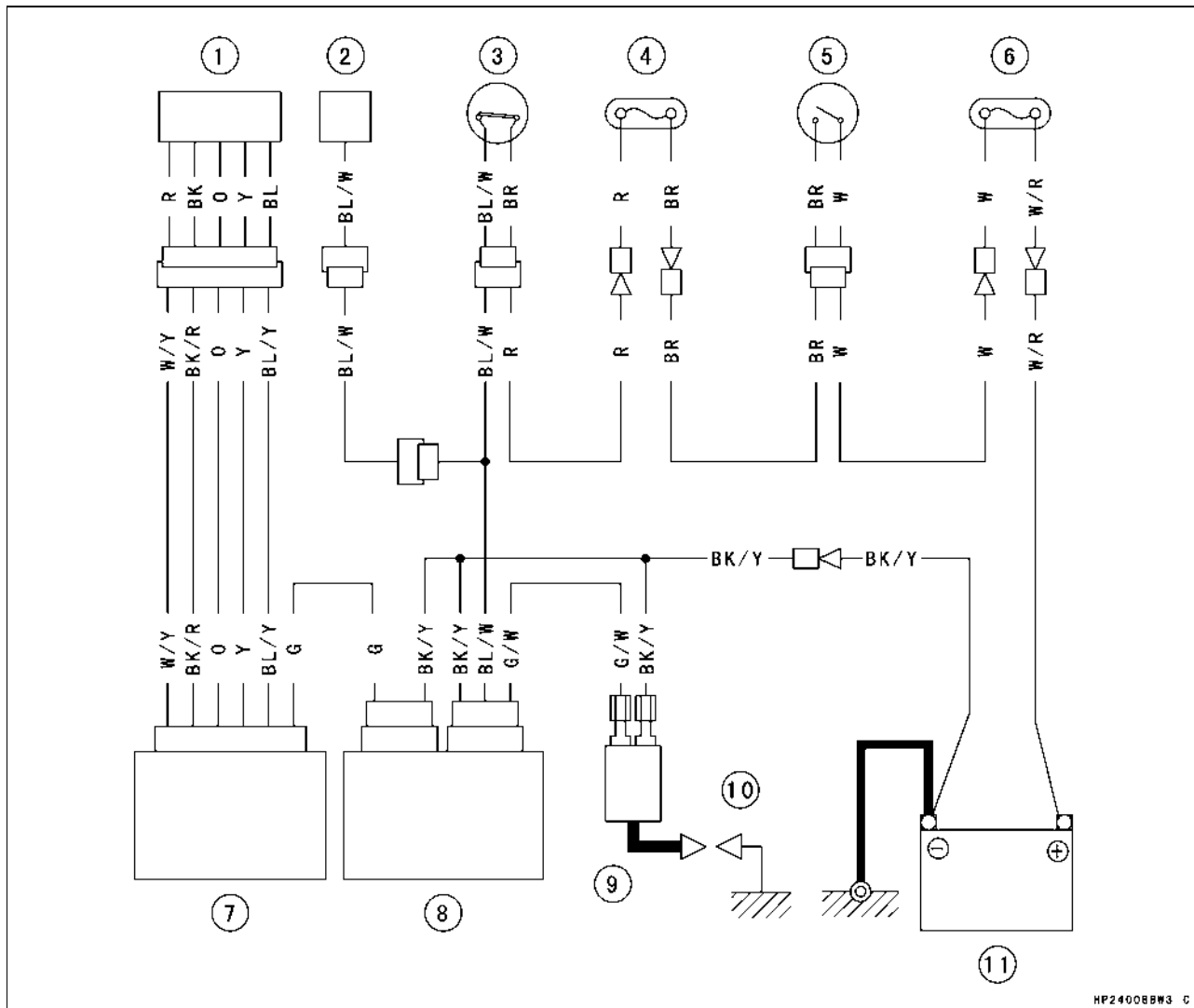

HP24008BW3 C

- | | |
|--|------------------------|
| 1. 2WD/4WD Actuator | 7. Actuator Controller |
| 2. LED Indicator | 8. Igniter |
| 3. Drive Belt Failure Detecting Switch | 9. Ignition Coil |
| 4. Drive Belt Failure Detecting Switch Fuse 5A | 10. Spark Plug |
| 5. Ignition Switch | 11. Battery |
| 6. Main Fuse 30A | |

Carburetor Heater System

Air Temperature Sensor Inspection

- Remove:
 - Seat (see Frame chapter)
 - Air Temperature Sensor [A]

 - Connect the battery and hand tester to the sensor.
 - Red Connector [A]
 - White Connector [B]
 - 12 V Battery [C]
 - Hand Tester [D]
- Special Tool - Hand Tester: 57001-1394**

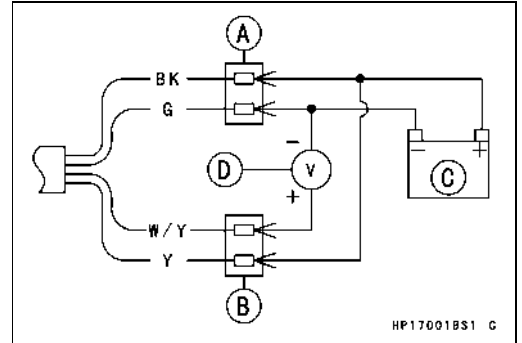
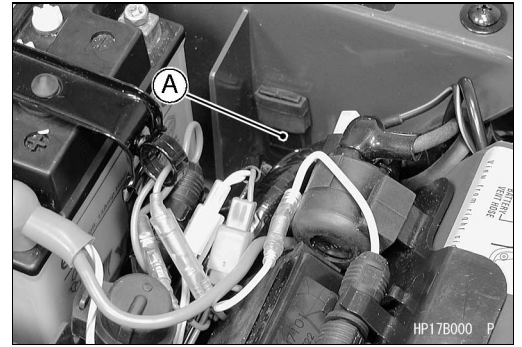

CAUTION

Use the sensor within $-30 \sim 80^{\circ}\text{C}$ ($-22 \sim 176^{\circ}\text{F}$). If it is used without the specified range, the sensor will be damaged.

- Suspend the sensor [A] in a container of cold water of less than 8°C (46.4°F) so that the temperature sensing part [B] is submerged as shown.
 - [C] Ice
- Suspend an accurate thermometer [D] in the water.
- Measure the output voltage between W/Y terminal and battery (-) terminal (tester range: DC 25 V).

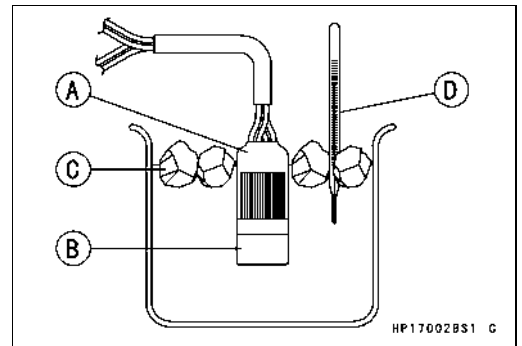

Air Temperature Sensor: less than 8°C (46.4°F)
Output Voltate: 8 ~ 16 V (near battery voltage)

- ★ If the voltage is less than DC 0.1 V, replace the sensor.
- Warm up the sensor [A] more than 22°C (71.6°F) with a hand.
- Measure the output voltage between W/Y terminal and battery (-) terminal (tester range: DC 2.5 V).

Air Temperature Sensor: more than 22°C (71.6°F)
Output Voltate: less than 0.1 V

- ★ If the voltage is 8 ~ 16 V, replace the sensor.

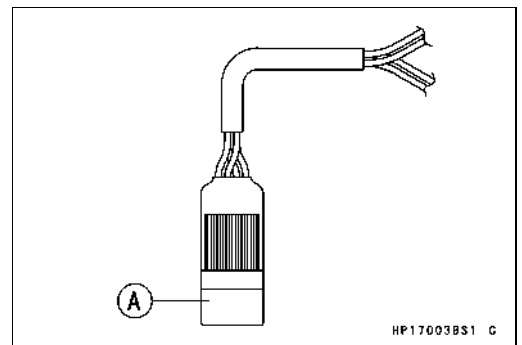

16-68 ELECTRICAL SYSTEM

Carburetor Heater System

Carburetor Heater Inspection

- Disconnect:
 - Carburetor Heater Lead Connector [A]
 - Ground Lead Connector [B]
- Using the hand tester, measure the resistance of the heater.
- Connect the tester between the heater terminal and the ground terminal.

★ If the tester does not read as specified, replace the heater.

Carburetor Heater Resistance

11 ~ 20 Ω

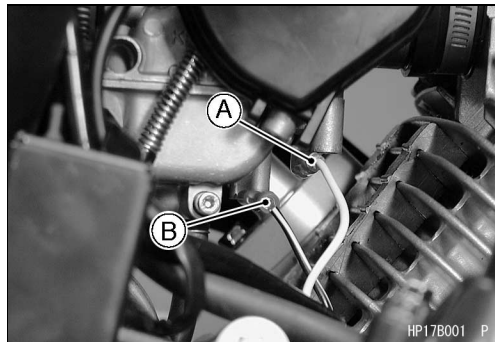

Carburetor Heater System Circuit

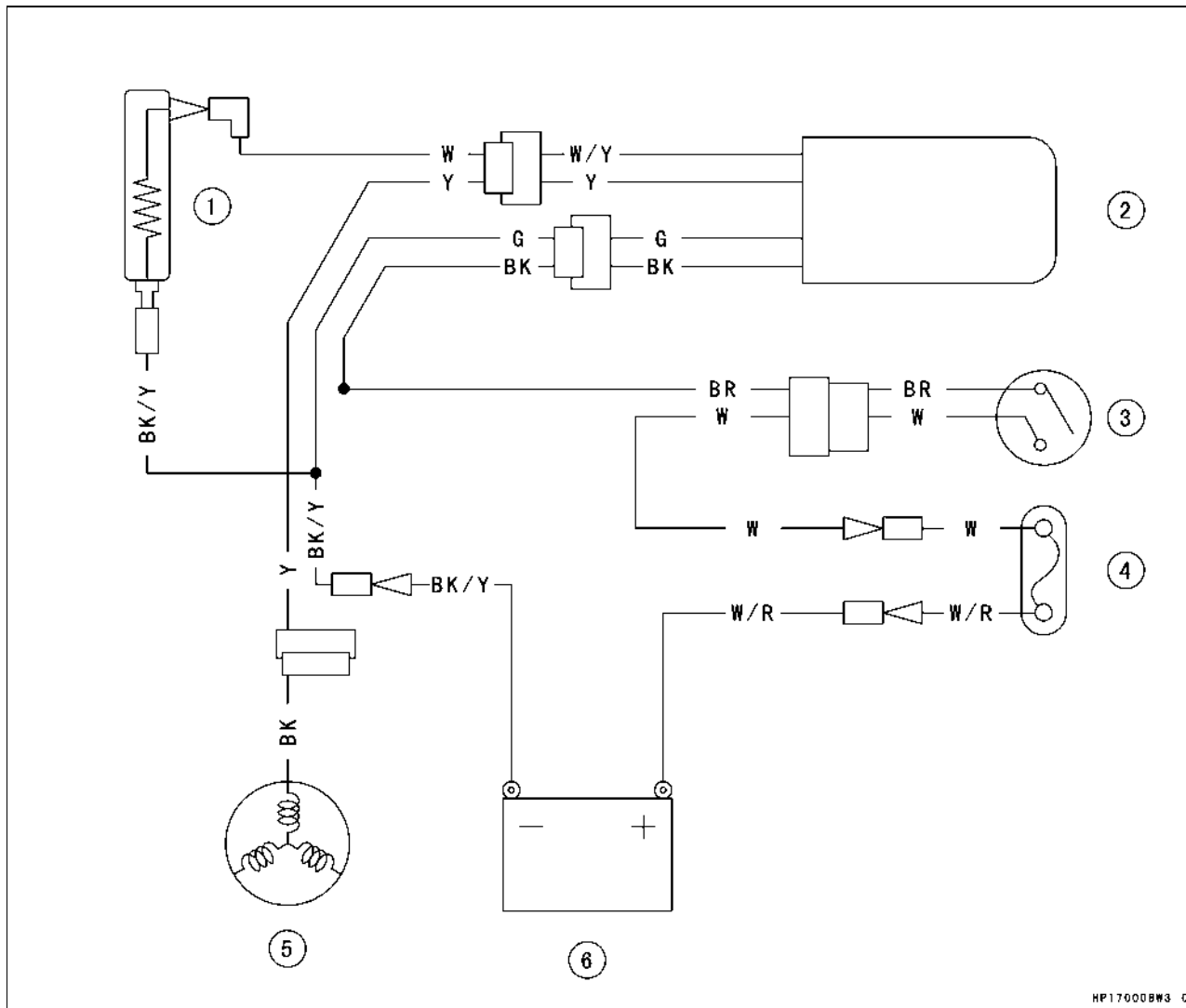

1. Carburetor Heater 12V23W
2. Air Temperature Sensor
3. Ignition Switch

4. Main Fuse 30A
5. Alternator
6. Battery

Switches

Brake Light Switch Adjustment

- Refer to Brake Light Switch Adjustment in Periodic Maintenance chapter.

Oil Cooler Fan Switch Inspection

- Remove:
 - Oil Cooler Fan Switch (see Engine Lubrication System chapter)
- Suspend the fan switch [A] in a container of oil so that the temperature sensing projection and threaded portion are submerged.
- Suspend an accurate thermometer [B] in the oil.

NOTE

- *The switch and thermometer must not touch the container sides or bottom.*
- Place the container over a source of heat and gradually raise the temperature of the oil while stirring the oil gently.
- Using the hand tester, measure the internal resistance of the switch across the terminals at the temperatures shown in the table.
- ★ If the hand tester does not show the specified values, replace the switch.

Oil Cooler Fan Switch Resistance

- **Rising temperature:**
 - From OFF to ON at 67 ~ 73°C (153 ~ 163°F)
- **Falling temperature:**
 - From ON to OFF at 57 ~ 63°C (135 ~ 145°F)
 - ON: Less than 0.5 Ω
 - OFF: More than 1 MΩ

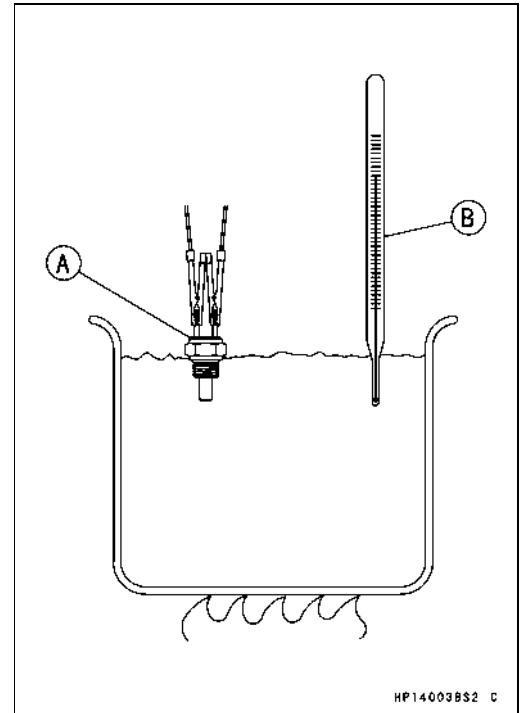

Oil Temperature Warning Light Switch Inspection

- Remove:
 - Oil Temperature Warning Light Switch (see Engine Lubrication System chapter)
- Suspend the switch [A] in a container of oil so that the temperature sensing projection and threaded portion are submerged.
- Suspend an accurate thermometer [B] in the oil.

NOTE

- *The switch and thermometer must not touch the container sides or bottom.*
- Place the container over a source of heat and gradually raise the temperature of the oil while stirring the oil gently.
- Using the hand tester, measure the internal resistance of the switch across the terminals at the temperatures shown in the table.
- ★ If the hand tester does not show the specified values, replace the switch.

Oil Temperature Warning Light Switch Resistance

- **Rising temperature:**
 - From OFF to ON at 107 ~ 113°C (225 ~ 235°F)
- **Falling temperature:**
 - From ON to OFF at 97 ~ 103°C (207 ~ 217°F)
 - ON: Less than 0.5 Ω
 - OFF: More than 1 MΩ

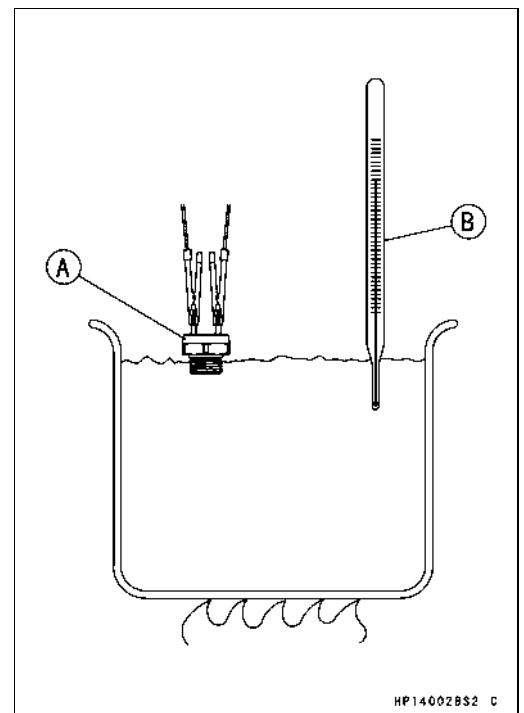



Switch Inspection

- Using the hand tester, check to see that only the connections shown in the table have continuity (about zero ohms).
- For the handlebar switches, ignition switch, refer to tables in the Wiring Diagram.
- ★ If the switch has an open or short, repair or replace it with a new one.

16-70 ELECTRICAL SYSTEM



Switches

Neutral Switch Connection

	SW.Terminal	
When transmission is in neutral		
When transmission is not in neutral		

[A] Neutral Switch

Reverse Switch Connections



	SW.Terminal	
When transmission is in reverse		
When transmission is not in reverse		

[B] Reverse Switch

2WD/4WD Shift Switch

	G	BK/Y
2WD Position		
4WD Position		

Oil Pressure Switch Connections*

	SW. Terminal	
When engine is stopped		
When engine is running		

*: Engine lubrication system is in good condition

Drive Belt Failure Detection Switch

If the drive belt failure detection system is activated by abnormal belt, the drive belt failure detection switch is damaged. Make sure to replace the torque converter cover (see Converter System chapter).

● Remove:

Torque Converter Cover (see Torque Converter Removal section in Converter System)

	BR	BL/W
When drive belt failure detection switch is in ON position		
When drive belt failure detection switch is in OFF position		

[A] Drive Belt Failure Detection Switch

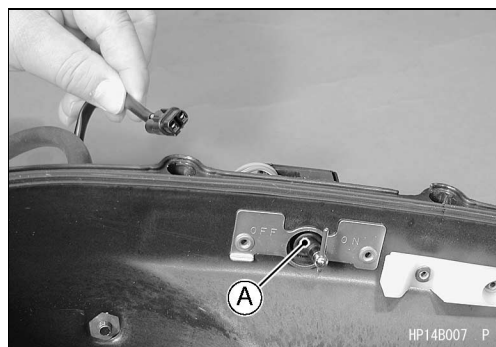
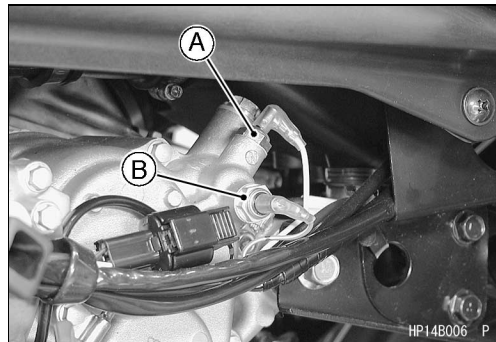

Fuses

Fuses Removal

- Remove:
 - Seat (see Frame chapter)
 - Fuse Cap [A]
 - Fuse [B]

- Remove:
 - Main Fuse 30A [A]
 - Accessory Fuse 5A [B]

- Remove:
 - Oil Cooler Fan Fuse 20A [A]
 - Drive Belt Failure Detecting Switch Fuse 5A [B]

[C] Oil Cooler

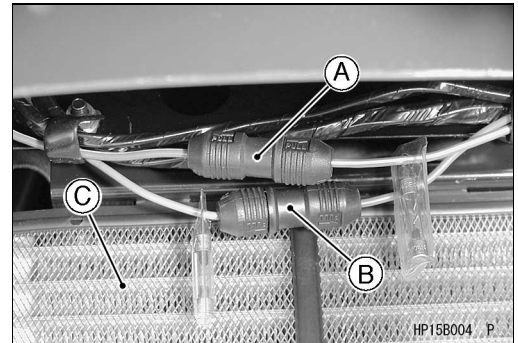
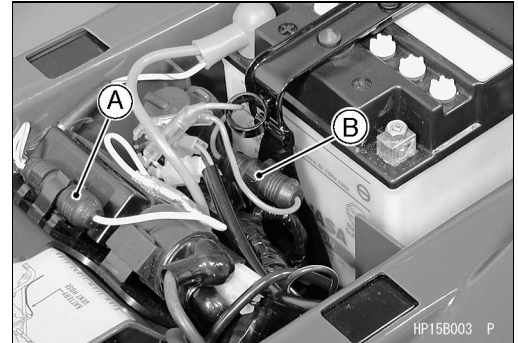
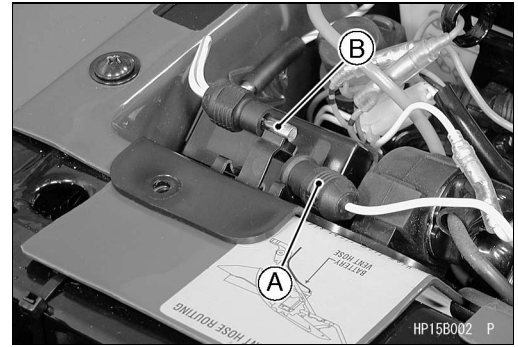

Fuse Inspection

- Inspect the fuse element [A].
- ★ If it is blown out, replace the fuse. Before replacing a blown fuse [B], always check the amperage in the affected circuit. If the amperage is equal to or greater than the fuse rating, check the wiring and related components for a short circuit.

CAUTION

When replacing a fuse, be sure the new fuse matches the specified fuse rating for that circuit. Installation of a fuse with a higher rating may cause damage to wiring and components.

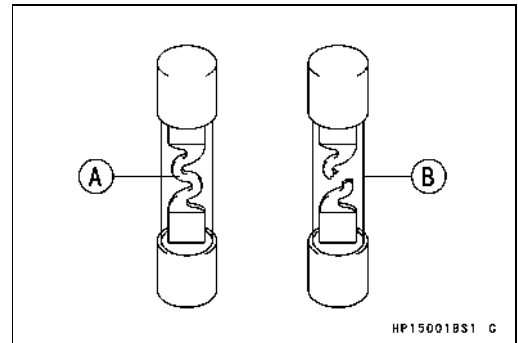

16-72 ELECTRICAL SYSTEM

Wiring Diagram

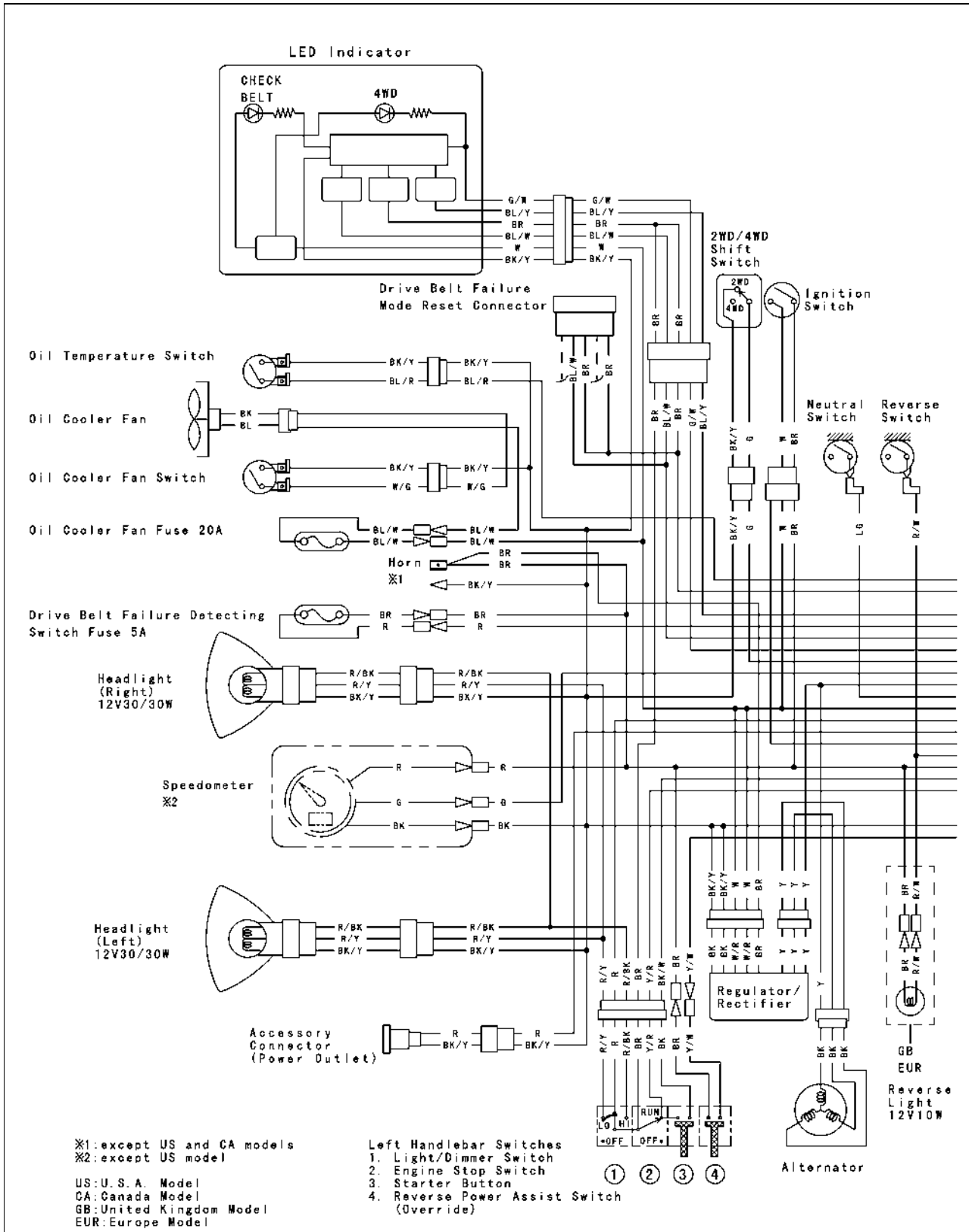

Light/Dimmer Switch					Engine Stop Switch			Starter Button			Reverse Power Assist Switch		
Color	R/Y	R	R/BK	BR	Color	BR	Y/R	Color	Y/R	BK	Color	BR	Y/W
OFF					OFF			Released			OFF		
LO	●	●	●	●				Push	●	●	ON	●	●
HI	●	●	●	●	RUN	●	●						

Wiring Diagram

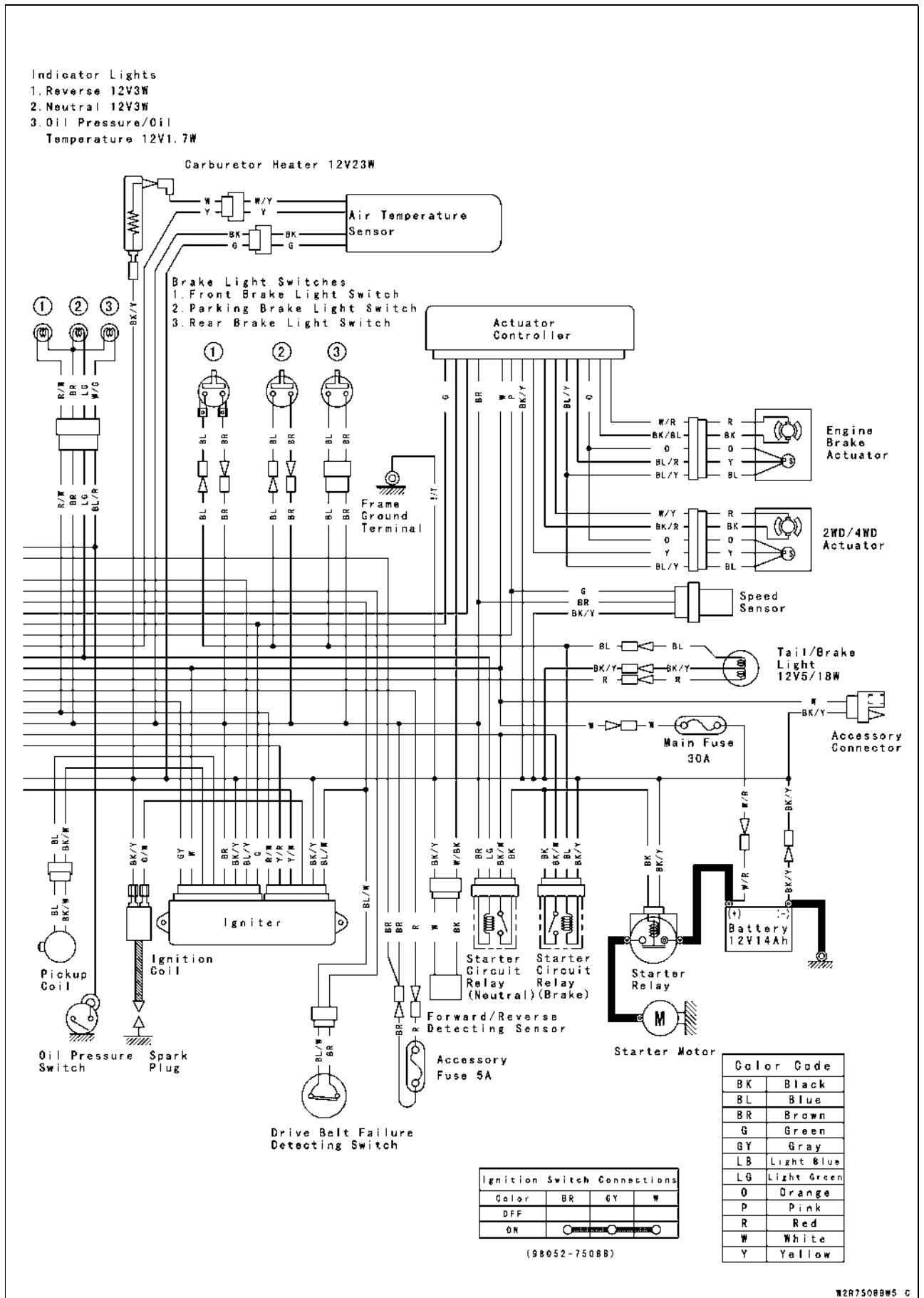

Appendix

Table of Contents

Troubleshooting Guide	17-2
Cable, Wire, and Hose Routing	17-6

17-2 APPENDIX

Troubleshooting Guide

NOTE

- *This is not an exhaustive list, giving every possible cause for each problem listed. It is meant simply as a rough guide to assist the troubleshooting for some of the more common difficulties.*

Engine Doesn't Start, Starting Difficulty:

Starter motor not rotating:

- Neutral switch trouble
- Starter motor trouble
- Battery voltage low
- Relays not contacting or operating
- Starter button not contacting
- Wiring open or shorted
- Ignition switch trouble
- Engine stop switch trouble
- Fuse blown

Starter motor rotating but engine doesn't turn over:

- Starter motor clutch trouble

Recoil starter not operating

- Recoil starter spring broken
- Recoil starter pawl not engaging

Engine won't turn over:

- Valve seizure
- Rocker arm seizure
- Cylinder, piston seizure
- Crankshaft seizure
- Connecting rod small end seizure
- Connecting rod big end seizure
- Transmission gear or bearing seizure
- Camshaft seizure
- Balancer bearing seizure

No fuel flow:

- Fuel tank air vent obstructed
- Fuel tap clogged
- Fuel line clogged
- Float valve clogged

Engine flooded:

- Fuel level too high
- Float valve worn or stuck open
- Starting technique faulty
(When flooded, crank the engine with the throttle fully opened to allow more air to reach the engine.)

Fuel/air mixture incorrect:

- Pilot screw and/or idle adjusting screw maladjusted
- Pilot jet or air passage clogged
- Air cleaner clogged, poorly sealed, or missing
- Starter jet clogged

No spark; spark weak:

- Spark plug dirty, broken, or maladjusted
- Spark plug cap or spark plug lead trouble
- Spark plug cap not in good contact
- Spark plug incorrect
- Pickup coil trouble
- Igniter trouble
- Ignition coil trouble
- Battery voltage low
- Ignition or engine stop switch shorted
- Wiring shorted or open
- Fuse blown

Compression Low:

- Spark plug loose
- Cylinder head not sufficiently tightened down
- No valve clearance

- Cylinder, piston worn
- Piston ring bad (worn, weak, broken, or sticking)
- Piston ring/groove clearance excessive
- Cylinder head gasket damaged
- Cylinder head warped
- Valve spring broken or weak
- Valve not seating properly (valve bent, worn, or carbon accumulation on the seating surface)
- Compression release cam (K.A.C.R.) sticks open
(Engine stalls when moving off)

Poor Running at Low Speed:

Spark weak:

- Spark plug dirty, broken, or maladjusted
- Spark plug cap or spark plug lead trouble
- Spark plug cap shorted or not in good contact
- Spark plug incorrect
- Igniter trouble
- Pickup coil trouble
- Ignition coil trouble
- Battery voltage low

Fuel/air mixture incorrect:

- Pilot screw and/or idle adjusting screw maladjusted
- Pilot jet or air passage clogged
- Starter plunger stuck open
- Air cleaner clogged, poorly sealed, or missing
- Fuel level too high or too low
- Fuel tank air vent obstructed
- Carburetor holder loose
- Air cleaner duct loose

Compression low:

- Spark plug loose
- Cylinder head not sufficiently tightened down
- No valve clearance
- Cylinder, piston worn
- Piston ring bad (worn, weak, broken, or sticking)
- Piston ring/groove clearance excessive
- Cylinder head gasket damaged
- Cylinder head warped
- Valve spring broken or weak
- Valve not seating properly (valve bent, worn, or carbon accumulation on the seating surface)
- Compression release cam (K.A.C.R.) sticks open
(Engine stalls when moving off)

Other:

- Carburetor vacuum piston doesn't slide smoothly
- Engine oil viscosity too high
- Brake dragging
- Igniter trouble
- Front or rear final gear case oil viscosity too high

Poor Running or No Power at High Speed:

Firing incorrect:

- Spark plug dirty, broken, or maladjusted
- Spark plug cap or spark plug lead trouble
- Spark plug cap shorted or not in good contact
- Spark plug incorrect
- Pickup coil trouble
- Igniter trouble
- Ignition coil trouble
- Drive belt failure detection switch activated

Troubleshooting Guide

Fuel/air mixture incorrect:

- Main jet clogged or wrong size
- Jet needle or needle jet worn
- Main air jet clogged
- Bleed holes of air bleed pipe or needle jet clogged
- Fuel level too high or too low
- Air cleaner clogged, poorly sealed, or missing
- Starter plunger stuck open
- Water or foreign matter in fuel
- Carburetor holder loose
- Air cleaner duct loose
- Fuel tank air vent obstructed
- Fuel tap clogged
- Fuel line clogged

Compression low:

- Spark plug loose
- Cylinder head not sufficiently tightened down
- No valve clearance
- Cylinder, piston worn
- Piston rings bad (worn, weak, broken, or sticking)
- Piston ring/groove clearance excessive
- Cylinder head gasket damaged
- Cylinder head warped
- Valve spring broken or weak
- Valve not seating properly (valve bent, worn, or carbon accumulation on the seating surface.)
- Compression release cam (K.A.C.R.) sticks open (Engine stalls when moving off)

Knocking:

- Carbon built up in combustion chamber
- Fuel poor quality or incorrect
- Spark plug incorrect
- Igniter trouble

Miscellaneous:

- Throttle valve won't fully open
- Carburetor vacuum piston doesn't slide smoothly
- Brake dragging
- Overheating
- Engine oil level too high
- Engine oil viscosity too high
- Balancer mechanism malfunctioning
- Front or rear final gear case oil viscosity too high

Overheating:**Firing incorrect:**

- Spark plug dirty, broken, or maladjusted
- Spark plug incorrect
- Igniter trouble

Fuel/air mixture incorrect:

- Main jet clogged
- Fuel level too low
- Carburetor holder loose
- Air cleaner poorly sealed, or missing
- Air cleaner duct loose
- Air cleaner clogged

Compression high:

- Carbon built up in combustion chamber
- Compression release cam sticks close (K.A.C.R.)

Engine load faulty:

- Engine oil level too high
- Engine oil viscosity too high
- Drive train trouble
- Brake dragging

Lubrication inadequate:

- Engine oil level too low
- Engine oil poor quality or incorrect

Front or rear final gear case overheating:

- Insufficient oil
- Bevel gears maladjusted
- LSD clutches in front final gear case maladjustment

Oil cooler incorrect:

- Oil cooler clogged
- Oil cooler fan switch trouble
- Fan motor broken
- Fan blade damaged

Converter Operation Faulty:**Belt slipping:**

- Belt dirty, worn, or wetted
- Drive or driven pulley sheave dirty or worn
- Drive pulley spring broken or weak

Converter engagement speed too low:

- Drive pulley spring broken or weak

Converter engagement speed too high:

- Belt dirty or worn
- Drive or driven pulley sheave dirty or worn
- Drive pulley weight doesn't move smoothly
- Drive pulley movable sheave doesn't move smoothly
- Drive or driven pulley movable sheave bush worn
- Drive pulley weight or roller worn

Shifting too quickly:

- Drive pulley spring weak
- Driven pulley spring weak or incorrectly installed (too loose)

Shifting too slowly:

- Belt dirty or worn
- Drive or driven pulley sheave dirty or worn
- Drive pulley weight doesn't move smoothly
- Drive pulley movable sheave doesn't move smoothly
- Drive pulley spring incorrect installed (too tight)
- Driven pulley movable sheave doesn't move smoothly

Gear Shifting Faulty:**Doesn't go into gear:**

- Shift arm bent or seized
- Gear stuck on the shaft
- Shift tie-rod maladjusted
- Shift tie-rod damaged

Jumps out of gear:

- Shifter groove worn
- Gear dogs worn
- Shift block worn
- Shift arm positioning bolt spring weak or broken
- Shift tie-rod maladjusted
- Drive shaft, output shaft, and/or gear splines worn

Overshifts:

- Shift arm positioning bolt spring weak or broken
- Shift tie-rod maladjusted

17-4 APPENDIX

Troubleshooting Guide

Abnormal Engine Noise:

Knocking:

- Igniter trouble
- Carbon built up in combustion chamber
- Fuel poor quality or incorrect
- Spark plug incorrect
- Overheating

Piston Slap:

- Cylinder/piston clearance excessive
- Cylinder, piston worn
- Connecting rod bent
- Piston pin, piston holes worn

Valve noise:

- Valve clearance incorrect
- Valve spring broken or weak
- Camshaft bearing worn
- Rocker arm worn

Other noise:

- Connecting rod small end clearance excessive
- Connecting rod big end clearance excessive
- Piston ring worn, broken, or stuck
- Piston seizure, damage
- Cylinder head gasket leaking
- Exhaust pipe leaking at cylinder head connection
- Crankshaft runout excessive
- Engine mounts loose
- Crankshaft bearing worn
- Camshaft chain tensioner trouble
- Camshaft chain, sprocket, guides worn
- Balancer bearing worn
- Balancer gear worn or shipped
- Loose alternator rotor

Abnormal Drive Train Noise:

Converter noise:

- Belt worn
- Drive or driven pulley sheave worn
- Drive or driven pulley movable sheave bush worn
- Drive or driven pulley mount loose
- Driven pulley shoe worn
- Drive pulley weight or roller side washer worn
- Drive pulley weight or roller worn
- Wear guides worn

Transmission noise:

- Bearing worn
- Transmission gears worn or chipped
- Metal chips jammed in gear teeth
- Engine oil insufficient or too thin

Front or rear final gear case noise:

- Insufficient lubricant
- Incorrect oil (Front final gear case)
- Bevel gear bearings worn
- Bevel gears worn or chipped
- Bevel gears maladjusted
- Worn LSD clutch friction plate (Front final gear case)
- Worn LSD clutch spring (Front final gear case)
- Damaged side gears or pinions (Front final gear case)

Abnormal Frame Noise:

Shock absorber noise:

- Shock absorber damaged

Disc brake noise:

- Pad installed incorrectly
- Pad surface glazed
- Disc warped

Caliper trouble

Rear brake noise:

- Foreign matter in hub
- Brake not properly adjusted

Other noise:

- Bracket, nut bolt, etc. not properly mounted or tightened

Exhaust Smokes Excessively:

White smoke:

- Piston oil ring worn
- Cylinder worn
- Valve oil seal damaged
- Valve guide worn
- Cylinder head gasket damaged
- Engine oil level too high

Black Smoke:

- Air cleaner clogged
- Main jet too large or fallen off
- Starter plunger stuck open
- Fuel level too high

Brown smoke:

- Main jet too small
- Fuel level too low
- Air cleaner duct loose
- Air cleaner poorly sealed or missing

Handling and/or Stability Unsatisfactory

Handlebar hard to turn:

- Tire air pressure too low
- Steering stem bearing damaged
- Steering stem bearing lubrication inadequate
- Steering stem bent
- Damaged steering knuckle joint
- Damage tie-rod end
- LSD clutch maladjusted (front final gear case)

Noise when turning:

- Damaged side gear or pinion (front final gear case)
- Worn LSD clutch friction plates (Front final gear case)
- Worn LSD clutch spring (Front final gear case)

Handlebar shakes or excessively vibrates:

- Tire worn
- Wheel rim warped
- Rear axle runout excessive
- Wheel bearing worn
- Handlebar clamp loose
- Steering stem clamp bolt loose

Handlebar pulls to one side:

- Frame bent
- Wheel maladjustment
- Suspension arm bent or twisted
- Steering stem bent
- Front or rear tire air pressure unbalanced
- Front shock absorber unbalanced

Shock absorption unsatisfactory:

Too hard:

- Tire air pressure too high
- Shock absorber maladjusted

Too soft:

- Shock absorber oil leaking
- Shock absorber spring weak
- Tire air pressure too low
- Shock absorber maladjusted

Troubleshooting Guide

Brake Doesn't Hold**Front brake:**

- Air in the brake line
- Brake fluid leakage
- Brake fluid deteriorated
- Primary or secondary cup trouble
- Master cylinder scratched inside
- Pad overworn or worn unevenly
- Oil, grease on pads and disc
- Disc worn or warped
- Brake overheated

Rear Brake:

- Brake not properly adjusted
- Plates worn
- Brake parts worn or damaged

K-EBC and Selectable 2WD/4WD System Malfunction:

- Actuators failed
- Speed sensor short or open
- Forward/Reverse detecting sensor short or open
- Actuator controller failed
- Controller 10A fuse blown
- Battery disconnected

Battery Discharged:

- Battery faulty (e.g., plates sulphated, shorted through sedimentation, electrolyte level too low)
- Battery leads making poor contact
- Load excessive (e.g., bulb of excessive wattage)
- Ignition switch trouble
- Regulator/rectifier trouble
- Alternator trouble
- Wiring faulty

Battery Overcharged:

- Regulator/rectifier trouble
- Battery trouble

17-6 APPENDIX

Cable, Wire, and Hose Routing

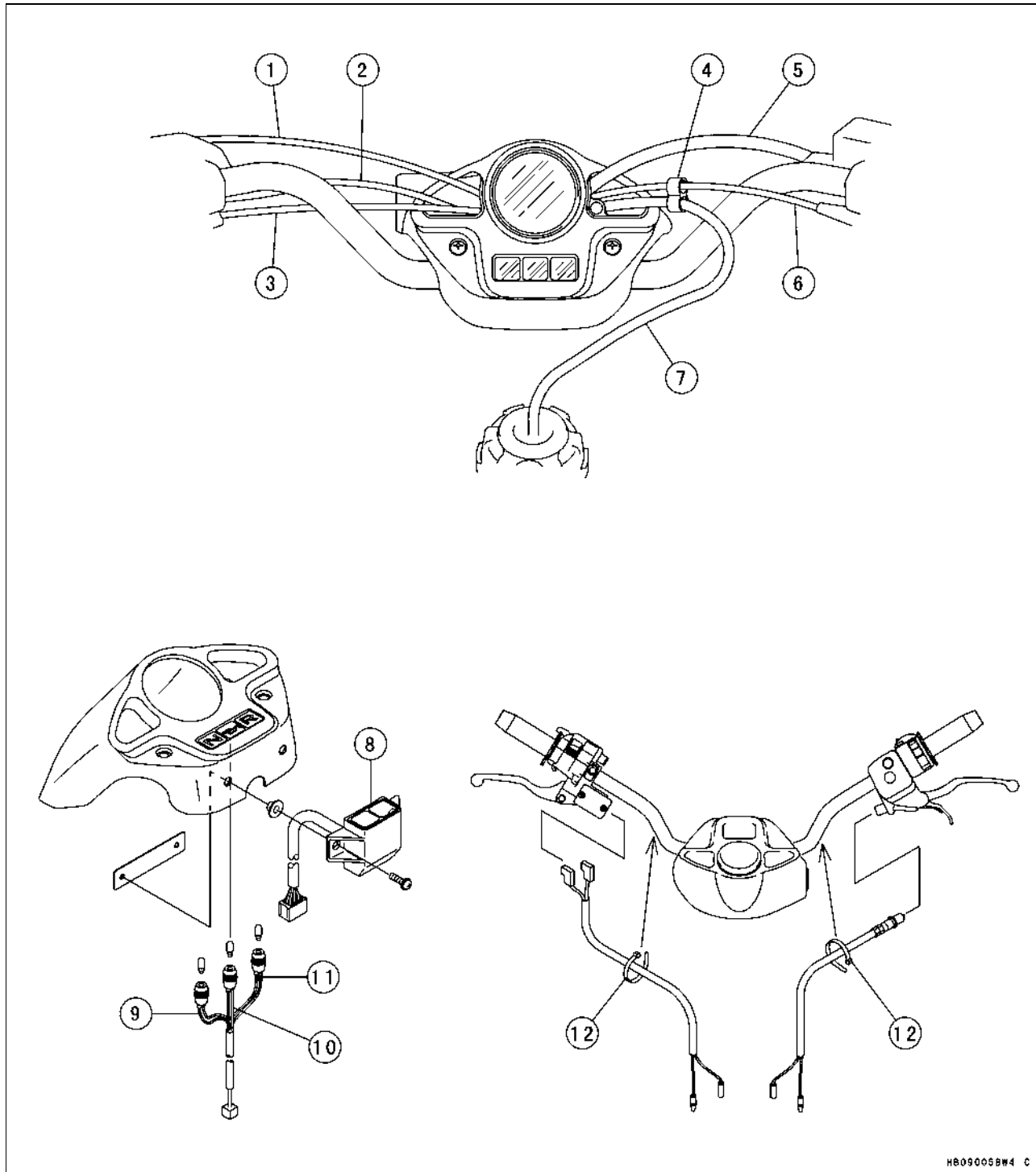

H809005B#4 C

1. Brake Cable
2. Left Switch Housing
3. Choke Cable
4. Clamp
5. Brake Hose
6. Throttle Cable
7. Fuel Tank Vent Hose

8. LED Indicator
9. Neutral Indicator Light Lead (LG, BR)
10. Oil Pressure/Temperature Warning Indicator Light Lead (W/G, BR)
11. Reverse Indicator Light Lead (R/W, BR)
12. Band

Cable, Wire, and Hose Routing

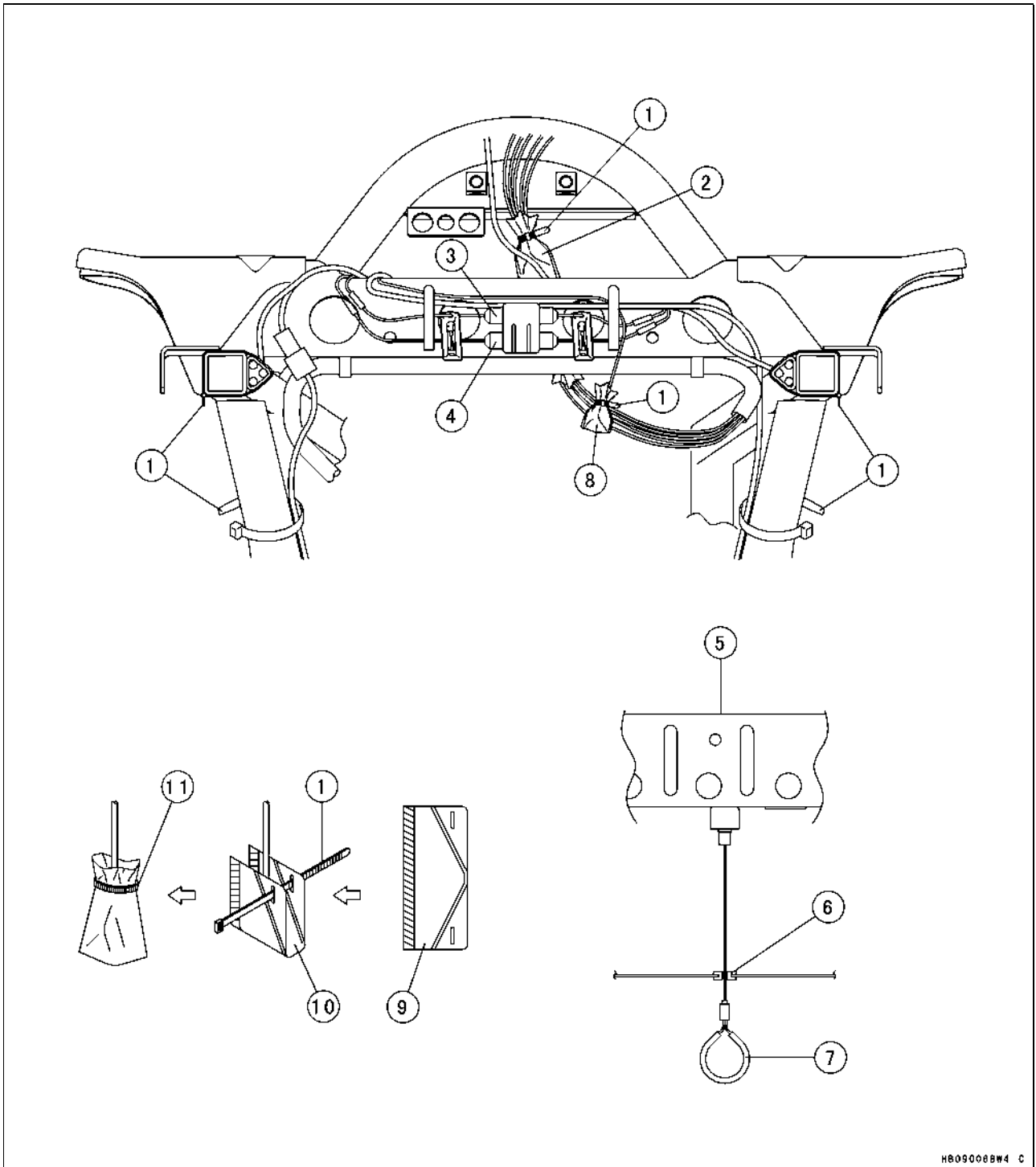

HB09008BW4 C

- 1. Band
- 2. Cover
- 3. Drive Belt Failure Detecting Switch Fuse 5 A
- 4. Oil Cooler Fan Fuse 20 A
- 5. Seat Bracket
- 6. Grommet

- 7. Seat Latch
- 8. Cover (for U.S.A. model, Speedometer Leads)
- 9. Cover
- 10. Fold the cover.
- 11. Tie the cover with band.

17-8 APPENDIX

Cable, Wire, and Hose Routing

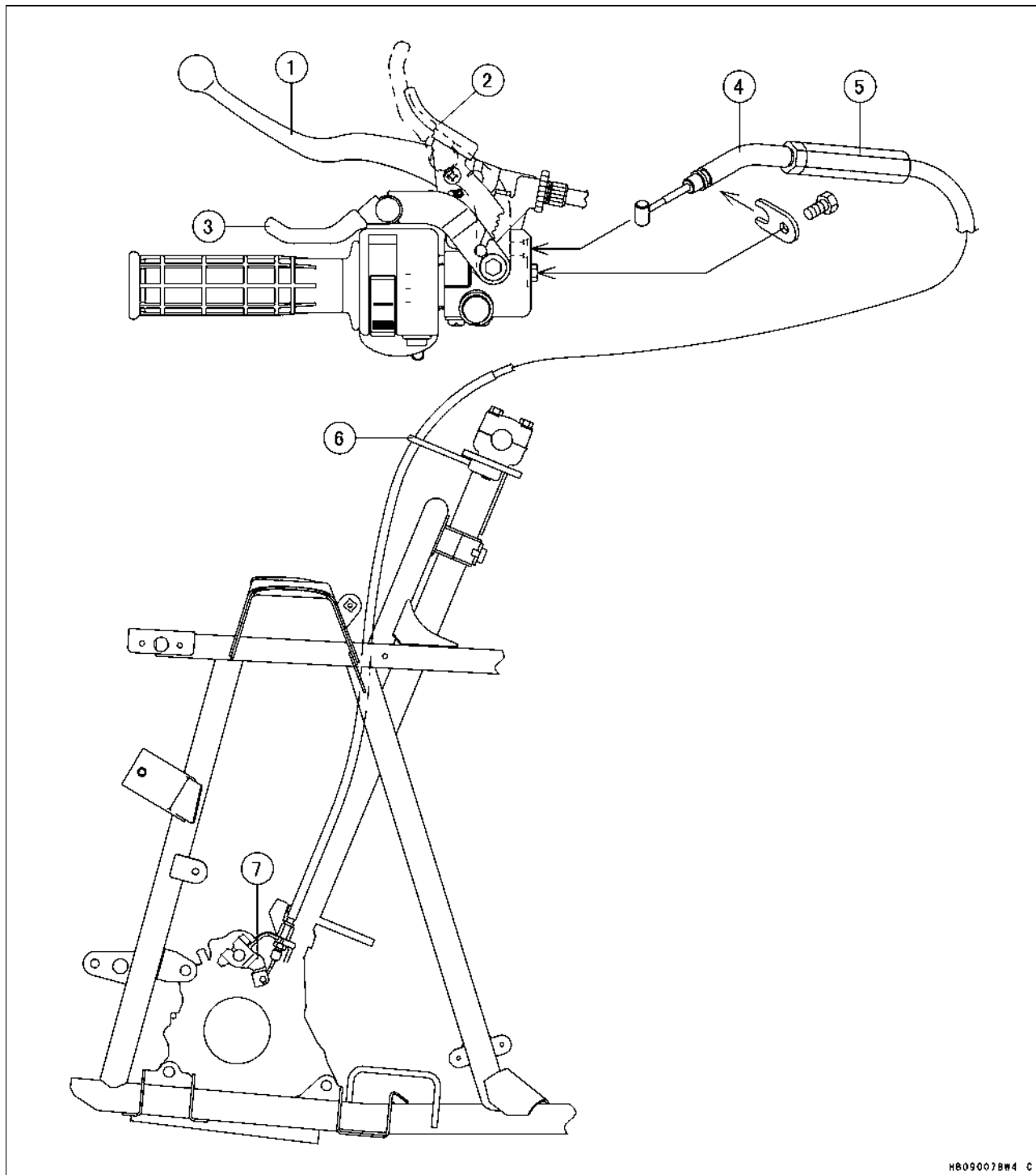

H8090078W4 C

1. Rear Brake Lever
2. Parking Brake Lock Lever
3. Variable Differential Control Lever
4. Variable Differential Control Cable

5. Cable Adjuster
6. Handle Holder Clamp
7. Variable Differential Operating Lever

Cable, Wire, and Hose Routing

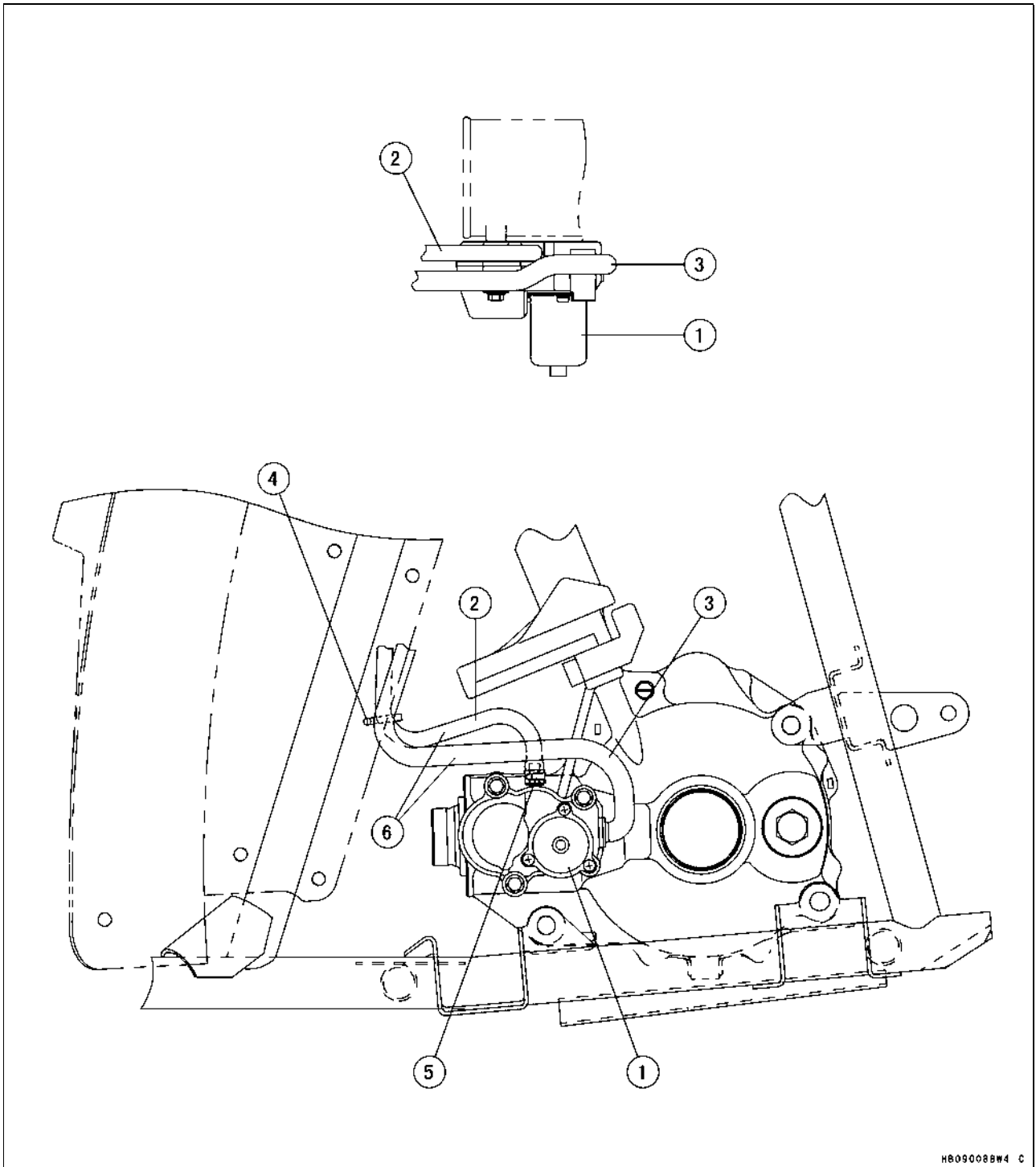

HB09008BW4 C

- 1. 2WD/4WD Actuator
- 2. 2WD/4WD Actuator Breather Tube
- 3. 2WD/4WD Actuator Lead
- 4. Band

- 5. Clamp
- 6. Do not interfere the actuator lead and tube with tie-rod etc..

17-10 APPENDIX

Cable, Wire, and Hose Routing

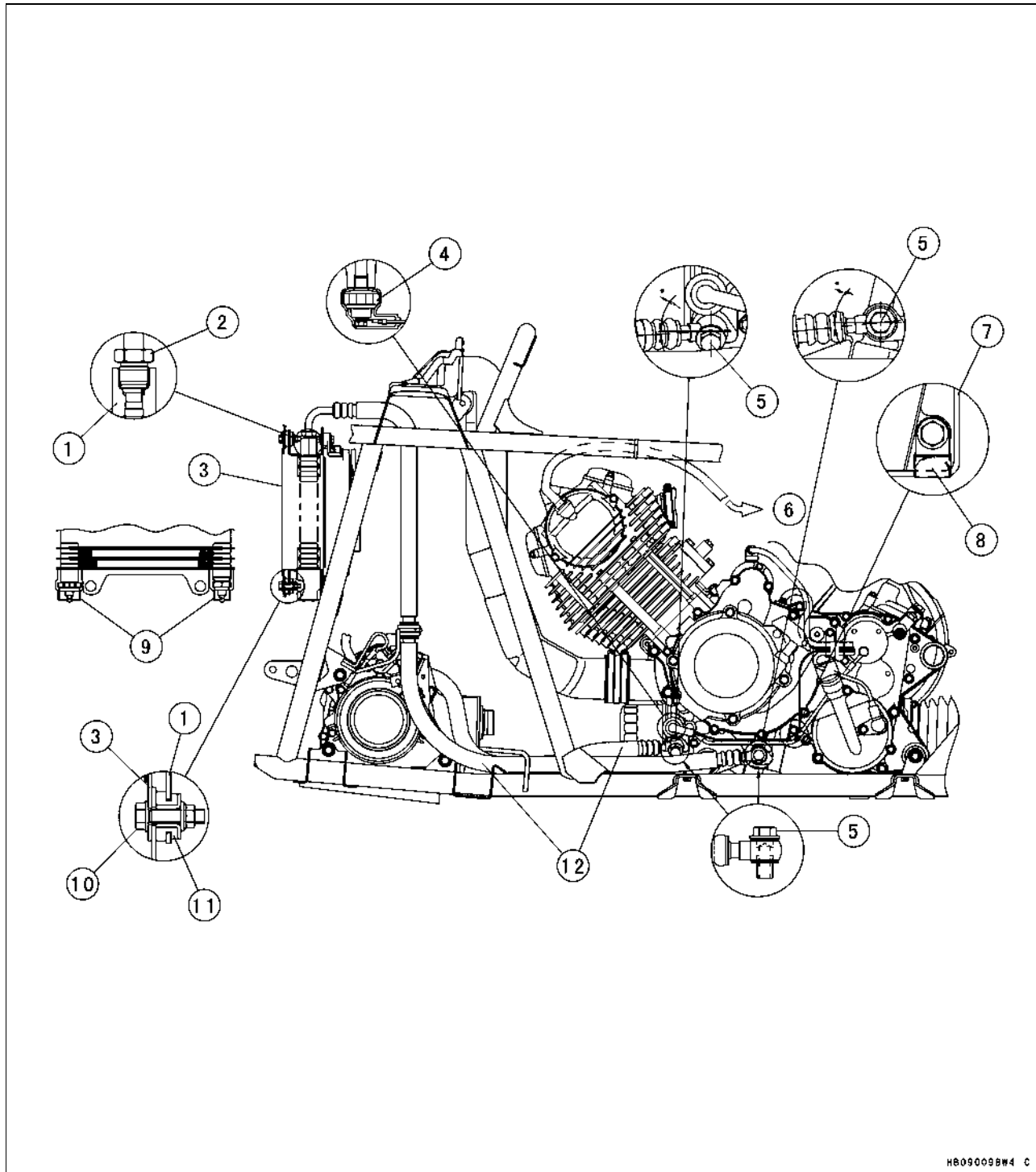

- 1. Oil Cooler
- 2. Oil Pipe Joint Nut
- 3. Oil Screen
- 4. Oil Pressure Switch
- 5. Oil Hose Banjo Bolts
- 6. to Air Cleaner

- 7. Fix oil pressure switch lead with clamp.
- 8. Clamp
- 9. Grommets
- 10. Oil Cooler Mounting Bolt
- 11. Damper
- 12. Oil Hose

Cable, Wire, and Hose Routing

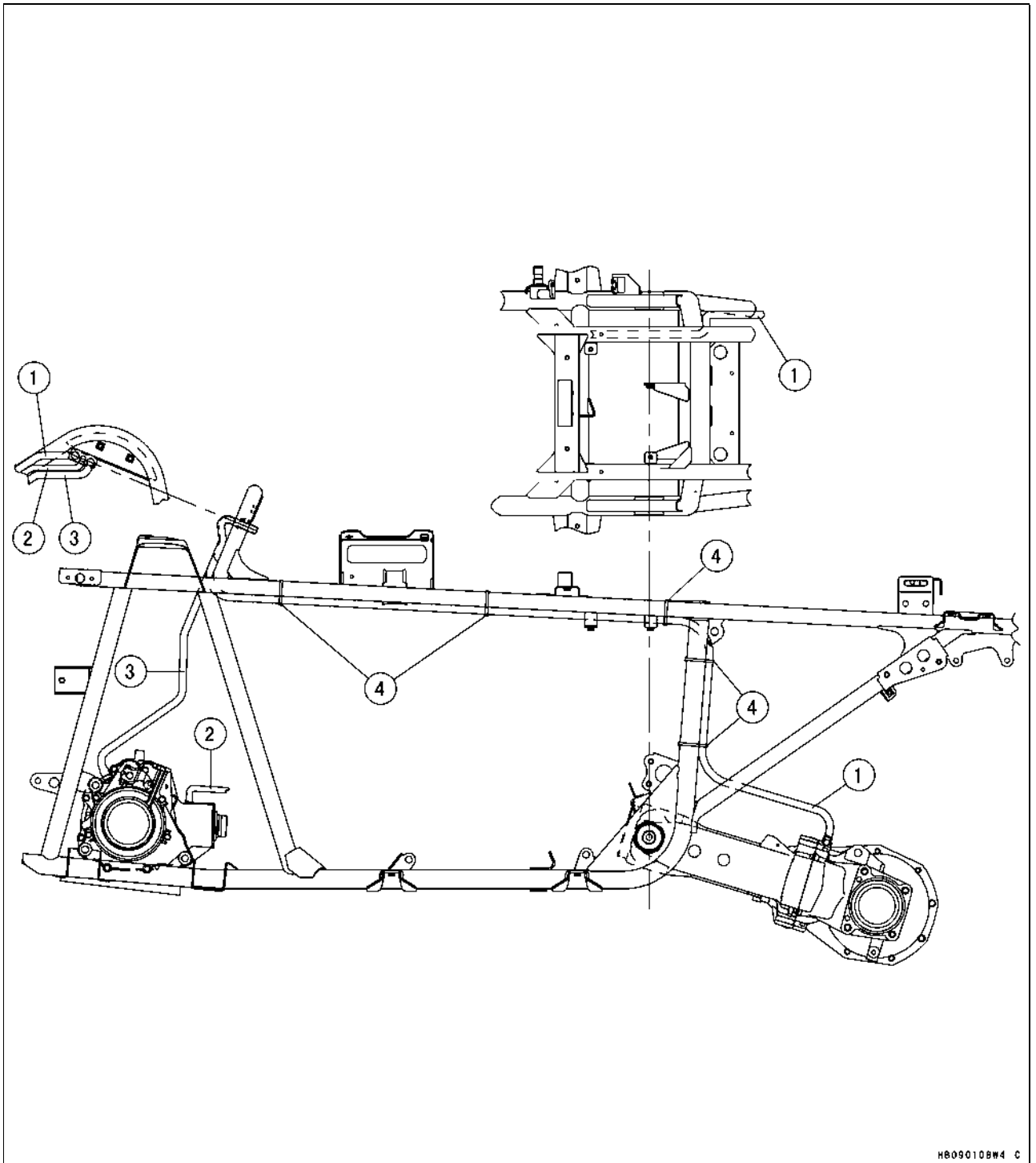

1. Rear Final Gear Case Breather Tube
2. 2WD/4WD Actuator Breather Tube
3. Front Final Gear Case Breather Tube
4. Band

17-12 APPENDIX

Cable, Wire, and Hose Routing

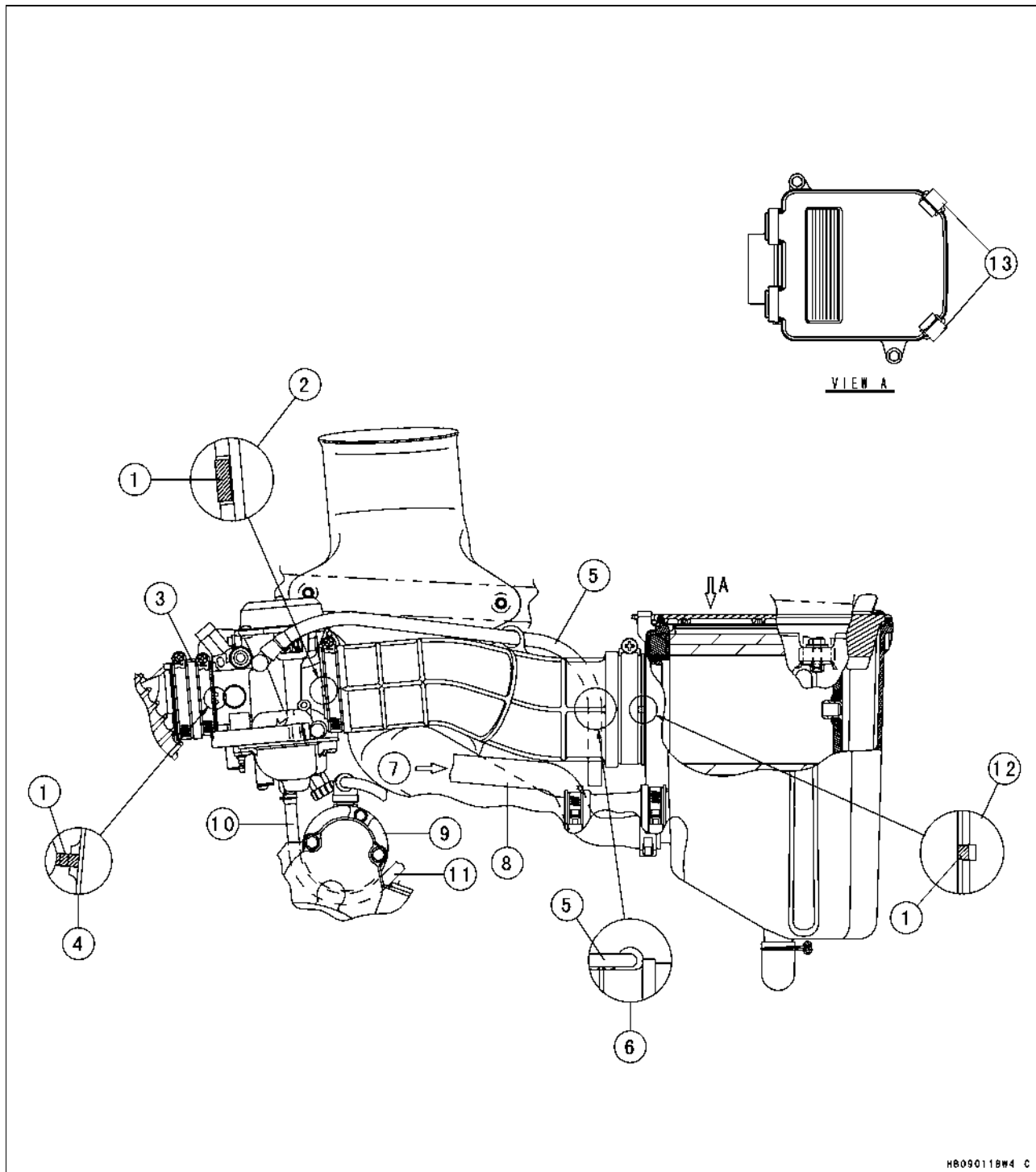

HB090118W4 C

1. Mark
2. Align the duct groove with the mark on the carburetor.
3. Carburetor Holder
4. Align the carburetor holder groove with the mark on the carburetor.
5. Carburetor Vent Tube
6. View from Upside
7. from Cylinder Head
8. Engine Breather Hose
9. Starter Motor
10. Carburetor Drain Tube
11. Run the carburetor drain tube between the crankcase and starter motor.
12. Align the duct groove with the mark on the carburetor.
13. Snaps

Cable, Wire, and Hose Routing

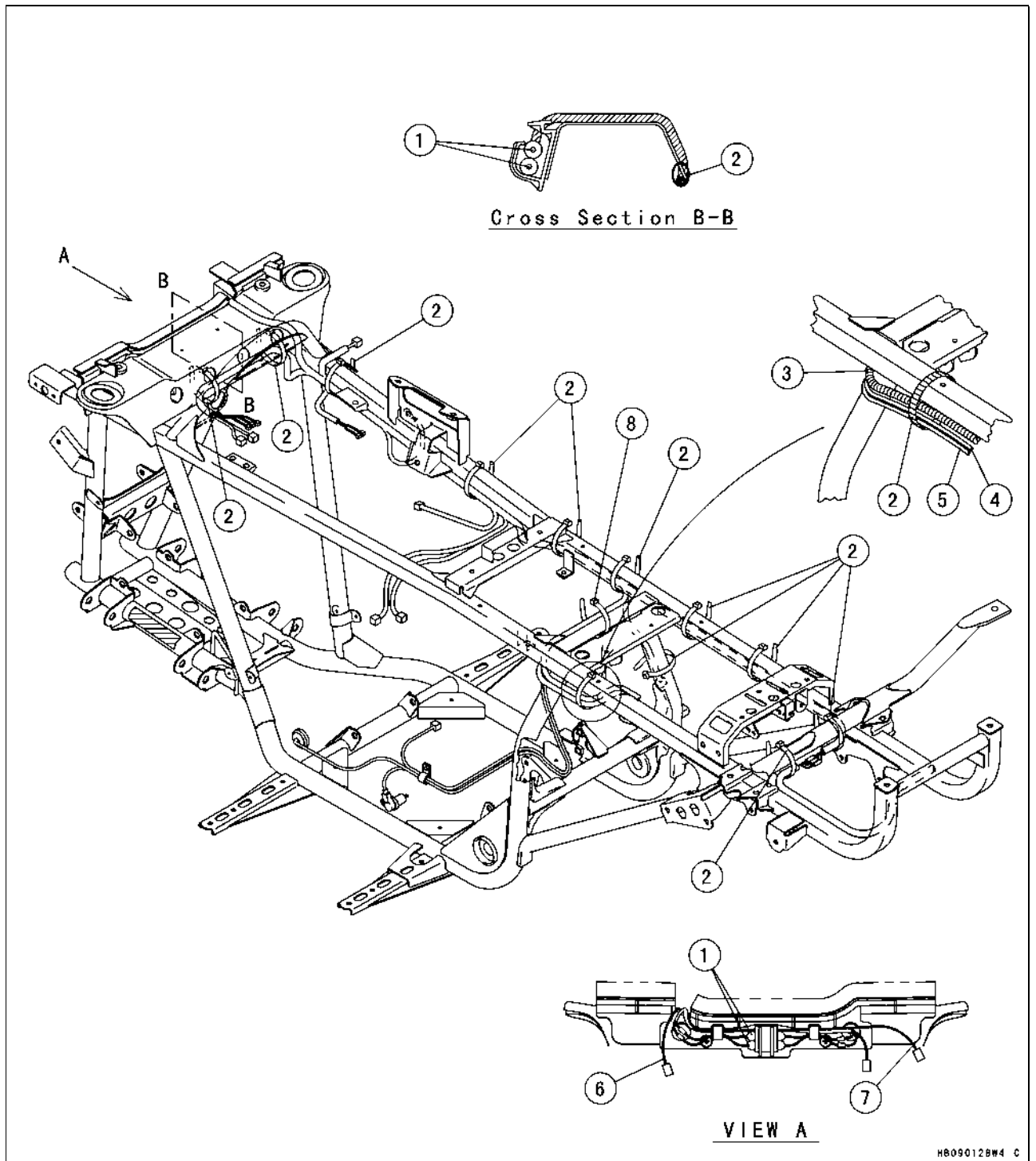

HB090128W4 C

- 1. Fuse
- 2. Band
- 3. Main Harness
- 4. Battery (+) Cable
- 5. Battery (-) Cable

- 6. Right Headlight Lead
- 7. Left Headlight Lead
- 8. Rotate head of band forward to prevent interference with rear fender.

17-14 APPENDIX

Cable, Wire, and Hose Routing

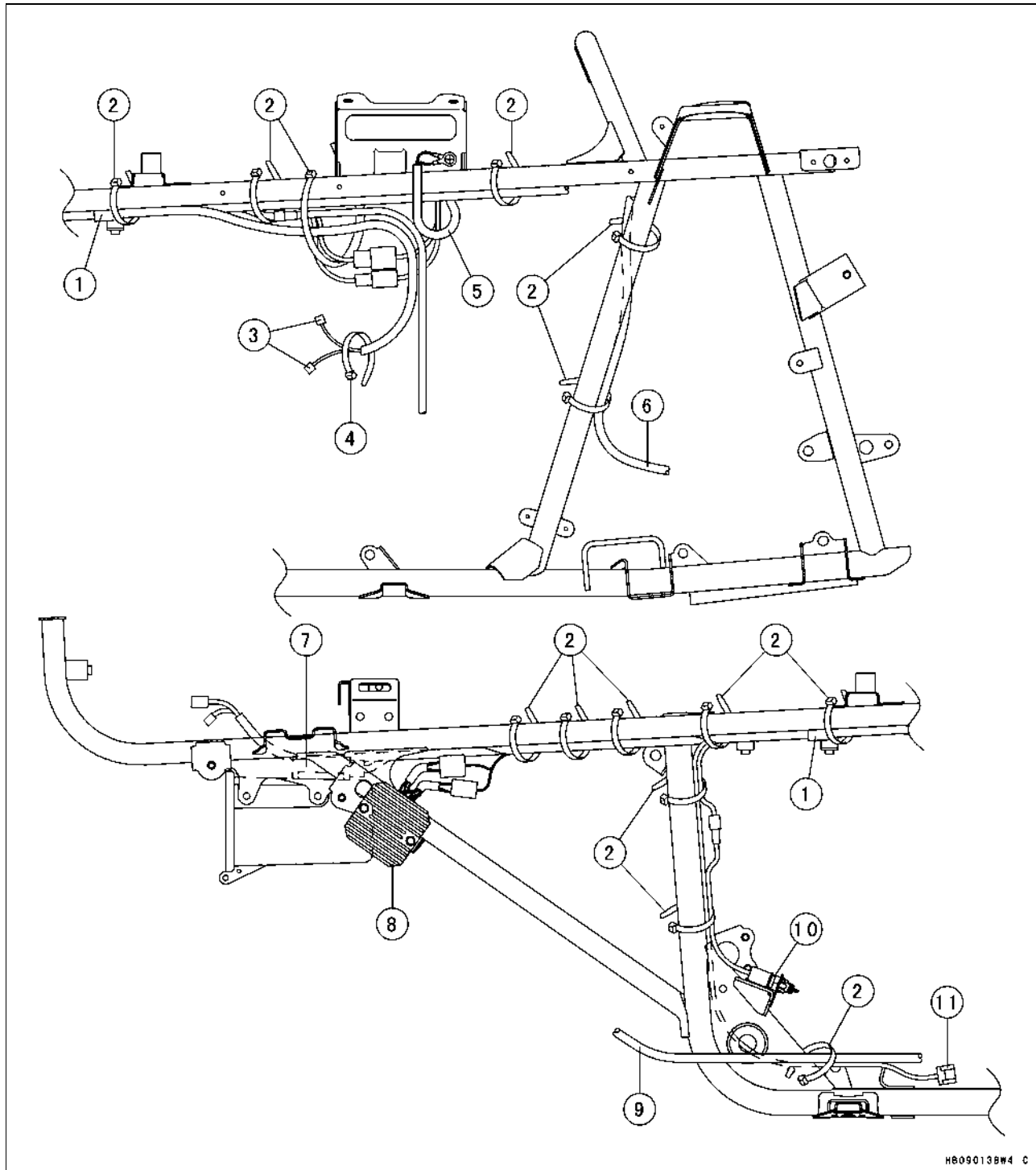

- 1. White Mark
- 2. Band
- 3. Carburetor Heater Leads
- 4. Clamp on Torque Converter Cover
- 5. Frame Ground Lead
- 6. 2WD/4WD Actuator Breather Tube

- 7. Igniter
- 8. Regulator/Rectifier
- 9. Rear Brake Cable
- 10. Brake Pedal Light Switch
- 11. Speed Sensor Connector

Cable, Wire, and Hose Routing

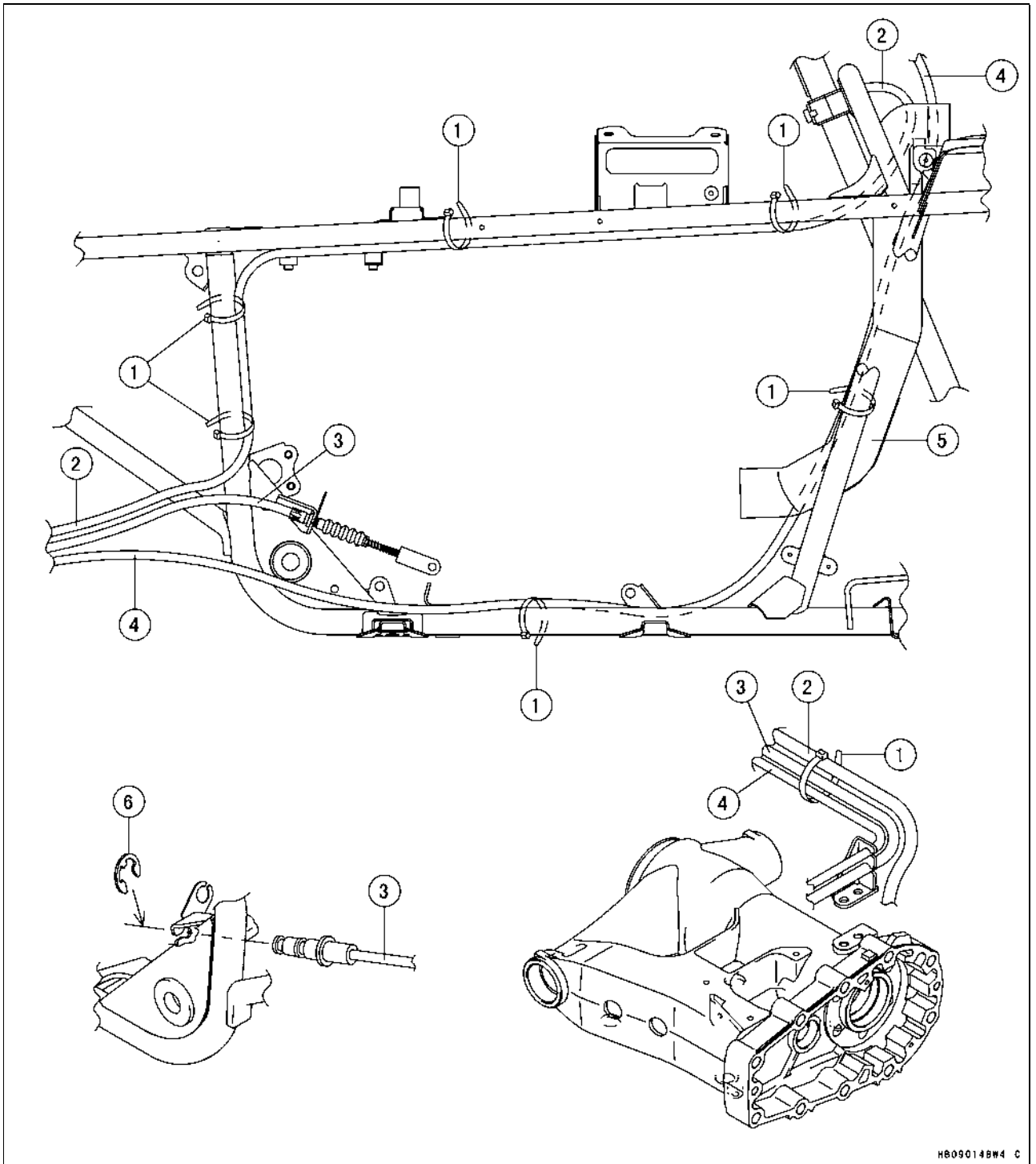

HB09014BW4 C

1. Band.
2. Rear Final Gear Case Breather Tube
3. Brake Cable (Rear)
4. Brake Cable (Parking)
5. Torque Converter Cover Intake Duct
6. Circlip

17-16 APPENDIX

Cable, Wire, and Hose Routing

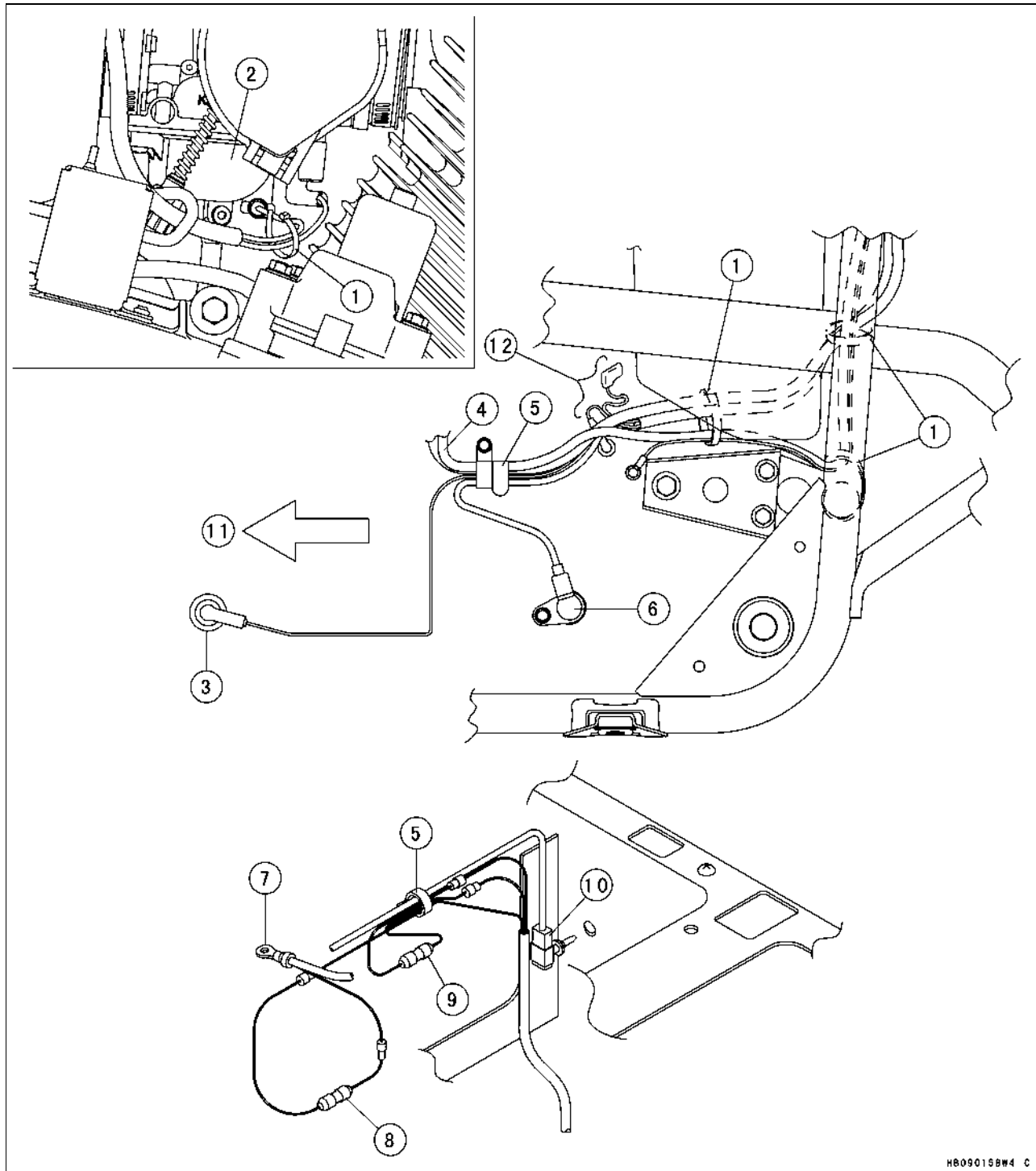

H8090159W4 C

1. Band
2. Carburetor
3. Oil Pressure Switch
4. to Starter Motor
5. Clamp
6. Forward/Reverse Detecting Sensor
7. Batter (+) Terminal

8. Main Fuse 30 A
9. Accessory Fuse 5 A
10. Air Temperature Sensor
11. Front Side
12. Apply grease (Amoco rykon premium grease No. 2 EP Green) to terminals of neutral and reverse position switch.

Cable, Wire, and Hose Routing

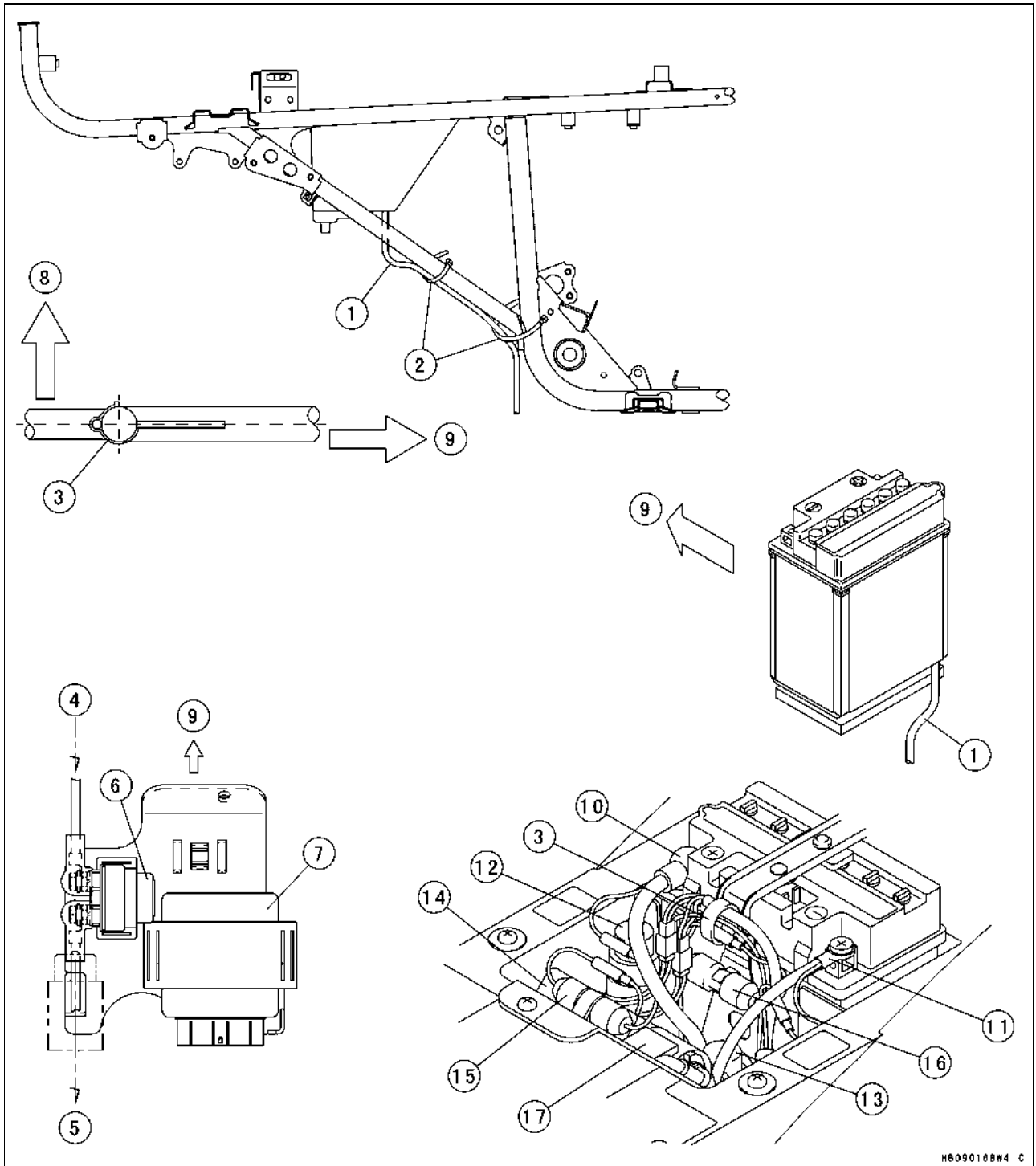

HB090188W4 C

- 1. Battery Vent Hose
- 2. Band
- 3. Clamp
- 4. Starter Motor
- 5. Battery
- 6. Starter Relay
- 7. Actuator Controller
- 8. Inside
- 9. Front Side

- 10. Battery (+) Cable
- 11. Battery (-) Cable
- 12. Starter Circuit Relay (Brake)
- 13. Starter Circuit Relay (Neutral)
- 14. Actuator Controller
- 15. Main Fuse 30 A
- 16. Accessory Fuse 5 A
- 17. Starter Relay

17-18 APPENDIX

Cable, Wire, and Hose Routing

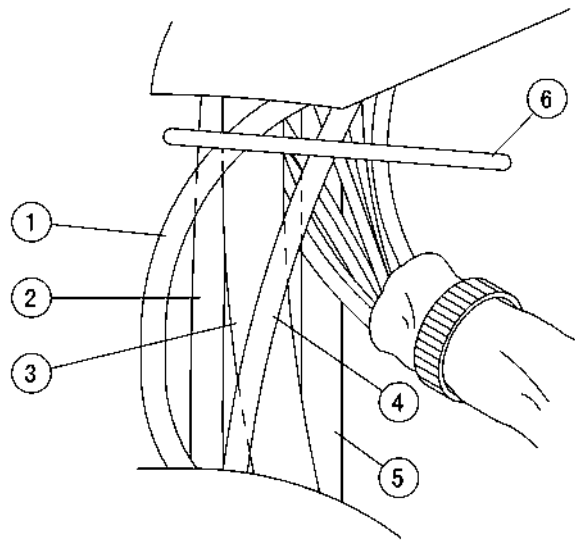

H8090178W4 C

1. Variable Differential Control Cable
2. Throttle Cable
3. Front Brake Hose
4. Choke Cable
5. Rear (Parking) Brake Cable
6. Clamp