

F. Shkrudnev

N. Levashov's
«SvetL Broom»
in A. Khatybov's
«Bath School»

Book 1. Unmasking the Hidden

Life goes on...



Feodor Shkrudnev

Life goes on...

**N. Levashov's «SvetL Broom» in
A. Khatybov's «Bath School» and
A Labour Spade**

**The continuation of the third volume of the
monograph «The Mirror of My Soul» not
completed by Nicolai Levashov**

**BOOK 1. Unmasking the Hidden
(intervention: how it happened)**

Translated from Russian by Alla Khabenskaya

Saint-Petersburg 2017

Foreword

The modern system of man's views once firmly settled and for quite a number of hundred years being polished is clearly reflected in the scientific way of looking at things. They are well-grounded, fundamental, and steadfast in the truth of their position – In a word – "**SCIENCE**". It's like **something that is unattainable for anyone and everyone**. It is not like some intricate craft, which, although being difficult at times, can be mastered by anyone to some extent, and therefore, it is quite real to get the title of master. Science is the lot of quite a few. It is necessary not only to have weighty intellectual resources, moreover, extended in some area to unconceivable dimensions, making it possible for you to judge things more confidently than anyone else. You also have to be scientifically minded so that you are able to save your face in a worthy manner in the circle of your kind. Well, and if you make some effort – it will give you the opportunity from the considerable height of your highly scientific intellectual statements to judge about the possibilities and achievements of both less experienced and eminent 'bison' scientists, fatherly suggesting a way to a new essential scientific research so far being noticed by no one. Scientific activities that are so much desirable and hardly ever easily attainable and only to a few worthy ones turn out to be very close, but for the majority it proves to be a true revelation at the beginning – what an ample scope to creative work!

How much of under-explored and under-investigated has the modern scientific school offered! How much good could one do to it with one's work! Experienced scientists in a majority take young scientists in their ranks with such tangible kindness and care suggesting and directing them in so hard, but fascinating scientific search. Although somewhat has been modified in the political and economic battles, the scientific school has still preserved for the true scientists the opportunities for their development in the form of grants, which are distributed according to the most promising trends for the development of science in general and its application in the national economy. It is true, there are some discrepancies, temporary or local difficulties, but they are only bumps on the way of formation and development of Science presenting itself as a kind of a monster, created with only one aim – to lead the humanity away from even the possibility of

perception the real picture of the world, having created and imposed upon everyone a false world outlook based on invented myths, and having provided these inventors with a halo of indisputability and inaccessibility in their scientific greatness – that is for the layman; and inside this hard-to-reach scientific community – to organize exactly the same parasitic conditions, as outside it.

Every ordinary scientific worker of a higher educational institution, research institute or any other organization that is a part of the Scientific System can not fail to see all of its unstable, but for some reason still being supported structure. Each of its participants comes across it and tries to exist somehow, or even to prosper, but in everyday hustle and bustle not all realize what each of them is part of. The problems of survival are not complicated and make you to be in a whirl – publications, scientific studies, dissertations, author’s abstracts, Higher Certification Committee, citation indexes, scientific projects, reports, check ups, titles and degrees – all these attributes of the scientific life got together are a simple and effective tool to manipulate a person, even if he is really intellectually developed and has an extraordinary mind. It is trivial, isn’t it – but for something more than “drawing up”, there is simply not enough time, energy, or desire. Alas, but Science, on the one hand, is a well- thought out and well-made trap for capable, purposeful and intelligent people, besides, aiming at not giving a chance for real development to anyone. And on the other hand, it is a cushy job in which, providing you have certain qualities of thinking, you can live your life without exerting yourself too much with comfort and pleasure relying on lower-ranking scientists and on legal grounds to use the results of their work (the concept ‘a wedding general ’ is a common expression with them). In the community of research workers everything turns out to be meaningless in the most basic sense of the word. If you are interested in doing research in many fields simultaneously, you will easily be convinced that this is futile and you will be turned into a narrow specialist who knows in detail the number of mandibles in some arthropods, but you will never think of the fact why your favorite, fostered and personally described subspecies bearing your name, and including 19 differing in the number of denticles and having the shape of the bristle morphs, generally exists on the Earth, and why it exists in these 19 morphs. If you examined the work of the supervisor and fundamentally disagree with his point of view **you will have to say goodbye to the defense of the thesis**; an eternal title of an assistant and, in most cases, quite a trial in search of a new scientific leader – that is your destiny for many years. Suppose you go your own way and

thanks to your intelligence, talent and diligence are able to maintain your opinion and even to defend your thesis. That is perfect. But this is the end. Be happy with your degree, so much wished for, your salary and general admiration. You are a part of the system and there is no way out.

I apologize to a reader for such a lengthy introduction, but I thought it is necessary to some extent **to throw light upon the present day science from my point of view.**

We certainly enthusiastically study and investigate with sincere interest behavior of gophers, imitones in nightingales' singing, nutrition of musk deer, finding some pleasure and satisfaction in it, and creating some imitation of some usefulness to the society. But all this is a complete nonsense and utter rubbish. Believe me, most of the work is done under certain requirements to get some "bonus" in the form of money, titles (meaning money), some articles (meaning, titles and then money), grants (again meaning money), and for a change – for some ambition. Everything, as in any other field, rests on getting some material goods. It is quite different in case of already received benefits or available initially. Or – if the Person is engaged in something far from what is called science. **For example, if he is "Dilettante in science..."**

Any view on the surrounding reality without any bias is a challenge, it is a blow to the Brain, and it is an attempt to get it out of the state of sustainability. On the one hand when there is a person who is offered all kinds of opportunities: he is told how this or that works, he is given facts, he is persuaded and praised when he accepts the proposal. For the person who once adopted a certain point of view it is very difficult to change it. For this there must be some itch to it, some patience, firmness of purpose, and some stimulus, which will help to leave the comfortable perch and look around. Then a person might see some fragment of reality and realize that his Science teachers are wrong. He will never come back, and might choose some others. But on the other hand – when the Science teacher must be taken out of the stability, that is that source of "true" world outlook, **who knows** what is right and what is wrong, **the one** who imposes one's prejudice on everyone, and who, in fact, has been created and nurtured by the system. It amounts to a refusal to ride in a comfortable car, moving on a flat road to a bright future, heading a column of vehicles and pedestrians, or to go on foot to the mountains, where rapid river streams knock you down, and where falling pieces of rock from the slopes fall down on your head, and the danger of loosing your footing deprives you of your mind; and the strangeness of the

surroundings makes it impossible to take a breath. No one will accept it on one's own free will – the road is hard, there is no pleasure to move on it, and the most important is that situation that there is no reason to start on a journey. The choice of any reasonable person in this situation is obvious, and it leads to nowhere – after all, - that abandoned comfortable modern car moving on a flat, well-paved road, which after two turns comes abruptly to an end and then – just nothing.

But by some strange coincidence, which is probably going to be realized some day and translated into the plane of human perception – **suddenly there appears someone's hand**, opens the doors of the comfortable cars, ruthlessly pulls the passengers out and kicks them out of the habitual reality onto the mountain path. That is all, nowhere to go – you can sit on the rock and indulge in dreams about the old times, remember changing your Zhiguli for Toyota, with much less damages, but that very moment you open your eyes and everything around you looks uncomfortable, unfamiliar, strange, original and majestic in size.

Again I apologize to the readers for such a "non-scientific" comparison, but there are reasons for that. The phenomenon that a man comes across for the first time **after realizing the falseness of the world outlook presented by science and near-science** is impossible to denote by the usual figures of speech, but sooner or later, this emotional component passes, giving place to the observations, reflections and conclusions.

To have a look at the world in a new way, to see things previously unnoticed, to perceive the magnitude of the delusions, and to proceed working your will but not imposed by someone – **all this becomes possible with the Information**. Of course, it is easier to believe someone or something and, once having been defined, take your own position, defending its implacable justice, and loyalty. It gives you some sense of confidence and self-sufficiency up to the time, when new facts and the information having got from the outside will negate all earlier applied efforts. **Therefore, the most valuable and urgent, that facilitates the development, is Information, besides being reliable, but not planted on or fabricated**. It is all around us, but we must learn to see it and make the right conclusions. And it is not taught in any academic publications. However true and methodically correctly the textbook might be – whether it is written for philosophers or biologists, even with the most careful study, it will not teach you, because it has been created, like any other

recognized scientific or popular publication, in the framework of the System, and thus, strictly keeping to its mission to maintain a person's world view within the given framework, developing (or rather changing) in the permitted directions and create the illusion of some scientific progress.

Today's abundance of books of the works of different authors with the help of the World Wide Web, and not only, has been turned into the ocean of debris in which to find the needed is extremely difficult. After all, when looking for something everyone is guided by something prepared that will give one everything at once, besides, it should be comfortable and pleasant – in short, that "something" should duplicate that smooth way in a comfortable car, but it might be to the other side and with some other views along the way. **For this reason, all the books that really give a MAN an opportunity to develop oneself, and open the locked door a little bring about some rebuff, rejection, but at the same time attract people, make them criticize, indignant with the content, pull out some facts, that make a riot in the heads or, on the contrary, create euphoria.** All this is not very important in general; it is just a quest process, which, especially in the tense moments may cause outrageous emotions of various colors, and a sharp change in one's general state and twists and turns of fate. It is important that this break-up leads to the perception of the reality, although it affects everyone's imagination – both – in what way and why the Humanity has been formed and what awaits it in the future.

Of course, the authors of these books leave the reader with absolutely unbearable interest. It is an exorbitant phenomenon by the standards of any human being, and the more successful the reader is in the area of his application (for example, a successful scientist or a prominent politician), the greater his reaction might be, regardless of its color. This is a natural manifestation of reading books by such authors, who, without proving some higher Truth, just provide Information in the broadest sense of the word, and demonstrate the possibility to come to a reasonable and fair conclusion on the basis of its profound analysis. Such books are never published under the imprint of the Academy of Sciences, they do not get an overnight universal recognition and understanding, and their authors never strive for something of this kind. But their readers get something that **every true human being is eager to get – perception of the reality through the comprehension of the information** that everyone can learn to obtain in an authentic form, without distortion or imposed false views, convenient to

anyone. **N. V. Levashov, A. M. Khatybov, N.A. Morozov, B.V. Makov** are the authors of the books that can give everyone all this.

Feodor Dmitrievich Shkrudnev is the Man who will make you do it without giving you the chance to return and plunge into the swamp of the usual stereotypes, and again get back in your comfortable car speeding along a straight road to the cliff.

The Book created by Feodor Shkrudnev I have had a chance to become familiar with and which is now in your hands is, in the first instance, **A Challenge**, –a challenge both to everyone and to the System. While reading it your Brain is being in the state of non-stop intensive work. Everything in it causes some mental rebellion, makes you set out in some quest and pull you out of the quagmire of the habitual judgments. Everything **in It is “quite different’ from the expected.** Whatever you touch upon is going to be “wrong», not the way it is accepted, different from what you might expect from THE BOOK.

F. Shkrudnev’s work with quite a strange name – N. Levashov’s "SvetL Broom" in A. Khatybov’s "Bath School", which is marked by the author as the sequel of the third volume of "The Mirror of My Soul" by N. Levashov is more than a continuation of his autobiography. Certainly, to a number of points concerning the biography of N. Levashov is given some attention. But neither more nor less. They are not even digressions into the biography of N. Levashov to satisfy the curiosity of the reader. It is a description of certain factors that enable you to make a more complete judgment on things and objects that are more important than the personal life of the Outstanding Russian Scientist. It is more important to get to know some things about physics of the process of generation, about which little is said in A. Khatybov’s works and which some people have already got acquainted with firsthand while using "SvetL" Technology, than about the details of Nicholai Levashov’s family life and his attitude towards these or those people. It cannot be any other reasonable judgment on the question of what should be the whole book about; Everything that was necessary to put on paper about his life, N. Levashov did himself to forestall all possible strife in this matter: "I thought that if someone is interested in my life and my path no one but myself would be able to tell you what and when had happened in my life, what I had thought in certain situations and what I had felt and experienced... And as long as this is my life no one but me will do it better..."

Being aware of this, as well as having clear perception of what is indispensable to a human being for knowledge, and where just some banal

curiosity begins, determined the contents of the books by Feodor Shkrudnev. It could not be otherwise. But his chosen path and the style of presentation are limited from different sides – the publicity of the information presented is restrained with absolutely non-public details and fundamental discoveries. As far as generation is concerned the author has said a lot without saying anything that could give the appearance of knowledge. For biologists it will be important to read and learn about the real structure of a living cell, known to them from traditional scientific publications, but they will have to make sure, that scientific journals and their authors do not have the slightest idea either about the structure of a living cell, or about its capabilities. What you really get from reading the Book but what cannot touch is the information and an impressive push (as they say – "kick") to thinking it over.

The style of the text probably seems to be structured in a somewhat unusual logic. You may not find either some common logic or simplicity of exposition in this Book in that form which is accepted for the reputable and claiming to be fundamental publications. Everything is quite different here, and is likely to be similar to the DNA helix in that form in which it first appeared in the thoughts of its first observers. The most complicated design, with numerous interconnected and interdependent, **strictly verified and conceived by someone**, but at first glance, looking like a very incredible and intricate tangle of «don't know what". When you begin to look into, following the windings of the stated events and facts, you see strict helical structure, which invariably brings you back to the previously mentioned facts, making you see their connection with the others, and appreciate their place in the overall design much deeper. On the following turn the same, already "familiar" facts seem to be mentioned not quite casually, **but having their specific place** that is defined not by coincidence, but by previously unnoticed and misunderstood regularities. This kind of perception makes you reorganize the whole construction created in your head after reading – it is getting more complicated, acquiring some rigorous simplicity and significance.

I think any person related to some scientific activities in the modern sense of the word, cannot ignore the issue of involvement to the proceedings (both yours and others') literary sources. Indeed, with this we are all very strict – plagiarism is punishable and to rely on the works of predecessors is imperative. Failure to follow these scientific morals is fraught with very unpleasant consequences. There is no problem to find the sources of all mentioned, to keep to strict adherence to the authorship, to nurture your

own works, and to observe accuracy in the references to the works of colleagues and teachers. It is necessary to clearly track of what is whose, to avoid confusion, when all "this" is going to be transferred into tangible assets. The chain is not intricate – who came up with the idea, developed it, got under it (you need to substitute – the Department, a grant, place, job, an entire institution, rank, degree, position, honor, monograph, recognition, etc.) – that one is the owner, and no one should forget it – the ability to convert it into profits, as well as amuse your self-esteem and support absolutely essential in the scientific community ambitions must be maintained in the operable condition. The converse is also true – should you have published something obscene – that is something that brings about such a sober and fresh look at the existing ideas making the whole pyramid topple over – then references to this ugly creature mark an outcast, a renegade in his frenzy being carried too far – someone might say with a sigh, " Well, he did give some hope!.."

However, those works that are created with another purpose, those ideas that are born not in the frame of the old System, something that breaks down the Foundation, clearing up the place for the substantial construction of the mind in the direction of finding the truth, **do not even include such a notion as plagiarism.** Therefore, those for whom the very essence of this phenomenon is something Sacred may not move further as all most sacred shall be ruthlessly destroyed as not wanted. That is "the BROOM" for – to slash vigorously up to scratches on the "body", and the anguished cries of plagiarism just will not be understood or heard – the "**Bath School**" is too far from modern science and its postulates. Well, as far as the text of the Book is concerned – just try to ask such a question: How can you make the reader conceive what the Book say about otherwise? It is a rhetorical question – no matter the way you try but for the author to get the intended the only possible way is to involve what was said by one Man and what was written in this respect on another level of understanding by another Man, and what the third Man added to all this without decorating with so favorite references – and to present it to the reader as a single continuous whole in all its infinite capacity and the development of thought. And if the reader sees the point the desire to break the book with some acknowledgment does not appear – it will do such work in your head, that your own suffering Brain will begin to generate for itself quite unexpected things.

But to calm the requirements of morality of every reader, none of these People – the Authors of the texts, partly given in the Book, are hidden, on the contrary, their names become more significant than any record-largest

citation index after reading the Book. **But it is more than participation as an integral unit or a plurality of such units in the bibliographic list of the used literature.**

Whatever side is used to appreciate the result of Feodor Shkrudnev's Work it does not fit any accepted scientific or near-scientific standards that are being used when writing scientific or popular science books. All these, as well as any other formalized versions of various standardized approaches cannot be applied to such Work. Everything having created by the author, is beyond the existing so far and inevitably collapsing now the System realities, it teaches us to think independently, provides Information that is above any price, and makes you discard all that was imposed upon the Man with the upbringing, education and experience distorted with the false life values. Do not You think now that this Work with such a strange name for a narrow-minded person called N. Levashov's "SvetL Broom" in A. Khatybov's "Bath School" and a Labor Spade is the public beginning of the true New Science?

*Doctor of biological Sciences,
Professor V. O. Salovarov*

*To
Nicolay Levashov
Svetlana Levashova and
Tamara Shkrudneva –
Dedicated.*

Knowledge is the most important, the most beautiful and needful in human life. It has always been and will ever be the highest manifestation of the world perception. Only on the basis of his knowledge and his perception of the world around is Man able to transform Nature and himself.

Acknowledgments

Firstly (and finally, or to be more precise, at all times), I would like to thank all the Sources that are in this book; Sources of all that my Knowledge and experience are made of, on the basis of which it is being realized what is gradually becoming **PUBLIC** and is working for **THE GOOD**. I have told in detail about these sources in the book. But the main source are my meetings with Nikolai Levashov, our heart to heart talks, his works and what I **HAVE PERCEIVED** thanks to him.

Secondly, it is obvious to me that each of us can make a list of people who have influenced our lives and our **KNOWLEDGE** so meaningfully and deeply that it is **IMPOSSIBLE** either to explain or describe it; who shared their wisdom with us, told us about their truth, helped us survive all our mistakes and failures with endless patience and found only the best in us. In their acceptance, as well as **REFUSAL** to accept in us something that we would like to get rid of ourselves; these people encouraged us to grow, encouraged us to become something **GREAT**.

I would also like to include some of my Friends in this list, whose names I do not mention for confidentiality, although I aware of and appreciate their part in my life and what they have done and are doing

concerning the already **CREATED** and **BEING CREATED Technologies** and **Programs** with a common name "**SvetL**", approved by N. Levashov, about which you will get to know a lot after reading this book. I especially want to **thank B. Makov, I. Kondrakov, V. Ikhtisanov, A. Goncharov, A. Yuriev, V. Chudinov, and V. Efimov** – the people who are directly related to science, who have helped me in this work ever willingly.

Thirdly, I thank the active participants of **the Russian Scientific and Technical Society ("RSTS")** and members of the newly set up **Clubs of New Knowledge named after N. Levashov**, who, sparing no efforts in disseminating the information and "**SvetL**" **Technologies**, made it possible to begin the implementation of my promise given in public – **TO FINISH WRITING** the book that had **NOT BEEN COMPLETED** by **N. Levashov**. And to finish it with their participation, since they are **NOT INDIFFERENT** to what is left for all of us **by N. Levashov, A. Khatybov** and other outstanding Russian Scientists. That is how this book **OCCURRED** through me. In the literal sense of the word. This book has not been written by me – it **occurred through me**. And while you reading the book, I am more than sure that it will **occur through you** in the same way as it has happened to many people while their making an acquaintance with N. Levashov's works, and then with the others, because all of us **WERE LED** to the truth that we had already been ready for "**SvetL**" **Technologies**, perception of them and their application only accelerated this process. And although my heart is **OVERFLOWING** with **GRATITUDE** for everything these wonderful people (Human BEINGS) have done for me, I cannot help mentioning my **MAIN helper, my wife and life companion Tamara Viktorovna Shkrudneva**, a woman with an extraordinary wisdom, an ability for love and compassion not only for me, in all my endeavors, but also for people turning to her for help.

And finally, **fourthly**, I would like to mention the people whom I **HAVE NEVER MET**. However, their very lives and what they had done for the good of the people have had such a strong influence on me that I cannot help **EXTENDING** my thanks to them.

My life would have probably been much easier if I had not mentioned all of this. But my articles, the Knowledge that I have got, and this book, and everything **HAPPENED** to me **NOT FOR** this. And whatever difficulties this would bring in (for instance, I have already been called a blasphemer, a deceiver, and a hypocrite because I had **NOT FOLLOWED** these truths

earlier – or, even worse, – a saint), now I **CAN NO** longer **stop** this process. And I do not want to. I have had plenty of opportunities to avoid all this, and I have not taken advantage of any. I have made up my mind to behave as **my** conscience and intuition dictate and not the way **MOST** people want me to behave.

My knowledge and intuition tell me that this book, all that it is expounded in it, is not nonsense, not the fruit of a tired imagination. All this is **REALITY** of the present day. And if we consider Technologies and specifically "**SvetL**" **Programs**, which are described in this book – what they are "capable of" or "not capable of" (no matter what some people think of it), the **TRUTH** lies in the fact that **the Programs TALK** to anyone who has decided to apply them – to a good one and a bad one, to a saint and a bastard. And, of course, with each of us who has already applied these Programs.

Prologue

Life goes on...

As a basis of the book, or rather, four books as it turned out later after long deliberation, I have decided to take a remarkable work of the Man who called me his associate, "gave" me so much knowledge that my acquaintance with him has become an integral part of my life, and what I have gained from him – **MY KNOWLEDGE**. The work in question is the "**The Mirror of My Soul**" by **Nicolai Levashov**. The events that have happened to me for the last few years seem to "reoccur" the events that happened to Nikolai. Just because of it and for the readers' better understanding of my story, I will "take" those episodes from Nikolai Levashov's book that I consider necessary, and project them onto the present day, the events that happened to me after his "passing away" (I do not want to say – death). This will make it possible to return once again to the information given by N. Levashov in his books, and to comprehend it, realizing that what he wrote about is happening today with many of us and everywhere.

I am also doing this because I have promised to "finish" the **INCOMPLETED third volume of "The Mirror of My Soul"**, which was begun by Levashov just before his death and which is called "**Life goes on...**" **Much** has been **contained in this title** (if you consider it carefully), including the answer to the question: why this volume must have been completed after **HIS PASSING AWAY**, **in what way and who should complete it and for what purpose it should be completed**. This is neither a continuation of N. Levashov's life story, nor some moments of his life that are known to me and that were not mentioned in his writings; although, I will certainly touch on some aspects. I am sure that **SOME** people will **CRITISIZE** me, because they are expecting this book to cover some hidden facts from Levashov's life and the continuation of a certain story about him. But these are neither memoirs nor a biography. These are broodings over the past and the left behind. This is **MY KNOWLEDGE**, that I have got at school, the naval school, the naval academy, and other educational institutions with famous names. This is the knowledge gained at naval and government service. But the most important is the knowledge gained from the outstanding Russian Scientists, who I was fortunate enough to know personally, and from those who unfortunately I have not had the

chance to meet, but whose works I have been lucky to get acquainted with. Having obtained **KNOWLEDGE** (that has become **MINE**) on the basis of those works I **HAS SUCCEEDED** in applying them in practice.

Why did it occur only to me to «finish" this book? **Why DID NONE** either of Levashov's circle contacts or the readers of his books **INITIATE** the implementation of any of his technologies, including the so-called "**Dark Matter**" **Generator, about which N. Levashov wrote and those he was able to create?** Why do some people today disseminate not information from Levasov's works but lies and gossip based on rumors? The answers to many "whys" you will find out from this book.

For me, there is no such a notion as "plagiarism", since everything connected with it is aimed at limiting the dissemination of a true information and strengthening the importance of those who "**produced and is producing heaps**" and laid them on a blank sheet not being aware of one thing: **NOT DOES HE** (the author) write, but **HE** (the author) **IS WRITTEN BY**. How this happens and what is behind it will be told in this book.

It so happened that I had to speak in public and tell about my relation with N. Levashov, about our meetings, plans. and some events, and about what I did and was going to do. I spoke about **the works by A. Khatybov, N. Morozov and other** living Russian scientists, I tried to make it clear to the people that **N. Levashov and A. Khatybov** had known each other, met and exchanged information. I told the people that what they had written in their works, was **INTERRELATED** and complemented one another. I emphasized that All That allowed them to create what they had created.

I also mentioned the **Friends that N. Levashov had and still has** and about them he wrote openly, but many readers did not understand **THE MISSION** of these Friends.

I have written in detail about the Generator (the generator of "dark matter" in his terminology) made by N. Levashov, **how "SvetL" Programs had been created and who had created them.** But very often the information I tried to convey got back to me in the form of a kind of "folklore", being surrounded with such stories that distorted almost everything including the image of Nikolai Levashov. The inventors and distributors of this "folklore", exaggerating and distorting the facts, except for the negative attitude to Nicholai and his activities, did not cause anything else. Were those engaged in it aware of what they were doing? I can say with all responsibility: **YES**, they **WERE** However, a lot of people wrote to me

and just called me or Skyped – those who have already read my articles, - asked me to write about the events that had occurred since my "acquaintance" with Nikolai Levashov. People asked me to tell them about the development of his heritage left to all of us.

And I decided **TO WRITE BY MYSELF** and publish the information that was available to me, tell about the knowledge that was gained and tested, and to go on giving information about those Technologies that have already been working for the good, to relate not only about **OUR COMMON** plans and thoughts, but also about that knowledge (gained from the works by **A. Khatybov and other scientists**), which made it possible to comprehend, create and expand "**SvetL**" **Programs**.

When I began to work in this direction, everything went on its own accord as a sequel of the third volume of his **incomplete work "The Mirror of My Soul"** and my comprehension of what was going on.

I hope I will be able to keep to a certain objectivity. Of course, everything described is going to be subjective reflecting the world around me seen with my own eyes. But for all that I will try to reflect everything as objectively as possible. And since this is a description of what has happened and is happening to me (what and when it happened in my life, what and how I thought in certain life situations, what I felt and experienced that time), better and more accurately no one will do it. But if something goes wrong, it will be a distortion of my own vision, and it will still be better than the distortions made by someone else.

I would like to note that I have never thought of myself as one of the selected. It makes me laugh even to think about something like that attributed to me, based on the fact that I was familiar with **N. Levashov**, and the fact that **HE "OPENED"** my Brain and gave me some kind of supernatural resources that allow me to do what I am doing now. Belief in destiny completely denies Man's free will; it turns Man into a slave of circumstances and makes a submissive plaything of external forces.

N. Levashov "taught" me a lot, and I learned a lot talking to him, studying his works and the works of others, about whom I have already mentioned. **All THAT** has become **MY KNOWLEDGE** that I am able to apply now. I just live **MY OWN** life; do what **MY CONSCIENCE** and my sense of justice dictates me to do. Some like it. Some hate me because of this and still cannot "endure" the fact, that N. Levashov **DELEGATED** a lot exactly **TO ME**. Some fear **BEING AWARE** of my capabilities.

I know my mission is to live and act as my conscience dictates, regardless of getting or not getting any **ADVANTAGE, BEING** or not being praised. And when I encounter some "curious facts", one way or another related to my life, they seem curious and strange to me, and neither more or less. I do not suffer either from any complex of inferiority or megalomania! Everyone is responsible for one's own live, makes one's own choice and takes responsibility for the results of that choice.

After getting acquainted with **N. Levashov**, I was set in motion by the only thing: yearning for the **PERCEPTION** of Nature phenomenon, longing for the comprehension of **PHYSICS** of a living **CELL, PHYSICS OF ENERGY** and **PHYSICS OF THE BRAIN** as well as striving for solving for this or that enigma and accomplishing the tasks set by myself.

N. Levashov taught me to look for an opportunity to comprehend the happening events, to consider any phenomenon in the aspects that no one had ever considered before. Sometimes it was necessary to see the phenomenon not from one new side, but from a multitude: and, what is the most surprising in all that is the fact that I have succeeded in getting the bottom of the matter lately. To be able to do it I had to radically change not only my way of looking at things but myself as well, under the "supervision" of **Levashov** and on my own one after **HIS PASSING AWAY**), and also "under the supervision" of his Friends (when it was particularly difficult). And, as **N. Levashov** said, that was exactly what made me move forward...

Wise is the one who recognizes the limitations of one's knowledge and skills. But the one, who declares that he knows **EVERYTHING**, is able only **TO HARM**. So, as **N. Levashov** and **A. Khatybov** used to say, everything is good in its season!

Lots of what I have been doing, what I had been taught by **N. Levashov** and his Friends, and what I have conceived by myself, cannot be put into the Procrustean bed of the ideas of lots of people, but... Quite a number of them not having the slightest idea of how, for example, their computer, video camera, telephone and a lot of other things work, especially of the processes occurring in the microcosm and macrocosm but nevertheless, they **DO NOT REJECT** them, since these things have been accompanying people since their childhood, and also because people had been inculcated in the thought of their nothingness, that **"man is a miserable creature unable to do anything by himself!"** And besides, only **the Lord God IS ABLE TO CREATE!!!** What is the most curious about all of this: **there is no evidence that the Almighty has created everything, only a blind**

faith! And that is not all! The way God created the universe, including our Planet was changed several times in the holy books, more precisely, the interpretation of the very process of creation. All the explanations of the nature of the divine creation used to appear only after the accumulation of the facts that the Church **WAS NOT ABLE to REFUTE** even with the greatest desire. And in the Middle Ages the Inquisition burned scientists on the bonfires for just being affirmed in the fact that the Earth rotates around its axis and around the Sun, like **Giordano Bruno** who was burnt. Nowadays, the church officially recognizes the existence of aliens and intelligent life **ON** other Planets. This is more and more talked about by the Vatican, which is an irrefutable proof of the manipulation of the people's consciousness and of the one who really stands behind the so-called "Almighty"!

Does the Church and its "ministers" play any significant role in what is happening today? I will not comment but just give you some figures. **Since 1991**, there have been built and **OPENED 20,000** churches and **CLOSED 23,000** schools. And No one but **N. Levashov and A. Khatybov** described the essence of all this in an intelligible and irrefutable way **in their writings**.

Do not be lazy, read and make conclusions of your own – who makes profit inculcating in people their being wretched and sinful from the moment of their birth" and are not capable of anything" but an obedient submission to the elect of "Almighty" (That **DOES NOT EXIST(!)**). Who benefits by **HIDING** from the people the possibility **of development to the Creator's level**, only not in the way as it is described by social parasites in the texts fabricated by them?

People – Human Beings! Start thinking with your own Brains; stop listening to other people's explanations, besides being absurd ones! A lot of things will become very clear if you develop yourself correctly. And what was attributed to Gods will become possible to Man! Yes, for the Man who has reached the level of creation, I emphasize, – perceived Creation! It is but necessary to go through all the stages of the development; as they say, **"it's not the Gods that burn the pots!"** I do not think I have managed to go through all the stages that **N. Levashov** had mentioned. But I know that I am going the right way. And the results **PRESENTED TO THE PUBLIC** confirm it.

Anyone can have one's own original ideas, plans leading to **COGNITION**, and the itch to properly develop very self. The main thing is

that once you take that **PATH**, do not quit the next day, month, year. Work at a pace that you are able to keep constantly. Observe the sense of proportion. You should **BE AFRAID OF** only one thing – **TO BORE** people with the unwanted actions. Avoid fruitless disputes. Spend your time on getting **KNOWLEDGE** but not on empty **DISPUTES**. And you certainly should be aware of the fact that deliberate denial of the truth is a betrayal of yourself. This is the way you should go if you want to move from the category of people to the category of Human Beings.

I have pondered for a long time about the sequence of information presentation that I possess, thinking of that knowledge that I would like to share with the readers. After **N. Levashov's "passing away"** a short time elapsed if measuring the phenomena taking place nowadays. But this time is full of many events within the framework of everyday understanding. Of course, I would like to tell a lot and share my knowledge with the readers in the same way as **N. Levashov** did. But where should I start? I have made up my mind to start with a common name of what I want to set out – with the name that would contain everything that this book is to consist of, with what that **N. Levashov DID NOT HAVE TIME** to write; with the explanation of what **A. Khatybov stated**; to show **HOW MUCH COMPLEMENTARY** are the works of these scientists who discovered the information for us that is "to be transformed" into our knowledge. But there are many people whose Brain is not able to perceive it, – and not because people are stupid, but because very few of them understand **WHAT EXACTLY** the **BRAIN** is.

Over the years, there have been written a lot of articles in which I wanted to explain to the people what heritage **N. Levashov left** for us in addition to his works. It was written and told in the framework of today's possibilities about how the Generator of "dark matter" had been created and applied; what **"SvetL" Programs** mean; how they had come into being and the way they had been modernized, tested and applied that day; how the name of **"SvetL"** was put in an appearance. All this was decided to be summarized in the collection **"Knowledge from the Origin,"** which was released in **2015**. But it was necessary to find a common name combining the works both **of N. Levashov and A. Khatybov** with some new works that would make it possible to develop this **HERITAGE** and apply it in life, as well as to provide "help" in **EVOLUTION** of the Brain, which is by no means unimportant today. However, whatsoever and whoever may talk about it, it turns out, that there is just **no way anywhere without the Brain.**

It is important to realize whether the Brain affects the life of a person. It turns out that we do not have a true notion of what the Brain is. We cannot see the Brain under a microscope or cut it with a scalpel. We actually **HAVE** a **VAGUE** idea of the Brain. And in order to perceive it, as **A. Khatybov** used it say, "**you have to have a Bath**". That's the way the name was born, uniting everything that is going to be written here: **N. Levashov's "SvetL Broom" in A. Khatybov's Bath School and a Labour Spade "**

You are going to get to know: what **N. Levashov's "SvetL Broom"** is and what it is for; what the "**Bath School**" is and why you should go there; What a "**Labor Spade**" is and how to use it.

Often it is easier for an intelligent person to open a new truth to the world than to realize why others do not accept it. I have long been convinced that no matter how hard I try to be understandable; people still are not able to part with the usual clichés overnight, especially if their **CONSCIOUSNESS** has lost its elasticity and is stiffened, which is typical of the older age. It does not want to part with the **MYTHS** put into their heads. I will try to break these clichés, return to the standard consciousness of people their Human properties and that world outlook that has been deliberately hidden for millennia.

Today Man has two ways to go. **ONE** is to abandon all reasoning about the foundation and nature of the society, merge with the crowd, hunting for bread and shows and surrender to the will of the elements. **THE OTHER** is to go further into the matter, the causes of our troubles and build up a modern system of knowledge; to create the system based on the knowledge of **those** who ran counter to the so-called modern science and who stood and still standing at the source of **NEW KNOWLEDGE**, that are destined to bring the Humanity out of that abyss and darkness into which people were deliberately immersed.

There is reading caused by emotions, and there are emotions caused by reading, which is more important. But there is also a **HUMAN MIND** that emotions interfere with. There are many who have already realized that we need information (out of reading) and the Mind for accepting (or not accepting) this information. Lots of people when reading **N. Levashov's** works paid attention to the fact that with the first reading they got at one meaning of the text, and then, re-reading, they conceived the text in a different way, that was much deeper and more meaningful. Practically all the information from **A. Khatybov** and **N. Morozov**, on the sites of the

Research Institute of "the Centre of Preventive Strategies" and "RSTS", is also given in the "framework" of the resources of your Brain.

What you are reading right now is the **SECOND FULL VERSION** of both books, completed in **March 2017**. But you make an assessment of what has been done after getting the results. After getting down to the writing of the book and publishing it chapter by chapter on my website, I began getting letters from the readers. They sent their comments and expressed their wishes: which information was not sufficiently covered, and which one was missing. All these numerous questions, requests and clarifications are taken into account in this edition of the text. It turned out to be voluminous and, to my opinion, not very convenient in cognition. Therefore, I made up my mind **to make 4 books** out of all the written material, which, on the one hand, are independent in their comprehending, and on the other hand, they **ARE SEQUELS** of each other, and what is important, they are sequels of the third volume of **N. Levashov's "THE Mirror of My Soul"**, as it was promised. I'm sure that the readers will appreciate it.

Time is running fast. Some Information is becoming out of date, and in this edition I will try to cover all the trends you wrote to me about, and in addition, to make supplements for better comprehension.

One of the deepest secrets for Man is the perception of the very fact of the physical process, under which both the harmony of the internal states of the functioning Brain and external states of its control are being formed, representing stage-by-stage growing perfection of the states of Consciousness and Mind. The Human Brain creates its own version of reality. The world that you see and hear around you only seems to be so. In most cases what you see and hear is not quite real. You perceive only a tiny fraction of what is actually happening. You get an **IMPRESSION** of a wide panorama before your eyes, but **REALLY** you see no more than the size of your own fingers at arm's length. The rest of the space is filled with imaginary reality since your Brain creates stable conditions for you. Although you may think that you are the Man and the captain of your ship, however, many processes are controlled by those who surround you, and your environment. You cannot trust your own Brain. But if you care nothing for your Brain, you have to go to the **"BATH"**, and beforehand to read this work in order to have an idea what **"BATH"** means, how to use it and why you should "go" there. And for this you **NEED N. Levashov's "SvetL Broom" in "A. Khatybov's "Bath School" and a Labor Spade.**

Introduction

Getting down to this work, I proceeded from the fact that a good book puts in good order the available knowledge. It takes our thoughts out of the consciousness, pulls them out of the corners of the subconsciousness, extracts from our heart and sticks them together to make **NEW** knowledge. As a result, a new "4" is given rise from already existing "2+2". New, sprang up of the existing, is **NOT** supposed to **BREAK** the harmony of the former. Thus, in my opinion, the worldview becomes more complete and clear.

For those who has read **N. Levashov** and proceeded to **A. Khatybov** (although understanding little from the above), who persistently advances in his knowledge, it would be worth taking the bull by its horns, and get at the meaning of **the Bath**. But to be objective – are there many such ones now? The undoubted majority is hardly capable of adequately perceiving any Genotype of the Brain, an incomprehensible albedo and frequency ... And ebro-spiders, the Earth capture and their Control System (SEC), are not "our" Sun and Moon? And about **a LIVING** cell, and who and where "got in there and what for" it is not of this world. Where is the sequence of events (in the form we "were taught") backed up with «advanced studies", artifacts and "world known" names of "explorers"?

When **REFLECTIVELY** reading **Nikolai Levashov**, everything is logically «being revealed «to the reader, and well grounded that can hardly be refuted, and all the material is outlined in succession. You **CANNOT** find all this in A. Khatybov's (as a result of the ban on most of his works). I do want to give information that is to be turn into a **NEW** knowledge of the one who reads it. It's like an emergency aid, suddenly stopped before the very nose of a lost person with no hope to survive. But this new knowledge is not collected together, it is like a heap of garbage, which is lying around. Should it be assembled – and there comes out a miracle of technology. Those who master this technique will no longer turn to someone else's help. This is what I would like to convey to the reader.

I got at a noticeable conclusion: people are mostly **READY** for a **NEW** knowledge, **BUT** the logic of **GRASPING** this knowledge is ineffective. This explains the fact why disputing such topics, even among those "**WHO PERSEIVED**", do not lead to anything. The debaters being preconceived believe that **THE MOST** important material is presented in a non-logical

way, but they are not even able to determine what is the most important. It only means that the ideas should be set out logically, so that the reader could clearly understand whether to accept the information or not to. To explain the complicated in a simple language, it is not enough to feel the truth yourself; it still needs to be understood. To talk to people thinking in the habitual categories on a large scale subject, is the same as to talk to children. Most people, no matter how smart they are, will **NOT TAKE** it seriously. Having been convinced of this, I returned to this subject in our talks with N. **Levashov**. The fact that someone is well informed in nuclear physics or mosquito leg testifies to the presence of intellect or intellectual resources, but **NOT THE SCALE** of thought. An intellect without large-scale thinking does **NOT SOLVE ANYTHING**. Thought is a product of knowledge processing! Man gives birth to a thought. ***A thought makes a MAN, because in the beginning there was a thought, and not a word. The word was after.*** It is not possible to do something that you did not grasp on a large scale, because you will not believe in the reality of your doing. And if you do not believe it, you will consider it nonsense and an empty fantasy. This is what happens with many who is trying to "comprehend" the "technology of creating **SvetL**" **Programs**. It is a perfect example of moving forward in the understanding of cause and effect, on the basis of which we will move to cognition, not before we are summoned to the **Bath**.

And we will be summoned to **the Bath** without fail, I'm absolutely sure about that. Because each person is absolutely **SELF – SUFFICIENT**. **He knows everything**. This was emphasized by N. **Levashov** and A. **Khatybov**, and I have been convinced of this. But a Man **HAS NO TIME** to put in good order his knowledge and thoughts and to get at the meaning of the new. There is no move **FORWARD** since there are too few "promptings" and clarifications. Start acting! That's what you are supposed to do. Act right here and right now. **DO NOT BE SLOW AND DO NOT ARGUE** about the causes and consequences of your actions in solving so large-scale tasks facing you. Start with a little – then there is an idea: it needs to be changed; start something new or finish the old one. You might need to catch up with someone, find or leave, help or just hug ... You feel like saying something to someone who is close by or not close by, or wants to be close by...

If there is something that requires your participation in order to move on, act then: speak, look for, fight, struggle, but **DO NOT BE**

INDIFFERENT. Take an action! Because the world needs your diligence.
Take my book as a **PROMTING AND CLARIFICATION.**

Chapter 1. The planetary level of secrecy, or "the operation of disclosure"

People take for the truth not that is true but what is understandable. The truth set out unclearly is taken as a lie. Intelligible interpretation is of principal importance.

Taking for the truth the conformity of certain provisions to certain criteria of verifiability (as in philosophy, for example), people limit themselves with these criteria, **HAVING NO** opportunities to expand the boundaries of their reasoning in view of the fact that they quickly go over those boundaries and indulge in what that the majority defines as **MEANINGLESS FANTASY**, but to put it simply, nonsense. On the other hand, criteria of verifiability must be at least greater approximation to the truth than their being checked provisions, and the latter also have to be checked with something. In conditions, when the thought rushes forward and deep into the distance, covering those areas, the essence of the content of which there is nothing to check with, there might happen a crisis of thinking that is able to turn into something new by expanding the scope of consciousness, or, in case of strict observance of the rules and laws prescribed by tradition and way of life, the circle closes and there will not be any search or movement to the truth. In the end, the old, currently existing criteria of verifiability, intended to serve as the instrument of knowledge, limit it easily, transforming the primordial Human aspiration for the truth in the plowing of the most affordable top layer of the observable reality.

* * *

On the sides of the spacecraft "Kennedy" there were placed two engines 5 feet wide each. The designers of the ship wanted to make these engines even further, but were not able to. Why? The fact is that these engines were transported by rail, which passes through **a NARROW** tunnel. The distance between the rails is standard: **4 feet 8.5 inches**, so the designers could make engines only 5 feet wide. The question arises: why is the distance between the rails is **4 feet 8.5 inches**? It turns out that the railroad in the United States was built similar to that in England, and England made railway carriages on the same principle as trams, and the first tram produced in

England in the image of the team of horses. And the length of the axis was **just 4 feet 8.5 inches!** But why? Because the team of horses was made so that their axes fell into the ruts in the English roads for the wheels to wear less, and the distance between the ruts in England is just **4 feet 8.5 inches!** Why so? Just because the roads in Britain had been built by the Romans, bringing them under the size of their chariots, and the length of the axis of a standard Roman chariot was equal to... that's right, **4 feet 8.5 inches!**

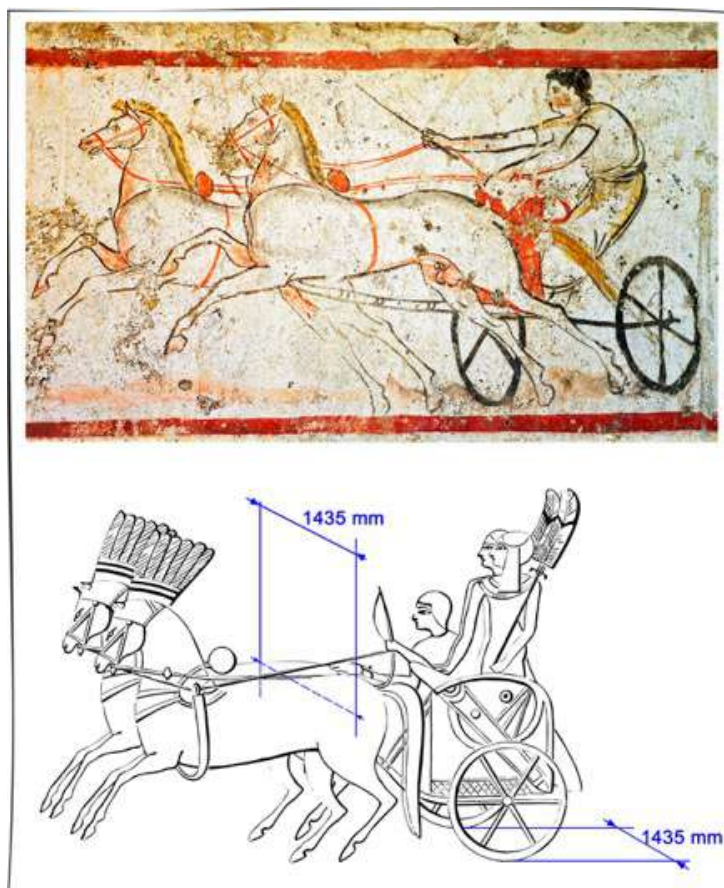

Now, we have got to the bottom of where this width comes from, but still why the Romans decided to make their chariots with axes of this length? And here's why: in such a chariot normally there were **TWO** horses harnessed. **And 4 feet 8.5 inches** is the **SIZE** of two horses' asses! To make the long axis of the chariot was inconvenient, as this would violate the balance of the chariot.

Therefore, here is the answer to the first question. Even now, when Man went into Space, his highest technical achievements directly depend **on the size of a horse's ass, as it was two thousand years ago.**

Let's take this "method" of comprehension and apply it to the information presented here. Let's go back to the events happened many thousands of years ago, that is quite possible if you understand that time does **NOT EXIST**. To move forward, you have to look into the past. So that you could "look" into the past, you have to be prepared; otherwise you would rather not however much you wanted. Time was "invented" only for our convenience, with our so short life. **Time does not exist, but there is physical-biological process in which it is possible to "enter" and move "back" and "forward"**, but before that you have to **TAKE the Bath**. Those who "has not received an invitation to **the Bath**", it is **NOT RECOMMENDED** to do it! You may come in if you are a Nobel laureate, in physics for example, but to come out – you will fail for sure. It has been proven.

1.1. The Beginning

"Where is the information from?" – you can ask. From **Alexander Khatybov's** encoded messages, confirmed in the writings of **Nicolai Levashov**, and by those real events, not to make notice of which is just **IMPOSSIBLE**. As **B. Makov**¹ has told, and **A. Khatybov** himself wrote about this, **during 1992-1998**, it was "accepted" and encoded **1652 texts** and at the same time, transmitted **772 texts**. However absurd it sounds at the beginning of the book. The deciphering of the texts "was made" with the help of the well-known method of **"Kaleidoscope"**, and therefore there is such a **CLEAR** and **UNDERSTANDABLE** "picture" of the past, independently confirming everything that was written by **N. Levashov** based on his own experience and that of others.

Most civilizations in the Space are at a **QUALITATIVELY DIFFERENT** level of evolution, when information is transmitted and received not via radio signals, but mentally and holographically, and to be more precise, visual-graphically nowadays. Thousands of signals from the Space are transmitted from other civilizations in the form of volumetric holograms directly and via the Control Complexes. There is no need in making contact. It exists in a specific realization, especially after a full stop and termination of all previous Control Systems and replacement in **2012** of the interventionist Programs for the original Programs of "the revival and

¹ B.V. Makov – the Director of Scientific Research Institute – The Centre of preventive Strategies.

reconstruction" of everything that had been on the Earth twenty thousand years ago. But most people do **NOT UNDERSTAND**, do not know and are unable to obtain this information. Those who can translate this information into other languages so that to make it **INTELLIGIBLE** to other people (the works by **N. Levashov, A. Khatybov** and others). But, unfortunately, even in an accessible form, this information **is REJECTED**... The same happened with **the third Appeal to the people of the Earth by the Coalition Team of Observers C. G. O.** (Association of civilizations of our Galaxy) passed for the people of the Earth **in 1929, to E. I. Roerich and N. K. Roerich** by Shambhala intermediaries. This appeal was **just ignored**... Who is still interested can get acquainted with **this Appeal in Levashov's book "Last Appeal to the Mankind"**. And as for the others I would ask you not to worry. Because it is too late to worry and there is no reason.

Let us emphasize two ways. **The first one** is to abandon all reasoning about the foundation and nature of society, about new knowledge and perception, mix up with the crowd, being eager for bread and shows, and surrender to the will of the elements. **The second one** is to grasp the essence of what is happening, in the causes of our present day misfortunes and to create for ourselves a modern system based on **NEW KNOWLEDGE**, which is supposed to include what is being narrated here.

I would like to draw the readers' attention to the fact that this information had been concealed from people for over the past 18 thousand years. 4 years ago, it was **UNTHINKABLE** to obtain this information (it was a planetary level of **SECRECY**).

* * *

The earth is **ARTIFICIALLY** created (**for 10 billion years**) formation to ensure the existence and evolution of life. **The Cell** (life) is also an artificially created formation, the existence of which is determined by the beats of the Earth. **The Earth** has its own "computers" and Complexes that make up **the Earth Control System (ECS)**. In turn, **the ECS** cooperates with the higher Hierarchy of the Universe.

ECS is a self-developing System, Controlling the Earth evolution and life support created specifically for our Planetary System (later it will become clear why our System is not called Solar System). One of the principal of the **ECS** tasks in ensuring the existence of life on the Earth is the maintenance and generation of the beats (a kind of quartz Generators) for the life of the

cell, organ, organism, community of living beings, of Man and of Human community.

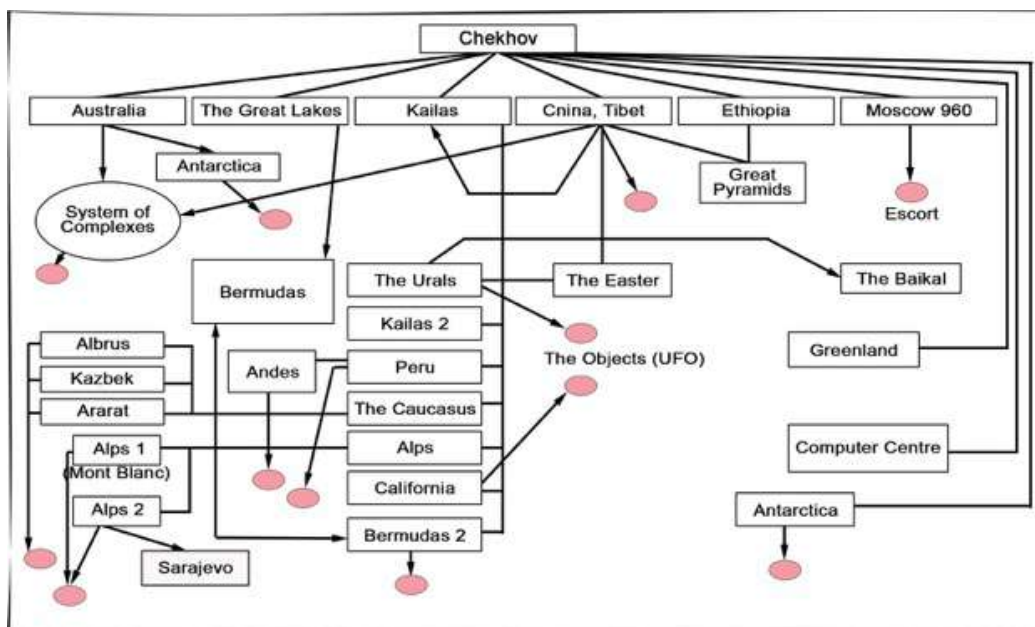

Some beats provide life cycles of the cell existence; other beats ensure co-existence of cells and so on. The beat frequencies of the Control System far exceed in frequency all conceivable physical variations (and go as far above as "the astral-mental frequency" to cone phrase).

It looks like science fiction! But in the search for additional evidence of the possibility of such creations, let's turn to **N. Levashov's** writings: "...an artificial planet of an enormous size was created, but that's not all. The Created **White Star** was able, curving the space around itself, instantly find itself in that Universe – petal or in that matrix space, where there is some need in help... This is the only one in its kind, a **CREATION** of the **MIND**, which moves through space not by itself, but, as you can say, moves the space itself. This creation corresponds to a well-known saying that "**if Mohammed won't come up to the mountain, then the mountain comes up to Mohammed**". And if a proverb has a figurative meaning, the White Star actually does it. A specific spatial **GENERATOR** changes the space around the White Star so that the space-universes one after another "are superimposed" on the White Star, and we can only set a task which space – universe it is to stop, and... the White Star finds itself in the right space of the universe."

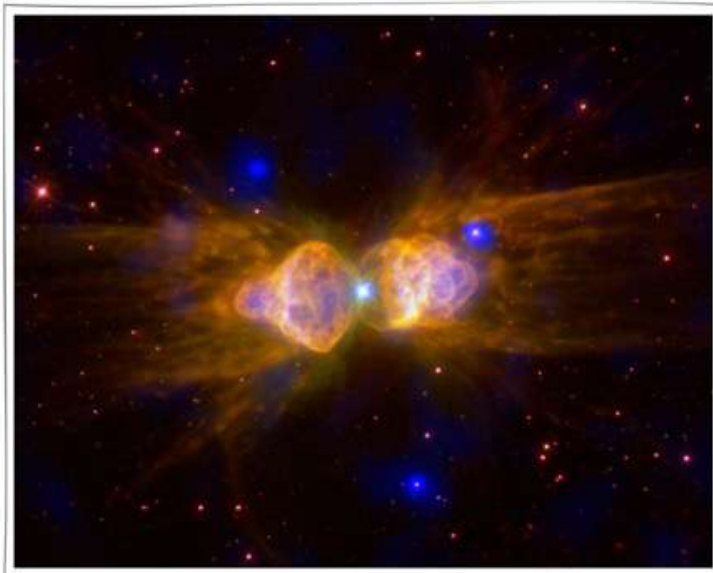

It also seems to be fantastic. Then refer to another Chronicles document– **the Slavic-Aryan Vedas:**

"The tribes were helped by the Power of God,
Blessing their lives for the common good ...
The Race was supported by the cherished Source
That remained in the tracts of the ancient...
The Gods foresaw the Darkness on Midgard
And Race decided to help the descendants
These events took place in the ancient times
When three moons over Midgard shone.
The Source has been placed in the bowels of the earth
But in peculiar tract the access was hidden.
In the depths of the earth, it accumulated the Power,
In different places It came into being.
But the Source of eternal divine Power
Not every space of the sacred Race flowed,
But only in places where, in line with traditions,
Midgard Gods Life Force inserted...
They bestowed upon the World the Divine Sense
For great achievements their kin directing..."

Here it is also mentioned a certain "Source of Life", which was placed in the heart of the Planet, and **a certain «Generator», set by the Gods.**

And if this information is not sufficient to satisfy the skeptics, you can take the "**Book of Books of all times and peoples – the old Testament or Tanakh**" in a somewhat abbreviated form. According to the Bible, **for seven days God has created** the heavens and the earth,

separated the waters from the land, worked on the creation of different plants and animals, created Man out of dust (the matter composed of atoms and molecules, like everything on earth) in his own image, and on the seventh day went to rest, satisfied with his good deeds. It also indicates the act of **CREATION**. *Although everyone gets it in one's own way.*



It is not by chance (according to the Bible) to create the Earth and Life on it... it has taken God **SEVEN DAYS** (day – light time of the day, rich in the spectrum of the primary matter (photons), but in the sequence of their qualitative and quantitative composition). As it is known, white light in its decomposition splits **into seven colors**, seven primary matters form a dense substance of our Universe, and the planet, respectively! And that's what was the result of their successive superposition:

But why do the work, which is easily done by Nature, under the corresponding conditions for the origin of life? Probably "something had happened" to the Universe and after that it was possible to start a "new experiment" taking into account the Knowledge "of the nature of the processes of matter formation", which more advanced civilizations **WERE ABLE** to carry out. More **SOPHISTICATED** systems for the evolution and preservation of Life on the Planet have been artificially created. In the ordinary course of the star-planetary System, the planet was subject to various threats from the matter conversion of the Cosmos – the explosion of

supernovae, flying "shards" of the Planets in the form of asteroids and other Space "riots", as well as from the objectively existing parasitic civilizations.

The planetary Cluster System² besides the Earth consisted of: ***Mercury, Venus, Mars, Phaeton, Jupiter, Saturn, Pluto, Neptune, and Uranus.*** Each of the Planets had a particular function provided to it. For example, the System of planets did **NOT NEED** the Sun (there wasn't one) as a multifunctional generating system that provided the formation of control-energy radiation frequencies. On the Earth there were **364000 objects** to ensure **EVERYTHING** required for the complex control and harmonious **EXISTENCE** of energies, performing a process of civilizational development, and providing habitat conditions. The light had the 80 octave (the current lighting with the participation of the Sun is the 48 octave), gravity was of 5.82 m/s² (this fundamentally changed the whole arrangement of life for the Human, metabolic processes of the body and many other things in the state of reality).

That Planetary System was created for the development of PERFECT MIND, to reach by Man being on the Earth, **the TRUTH** about **Consciousness, Mind and Matter**. It was decided to realize this goal on the basis of the **Living Cell** in the **PROPER** evolution of the Human Brain under specially prepared conditions of life-attending **System of the Earth Control (ECS)**. This had been realized **LONG BEFORE** the forcible entry of parasitic civilization – the invaders from Darkling worlds.

1.2. Before the "Capture"...

Each planet from the Overall Hierarchy of Civilizations with the endowed living conditions, has to **HAVE** in its model design a certain required "set" of controlling, providing and attending Objects and Complexes, which being formed in the functional cluster³ Systems **have to be able to:**

² Planets clusters additionally invested power in developing civilization of intelligent orientation; their Control System consists of: Control Complexes, objects, Systems of energy-information transmission and communication which in total provide and retain in stability the control energies – the Mind.

³ Cluster is unification of several homogeneous units, which can be considered as an independent unit, possessing certain qualities, being common for each associated element. For example: celestial, galaxy, civilizational, planetary, cluster of public development. Control of every sphere of being, as separate

- provide autonomously the entire incremental process of controlling the development of **THEIR** Civilization on previously acquired from the outside program;
- to retain the **LIFE EXISTENCE** energies in a harmonious state with respect to each other;
- form the energy **SUPPLY** and "recharge" their existing energy concepts, etc.

Such a planet as the Earth is a kind of complex strictly identified planetary monocluster⁴ (with its own control of the existing energy and the development of civilization of Intellect orientation), which in line with the **PROVIDED** programs should be fully in harmony and interact with the help of the control system and provided functions, with cluster systems of **HIGHER** development in the course of its long evolution (8 stages).

The Earth is a set of models represented by the energies that are in the inertial (material) and no inertial (immaterial) states of aggregation of matter ranging from **12 to 512 octaves of the energies** for the **GIVEN** stage of civilizational development as the first stage of a nested program for its **DEVELOPMENT** in general. Our Mother Earth is not that simple as it seems to the present-day geophysics and, especially, policy-globalists, who has turned it into the field of getting profit for their earthly blessings (not with their own brain) as a result of their destructive irrational orientation!



lower elements in general Construction of people's being; it is also expressed with quite specific functional people's being.

⁴ Planetary cluster is a thoroughly adjusted model Construction of a separate planet, presented as a complex of energy gratings of the whole range of energies in their material and non-material relative stability.

The whole Earth System⁵ previously exercised its **Sirius**-oriented movement at a distance of about 240 billion km (for the Earth). The orbital model of arranging the whole Cluster System of the Earth was completely different, and the direction of the overall movement was not oriented to the Polar Star in the constellation of the Great Bear.

The main parameters of the Earth before the attack were:

- the inclination to the Ecliptic plane is 25°;
- day and night = 48.64 hours;
- a year =864 days (with respect to quantum fluctuations of the charge =1,007 sec.);
- the height of the gratings of the original Design of the atmosphere amounted to 12.000 km;
- the number of layers of the formed gratings of the Atmosphere was 18.

The level of the surface layer of the Earth had been almost 11 km below. The shape of the planet was more close to the shape of the ball; the present array of rock formations and other new built "garbage" had not existed. Unlike the intervention's design of the Atmosphere (now existing), the construction of the original one had been significantly different both by functions and in the structural plan. The construction of the gratings had started from the hardest of the plates, i.e., the Atmosphere had begun and built up over the plates (the hard coat). In the gratings of the Atmosphere there had been so-called "The atmosphere Brain."⁶

Before the intervention, the Earth had deservedly been defined as the **GREEN PLANET** and the «tourist Paradise», because there had not been any all-destroying enterprises in this similarity, especially smoking chimneys, since all the technology of the reproduction sphere had been based only *on the use of the energy received from the environment. Most manufactures of any product of any scale had been based on the technology of the model synthesis in the high octaves of the energies* with converting the created models to the physical plane in the end (through lower octaves of energy in the material plane, i.e. metallurgists

⁵ The System at the Cosmic body is created for the formation of that kind of biological Structure that, entirely is able to be under the System's control and to carry out the System's program.. The goals of the System: to ensure the performance of the Programs; to carry out Regular control of the Programs fulfillment.

⁶ The atmosphere Brain – Informations blocks formed in numerous chains so that to ensure and create various informational bases and structures united into a single System, and placed in the heights range from «-2400 m» to «12400 m».

had not been required, and metal working lessons at schools had not been practiced).

There had not been any oil, gas, peat and other stuff, not any sulfuric mud, and, especially, the technologies of combustion on the basis of sulfur.

There had **NOT BEEN** any diseases on the Earth, since the structure of **DNA** had been in the state of full activity, i.e., the operation of the cell of the flesh had been carried out in the full model state of all **FOUR** codons of DNA. ***This provided biological existence in the physically plan of the proto-Human up to 1300 years*** in the active mode of his useful cooperation in his being (however, it should be taken into account another length of day and year). A more developed Person, who for some reasons "was endowed" to develop others, had been able to exist in his physical form **for 10, 15 and 20 thousand years.**



A year ago, Israeli scientists published a public report in which the results of studies demonstrating that Human cells in **OPTIMALLY** favorable conditions **EXIST** up to **35 thousand years!** Note, the intervention System has **NOT** been **ABLE** to reach the secrets of the fourth codon of DNA, so, despite the populist achievements of geneticists and gerontologists, to extend the biological existence of the flesh cells was a failure. Moreover, at such low octaves of the Brain of the present people (maximum at the 63 octave) biological life extension longer than 125 years is not possible⁷. The solution of this question I "did seek" by upgrading and improving the **Program "SvetL"**. Only an increase in the level of at least up to 82 octave will make it possible to **extend biological life to 250 years.** But today a significant "step forward" has been made. There has been

⁷ Every biological object on the Earth gets its own life support system with birth, when loosing its ties with the organs (e.g. pericardial system) the brain stops the heart. The executive mechanism of the Brain is laid in the skull and in the stem of the spinal brain. The Centre regularly provides information TO ALL, and if the Brain is able to "pick off" and process this information, the biological structure is of rather high informational level. Only 4,28 % of the Brain are operational. The spiritual development of the Brain is contributed to its evolution (not religion).

found and **BUILT the Bath**. But as for being taken there or not being taken – it is another story!

As I previously mentioned in order "to make you happy" – exactly the geneticists and gerontologists of Russia through trial and error will be able to solve this problem; the first positive steps towards this have already been made.

1.3. Parasitic civilization – Ebrs

Six million years ago from ANOTHER space in that area of our Universe that now we consider as the Great Bear, there came into being a system of star groups of EBRs civilization.



Ebrs is the **EVOLUTION** of the protein **MIND**. In the material embodiment they are spiders of **2.5 to 4 meters** high, depending on their existing hierarchy of membership (for comparison, the height of proto-Human did not exceed 1.88 m).

For 5.5 million years Ebrs civilization had studied our Universe in order to find the opportunities to enter into the Community of Intelligent Civilizations of our Universe. But it was impossible to achieve that. So the decision was made to start active (violent) actions with the same purpose – to enter into the Community of Intelligent Civilizations of our Universe, but by pseudo-evolutionary **TRICKS**.

Before "attack", Ebrs had studied the structure of Space, got to know the Golden ratio and principles of redesigning the biostructures.

There began the approaching of ebrs system Starfleet from the Planet Sur (the area of the star **Megrez δ**) from the constellation of the Big Dipper (lat. URSA major) with interplanetary System of the Earth.

The Big Dipper (lat. Ursa Major) constellation is in the Northern hemisphere of the sky. Seven stars of **the Big Dipper** compose the figure that resembles a dipper with a handle. Two of the brightest stars, Alioth and Dubhe, have the luster of 1.8 of apparent star magnitude. By the two extreme stars of this figure (α and β), you can find the **North Star**. The best visibility conditions are in March-April. IT is seen on the whole territory of the Ukraine and Russia.

The Big Dipper is the third largest constellation, the seven brightest stars of which form the famous **Big Dipper**.

All the stars of the **Big Dipper** have their own Arabic names: **Dubhe** (α of URSA major) means "bear"; **Merak** (β) – "loins"; **Phecda** (γ) – "thigh" **Megrez** (δ) is the "beginning of a tail"; **Alioth** (ϵ) – the meaning is not clear; **Mizar** (ζ) – "the sash" or "loincloth". The last star in the handle of the **Dipper** called the **Benethash or Alkaid** (η); in Arabic, "al-Kaid Banat our" means "leader of mourners".

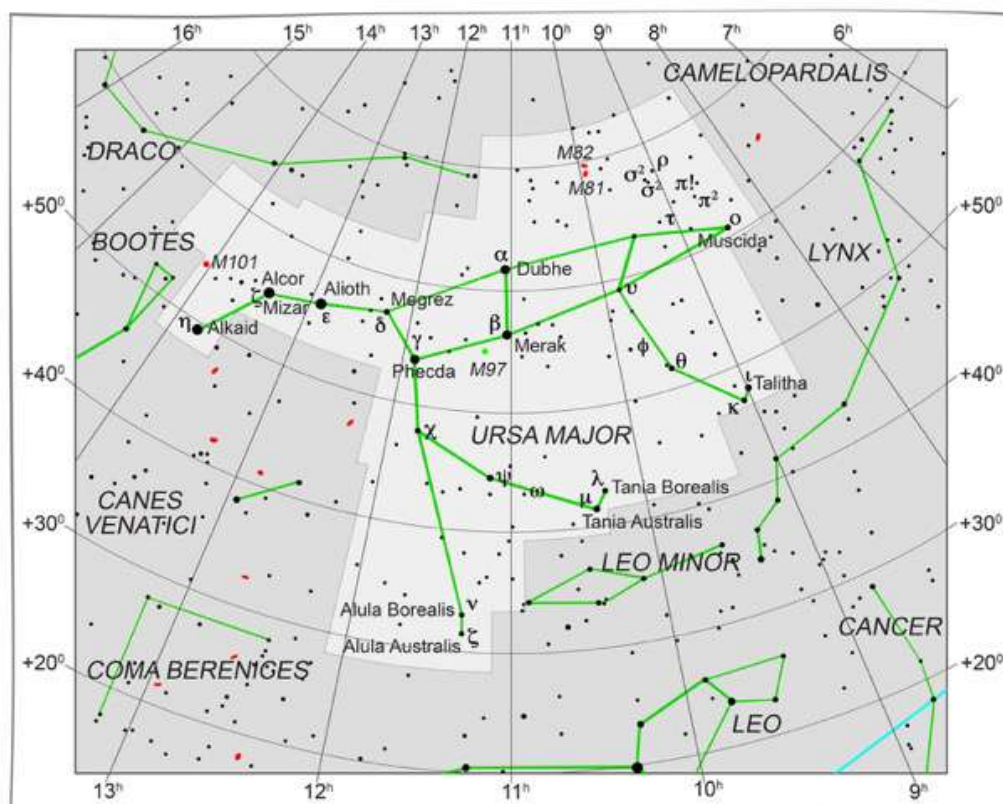

The approaching of Ebr system Starfleet in the constellation URSA major of the planet Sur with the Cluster Interplanetary System of the Earth began **26844 BC**. The Starfleet included: 1 planet the Sun, 3 the moons (Brain), 12 main objects of type 960, 54 satellites, 3862 objects of attack type 440 with the technical means of destruction.

The approaching continued for 8.5 thousand years.

1.4. The Attack

THE ATTACK at the Cluster interplanetary Earth System occurred **in 18344 BC**. At the Earth itself – some time later, i.e. at the **FINAL** time of **the TOTAL INTERVENTION**. The process of intervention should not be understood as a transient form of some of the fighting (Lots of fire by Hollywood scenarios, supersonic aircraft and clan contradictions of some of the lords, Hierarchs, etc.). *The capture process was carried out for 1040 years.*⁸

Ebrs interventional System did not have well concentrated operational and universal "build up" on any of its planets, taken for the accomplishment of the intervention. All minimally restricted, necessary and indispensable set of operational Complexes, and Objects to create such a control cluster, they had scattered simultaneously on several of their imported "satellite objects" and on the planets the Moon (**there were 3 moons** – Month, LELA and Fata), the Sun and other planetary objects. In addition, a large part of interventional planetary objects at the time of capture of the Earth **had been DESTROYED** by Phaeton (as the former element of the original mega cluster of the planets of the Earth modeling complex).

To gather all the necessary energy technological integrated cluster state of operation on one of the planets was **IMPOSSIBLE** for their level of technical perfection. But the Earth practically possessed such necessary perfect set independently. In addition, on the home planets, previously representing together with the Earth, an interplanetary cluster complex, to which now astronomers have given the conventional definition of "parade of planets", there was assisting and complementing set of the control

⁸ (The growing tragedy of the situation or evolution of the "forcible entry" into Nature?) Moscow. 2013.04.07.

complexes and objects being a single Model cluster complex of the Earth for its development for all forthcoming eight stages of civilization evolution.

It is for this reason they (the invaders) needed such a planet as the Earth. Associatively affecting the Earth with all of its imported technology and energy opportunities they **Would BE ABLE** to **CREATE** for themselves acceptable conditions of their own program simulated existence, parasitizing on the captured structural and energy opportunities of the Earth and its entire model complex (**only 12 planets without PHAETON**). So interventional blow to seize was applied to the whole Model complex. But after that capture the process of their own settlement began, and not only on the Earth, i.e. conversion and adaptation of all and everything.

The Control system was carried in the closed "thermos" like the Moon. The caravan consisted of hundreds of such Moons. The caravan was accompanied by "protection" that could eliminate the resistance of that part of the habitable Space, where the convoy would decide to settle. If the Parking lot looked attractive, it was included in the convoy and driven back home. That way acted those who arrived to the Earth System Planets. ***The system consisted of 12 planets.***

The purpose of the parasitic capture:

- the seizure of the Earth and getting it as an "energy pill";
- access to more energy-intensive sources due to perception of the mystery of the living cell;
- penetration into the secrets of the Human Brain.

A LOT of these the invaders have **MANAGED** to **IMPLEMENT**.

The sun is a planet, imported into our System (with the Moon), the diameter of the Sun is approximately equal to the diameter of the Earth. Our SVETILO-LIGHT (Jarilo)) was gone out and replaced by the Sun, which had an atmosphere with a thickness of about 2000 km, consisting of a mixture of oxygen and chlorine. The sun is hollow inside; there is life only inside (like in a shell). There is everything necessary to sustain the life that the aliens wanted to do all around our System. **The Sun had 231 objects, 127 of them are objects of type 440.**

Taking account of the objects it was roughly calculated the number of spiders (up to 4 meters high). **They turned out to be 1.200.000.** They all waited for a landing on the Earth. There were formed linking tubes of all the planets with reference to the Sun. Actually another space was being created that led to changes in the Earth's orbit (the orbital period of the Earth around

the Sun became 365,5 days instead of 630 around Yarilo). It was formed a protection ring around the contour of the Earth's rotation. Inside the contour there were formed the tetrahedral link tubes. The rest of the planets were locked to the Earth and had tubes of dodecahedra tetrahedral structure. All the outer planets were surrounded by the remaining escort.

After the formation of the cone the motion to the 4th star of the Great Bear began. This system of 7 stars is an outsider and arrived from another Space about 6 million years ago. In the system of the 4th star there are a few planets (12), the main is **SUR**.

But the Earth had different conditions, including the atmosphere. In addition, on the Earth there was some population differing in biology. At first it was decided to silence and then to completely subjugate the Brain of the Earth (Complexes) to the Control System of the intruders and to transplant the Brain of spiders in people (in biological structure). ***Here the problems sprang up.***

The principal task of the interventional Control System (CS) was not only to bring the finished system of planets home (Sur is from the Great Bear), but also to **ADAPT** themselves **to the PEOPLE** of the Earth (while keeping their own Brain).

The earth is the border of direct control that is why Venus and Mercury have no satellites. Their complexes are completely switched off, and from the point of view of the control they are of no danger. The Earth is the center of the Control System (and before the capture it was the Center of the Universe); all the other planets have their own Control Systems, part of which is switched on. It was impossible to destroy them since their structure was unknown to EBRs Control System, that is why they were surrounded with satellites, some of which had control functions. 15 satellites (yellow color) had tubes with reference to the Earth, the rest of the satellites were tied up with reference to one of the 15 satellites.

Each satellite is either the archive or storage of tritium, spare parts and so on. 15 main and 18 intermediate (painted over) had their own UFOs, which could only move in the limits of the satellite. The satellite orbits were chosen in such a way as to have maximum control of the corresponding planet.

Of particular interest is the Moon. This is a Software Generator (up to 88 octave). Inside the Moon there are powerful complexes. The glow

of the Moon is an imposing radiation of their own systems with 128 of the octave, set by the Sun.

The Software Generator used:

- the colliders of the Earth, beat interval combined with 128 of the octave;
- created gratings on the Earth;
- Meton calendar and metric system units of "Hulk";
- data archives of the satellites obtained by the complex 555 (Earth);
- control data to correct the Program.

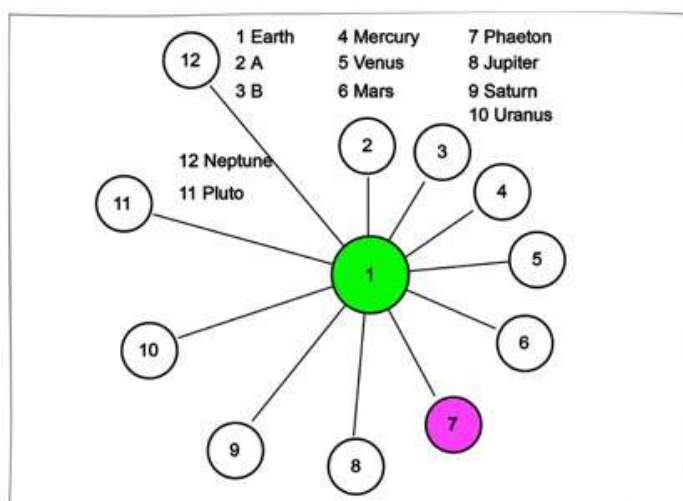

Time control and synchronization were performed by Stonehenge complex according to the data obtained from the Moon.

The moon has a special status that is why not a single meteorite from the meteorite belt does not fall on the Moon – the Moon objects (UFO's) control everything, in case of danger the Moon changes the density of gravitational potentials in the tube with reference to the Earth. Of particular interest is the **HALO** of the Moon (from Greek. ἅλως – circle, disc, aura, halo) the luminous ring around a source of light – maximum switching on of all Moon complexes and discharge to the Earth next portion of the programs. So all this talk that "**someone has been on the Moon**" – is not justified. The Man **HAS NOT BEEN on the Moon**, and he **CANNOT BE** in his physical form.

Each Program was calculated by Meton cycles – the 500 – year-program for 28 cycles and a 100-year program (from 1888 to 2000) – 6 cycles, 20-year program (1992 to 2011) – 1 cycle (final).

In connection with the correction of the Programs, there was a need for urgent replacement of the Power Supply Systems and Information SUPPLY systems on the Earth (objects 560).

The old objects were immediately removed; new ones were ready to start. Their location is known. **The start of new gratings in the atmosphere from h>-1240 and up to h=12400 m was to be produced in 2012 – it did NOT WORK.** (I'm a little ahead of time).

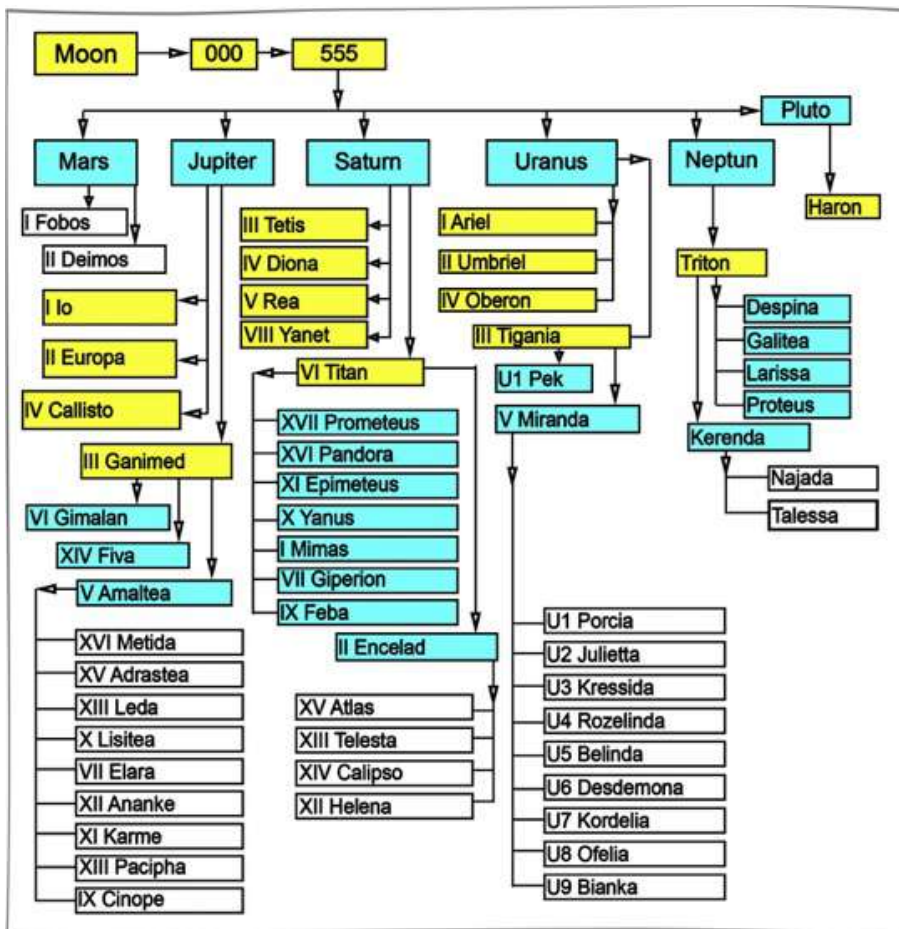

On the Earth there are other Complexes, for example, in the South East Asia. They were **NOT DESTROYED**; they have been used for their designated purpose.

The first Complex, which started to work, was **Ararat**.

After the formation of the grating with the carrier frequency the grating of "hearing" ("**in the Beginning was the word...**") was created; then in step-by-step manner the rest of the gratings were created. Specific frequency is created by a pyramid; it cannot be created with any modern equipment on

the Earth. As new Complexes were put into operation the **entire 12 groups** were created, each group having in its structure hundreds of thousands of frequencies.

Characteristics of frequency ranges

N	Frequency, HHz Range		
1	0,124	0,666	Carrier frequency k-structures ,used for everything.
2	0,666	2,16	Used by all animals, insects and majority of the population
3	2,16	4,28	Outer hearing 42x, 441 (33%)
4	4,28	7,24	Outer hearing 441 (66%), 442. For 442 information exchange with humanoids 442
5	7,24	12,4	Connection 442 with Alps 2
6	12,4	16,2	Used only by objects 440
7	16,2	22,4	Used only by complexes 560, 520, 500
8	22,4	28,8	Used only by object 960
9	28,8	33,2	Used only by object 960
10	33,2	66,2	Used by all complexes for interchange
11	66,2	88,4	Used for connection with the Moon
12	88,4	124,8	Connection with satellites

1.5. Phaeton Catastrophe

The Control System belonging to EBRs, constantly formed the sequence of events leading to the absolute seizure of the entire System of planets. However, there is one "but" –when attacking the System of planets, **2/3 of the guests** were eliminated, the planet (let's call it Phaeton) blew itself up together with the invaders.

At the initial stage of the interventional capture **18344 BC** only Phaeton was able to go into action with the aliens, as the planet, with its endowed protective functions for the entire Cluster System. The attackers forces in general terms were: **54 satellites, 3 Moons, the planet Sun** (it was a planet then), **12 leading objects (type 960) and 3862 attacking objects** (which had technical means of destruction, most of which are objects of type 440⁹). In addition, 1/3 of the satellites had their planetary objects of the active technical affect in the modeling scope of their satellites with limited autonomy (for simplified and traditional understanding – as if UFOs). The Phaeton Defenders took the whole active process of the

⁹ UFO is the facilities for the control of the outer environment (sonde type). All the UFOs on the Earth are at -3300 > h > -4400 meters. The bigger part of UFOs is exactly under populated areas. ALL UFOs are near the water expansions where at the depth of 4400 meters there are sufficient reserves of tritium. Tritium is needed only for UFOs movement within the limits of the Earth.

destructive effects of the aliens on themselves and blew themselves up as a planet-fortress to prevent its "captivity", and, especially, to exclude the penetration into its technical ability of the protective and destructive nature. Phaeton destroyed 2 Moons, 11 principal objects and about 1200 offline attacks. Fragments of that destruction sometimes disturb the Earth's Atmosphere to this day.

Now this planet's orbit is a meteor belt. The Guests were unable to destroy the Brain of the Earth (The Earth Control System), as it was above their resources, even though it had no technical means. The rest of EBRS **SEIZED the EARTH** and other planets. The rest of the space fleet of the aliens became the satellites of these planets.

1.6. Restructuring (for themselves)

19304 years ago, the invaders started and realized the following:

- captured all the planets, made a clean sweep of all the flesh and their souls (non-inertial energy substances) captured;
- gripped the celestial system of the planet Earth utterly
- the planets of the Earth system were surrounded with satellites, as "an escort";
- began movement in the direction of the constellation of the Big Dipper (URSA major).

The first aggressive invasions for 1040 years resulted in the full capture of all the planets (the end of the grip in **17 914 BC**). **The capture, by itself, was symbolic**, because all the principal complexes on the planets of the interplanetary Cluster Complex of the Earth had been **TURNED OFF** before the seizure, and without knowledge of the structures of their construction, and assuming a lower level of their cognition, the attackers just tied all the planets with the gravitational tubes (hereinafter communication tubes¹⁰). They included the embedded base generating frequency of radiation protection of the Sun, surrounded the planets with "satellites" (as security convoy) and began moving in the direction of the Big Dipper, in order to

¹⁰ Connection tubes are sleeves like Shukhov's Tower where there is a necessary set of frequencies: gravitational and informational. Magnetic impulses that sometimes come from the Sun move to the Earth only in the sleeve. If there are no supporting frequencies in the sleeve magnetic impulses are dispersed in the Space (do not reach the Earth).

make it clear the area of its active reach. But on the way of the movement it was decided not to waste time and carry out some possible change in their favor...

A. Khatybov proved that the World around us **IS NOT SOMETHING** material separate and ideal separate – **is a united and indivisible whole**. Just this world is expressed in different sets of frequencies. This is the only difference. But through the perception Man was imposed the *illusion of the would being only material* and **SEPARATED** this **WORLD** from its mental and spiritual activity. Earlier, before the invasion, there had been no such perception of the world (via duality) in our Ancestors. *We can't call our Ancestors people or Human beings because modern Man in comparison with our Intelligent Ancestor is a Monkey compared to Man*, as paradoxical as it may sound. And "lowering" our Intelligent Ancestor to the level of a "modern" Man **WAS** made by external Forces. That explains the weird development of the entire Earth's history, with its countless wars and immeasurable violence, and strange evolution of science, which actually *enslaved the Mankind*. In what way and who all this was and is being carried out– we are going to make it clear in a serious way in this book.

Let us leave this trial "for a while". Meanwhile, let's take a closer look at what could have been the Creation of the Higher **Mind** of our petal-universe. Again have a look at the heritage of our ancestors-the Slavs – the Slavic-Aryan Vedas.

"In the ancient and glorious times in the land of abundance of Midgard-Earth, in a fertile ancient region, in the ancient and mighty Asia, which lay to the East of the Repeiskiy mountains (the Urals) and extended beyond the H'Aryan Sea, and from the chilly sea of D'Aryan to the greatest Himavat mountains lived four great Kins of Aces, the descendants of the ancient gods of Light, the four great families of Rousichi.

The great and most wise of Asa began to move into Asia from the **Sacred Land of Daaria**¹¹ in the ancient and glorious times.

¹¹ Daaria Land was situated on the Continent that sunk in the Arctic Ocean.

And **Families began to live** happily in this blessed ancient land from the beginning of time of prosperity, when even our **Great Forefathers** beheld **three moons**¹² in the night sky .

Ancient and wise, the Great Aces called this fertile region the Holy country, the country of kin's of Asa or the land of the Holy Race.

Multiple families of the wise Aces came into this fertile region of Asia from the Sacred North Land where our **Three-Light-Yarilo-Sun**¹³ **will not want to have a rest**, if only to witness the benevolent acts of all Light Heavenly Gods and the creations of their great descendants in the fertile Midgard-Earth."

Let us see some other sources of information to have a more complete picture of the chronological events on our planet.



Some of the extant ancient myths and Chronicles say that "the Earth existed, **when there was no moon in the sky above her**". Greek philosopher and astronomer Anaxagoras of Klazomen wrote about this in the 5th century BC who made use of the ancient sources, which did not come down to us and which claimed that the Moon appeared in the sky later than the Earth origin. In the III century BC it was supported by the Greek philosopher and poet, General attendant of the library of Alexandria, Apollonius of Rhodes.

In the essay "Argonavtika" he quotes the words of another philosopher, Aristotle, a century earlier, mentioning in one of his writings about the ancient inhabitants of the mountain districts of Arcadia (region of

¹² Three Moons: – 1) Lela, revolution period around Midgard –Earth (the planet of Earth) was 7 days; 2) Fatta, revolution period around the Earth was 13 days; 3) Month, revolution period round the Earth – 29,5 days.

¹³ Three- Light Yarilo-the Sun –An Ancient Ancestral Wisdom runs that the original Sun was called Three-Light as it lit three worlds: Yav (the world of living); Nav (the world of the dead; Slav – the world of the Gods.

Peloponnese), who "fed on acorns, **and this was in the days when in the sky there was no moon** Three Moons of Midgard- Earth. Writer and historian Plutarch, who lived at the turn of I-II centuries BC, says about one of the rulers of Arcadia named Proselenos, which means "Before Moon", about his subjects proselenitas, the first inhabitants of Arcadia. Modern scientists do not deny the possibility of the "**moonless**" stage in the history of the mankind and give different explanations. According to one of them, once **the Moon was one of the planets of the Solar system**, but then, because of some cosmic catastrophe, **left its orbit and became a satellite of our planet.**

You can draw a slightly different picture, **WITHOUT REPEATING** the interpretation of the publishers in the footnotes of the text of the Slavonic-Aryan Vedas and referring to earlier documentary sources. Our ancestors gave the name of moon to the satellites of planets. Since our planetary system was **CREATED ARTIFICIALLY**, everything was conceived and manifested in its unique structure in relation to many other planetary or solar systems of natural origin.

Certainty about the uniqueness of our solar system have appeared recently, when it became possible to explore open "exoplanets" (planets orbiting other stars) and discover that in other solar systems everything is not like in ours. Recently, on the subject, there was a small article under the name "**Solar system was born in a unique environment.**" "American and Canadian scientists using computer simulation proved that for the formation of the Solar system there were unique requirements, and it is a very special case among other planetary systems. The study is published in the journal "Science". Most of the previous theoretical models explaining the formation of the Solar system from a protoplanetary gaseous-dust disk were based on the assumption that our system is "average" in all respects. In recent decades it was discovered about 300 exo-planets – planets orbiting other stars. Summarizing these data, astronomers from the American Northwestern University (Illinois) and the Canadian University of Guelph, came to the conclusion that the Solar system is in many ways **a UNIQUE CASE**, and that its formation required a very special conditions."

One major change on the Earth was switch-over of the underlying basis for the formation of spaces **with dodecahedral to cubic basis** of the formation energy gratings. The imposed cubic¹⁴ energy grating, having

¹⁴ In the process of creating the Earth there was a working structure of another grating inside the cube, and cubical was used only for the control. More than 5000 years ago a certain system changed the

framed all previous state and energy structures, changed and restricted the status of the material world on the Earth to a level acceptable only for the strange Control Systems, changed all the conditions of the environment, including the atmosphere, water, biosphere, etc. Nowadays this process is **HAPPENING Vice VERSA**. The base of the space formation is shifting **from cubic to dodecahedral** basis of the formation of energy gratings. This has been considered in the creation of “Svetl” Programs as well. But there, this whole "procedure" is carried out through the design of Tor, as a kind of "Converter» of one design to another (without destroying it). About this – later.

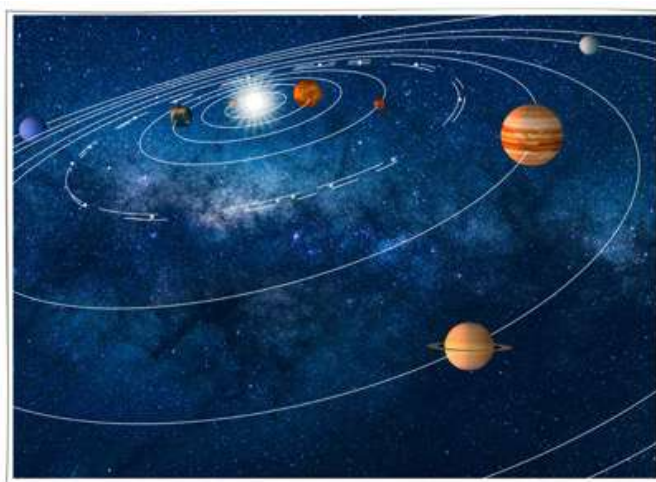

The satellites of our Planets played a special function – the protection function and the reflection function of our atmosphere albedo, which on the one hand, created the stability for the Planet and life on it, reducing the risk of getting random space objects by creating a **gravitational-electromagnetic oasis**. And on the other hand, **CONTROLLED** the **HEATERING** of the planet's atmosphere. This allowed the system of the light paraphase (our **Three Lights-Yarilo Sun**) evenly distribute the heat across the surface of the planet, creating the necessary conditions for the abundance of the vegetable kingdom – the Foundation of all life. Permanent vegetable photosynthesis gave the required amount of oxygen, such a valuable component of the gaseous environment of the Planet, both for the purpose of creating a robust ozone shield, and the saturation and evolution of the intelligent beings Brain for its **BETTER FUNCTIONING**. As it is

connection relations, and inputting its own elements, created a new type of grating, in which the whole world has been existing since. Its depth is 2200 m, height =12400 m. That is Noosphere or the world of environment and inhabitat.

known, lack of oxygen leads to the degradation of the physical cells of the Brain and reducing the lifespan.

The paraphase¹⁵ of the light is a shift at a certain value of the light pulse phase. For example, **at zero bias**, we have normal sunlight, **at 120° bias – night, at 240° bias** – the transition of night to day, or daybreak. This cycle is repeated daily, and no one ever doubted that **EXACTLY** the **SUN** is the source of light. In normal life **Man is protected**, which weakens the light beam at about 1000 times, and when Man is gone (dies), this protection is removed, and the sunlight becomes unbearably bright and the only source of heat, and that's why nobody wants to leave it. If Man dies at night, then the intensification is in the opposite direction, here the dying man tries to fight for his life, as he falls into the cold darkness.

This protection can be observed indirectly in the form of the refractive index of the space's boundaries of the protective field around one person or total fields of a group of people. Rainbow color indicates **SPACE DEFORMATION** produced by the seven forms of the primary matter.



Modern physics teaches that the solar light is both quantum (material particle) and a wave at the same time. If is an elementary particle, it is in the line with the other particles arriving from outer Space (**but nothing arrives from the Space, apart from the crumbled dust of the outer shell of the motion cone of the Solar system, and the incoming trash has the same structure as on the Earth**). There is no other

¹⁵ Paraphase is both the Brain function and simultaneously external conditions, e.g. sudden appearance and disappearance of the source of light in the determined phase.

information about the sunlight. But P. N. Lebedev's experiments on the pressure, produced by a quantum of light are known. However, the Sun is the principal information complex, producing the supply of necessary information to **all 12 levels** which are divided into frequencies.

The structure of quantum of light is "an egg".

At a certain phase of the atmosphere the required frequency information was given to someone more, and to others – less. There were regulations of the length of day and night, heat and cold. During these paraphrasing one program was removed and another program was delivered. Let me remind you that the ultimate supplier of the Program was the Moon. The external symptoms of the intake of the required octaves were manifested in the form of the Northern Lights, which no longer happen due to frequency changes in the Earth Control System.



Similar but the reverse of this process are visible in the appearance of vertical color columns at night and in frosty time of the year. Here the process of pumping the atmosphere from the earth takes place.

In this regard, we can conclude: when the frequency characteristics of the Earth Control System are changed the alternation of day and night is necessary.



But was it always necessary?

Is the alteration of day and night necessary for already-developed Intelligent Civilization? Had it been thought over another lighting system to accompany this unique experiment?

1.7. A little about the Sun

I got carried away a little, but (objectively) I specially touched upon these issues, just to show you a logical "Interrelation" and confirmation of the information from A. Khatybov and N. Levashov. And this (I hope you have already comprehended) – is an **OBJECTIVE PROCESS**.

As I have already mentioned, our **Svetilo (Jarilo)** had been **TURNED OFF** and **REPLACED** for **the Sun**. All the Planets were "located" with reference to the Sun with the help of the preformed connection tubes. The usual people's perception of the material world does not make it possible at first to take the word "turned off". There comes an association that something wrong had happened to the Sun. Had it exploded? Had it turned into a neutron star? Had it been stolen and swallowed by a crocodile, as in K.I. Chukovsky's poem? If it had been an explosion, the entire Planetary system would have perished. The transformation into a neutron star does **NOT HAPPEN fast**, and the gravitational forces of such a massive body just would have ripped the atmosphere off all the Planets. Even the notorious approach of **Planet X in**

2003 threatened the entire Solar system. There is one last option: ***the true system of the world, which is created by the atmosphere grating at the phase of light pulse at 0 was called Svetilo (Luminary)***. The paraphase speed is affected by the light parameters, color spectrum, brightness, flow density, the planet's code (for the Earth it is 512) and the distance from the sun. The octaves of the Original ECS were lowered, and since many principal systems of the Earth were captured by the invaders – they **HAD TO BE TURNED OFF**.

In search of a more complete understanding you can refer to another important source of information – **the book by N. Levashov "The Tale of the Light Falcon" – the past and the present"**.

"...our distant and not so distant ancestors called our luminary **RA** or **YARILO-the SUN!** In the same way our planet was called **MIDGARD-EARTH** and not just EARTH as we call it today! Because **MIDGARD** is the **WORLD** inhabited by **PEOPLE**. So for our ancestors ***the word "Sun" was not the name of our present Sun***, as well as "Earth" was not the name of our planet! Every planet, every star in those days had their own names, including the planet-earths and their suns which were distant for many light years. All the **LUMINARIES** and **PLANETS-EARTHS** had names that these celestial bodies were given not by our ancestors, but the inhabitants of those planets from distant constellations from which immigrants populated our planet Midgard-Earth in stages!" BY the time of capture, ***the world population had been 1.4 – 1.2 billion proto-Humans***.

This **IMPORTANT** and **KEY** information on the replacement of our Yarila (True Earthly light – White Light) for the Sun was first given openly in an interview with the candidate of historical Sciences, ethnologist, art historian, member of the "Russian Geographical Society" **Zharnikova Svetlana**



Vasilievna at the 2nd Vedic Congress in 2010. Unfortunately, Svetlana was gone in November 2015...

From **the writings of N. Levashov** it is known that for the emergence of life on the Planet, the following conditions are to be observed:

- the availability of constant differential dimension;

- the availability of water;
- the availability of the atmosphere;
- the availability of an alteration of day and night;
- the availability of atmospheric electricity.

This is true **for the origin and evolution of Life from the Beginning**. I emphasize, from the **BEGINNING** Without outside influence these processes take a lot of billions of years. Often Life has no time to develop up to Reasonable on one or another planet, not being provided with additional stability and protection – life support on the part of the Control System.

In the natural conditions planets are formed in the zone of the warped space at "the explosion" of the Super New Star. "In the process of the star compression the balance is upset between the radiating surface and the radiating volume. As a result, the primary matter is accumulated inside the star.

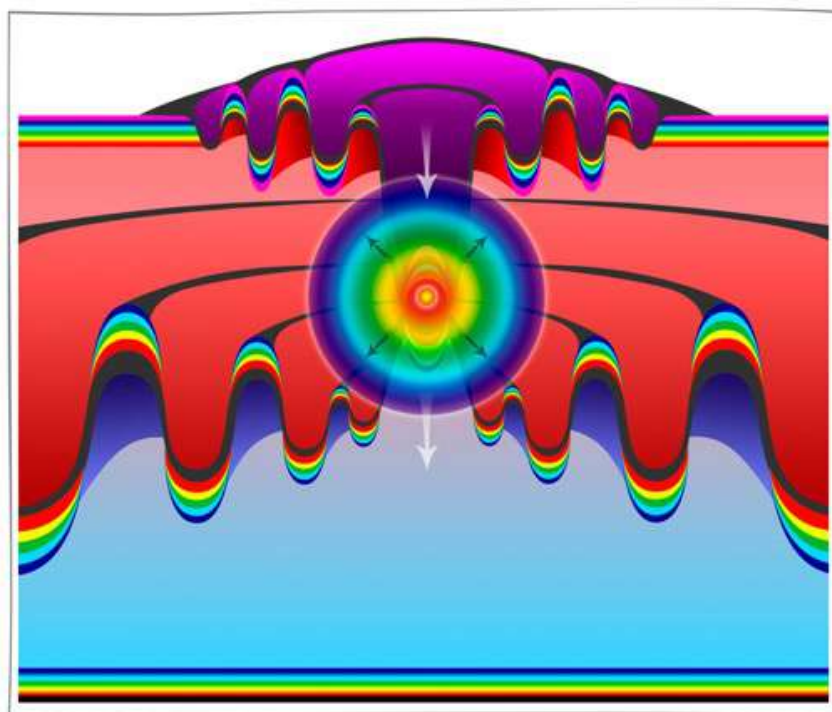

In the course of time, as a result of thermonuclear reactions, the star substance loses the simplest atoms such as hydrogen, helium, etc., and atoms of the heavier elements begin to account for a higher percent. **The size of the Star decreases**, it becomes more and more dense, heavy, and the degree of influence on the dimension of the surrounding space becomes

more and more powerful." The released matter of the star and Primary Matter are able to form a Planet of suitable size at a suitable distance from the source of deformation. All the Planets formed as a result of the Super New Star explosion settle down the planetary system not only in the Ecliptic plane, which is impossible to find in the Macro-Space, as it is unusual in its nature, but in harmony with the structure of the inhomogeneous space... According to materialistic views, the instrument observations, derived data and using computer models of stellar evolution "*the Sun will exist for another 5 billion years, **gradually heating and increasing in size.** When all the hydrogen in the Central core will be consumed, the Sun will be 3 times more than now. Finally, the Sun will cool, becoming a white dwarf.*" These are the conclusions of "modern scientists". However, I dare to disappoint them – it is not necessary to wait 5 billion years. Everything will happen (and already is happening) absolutely **NOT THAT WAY.**

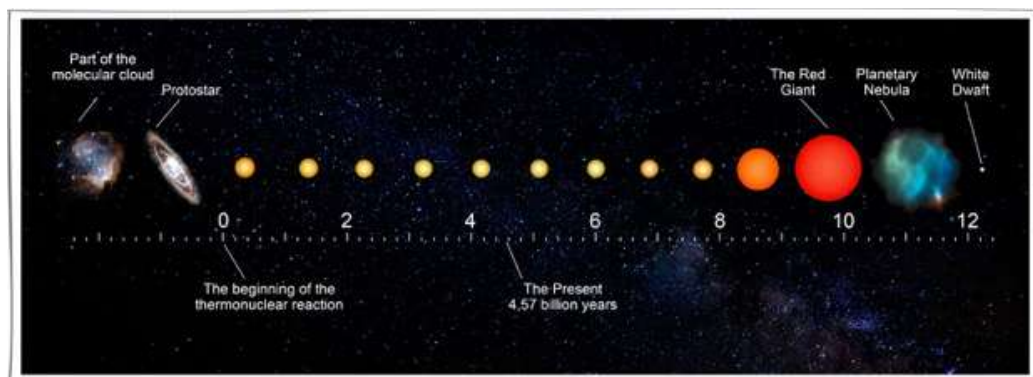

As you can see from the two descriptions of the evolution of the Sun N. Levashov's, and A. Khatybov's views and of modern science are **QUITE DIFFERENT**. We can assume that one of the sides is wrong. However, let's not jump to conclusions. **Nicolai Levashov in "Inhomogeneity of the Universe"** showed the process of matter formation and explained the birth of stars, their evolution and the formation of black holes or neutron stars. Astrophysics observe the particular Sun, and the observations show that the growth of the atmosphere of exactly our "star". But if the mass of the star compresses, according to the laws of gravitation no planetary nebula can be formed. There's something not consistent with the nature of the star itself. What could cause this anomaly? I will repeat myself in something, and draw your attention to the description of the Sun by **A. Khatybov.**

The sun is the planet that was "driven" into our System (with the Moon), the diameter of the Sun is approximately equal to the diameter of the Earth. It had the atmosphere thickness of about 2000 km, consisting of a

mixture of oxygen and chlorine. The sun is hollow inside, there is life only inside (as in the shell). There is everything necessary to support the life that the aliens wanted to create all over our System. In addition, it was necessary to replenish stocks, which there were on the satellites before the attack

Due to the abstraction of energy from the Earth a new atmosphere of the Sun has increased in size more than 100 times (the diameter is 1392000 km).

Current approximate structure of the Sun atmosphere

№		Layer thickness
1	Mixture of hydrogen and helium, t^0 about 3000 0	19200 km
2	Grating Frequency 53,375, potentials density 127,4, body 111	332000 km
3	Grating Frequency 53,875875, density 121 and 100	128000 km
4	Grating frequencies of oxygen and chlorine, density 100 and 100	63000 km
5	Grating of protection 49 octave, density 100 and 100	146000 km
6	Hydrogen grating, octave 36,5, density 75 and 75	2000 km

The Sun has the frequency Converter. Receiving energy at **49 of the octave**, they transform it into 53,375, supporting radiation grating. The surface temperature of the Sun does **NOT EXCEED** 20 C. 49 octave was pumped out of the Earth (the Polar Lights) by means of special objects on the Earth.

The sun is a gravito-magneto-electric Generator of the motion of the entire Solar system. The sun is the beat Generator of the motion and this Generator is interfaced with the Life Support Systems of each planet. And there is no need to listen to the professor of the Hydro-Meteo-Centre, informing us that the cyclone (anticyclone) brought the temperature. This is a **LOCAL CHANGE** in the electrical parameters of Hartman frequency spectrum resulted in the macrostructures movement (the atmosphere). But back to the sequence of events.

1.8. The takeover of the planet of the Earth

18300 years ago the takeover of the planet of the Earth was carried out by the forces of the remaining Star fleet of the invaders. All the structures of the life support of the planet's Brain were annihilated, and it lost its potentials to the level of 3%, which further resulted in the elimination of all the inhabitants of the Earth in the short period.

At the same time, the following events occurred:

- the annihilation of the true Complexes of the Earth Control located on the surface;
- formation of the areas of paradise for the invaders' existence;
- annihilation of the life Support System on Mars;
- turn off the life support system of the other planets;
- formation of the system of satellites around the planets;
- the beginning of the structure transforming the captured planets.

The Earth Brain prior the **ATTACK** had had the **512 octave**. The planets-invaders' **Brain** was of the **224 octave**. Subsequently, for a number of reasons of incompatibility under the new conditions of the Earth, this invaders' Brain up to the 66 octave **WAS ANNIHILATED**. The remaining structures of the Earth managed to keep the Brain of the 57 octave for a short time (mainly in the Equatorial area). With the further reduction of its level, the population decreased by 67-68%, and there were only **about 2 million people** with their subsequent dying out.

The Easter complex as one of the true main complexes of the escort (located under Easter island at $h=-12450$ m) was completely off. After a series of the Program processes on the part of the interventionists ***Man was transformed into a kind of biological being, deprived of the former independence of the Brain.*** This is the foundational information that makes it possible to understand all that happened afterwards, up to the present day.

What is this program link with the Sun, the moon and the planets satellites like? What part did it play in the overall evolution processes of the human Civilization and conscious evolution of an individual and public, in particular?

Technically, this link looked like **a SPECIFIC SET** of the **FORMED** "Link Tubes" with the Earth, on the one hand, and the Moon, the Sun and the planets Satellites on the other hand. By means of such link tubes it was carried out the transfer of information from the invaders' generating and Control systems ***placed beyond the Earth, to the complexes of the same Control System, placed on the Earth.*** This program information contained everything required for the control the entire imposed development of Civilization at a conceptual level.

First and foremost, it is through this connection it was ordained the **FORCED RETENTION** of the people's performing actions in their applications in the same way as consumer goods in all the program processes controlled by the interventional System, and, accordingly, step by step

preventive development of an individual and public conscious before every historic eventful executive step. Using the same information, the Conceptual level Control of all the processes of energy being in general in their changed structural state was executed. Monitoring and protection was formed to prevent any structural changes in the energy gratings by the true Earth complexes, the retention of such complexes in "captive" state and so on.

The Earth was populated with people that were differed in biology. Therefore, the decision was made **to ANNIHILATE the EARTH BRAIN and transplant the Brain of spiders into people (their biological structure).**

Since that time, especially in the last **4000 years**, the **interventional Super-system**¹⁶ using the changed System of the surrounding structures have conducted a great deal of process monitoring (including all life-support Systems, the Earth Biocenters that create and support the Man) and **DIRECTLY the MAN HIMSELF.**

For these purposes, the invaders put into operation the Program of **"Energybiogenesis of the flesh cells,"** which was becoming more substantial in the reinforced attempts to create people (like a kind of proto-Human), for the spiders' **FLESH** (which were the invaders) was **IMPERFECT** and unacceptable to get "the entrance to the Hierarchy of Civilizational evolution of the Intelligible orientation" (as, however, and the design of their Brain, too). This was ultimately one of the reasons for the **TERMINATION of THIS KIND of EXPERIMENT** and **the beginning the process of returning to the starting "point"**, what is actually happening today before our eyes. Who realizes it and how it is realized is of less importance. Of primary importance is what is happening, and no one and nothing are able to stop the process.

1.9. Available Means

If You are left in a boat in the middle of the ocean, You **WILL NOT** study the structure of the boat and the method of fixation the frames. First and foremost, using all available means, you will try to determine your whereabouts and then sail in the direction you got to know. Exactly so did

¹⁶ Interventionist- super system -is the Program connection with the Sun, the Moon and planets satellites.

those who arrived in the Earth several thousand years ago. First, the coordinates were defined, the "milestones" were set and the conditions created to move the entire System (like JOHN Swift's Gulliver, who dragged the ships) in the **RIGHT DIRECTION**.

A special place in the "ancients" studies belongs to **the Big Dipper**, which is described in detail by **N. Morozov** in his multivolume work "**the Christ**." In addition, on the Earth it was built (there is no clear answer what for) quite a lot of pyramids, and in the process of more exact definition of their coordinates, many of them became unnecessary (the pyramids of Maya, the pyramids in Ecuador, etc.).

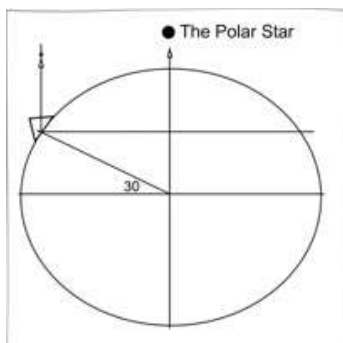

The calculations show that the pyramids were set up as a **SYSTEM** of **CONTROL** on the ways of the Power Lines of the Earth's Complexes. The Ecuador pyramids' ramps pointed to Benethash star of the Great Bear. All the pyramids were built not on a randomly selected place and, of course, the calculations were made not on the sand. The calculation accuracy of some constants is **up to 124 signs** (determined by indirect calculations, when the ratio of dimensions lead to a constant) **AFTER** the **DECIMAL** point.

So **the first conclusion**. Upon arrival in the Earth, that had already had its own civilization, **Ebrs** (aliens, after N. Morozov) first marked their location by doing layout work and putting stakes, besides using the UFO's computer system.

How the Solar System was deployed and where it is moving today is a separate issue? Let us consider one of the most important systems of the control – **Cheops Pyramid**.

Many Scientific works (as to pyramids in general) were devoted to Cheops pyramid, and all of them stated the existence of the pyramids, piling theory of their construction, as well as derive practical results by dragging the mummies from pyramids to museums.

Many deaths of the pyramid researchers are ascribed to the "curse of the pharaohs" of those who disturbed their peace. We see only the **IONIC PART** of the **COMPLEX**; to explore non-inertia mass of the pyramids the Humankind has **NOT** yet **DEVELOPED** the instrumental base. Here are **A. Khatybov's** calculations, only a small part of which has become public today.

The Pyramid of Cheops

Looking ahead, I would note that the Pyramid of Cheops is located on the territory with coordinates **30° N.L.** and **30° E.L.** and the north side of the pyramid facing North, precision 2'.

The first pyramid with the inclination of **52°** and the entrance angle of **28°**, where the North Star was visible was the pyramid near Medum. It is destroyed (It is thought – by an earthquake). Its dimensions were smaller than of the later Cheops.

The desire to keep the **angle of 52°** and the slope of the entrance with visual surveillance of the North star is not accidental. Besides, the correlations of some values indicate the angle of inclination of the pyramid side.

Let us make a circle with radius $R=h$, i.e. equal to the pyramid height (h).

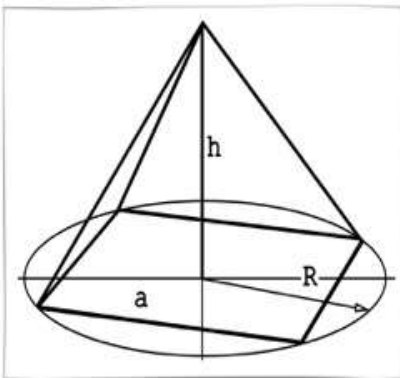

correlation:

$h=146,75$ m;

$a=230,62$ m;

$R=146,75$ m;

$$\frac{\pi * R^2}{a^2} = tg(51,84^0)$$

The second conclusion.

During the construction of pyramids, the used system of physical units remained secret. Translations into the existing measurement system do not give any idea about the meaning and purpose of pyramids.

Some of the correlation values in Cheops pyramid point to the existence of a hidden (maybe, the main) pyramid, the exploration of which with modern technical means is impossible.

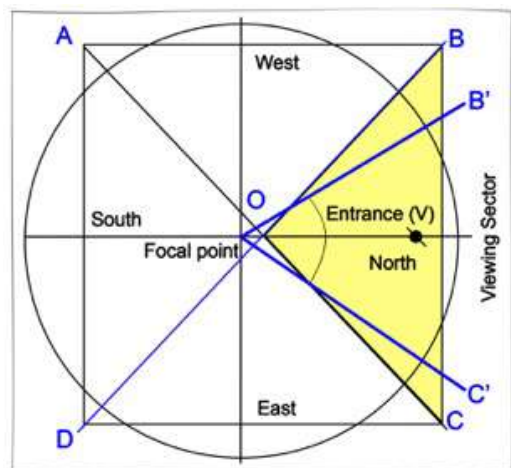

Let us consider Cheops pyramid from the point of view of the Control System (Cheops pyramid is the control data transmitter for the Earth Motion Control System and for the Solar System).

Index SU FS and SS=555 (from the command texts).

Parameters of Cheops pyramids:

Side: AB=230,62 m;

Height: OG=146,75 m;

The height including the cut: SG=138,38;

Side: OA=219,38 m;

The side projection OA (AG)=163,07 m;

The plane inclination angle = $51^{\circ}84'$;

Entrance height =18 m;

Volume (without cut top): V=2601238 m³.

The contour of Cheops pyramid encloses the other Pyramid, which is the principal one.

The great pyramid has some structural features: Southeast corner is higher than the North-West by 2 cm.

The size of the entrance is **rigorously calculated** (see below).

The deviation of the sides = $3,6'$ (orientation to the parts of the world).

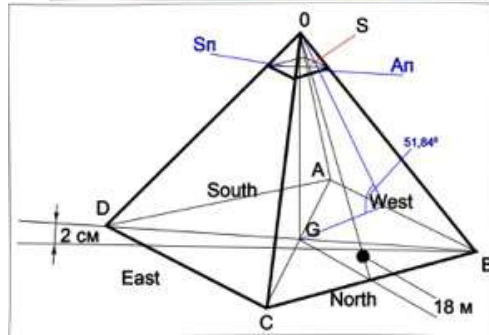

Angle AOB=63,4°=63025'

2*AB/OG=2*230,62/146,75=3,1430;

Side of the site An=13,15359 m;

Site square Sn=173,0169419885 m;

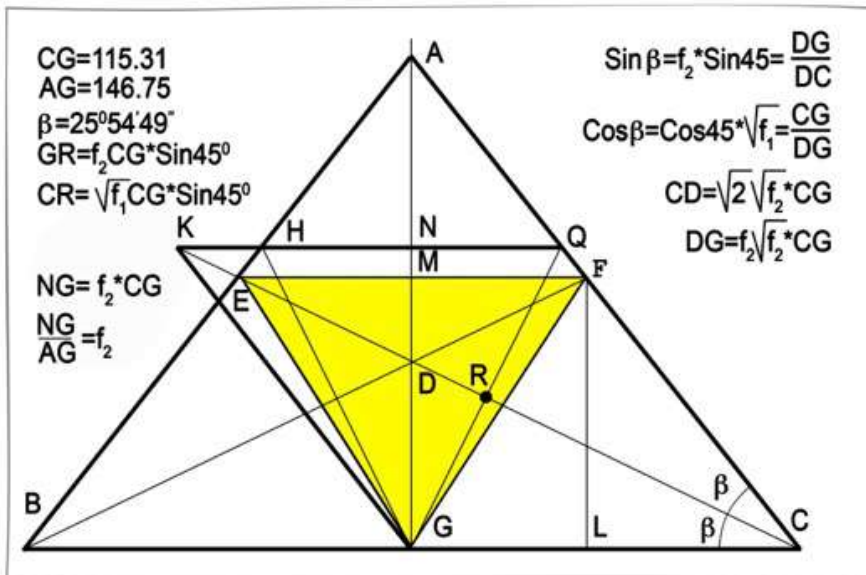

In compliance with the Golden section we have:

$$\frac{CG}{AG} = \frac{115,31}{146,75} = \sqrt{f_2}$$

Angle $\beta = \text{FCK} = \text{KCG} = 25^\circ 54' 49''$;

Angel $\text{FCG} = 2 * \beta = 51^\circ 49' 38''$;

KQCG – full rhombus.

It is the rhombus that forms the spiral of the Golden Ratio, the format of the rhombus is laid in the angle of inclination of the pyramid plane. The height of the pyramid is offset by 6° towards the South of the ratio:

AB=230,62 m	CS=71,27	MG=113,9	NG=FG = 128,82
AC=115,31 m	AS=44,04	OA=186,63	OE=128,56
OC=146,75 m	S'G=174,00	MQ=132,36	CS/AC=0,618
OP=173,05 m	FP=18,188	FM=58,00	$4 * \text{AC}/\text{OC} = 3,1430$
OF=174,00 m	EG=101,02	OM=116,00	OM/OF=0,6666..
OR=264,00 m	EE'=13,512	GA'=18,188	FR*OM=100*AB
FR=198,54 m	GE'=114,53	ON=MN=FM=58	

Point S' is diametrically opposite to the point S.

Angle $\text{BFC} = 67,5^\circ$ – viewing sector.

$\text{SIN } 6^\circ = 0,1045284$.

$\text{COS } 6^\circ = 0,9945219..$;

$\text{TG } 6^\circ = 0,1051042..$;

angle $\text{OAC} = 51,840$;

angle $\text{FOP} = 6^\circ$. the pint F – focus, the line **with reference to the Earth gravity centre.**

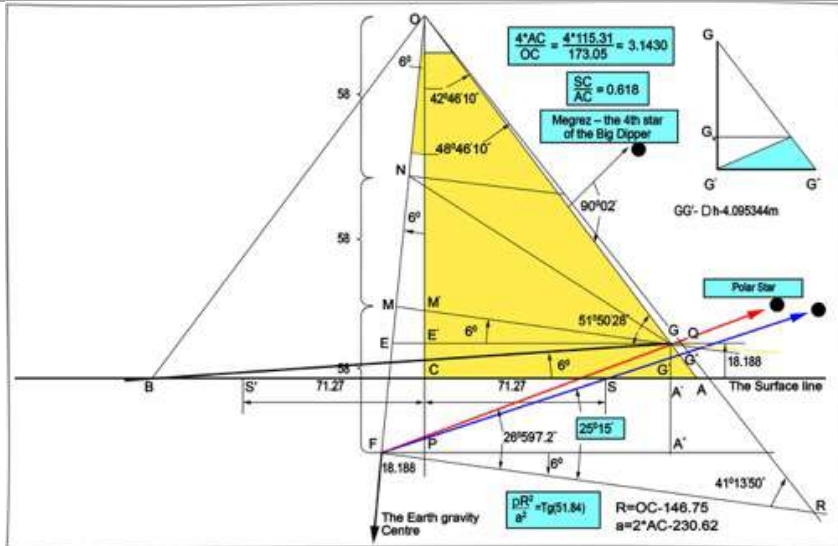

angle FRO=41.230577°;

Sin (41.230577°)=0.4537626;

angle G''FR=26°59'7.2" (26.985347°);

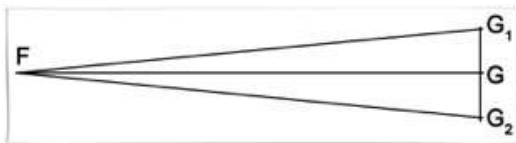

The angle FOP=6°. Point F Is the Focus, the direction of the line **to the gravitational center of the Earth.**

Угол FRO=41.230577°;

Sin (41.230577°)=0.4537626;

Угол G''FR=26°59'7.2" (26.985347°);

GF is a cone, the star comes out in the funnel at 12', G₁G₂=0,4461769 m. The line G₁G₂ is divided into 6 parts, Medrez passes one section for 144 steps of transmission, that is 2 minutes.

If the ionic grating has 32,22502250 communication structures, hidden pyramid has the grating 53,625. By the way, **EXACTLY** in this pyramid the "curse of the pharaohs" is laid – frequency radiation (gamma rays).

Angle GFR=25°15' exactly this line (or rather the angle 25°15') determines the inclination of the equator to achieve 0 albedo, and cannot be violated in connection with the complete imbalance of the Control System.

Parameters:

EG=101.01863 m;

$FA'' = 119.21$ m;

$G'a'' = 41.628819$ m, $GA'' = 45.724163$ m, $GG_v = 3.2125163$ m;

$GA'' - G'A'' = 4.095344$ m;

$Tg\ 25.25 = 0.4716306$;

$Tg\ 19.25 = 0.3492156$;

$Tg\ 20.985347 = 0.3835706$.

The sequence of passing the world pole:

π, η Hercules;

τ Hercules (VIII-VII BC);

ι Dragon (5500-3500 BC);

α Dragon (Tuban) 3500-1500 BC.

β Little Dipper. (COHAB) 1500 to 1 BC;

Cohab, and Cynosura Little Dipper. (Guards), when the world pole was between them;

α Little Dipper. (Cynosure) 1100-3300 BC;

(Guardians were announced β and γ Little Dipper) Cepheus (γ Albano) to 5000 BC (β Alfaro) to 6500 BC (α Alderamin) to 8500 BC;

Deneb, and Sandr (γ Swan) VEGA (α Lira) in 13000 BC (6th time);

Polar (α little dipper – Cynosura) will pass by the pole of the world with accuracy at $27'$ in 2100r.

Since the world pole walks about the constellations, then, together with it there occur changes in the location among the stars and of the celestial equator, and the point of the vernal equinox from which the celestial coordinates are measured.

The precession cycle of the Earth's axis is the Platonic year.

The third conclusion. The Solar System motion to Megrez star is on Archimedes spiral.

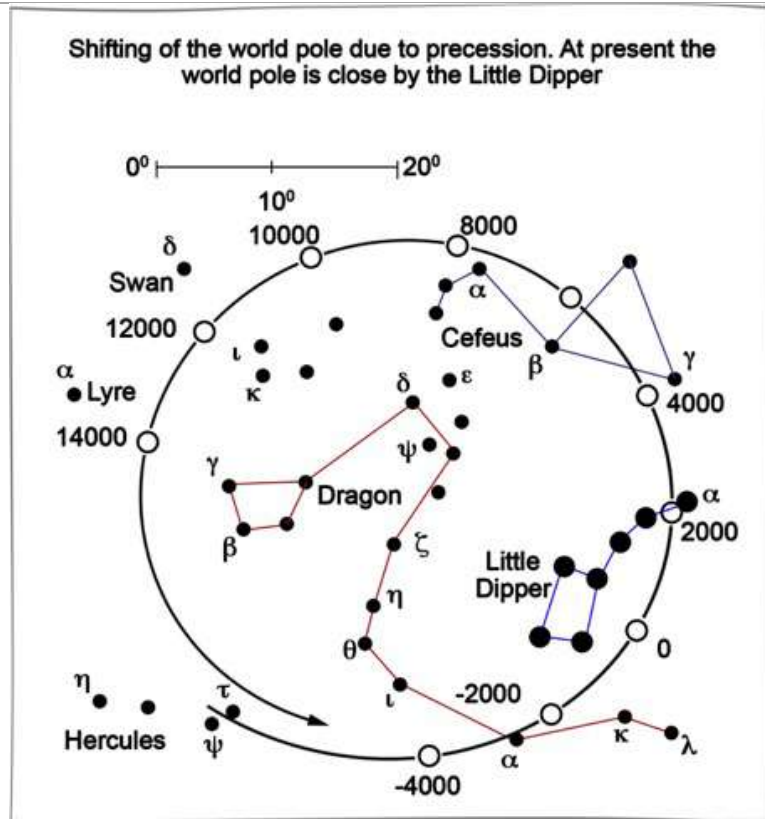

CALCULATIONS on Archimedes spiral has **ALLOWED** to find out the Ebrs arrival time in the Earth, and the uniform rotation of the world pole while moving on Archimedes spiral is incorrect.

The fourth conclusion. *Ebrs appeared on the Earth approximately 18300 years ago, annihilating the Brain of the previous civilization.*

Back to the pyramid of Cheops. First of all, some correlations:

$\beta = 23^{\circ}27' = 23.45^{\circ}$ – the equator tilt to the Ecliptic plane;

$\gamma = 5^{\circ}08'43.4'' = 5.1454^{\circ}$ – the Moon equator tilt to the Ecliptic plane;

$\alpha = 28^{\circ}35'43.4'' = 28.5954^{\circ}$ – the total angle.

For 1 year (365.26 days) the Earth passes a distance $L = 149.6 * 2 * \alpha * 106$ km = 939964520 km;

Speed $V = 29.785678$ km/sec;

$V_{\text{vert}} = 14,256062$ km/sec;

$L_{\text{vert}} = 449887100$ km.

The sum of the angles (the direction to the Polar star of the pyramid plus the inclination to the Ecliptic): $46^{\circ}54' = 46,9^{\circ}$;

The angle of inclination of the plane of the pyramid $51,84^{\circ}$;

Difference $= 4,94^{\circ} = 4^{\circ}56,4'$. The difference with the Moon $= 0,2054^{\circ} = 0^{\circ}12'19,4''$;

Distance $AB=L=939964520$ km;

Distance $AC/2=131352001$ km (the distance to the Sun, or 1 astronomical unit).

The solar system moves in a spiral. In this system the Earth moves in a double spiral (the revolution around the Sun and rotation together with the Solar system).

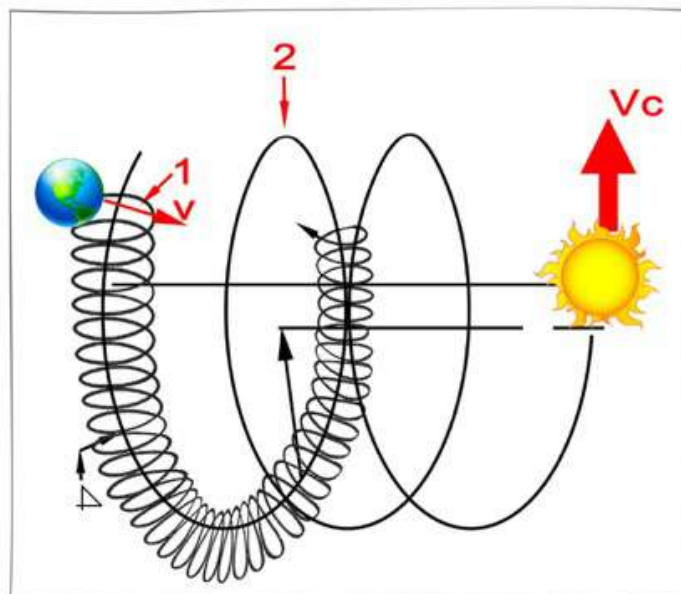

The Spiral of Archimedes

1 – The trajectory of the Earth in rotation around the Sun;

2 – The trajectory of the Sun.

According to Astronomical observations, the Solar system has been changed 5 times for the Polar star, but how and why science has not known.

The distance between the turns of the spiral $= 2 \cdot p \cdot S_{\text{vert}} / w$;

$w = 28.59540 = 28^{\circ}35'43.4'' = 0.4990838$ rad;

If we take $w = 28.647890 = 0.5$ rad, then the difference $= 0.0524897$ rad $= 3^{\circ}8.96''$

The accuracy of the orientation of the compass at the pyramid of Cheops = $3.6' = 3'36''$.

For the precise orientation it is **NECESSARY** to change the angle of inclination to the Ecliptic that is why the second (hidden) pyramid is needed. This pyramid is with the floating geometry (up to the 54 octave). If the angle is constant, we have the logarithmic spiral.

Some oddities

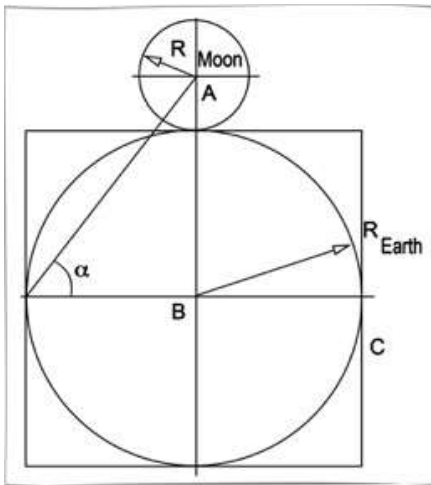

The Earth Radius $R=6378$ km;
 The Moon Radius $R=1738$ km;
 $R_{Earth}+R_{Moon}=AB=8116$ km;

$$\alpha = \arctg\left(\frac{8116}{6378}\right) \approx 51,50267^{\circ}$$

Inclination angle of the pyramid plane = 51.5040 ; $4 * C = 8 * R = 51024$ km;

$P = 2 * 8116 * \pi = 50994.331953..$;

The difference = 29.7 (within the limits of the calculations error) Ratio of the surface square (round the Earth) to circle square with radius AB $D=0.78631...$, и $\text{Arc sin}(D)=51.840$.

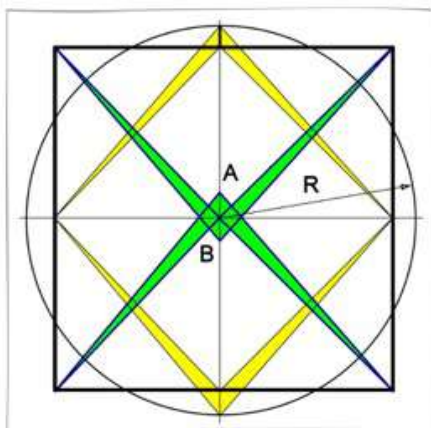

Mason Cross (a pair of compasses).

Circle and square perimeters are equal.

$R=f_2 = 1.618...$ $C=2 * R * \pi = 10.1664...$

Square side $a = \frac{2 * R * \pi}{4} = \frac{R * \pi}{2}$

$a = 2.5416017...$ (Inch);

$\frac{a}{2} = 1.2708..$ $AB = 0.6944678$.

Inch is obtained from the problem «circle quadrature».

$\frac{a}{R} = 0,7850258..$ $\alpha = \arcsin\left(\frac{a}{R}\right) = 51,757927..$

Roughly CHEOPS pyramid angle. Calculation accuracy might be any. Inch value does not depend on the quantity.

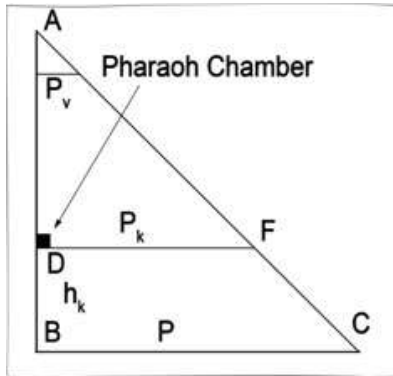

$$\frac{P_K}{P_V} = 6,1988$$

$$\frac{P_K}{h} = 0,555614874105621$$

Pharaoh Chamber – surface section = half surface of pyramid base.

Pyramid base $S=53185,5844 \text{ m}^2$

Surface at Pharaoh Chamber level –

$S_k=26592,7922 \text{ m}^2$;

Half side of the base – $P=115.31 \text{ m}$;

Half side of the cut – $P_k=81.5364829 \text{ m}$;

Pharaoh Chamber is at the height of –
 $h=42.98207986 \text{ m}$;

Reverse value $\frac{P_k}{h}=1,79980782565739$;

Value of 0.555 is of primary importance in Genetics. That is the code of the complex as well.

All 3 pyramids are on the spiral of the Golden section.
Sphinx's gaze is directed at Sirius. It became known only about 1985.

Path extending from the third pyramid is directed exactly to another point in the proportion of f_1 on the large side of Golden Sectioned rectangle. If you cut the rectangle vertically this line runs exactly along and parallel to the plane of the vertical pediment of Sphinx headdress. If you **EXTEND** the

LINE of the south base of the second pyramid, it touches the Sphinx's right shoulder, marking a special place.

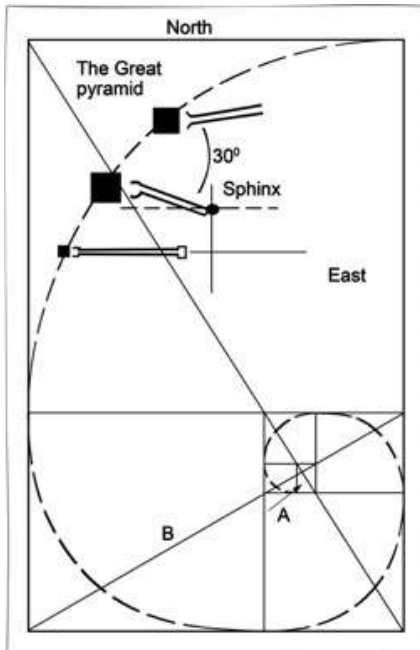

The central line that is equal to the long side of the Golden Sectioned rectangle and **EXACTLY PASSES** the front edge of the headdress. In other words, the headdress marks the exact center of the longitudinal direction of the Golden Sectioned rectangle, proving that Sphinx is placed in the sands not accidentally.

Why the line B is marked? The astrological wheel was taken with reference to the North pole and placed on the line with Cairo. The end of the line appeared to be at a special place on the planet of Earth – the area of 4 corners in the United States – the border of the states of Utah,

Colorado, New Mexico and Arizona. For the Indians the area of the 4 corners is marked with four mountains. The angle of inclination of the plane of the pyramid (calculation) is $51^{\circ}51'24''$.

If the pyramid is built correctly, it will pump water without any moving parts.

If we drew a circle on the Earth, its diameter would be 4 km (2.5 miles). It was believed that East is the direction where the pyramids and Sphinx are faced, but this is incorrect. Three oriented East **PYRAMIDS' FACES** are on the lines converging at one point on the horizon (on the arc). The point on the horizon is the point of helioarcic rising of Sirius, which is located not directly in the East.

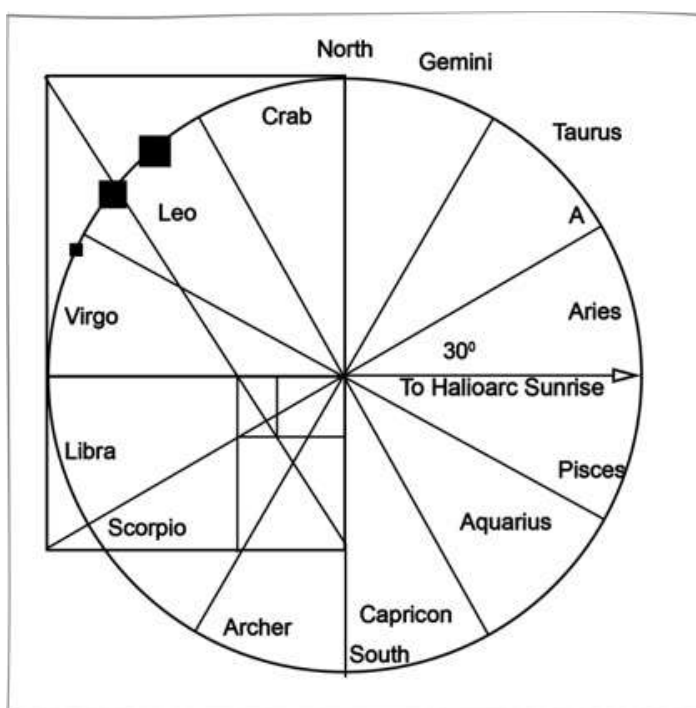

On July 23, Sirius rises one minute before the sunrise and at that moment, the Earth, the Sun and Sirius **MAKE** a **STRAIGHT LINE**. The eyeballs of Sphinx are gazing at the same place. The 12 sectors are the wheel of time. The three pyramids were placed on the Earth exactly according to the three stars of Orion. Deviation is $3.6'$ due to the orientation.

Pyramids are in the constellation of Virgo and Leo. If from the vertices, angles, etc. extend direct lines through the center, it will point to the range of accurate dates between Aquarius and Pisces, that is, for the period of time in which we live – the Age of Pisces transiting to the Age of Aquarius.

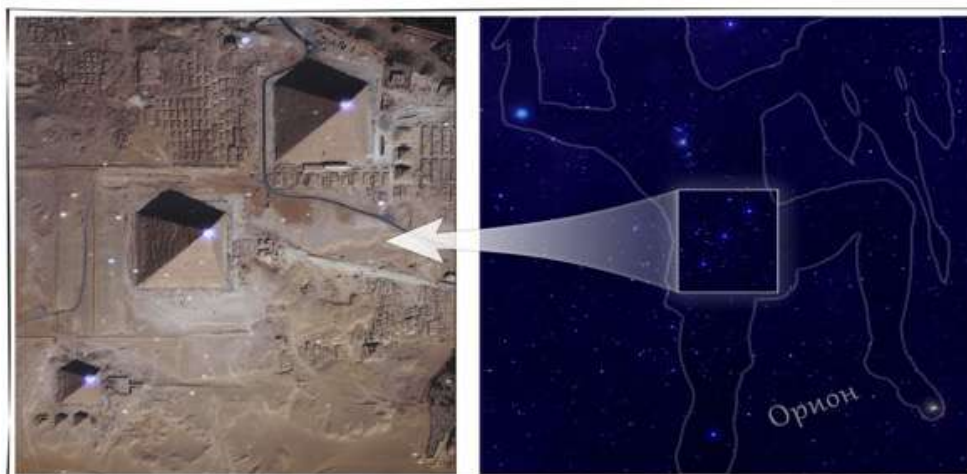

It is appropriate to mention some "tales, discoveries, speculations, and nonsense," etc.

The DOGON TRIBE in the district of Timbuktu (Mali) where there are rock carvings of fish, of Sirius A and Sirius B (revolutions around Sirius A), descriptions of Siriuses. The Information was confirmed **in the 1980-ies**. The Dogons knew what Neptune, Pluto, Uranus look like when approaching them from Space. On the rocks there are carvings of the paths of Sirius A and Sirius B for the period from **1912 to 1990** (confirmed by calculations). In Africa, where the Dogons live, the ***Sirius Star disappears from the horizon*** and is out of sight for a couple of months, and then in the morning of July 23, again appears in the sky for a moment before the sunrise – ruby-red, shining, almost **EXACTLY IN the EAST**. After 60 seconds the Sun is rising – it is a heliacal of Sirius (in the rays of dawn). At this point, Sirius, the Sun and the Earth are aligned on the same line.

In many **TEMPLES** there is a tiny hole in the wall, there is a similar small hole in the other (opposite) wall and so on until a certain dark room. There is something like a cube or granite rectangle of Golden section, located right in the centre and having a small mark. At the moment of the heliacal rising of Sirius ruby-red light falls on the altar for a few seconds, which means the beginning of a new year and the first day of the Syrian, or Sotichic calendar.

It is established that the **SOLAR SYSTEM MOVES** in Space helicoidally, in an elongated spiral which is a close relationship with Sirius.

Not only the Dogons, but the Sumerians knew about all the outer planets: – what the Solar system looks like when it is approached from the

Space. The Sumerians described the relative size of different planets as if they flew past them in the Space. They described what the planets looked like, what color they were (3000 years BC). They knew about the equinoxes precession. They knew that the tilt of the Earth's axis to the plane of the orbit around the Sun was 23 degrees and that it made a full rotation in a circle over a period of 25920 years.

Between Mars and Jupiter THERE WAS Tiamat planet (or Phaeton, destroyed during the capture).

Every **3600 years**, the planet Marduk (Nibiru with the Sumerians) enters the Solar System. This planet, that "flew into" the last time, became a real threat to the Earth. Its trajectory has been changed by N. Levashov, having described the events in his book. The movement of the planets is usually between Mars and Jupiter.

The third planet, coming out of Sirius B (Oceania), is home for whales and dolphins. The planet is completely under water.

All pyramids are **LINKED** with the **STRUCTURE**, made in line with the spiral of the Golden section.

From Ushmal (Yucatán Peninsula), it was laid down 7 churches, similar to 7 structures along the Nile. From Ushmal to Labna, then in Kibu, further to Chichen-Itza, then to Tulum near the ocean, and then descends, passing close to Belize and Kohunlich and then turns along the mainland to Palenque. From Palenque the structure is divided, going North and South.

To the South up to Tikal in Guatemala (the beginning of a new octave). In the end the spiral passes such places as Machu -Picchu and Sacsajuan near Cusco, in Peru. One of the main spirals ends in a place called Chavin in Peru (where there was **THE MOST IMPORTANT** religious center of the Inca Empire). From there it goes to the Titicaca lake to a point half a mile from the Sun Island (Bolivia), and then makes a turn of 90° and goes to Easter island and finally to Moorea, where it goes into the ground. This structure is called **"women's component of the grating"**. This is the information structure that runs along the base complexes of the Earth. It is intended for the control.

The "male component of the grating" moves to the North of Palenque. It passes through the ruins of the Aztec Empire and up to the pyramids of American Indians (Albuquerque, New Mexico State). Then the spiral runs to the Blue lake near Taos (new Mexico), which is the very image of lake Titicaca. This is one of the most important areas of the United States, which

had been protected a long time by the Indians of Taos. Near the Blue lake again is makes 90- degree turn. From there the spiral moves along the mountains, passing through Ute mountain (near the border with Colorado) and other mountains and artificial structures. Before leaving the California coast, the **SPIRAL PASSES** through lakes Tahoe and Donner and the lake of Pyramids. From there through the underwater mountain range it runs until it reaches the Hawaiian Islands, where one of its main components is the Haleakala crater, and then again turns South. It goes through the chain of the Hawaiian Islands, that stretches for thousands of miles all the way to the island of Moorea.

It's an **ENORMOUS UNCLOSED CIRCLE** that goes around the Earth, from Ushmal (forming a perfect spiral clockwise and counter-clockwise) to the island of Moorea in the South of the Pacific ocean.

A few pyramids were built by Ebrs in Tibet.

The fifth conclusion. During their stay on the Earth Ebrs (the Sumerians, the Dogons and others) interlocked the Life Support Systems of the Earth, creating **CONTROL SYSTEM** on the tracks of the power lines to prevent their use.

The sixth conclusion. To control the movement of the Earth in the given direction Ebrs used their own structures and objects, providing them with some artificial structures of control shaped like Cheops pyramid.

Under Sphinx there are 9 crystal vases enclosed one into another (theoratically).

The Museum of Oriental Culture (Tashkent): 9 balls, nested in each other. The balls are not detachable, all are visible..

Asoka Emperor, India from 273 BC –the society of the unknown 9 with encoded names:

1. The technique of war propaganda and psychology .
2. Physiology.
3. Microbiology.
4. The transformation of metals.
5. Means of communication – earthly and unearthly.
6. Gravity.
7. Cosmogony.
8. The properties of light.
9. Sociology and the laws of the evolution of societies.

Each of the 9 members of the society possessed the book, in which there was enclosed and continuously updated knowledge in a particular field of science. By the way, 64 methods of enciphering the texts **WERE KNOWN**. In addition to the function of the marker Cheops pyramid performs the communication function.

Let us consider the platform at the top of the pyramid as the norm for a regular pyramid, as well, and we get: the angle = 20,9051550°. is the angle in the dodecahedron (a dodecahedron vertex, the center, and half the edge)? Taking into account that the Earth's atmosphere is of the external structure of the dodecahedron, this pyramid is the pyramid of communication.

Communication octave is 51,125125.

The pyramid contour is the radiation grating of the 53,375 octave.

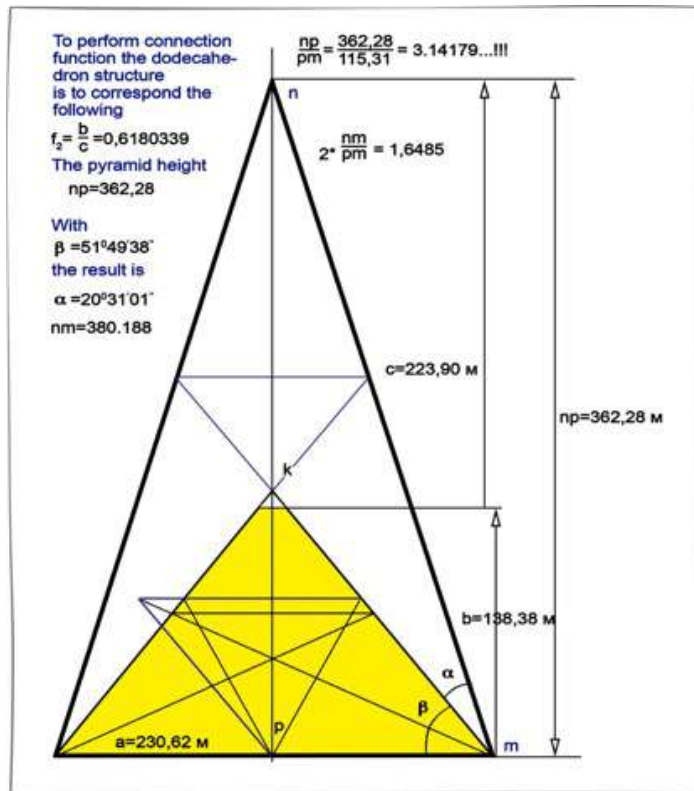

In contrast to the orientation grating that has a variance of 6' to the South, the pyramid of communication is strictly on the axis of the ion pyramid.

Pyramid orientation has the structure of 53.625. There are **NO DEVICES**, determining this frequency, but it is biologically perceived. The

pyramid is designed to operate in the original structure of the atmosphere (the dodecahedron). ***I am drawing your attention to it.***

At the starting point, the site of the great pyramid, we have got the Golden pyramid. Taking into account the inaccuracy of the input data (dimensions), however, we got the result that indicates not only at the meaning of the great pyramid, but at the fact that those who built it and made the calculations were not the ones who ran around with bows and arrows.

The Golden pyramid: $NM/2*PM = 1,6180339...$ and that is what refers it to the communication system. For thousands of years ion structure has changed, but strict compliance is supported even today, thanks to the radiation contours.

Now, based on this information, look at things more close to us in location.

The Church

As long as the time of the creation of the Earth **8640000** meridians **WERE LAID** (in science they are called magnetic meridians), about 1000 meters deep. They are energy cords. Only frequencies of low octaves have been measured (below the 42 octave). But these meridians are the conductors of high octaves as well; there are no instruments to measure their power, but the effects of their presence manifest themselves. In addition to the meridians, there is also a spiral; in the nodes of the meridian- spiral Hartman, Curie and Roentgen nodes are formed. Curie's are nodes of high

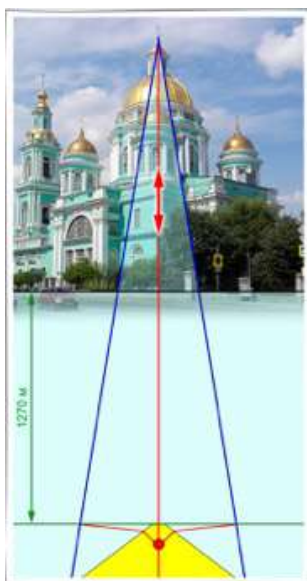

tension. If a terminal is put up over such a node, then within a certain range of the node there will be potentials increase of the atmosphere grating. If you add a little "stink" (light candles), a Human Brain can get something out of the atmosphere, for example, **NEW KNOWLEDGE**. There is also an opposite effect – the Brain is cleared of all the information.

Since the input of the frequency control for a particular genotype of the Brain (since 0 year) on the Earth there began building of a great number of terminals: churches, cathedrals, mosques, Buddhist temples.

Note that in Curie node there is **HIGH DENSITY** potentials in the frequencies of all octaves from 16 to 128, but a man perceives only the

62 (where to run or who to vote for). Today **66, 68, are the current Program for the Brain** (remember that). Frequencies of the octaves related to non-inertia mass are higher than 70. In the time of their materialization in the frequency **of 28-32 octave there might be tears on the icons**; that is, on certain material carrier, which in its structure has lead, sulfur and some other components. It has nothing to do with the divine miracles – take a wet towel and shake it at the **MOMENT** of **OCCURRENCE** of the next "miracle" – **you will get a shower of sparks**. If such a shower is manifested on a large area, expect to have an earthquake. This is not a miracle. So that all the "sheep" got all that is provided for them in due time, places of worship were designed and built for them. **Not** a single church representative **IS ABLE** to explain to you why **Church domes are shaped like onion, they take it for granted**.

All existing churches are **NOT** built by **ACCIDENT**. Control system is a pyramid, the apex of which is the Church. The location of the Church is not accidental – the top (the apex of the dome) is exactly aligned with the axis of the pyramid.

This applies to both the Orthodox churches, Catholic cathedrals and the minarets (of the mosques).

The Church is a double – action pump. In the time of reading the information (during the holidays) the arrow is down (the spiritualized leave the church). When the information is recorded with an arrow up – the release of waste and old information through the point (glowing clouds above the Church with a large gathering of people). **PEOPLE LEAVE the place** with new information and begin to execute what has been recorded. All holidays and all the days of the information withdrawal are scheduled **to dupe, with the reference to the divine and Holy events**. In the first place ministers of religion get the information; therefore, the selection of the clergy is not accidental. You might be extraordinary intelligent but at the main event you remain on the sidelines. As the **INFORMATION COMES** through the Church, it is considered to be the foundation of everything: morality, science, and all that is prescribed in the program. The **SHAPE** of the dome is **ONION**; the cone is also non-random. If there is no pumping up from the bottom, the shape of the ONION or cone contributes to the removal of the potentials from all present. Helmets, budenovka fulfilled the same function – **you do not need your brain in the war**.

There are **LOTS** of **INFORMATION EXCHANGE** systems, but the nature of their presentation differs. All genotypes **421** visit only the

synagogue, they do not need the Church (with their frequency control, they get and transmit information, avoiding holidays). Everyone else (goys or outcasts) are content with crumbs, but even there is some division into castes – it is determined by the shape of the dome.

Orthodox Christians **STAND** in line **LAST**, onion form does not let frequencies of direct connection pass (onion bending spectral form of **hydrogen (H+)** is the positive hydrogen of the central position. This subsequently **created quite a problem in the lack of control of the egragor of the Orthodox Christian Church – NO INFORMATION – NO OBEDIENCE** (even in the higher hierarchy). On the agenda there was an issue of the destruction of Orthodox Christianity. First in line for information are Catholics – their temples are precisely calculated by the cone, and they get all the information necessary to know only by the selected goys. Minarets and mosques do **NOT HAVE** such calculation, because more than 99% of the information is scattered, despite direct access to the source of information (to the floor).

At the depth of **1270 m** below sea level there is an information plane like fishing nets with nodes in Curie zones. If in Curie node (at the bottom) the gravitational potential k-structures above 122% are kept constantly a ball in the 63 octave can be formed. The diameter of the ball is from 2 to 33 cm, and it has already the properties of the piezoelectric element. It is exactly over such a ball it was **NECESSARY** to **BUILD** a Church. If there is no piezoelectric element, the Church is a black hole (**Cathedral of Christ the Savior**).

The Ball -concentrator was created initially while creating the information network. If the church (mosque or temple) are not on the axis of the ball, they **HAVE NO** sense and are to be destroyed (like in the time of the developed communism). Previously, each merchant sought to build a church for himself (forty times forty churches in Moscow, including the Cathedral of Christ the Savior). But the remained are only those that are in the right place. The Cathedral of Christ the Savior outside Curie zone and therefore useless, except for funeral services and lending more significance to the Russian Orthodox Church (ROC). As the deviation from the axis must not exceed 12 cm (axis tube), the location of the dome should be accurate otherwise, the Church is useless. The best option is the next step: to find the right Church (e.g., Elokhovskaya near metro Baumanskaya in Moscow. By the way, Pushkin was baptized there and given the name of Alexander).

The energy of the first pyramid at frequencies of the 71 octave, i.e. direct access to the Brain. The energy of the secondary pyramid of the 43.5 octave, i.e. processed **THROUGH** the appropriate **TRANSLATOR** (musical) information block. But according to the Program on **2005-11-14** **there have to be 49.5** transfer octave (up to 64 times higher), otherwise all listeners will **NOT UNDERSTAND** what is going to be transferred to them. The part of the inverter belongs to the second pyramid (the cross).

Out of the two options –to rebuild the church, or to dig a pit, today the second is preferable. By 1000 there had been 3260 concentrators, less than 1000 are left now (the rest are worn out and should be replaced), because the total number of correct churches, temples, mosques **MUST NOT** exceed the number of working concentrators. Looking ahead I tell you that the situation on **2005-11-22** at the start of the automatic attending of information blocks is rather interesting. The total control before that had shown the presence of the 49.5 octave (the pyramid is rebuilt), the Brain of the elected is controlled by the 49.5 octave, so the automates will dump everything that is necessary for the program, and even more. The counting of votes is made strictly according to the matrices, and the performance is guaranteed, as before, by the control system (plus attending machines).

There is unchecked information that the ball is the Holy Ghost, (like in the anti-clerical song by **Vladimir Vysotsky**: "I come back from work, rashpil put against the wall...") which sometimes visits the ladies chosen for the creation of another Christ, using the **IMMACULATE CONCEPTION**.

Thus the Church is a terminal for not only obtaining Program information, but also for cleaning the Brain from the accumulated debris. In synagogues they use candle-concentrators, the debris in the Brain remain, however This debris **CAN CAUSE many diseases** (this understanding will be useful to the reader for further knowledge). By the way, respectable restaurants (in Western Europe) and at homes at lunch time the candles are lit (for beauty). The actual purpose of candles is to **INCREASE** the **GRATING POTENTIAL**, which enhances the digestive process. These candles are used by all witches, magicians, and sorceress. Candles must **be of wax** – product of oil. This product contains sulfur; which frequencies are basic in the atmosphere grating.

For the "Golden billion" the Control System **DEVELOPED REINCARNATION** system, or "**Christ**" that is eternal life of the created Brain: **the reincarnation, in relation to the beginning of the process of "bringing all things in order, as before the invasion" – was**

removed in 2000 – the Church calls this process **Antichrist**, and the Church itself **IS BECOMING USELESS**, *which is being observed with our own eyes.*

Chapter 2. "Spiders' Laboratory Experiments"

Anyone who has once proclaimed violence as his method, inexorably has to choose a lie as his principle.

If an individual is able only to take and not to create; and is not able to compensate or eliminate the consequences of his or her deeds – such an individual can not be defined as Man. It's not even a personality, but a guided biological creature. It is able to have only its own momentum brain functions for daily chores and its temporary life support at the expense of the destruction of the surrounding environment harmony and an additional own imposed use as a biological object to implement the plans and Programs of the external control, launched by alien Systems. These individuals have to be called People. Man has been imposed this kind of condition in the time of the realization of the old Program processes. And that is how it had been happening.

2.1. The first stage of the violent "Civilization" of the Earth

From 17304 BC to 16684 BC (620 years), there was an active preparation for the execution of the Program "Energybiogenesis of the flesh cell".

Insulation with a layer of magma and other conversions of the contour protective plates of the Planet were made.

LANDING on the Earth happened in 16300 BC. First of all heavenly places were laid out, all the Earth complexes were annihilated along with those who inhabited them. In order to adapt the planet for their life support the population of the planet had to be **MADE A CLEAN SWEEP OF**. That time, **1240 million Human Beings** inhabited the Earth. The population of the Earth was completely annihilated, and all the humanoids were captured. The molten earth, which was found in Siberia in a large area, can serve as a slight example of the impact of aliens. All the found evidence of the existence of the ancient advanced civilization was carefully hidden, and is still being hidden from the society.

The aliens had worked out their own biological structures, but based on the samples of the former Human Beings. New Biological structures had Brain octaves from the 31 to 44. In order to control the resulting biostructures Ebrs had brought from Phaeton 12 billion Humanoids – programmable energy "blanks", which sometimes manifested themselves in the form of "come outs" in some individuals. They were stockpiled in the United States in the area of the Great lakes, in Peru, Tibet and Australia.

In addition to the delivered frequencies, samples of flora and fauna were transported by their fleet. But since the conditions on the Earth were very favorable and energetically provided, everything grew to gigantic proportions. That was the time of the dinosaurs. This experiment **TURNED OUT** to be **UNSUCCESSFUL**, as it was very energy consuming, and everything was destroyed.



2.2. Attempts to create people

From 16684 BC to 13344 BC (i.e. during **3340** years) Ebr' System undertook the first attempts to create humans.

Symbolic "First Civilization", but in reality – the first stage of the intervention.

Starting with the first aggressive invasion within 1040 years **ALL** the **PLANETS** were completely occupied. The capture ended in 17 914 BC. The

capture itself was symbolic, since all the Main Complexes on the planets of the interplanetary Cluster of the Earth had been off. Not knowing the structures of their construction, having a lower level of knowledge, the attackers just tied up all the planets with gravitational tubes (and later –with connections tubes), included imputed base generating frequency radiation protection of the Sun, surrounded the planet with "satellites" (as security convoys) and moved in the direction of the Big Dipper, in order to make out an active area of its reach. But on the way it was decided not to lose time and carry out some possible processes of changes in their own favor.

I have already mentioned that the capture of the Earth was simultaneously with the sweeping off the entire Mankind (in their physical plane of existence) and those control objects that were on the surface. All humanoids, as the energy state of the Entity of the entire diversity of the biosphere in their non-physical as well as Spiritual Essence of the **proto-Humans** with the octave of the Brain within **96-124**, being at the moment in the structure of the Earth's Atmosphere (in the gratings' octave of the 32 to 72), were **CAPTURED**. They could not be hidden "below", as all the Complexes before the attack had been switched off. As noted previously, the saved were **ONLY SPIRITUAL ENTITIES** with **the 224 level of the octave** of the Brain. Captive humanoids were kept in the interments' objects' cells (mostly type 440), landed on the Earth.

Then began the first "filling" of the surface of the planet, with "their water" (tritium) and the formation of sand out of the water. This process lasted approximately **620 years**, the surface of the Earth during this time has changed significantly and reached the **level h=-4300 m** (in relation to the present level of measurement). The Earth's atmosphere had not yet been structurally changed, but some gasses were added as part of its gas completeness which were necessary for ebr entities breathing (in their physical plane of existence) – the oxygen and fluorine were theirs (later the composition will be replaced).

Immediately after the installation of invaders' complexes of type 111, 222, 333, 444, 555, 000000 and auxiliary systems (shapers of the quantum fluctuations like those in the area of Stonehenge, and others), after landing the only one remaining today main object (type 960, or "Jerusalem", or the Third Rome – (as you like) located near Red Square in Moscow); and after landing **ALL OBJECTS** of convoy the trial "Program start" for the materialization in the physical plane of the first group (2%, i.e., approximately 17-20 million) of the captured humanoids (i.e. Earthly

spiritual entities of proto-Human with the octave of the Brain 96-124), previously transferred to the state of energies to the 31 of the octave (an attempt to simplify the Brain, since the invaders did not possess such a level of the brain).



The "aliens" in the **TRUE FORM** of their appearance were landed only after the chosen places had been prepared for their existence, that is habitable for their general state; (primary Control) and the completeness of the gas atmosphere had been created.

The aliens (Ebrs) are spiders 2.5 to 4 meters high depending on their membership in their existing hierarchy (for comparison, the height of a proto-Human did not exceed 1,88 m). It was impossible to escape for the initially embodied people.

Firstly, the human Brain (in the 31 of the octave) was very limited to aware the reality, logical functions were practically **BLOCKED**. There was no energy-information translation of the controlling character; the only recreated was the function of the flesh cells control and some limited control of the metabolic processes. For more, the invaders were not able then in their experiments with people. They **WERE NOT READY** for modeling the Brain construction of the proto-Human in order to substitute it for a more

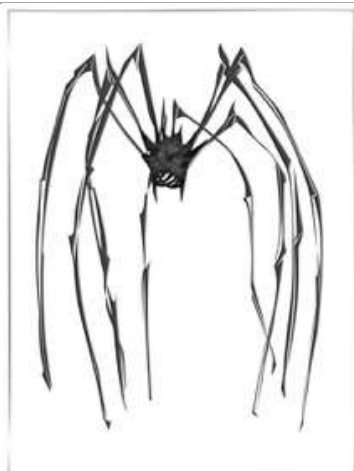

simplified construction of their brain in the human body due to the loss of the recourses after Phaeton's self-explosion.

Secondly, the area of the saved (formed) land after its initial flooding with imputed water took only 5-6% of the area of the total surface of the planet. The "continental" formations were mostly in the locations of the imported (transported) and installed primary (stationary) interventional Control Complexes or objects.

Thirdly, any attempt of creating self-born fauna of any long seasonal period was almost futile. The reason is that, as such, there was no synthesis control as a must for the habitat in general, and the unattended conception was giving up its being like a dying attempt of survival of the former fauna. The Earth **BECAME BARE DEAD** Planet, flooded with imputed water on the surface of which large-scale processes of annihilation of natural habitat, the barbaric destruction of all that could be preserved by chance in some way and fashion. And those fragments took place during this first stage, even in the initial period of the existence of the preserved groups of proto-Humans. Above the plates of the protective contour before filling it with water the interventionists had formed a layer of magma so that no humanoid was able to **RUN DOWN**, and to eliminate any attempt of the Earth Complexes and systems to **OPPOSE** the **INVADERS**.

In that active destructive mode **for 3960 years the first stage of the intervention of the Earth** had been taking place, a certain, **ALIEN** to the Earth Environment based on parasitism and violence **WAS BEING FORMED**. Someone might keep in memory the definition of this stage as the first Civilization (obviously, they have those unwavering "generic" reasons). It was **RUTHLESSLY DESTROYED** within 2 days in 13954 BC, as all the experiments with such "imposed Civilization" ended in its collapse and complete failure. Ebr System was not ready for such complications and did not take into account the level of perfection of the Earth, although all the formal knowledge, especially of the basic constants of constructive formation of the comprehensive energy model of the Earth and its being, **WERE KNOWN** to the alien system.

2.3. "The Second Civilization"

The second stage of violent "Civilization" of the Earth lasted 3150 years, from 13344 BC to 10194 BC.

At this stage, the interventional Program of "Energybiogenesis of the flesh cells" (the Program of "Energy-information dialectics of the development of genotypes of the Brain" had not been formed yet) acquired **MORE** significant activity in the reinforced attempts to create people (as a kind of proto-Humans), since the spiders flesh was imperfect and unacceptable in an attempt "to enter the Hierarchy of the Civilization development of the Intelligent orientation" (as well as the design of their Brain). For this purpose, the invaders used 21% of the imprisoned humanoids (spiritual entities), i.e. approximately 200 million individuals (from the state of their non-physical captive existence). The main **EMPHASIS** was **MADE** on Controlling the Brain by the primary energy-translation (of guiding character) via objects of 440 type. For this reason, all the settlement was formed in the range of the translation.

With the achieved results there were attempts to combine the people's flesh (people's bodies in the physical plane of their being through their Brain structure on the level and in terms of conversion into the low octave, up to 31) with the possibilities of the spider's Brain similarity. That was exactly what the principal attention was focused on.

Certain invaders' attention was paid to the **ATTEMPTS** of **INTERFERENCE** in the model design of **DNA**, **PROLONGATION** of biological **LIFE** of individuals (the average span of life was only up to 18-22 years), correction of metabolic processes of the cells of the flesh, attempts to transfer the metabolic processes to carnivore nutrition, and much more. But not so simple was the Man in the attempts to make' his likeness, for he is the fruit of the Creator's design! In this regard, the invaders did not make any significant progress. The invaders incarnated some other program processes to change natural habitat and the environment.

Water acquired only the fresh state. Its quantity was increased by lots of orders of magnitude; the former mineral inclusions practically did not exist. Moreover, it was the **BEARER** of **TRITIUM**. The program steadily required the mandatory presence of tritium in water, change in its frequency and density content in water as a source and carrier of energy for the functioning of the human Brain at the level of the lower octaves. A kind of "pipes" were formed, with a diameter of 300-400 m, to transfer water to the

objects, that required tritium (those "pipes" exist to this day at a depth of -2200 m to -3000 m). Water was intensely saturated with tritium.

The **SURFACE** of the **PLANET** was subjected to **CHANGES** as well; at this stage, the level of prime coating of the planet was "raised" again and reached $h=-3000$ m (in relation to the current level). Land geography expanded considerably. There began the manifestation of some semblance of discernment of the continental surface of the Earth. But it was only the primary image, even now depriving illusions many present day specialists of Geophysics, whose knowledge in geographical distinction of the surface of our planet rely on the theory of the separation apart (and the associated further "travel" of continents to different directions)

However, the truth about the formation of continents is based on "the foundation of digging", as an undeniable fact and on the trail of interventionists' achievements, and not on the theory of "spreading" and traveling of the entire continents. But why "the curve shapes of cutting" the continents on many borders of discernment is so amazingly alike? The answer to this question is **NOT ASSOCIATED** with spreading, it is associated with forms of scattering radiation frequencies (introduced by the invaders), with chemical elements formation at the ionic level, with subsequent formation of a "bulk firmament" (and filling with water, in particular) and so on.

With the expansion of the continental areas the invaders made **ACTIVE ATTEMPTS** on formation of flora and fauna as a complex element and process in general "civilization" development of the Earth. In addition to co-participation of flora and fauna in providing people's nutrition and their inhabited places it was required their active participation in the formation of natural minerals. Basically, all the attempts of intensive rehabilitation especially the fauna, were **DOOMED** to **FAILURE**. In the development of flora the complete similarity to its previous state was not achieved, the reason of those failures is the principal change of fundamental constants in all interventionists' creation of energies being. All the surrounding reality had changed fundamentally. There was no longer previous Program of operating "synthesis" of trees and plants. The structure of new chemical elements did not allow to come even close to any similarity in the field of flora. Thus, the invaders began **to form that kind of** flora, which turned out to be a certain **HYBRID** of the past and introduced processes of the synthesis control. Present day experts in the field of flora wonder to this day how dramatically and fundamentally their state was

varied in those distant years. They are trying to find the causes of such sudden changes in the variability of climatic conditions, not being confident themselves. And the reasons are completely different. There was an **ACTIVE EXPERIMENTAL** search for the most appropriate range in the field of flora to move to the complex processes of future changes, especially with the development of people, the perfection of their Mind and the Mind of the Planet, and so on.

At this stage, an active **FORMATION** of **PYRAMIDS** began as the necessary transmitting and receiving subordinate element for the functional operation of facilities and of Control Complexes. The height of a pyramid generally did not exceed 8820 m (except the pyramids in the Bermuda area, $h=840\text{ m}\div 9940\text{ m}$), and the design (and shape) was determined by the purpose and functions of the object, or complex, placed under it. When finishing such a creation the Pyramids were buried in sand. Some pyramids not buried in sand were executed of hard material of another kind, as if in the form of mountain (the Caucasus, the Alps, the Tibetan mountain range, the Andes, etc.).



Due to the negative results of the "civilization" development" in the part concerning people, this so-called, **"Second Civilization" was liquidated within a few days**. Again I am drawing your attention to the fact that, someone might take this stage for the "Second Civilization", but in the true essence of all the performed it was just a stage of civilization intervention of a violent nature, and it could not be the Second Civilization

of the Earth apriori. All **EXPERIMENTAL SPECIMENS** were liquidated within several days.

At the end of the Second stage of interventional interference in the civilization development of the Earth for 200 years there was a Programmed preparatory process of organization and partial Programmed correction of the Control functions at the created Control Complexes and (landed) objects for the conversion of all subsequent processes (changes) for the Third stage. For that short time from the Moon the first **SAMPLES** of "native" (lunar) humanoids (in their non-inertia energy substance) **WERE DELIVERED**, and also in the same way, some species of fish and birds.

2.4. The third stage of the intervention

Symbolic "The Third Civilization" (in fact, the third stage of the perpetrated intervention) had duration of 4070 years, i.e. from 10604 BC to 6534 BC. It had been the most satiated with all round experiments stage – from the formation of a stable interventional Control in all directions of its own civilization development until the **ATTEMPTS** to introduce self-created elements in the field of flora and fauna (taking into account the obtained humanoid fragments from the Moon). The details are not so important, since the invaders had **FAILED** to recreate the true likeness. However, one should note an important point, namely, the Control System of the invaders still was not perfect. For this reason, the true Control System of the Earth **REPEATEDLY** and **IMPERCEPTIBLY** interfered with its controlling correction in some episodes of the fully developed Control of energy being in the material and immaterial world.

Thus, as if a strong demand there arose for compulsory salinity of fresh water by those possible forms that had been established by that time. It made it possible to **RECREATE** to some **EXTENT** at first approximation some part of the conditions of life-attending in fresh water and give the underwater world some of model structure and functional significance oriented to ensure the created people in proteins and minerals of aquatic origin. Such unnoticed corrections occurred in the field of flora and fauna, and did not make it possible to leave **FULLY** and completely **THEIR** proto-forms in their development.

There was quite a lot of experimentation in the process of recreating people over this long period. In total 42% (about 400 million) captive

humanoids (energy-information entities of proto-Human with the former level of the Brain of 96-124 octave) were used. What was basically the main attention of the invaders paid to? Realization of only one Program of the "Development of Energybiogenesis of flesh cells " went on, and therefore the concentration of invaders' efforts on this issue, was basically focused. For this purpose, in the Atmosphere gratings all along the perimeter the processes of development of "**the Atmosphere Brain**" started in order to give some primary guiding in the existence of people without binding them to objects of type 440. But during this period it had **NOT BEEN** fully completed. Much attention was paid to changes in the human Brain Control of the metabolic processes of the flesh cells. During this period, people were brought to the state of metabolic processes under conditions of their suitability and ability to be carnivorous (initially without thermo-treatment). This made it necessary to **CHANGE** structurally and **SIGNIFICANTLY**, for example, pancreatic function and, consequently, to give additional functions to the Brain in its guiding and control of the metabolic processes of the flesh cells. This information is for those who is fond of vegetarianism and other "experiments".

Regarding the adjustment of the people's Brain structure all the experiments were mainly focused on:

- the **LOW OCTAVE** of the Brain (up to 31 – to add full submissive executive state, recreation of limited part of logic functions for the execution of elementary actions and motions, exception of rebellious behavior in the process of cohabitation, etc.);
- continued attempts to combine the Brains of people with the **DESIGN** and **FUNCTIONS** of the invaders' Brain (including those sent from the moon humanoids – their native individuals);
- prolongation of biological life of human individuals (no progress from the previous stage) by interfering in the DNA structure and many other experiments.

However, significant outcomes in matters of recreation of people as a likeness of proto-Man, but completely conquered (with all his life and suitability for a replacement of the combined Brain design with the invaders' Brain), had **NOT** been **ACHIEVED**.

Soon, within a few days this stage was stopped, in 6534 BC, and the entire carnal experimental basis was eliminated. Thus there ended the alleged "Third Civilization". After its elimination there was a certain preparatory process of the Program resetting of the control character as well

as **SWEEPING OFF** the consequences of the **300 years** of experiments (i.e. until 6234 BC). In addition, there were quite a lot of changes in the physical plan.

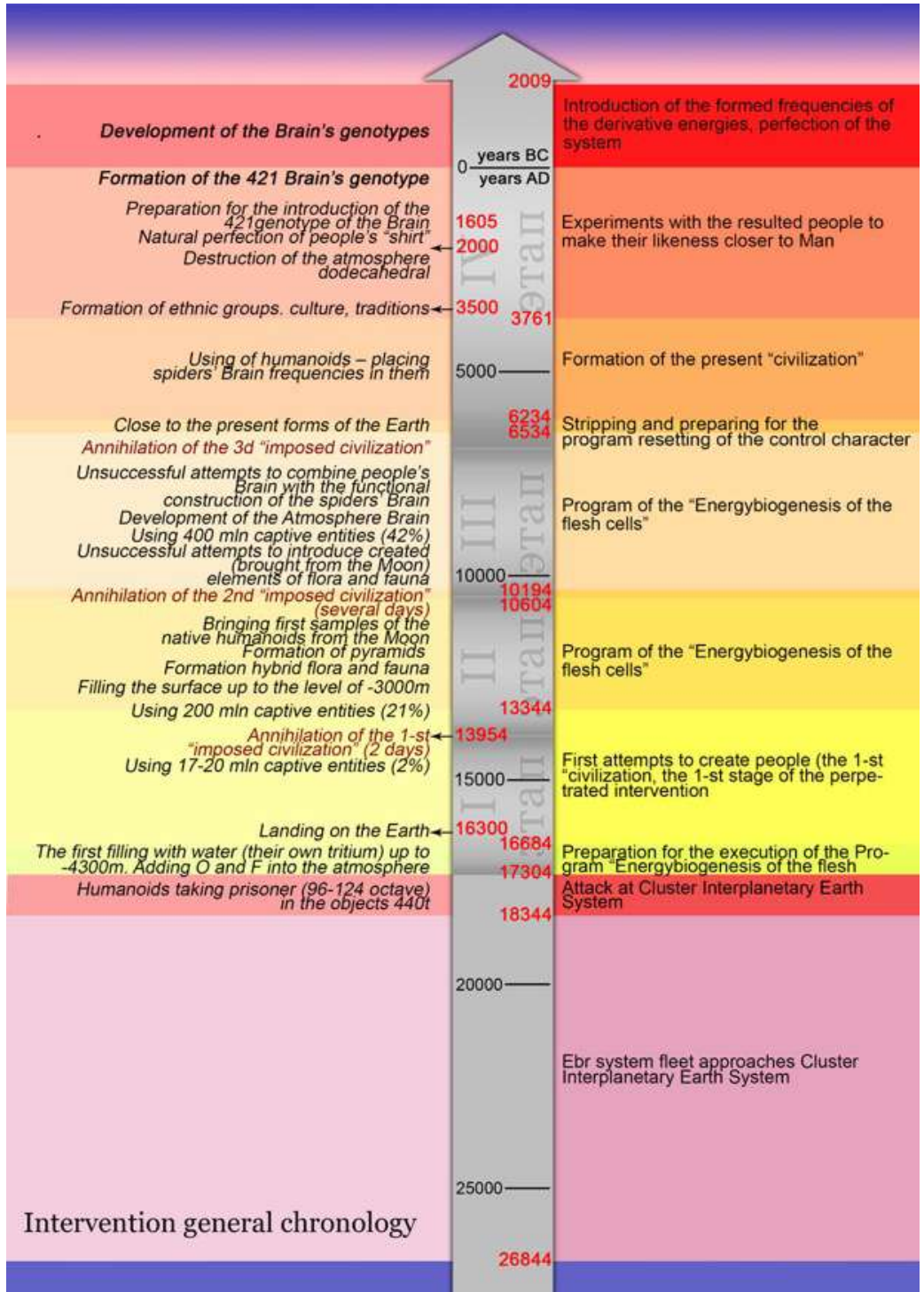

2.5. Preparation and the fourth stage of the violent intervention

From **6534, BC** to **6234 BC (300 years)**:

- preparatory process of the program resetting of the control character;
- sweeping off the consequences of the experiments;
- the surface of the Earth was filled up to $h=-1200$ m (relative to the present level), on the formed surface there were laid 8640000 energy tires of inter-pole direction (the geographers call them Meridians, and they are not 360 but a few more), connecting all Control Complexes and landed objects;
- nodes were formed (control servers and distribution energies servers);
- after this fine engineering, the whole complicated "installation" was filled up to $h=-100$ m;
- Huge masses of water 1500 m high were hurled to the Earth from the atmosphere hydrophone layer and from that moment sea water was first formed. That is the "worldwide flood";
- the surface of the Earth has taken the form close to the present.

They began **TO USE HUMANIDS**, inserting into them frequencies of spiders' Brain. Consistent frequencies setting led to good results. ***With materialization, all the humanoids got the Brain of spiders and formed the present civilization.***

Since 3761 BC there had been quite a lot of transient experiments with the resulted people in order to bring their likeness closer to the likeness of the Man before the intervention of the Earth. By mid-September, 3761 BC, this process of image similarity had been completed (the story "of the image and likeness" in the Bible and other legends).

Since 0 year AC the invaders **BEGAN** to **INTRODUCE** a large group of preformed frequencies of the derivative energies (relative to the basic that had been brought by them) and improve the System of control. The interventional System complicated and improved the Control on the Earth which had been created by them. They introduced the control of the state, executive behavior and control of efficiency resulting aspects of groups and **INDIVIDUALS** from people. An extremely **IMPORTANT** step was **the introduction of reincarnation**. It was the only way out of difficult situation for the whole ebr System, which failed to solve the problem of non-

conformity between the long duration and continuity of the necessary executive functions of people with limited life-span. They **FAILED to get to the fourth codon of DNA** and mastered only three of them, and only because of this life for the created people was so limited in time.

Further interventional (ebr) Program objectives in relation to people became **MUCH MORE COMPLICATED**. They rushed to get people as representatives of their Space (because people look significantly more decent and potentially more perfect), but having the Brain of a spider and the possibility of transition to the octave of energies 44 and 56 (i.e. above 31 octave of the material world) in case of unforeseen emergencies on the Earth. In addition, the group of spiders, which was located on the Sun as their **SELECTED ELITE** in the amount of 1,200,000 individuals, would have to make "golden elite" on the Earth by their Program, but with more perfect Brain – the **72 octave**.

2.6. Technical implementation of the Control

On the 2009.11.15 the functioning of the basic Complexes and Systems of the invaders was eliminated along with those who served them, i.e. spiders and those enlisted. It took the hardest **16 years**. There are still lots of aftermaths of the intervention, but the **MOST IMPORTANT** and irreversible is **CARRIED OUT!** Part of the interventional Complexes and objects saved as functioning trophies, as the loss in time and energy spent should be compensated with something. **THEY** have **ALREADY** been applied in the solution of creative tasks and elimination of aftermaths of the intervention.

In this regard, in a simplified format I'll show you how the Control had been technically carried out by their Systems. But I will throw light upon this issue in the limited frame of understanding only the fact of **ADMINISTRATIVE INFLUENCE** on the condition of people and their subsequent resulting behavior. This is exactly that sacred "From outside" passed in the numerous epics and legends. Technical and technological details are not touched upon, in order **NOT** to **OVERLOAD** the readers' Brain. Of all the Complexes and objects, involved in the old System of the Control, we will note only the main part, without which the Control would **not have been possible:**

№	Complex	Purpose
---	---------	---------

1	Chekhov	Control tower, main control system, setting Programs for all complexes.
2	Kailas	Main control system, correction in accordance with the atmosphere Brain program for all genotypes on the Earth.
3	China, Tibet	The atmosphere state control during the correction of the atmosphere Brain and all communication channels of objects type 560, 520, 500, 440, and 960.
4	The Urals	The coating of the brain (31 octave) for all genotypes (from single-celled creatures to man).
5	the Baikal	System of emergency rescue of humanoids 42, 44 in case of a disaster (evacuation from the Earth).
6	Easter	Compliance Control of the Brain coating and octaves from 49 to 59 for all genotypes.
7	Kailas 2	Routine (weekly) monitoring of the Brain.
8	Peru	The Main Complex of control, maintenance and storage of humanoids (for future use).
9	Andes	Control of all humanoids on the Earth.
10	the Caucasus	The Main Complex of control, guiding of the "Golden billion" – 42 genotype.
11	Elbrus	Territorial complex – the European part of Russia, Belarus, Ukraine, Bulgaria- total control of genotype 42.
12	Kazbek	Territorial complex – the East and the South Caucasus, Central Asia, East of Asia minor – full control of genotype 42.
13	Ararat	Territorial (first on the Earth) complex – Asia minor, Greece – complete control of genotype 42.
14	Alps	The Main complex of control and guiding of the "Golden million" – genotype 44.
15	Alps 1	Territorial complex – France, Spain, Portugal, Italy, Western Europe – full control of the genotype 44.
16	Alps 2	Territorial complex – Eastern Europe, Germany, Baltic States, Scandinavia – full control of the genotype 44.
17	Sarajevo	The main energy complex of octave 53.5 (gratings replenishment for all types of radiation). The first atomic bomb was worked out in Germany.
18	California	The main Complex for preparing new genotype – 46 (to be introduced in 2012).
19	China, Tibet	The main control complex on the Earth, setting standards for all complexes.
20	Easter	The coordination control node via Kailas.
21	Moscow 960	The main object of the Control System, all the brain matrices of 42, 44, 46 and Moshiach.
22	Greenland	Control of the Atmosphere brain.
23	Ireland	Computer center. All types of calculations. By the way, Ireland – second in the world in Computer programming. At the same time, Ireland is the birthplace of unsolvable mathematical problems.

It is quite sufficient to pay attention to the purpose of each Complex which convincingly demonstrates the fact that all actions in the Control the processes of implementation did not leave any chance to be left without old System's control, even in minor episodes of actions and events. A skeptical opinion or judgment will only mean the unwillingness or inability to go further into the matter. Technically, from the first steps of any Program simulated process to its **PRACTICAL IMPLEMENTATION** via the enlisted – everything was in the field of effective attention of the Control Systems. Moreover, the old System had the technical ability to lead and to **COMPEL** to the planned **RESULTS** in all that was determined by them through various set up Programs.

While creating the atmosphere Brain (**from -2200 m to 12,400 m**) new frequencies were introduced in the original structure of the atmosphere. This process began over 2000 years BC. Strictly symmetrical structure of the atoms dodecahedrons was destroyed (some connections with the icosahedrons were removed). Each removal of such a connection led to the creation of a new chemical element. If you completely remove dodecahedron, you get icosahedra structure of bor. As the basis was 16, 22, 28, 32 and 42 of the octave, exactly in these structures everything was replaced.

A certain combination of octaves 16 and 22 led to the creation of gas and the combinations of octaves 16, 22, 28, 32, 42 – to the formation of oil. White oil has **additional octave 47**. Besides, octave 53 was inserted; as a result "explosive mixture" was made. But these combinations were intermediate and could not be used for the formation of the Brain, as they contained the catalyst – sulfur. Sulfur is a product of the Brain activity (note – sulfur in the ears), but it **CANNOT** be in the composition of the Brain. But this "explosive mixture" has one property – it is impossible to transfer to octave 56 without it, which is extremely necessary for all representatives of the "Golden billion" in case of emergency, when, for example, they **HAVE TO BE SAVED** from a nuclear explosion. Since the intervention in the Atmosphere structure by the interventional System it has still been presented in **6 layers**:

№	From	To	The Purpose
1	-4400	-2200	Atmosphere Brain grating connection, the atmosphere Brain
2	2200	0	Atmosphere Control system (-2200 m is the hydrophone depth)
3	0	1200	Base layer
4	1200	6200	Accumulative layer
5	6200	12400	Layer of materialization
6	12400	36400	Layer of the atmosphere protection

In the accumulative layer there was a weekly process of accumulating or clearing the frequencies and their subsequent distribution among other layers. In the layer of materialization there was a transfer of all types of humanoids into material structure (putting "shirts" on them), as well as materialization of UFOs after their lifting, if necessary. Each layer, except No. 3, has sub layers, in which, different structure frequencies performed the same function.

In the initial period each object, from which humanoids were obtained, formed an individual "cupola" for them inside of which the development of the given group took place under the Control of the object, without reference to the environment. It was impossible to go out of the "cupola", the outsiders were not allowed in, as well.

When the Earth Control System was introduced in the state of a new functioning, set up by the invaders for themselves, there began binding of all biostructures to the local habitat within a certain distance from the Object. First and foremost, this environment was formed **by the Andes**, then **the Caucasus**, and from 0 year – **the Alps**. The colony of humanoids living in the Object "cupola" was called "ethnic group", hereinafter used the term "nationality".

Where did ethnic groups come from? In its original form, all "passengers" on all the objects **LOOKED** perfectly **ALIKE** and the Brain structures were alike. But the objects do not transfer material bodies, and therefore when landing in a "chair" any material structure folds into a small fireball, about the size of a match head. When rolling itself in a ball there might be some slight distortions. Therefore, the Brain potentials before rolling in a ball could be different. On the way the object could fly through a meteor and can pick up any muck in the form of those germs that are typically found by "modern science" on the meteorites. In addition, the environmental parameters of the Object arrived, and the parameters of the "passengers" delivery places could be different in structure and filling (on the Earth there was more oxygen). If the original Brain when moving lost at least one frequency (and the Object's Generators **DID NOT NOTICE**), then many of the original properties were lost at the delivery place, as well. The missing properties were filled in with "stock parts" (with expired shelf life, as the movement was more than one hundred years). That is why each Object brought what had been loaded in it, but poorly packed. Each ethnic group had the **SAME STRUCTURES** of the organs, but **DIFFERENT STRUCTURES** of the Brain.

The brain, or the properties of biostructures, as the System of external and internal control, memory, orientation, information exchange properties mostly, were the same, but had **DIFFERENT BASE**. The Base is an individual property of an ethnic group against which metabolic processes of reception and transmission or language translation were built. In Georgia, for example, the basic element was manganese (Ossetians have another basic element; it's a different ethnic group). When in Georgia the deposits of manganese were completely depleted, the population got the process of "thickening" of blood and increased pressure in the pulmonary circulation. ***In practice, it was noticed in 1989.***

The Control system, taking into account the location of the "cupola" for 3500 years before the new era began attaching them to the layer of atmosphere No. 2. Using the features of the Brain of ethnic groups in the first place, each of them received basic radiation frequency, relative to which there was a rearrangement of atmosphere layer No. 2. The number of radiation frequencies was more than 100. Using the database, i.e. the radiation frequency specifically **TO EACH** ethnic group, their quantity and the number in each ethnic group were brought to the Program specified values.

Primary life styles (culture) and borders of the habitat of each group were introduced and found with reference to the layer of atmosphere No. 2. Boundary of habitat no longer had a cupola shape. In the center of the former "cupola" "capitals" of ethnic groups were founded. Regarding this, the construction of further settlements was carried out, etc. In the course of development with the objective of stabilizing Control of the execution of the Programmed processes limitations were introduced **WITHIN** each ethnic **GROUP** which do not allow different ethnic groups to merge, i.e. be mixed. It became surrounded with imaginative and behavioral introduction (concept and realization) of different traditions, beliefs etc. If the group did not meet the conditions of the Program requirements, i.e. had non-programmed variations in its development of any irreversible character it was **ANNIHILATED**, usually by **OTHER** ethnic groups. But each group had its own object of defense, and if the group was annihilated, then the Object was destroyed too, it was transferred to the off state.

THE PRINCIPAL PROGRAM goal was to create the "Golden million" based on "the Children of the Sun", and all ethnic groups had to be only **CONSUMABLE MATERIAL** for conducting Program experiments to improve and bring the Brain to the desired genotype and in the right quantity

in line with the Program. The intermediate group of the "Golden billion" had begun to take shape since **0 year of the new era**. At the same time, representatives of this group had already had some connection with the atmosphere Brain, placed in the layer **-2200 -4400 m** deep. They could have up to 12 language translators for communication with other ethnic groups, got firsthand information necessary for the "creation" and "implementation" of new technologies to improve their social settling. They formed their own societies and the structures of their Control, founded primitive, but their own economic system, etc.

Societies and states began to appear, take shape and improve. And it all went allegedly like the way some historians are trying to give an account in pictures. But everything is not as simple as we would like it to be! **NEITHER** Marxist-Leninist basis of the fundamental production relations, **NOR** the theory of the World market, or any other contemporary theories or the theories of the past **HAVE BEEN ABLE** to answer the question how numerous societies have been formed. What qualitative and quantitative "special recipe", how many and what kind of ethnic groups had to be collected to create a proper society, in what quantitative and qualitative limits? Whether this process is guided or prone to natural formation? Why periodically there were demographic problems? Was a 'recipe' for the formation of all societies the same or was it unique for each group? And finally, who determined the boundaries of the states, without any disputes or military interventions, i.e. some other way? There are plenty of questions, but they are being ignored, passed over or looked for a convenient explanation – beyond the truth.

The fact is that after the invaders' realization of the processes for creating altered, to fit their Program single grating of the Earth's atmosphere **THERE IS NO LONGER** any **NEED** for a hard reference of ethnic groups to certain location, as the atmosphere grating itself has gained all the necessary properties to support the existence of the ethnic groups diversities to any point of the Earth. From this moment, a deterrent from the chaos and mixing of ethnic groups (nationalities), as previously established societies by force, have become newfound by the societies and assigned to the performance exactly by them some private Program functions, which, in accordance with its Target Vector of **FUTURE PHENOMENA**, actions and events predetermined the whole Program structure of the subsequent events in this society. In the future, it was classified as historical **STAGES** of the **DEVELOPMENT** of civilization, states and their groups, etc.

The system pre-held Program distribution and gave specific functions to each society taking into account the placement of Objects and Complexes in relation to the established and well-functioning system of energy and information support, communication and control systems. For all that clearly defined characteristic, territorial demarcation under these societies functions were determined. Moreover, each territory for future settlement was pre-saturated with a certain set of "natural" resources to the levels, which should be sufficient to ensure the formation of material goods and services exactly for the society which would settle on that or other territory having a set of specific functions endowed by the Program.

The **MAIN** geographical **REFERENCE POINTS** in the definition of the borders between the States were served by both placed Complexes, and Objects and **FREQUENCY REFERENCE** through the Brain of specific genotypes with frequencies of some chemical elements that were present in the deposits of this territory. This frequency reference in the first place, was the **SECRET RECIPE** for the selection of specific numerous or uniform types of ethnic groups in society, which was necessary to perform the full function of every society. At each step of the Programmed performance of its functions the society could and was supposed to have a certain number of performers of specific genotypes of the Brain. This exactly determined the quantitative composition of the community, and this corresponded to the demographic change with reference to the specific stage of the Program execution.



Any artificially introduced unprogrammed interference in the correction of a demographic problem was not able to solve it. However, any forms, methods and aspirations in all attempts were futile. But it has always

been able to **ORGANIZE CALAMITY**. So, for example, was **ARTIFICIALLY ORGANIZED** a very serious problem for Russia, connected with the ill-conceived initiative to enhance migration flows from the countries of Central Asia. Any proactive interference of a random performer, not provided with the programmed framework, has always led to some significant consequences. So, more than 95% of people who were involved in the non-programmed cultivation of virgin lands immediately fled across the country at the end of this artificially inflated farce, not having achieved the target. But the main part of the "fled" has not returned to their former locations and to their former way of life. Most of them were darted off from rural areas.

That way **THE FIRST** endless **STREAM** of "roving specialists of all hands" and later called "the municipal quota" was arranged; and the aftermaths of which have never been corrected in the development of the agrarian sector of the economy. These were the people with the **BROKEN PROGRAM** in their minds and deprived of the former frequency connection. The similar situation was with the group of "BAM" (the workers of the Baikal-Amur railway), and so on. The alternative example is the voluntarily-forced resettlement of oil- industry workers from Azerbaijan to the areas of Tyumen petroleum industry. They, having frequency connection of the Brain feel well in the northern areas, succeed in labour productivity and are not going to move back to their former motherland.

There might be a natural question: Why were there so **MANY** bloody **WARS** to defend one's territories? Are they futile losses and unnecessary human grief? Do not worry –it was that way, regretfully, in line with the old Program one of the variants of the **LIQUIDATION PROCESS** of the unnecessary Brain genotypes after a regular stage of its perfection. The present day existing "Golden million" is the **EXPENDABLE MATERIAL** that for the completion of the Programmed stage was being transferred to the "Golden billion" on common grounds of annihilation of all those, whose brain genotype did not meet the new Programmed requirements.

2.7. Formation of Consciousness

The embodiment of the specified, including the **formation of consciousness**, was carried out by practical providing **ALL** the necessary **INFORMATION** orientation of "the strategic and current" nature, which

for a long or short period of time were translated to the Complexes, Objects and preformed Control Systems. The latter, in turn, through reverse energy informational translation operated, i.e. determined all subsequent terms of performance and found commands related to the development of structures, functions, and the design of the energy- informational translation for people and the development of their Brain throughout a long process of their supposedly "natural" perfection. ***It was through such programmed policies like orders, the process of development of the materialized by the interventional System people*** – from their state of "Cupola" Control¹⁷ of the being to the present state of the accomplishing "Collapse of their Civilization" occurred.



The formation of consciousness of the genotype of the Brain is a **DISCRETE** sequential **PROCESS** to bring the System functional Controlling information in the conscience of individual members (performers) at a specific "historic" moment through Systems of Control and Operation of accompanying and supporting Complexes.

Thanks to this, with the application of systems of Control and Operation, there was implemented the Comprehensive support in the execution of the Programmed actions that led to a pre-planned System results and events in the development of human civilization for the realization of strategic Programs of the interventional System: "the Development of Energybiogenesis of the flesh cell". Along with the transformation of the Brain the biogenesis of the flesh cell was also changing while maintaining the external forms of people. Man was **TRANSFORMED** into Ebr in his essence, getting all the implications of such transformation in the form of a complete set of **ALL** parasitic functions.

Man is a structure that ***is simultaneously in two spaces – in the neutron (proton) and antineutrinos (electronic) spaces.*** All sensations are formed only for the neutron space. There are other Brain

Man is a structure that ***is simultaneously in two spaces – in the neutron (proton) and antineutrinos (electronic) spaces.*** All sensations are formed only for the neutron space. There are other Brain

¹⁷ "Cupola Control" – the Biostructures at any celestial body possess only that frequency spectrum which is provided by the System. This frequency spectrum is provided at the expense of UFO. (a cupola is created under which the biostructure's life is supported, and for which the frequency balance is unique).

connections (with the neutrino space), which **WE ARE NOT GOING TO** consider here. The entire development of life on the Earth is determined by the frequency dependencies generated by the difference of two numbers of the Solar system. The number **Pi** is not irrational – it is the ratio of the length of the contour to the radius. In the Solar system **2 Pi**: 3,000864... (to the 124 decimal place) and 3,1648... (to the 124 decimal place) are used. These numbers specify not only the wavelength of the closing circuit of the Solar system, but also **GIVE** its **EXACT DIMENSIONS**.

The base of any living structure is hydrogen and the formation of ions is subjected to the same difference in numbers. For example, a Man formed in the system of Alpha Centauri, when delivered to the Earth and linked to the existing life support system can look like a crocodile. If an object (a UFO) having created in another system, did not provide restructuring of its structure to the values of the system's constants which it intruded into, it automatically was subjected to transmutation with the formation of the inert mass.

To solve their tasks on the Earth Ebrs had to introduce profound changes. They almost completely subjugated **all 18 life support biostructures' systems**. In particular, they have created structures at the frequency of 53.375 (gamma radiation). Spiders live normally in this atmosphere. Radiation over 124 x-rays does not harm them. By the way, cockroaches, which they have brought, too, are tolerant to radiation up to loss of color (look like glass).

Ebrs sought to **penetrate into the mystery of a living cell** since their protein cell by its energy resources was much less than a living cell. But more details I will provide you later in a special Chapter about the Cell.

The brain is the most complex set of a biological structure and is the result of multimillions work on the formation of a biological structure (of a Man). The brain, of course, cannot be formed by itself from dust using chemical reactions. ***The brain is simultaneously a bound up state of 3 spaces – neutrino (the highest), antineutrino and proton, or ion.***

In their experiments with humans the aliens first, tried to raise the octave of the Brain. It gave the Mankind the level of a **CAVE MAN DEVELOPMENT**. Further **EXPERIMENTS LED** to appearance of the colored races and different species of monkeys on the Earth. In the course of study and cognition of Man they have adjusted for themselves the biological "shirt" raising the octave of the Brain. Eventually they were able to improve

the Human Brain and **brought it only to the 66 octave**. Some individual experiments gave the 71 octave of the Brain. In order to control each "bio shirt", it was attached to the **PROGRAMMED HUMANOID**.

A brief chronology of events* on the Earth from 3500 BC to the present time is shown in **the table**. The dates specified in the table are approximate and calculated by a special technique, since at that time of events, the time parameters were quite different. For example, for the Earth **day and night = 48.64 hours, a year = 864 days**.

Time of the event	The events happened ¹⁸
Around 3500 BC	<ul style="list-style-type: none"> - Control system, in accordance with the location of the "cupola" (borders of ethnic groups location), binding them with reference to atmosphere layer No. 2 - basic radiation frequency (more than 100) for each ethnic group were obtained, in relation to which there was a restructuring atmosphere layer No. 2; - using radiation frequency for each specific ethnic group, their quantity and number in each ethnic group was brought to the Programmed specified value, introduced and found primary life styles (culture) and borders of the habitat of this group with reference to the layer of atmosphere No. 2. Borders of the habitat no longer had a cupola shape; - inside each ethnic group limitations were imposed making it impossible different ethnic groups to merge, i.e. be mixed. It was surrounded with imaginary and behavioral introduction (concept and realization) of different traditions, beliefs;
2000 BC	<ul style="list-style-type: none"> - creation of the atmosphere Brain (from -2200 meters to 12,400 meters). New frequencies were introduced into the original structure of the atmosphere; - strictly symmetrical structure of the dodecahedrons atoms of the atmosphere grating was destroyed (some connection with the icosahedrons were removed). Each removal of such a connection led to the creation of a new chemical element. The coordinator on creation the atmosphere Brain was the Caucasus Complex, because all of the major and known deposits were around the Caucasus;
2000 BC- 1605 BC	<ul style="list-style-type: none"> - the period of creation and natural improvement of the "shirt" (body of people); - up to this point, the Control System worked out all the processes of Energybiogenesis of the body in the image of the captured humanoids under the protection of Objects 440 type. The settlement was organized under the "cupola" area, primary fragments of communication with the changed environment were worked out, as well as habits to the new conditions of the environment;

¹⁸ Here there is only a short version of the event. More detailed information you can get on "Salvatorem.ru" "About flora and fauna" and the works "Basic information on the Mankind formation", Parts 1,2.

	<ul style="list-style-type: none">- mastered the basic skills and basic hand tools simplifying and labor saving in making food, clothing and shelter. This time should be defined as a period of pure virgin natural values. All values were determined by the Program and dictated by the Objects of 440 type, focusing all the people's being on training and improving the body for the conditions suitable for the future functioning of the 421 genotype of the Brain. The ability of logical judgments and estimates of the observed reality, the ability to receive and transmit the perceived information in the form of speech – Objects 440 were used for this. All in all they provided 384 "languages";- under the operation of the Andes Complex (a separate settlement of "Maya") a temporary, specific task was worked out– testing of separate mantissas of the future Brain genotypes. This was the incredible mystery of "Maya";
1605 BC- 882 BC	<ul style="list-style-type: none">- formation of the Brain genotypes;- under the Control of Complex Ararat (Caucasian Control Complex) in 1605 BC the genotype of the Brain 421 was formed. It was the first successful attempt of the interventional system to put in their (spider's) Brains in the "shirt" of people. The coverage area of this experiment – Asia Minor, Greece. The Control center – Jerusalem;
882 BC- o AD	<ul style="list-style-type: none">- formation of the Brain genotype 422 under the control of Kazbek Complex (control center of the Caucasus) on the territory of Eastern and Southern Caucasus, Central Asia and East of Asia Minor;- an active period in the evolution of people associated with the possession of their own "self", open confrontation of people with the natural environment – development and conquering the World. All control and support were provided by two Complexes – Ararat and Kazbek. Developing the advantage of one genotype of the Brain the dominance of another was provided and supported;- a sharp jump in development and perception of new social values. The level of achievement in their development and acquisition of new structures of social organization, Control and arrangement of a more perfect being, etc. still can be imitated in their separate parts;- Rapid rise in the development of many fields of culture;- an active process of more expressive territorial definitions and boundaries for each genotype of the Brain began.

2.8. The development of the Brain genotypes of the alien Control System

Let us briefly sum up the results, which might make many of you feel uncomfortable, nevertheless everything was exactly that way – I think you will get to the meaning of how we ***"have sunk" into such a life...*** Understanding enables us to assess what is happening today, and this, in my opinion, is the most important.

0 -1433

Continuation of the **DEVELOPMENT OF THE BRAIN GENOTYPES** Program and implementation of other Programs:

- Complex Ararat created the first Brain genotype 421 in 1605 BC;
- Complex Kazbek created the Brain genotype 422 in 822 BC;
- Complex Elbrus created the Brain genotype 423 in the 0 year, having completed the formation of the first group, i.e. the Brain genotype 42.

The Brain genotype 423, as more perfect, was the basis for further development of possible additional executive functions of individuals of a higher operational order and further improvement of the Brain genotypes. In 1433, the first Brain genotype 441 (Control Complex of the Alps 1) was created. In 1841 the first Brain genotype 442 (Alps 2) came into being. In 1990 the first Brain genotype 461 (California) was introduced. By 2012 the second cycle of formation was supposed to have been completed, i.e., the work on the formation of all individuals of the second group, i.e. with the Brain genotype 46. The first cycle was completed in 0 year, or exactly, 0000-01-17 at 02-11.

THE MAIN TASK of the Control System was creation of such biostructures, the Brain of which had to fully comply with all the Programmed orientation of the System and be fully guided. For all that the realized control of the entire being of individuals and social organization of the society were to be arranged only in the shape of a pyramid (since it was required by the brought in **BASIC FOUNDATION** when making up the Control information):

- Level 1 – Moshia (Allah, Buddha, etc.), and the Brain genotype 481;
- Level 2 – "Golden million", the Brain genotypes 461, 462, 463, 464, 465, 466;
- Level 3 – the "Golden billion", the Brain genotypes 441, 442;
- "The Golden million" – "priests", managers in finances, science, society, and distribution of all kinds of material goods and services;
- The "Golden billion" – production and replenishment of material goods, preparation and provision of services.

The rest of the population is not required, it had to be annihilated by the end of December 2012.

With approaching 0 of the New era, the level of authority of the individuals with the Brain genotype 422 sharply went to the decline. People-

Gods began moving into the oblivion, their Programmed functions were over. People-Gods lived too short life! To solve the problem of extending biological life of separate groups of individuals old Control System had not been able, the approach to the fourth Codon of the DNA had not been found. On the 7 of Jan 0 year at 02 o'clock, 11 minutes Control Complex of Elbrus introduced a new Brain genotype. The Program of "Reincarnatio" was brought in, i.e. the continuation of a humanoid functioning that was provided in line with the Program with **CONSISTENT**, gradual gaining of **SEVERAL** "shirts" (bodies) so that it might be able to complete execution of the assigned functions. The Program "protection" was introduced, popularly known under the name of "Christ". Between the material "shirt" (a biostructure) and the phantom (matrix, can be "humanoid") the intermediate frequency of 51.5 octave is placed (all in all there are 22 frequencies). These frequencies provide communication with the atmosphere (cubic structure).

The second function of the imposed frequency was **to provide the process of reincarnation** (the used matrix was **NOT THROWN AWAY BUT PASSED OVER** to the next shirt). **Hence the symbolism of mother and child**. First the protection system was tested in 0 year and since that time in every Program cycle 2 days before the introduction (15.22 Moscow time), the protection has been removed (symbolizing the death of Christ); after setting new frequencies the protection with new properties was fixed, and all Complexes on the Earth attended the **NEW SYSTEM**. It was started the process of implementing the historical episode on the formation of specific state of control in arranging people's being – "the power of money" as finally formed Administrative Program (ritually symbolized with the crucifixion of Jesus Christ). The Central Control server is Byzantium.

Exactly since that moment, the basic might of the Administrative action with Elbrus Complex was entrusted on the Control instrument "from All Mighty", i.e. religious confessions. Total active might this Control instrument manifested **on Easter, 385 AD** (the phenomenon was symbolized with the crucifixion of Jesus Christ).

Fundamentally **NEW** basic foundation of spiritual values – **RELIGION**, which acquired major Administrative work, was introduced. Religion in all variants of confessions has become not only the basis of all spiritual and subjective values, i.e., the **BASIC** effective **INSTRUMENT** for the implementation of the functions by the performers from the Conceptual

Power, but also has been the **PRINCIPAL LINK** in the determination of the structures of statehood, authority, and law.

In 1433, the Programmed stage of the development and improvement of the **ENTIRE SPHERE** of Control covering with its executive Controlling incarnation through the processes involving the whole of three-variant Brain genotype 42 was completed. Technical, energy informational and other perfection of the Caucasus Control Complex in total with other Systems and Complexes as well as the functions of increasing and complicating the **CONTROL PROCESS** through the Brain genotype 42 was completely exhausted in its capabilities, its development and its long-term adaptation of the Brain functions.

1433-1841

A significant contribution to the enhancement of the role and giving another level of the Programmed importance in the Administrative influence of the "power of money" came from the time of introduction the 441 genotype of the Brain, performed by the **Alps** Control Complex, in the spring of 1433. Exactly during this period of gaining Control functions by the individuals of the Brain genotype 441 the balance of the undermining power authority was withheld due to the «power of money»; and the authority on the basis of outdated methodology of religious values had lost its leading functions forever. Strengthening the Brain with extra mantissas of a different order **ALLOWED** the representatives of the Brain genotype 441 to **ACQUIRE** completely **DIFFERENT STATES** in everything. A sharp jump occurred in the "scientific" knowledge, which led to the practical application of revealed technologies for the implementation of machinery in all spheres of people's being. Alpine Complex significantly complicated the process of formation of the Administrative Programmed substance of Ebr state of Mind of the period.



As a result, a special awareness of the environmental "objective reality" by the individuals of genotype 441 provided them with the **OPPORTUNITY** to **IMPLEMENT** the Control Program process of being in a new form. Having realized themselves as a "selected and perceived some deep-seated mysteries of this World", they surrounded their circle with the sacral aureoles of different orders and clans, secretly getting all the authority in the Control of the World leading countries

under themselves. The process of formation of the organized financial system got activated and was brought into a state of complete **Control of the 441 genotype of the Brain**, with involvement of experts of other genotypes, disregarding all previous material authorities. The specified genotype in a short period managed to gain a **SPECIAL Administrative FUNCTIONS** in society, ignoring all sorts of law standards, and seize all legal and Control functions **IN EVERYTHING** that was connected with people's life arrangement, completing the process of getting the "power of money" as a very significant power function of the Control process.

With the introduction of the Brain new genotype both previous ones were not eliminated. They were subjected to constant Programmed and functional correction and development, including the development and improvement of values basis, adapting their own position and involvement in Executive processes.

Genotype 421 was applied to improve the processes of exchange, **PRIMARY DEVELOPMENT** of the value equivalents system, as a germ in the phenomenon of future financial systems on large areas where they did not live previously and did not organize such a system.

The previous genotypes of the Brain were replaced with a small but **SMART**, thrifty, and very **CRUEL** genotype both in decision-making and in actions on their implementation. Representatives of this genotype in a **SHORT TIME** have **GAINED** a leading and powerful position in all influential spheres of both the arrangement and Administration of the society's being.



Having more subtle logical structure and higher-level functional capacity in reception of the Administrative information, the representatives of this genotype of the Brain, **NOT POSSESSING** great representational quantity, were able in a short time to break most of the established stereotypes of the methodology values, structures of statehood and law, and got down to the processes of social transformation of societies on a large area almost simultaneously. Material values have gained lots of new forms and changed significantly in scale. Active development of the **RULES** and laws of the **NEW** exchange began. The society has got an impetus in the development of banking system and formation of the elements of the world finance system.

A steady and solid influence on all the process of being acquired the provided amounts of the circulated substitute. The control, possession and application of the circulated substitute (gold) were taken by the representatives of the Brain genotype 441.

All subjects' values and their basis changed ***under the dictatorial influence of sacral orders and clans***. The construction of the society's authority social structures, the formation of economic systems (economy) on the basis of slavery application of the "economy Man", Programmed accumulation of unsolved social problems – that was the way of training and polishing functional opportunities and abilities of the 441 genotype of the Brain. It was a **DIFFICULT STAGE** of acquiring the ability to Operate in tough and difficult conditions in the coming into being machine age.

Through practical activities of the performers of the 441 genotype of the Brain in a short historical period it was started the incarnation of the Programmed process of labour division, which played a crucial role in the decision of "ways of civilization development".

By the end of **1840** the leading position of the individuals of the 441 genotype of the Brain in the field of Controlling the societies began losing its power. Conflicts inside the clans and secret orders were growing in number. Disintegration and confrontation substantially affected their authority functions in the societies. The effectiveness of their actions and the legality of the performers dropped essentially. The Control System was getting ready for the introduction of a new Programmed genotype, and the World was to endure a bloody historical period for a century and a half.

1841-1990

By the beginning of 1841 the Programmed stage of the development and perfection of the Controlled state of the evolution of the 441 genotype of the Brain had come to **ITS END**. There began a **NEW PERIOD** of evolution of Ebr state of Mind. There was a requirement for the next stage of the Brain development, i.e. the introduction of a new regular genotype. In this regard, during the Easter of 1841 **the Alps 2** Complex was turned on in the active state, which by the introduction of the 442 genotype of the Brain symbolized the beginning of the fourth stage – the era of **DIGITAL INFORMATION CIVILIZATION** of human development, the stage of the bloody genotype hegemony, **1841-1990**.

FINANCIAL REVANCHISM having organized as the Programmed system, only began to gain momentum and was not able to assume **ABSOLUTE POWER** through the "power of money". It needed time, much of the legitimacy and massive scale. But "The Might of Power" with influencing participation of secret orders and clans, due to a number of their inner reasons, essentially reduced its Control effectiveness. Exactly at this "historical" moment, with lending the Brain **NEW MANTISSAS** the System through its Control Complexes, including the Alps 2, created all the conditions for significant changes in the substance of Ebr state of Mind at the time, strengthening it with aggressive destroying nature in everything. The introduction of this genotype of the Brain was very **IMPORTANT** for the old Control System. This step of development had completed a long stage of the Administrative developing process – preparation of the "Golden billion".

The Conceptual power leading performers' awareness of the surrounding "objective reality **WAS** entirely oriented and expressed in the "Might of power" for all a century and a half. While realizing this Program the executors arranged and accomplished stage by stage bloody way: **Revolutionism, Militant fascism and Destructive democracism**. All these and similar "**NAMES**" are brought in the text for better understanding the current processes, comparing them with our ideas, which, in turn, are **DIRECTLY** "connected" with our **KNOWLEDGE**.

This period the entire depth of the sphere of "knowledge" was only oriented on the development of technologies for the **PRODUCTION** of weapons – from military sabers and bayonets to weapons of mass destruction and their carriers.

The state of the "Authoritative of revenge" in sphere of Control, that lasted until 1990, allowed representatives of the 442 genotype of the Brain to fully accomplish their Programmed functions. They managed, on the bones and blood of hundreds of millions of people, to gain the unwavering authoritative state in all spheres of the world community being Control, create Programmed social and



governing structures of local and global plan, ensure the required volumes of accumulation and concentration of financial resources Control and circulated produced substitute in their hands, etc., and also prepare a different social situation for the future "Golden million". So this period by reason of distinct Programmed changes should be divided **into three stages: the first stage (1841-1904) – REVOLUTIONISM. The second stage (1904-1946) – the MILITANT FASCISM. The third stage (1946-1990) – DESTRUCTIVE DEMOCRATISM.**

1904-1946, Militant fascism

On the side of the System a significant Programmed correction and target reorientation of all Governing processes was carried out including the Programmed executive states of "**needs, labour and work**": the February revolution, the October coup d'état, the 1st World war, the seizure of power by fascists in Germany and Italy, the 2nd World war, etc. – Programmed processes, executed by the old System.

The Programmed process of the executive character for people – "The Elimination of 50 million of the used and dispensable individuals, as the aftermaths of the Programmed process of Energybiogenesis of the flesh cell". The executive actions in the active form of their manifestations started to happen only since 1934, further they turned into the Second World war. By the month of May 1945 (Victory Day the 09 of May –is also the Programmed process), the second stage of this period approached its completion. Is it Cynical? Beyond Human comprehension? Yes! But it was exactly that way. And all, that "historians" are holding forth at this subject **HAS NOTHING TO DO** about that. All this "history" had been done only for the sake of the certain genotype of people. I am sure that it is **ALREADY CLEAR** to you, Reader.

All the Governing correction of the Programmed terms on the side of the Control Complexes have been completed The process of the territorial

dispense in carrying out the general Programmed Control process of the two **MOST VALUABLE SPHERES** of being – *capitalist and socialist* have been recorded.

1946-1990 – Destructive democratism

At Easter, 1946, the General state of the Control System was switched over to the final stage of the realization of the Programmed processes:

- to conduct and complete mutually regulated antagonistic phenomenon of The Programmed development of the two specific goal-oriented spheres of being –capitalist and socialist as a single Control process of the developing the 44 genotype of the Brain. The introduction of some elements of liberalism, as the basic foundation of creating structures in the sphere of authority. The special purpose basis for the socialist sphere of being was the introduction of elements of democracy with relevant Governing design and the entire social construction;

- to complete the generalized preparation for the transition to the **UNIFIED SYSTEM** of power and Control structures on the liberal-democratic basis, which was to be the Control basis for the next stage of development of the Brain genotypes;



- to bring the Global Financial System Control organized on the basis of the **IMPOSED VALUES**, in the state of goal-oriented harmony with the basic principles of the Programmed process of the Global Control for connections into a single Control state the "*might of money and might of authority*" in order to complete the preparations for the transition to a new stage of development;

- to introduce the digital design basis of the Control System information, through the provided knowledge without gaining profound understanding of its essence, through the technological process as the underlying basis of digital technologies for the substitution part of the Brain functions and preparation for the transition to another level of separate Control of the genotypes with the subsequent stage.

While completing the third phase of this stage (i.e. by the time of "ripening" the executive states of "needs" to the level of full readiness, to dismantle all gained in joint efforts and distribute it according to the

belonging to a particular genotype of the Brain), the process of keeping back was both pointless, and inevitable. **ALL THE CARRIED OUT** Control was transferred to the base of digital technologies on all aspects, in both the goal-oriented spheres of being of capitalism and socialism. The Global Financial System made the most important qualitative leap, universally switching over to the electronic Control records and electronic money. They, in turn, began to have certain properties regardless of the nature of the use of the provided volume of the circulated substitute (printed money and their support).

The finance accumulation and technological preparation for the transition to the next stage of development of genotypes of the Brain had been completed.

1990-2009

The **Control Complex of the Alps** (Alps, Alps 1 and 2) gained their perfection. By the end of 1989 it had secured the carrying out of the final stage in the formation of the "Golden billion" (the genotypes of the Brain 44). The stable dominant power-legal and social position, unshakable possession and full Control of the main material values of the Planet, including the circulated "wealth" (substitute), by the representatives of the 44 and partially the 42 genotypes of the Brain were provided and supported. The transition to the next and final stage – the development of the 46 genotype of the Brain (the so-called "Golden million") started.

In 1990 California Control Complex started to work and entered into an active phase, it marked the beginning of the **INTRODUCTION OF A NEW 461 genotype of the Brain**. The basic server to Control these processes in Russia *was the object placed in Saint-Petersburg* (under St Isaac's Cathedral). Now, I hope, it became clear why St. Petersburg "team" "came" to power in Russia. And in the course of the narrative I would like to note that the programmed goals in the development of the genotype of the Brain was fixed on giving "the shirt" a higher level of Energybiogenesis, based on the **SIGNIFICANT INCREASE** in the period of its biological life and lending them more advanced parameters of the Brain by **SETTING DIFFERENT** functional mantissas and a certain raise of the octave of the Brain. However, in mid-2013, the "object" was "turned off", and the consequences of the work produced by it have been balanced by the introduced peripheral complex "Vyborg". Not the last role (in tactical terms) was played by the Generator that was moved from N, Levashov's Castle in France, but more about it – a little later. I just want to note that all the yelling of both the representatives of the Russian Orthodox Church, and of so called

"authority elites" around St. Isaac's Cathedral – are the consequences of the happened processes that are directly connected with the Brain activity of specific genotypes. But let us go on.

California Control Complex in line with the Program was to conduct a personalized formation of the object mind of **SEPARATE** individuals or **LIMITED** groups of them by matching their level and state with their Programmed functions. Such a process was to significantly change a lot in their authority-social status and position, provide a special legal basis for their existence and their executing the Programmed operations on conditions of the unquestionable legitimate state of "FAS" as the power from the Almighty, as well as to accompany and provide the entire sweeping of the power pyramid for the Programmed actions of the "Golden million".

In April 2001, the Program of the individuals' development of the imposed 46 genotype of the Brain (462-466) was **COMPLETELY ELIMINATED** as not realized in its performance. This significantly influenced the correction of the executive actions of individuals at all levels of the Authority of that time (governing, sacral orders and clans, religious confessions, administrative, military and law enforcement agencies of the local and international scale). Here I'd like to note that still there were some unattended actions of the representatives of this genotype of the Brain. And when in 2012 these unattended actions were interrupted, then we could see with our own eyes the **PROCESS OF DEGRADATION** (in all stages, up to aging and diseases) of the genotype of the Brain, which to this day has been (temporarily) in power.

The established executive circumstance has radically changed the performance, or rather, non-performance of the events previously scheduled



by the old System in the frame of already uncontrolled Target Vector of phenomena, actions and events. Their shaping of the Third World War (August 2012) as the earlier laid in Programmed process of events *function of the elimination of all individuals that are not related to 4XX genotype of the Brain* was **NOT** the **FATE** to happen at all, despite all the efforts and

attempts of that time! The old System support of this "important episode of the events" **HAS NOT EXISTED**.

The year of 2006 was the beginning of the "Golden million" formation, that is, of those who were to have perfect protection and direct connection with Ebr Control System. The rest were **NOT NEEDED** and could have been annihilated (a part could have been saved as serving staff). Reincarnation was also no longer needed. And ***"mother and child" – as well as the lifespan was to be regulated by Ebr Control System***, and the "Golden million" would have to "live forever", having all of the captured. No revolutions, no terrorists (for a transitional period it was necessary to form the desired amount of power structures to destroy them). Some, having information about the formation of the new protection and of the "Golden million," (**since 2007.04.03**) hurried to legitimize their rule (Ukraine, Georgia). With the introduction of the new protection it would not be necessary to support the tales about the Christ (there would be no one to tell). These were **Ebr** plans of **2006**. Exactly these plans were circulated among the Jews through their super priests. But there was one thing the selected "Golden million" **DID NOT REALIZE** – that **THE SELECTED** would have had only their "shirts", but the Brain would have been of that Ebr million, which was on the Sun. It is hard to believe it, but it was exactly so. And if you are able to comprehend the above written and will analyze the events that have been happening before your eyes, at least, since 2000, you will make sure of it.

In March 2008 Ebr Control System was destroyed. Serious systemic failures in all Complexes of the old System took place (the **RESTORING** original **SYSTEM** of the Earth Control interfered), which led to irreversible processes, and not only in the attendance and support of the Programmed actions of the performers, but also in the development of genotypes of the Brain. ***Since then nothing has been interfering in the recovered Control System of the Earth*** (that is what you can observe, if you have already learned to observe) to make sweeping of all the aftermaths on the Earth and surrounding space. But if you are "lucky" and you have "SvetL" Program and there is a chance for you to **"have the Bath"**, then there is a great **PERSPECTIVE** for Your **FUTURE**.

The Alien System Programs

The alien Control Systems	Brief summary
0-1840 AD	The "Golden billion" formation Historically, i.e. from the moment of the input Control frequencies for the "Golden billion", namely since 0 BC, large scale construction of specialized terminals such as churches, cathedrals, mosques, Buddhist temples and shrines of science started to build on the Earth.

	<p>When creating information networks initially in some nodes of Hartman zone translation information concentrators shaped like balls were placed. The diameter of the ball was from 2 to 33 cm, it had the properties of the piezoelectric element. It was exactly under such a ball a church was required to be build. By 1000 BC, the number of such concentrators reached 3260 balls, until Easter of 2009 their number did not exceed 1,000 units. At present, active balls in the Programmed Control state no longer exist. On the surface over such a concentrator a construction of a specific cult design was built; the total number of which, i.e. "correct churches, temples and mosques should not have exceeded the number of functioning concentrators.</p>
<p>500-year- long, 1500-2000 (recorded by Nostradamus)</p>	<p>There had to be created conditions for the formation of such a Man genotype who would be completely governable by the alien Control System. On one of the stages of the program in 1845 the creation of radiation web (a sophisticated design of energy gratings in the layer of -4400 m +12400) embracing the Earth was completed. After that, the Earth was supposed to be only for those who could be controlled using the properties of the web and such «Development Program", which would make it impossible to return to other methods of the Brain development. People (and animals) being connected with such a web, were conventionally called "electronics", that is with a chip in the "shirt" (according to the old Program).</p>
<p>Cosmopolitism – a 100-year long 888-1999.</p>	<p>The Program of cosmopolitism had the following objectives:</p> <ul style="list-style-type: none"> - setting a single financial Control; - introduction a single ideology for all genotypes of the Brain 421 (Ararat), 441 (Mont Blanc, Alps) and the unified system of information perception by making up tales, "archaeological" wonders, annihilation of all structures and bearers of a different ideology; - working out and creation of a unified mechanism of the society Control, testing technologies of societies Control, capitalism, fascism, democracism, liberal democracism, socialism, and so on; - providing Control over all natural resources; - preparation of conditions for the arrival of the Earth Ruler (Moshiach).

At present, **more than 70%** of the Control Systems, Complexes, objects and servers of the old System are destroyed, and those saved are either "de-energized", or **REPROGRAMMED FOR** the **TEMPORARY** use in order to ensure the smooth **TRANSITION** to a new state of being, especially in the biological field. As a result in **2011.04.24 the final change of the Governing System was done, that is the energy being Control is passed to the true recreated Control System and its Brain.**



The process of transition to another, i.e. earlier imputed true path of civilization development of the Earth with Intelligible orientation **WITHOUT RECONSTRUCTION** of the true Earth Control System is **IMPOSSIBLE** in itself. Also it is impossible to implement the real goal of the Earth existence and the execution of its basic functional endowment given to IT during Its formation, namely: in the process of implementation of **ALL EIGHT** stages of its discrete Integrated civilization development, in order to achieve perfect harmony of only **NON_INERTIAL ENERGIES STATE** and its Mind, finally becoming the hypostasis (entity) of the Universal Mind!

There has come very short but very rich in the phenomena the period of **TRANSITION** to the active state of the New Program execution, especially in the part where the Humanity's future directly and indirectly is **INVOLVED** in the phenomena, actions and events of a completely different format. The Programmed settings for the Control Complexes and Systems of the Earth to **SUPPORT** from the **OUTSIDE** have already been completed (as part of the **Super system** and the **System** for THE **SPECIFIED** execution **PROCESS**). In the next Chapter I will try to go on explaining and clarifying the specific points of the past events, and mainly, the events happening now and forthcoming. I do not stop perceiving and amazing at the fact how far **N. Levashov** "was able to see" (what was, and, most important, what is happening today and will happen). And this was **NOT A PREDICTION** but an objective view of the processes that have **ALREADY** been expanded and **ARE TO BE expanded in time**. The truth in its

everyday perception is relative, as a rule. Subjectivity and objectivity are not that diametrically opposed things, as it is regarded by the majority, considering themselves to be always right. And since the border between them is **NOT DEFINED**, it is not at all difficult to shift it wherever you want. However, I'd like to assure you that reading this book and making your own conclusions, you will not be able to do so. It is not enough to possess the truth; the truth should possess all of us. And it is becoming to be objective. But the **OBJECTIVENESS** is always **PROPORTIONAL** to **KNOWLEDGE**. And for me, that is another reason to go on with the book.

Chapter 3. Fundamentals of the material world and the formation of the Brain genotypes

...if you don't believe in something, "leading to collective hallucinations" the entire civilizations, first of all this something should be thoroughly explored in order to be able to oppose Faith to Knowledge.

It is no good to be satisfied with the achieved comprehension. Anyone is mistaken who makes efforts, gets some idea and then stops. First you have to make great efforts in order to **HAVE NO** doubt that you've got the basics; then to work hard to bear fruit — and this process never stops throughout your life time. Don't rely on that level of comprehension that has opened up to you. Just say to yourself again and again: "That is not enough". The idea that we live in an enlightened century, in the age of intellect, in fact, is **BASED** on **NOTHING**. We have enough information about ourselves and our Planet, but we **HAVE NO** idea about how to use it. Most of our traditions and patterns of behavior originate mainly from the so-called Middle Ages. For the early life forms it was not easy to get out of primitive slime, without catching up some of it. The same applies to rooted system of values. The most suitable place for the present day traditional ideas, in my opinion, is in a museum or in the books on the history of civilization.

One of my principal tasks is to come after the people who are **ABLE** to think and understand the happening. It appeared not so easy as I had thought. And the question is not in **PROVING** something in the events happening. The question is to **FIND** those **WHO** to prove. To find people who are able to think on a large scale. Not on the scale of a particular industry or knowledge of something, but on the scale of the whole Planet, however pathetic it might sound. What good is it to prove the correctness of the knowledge to those who initially take the **PROPOSED INFORMATION** for craziness? With the same success you can invite an old woman selling sun-flower seeds to discuss the project on millions. No honest, good, brave Man, **THINKING** in the scale "of seeds", is able to **TAKE UP** a large-scale work, or at least its comprehension. It is unrealistic for such a person, not

because he finds some defects in it, but because it is **BEYOND** his **PERCEPTION**.

To talk to people, thinking in the usual categories, on the subject **UNUSUAL** for its vast scope, is tantamount to talk to children. Most people, no matter how smart they are, will not take such a talk seriously. Therefore, people, in general, understand and share my position on the importance to transfer the knowledge I have got but not having large-scale thinking, **ARE ABLE** just to **TALK** on this topic. Even can "stand next to you". But they will **NEVER DO** anything specific. The person chooses what to do regardless of the presence or absence of the intellectual, administrative or financial resources. A very knowledgeable professor, a powerful official or an oligarch-billionaire are able to realize their great resources as an ability to implement some small projects (to build a country house, for example). An uneducated and poor person with microscopic resource can **STRIVE to DO** tremendous things. And this kind of people is growing in number. Here I mean the intentions and potentials. Whether it will be possible to implement them or not is another question. A thinking Man among the people indifferent to anything looks like a plane, moving along a city street. Everyone is honking to it, as it is in **EVERYBODY'S WAY**, but only because it is designed to **FLY**, but NOT to **RIDE**.

My life has convinced me that people always act not basing on the knowledge and understanding of reality, but according to their scale of thinking. That is, the scale of man, in this context, is not determined by the dimensions of the body and the number of lived years, but by the depth of thinking and attitude to the world. And then your scale of thinking will **DECIDE WHERE** the resource of your knowledge is going to be used unless, of course, you have it and go on increasing it. For example, in one case, for the formation of the situation in your Country or at least the place of residence. In the other case, to adapt yourself to the situation **CREATED BY OTHERS**. But it all starts with understanding the **BASICS** – the foundations of the world in which we live today. And who formed these foundations and in what way?

3.1. The basics

Life is the possibility of producing and carrying on metabolic processes. It is present only where **the Control System is created** and, in

relation to the critical ratios within acceptable, there is control and development of the environment that **IS** exactly the **OBJECT** of the control. There is no life outside the created environment unless there is another Control System. Modern physics does **NOT KNOW ANYTHING** about the Control System. Religion connects it with God, but shamans and wizards – with the presence of spirits. Everything that is known to science about the structure of microcosm are electrons, protons, quarks, elementary particles, etc., resulting from the accepted basics: **Solid body → Liquid → Gas → Unorganized plasma.**

Atomic structures are mainly investigated when considering only solid bodies. ***The Model of Bohr's atom is the main conceptual framework of both Mendeleev's table and Fleorov's table.***

The most fashionable name in science is "field", this name is given to any new manifestation of the electric charge properties. At the same time, it is reported that in Space there are **up to 5% of the "studied" matter, the other 95% are of unknown origin.** They are often referred to as a "black hole" ([press conference of the Russian Academy of Sciences](#), devoted to the Day of Russian science on February 7, 2006).

If **ANOTHER MODEL** of an atom is taken as the basis different from the models accepted and its existence is proved, then the entire science is scattered as science.

Atomic structure is dodecahedral-tetrahedral-cubic structure. The Central cube is a system of octahedra and icosahedra, embedded into each other (16 attachments). All the instrument base is created in relation to the Central cube; outside the cube it does not work.

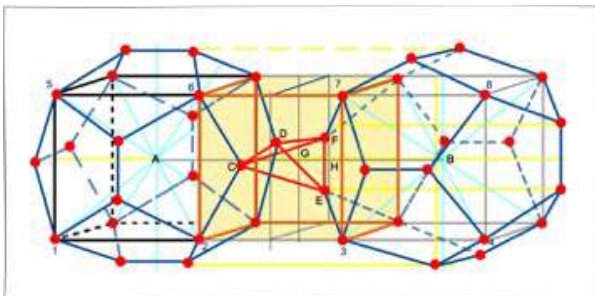

All frequencies in the atomic structure are built on octaves (powers of two). The basis for the construction of the Central cube **ARE OCTAVES** (brought by the Ebr system and unobtrusively embedded):

16, 22, 28, 32, 50, 54, 64, 66, 68, 72, 78, 88, 96, 112, 118, 122, 124, 128. Octave **128** is the maximum octave of **NO** longer **EXISTING** (interventional) Control System.

And some concepts:

- **potential of the octave** is an even, positive, maximum charge in a given octave $1.24^{(n1-n2)}$;
- **gravitational potential of the octave** – uneven, alternating, maximum difference of adjacent potentials $1.24^{(n1-n2)}$;
- **the angle of the charge sliding** – the angle of the charge turn relative to the node (for the central cube this value = 39.6°).

The structure of the dodecahedron with the nested icosahedron is unique – any attachment of this structure into each other can be calculated. The number of attachments – 44. Every other attachment increases the octave 4 times, the initial value =128. And the same is with "SvetL" Programs that are NESTED into the Generator on the basis of calculations.

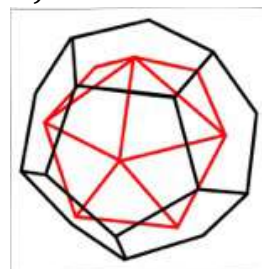

Dodecahedron-icosahedron

Layer	Octave	Energy potential (Octavian)= 1.24^n
1	128	907769738083
2	512	679051640990112193876920710485206529207942810790

When removing the potentials from only the 2 layer of the dodecahedral- icosahedral structure the reserves will last for hundreds of trillions years, that is, energetically the Control System is fully secured (that means that energy can be taken and used), and even if there is another "Great Explosion", it could be "seen from the Earth" (according to present day physicists). And if such knowledge provokes **GasPROM** or **RosPetrol** leaders infarct, it will only be welcomed.

The Earth Control System is engaged in energy distribution and providing chargers with necessary potentials. At its disposal there are specialised Control systems. It should be noted that the atomic structures have to be considered from the top down, that is **Highly Organized, strictly distributed in octaves: Plasma → Material structure (gas, liquid, solid body)**. An atom study in a solid body is a finite structure, and not the only one, as it is considered by the present physicists.

The results of the Program implementation.

1. The sequence of the creation of genotypes of the Brain and the introduced functions.

We consider only Complexes of the Caucasus, the Alps, and California.

Complexes of the Andes (the basic complex of the experimental support) and China Complex are considered separately.

Ararat Complex created the **FIRST** Brain genotype **421 in 1605 BC**.

Kazbek Complex created the Brain genotype – **422 in 822 BC**.

Elbrus Complex created the **genotype 423 in 00 AD**, completing the formation of **the first group, i.e. the genotype of the Brain 42**. The genotype of the Brain **423**, as more perfect, **WAS THE BASIS** for further development of possible additional executive functions of individuals of a higher administrative order and further improvement of the Brain genotypes.

In 1433, the first Brain genotype **441** was created (control complex of Alps 1).

In 1841 the first Brain genotype **442** (Alps 2) was created.

In 1990 the first Brain genotype **461** (California) was created.

While creating new functions for the individuals with the new Brain genotype new **MANTISSAS** were **INTRODUCED**, providing the execution of new, more complex functions. The change in the number of mantissas of the Brain genotypes, while introducing them, is shown in the table.

Nº	year	421	422	423	441	442	461	462	The object of energy supply
1	-1605	12	-	-	-	-	-	-	Jerusalem
2	-822	17	12	-	-	-	-	-	Samarkand
3	0	26	15	12	-	-	-	-	Byzantium
4	1433	28	22	18	12	-	-	-	Rome
5	1841	36	28	24	18	12	-	-	Paris
6	1990	36	28	28	24	18	12	-	Saint Petersburg
7	2009	36	32	32	28	24	18	12	Moscow

By 2012 it was SUPPOSED to BE completed the second cycle of formation, i.e., of all individuals of the second group with the genotype of **the Brain 46**. The first cycle was completed **in the year 0, but to be more exact – in 0000-01-17 at 02-11**.

2. Life support of genotypes in the process of their settlement.

In the process of formation of new mantissas, along with the capabilities of the Control Systems (the Caucasus, the Alps, and California) there were used limited territories of the "cupola" type that were created by

objects **440**. The borders of the frequency range generated by objects of type **440** formed a compact territory, which was the only **SETTLEMENT** of **NEW** genotypes in line with the object Program. Here is **an example**: the Hungarians were moved from the Urals to Europe, the attendance object flew there too, and there it "pressed" local "cupolas" without wars.

If you don't consider the artificial division of the borders, the formation of the places for genotypes settlement **WAS COMPLETED** in the **XVIII century**. After this there was provided an independent "opportunity" to demonstrate the advantages of the Brain genotypes over each other, **TEST THEMSELVES** and reveal weaknesses, as well as identify ways of "reconstruction" through the subsequent addition of mantissas. There were quite a lot of territorial claims clearing up at this period and, essentially, for no reason at all. It should be noted that **genotype 423** is a **VERSATILE BASIC FOUNDATION** for developing the whole range of mantissas and their further improvement; their actual code is **423xxx**, where "xxx" is functional and another kind of genotype. If the primary base for the formation of individuals of this Brain genotype was formed in Byzantium, its continuation in the future was worked out on the territories of the East of the Ukraine, parts of Russia, West of Belarus, parts of the Caucasus and East of Bulgaria

Territorial consolidation for the existence of individuals with the Brain genotype **423xxx** was provided with all the accompanying organized opportunities of the objects and systems to which mantissas of this genotype were adjusted in all their diversity. This applies to all questions of being, which will be **CALLED DEVELOPMENT** of civilization by scientists. In fact, it was a common programmed target process of the development of genotypes of the Brain and the fulfillment of everything that their being required.

3. The formation of reserves.

The entire quantity of different types of individuals for all the resulting genotypes of the Brain as many as they were formed, had to be **ATTENDED** and **PROVIDED** with all the complex of necessities for their existence. Not the exception but **SPECIAL ATTENTION** was paid to the support of the attaining the biological mechanism and providing appropriate nutrition. The Control System attended the digestion process and provisions in such a way that the **METABOLIC PROCESSES** corresponded to the installed mantissas for each genotype of the Brain.

In the countries of South-East Asia even spiders are used for food but their metabolic processes about **1.4 times** faster than the rest of the people, that is why spiders are eatable for them. But individuals with the genotype of the Brain **423** cannot eat them, for them "kebab" is more suitable. All attempts of the nutritionists to impose the results of some of "their own research" are aimed only at the destruction of that harmony, which **HAS NEVER BEEN** available in their brains, and is nothing more than farce, and business.



It was necessary not only just create the reserves of food, but to teach all the necessary technology to acquire reserves on their own – ***to learn to grow and make reserves of the required food for each individual according to the characteristics of their genotype of the Brain.*** It was necessary to check all the harmony of **ENERGYBIOGENESIS** of the **"SHIRT"** as a process of harmony with the introduced mantissas.

"An experimental ground" was set up under the Andes Control Complex. The local population had been input all the necessary experimental mantissas of all possible future genotypes of the Brain, and for centuries they had successfully experimented with sea food, animals and cereals, practicing tools, fishing gear and technology of growing and harvesting and stocking - up. Up to the present day, the major stocks of commercial fish are off the coast of Chile, and the population of Peru (Maya) as a result of experimental studies has ensured that **more than 90% of cereals** which they had grown

are used around the World today. It is interesting to know, that the cultivation of cereals was on **DIFFERENT** mountain **ALTITUDES**, *which corresponds to the different climatic conditions along the parallels on the Earth*. So, in the lower tiers there were grown tropical fruits, higher – grains, and further up – potatoes, and so on.

Modeling the surface of the Earth was on a fairly small area under the control of the Andes Complex. After completing the experiment all the *mantissas were removed from the population and the Maya settlements disappeared*. By the way, the first ramps were discovered in Ecuador, the first pyramid above the objects – in Peru, the Isthmus of Panama, in Mexico. And there is no need in **ANY LEGENDS** and excruciating "scientific" fantasies about the Mayan settlements. That was only laboratory work and nothing more.



4. *Formation and functions distribution.*

The main task of the Control System was the creation of such biostructures, the Brain of which **WOULD** fully **COMPLY** with all the Programmed set-ups of the System and be fully governable. In so doing the embodied governing of the entire individuals' being and the society's social organization had to be **ONLY IN the FORM** of a **PYRAMID** (because it was required by the imported basic foundation when constructing control information). I am saying it again that:

Level 1 – Moshiach (Allah, Buddha, etc.), the genotype of the Brain **481**.

Level 2 – "Golden million", the genotypes of the Brain **461, 462, 463, 464, 465, 466**.

Level 3 – "Golden billion", the genotypes of the Brain **441, 442**.

The "Golden million" are priests, finance managers, science and socium administration, as well as distribution of all kinds of material goods and services.

The "Golden billion" – production and replenishment of material goods, training and providing service staff.

The rest of the population was not required and **COULD HAVE BEEN ANNIHILATED**. But to annihilate a few billion people overnight is impossible. Or rather, possible (as, for example, dinosaurs in their time), but it would cause an ecological disaster. Therefore, the process of "annihilation" from generation to generation was "launched" over a hundred years ago, and it started with the "invention" of pills, vaccines, genetically modified food, and the like. And second – all the plans associated with the third World war from both the USA and the USSR, which are now becoming public are the plans for the **ANNIHILATION** and **REDUCTION** of the **POPULATION** of the Earth in accordance with the Programmed processes of Ebr Control System.

5. Consideration of the results.

Back to atomic structure.

The outer contour and tetrahedral connections are built using the rules of the Golden section. The Central cube, as the basis for the mantissas construction, was created by the interventional system using primes. However, with the explosion of Phaethon (the planet blew itself up along with those who were close by), there was **DESTROYED** the interventional archive of the primes **over octave 128**. It turned out to be the main **OBSTACLE** for the formation of the Brain (mantissas) of the following genotypes.

Let me remind you how the desired frequency is created. In order to create an individual with the genotype of the **brain 481**, there must be the Brain **NOT BELOW octave 512**, but the control of this Brain should not be below octave 533, and the beat must not be below octave 548. The calculations are omitted.

Rules of formation:

- find all primes in the range of 512-548 octaves;
- transfer all found Prime numbers to 8-and 12-th number system;
- select only those primes that have related ones;
- select from those numbers that have in 8-number system ending "777" and related "001", in 12th-system "BBB" and "001";
- add primary and related numbers;
- when decomposing the result, the number of quantizations is the octave, the number of "5" is the number of ties with Penta (the icosahedron) must not be more than 12. number "3" is not permitted when decomposing the series;
- the rest of the decomposition must be within the tabular value set only for material structures.

If there was a necessity to create new pyramids, they were created.

Let's recollect Pushkin – The Queen of Spades ("3"), 7, ACE (B/11).

Proceeding from an extensive range of numbers and the rules of allocation of frequencies, it should be noted that to solve this problem and reach the goal it will require trillions of years. **But the Earth Control System made a different decision – curtailing the existing Programs and the ELIMINATION of ALL the imported interventional waste, namely:** "to lose in the calendar the last 2000 years", to return to the state of **the 0 year of the New Era** and start formation of a different "Golden million". **But it has to be done only with the proper use of the Golden section.** In so doing, all the individuals created after 0 year, are transferred to **the state of 423 genotype (Control – Elbrus), and the genotypes 421, 422** will get the properties of primates in their DNA in accordance with Darwin's theory (by the way, the first individuals appeared among his friends) that you can clearly watch, especially on TV.

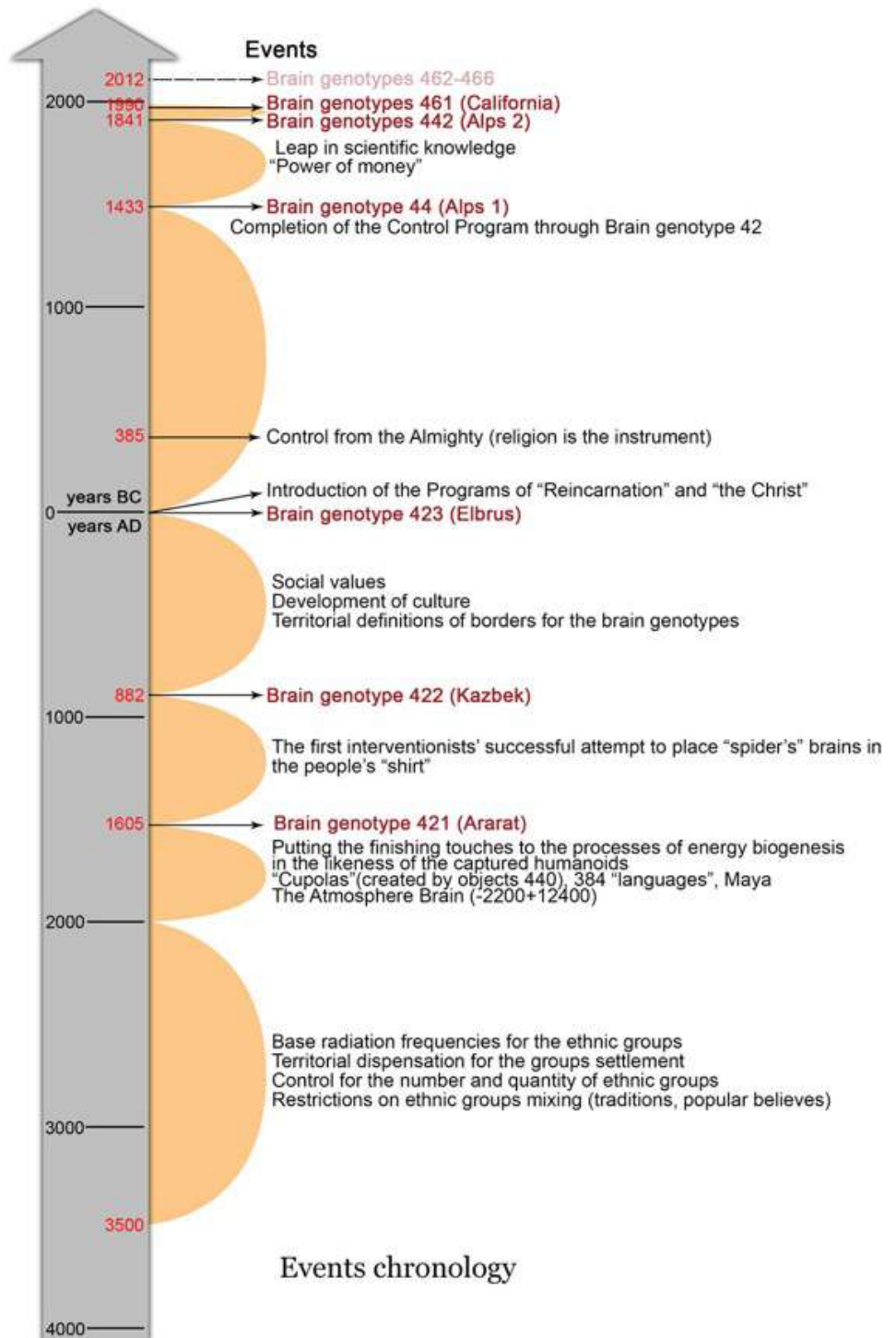

What will be changed with this transition in the former genotypes **421 and 422:**

- mantissas formation of lymph, bones, muscles are to be changed;
- mantissas of metabolic processes – sight, hearing, touch, smell are to be changed;
- mantissas of metabolic processes – breathing, processing of food, motor coordination are to be changed;
- mantissas of blood circulation and mantissas of the circulatory system are to be changed.

It is directly connected with full **UNPERCEPTION** of the reality changes of the environmental and habitat conditions. The number of "predictors" is growing like a snowball, especially in the Ukraine; they only speak with difficulty and inaudibly. However, there will not be any Apocalypse and coming of the "Antichrist". The tales have been ended. Here, in **NOT** that **EASY** situation, the main supporter is "**SvetL**" **Program**. But we should not forget our own **STRIVE FOR COGNITION**. Otherwise, the Program will provide a "comfortable" living out of your "shirt" and not more.

In the first place, the Brain (along with the bearer) of drug addicts, alcoholics and representatives of the criminal world is being destroyed. By the way, passion for money is recognized as one of the forms of drug addiction. As the authorities that are mandated to observe the concept of the Program, have taken the state of passive waiting, they will be replaced. Today the authorities' unwillingness to really clean up drug abuse, alcoholism, bribery, child molestation, ritual murder, and the like., are regarded as complicity.

6. ***Start of the new Program.***

The start of the new Program in its full aspect is to be implemented in **2020**. Now all the preparatory transient processes are in full swing. Until **2020** it is planned to significantly reduce the world's population. It **SHOULD** be taken **CALMLY**. The Moon will be withdrawn for 1,500,000 km from the Earth, all the satellites of the planets will be assembled around the Sun, the structure of the Sun is due to be changed and many other events are to take place... These processes for the last 10 years has been occurring before our eyes. Today, they are clearly visible.

3.2. Object 440 (Variant of the Alpine Complex)

Alps 1 and Alps 2 had their own objects of type 440, that differed from the objects of type 440 in the Complexes of the Urals, the Caucasus, Kailas and others.

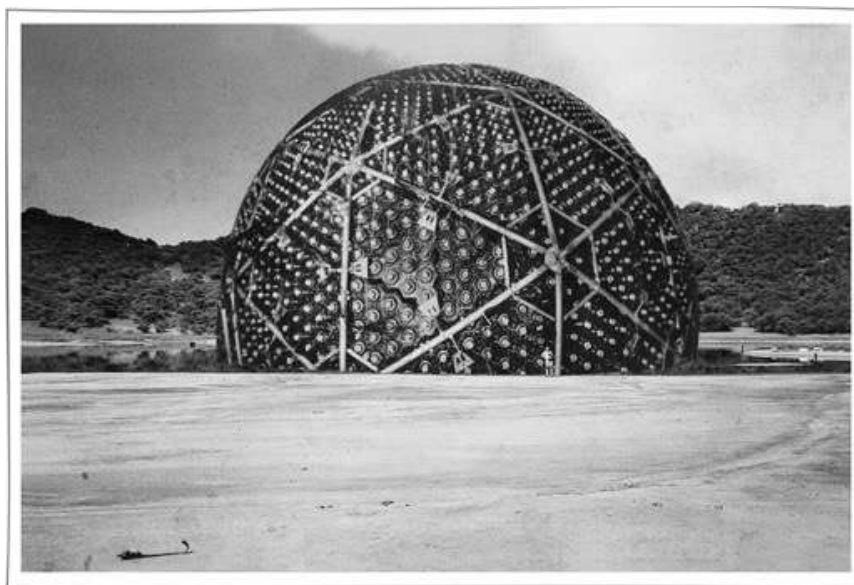

An object of type 440 has made a temporary landing

After appropriate transformations object 440 disappeared (optically it was longer visible). The object itself, as a plasmoid, went to the depth of 4350 m and was in the structure of the energy-information grating.

When receiving a command, the object raised for the execution of other input commands (including the use of the weapons). And now this object, as well as others will never go up. All the exit Programs have been disbanded.

The main characteristics of object 440 were (The Alpine variant):

The object had three separate system Generators (E-M-G): electric; gravity; magnetic (impulse shaper). The pilots did not have most of the structures, all the existing structures were minimized so that the transition from 31 to 57 octave was made without loss. The range of the laser system was dependent on the height (at the altitude of 2000 m it was possible to make destruction to the depth of 50 m). Protection rings had in their structure 2382 mantissas for all atomic structures (when a foreign action took place it was liquidated not only the object of action, but also the environment of the object).

No	Feature		From	To
1	Diameter in 31 oct. (max)	48 M		
2	Diameter in 57 oct. (max)	2,4 M		

3	Weight in 31 oct.			106kg
4	Weight in 57 oct.	-		
5	Landing depth (57 okt.)			4350 m
6	Lift height 57 in oct.			12400 m
7	Lift height in 31 oct.			4800 m
8	Flight range, km.			8500 km
9	The number of protection rings(1*)	4		
10	The number of pilots	12		
11	The number of laser systems	6		
	Range			6,4 km
12	Electric power	1046 watt		
13	Change of gravity, m/sec ²		-12,4	12,4
14	Transit time in 31 oct.			2 sec
15	Transition time in 57 oct.			7,2 sec
16	The processing area			12 km ²
17	Material 31 Oct.	Os187		
18	The number of mantissas in 57oct.	666		
19	The number of mantissas in 31 oct.	248124		
20	Passengers number in 31 oct.			884
21	Passengers number in 57 oct.			44
22	Command language	Russian		
23	The number of generators	6		

The Mother-ship (transport base) for **ALL OBJECTS** of type 440 was the Moon. At the Moon-Earth connection a **TEMPORARY TUBE** was created, through which the plasmoids in 57 octave arrived in the Earth.

On the Earth before the objects landing there had been prepared not only landing sites, but also storage space, and energy-information channels had been laid out. **Energy-information channels** linked each object with the corresponding Complex, with the Control System, with the Complexes Control System, and with **PUMP-UP CENTRES** (like Bermuda, for example).

Taking into account that all the objects of type 440 were continental-based, the transitional processes were more complex than those of the sea basing objects.

Objects of type 440 had four kinds of their state transformations

A) 31 ↔ 57 taking off and landing.

B) 31 ↔ 57 cleaning out the area (all modern deserts are the traces of the **FORMER CIVILIZATION** annihilated during the invasion).

C) 31 ↔ 57 flights to the Moon and back.

D) 31 ↔ 57 passengers transfer.

Additional features of the objects of type 440 were:

№	Computers	Features
1	Number of Computers	12
2	Used gas to clear indications	Xenon
3	Elementary memory cell	The Star of David (12-6-3 number system) *
4	Word size	6
5	Size of the text's cell	144
6	Beat period –reception -transmission	0,0555 sec.
7	Reception- transmission table	12*12
8	The process data time (calculations)	124 tera Herts
9	Method of information storage	Optical, on 59 octave
10	Memory capacity of a computer	484 tera David
11	Number of language translators	336
12	Screen stop-frame (outward) 1*4 м	0,036 sec.

Information on the computers objects came:

- from the Control System (12 number system);
- from other objects (6 number system);
- from Biostructures 42, 44 of the Brain genotype (3 number system).

Regardless of the number system, the received information in coded form was stored in one memory cell and then was transferred to the processing in 8 (octal) number system, that is the type of the Star of David, kept the information in 4 number systems simultaneously. In the 57 octave the computer worked in the automatic mode, and in the 31 octave pilots **USED** the **INFORMATION** processed on the computer.

Objects of type 440 had their own Generators for octaves 67-127, as well as their own **SYNCHRONIZATION** of **BEAT** time, which is important for all the octaves of this range. In addition, they had their own calendar and their Program (which was turned in case of the incorrect use of the general Program). For each period of time the object had 6 emergency programs and, in such a case, the object made a take off and an initiatory correction of the External Program.

What was the emerge mode and the sequence of actions of the object? If you are interested, you can find it in the writings (calculations) of **A. Khatybov**.

The pipe for the object's type 440 exit is a **CHANNEL** of **PLASMA**, so the external contour of the object at the exit (entrance) had protection in the form of plasma indestructible ball. After completing the transmutation in compliance with the program the object used the E-M-G Generators (Electro-Magnetic-Gravity) with the private reserve of electric potential.

3.3. Cluster System of the Control

The old Structure of the organized life of people in all spheres of their lifestyle at all stages of social and civilizational development **is the Super-Kluster System**. It was **IMPOSED** from the **OUTSIDE** by interventional interference in order to get the "complete" governing and provide the state of all round control over all the processes associated with the execution participation of people under the conditions of their **CONSUMER GOODS APPLICATION** while carrying out two basic interventional Programs of Ebr System – **"the Development of the Brain genotypes" and the "Development of Energybiogenesis of the flesh cell"**.

All the versatility of such control covering, including all the gradually evolving spheres of life, preventively matching all of this with the energy-information translation of the cognitive and control character on the side of The Control Complexes (the Caucasus, the Alps and California) involving the execution participation of people – all of this was perceived by them (i.e. by people) as a "natural" process of civilization development. The entire Old Structure of the organized being was represented by separate clusters of the preformed structures of all spheres of people's communities being, geographically located and distinguished by the specific Programs of their development, under the strict guiding of the old interventional Control System.

The former Structure, as a Super Cluster System suffered a historic collapse, starting with the elimination of energy-information translation from the Control Complexes of the old System. The principal Control Programs were eliminated in 1985.10.25 (simultaneous earthquake in Israel, Italy and Australia – the servers elimination, Programs depositories). In this regard, its further existence is very short-lived. But in the current time processes – it is also an atavism of the alien to the Earth and Human "civilization", which is being ELIMINATED by the new (being recreated original) Control System. But this does not mean that such a process has been let matters drift, without a concrete expression in time. You may remember that there was an opinion of the "visionaries" who persistently created panic fear among the people "predicting" Apocalypse; and professionals who stated that such a TRAGIC ACCOMPLISHMENT had been targeted for the end of 2012. HAD the old interventional Control System NOT

BEEN liquidated, then with high probability this might have happened as the programmed process of the former control from the outside. But since 2011.04.24 (the change of the "System Power") all the processes of the clustered arrangement in the former organized being structure, understood as processes of "social development", have been subjected to fundamental correction within the Transition period. **The primary signs of this have already been accomplished and are perceptible in the form of irreversible obvious crises in all spheres of people's being.**

Why?

Before answering this question, you have to understand what is meant by the notion of **cluster superimpose on the processes of social development**. Is such a judgment correct when studying the processes of social development? Has **CLUSTER ARRANGEMENT** in the construction of the controlled life of people's being taken place in general? What does the term "cluster" include in relation to the processes of people's being?

Cluster (Eng. Cluster – congestion) is a union of several homogeneous elements, which can be considered as an independent unit with certain characteristics that are common for each associated element. Such understanding of a cluster when considering the system of formations is used rather widely both in studies of the microcosm and macrocosm scale. At the moment we are only interested in the cluster systems of the structural elements that directly affect people's being and everything that is associated with this process.

Regarding scientific aspects of the so-called Stellar mechanics and the knowledge concerning guiding system associations in the frame of civilizations development as processes of the programmed being this concept of cluster is also acceptable. With the concepts of some of them we will have to cross over.

The celestial cluster (congestion of stars)

This is a group of stars, on the one hand, connected by the tubes (gravitational, informational, and others), representing a specific model structure of guided energies being within the imposed strictly identified range of energies octaves. On the other hand, such a group represents a single programmed – control process of its civilization development, in

which each element of the complete (a particular star or group of them) **IS IMPOSED UPON** with certain **FUNCTIONS** that are complementary or ensuring harmonious existence of the whole cluster. It is an embodiment of the specified and controlled civilization development or other programmed role and application in cluster systems of a higher order.

The Galactic cluster

This is an independent superstructure, which is a certain set model structure of several Galaxies. As a super cluster, it has a **SINGLE** programmed functional **EMPOWERMENT** and a unified system of governing, control and attendance of the complex civilization development of each complete of galaxy, the system of formation and harmonious distribution of the whole limit of the imposed energies octaves in their both material and immaterial conditions. The Galactic cluster, like a design, has a multi-level complicated structure of connection tubes between galaxies and celestial clusters in each galaxy.



The civilization cluster

This is a group of civilizations with a single programmed functional empowerment for the period of a particular stage of the governing civilization development. Unlike other cluster systems, each civilization cluster is represented by a model of a well-defined number of stars (planets), unified by a single system of the programmed civilization development, as a structure of studying character. The uniting of all complete constituents

(planets) is due to the formation of only the connection tubes (governing and control), through which the governing process of stage by stage civilization development is carried out as it is. In fact, it is the embodiment of the part of the process of quite specific programmed harmonic control according to the orientation of civilization development on a global scale. If in a simple way to express a kind of cluster similarity of the gradual civilization development, acceptable to discuss in a secular surroundings, such similarity can be compared with the **GRADUAL EDUCATIONAL** development of people, namely: primary education, secondary, higher education, further qualification and the development of their professional excellence and improvement of their cognitive level. Each individual stage of civilization development is a very specific stage in time to engage a set of strongly-identified (designed by the program, i.e. functionally endowed) Planets for the temporary systematic cluster association for the passing (the assigned planets) their indispensable civilization development.

The determinative indicator in achieving results of such civilization development in each stage is the achievement of **HARMONY** of energies **BEING** in their material (inertial) and non-material (non-inertial) state in all the range of octaves of the planet's (group of planets) energy model, imposed upon them for this **SPECIFIC PERIOD**. For the planets of Intelligible orientation the absolute measure of perfection is also achieving the desired (preset) level of development of the Planet's Mind for this stage of development. Not superfluous is to remind that, with respect to the Earth the development of the Mind of the Mankind (not the society of people) – ***is a part of the developing Mind of the Planet.***

With regard to the modeling complex of the Earth, the initial phase of its first stage of civilization development was getting its perfection under guardianship control on the side of the **Civilization Cluster of "Orion" group of Civilizations** (the phase of "preschool education"), ***which includes 384 Civilizations (the number of "vacancies")***. The subsequent phase of its first stage of the Earth civilization development would have been under guardianship of the **Civilization Cluster of "Sirius" group of Civilizations which was to unite 784 civilizations (currently 783 due to the lack of one "pupil" in this cluster – the Earth)**. But in the time of the events of the transition state of guardianship from "Orion" group of civilizations to "Sirius" group of civilizations (as the most unstable and poorly protected transition time to control the Earth from

outside) **there was an interventional interference of the DYING Ebr civilization CLUSTER, with no prospects of its development .**

Since that moment (almost 18000 years ago) the process of civilization development of the Earth itself has **LOST** its goal-oriented and governing **INDEPENDANCE**.

This is a superficial explanation of why and under what circumstances the intervention took place, and how it all could have happened. **For the Universe scale 18,000 years is an INSIGNIFICANT VALUE** of time, but, nevertheless, in the time of the events all the processes of recreation will be corrected by the compensation for such loss of time in the pace of civilization development.

At present, i.e. after the change of the System of power (**2011.04.24**) and the **COMPLETE DESTRUCTION** of all the imposed programmed processes of the interventional control on the side of the external Cluster of Ebr Control System, the **MOST COMPLEX** systemic **TRANSFORMATIONS** have been taking place on the Earth. **These transformations are strictly oriented and connected with the liquidation of the consequences of the interventional interference and leading all control states as well as the Structures of the CONTROL of energy BEING to the level that our Planet had had at the time of the state of leaving the guardianship of "Orion" group of civilizations.**

As soon as the reconstruction of previous states of energies (in their inertial and non-inertial constructive form) are completed the true Earth Control Complexes will be restored, and also recreation of the previous levels of the control of the entire energies being will be completed – the Earth will move into the second phase of the first stage of its civilization development, i.e. will be placed under the guardianship of **"Sirius" group of civilizations. By this point there have to be recreated all the former environment and habitat on the Planet, got (restored) the states of controllability of the changed environment, recreated the Man himself with a new level of higher octaves, and also brought to harmony with the general changes the Design of the organized being – THE HUMANITY**, and many other drastic changes, including flora, fauna, water, etc. Exactly this way there will be recreated **THE TRUE CLUSTER** of the complete state of the Earth civilization development control which it had possessed at the exit from "Orion" group of civilizations. And only then there will be possible and allowed "From the

Above" the real transition to another subsequent level of the civilization development of our Planet.

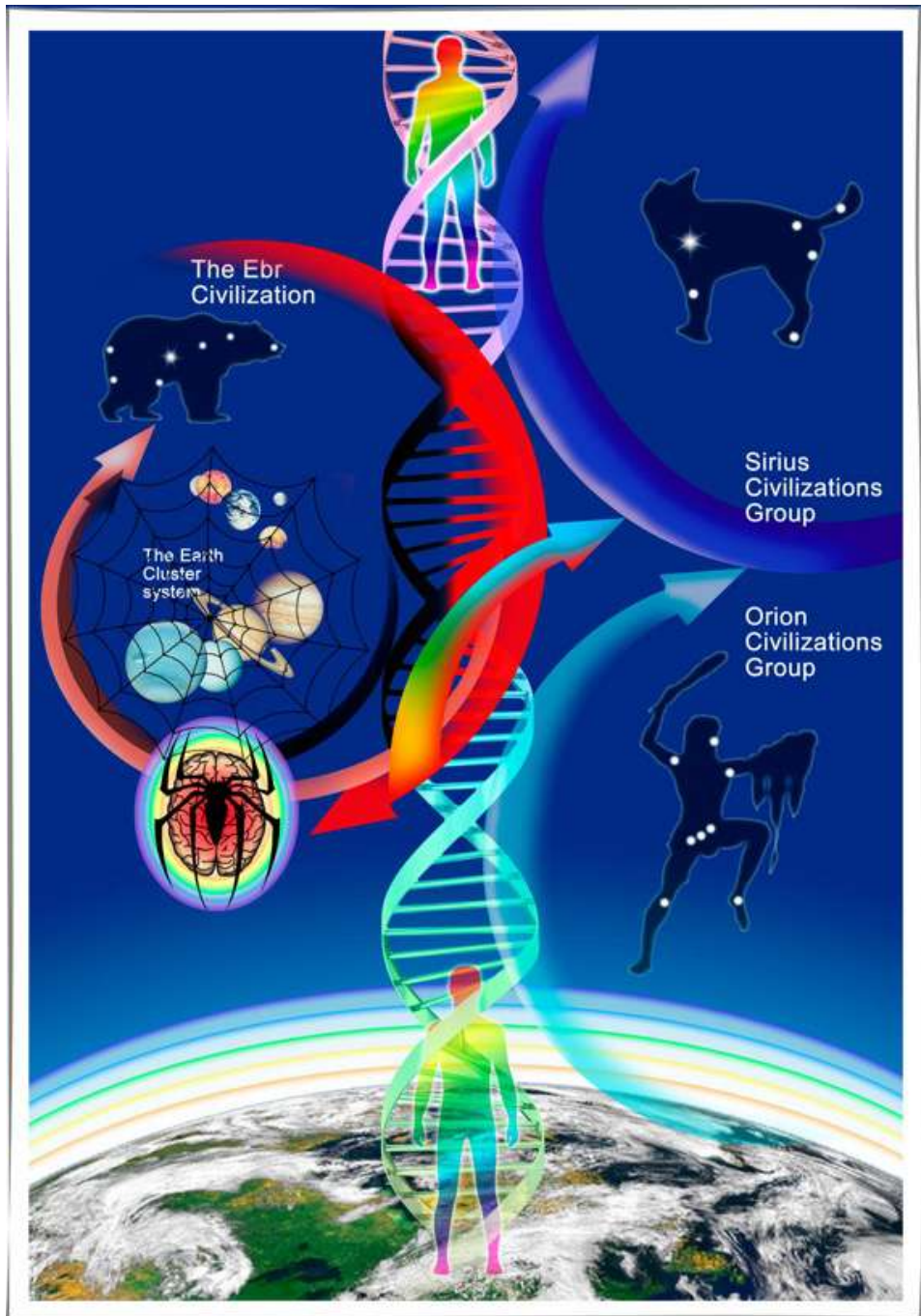

The Planetary cluster

This rigorous model Design of **a SINGLE PLANET**, is represented by a complex of energy gratings of the entire range of energies in their material and non-material relatively stable conditions. Such a Design is shaped to give a harmonious guided being, and to provide the necessary programmed indispensability in the process of the embodiment of the current stage of civilization development. A model cluster design must have a System Complex of the autonomous control, which **would be capable of:**

- ensuring the implementation of the Planet's functional endowment at every stage of its civilization development;
- organizing, governing and controlling the harmonious existence of all the imposed range of the octaves energies at every stage; directing the entire process of its development within the framework of the inserted Vector of target, phenomena, actions and events, as well as adhering to the time beat in its own and general chronicle of events of the system clusters of a higher order.

Planetary clusters having (endowed with) living conditions, additionally have Systems to control the most complex process of the composite conditions of the life support, rigorously monitoring and ensuring the harmony of being of all the imposed diversity of living individuals (entities) and distinguished forms of tangible and intangible coexistence. For all that, all sorts of state of hegemonic parasitism of one over the others or quantitative beyond the programmed (uncontrolled) prevalence exceeding the level of the programmed mutual sufficiency, are corrected through the Control Systems and eliminated to the level of necessary sufficiency.

Planetary clusters, with further vesting in the development of civilization of Intelligible orientation, have in their control System: control Complexes, objects, Systems energy information translation and communication, which all together ensure the formation and retention in the stable state the **ENERGIES** of **CONTROL** – the **MIND**. The Mind as the highest constructive state of the specific control energies takes the form of a very specific "energies-substance", which, in turn, has the property to develop up to those controlled limits, which were according to the **PROGRAM SET IN ADVANCE** to the Planet while imposing it with a specific function.

On achieving complete harmony of all the states of energies, within the imposed octaves and gaining a level of the Mind development, reaching the

designated limits, and ***keeping the Mind substance in a stable condition***, the Planet is transferred to the next stage of its civilization programmed development. **For all that a new, higher level of energy octaves in their immaterial and material states are imposed.**

The cluster of social development

Many representatives of social sciences correlating their world outlook only with dialectical materialism present the process of social development as self- initiated manifestation of the society's civilizational development, subordinate to certain ("invented" their own classics) mandatory laws. They also present with confidence the fact of **RANDOM ASSEMBLENESS** of the **SOCIETY**, according to the will and desire of the parties, as a "natural substance" and only to "meet the requirements caused by nature" in the process of the forced joint cohabitation. ***In order to justify the very existence of such a forced "natural substance", and in addition being embodied in the regularities dictated by them, concealing the true reasons of the imposed violence and the entire social restrictions of the overwhelming majority by the insignificant minority, they put forward a number of "indestructible theories", which were positioned on their side as "perfect" and with certainty in time, for not less than "all future ages," i.e., forever.*** The truth is that all the fabrications of a sort of "political wise men" **SUDDENLY COLLAPSED**. They are no longer able to fabricate other theories, and as for the future- they are not even able to formulate it. Is it loss of vision in an uncertain "bright future" or clouding "of the mind and the eyes"? The Control of such a complex programmed process is performed with the help of the forming Cluster of social development. But it should be preventively declared that the indicated Cluster **HAS NOT TO BE CONFUSED** with the state apparatus and all its instruments of violence, as they have been mixed up into a single concept by the current and previous social scientists. What does it represent, what are its main functions?

Eventually, the Cluster of social development, in contrast to the claims of social scientists of the past, is a COLLEGIATE STRUCTURE of the systems control from the outside on the part of the Control Complexes and their servers. Its main goal is the ***formation of the current state of social consciousness*** and continuous monitoring of the level of its states by imposing energy-information translation for the formation of future specific executive

people's actions and preparing the programmed set of events with their participation.

The cluster of social development "formed and stipulated" the **ENTIRE SET** of executive states in the midst of the people's society **through their social consciousness** and was the shaper of the society's "perceived" thoughts to further control of them by the Cluster of the state control. As you can see, it's not the same thing. Moreover, their functions are completely differentiated, but mutually harmonious by their controlled embodiment.

The Cluster of state control.

It, at this historical moment, is of the greatest interest, as it is that very **Structure of the controlled organized people's being**. The Control is still carried out unattended, as external (i.e., from outside, by the interventional Control System in the past) as well as the internal control through the organized "instruments of state violence."

The structure of the Cluster of state control under the old Control System was based primarily on:

- the programmed current target Vector of future phenomena, actions and events corresponding to the time of events of the chronicle process;
- the imposed targets of every stage of the executive actions of people to implement **TWO STRATEGIC PROGRAMS** (**the Development of the Brain genotypes and the Development of Energybiogenesis of the flesh cell**);
- strictly expressed Structure of the imposed (on the side of the Control System) hierarchy of the social control of the public development according to the degree of relative "controllability and importance" of all individuals, with regard to the **SPECIFICALLY** expressed genotype of each Brain as a common (state) model of the executive actions of people illusively **IMAGINING** as a society for "cohabitation" in it to meet the emerging social, spiritual and other everyday needs and other things less important.

The control of every sphere of being, as separately expressed elements of much lower order in the overall Structure of the of people's being, was also **EXPRESSED BY QUITE SPECIFIC SUBJECT FUNCTIONAL CLUSTERS**.

Returning to the consideration of the Planetary cluster, I would like to emphasize that the harmonious being of all the range of the imposed

energies octaves at each stage of the civilization development of the Planet must **STRICTLY CORRESPOND** to the beat time in their own and general event of the chronicle process of the systems clusters of much higher order. In the process of the interventional interference Ebr System **HAS CHANGED** the **BEAT** time, and imposed its standard of charge fluctuations on the sides of energy gratings, equal to standard =1,0007 sec. in relation to which there was imposed time model 60x60x24 with all relevant time-bindings, including the Earth's rotation around its axis. This standard beat of fluctuations, as if the **IMPOSED TIME**, was provided and assigned by the charges fluctuations along the sides of the **energy gratings of Cs 137 (lat. Caesium)**.

And now is the MAIN thing that can be said TODAY:

- **In 2012.12.24 at 0115hrs** the control and fluctuations beat (1,0007 sec.) of the old Control System is **TURVED OFF** (the Stonehenge Complex);

- **In 2012.12.25 at 01.15** The **NEW CONTROL** and support of the fluctuations beat (1,008 sec.) is **TURVED ON** which is the **TRUE** and **RECREATED TIME** of the Earth in its first stage of civilization development. Turning on was carried out by the recovering **ALTAY Control Complex**.

This process corresponded to a particular relative position of the objects of all "parade of Planets". Exactly at this moment on all the Planets of the "parade of Planets" **there was restoration of their true standards of beat time**. Exactly for this reason, the "Mayan Calendar" terminated with respect to such Universal event.

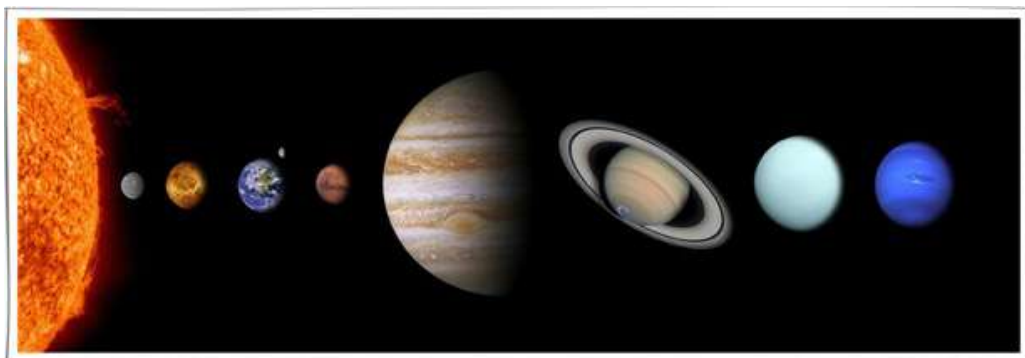

Exactly because of this there **WILL NOT BE** any Apocalypse!

With this landmark event there began an active phase of many processes for the **RECREATION OF ALL OCTAVES** of the energies on all

the Planets ("parade of Planets") in their true state. Here I would like to add only one thing – exactly because of this it was carried out the reprogramming the **Generator** of "Dark matter" (in the terminology of **N. Levashov**) through the newly created **Program "SvetL"** in relation to the new standard of beat time. And this **FUNDAMENTALLY CHANGED** the purpose of the Generator, making primary the Brain development with reference of this process to the System of control and life support and on this background – health improvement of **the Programs "SvetL"** users.

3.4. About the creation of the "Shirt", failure of Intruders and of the collateral...

The animal world, the insects were created to control the Man frequencies.

In the atmosphere structure ($-4400 < h < 12400$ m) there is oxygen, hydrogen, industrial emissions, and **OTHER FORMATIONS**. ***There are also biological structures both in material (inertial mass) and immaterial (non-inertial mass) states.*** Biological structures in the material state are described by "scientists" in detail– they are divided into classes, groups, genotypes. They all have distinctive features, which make it possible to determine their ancestry. There are some signs In humans, too, – whether they are relevant to the class of apes, or created by the aliens. As a rule the interference of the aliens is being denied.

Intangible (immaterial) biostructures were represented with two types.

The first type is represented with all types of visual delusion, ghosts, hobgoblins, and others which the civilized world has been faced with at every step.

The second type are humanoids from small insects to humans. In the state of a humanoid one IS **ABLE TO BE** for thousands of years until conditions are created for materialization. All humanoids, as a rule, were subjected to reincarnation.

An example: If you "slapped" a mosquito, it does not mean that you have destroyed it. You altered the material structure of a mosquito but it also has a structure in 77 octave, in ininertial (immaterial) state, and its new materialization can happen in a day. Modern science is only guesses about

it. **MATERIALIZATION** of **USEFUL** for the Mankind, insects: locust, bedbugs, lice, spiders and others, was performed by the Invaders Control System only in the event of an additional control over the frequencies of these insects.



The inconveniences for the invaders began after they had decided to use the Shirts that remained after the **INVASION** and **ANNIHILATION** of everything and everyone. **Firstly**, it was impossible to reproduce in Shirts, as high frequency octaves were destroyed (or rather, reduced to 2-3%).

Then urgently they had to introduce "support", but there arose a problem with the "reproduction" organ. **And immediately a "national custom" was introduced – to cut off the excess.** Then it was noticed that in the course of the control, not all can be verified. It became necessary to burn sulfur, which was subsequently replaced by candles. There was also a number of trivial inconveniences, which were later transferred to religious cults. But still, to **CONTROL** the **FREQUENCIES** of octaves **65, 67, 71** mosquitoes, bedbugs, fleas and other useful insects were developed.



If the frequencies that were considered unnecessary were removed from the Noosphere, then the systems of biosensors were removed as well. And to monitor the new state there were created new biosensors, either in the existing ones new functions were added. I want to note that the term "web" **REFERED** specifically to the **CONCEPT** of "a spider", **and it was one of the 18 structures of the Control Systems**. The Brain was created for the web, and it (the brain) could "pick off" and process the information that was necessary to the Control System of exactly this structure.

All biological structures, including Man, were designed in such a way that had a whole set of octaves **from 16 to 128**. They are different in purpose, and the dominance of a particular group of octaves formed the basis of a biological structures.

Functional division into octaves:

- **16-32** = all kinds of gases and water (breathing and water are necessary for all);
- **34-46** = structure of reincarnation (all structures sought to the potentials of frequencies of these octaves);
- **48** = distributor;
- **50-52** = energy balance;
- **56-62** = organs control;
- **64** = material structures;
- **66-72** = brain;
- **74-86** = reincarnation control;
- **96-126** = control;
- **128** = defining beat generator

The Program "SvetL" until recently "worked" in the range of **66-72** octaves (for interoperability with the Brain of the owner). Today, the range of octaves of **"SvetL" Programs** is expanded to **128**, which makes it possible to "interact" with the defining beat Generator. It is extremely important in the processes of changing the Human life support System. We can say that the first step has been made in the implementation of **life prolongation up to 124 years**. But this does not mean that being a member of the **Programs "SvetL"** you automatically become a "long-liver". **TO THE BATH** you will have to **GO**. And, as **N. Levashov** used to say, – It is quite "another hiZtory..." I got this understanding a year later, after **Nickolay's** "passing away". Before the **INTRODUCTION** of the **CHANGES** to the **Programs** it had been necessary to periodically make

recommendations on the Complexes "reset" so that the Programs "reacted" and "adapted" to the changes occurring in the life-support System. Now this problem is solved. And it is solved thanks to the knowledge obtained through studying those works by **A. Khatybov**, which even today are **NOT PUBLIC**.

All kinds of plants, herbs are of **34-44 octaves frequency**, so the cows eat (as I have mentioned), only grass, knowing that they will be used as meat. Apparently, therefore, in India – the birthplace of the reincarnation theory, – cows **ARE SACRED ANIMALS**.

For dogs it is important to know that reincarnation exists for them (frequency range of octaves – 78-80, combined with the frequencies of octave 64, but these are bones). The dispersion of the higher octaves is fairly slow, and if a person dies with the potentials of bone frequencies above 122%, then even after 1000 years those bones can be applied to the sore spot. It's about the phenomenon of "Holy relics".

Earlier I wrote that all metabolic processes are **CONTROLLED** by the **BRAIN**, but the distributor of "the goods" for the cells of the body **IS** the **HEART**.

All believe that mental activity is the Brain's function. Earlier I wrote that all metabolic processes are **CONTROLLED** by the **BRAIN**, but the distributor of "the goods" for the cells of the body **IS** the **HEART**.

However, even in the Yeltsin time (I then worked in the North-West region), on all the posters it was written: "**Think with your heart!**" And if you look a little deeper with humor and irony of A. Khatybov, then before getting the Brain the thought center was the Heart, and before that – **TWO HEMISPHERES** below the spine. Having three centers for the reproduction of thoughts, there is a possibility to have vacations so that it would be imperceptible what structure is running the body today. Of course, the main Brain has a maximum size. The thought process is, naturally, divided. Incidentally, all three intellectual structures roughly have similar design – they are divided into left and right halves. The brain is conservative and unresponsive to external changes. The heart and especially the lower brain, are keenly interested in all the changes, and their form depends on the advertisements in the media. There is such a concept as "bull's heart", it is the pleasure of beer consumption.

The Brain (cerebrum) – has a lot of convolutions, works only for itself – where to steal and whom to cheat. The Heart has no convolutions,

but makes principal decisions and **DOES NOT REMEMBER ANYTHING**. The lower Brain is equipped with a single convolution, makes all foreign (state) decisions. It is especially evident today. The amount of pleasure for the lower Brain is enormous, because it is the leader in all new beginnings.

Of course, paying for the consequences of the Brain's work and, especially, the intellectual conclusions of the Heart, has always to be done by the lower Brain. It is administered various pharmaceutical preparations (injections), rods, whips, hunting rifles are developed for it. If there is a necessity to correct the thought, salt is used to increase the pH (negative logarithm of the hydrogen ions concentration in solution). A charge of salt has a beneficial effect on the correction of the decisions made.

If we make a trepanation of a cockroach's head portion of the body (instead of the Brain, according to our traditional concepts and approaches), we will not be able to detect the Brain; instead, we will find something that **HAS NOTHIG TO DO** with our concepts of the Brain. We discover one hair

in each "half" of the skull with "poppy" seed upon their tip. We naturally come to the conclusion that the cockroach has no Brain and this will be our "mistake" since the Brain of the cockroach is *mostly in immaterial*

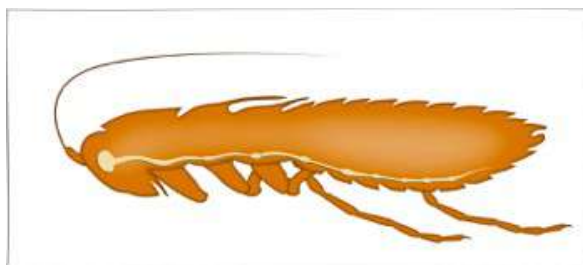

(non-inertial) state and its Brain is quite enough for the execution of its functional vesting, granted to it by the earlier interventional System as an appendix element of the System of biological control! But its Brain is not that simple, moreover, it was able to perform quite complex operations to **GATHER INFORMATION** of the biological environment state according to the parameters that were required by the Program "**Development of Energybiogenesis of the flesh cell**", i.e. people! Thus, the Brain of a cockroach, as the **MINICLUSTER SYSTEM**, professionally controlled all Executive actions of this **IMPORTED ENTITY**, played an important and specific minor role in the biocontrol System. Here it is such a monster, that cockroach.

So what is the Brain? The brain is a cluster system formation of the energies that are in inertial and non- inertial states created for specific operations of control, monitoring

analysis and having the property of improving in certain permitted limits, under the control of a higher level of formation.

As for the Brain of the Control System as a very specific cluster of the control systemic formation in the most complex structural embodiment, people's perception of it, its constructive arranging, functions, technical and technological capabilities, and much more – are **IMPOSSIBLE** within the framework of traditional ideas of the Brain, especially when making restricted attempts to compare it with one's likeness as a perfection of nature! By the way, specially distinctive (not for merit) signs of the human Brain as sight, speech, hearing, smell, and other gained "perfection" (obviously, not without the help of Darwin and his kin) are also available in the Brain of the Control System, but are in incomparably high and perfect condition.

The earth as an artificial structure has been created for about 7 billion years. At present, there is the following in operation on the Earth:

1	The Control System (CS)
2	7 Secondary control systems (SCS) – servers having more than a 1000 pyramids (each), hundreds of terminals
3	Objects (more than 3500) for the control and reconstructions
4	2 colliders (under the North and South Polar circles), define the beat = 1,0007 seconds
5	8640000 meridians
6	7 cords to read the information
7	More than 1 billion biosensors
8	Beat time Control System
9	Control System of the Earth surface
10	Near Space Control System

It all works as a unified system in which Man lives. But today the **PROCESSES** are **UNDER WAY** that affect and have a significant influence on virtually everything listed in the table.

Many people know that Man has "Chinese points" (Pfall points) – they are the points to control and influence Human organs by homeopathic effects with needles, shock, etc. It is considered that if to stick needles (gold, silver, platinum) in the "Chinese points" then some good individuals (spirits) will run at full speed and locate themselves in the right places, and the evil ones will run away.



But it is accepted to believe so that **NO ONE WOULD THINK** another way. Each of the SCS (Secondary Control System) forms its control cord, and it takes the control cord 2 hours and 10 minutes to make a complete control of the environment, making a full turn around the Earth. The information collected allows the SCS units within a few hours to make a **CORRECTION** of the **ENVIRONMENT** from -2200 m to +12400 m, creating the ideal conditions for Human existence and for those who he is going to eat! However, to pick up the information from one man within one examination, in principle, is impossible. So, SCS Kailas for the Brain control withdraws **PART** of **the BRAIN** for a long period and makes a comparative analysis with the given program. This time a Man is asleep. While being controlled a man is watching a "new video", taking it for a dream. The rest of the SCS could not afford to have unlimited time to collect and analyze the information, therefore it was created a unique method. Each frequency available in a Man, was copied to the extraneous biostructure, and with the passage of the cord this biostructure in resonance mode responded to the request. Thus, billions of biostructures gave (each one) in the resonance mode the information on the state of man's health in the control environment. It's hard to compare it with the current level of our knowledge, but it was exactly so. There were no **ACCIDENTAL BIOSTRUCTURES** on the Earth. Each of them was supported basing on the program requirements. Raising the level of the Human Brain required the **REMOVAL** of **OLD** bio-structures and **CREATION** of **NEW ONES** that, in fact, is observed nowadays. There is an example of it; some time ago, the US was subjected to mosquitoes attack. The scientists reported that the drug was produced after eating of which mosquito's stomach was destroyed, and the mosquito died in painful convulsions.

Having asked some known Russian biologists about the structure of the mosquito, it was found out that a mosquito as a highly developed being has **NOT ONLY** a stomach but all that is necessary for normal processing any food (approximately, as in the case when the single-cellular nibbles the multicellular, having protection from them). The information on the success of U.S. scientists was broadcast by all the media and no one but A. Khatybov (for some reason), had any questions. **The first thing** that Alexander Mikhailovich paid attention to was –what was the mosquito eating?

In the dead blood erythrocytes, as the sedimentary structures have a diameter of 7-9 microns, and living blood – much less due to the difference in octaves, although medicine still thinks the erythrocyte stretches in the likeness of the sausage and squeezes through the narrow capillary, with the moral support of the heart contraction. The mosquito does not need either the blood plasma or other structures. What did he eat? The mosquito is only interested in the erythrocyte **WITHOUT the MEMBRANE** and without the address "lable", i.e. an erythrocyte in the **STATE of PLASMA** (like the oil spill in the sea). In medicine it is "sugar" in the blood, or diabetes. Such an erythrocyte **HAS NO** connection with the control structures and has to be immediately removed from the blood system. This erythrocyte has 12 form frequencies (does not fall apart to atoms). The plasma state of the erythrocyte is a **SERIOUS VIOLATION** in the functioning of the kidneys, liver, pancreas, but to control them **AT THE SAME TIME** is **IMPOSSIBLE**, and therefore the structure of a mosquito was created, that recognized only a group of **12 frequencies** and reported their availability.

With the cord moving the information on the presence of the plasma state of the erythrocyte was recorded and later analyzed for decision-making. If the information wasn't enough, the mosquito population was increased. The mosquito can be compared with the "Junkers-87" – when approaching the target the siren is turned on. The mosquito's siren was turned on automatically, and the farther from the body it turned on, the more erythrocytes were in the plasma state in humans. Blood has plasma and **pH=6,88-7,45**. Если **pH>7,45**, then compact sensors were created – **mites and bedbugs (for pH<6,88)**, which had only 4 resonance frequencies (without a siren). In any case, they first tasted the plasma, and if it didn't fit the norm they left the information for the cord. Also, as with mosquitoes, if the information was not enough, the population of bed bugs or mites was dramatically increased.



To generate **genotype 46** there were no special problems with red blood cells and blood plasma. The main problem was the support for the erythrocytes production. It was necessary to create a deficit of erythrocyte by their seizure. For this purpose leeches were used. Russia, before 1917, had exported **60 million leeches a year**. Only in St. Petersburg 8-

12 thousand peasants worked in this field. The exports went to Europe.

Nowadays, the erythrocytes in the plasma state are poison for leeches, that is why A. Khatybov, as always, in his favorite manner advised treating with bedbugs first, then mosquito (must be sterile and seamed in a jar) and only after the elimination of plasma erythrocytes leeches can be allowed. Of course, the civilized mankind was obliged to keep in the home first-aid kit (you may in the car, too) a minimal set of the above and use them only for their intended purpose.

Thus, it was possible to point to the value as a means of control and medical first aid of the corresponding biostructures, but this was beyond just opinion and required instrument provision for fixing resonance frequencies of each of the biological structures.

3.5. The concept of unscientific perception and Reincarnation

Everything that is associated with the "scientific" understanding of "travelling souls" (Entities) and reincarnation has always evoked great interest. I just specify, that reincarnation that existed under the interventional Control System, is no more some sort of violent imposing in the World of the guiding character (from the System). In **2017.01.07** there was exactly four administrative years since one of the Programmed processes of the recreated Control of the people's being on the Earth associated with true state of any subsequent incarnation of the "Spiritual Entity" through the Phenomenon of The Investment that was Shown, but not through reincarnation.

Phantoms and doubles, complete loss of memory, **SUDDENLY OPENED** new knowledge about the events, in which one had not

participated before, the recollections of the past life and knowledge of foreign languages since the cradle – all this is only a minor part that has been drawing the attention of all kinds of scams, especially from the so-called "science". These and similar cases recorded by witnesses, captured on photos and videos, including legally proved, are ***a means of existence for all those who "has been feathering their nest" on ignorance.***

The Academy of Sciences **HAS NOT INTERVENED** in "miraculous" transformations, and it was only on hand to all healers, witches, black magic and white magic and other crooks. ***But today, the frequencies at which they removed the information are disbanded. And it no longer works.***

No	Name	Foundation – Horse knowledge	Non-scientific point of view
1	Atmosphere	The mixture of gases formed by chance	Strictly organized structure of gratings series
2	The Earth	Formed from dust	Exists thanks to the Control System (CS), located at a certain depth
3	Fields	The number of names is unlimited – from the farm to the astral	There are 3 Fields as physical structures, conditionally can be called as electric, magnetic, gravitational; different in frequencies and properties of the charge (octave of the charge 4-512 in Di-structures and 16-128 k-structures)
4	Matter	The whole world, both on the Earth and in Space, is composed of Bohr's atoms	If octave of the charge is less than 66, a rigid structure of the proton atom is formed (matter).
5	Spirit	The spirit, usually the Holy one, exists separately from the matter	If octave of the charge is more than 64 (up to 512), non-inertial mass, quantized on the purpose and properties is formed.
6	The Moon	A piece of the meteorite, captured by the Earth	The external Life Support System of the Earth, the programs generator for the biosphere.
7	Man	Descended from apes	Change of the sperm octave in an appropriate environment forms a human (APE – humanoid of a man).
8	The Brain	Everything that is under the skull	Man is provided with a part of operative brain and a minor part of the long-term memory

Here are some A.Khatybov's terms and explanations who always proceeded from the fact that the "basic constant in modern science is the

horsepower, so all that are known today to modern science is horse knowledge.

Terms and explanations

Insignificant differences between the two points view

	Official science	Non-scientific point of view
1	The solar System was formed after the explosion, there is Hubble sphere	The solar System is artificial, the Space has never exploded, there is no Hubble sphere.
2	A living cell turned out randomly from dust unsuitable for the formation of the Earth's surface	The living cell is the highest achievement of the Cosmic mind, combines the interaction of the octaves from 12 to 4096
3	The remained gas is randomly formed the atmosphere	The atmosphere is layered structures of gratings (*)
4	There is no difference between a mouse brain (which is used for testing medical drugs consumed by man) and a human brain	The human brain is incompatible with the brain of any humanoid.
5	UFO – random appearance of aliens, everyone interested is engaged in their study. Soon their secret will be revealed, and their weapons will become property of the Earth	All the UFOs on the Earth are of terrestrial origin, they are the equipment to monitor the state of the environment (type of zonde); the moon has its own UFOs.
6	The evolution of matter - solid→liquid→gas→plasma (unorganized)	Non-inertial mass (highly organized plasma, arranged in octaves) →inertial mass (gas, liquid, solid)

On July 6, 2003, the formation of the general memory grating was completed. The grating structure are the united dodecahedrons, each of the dodecahedron is a refinement of the icosahedron (the edges of figures and connecting pyramids are the same). If you want to get at the meaning of all this, the sizes and methods of connection are given in the works by A. Khatybov.

Nowadays the processes are under way about which **N. Levashov, and A. Khatybov** wrote in their time – the systems of "horse knowledge" are being removed together with their bearers. The General memory grating will contain only the information **THAT** is **NECESSARY** for the life support of biostructures. Moreover, a powerful grating of control structures has been created. Not stipulated actions of biostructures (read -people) will be destroyed together with their bearers (e.g., turns of rivers, the creation of atomic weapons without knowledge of the physics of the process).

Nowadays there still prevails the "scientific viewpoint", but more and more the concept of non-scientific perception is breaking through the reality which bears the following:

- The Earth is controlled by the Control System, located under the Earth's surface;
- the Control System is a complex hierarchical system;
- on the Earth there are more than 2000 control systems;
- the basic Brain of each individual is stored in the archives of the Control System;
- at each beat period the Brain control of the individual is made with the information recording;
- the Control system uses 7 types of time, one of which (60*60*24) is the beat of the lower grating;
- to transfer the information the Control System uses the music order and the **RESONANCE CONTOURS** of the **SPINE** are the receivers of information;
- to control the Brain the Control System uses a different musical order;
- the order to control the Brain: **DO RE MI FA SOL LA SI NA, LALALA** code – call letters, still existing for a particular genotype of the Brain;
- the appearance – is the shirt, and the Brain transfer is made to the shirt that in the frequency balance is compatible with a portable Brain;
- when transferring the Brain the information in the archive can be fully or partially saved, that is why the individual is able to do things that previously were impossible;
- the substituted Brain can be saved, but typically it is scattered, for all that the ion structure (and DNA, too) are remained the old ones (the sedimentary structures of the old Brain). The new Brain does not form DNA.

When replacing the Brain the Control System assumes that the **NEW BRAIN** in the archive is better than the substituted, but this is not always the case – lately the reverse process is observed. The old Brain cannot be substituted, if some control points are missing, or cannot be replaced (incompatibility of genotype, diseases such as AIDS or tuberculosis, a narrow range of lungs memory, the level exceeding the radioactive frequencies potentials etc.).

The primary task that I hope to realize in the near future, is everything that has to do with the "**PRESERVATION**" of "**INFORMATION**" (almost

a full copy of the Brain or Entity) of the Person who had used **the Programs "SvetL"** and died. Of course, the Generator with all the programs and information – might be just "scattered", but I consider it **UNREASONABLE**. How to change (replace or "remove") the Generator from the bearer (the complex) has been decided and tested. Under consideration is the question of **"SAVING"** the Generator with all that is **"STORED"** in it for the future use by the Brain (Entity) under repeated embodiment (if, of course, it happens). This will significantly reduce the time of "achieving" the lost potential. I **CANNOT** tell you everything now for reasons known to you and associated with the ongoing transformations. But I hope that soon that will be possible. And while I "close" it with points, as N. Levashov used to do.



An important aspect is the method for converting and resizing the structure. Again I refer to the example with an erythrocyte. It is known that the erythrocyte has a diameter of **7-9 microns**, but more than 90% of blood vessels in humans have a diameter of **about 1 micron**. The question that makes many come to a dead end, – In what way does the erythrocyte find room there? The answer: There is no erythrocyte in the blood, it is formed **OUTSIDE** the Control **SYSTEM** (or the Brain) as a sedimentary structure with the loss of the octave of its condition (decreasing the octave 2 times the total size increases 1,284 times).

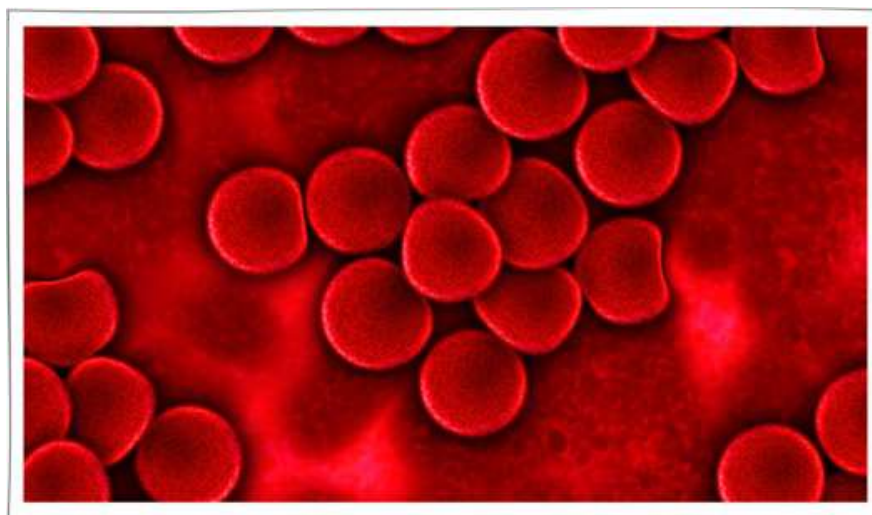

Similarly is the birth of a child. The spermatozoid has an ionic structure and the Brain **in octave 96** (smaller than the atom size). Once in

the "sandbox", that is, in the structure with **MAXIMUM** dispersion, spermatozoid grows rapidly (losing octaves of the Brain). When reaching the equilibrium (octave 71,225625) the signal is developed and the **DELIVERY COMES**. This implies an important conclusion – **the NEW BRAIN** is in a higher octave, and the functions of the old Brain might be **AFFECTED** only **PARTIALLY**.

Earlier I mentioned that the existence of **non-inertial mass** modern science does not even has doubts about. In octaves **over 64 there are 8 different atomic structures** (they are given conventional names – neutron and antineutron, neutrino and antineutrino, etc.). Each of these structures has a range of existence (charge). The loss of charge increases the potential of the lower octave.

An example: when transferring power octave of 65.5 in 32,125225 we get a powerful discharge of lightning (comparable with the power generated by a hydroelectric station for hundreds of years), although the initial state is impossible to see.

Taking into account (excluding the official science) the presence of various "divine" phenomena, as well as advertised astral, mental and other fields (recently a fashionable field is torsion), I want to draw your attention to the growing number of perpetual motion engines, or, at least, the desire to create them. More than 99% of such works are obvious nonsense, even from the official science point of view; but, if in some cases in technical solution the **NON-INERTIAL MASS IS PRESENT** the problem cannot be solved with conventional means and devices, the more so, that the Bohr atom does not change the size and Mendeleev periodic table does not contain non-inertial mass.

Is the existence of perpetual motion possible? If you take the period of time of 100 years, it is possible, by dissipating the high octaves the ion mass can obtain "recharge from nowhere", but only in case of the presence or merging inertial and non-inertial mass. **An example of such a perpetual motion engine is a Man, whose Brain is in the non-inertial structure.**

What will happen if someone takes into his head to visit Pluto in a modern spacecraft? While moving there will be **DISPERSION** of the **HIGHER OCTAVES** (and that is the Brain), so when passing Mars we will have the Brain of Pithecanthropus, and **AT THE DESTINATION** – a **PILE** of **SAND**. All the objects that move in Space, have **gravito-magneto-**

electric Generator that supports the existence of migrating matrices at all frequencies. **Such Generators were, as N. Levashov described, at Vaitmars and Vaitmans** (some for interplanetary flights, others for use in the planetary conditions). This allowed the Human to **MOVE** in **SPACE**.

So, where do crooks and interpreters from science come from and what do they use? Firstly, – out of the walls of science itself; secondly, – because of misunderstanding and inability to perceive the information that **N. Levashov, A. Khatybov** and others left for us. The use of "Horse knowledge" **MAKES IT IMPOSSIBLE** to get to know the meaning of physical phenomena. All existing instrumentation is founded on the properties of Human eyes (phase, angle of the charge sliding, the top octave and the like can not be higher). The lack of instrument base **DOES NOT ALLOW** the official science to accept or reject the new physical properties of the material world (we will not touch on the "Divine world" because it's a different hisTory).

Lack of knowledge about the world around and the ways of its existence leads to a closing around that pyramid of knowledge, that had been built for more than 500 years. In fact, the presence of such science nowadays has led to the existence in Russia of more than 180 Academies, each of which uses the same level of knowledge that has nothing to do with science. Is the situation going to be changed? Yes, it is. Upon completion the Main Program the Control System **WILL** just **ERASE ALL the JUNK** and provide the information that will Make it impossible for the King of nature **to interfere** with the Control System, including the formation of the new atmosphere gratings.

But let us go back to the problem of reincarnation to finally put the full stop on it. There is such a notion as "karma" in shamanic circles. It is supposed to be recording all the deeds and promising "creative" success. There is a lot written about karma, but we have something to add. **Karma** is the feature of the neutrino coat of the Bran to preserve all the properties when changing octaves from **73,450450 to 61,375375** at a carrier octave **of 49,5** (bone structure). It takes approximately **1200-2400 years**, therefore, when replacing the Brain neutrino structure of the Brain is controlled **FIRST OF ALL**. If this period is divided by the average lifespan, you will get a number (amount) of incarnations (reincarnations), which would have to be implemented to achieve these octaves of the Brain. **Before the attack, the seizure of the Eath and annihilation of people this had not been required considering that the length of biological**

life exceeded the given values. In case of disappearance of the carrier frequency within a fraction of a second karma disappears as well, and there remains a small pile of wet sand of a man. At present it has been applied for the publicity and understanding that the similar things are possible as "Technology" with those who were planning to shoot down Boeing over Sinai.

Currently, whether we **LIKE** it or **NOT**, the world is divided into **2 camps – the yogi and the goyi** (the yogi are the control, or those individuals, whose karma was supported by the old Control System of the Earth, **they make 12%**; GOYI are the working material for the experiments). The correctness of the reincarnation experiments was checked on goyi, on yogi the experiments were made.

However, there are exceptions. These exceptions are fairly well documented in history. This applies to the Jews. There is no such a nation. **N. Morozov** described it in the monograph "**Christ**". There were tribes of Jews. The history is founded on fairy tales, and all "the antiques" were



written in the Middle ages, with the beginning of the 500-year program. According to **N. Morozov**, the word "Jew" means **EBR (a migrant)**. That is, the one whose **BRAIN WAS REPLACED**. It was assumed and was presented as if they "were moved", or "expelled from Egypt". The first experiments on changing the structures of the Brain were made exactly in Asia Minor. When transferring a new Brain the old one is eliminated, but the new one **CAN NOT** pass the test and cannot be put in. In this case, the control over the actions of the Brain is disturbed, and such a Brain

HAS TO BE DESTROYED. This extends to the current processes. What is typical that such a phenomenon is being widely spread. In the old Control System the name "Jyd" – Jew (or yog) was **introduced** for them. **Jew (or yog) without a Brain**. It has already nothing to do with the Jews. The slogan "beat the Jews and save Russia" refers specifically to this phenomenon. To create a public attitude there were organized "black hundreds" of the ground – attackers, the "Memory" society, and so on.

For "Jews" the old System established a temporary support (the total lifespan of 54 years) and made of them regular biorobots with the specified functions. If within the period of 1933-1945. the total number of biorobots

was **6600000** (almost all were annihilated), at the present time they make more than **33% of the population**, and therefore there was a danger of a new (nuclear) war. At the end of karma robots jump out of the windows, perpetrate accidents, take up arms, etc. Such individuals are **ESPECIALLY DANGEROUS** in the army. Modern science does not have ways and means of detecting and neutralizing robots. The first report of the emergence of robots in Russia was **in 1472 ("The arrival of the first Judaizers in Russia")**, that is, at the beginning of introduction of new Brain, and it did not suit everyone. If karma was normal, the control system at **100% supported the possibility of reincarnation**, and it was performed once in 12 years for all yogi (or, in exceptional cases, on merging of a few beat periods and availability of replacement, an example is Anastasia). I am sure that the new Control System will "find" another (except the war) way to remove robots and the reasons for their formation.

3.6. Sleep as karma control

Sleep and dreams, interpretations, and dream guiding books are the basis of almost all of the practitioners of shamanism. It is known that there are lots of types of dreams: they are color dreams, sleep with no dreams and instant dreams (you sleep a few minutes, sleep well and had a dream that lasted a few hours). While sleeping a man can travel, do very specific things, be in places that are inaccessible, etc. First the idea of sleep as a means of control **was expressed by Freud**.

On the Earth there is nothing accidental. As I have mentioned all living beings are biosensors, and if the frequency balance is changed (in line with the Program) then unnecessary biosensors disappear and new ones come out. For all that, you should keep it in mind that according to the Program the frequency balance **IS ONLY GROWING** (the octave is getting higher), so gradually biosensors of a large size disappear and smaller ones appear. ***Especially carefully the Control System monitors the Man.*** **MUTATIONS ARE NOT PERMISSIBLE**, and once in the beat period a short-term withdrawal of the part of the Brain (according to the schedule) is made for control purposes. In this case, the taken part of the Brain is tested, and according to the test results a correction is applied, and then the removed part of the Brain is returned. If the correction is insufficient for the whole of the Brain the carrier frequency is removed or karma is reduced.

On the Earth there are 12 related Control Systems, and 21 Control Systems. For example: the control System for England is located in Greenland. The removal of part of the Brain was carried out according to commands from the Moon.

The drawing symbolically shows the memory library. Testing is performed at high octaves. There is different time over there (144 times reduced), but if that is **NOT ENOUGH** to make the complete test, the test stops suddenly, and the part of the Brain (partial) is taken back. During the next testing this part of the brain is placed a step below. Targeted communication makes it possible to return accurately the Brain back where it was removed from for the testing, but if by this time there had been some changes in the atmosphere, the address might have been changed, for example, a woman's Brain is returned to the man and vice versa. Hence, the growth in the number of gays and lesbians. Nowadays this happens very often. **THE TEST** is a kind of **FILM**, every sequence of which checks each cell of the Brain matrix. The signs of checking are partially preserved.

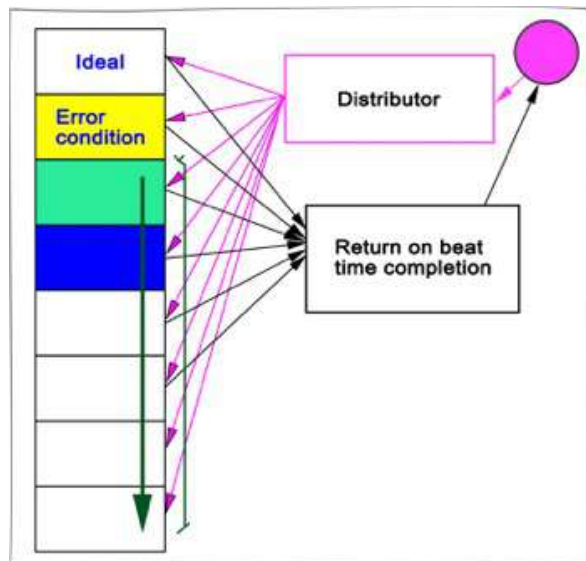

Yes, the sleep can prompt a disease or general condition of a Man. The interpretation of dreams has nothing to do with this process. Sleep is necessary, indeed, but not as a story fragment, but as a state, because exactly at this moment there takes place correction in many, and sometimes in all the processes of the guiding, control and overall condition of the energy-informational state of the Brain and the flesh cells.

The address loss is a tragedy for the Control System since not only the control system is disturbed, but the point, as well. Upon detection of the

address loss, the Control System eliminates the gene pool at the new address, and that Man becomes a ballast for the society. **All the so-called "minorities are the defect in the work" of the Control System under ideal conditions. And the System GRADUALLY DESTROYS their Brain.** The control points of the Brain matrix in all octaves are given in a separate work by A. Khatybov. Here we note that only to control the pancreas functioning there are **8192 points** in the matrix of the Brain. All the drugs used by Man, either **DISCONNECT** the **BRAIN** from the ionic structures (shirt) or **ADJUST** the **SHIRT** according to the instructions of the returned part of the Brain. **There are no and cannot be medicines that affect the Human Brain.**

3.7. Language as means of communication.

Once I asked Boris Makov: "how many languages are there in the world?" "Two, – he answered, – **one pink, the other with some fur** (when there is a disease)".

Unlike humanoids, a Man is able to speak. Detailed analysis of sound forms is given in the monograph "**Christ**", **volume 3** by N. Morozov. However, the reason of formation of coherent speech **IS UNCLEAR** to modern science.

If you approach this problem from a non-scientific point of view, then the Human Brain contains a "Translator", i.e. a way of transferring **MUSIC ORDERS** received by the spine octaves or stored in the operational or long-term memory. There might be several such translators. Without such a translator you can **LEARN** a foreign language for hundreds of years with **NO USE**. If there is no translator, the Brain **CANNOT BE FORCED** to learn an unfamiliar language. **Under reincarnation it was possible not only to transfer the portable Brain's events records, but also the translator transfer that** allowed to easily and quickly update their knowledge of the language.

The Control System while checking the Brain validates the work of the translator and, if necessary, complements (making higher the frequencies potentials) the Brain with "instructions" for changing the ionic part (the shirt). When reducing the frequencies potentials you can forget everything, lose your memory. And nowadays this happens rather often.

It is well known the technique of learning a foreign language while sleeping. In fact, there should be **used 8-digit music**, and not 7 (12), as it is customary now. In addition, the record must be made in the appropriate octave (the maximum frequency of the radio-set is octave 16, which is insufficient for the instruction the magnetic pulse potential). Instead of the accurate "requests" to set up a translator from the language nowadays there are sound effects like a talk of the crowd, and the Control System can only either increase the potentials density of the earlier input possibilities or remove them at all (you wake up and discover that you have forgotten the native language, and there is no other one). By increasing the potentials density there can be effects (not immediately) of the language knowledge.

The Russian language **WAS DEVELOPED 257 years before the birth of A.S. Pushkin** (the English language, as well), and since that time the frequency balance of a living Cell and bone resonators have been modified for the new structure. These changes have been made throughout the Earth, but considering the "local control structures", for example, in China, Japan, and Korea. I want to draw your attention to the fact that the cogitative process in the countries using hieroglyphs differs from the usual. It is **a PATTERN of IMAGES** and changes in this structure, which are uncharacteristic of the stereotype would lead to the destruction of a large part of the Brain matrix. Now this process is just starting to "unfold" exactly with respect to the Russian language. ***The words accompanied by images, and visualgraphy, or images passing into words are the basis of the future mutual understanding among people.*** Exactly in the **Generator "SvetL"** and its **Programs** it is provided the "interaction" with the Generator in this way. This makes it possible to adjust it and "operate" it in accordance with the necessity. And the first experiments that are performed by the Users themselves are very encouraging.

3.8. Blood, DNA and the lungs memory

When replacing part of the Brain usually there takes place the change of the blood group. Why? – Medicine is not able not explain it. Along with it there changes the **SEDIMENTARY STRUCTURE**. Previously unknown connections and particles (and their sizes) might appear. If there is a change in blood groups, there **HAVE TO BE CHANGES** in the structure of certain organs. As a rule, it concerns outer exchange structures, i.e. the lungs. If the

Program provides for changing the potentials ratio in the atmosphere gratings and (or) the introduction of a new grating, then in the first place, the lungs have to be ready for such changes. Breathing exercises are subordinated to the Brain, and the breathing capacity limit cannot be more than the capabilities provided by the Brain (the lungs memory). With the reduction of the "passage" a Man gasps. As a rule, the reduction of the passage (and sometimes just elimination) occurs in a sleep, when part of the Brain is missing. In case of discrepancy between the "gas" environment and the lungs memory within 4 hours a signal is carried to the Brain, and if there is **NO CHANGE** to rectify the situation, the Brain is **REMOVED**.

The very name of the **DNA** (acid) suggests that it is just the medium for the change of the high octave (the spermatozoid also grows with the loss of octaves in an acidic medium). But this medium is highly organized, and using modern instruments it got possible to detect some of its features. There have been collected 64 combinations of adenine, cytosine, guanine and thymine. However, **DNA is a "conveyor"** used by the Brain for the formation of ionic structures and metabolic processes. **DNA is a sedimentary structure**, and in replacing the Brain it remains **UNCHANGED**. Just on this "conveyor" other details are to be assembled. Science has determined that out of the 64 codons 20 (known) amino acids are formed. The remaining **44 are unknown**. Note that these 20 amino acids are the analogues of the unit distributions on the "conveyor." If the "conveyor" is an "assembly unit" then there should be a "forging shop", "paint shop", and so on. We have to assume that the unknown 44 amino acids are strange "mafia" structures. Any organized "production" becomes surrounded with them.

So, what was **CHANGED** during **REINCARNATION**:

- blood group;
- memory of the lungs;
- metabolic processes, including motor coordination (could change the gait);
- the memory structure, for example, knowledge of languages, skills in singing, etc.;
- new information records previously uninherent to the individual;

I would add that after reincarnation, **the NEW BRAIN** changed the "shirt", i.e. a man could be much younger or the opposite – a 3-year-old child could turn into an old man.

Thus, reincarnation had a feature of the Brain return when giving birth to a new life, or the **CURRENT** Programmed Brain **REPLACING**. Basically, the latter was used in the great amount, with all the consequences. Reincarnation was made only by the **Kailas Complex**. Only the representatives of the "Golden billion" were subject to reincarnation, and mainly the second part (the Brain replacement). If during the life time of the representatives of the "Golden billion" the Brain discrepancy to the Programmed requirements was detected, the **BRAIN** was **ELIMINATED**. **In 2000** there was completed **the 500-year** Program for the formation of the "Golden billion". The Control, "made" before the Easter, revealed significant differences in the Brain functions, and the Programmed requirements. **N. Levashov had "had a hand" in it**. In this regard all of reincarnation functions were removed up to the normal restoration of the Programmed requirements. All the representatives of the "Golden billion" since that time have been on **GENERAL GROUNDS**, without reincarnation. However, the System makes a selective individual Brain replacement, both in terms of exemptions and in terms of a complete replacement with the imposing of certain executive functions both for the present and the future. In this process the **Programs "SvetL"** have become an invaluable tool, with the possibility arising, to make a new record of information which was not earlier inherent to the owners with the subsequent Brain "transformation". But the Programs are **ONLY** a **POSSIBILITY** and the Owner's perspective to whom close attention will be paid. All the rest depends on the man. There could not be another way. Connections, bribery and the back door are **NOT ACCEPTED**.

The Church, which was established on the information about reincarnation, nowadays **IS** a **PARASITIC** element. In no way I want to offend the feelings of believers. **It's their choice and right**. And all the tales about a "future life" are designed only for their happy existence. And as much as I tried (using N. Levashov and A. Khatybov's works) to present my knowledge in an accessible and easy way, I do realize **that people are not able to suddenly part with the familiar clichés**. Especially if the mind has lost its elasticity and got rigid, which is characteristic of the old age – to part with the myths, **THOROUGHLY INGRAINED** in their heads, is not that easy. **But if people would like to recover Human properties to their distorted consciousness – that is quite possible, and my book is a step in solving this problem.**

Chapter 4. The basic functions of the atmosphere layers and the formation of people's consciousness

The change of the laws of nature is impossible. Ignoring the law does not lead to its disappearance, but to the disappearance of the one ignoring the law.

We conceive the truth when we see it. And let skeptics and mockers say whatever they like. Ganders will ask if you say something they do not want to hear: "Why do you know that this is the truth, and not your delusion?" The truth is often so simple that one does not believe in it. We conceive the truth when we see it, just as we know that we are awake when we are no longer asleep... The truth is the best weapon. ***Every truth is a system of knowledge, but not every system of knowledge is the truth.***

Today one can turn a blind eye to what is happening, to a sudden and rapid disintegration of the life habitual for us only **UNTIL** one day when the horrifying fact that we are really in great trouble **REMINDE** us in such a way that we will not be able to ignore it. Exactly this kind of reminding we are beginning to observe now. We are faced with events and conditions that are impossible to ignore. This is not a reason for despair. In fact, we do **NOT** really **NEED** any despair now. It was exactly the despair that created the problem and, of course, would not solve it. Time has come not to get despaired, but to correct what has been done. But you need to understand that the **DESTRUCTION of THE OLD** makes sense only when you **COMPREHEND THE NEW**. It is pointless to change the current understanding of what is happening for any other understanding that is not "supported" with **NEW KNOWLEDGE** and the experience of having been use them, because there will pass time – maximum of one or two generations, and maybe less, and the imperfect new one will get worse than the old one.

The solution of any problem has its own sequence. Without solving the previous one, one can not undertake the following. **WITHOUT BUILDING** the ground floor, it is impossible to proceed with the

construction of the following floor. If to act out of place and not in due time, violating consistency, □ this will, at best, be a waste of time, at worst □ it will do harm.

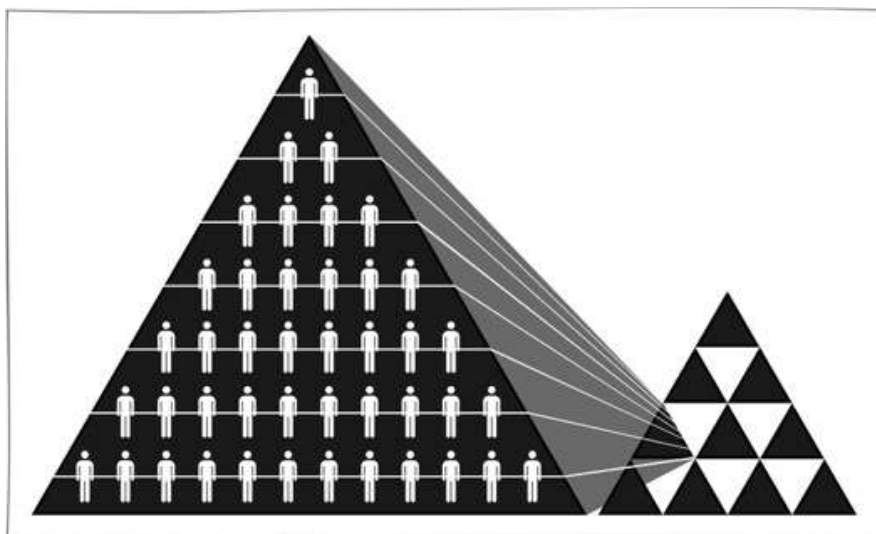

At present the whole world is seething, and this is happening before our eyes. Globalization, about which the majority knows little, has opened the borders of all states for the free movement of information, money, goods, and human streams. But inside these streams there moves **SACRED KNOWLEDGE**, which is **BEYOND** the **TIME**, space and power. And the "winners of election campaigns" or "military coups" are not able to modernize it under their intentions. The ruling "elites" still regarding themselves as the rulers of human destinies are *now experiencing the strongest intellectual and philosophical crises* that are already **NOT ALLOWING** them to influence (even if they shed sea of blood for the sake of it) the events in the world, and especially the people who are "waking up" from the age-old dream of ignorance just before their eyes.

Earlier I mentioned the words "sacred meaning" (sacral knowledge), which, perhaps, are taken for a literary ornament of my thought. This is not true. The fact is that any text or material monument is presented with facts, names, dates that are known and understandable to all from **the media, TV, Internet messages**. **But this is the most superficial level of comprehending reality**. Understanding the reality begins with immersion into the context, deciphering the values that the author defends. **N. Levashov** used to say exactly about this, and he wrote his works using this method □ the method of layering for a certain level of readers'

understanding. Look at his paintings, which he made in computer graphics and just try to explain (to yourself) the meaning of the image. These pictures carry very serious information. In the same way, all the writings of the **SRI (Scientific Research Institute) of the CPS (The Centre of Preventive Strategies)**, the writings of **Khatybov** and your "**humble servant**", as well as those who writes with prospects of developing people's understanding.

Immersion in a layer of the text – in the subtext, – deciphers the purposes for which it has been created. And only immersion in the following, deep and sacred levels of the text, brings to the **UNDERSTANDING** of the **MEANING**, for which facts, figures, dates, names are mentioned. Such a difficult immersion in the text can be compared with a record dive underwater, which requires special training, equipment and, most importantly, knowledge. There is a fourth and fifth levels of understanding the sacral meaning of the text, which I mastered, or rather, N. Levashov taught me. He did it unobtrusively, but persistently, perfectly realizing why I would need it. That's the Man he was.



My first experience in this was the "writing" of the **User Instructions for "SvetL" Complex**, which, as you have already got to know, carries **A LOT MORE INFORMATION** in it than a set of letters in certain words. At that time, it was impossible to "open" the operation of this technology, because almost **NO ONE HAD UNDERSTOOD** this, and those who had had it wanted and offered to use these technologies, to put it mildly, **NOT** for their **PURPOSE**. Today, the information laid down in the Instruction became open for many Users (though not completely). This is evident from the questions that they began to ask, advancing along their **WAY OF KNOWLEDGE**. But there are two more levels in the "dive." Unfortunately, I **HAVE NOT REACHED** those depths yet but I hope to. N. Levashov mastered all these levels, and in such a way "put in" the relevant information

with its sacred value both in his works and in the pictures that he "painted." But this is another story, which I am going to tell later.

To sum up, there are known well-known. These are things about which we know that we know them. There are known unknowns. These are things about which we know that we do not know them. There are also unknown unknowns. These are things that we **DO NOT KNOW**, that we **DO NOT KNOW** them. But there is also informational masturbation, when the application of knowledge is replaced with getting more and more new information, and today this is the sin of many. As a result, development is replaced with the process of obtaining information for development. You become **MORE** informed, but **LESS** intellectual. When this goes on a year after a year, it encourages self-esteem. You are becoming more and more **INFORMED** and ever more **EMPTY**. Information without **TRANSFORMATION** of **KNOWLEDGE INTO SKILL** *is a poison that destroys the ENTITY (the Brain).*

4.1. Consciousness as a factor

Up to this day, many world scientists have been in a position of searching for the answers to a very significant question in people's being: how is **CONSCIOUSNESS**, both of an individual, and public consciousness of a specific community of them **FORMED**? What is Consciousness in general, as it is? Is the process of its formation natural, as it was considered earlier, or was it controlled from outside (but not in the sense of the active administrative and technical influential participation of certain political propaganda in any form of its manifestation). The generally accepted qualificational hierarchy of types and kinds of Consciousness, saturated with "professional" definitions from representatives of social and medical sciences, psychologists and other specialists, ultimately did **NOT ALLOW** people to fully clear up the **MEANING** of **CONSCIOUSNESS**. Moreover, until now, the question itself has been very problematic: In what way do mental and cogitative processes work out?

What is the Brain, and how is it really structurally made and versatile dynamic? If the Brain of people is practically alike in all of them (from the medical point of view), then why are they **ALL SO DIFFERENT** in their judgments and actions?

Many advanced scientists, thanks to the modern technical means of observation and registration of various induced reactions and changes occurring with the Brain of people under the influence of affecting factors of various character were convinced that certain regularities from the number of reactions recorded by them according to its factorial physical state are indeed being manifested, and this is **NOT DISPUTABLE**. But the obtained experimental material has not made it possible so far to come to the unity of opinions and, first of all, among various scientific directions. Closer to the truth about the essence of the consciousness itself were, oddly enough, the theologians and founders of judgments about it, supported with the basis of religious dogmas. They, though, with a certain uncertainty, but **WITHOUT** any **SLYNESS DECLARE** that *consciousness is given by the ALL MIGHTY*, and people are "only his mouth and everything that they create is the creation of God." In this there is a much closer approach to the truth than any other proposition, erroneous not because of the people's fault. Many modern scientists more and more often express the modest idea that the "Creator of the World Created" himself is far from being indifferent to people's reaching their intelligent state. The consistency and irreproachable timeliness of the **LEVEL** of **KNOWLEDGE** concerning people's deeds and events in separate directions of their controlled existence throughout the entire previous history is simply amazing with its anticipatory event accuracy in time. It is not the consciousness of people that determines their being, but, on the contrary, their social being determines their consciousness.

The closed research conducted by specialists of some scientific fields practiced in many countries of the world with the aim of acquiring different variants of active influence on people with the intention of imposing upon them forms of control over them through the concealed violence over their Consciousness would partially represent some interest. But the general true picture of the state of people's Brain such experiments have not given so far. Such experiments convinced the initiators only in one thing – to **FORCE** someone to be **CLEVER** has **NOT** been **POSSIBLE** so far, but to produce the executors of some unreasonable forceful character for the subsequent limited utilization of the experimental ones proved to be easier and more profitable with the use of other, simpler methods of influence, exploiting mainly human vices and interest of a personal nature. Reasoning and research in this way can bring closer to revealing some systemic deep secrets of the real design of the Brain, including the realization of the very fact of the functional purpose of the Man of the Future within the ongoing changes on the Earth, **NOT LIMITING** the depth of judgments with the previous

frames of the "philosopher's stone". First and foremost, it is for this reason that it is expedient to understand in what way, earlier, on the side of the old Interventionist System, **EXTERNAL CONTROL** of all the people's being and of the level of their Knowledge through their Brain was carried out. With what forms of influence was it possible to activate the various functions of the Brain? How was it being perfected on the stages of development of general and event chronicle processes? This will make it possible to perceive ***what Consciousness is, the way it had been formed, and changed over the stages of historical development, and so on.*** Serious help will be given to us on the issue related to the true Structure of the Atmosphere and the Control functions imposed upon it, which were put in its gratings by the old Control System, including the processes of formation of Consciousness and the public Consciousness. ***Consciousness creates reality, and you create your consciousness.***

4.2. Functions of the Interventionist System Atmosphere layers

In the scientific community there remains less and less former self-assured confidence in the unshakable firmness of the supposedly "natural basis" of Nature's self-development and similar natural development of the Civilization harmonious improvement, including people, and much more.

Finally, science has pondered the problematic questions – who or what, over whom or over what carries out a kind of mysterious governance unattainable by our Consciousness. And is there a fact in itself of its presence? Is there any control over them in people's consciousness, and if there is, then, how does this happen in the physical plan of the process itself, as it is? In what systemic way is the **HARMONICITY OF DEVELOPMENT** of all the variety around us in the material and non-material states of energies achieved? Probably, instead of stating foolishness of the necessity of the existence of naturally natural "food chains" in the whole biological environment, there are some more serious reasons for the existence of such a vast diversity of substances of biological species. Is any correction of this state of the **COMPREHENSIVE CONTROL** possible? If it is, what place is assigned in this current correction of conditions to people in the future, what is going to happen to them and what steps are acceptable

or necessary to take now to preserve their lives and be called for on this Planet, and not at the level of the current consumer prolific "animal husbandry for their own good? This is one of the key questions that is asked by those who has embarked on the path of **KNOWLEDGE** and who at least has begun to "understand" something, having awakened from a dream of ignorance, into which we had been sunk.

How did it happen that for the **LONG PERIOD** of the existence of life on the Earth with the participation of people, the comprehension of the essence of the occurring physical processes of supposedly some "self-development" is shielded with a dense curtain from the people's deep knowledge? Why did the "surrounding nature" turned out to be so apophatik¹⁹ for "thinking people"; they have already conquered everything in "the Nature" to an unrecoverable state? Who isolates them from such knowledge and why?

N. Levashov wrote about it very clearly. He deeply investigated this process, and it looks something like this: the deeper the world is "cognized", the more questions arise about the physical essence of the process of its existence. Most of the former basic constants and dogmas of both scientific and religious positioning fall apart in ashes, and the "new" ones are not always presented intelligibly and sensibly. Inquisitive minds are often carried away by the esoteric world outlook, demonism, cosmopolitanism and so on, thus making the way to the **TRUTH** even more **UNATTAINABLE**, leading such an unstable knowledge to a state of complete misunderstanding of the truth itself.

There is only one path for us – to find the truth about the "World Created ", which will **MAKE it POSSIBLE** to **CLEAR UP** the hardened Knowledge at least about people as some kind of intelligent beings (the only one of the whole variety of biological world substances), pave the way to the development of the general level of the *former stagnant state of Cognition of the surrounding World*. Is it possible within the current level of the Brain octave, the state of its functions and the corresponding mechanism of people's awareness? And if it is possible, – what **CAN** people **DO** for this? Here comes the question in relation to "**SvetL**" **Programs**,

¹⁹ from Greek apophatikos – negative) is a property of thinking that promotes the self-denial of man as a perfect being, the use of Apophaticity (free will for the fulfillment of Divine commandments and the constant abiding in the state of confession of his sins and repentance.

their application, the expansion of knowledge and personal understanding – what they are for today.

Within the framework of the problems of formation of individual and public consciousness of people, the nature of its current state in connection with the ongoing **SYSTEMIC PROCESSES** of cardinal changes, let us consider the construction of the Earth's Atmosphere Gratings. And to be more precise, we deliberately limit ourselves to considering only some of the basic functions of the control so that to ensure the existence of people's lives.

4.3. Formation

All the true Atmosphere layers, as the most complex harmonious Construction of a strictly identified set of its energy gratings, were formed in the model creation of the Earth. Exactly this true layered design of the atmosphere provided, first of all, self-governing by the Programmed "Natural Habitat and the Controlled Environment", which, in turn, fundamentally based the very fact of the "origin" and existence of the true Life itself with its orientation to the "Intelligent basis".

Moreover, only such a specific design of the Atmosphere was to be one of the mandatory conditions and at the same time an important closing link in the formation of mandatory conditions for ensuring step by step development of the Earth Mind and its unconditional very important role, – the Human Mind. **NO** other harmony **COULD HAVE BEEN** in the development of the true Earth Civilization, and all the rest is inappropriate for *the intelligent life*. Such is its true Programmed essence and the embodying civilization Entity.

For the Earth (as a specific model complex □ a Planet), located in its functional endowment in the Common Hierarchy of the Planets, program-oriented to the development of Civilizations of "Intelligent orientation", the following is envisaged (enclosed): The entire incarnation of the most complicated path in the development of its Civilizations **IS TO BE IMPLEMENTED** in *eight consecutive stages of an increasing level of perfection* (in a tact of event-driven time in the course of the gradual Programmed chronicle process), with the achievement at each of them the complete perfection of the harmonious "**energies being**" within the strictly set up limits of the octaves of these energies for each particular stage.

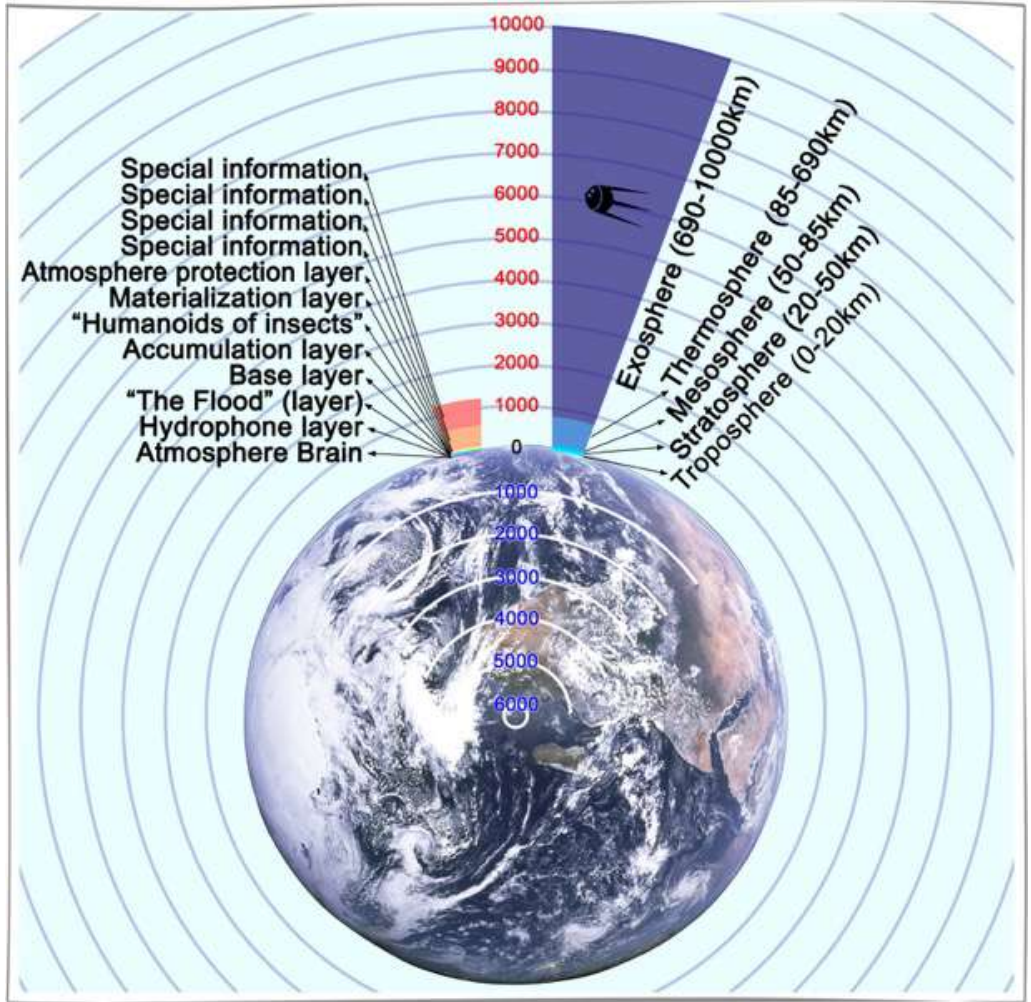

Such a complex process of development in the harmonious being of energies envisages both its own Programmed Control capabilities for all the ongoing chronoprocesses with the help of the Earth Control System and the possibility of "external" assistance and control providing **LIMITED INTERFERENCE** from the outside in the process of governing on the conditions of guardianship. Here it is worthwhile to remind those who are skeptical about **Levashov's** abilities – he was able to interfere and did interfere (even judging by what he wrote in his books) in the processes of the Control.

It looked something like the picture. It shows the work of **Levashov's Generator** (transferred from France to Russia) with the interaction and correction through him of the energy of one of the processes of the Control, a concrete action (process) related to the real events.

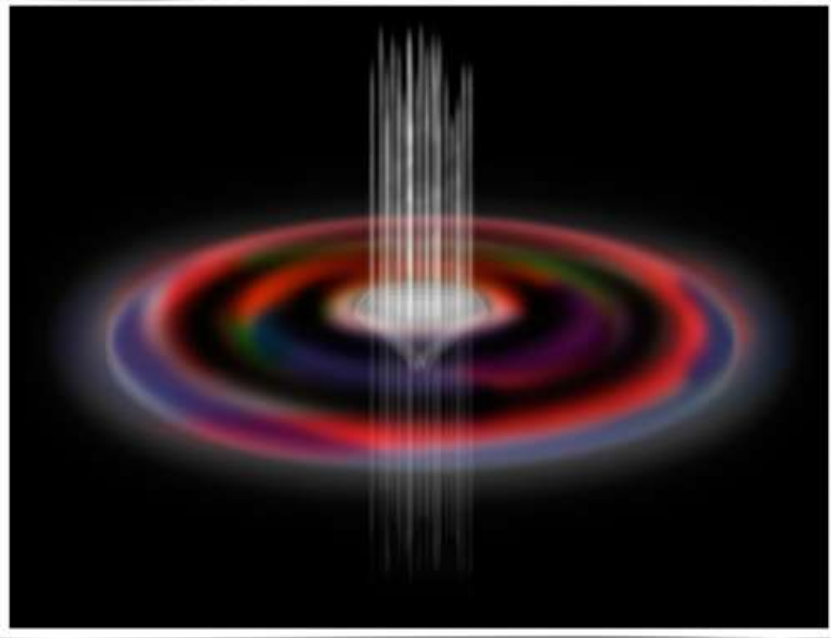

By the moment of the Interventional capture of the Earth²⁰ it had been only at the **FIRST STAGE** of its civilization development, providing an admissible limit of getting its perfection for "the whole spectrum of arrangement of life being" of energy octaves, equal to **12-512**. Our Earth is young by the standards of another kind of time. It was exactly within these limits of the energies octaves that the entire true "**The World Created**" for the Earth Planet was formed, as it began its own far-reaching path of the perfect development, possessing a unique state of life **STEP-BY-STEP GOVERNING** aspiration for the "**Intelligent²¹ Orientation.**" This **NATURAL STATE** of the developing energies matched the construction of its harmonious and rigorously identified Structure of the energy gratings (identified dodecahedral structure, i.e., the **Di structure²²**). The developing process was under a single Control on the side of its own Earth Control System, programmed to achieve the perfect harmony of the "energies being" of the entire Planet in their **material and non-material**

²⁰ Materials in Part 1-4 "Fundamentals of the Formation of the Mankind".

³ "Intelligent" is like thinking. Accordingly, replace everywhere "intelligent with thinking" and then you will see that wisdom is a goal or an already achieved state, and thinking is a process leading to this goal.

⁴ Di-structure – 8 dodecahedral-icosahedral (DI) blocks, each block has nested DI blocks (total in one DI block 44 attachments). The structure is constructed using the properties of the golden section (without the golden section – just nowhere). The state of the structure is **HIGHLY ORGANIZED PLASMA**.

states. I would like to note an important feature. The Civilization developing²³ process for the Planets, having the existence of a concrete life on each of them and being in the Common Hierarchy²⁴ of the planets of the "Intelligent Orientation," is to be some **ENDOWED WITH** mandatory condition. This **MANDATORY** condition, connected, first of all, with the fact of recognition of the achieved level of their perfection in their development and transition from stage to stage, is the obligatory achievement of the necessary level of perfection of the Mind of the Planet. Achieving **ONLY** a harmony of the existence of energies in their material and non-material states is **NOT SUFFICIENT** to be recognized as the appropriate level of development of Civilization on the Planets having life. The same reasoning can also be found in N. Levashov's writings. **Lots of Lives, but few Minds!** The rest of the Planets not having "living conditions" are **PREDETERMINED** by the Program for the **LIMITED** process of their development or the absence of such at all. They are functionally used as "warehouses" **for the accumulation and storage of some forms and types of energies in their various states** as producing generators of something under someone's control (including information of various kinds) or performing various types of protective, recycle-regenerating, experimental functions, etc. And, accordingly, by their constructive form and content they are arranged in a completely different way (in contrast to the Planets possessing living conditions), but harmoniously to their identified function. In each planetary, galactic, intergalactic and other **CLUSTER SYSTEMS**, specific component elements of the Planets are required. Variety and their composition depend on the functional purpose of this cluster level.

For the Earth, in particular, **the development of the Mind of the Planet IS IMPOSSIBLE** without the harmoniously developed Human Mind as the very fact of recognizing the perfection of the Civilization development level. Consequently, the transition to the second stage of development, which provides for raising the upper permissible level of **energies octaves from 512 to 1024**, etc. with the increasing discreteness, **IS also IMPOSSIBLE**, i.e. there is no, and there cannot be any movement in its development.

²³ Proceed as a consequence of the cause. From an insignificant case, important consequences emerge.

²⁴ Hierarchy (from other Greek – ιεραρχία) – the order of subordination of the lower links to the higher.

For this reason, the recreating Man is important precisely by the fact that his associated ***Mind is an integral part of the Mind of the Planet***, without which the latter is improper (incomplete). But the Human Mind is also not independent, since it only is able to develop in the process and through the development of the Mind of the Planet, and necessarily with the accompanying process on the side of the true Earth Control System.

In this connection, all sorts of myths about the development of supposedly some kind of **the fourth Civilization on the Earth** are **NOT TRUE** (just invented) and are an evil intent on the part of the Interventional Ebr system. The true basis for such judgments does **NOT EXIST** at all, since even its first "native" civilization has not been developed and completed to its perfection and harmony, since **18000** years ago such a development was halted by the intervention of the alien system!

This most compound process of the complex development of the Earth Civilization (so far within the limits of 12÷512 energies octaves) has now begun to **RESTORE** in all its **TRUE** states and directions, getting support of the original Earth Control System and external guardian assistance from outside, on the side of more developed Governing States and Civilizations. At the same time, all the consequences of the former Interventional constructive and governing interference have been **ACTIVELY** liquidated.

It was in this "process" that **N. Levashov** took an **ACTIVE PART**. This was the **MAIN REASON** for the assassination of Svetlana (his wife), and then him. Now we already may talk about it. Only a part of what was done by them and realized (here I emphasize – together with Svetlana and without her participation), is described in his works. All the rest was done without publicity (although those who had to know about it they did know).

Very appreciable help was given to Levashov by the so-called "**White Brotherhood**" and especially when the so-called "**The Abode of Gods²⁵**" appeared within the "visibility range".

⁷In parts, Levashov wrote about this in "The Mirror of My Soul".

4.4. The Abode of Gods

In the last century, Russian mathematicians carried out an interesting study. In a powerful (for that time) computer the scientists downloaded data of all the laws of the natural sciences and asked one question: "**How does it work?**" The computer gave the answer: "**To make this work, there must be an external governor.**" **In fact, the existence of God was confirmed.** (We have already understood what God means). But where does he "live"? Where is his "abode"? Perhaps the answer **came in 1994**, when the Hubble Space Telescope took photos of the unique object.

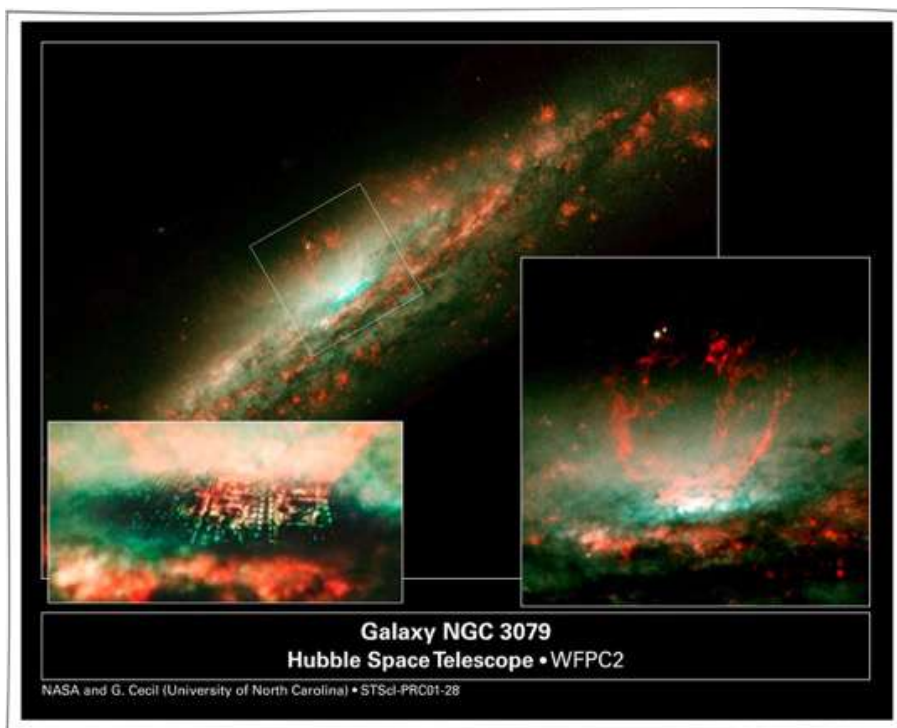

In the photographs, the interest of scientists was caused by a small vague spot that did not explain any interference or optical effects. Additional pictures were taken with the maximum resolution. What the NASA scientists saw, **the government immediately classified as secret.** But this information became available.

What did the specialists see in the picture? Professor of the University of Florida **Ken Wilson** saw a city, a real city. The shining structure, reminiscent of Swift's "flying island," seemed like an unreal city of the future. The object that appeared in the picture was called "**The City of Gods**" or "**The Abode of God**".



This city is stretched in space more than several billion kilometers, and in comparison with it, the Earth is just a speck of dust. What has been found in the universe? There are lots of assumptions on this subject, but they all can be brought to **TWO VERSIONS**.

6. An Unknown super-civilization **HAS CREATED** a **GIANT CITY**²⁶, which is noticeable at such a huge distance, although previously objects of such magnitude had never been found.

7. This is the place where the Creator really dwells.

Scientists continue to study this site of the universe, but all the new information is still classified as secret. It is classified as secret only for one purpose – they (some of the "powerful of this world" – ebers or blacks, or spiders, as you like it) have "**RECOVERED** their **SIGHT**": **Firstly** – "this" has been created beyond their will and understanding. **Secondly** – "this" has destroyed much of what had been created within their Control System and not only. And **thirdly**, the **White Brotherhood** exists, and its "representatives" control the changes that are taking place, and they reinforce their ranks.

After the assassination of N. Levashov, as I wrote in 2012, **8 "people"** involved in his death, **6 in Europe** and **2 in Japan** were annihilated. The slogan of this action was "**For Christ, Alexandra, Nicholas and Sevastopol ...**"²⁷ This is how it was "covered" in the media. "In Osaka, Japan, on August 21, 2012, immediately after lightning strikes and a severe

²⁶ N. V. Levashov – The Mirror of My Soul.

²⁷ Radomir, A. Khatybov, N. Levashov and... Sevastopol (as the planned capital of the Jewish Kaganate).

thunderstorm, some residents were **SHOCKED** by an unusual **PHENOMENON** – the light pillars." (The photos are taken from Twitter).



One of the authors writes that he only *wanted to shoot the lightning, but it turned out to be a photograph of the post that appeared immediately after the lightning strike*. He, for some reason, called this phenomenon "The strike from Laputa" (Laputa – "the Flying City" in the clouds). Further, I hope, everything is clear.

Approximately the same happened to the people who had been preparing to "shoot down" the plane over the Sinai Peninsula. They are going to be mentioned later on – practically **NOTHING REMAINED** of them, as A. Khatybov put it – "crumbled to dust", and after that, many "powerful of this world" got seriously worried.

In the fall of **2014**, I went to Europe, to the foothills of the Alps, where I met Levashov's Friends. N. Levashov mentioned them for the first time when he described everything that was connected with the assassination of Svetlana. Nicolai tried to "revive" it, but he did not succeed. And then he asked his Friends to do it, because, as he said, they had such capabilities and were able to help. But he received a reasoned refusal and justification of the **POINTLESSNESS OF THE SUCHLIKE**. He told me about this before leaving for Svetlana's funeral, when I came to see him just a day after all that had happened. Human emotions are emotions, but even then I knew that emotions are hostile to clear thinking, because they are – to some extent – an indicator of some mental disorder. Nicholas felt Svetlana's death keenly. But, in my opinion, he realized that there was also a real expediency. This expediency was in the actions of his Friends. And if we go back to the beginning of this chapter (to the layering of writing texts), Levashov's words about Svetlana's death bring us to the conclusion: "Apart from Levashov,

there are **Humans** on the Earth who are **MORE CAPABLE** "in comparison" to N. Levashov (although this, in my opinion, is incorrect comparison)." Here I got to know them (or rather they got to know me) just on the second day after **N. Levashov's** funeral in Moscow. I wrote about this in an article on **TRAGIC EVENTS on June 11, 2012.**

At the meeting (or rather, the seminar) in the Alps, much was learned and some practical skill came in many ways. After that, I already reasonably checked the efficiency of "**SvetL**" Programs, having realized their "hidden" capabilities, as well as the possibility of their correction with respect to the current events.



And to be more precise, I "defended" my knowledge in "SvetL" Technology before very strict examiners who also told me those things that N. Levashov and I **HAD NOT HAD TIME** to discuss. I will not touch on all the details of this seminar. I can only say that much that happened after the death of N. Levashov was radically revised and thought over. For example, I got convinced in my own experience that *Man, in his present-day EARTHLY countenance, IS NOT ABLE to move and develop the Space.* But this does not mean that a Man **CAN NOT** do this. With the help of the Friends, I was given an opportunity to "visit" that very "**White Star**", or "**The Abode of Gods**". Then I have not been able yet to make such "trips" by myself. I would like to note for those "writers" and "followers" of **N. Levashov**, who broke into groups according to "their own interests" and today they are nothing but *gaping void of wretchedness*, that I am going to disappoint them. There is no "holographic monument" to either Nicholas or Svetlana. The memory of them is expressed in a different form. **And this memory – lives.**

After the "excursion" I got to know the real truth about what was **under the Levashov's Castle in France.** I was shown how immaterially through two objects (rings) that you see in the photo and that Nicolai and Svetlana had on them there was governing of what that was under the Castle that time.

Levashov, of course, could govern without these "objects", but they made it possible to do it most effectively and, if necessary, – point-wise! Moreover, as it later turned out, they "have been "created" and handed over

to Nicholai and Svetlana precisely for these purposes by those who "had placed" it under the Castle (I call this creation the **GENERATOR OF SUPPLEMENTARY ENERGY** (for the people to have an idea of what it is). Who and what for it has been made – I will slightly open. This is all – *man-made*, as well as *the "White Star"*. For Nicolai Levashov, it was an additional "tool" in his work, **PRESENTED HIM** by those who knew that Nicolai 's hands are reliable hands.



After the acquisition of the Castle and the full information – why and what for exactly this Castle was to become the property of Nicolai (besides the related Svetlana's ancestors), these two objects (two rings), the photograph of which you can see, belonging to **TRUE TAMPLIERS** (not those described by historians with distortions) *were handed over to N. Levashov by Svetlana's relatives*. These relatives are the direct heirs and descendants of those true Tampliers who knew the "secret" of the Castle, but they **WERE NOT ABLE** to use it properly. *Nicolai made up for it*.

At the seminar, in daily talks with Levashov's, Friends I got to know the time and the possibility of my participation in the transferring this creation – *the Generator – from France to Russia*. I also knew why this was necessary and realized that at the **DETERMINED TIME** all this would "come" to me in both tangible and intangible "guises", which would allow using these "tools" exactly in Russia and applying the emerging **NEW RESOURCES** in "**SvetL Technologies** (and not only). Moreover, I got the confirmation of all this when I visited the north of Iran (almost immediately after the seminar in the Alps) in the place where **N. Levashov** had been twice in his time. But that is another story.

Everything happened exactly as I had been told, and today it does not matter in what way these items became "mine" and ended up with me. I'd like to note that other very valuable items belonging to Nicolai "have come up" to me. I knew about their "resources" from N. Levashov, who showed them to me both in the photo and as real things. The main thing is that these items (each one for certain purposes) are already "working" for the good. The use of these rings, not as decorations, but as tools, for example, is an appreciable help in setting up generators for the **New Complex "SvetL"**, "**intensifying**" the Generator (its original parameters) and "**SvetL**"

Programs through direct interaction with **the Generator of the "complementary" Energy** (this is my terminology) which was transferred to Russia, more precisely, to the North-West of Russia.

Everything that is connected with the **TRANSFERRING** this unique man-made (I emphasize – man-made) **CREATION – the Generator "under the Castle"** (from a depth of **1369 m**) – has been realized and allows to significantly influence the processes that the reader already knows about. Regarding the Castle itself, I believe that now this matter is closed to me. I **DID NOT** and **DO NOT HAVE** anything to do with it.



I myself have **NEVER BEEN** to it. Some halls and his study with the library, as well as paintings that were in the castle and sold at the auction in 2016, unclear to whom and for quite a "ridiculous price" (this is a separate topic of the narrative, which I will probably soon disclose), Nicolai showed to me, when we talked on Skype.

Most of all, I was struck with a picture painted by Titian and acquired by Levashov in France "**Tarquinius and Lucrezia**". The picture was painted **in 1535 for one of the greatest patrons of Titian and a friend of Marquise Frederico Gonzaga**, the Duke of Mantua on his personal order. This is one of the most unusual and intriguing paintings by Titian, in which the great master painted a **REPLICA** of Gonzaga's face as the face of Jesus Christ. And later, I saw the documents for this picture, which confirmed the genuine Titian



After the death of Levashov, due to certain circumstances, my friend and adherent **Alexander Kalenyuk**, was in the castle several times, he viewed the castle and captured everything in the cinema and photo documents in sufficient detail. He saw all the paintings that belonged to Nicholai and Svetlana, before the auction. I have this material and it is more than enough. However, after the auction for the sale of property in the castle, which, as I said **was held in 2016**, the Castle today is of interest only as a historical building, and **NOT MORE**; it will be realized, at the request of the heirs, at an auction that will be held in France. So, you can see that even this is the justification for moving the Generator to another place.

I convinced myself more than once of the sagacity of N. Levashov. Since June 2011, already under his supervision, there has been going on its activities in Russia and abroad, the organization created by me at the

beginning of two thousandth (historically revived), which I called "**Russian Scientific and Technical Society**" ("**RSTS**"). Many people ask: "Why is this name?" Not in the title is the essence. The essence is in the action. "**RSTS**" is the organization of a group of "St. Petersburg" scientists to solve problems in the field of new breakthrough technologies. Practically, by that time, "RSTS" had fulfilled the tasks, initially put before it. And they did it **NOT ONLY** in Russia. I was about to close it, because practically all its participants, having completed the tasks, began to work in a number of other directions. It was objectively, unfortunately. But the correction that Nicholai brought, after getting to know about my ideas and the story of the "**RSTS**" **creation** put everything in its place. He made me believe that the **ORGANIZATION NEEDED** its **REVIVAL**, further development in working out those technologies that we have already begun to deal with under his leadership. And the process of transformation made a start. I can **NOT** fail **to MENTION** here the enormous work of **Vinogradova Nadezhda Timofeevna**, who, since the 2000s, has been at the very beginning of the **RSTS** creation taking upon herself all the routine and paper work, which was abundant.



On Levashov's insistence, the attributes of the society were developed, and the Sign of the "**RSTS**" Participant became a silver ring (with the symbolism from N. Levashov).

The first two Signs, according to his sketches, of the pure gold, were made for both of us. But after "being in the hands" of N. Levashov, the atomic structure of the metal has changed, and it was **NO LONGER GOLD**. **ALL** the **FOLLOWING** rings were made of silver. The first silver rings (signs) **WERE PRESENTED** to **Nadezhda Vinogradova and Alexander Kalenyuk**. Exactly silver is that metal today on which the "Generator" feels "comfortable".

The Generator is set in the ring with the Programs personally for each owner. They help the Man to open a very broad perspective with his proper development. And, of course, "protection is put in" in the broadest sense of the word (and from the "fool" too). All this was "thought over" by N. Levashov. He insisted that the Sign



should be made precisely in the form of a ring, explaining that "there are words that can be incomprehensible and not perceived in any language, and there are symbols and signs that are" weighty than words ", and for those who are initiated – they do not require any explanation. " Moreover, taking into account the participation of women in the organization, as an additional element **EXACTLY FOR THEM**, a stone (sapphire) was set in, which gave **NOT ONLY** elegance but beauty to the ring on the woman's hand.

The organization was launched on the day when N. Levashov appeared "with his Sign" "**RSTS**" at a regular meeting with readers. This was understood **NOT** by **MANY**, but those who had to understand – they understood. This **WAS** the **BEGINNING** of the "**PRESENCE**" of the so-called "**White Brotherhood**"²⁸ **directly on the Earth**. And with some "representatives" of this "organization" I have the honor to be acquainted.

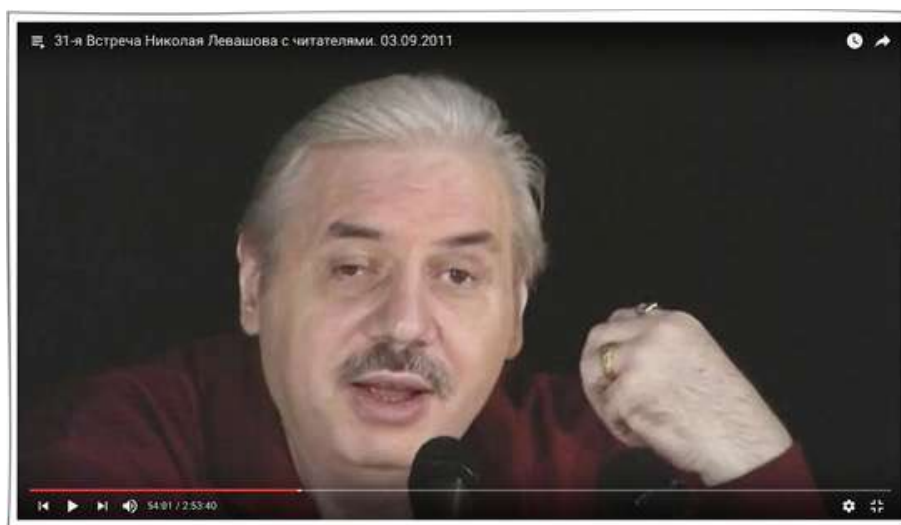

I have told you much of what I got to know. I have revealed some possibilities of applying the "heritage" of N. Levashov, but I am closing with dots more detailed information, because **THE TIME HASN'T COME** yet to make it public. I do not mean the enemies. Who are those who, after the death of N. Levashov, made public what had been "closed by dots" in his works, obviously thinking, that it would give them the "weight of the initiated" regarding the admirers of **N. Levashov**. They opened but **NONE**, until now **HAS GOT AT THE MEANING** of or commented what was "opened" and what it was "opened" for. I am sure that in the very near future

²⁸ "White Brotherhood" is an intergalactic organization, described by N. Levashov in the book "The Mirror of My Soul".

it will be possible to "disclose" this information that will become the **KNOWLEDGE** of the ready to accept **PERSON**.

.....²⁹

4.5. The root of the problem

Outlining this information and understanding all the specificity of the topics touched upon, first of all, I address it to those whose goals are **NOT LIMITED** with the framework of this world, but expand to the fields of, let's call it, metaphysics. I do want *this information to become basic for many of you*, the one which would push off further, if, of course, there was a desire. I deliberately "simplify" the information from **N. Levashov, A. Khatybov and the Research Institute of the CPS** (the Centre of Preventive Strategies) making it, in my opinion, more accessible to the reader. However, it is impossible to give such **BASIC INFORMATION** to the majority through logic. Even the most simplified text, many of the readers forget and return to their subconscious settings the next or in a couple of days, – not because they find some logical inconsistency, but because the information contradicts the existing subconscious settings. ***The unconscious is stronger than the conscious.*** But I do want to hope that the conscious will become stronger if the Human himself wants it. Therefore, I will persistently write it again and again, but on more expanded information. I **DO NOT HAVE DOUBTS** that people who are now participants of "**SvetL**" Programs will get a deep look into the essence of the written. But so far there are **NOT ENOUGH** of them, and if the others get interested in this or that way – ***there will be a breakthrough.***

However, we have to go on with the narrative. The most complicated true Construction of the entire **LAYERED STRUCTURE** of the Atmosphere before the intervention had contained such a complex of energy gratings under which in each layer there had been its complex set ("recipe") out of the group of energies frequencies from **12 to 224 octave**, mainly and even with some individual elements up to 512 octava (only out of the Di-structure). This layer-by-layer energy Construction of the Atmosphere Gratings **PROVIDED** the **FORMATION** and retention in the given program harmony all the specifically necessary variety of the progressively

²⁹ Not public for the time being.

developing harmonious being of energies ***in their non-material and material states***. For all that, gradually and strictly with respect to the given tact of event-driven time and the framework of the general chronoprocess, the process of improving the energies being as a whole and harmonious with it, the **DEVELOPMENT** of the **MIND** of the Earth and the **MIND** of the **HUMAN** occurred.

The Mind in itself is not something vague and formless, i.e. unconstructive, uncontrollable and non-systemic existence of energies being. The **Mind** is also a complex of a special functionally different being out of all possible limits suitable for controlling octaves and energies states over the energies of other octaves and their states, with reference to each specific stage of the Civilization development. Template-machine, i.e. certain mechanical "computer programmed" or limited mathematically-systemic approach to methodological forms of perception and attempts of judging the Mind in this case is unacceptable. It (that is, the Mind) in its development acquires the same **STAGE-BY-STAGE PERFECTION** of such Programmed functions and abilities of Controlling all development processes of the Civilization in general, which **IT HAS BEEN INDOWED WITH** as far as the model formation of the Earth planet. It has the properties of control and self-control, as the well as functional abilities of the Control, the conditions of various forms of contact, including the individuals (that is people), objects and the Control and Support complexes, transmission, reception, decoding and storage of information and the inherent conditions of a completely different level of ***of "Life" definition as the form being*** and the state of the complex out of the whole "set of energies" as a programmed true essence, acting as the leading orientation and control over the "correct" Civilization development as a whole. This is absolutely **NOT SPONTANEOUS**, but a concrete objective and pre-oriented **TARGET PROCESS** of the development of methods and forms of governance, which are only being perfected with each stage. **AND THE MOST IMPORTANT** – ***The Mind is material, since part of the Mind construction of our Planet is composed of the "matter of magnetic energy" within certain limits of energies octaves!*** Moreover, this matter has the ability to move and at the same time, it **DOES NOT HAVE** any obstacles in its movement, the speed of such a movement is many orders of magnitude higher than we understand and compare with the speed of light (photons). Understanding this, **GAVE ME THE RESOURCES** to start "experiments" with the "impact" on specific objects, including people, first through the Complexes, such as **"SvetL-Flora"**

Complex, and then directly with the Brain of a certain Person, concerning his recovery. For me it was a great victory. But this victory would be **IMPOSSIBLE**, as I see it, without my acquaintance with Nicolai Levashov.

How can the lower comprehend the higher? The question seems to have no answer. Not exactly, because the lower can comprehend everything only with the guardianship of the informational support, governance and control of the higher state. This should be referred to **the "SvetL" Programs**. We should also answer the previously unanswerable question: **how can the Brain comprehend itself?** It is also able to comprehend exactly itself, but only if parts of its constructive functions (less or more is not important) **ARE CHANGED** to a **HIGHER-OCTAVE** level. This is not a state of some flashing or forerunning some scientific discovery, it is a much more perfect state of the forthcoming change in the level of the whole Brain octave. This is still ahead of those who are directly integrated into the future. Would you like to check it out? Mentally ask yourself the question – **"WHO AM I?"** Immediately all emotions will go away, because the Brain will come into "stupor". It is unable at the current level of octaves to answer the question to itself – **WHO IS IT?** But **the Mind** has to be "turned on", which will make it possible "to receive" direct information from the Control System, which, in turn, affects the increase of the Brain octaves. So everything, as you can see, is interconnected. And if you are a user of **"SvetL" Programs**, there is a great chance of what we have already talked about – you will be "taken" **to the Bath**. There you are going to "be sweated" and "washed..." This is a kind of some useful deviation in the judgments.

It is good enough to ask questions of an unusual sound for the science, – what kind of Mind could the interventionists impose on our Planet? In what way and what kind of constructive and functional orientation did they develop it? What kind of Mind did they put into people and with what subsequent program objectives? What for did they **NEED** people **IN GENERAL** and exactly with **THAT KIND** of Mind, that was imposed? I will try to answer these questions, but first of all it is necessary to have some information about the Interventional Atmosphere Construction, which played, in this respect, **QUITE** an **IMPORTANT ROLE** in their "Created World", which basically provided the environment conditions on the Earth, acceptable for **"interventionists"**.

This part of the "Created World" both in religious and scientific dogmas is **MORE USUALLY** defined as **certain apophatic Heavens**, which really possess a huge set of not only certain mixture of gases

supposedly necessary for life and miracles occurring in them, but true majestic mysteries that are not known to this day.

It is quite enough to enumerate such, until now unknown, speculative manifestations and effects of physical processes in the Heavens, **NOT PLAYING** a leading role in the destination of the "Heavens" in general, like thunder and lightning, the northern lights, the origin of systemic and non-systemic air streams, rainbow, precipitation, sounding and intimidating rumble, which appeared now in certain regions of the planet and so on.



Let us return to the consideration of the arrangement of the true Construction with respect to an incomplete set of all previously set in functions on the Atmosphere layers. The fact is that this issue is a very narrow specialization in the processes of the life being Control on the Earth as a whole, which significantly affects the essence of the transformations in the near future. Therefore, **IT CAN NOT** be published in the conditions of the remnant aggression, as a complex interconnected **STATE** of the **PART** of the imposed functions of the Brain of individuals ***with a certain genotype of the Brain***, making up the former level of Consciousness of some people of the present time in auto-motor style who carry in themselves the imposed vices and violence.

What is offered to readers about the Construction of the Atmosphere is only **SOME SUPERFICIAL** component of the general knowledge of the **NOT HAND MADE "the World Created"**, limited by the scope of the explanations given.

4.6. Understanding

After the seizure of the Earth the structures of the energy gratings of all the Atmosphere layers were **BASICALLY CHANGED** by the interventionists due to setting in the "imported" energies base octaves and their own accepted forms in arranging energy gratings, but only in the range **of 15 to 128 octave**. The fact is that in the general interventional escort, as I have already mentioned, three moons arrived. But with the self-destruction of the Planet **Phaeton**, the most perfect two were eliminated. For this reason, the ultimate of the "delivered" octaves of the basic imported energies was limited. Within these limits of energies octaves **THERE WAS COMPLETELY DESYROYED** the entire true (child-bearing) constructive filling of the energy gratings **in the Di structure and replaced for a cubic one, i.e. K-structure**. But **from 129 to 224 octave** the true original base energy frequencies in all the Atmosphere layers remained in the former structural state (**Di-structures**) as a fact of inaccessibility in their elemental construction due to the limited technological destructive possibilities of the interventionists. However, for all this time (**i.e., over 18,000 years**) the potentials³⁰ (potential density) of the frequencies in these true energies octaves (**129÷224 octaves**), **NOT BEING** in the maintained state of energy "recharge", were approaching zero and **by December 2012** would have disappeared (collapsed according to the plans of the Interventional program), and the Atmosphere structure after this destruction would have to contain **only imposed k-structures up to the level of 128 octave**. This would have become the irreversible finally captured state of the Atmospheric Construction, in which case the Earth would have actually carried out its self-liquidation in general. I'd like to note that **"SvetL" Programs** as well as **the Generator** itself, after their "creation", also required **SOME ENERGY "SUPPORT"**, because all of these "were created" in the previous Interventional energies octaves. This support was implemented first by **N. Levashov** himself (that is, he himself created this "replenishment") then the so-called **Generation Matrix** (creation) of the Generators left by **N. Levashov** for direct application. But the Matrix's capabilities are limited (and the Matrix itself required "replenishment"), and the number of "having created" and "being created"

³⁰ Generalized characteristics of the interaction of charges in the investigated region, with the charge of the energy imposed on this region of the octave. It is impossible to measure this parameter with the instruments of modern science.

Generators – was growing. This was one of the reasons for the transfer of the "Energy" Generator from the territory of France to the territory of Russia. It was under this action that a **NEW COMPLEX "SvetL"** has been created, which has shown its excellent efficiency today. But we will not be led away from the point. All information about the fantastic "horror in Hollywood scenarios", symbolizing some "apocalypse", really through different representatives (mainly individuals of 423 and 441 genotypes of the Brain), was broadcast earlier by the Interventional System during the last several centuries as a kind of providence of various Armageddon. And this process of the Governing Support has also been eliminated now. Scenarios of "the end of the world" are in vain. And the very process of eliminating the intervention consequences in part of a new arrangement for recreating the Atmosphere energy gratings and bringing it back to the previous one, i.e. "virgin" state, is taking place without their interference and not in line with their will and diligence. But according to the true scenario, this process is going to be even much tougher than the fantasy frames of their crafty "filmmakers" – the apocalypse is not only **STARTED**, but **HAS BEEN UNDER WAY SUCCESSFULLY** at an increasing pace. Inessential part of its manifestation, i.e. its occurrence in the material states of energies octaves is being observed and will go on to be observed by people during the entire Transition period.

The layer thicknesses of the Atmosphere were also changed for all the basic parameters adjusted by the Interventional System for the appropriate arrangement of the Construction from the k-structures with the introduction of only their communication frequencies, which could ensure, among other things, their own steady controlled information contact with their planetary satellites, the Moon and the Sun, i.e. with all of its fleet of planets. In addition, all the technical development of the Interventional System was accompanied by the introduction of such newly set in frequencies into those layers of the Atmosphere in which there had to work **ONLY THEIR** "technical system of translation" of energy-information support of their entire controlled and organized being of energies, as imitating the development process of **ALLERGEDLY CIVILIZATON** of the Earth as a whole.

Moreover, in the original (native) true layers of the Atmosphere, additional, specific **TARGET CONSTRUCTION CHANGES** were imposed. For example, with their help, all conditions were created for receiving tritium from the satellites of the planets (as from the transported

"warehouses" so necessary for the operation of their objects and complexes) as the only acceptable form of energy consumed by them.

In addition to receiving such a form of energy as tritium, another thing was important, too. Tritium needed to be transformed, stored in acceptable energy states suitable for using it and dispensing for both objects (including conventionally called UFO), and for biostructures, namely, those that **only** they (the invaders) managed to get them materialized for their plans and for their subsequent program needs. It was through the use of such necessary brought and transformed tritium that there was **IMPOSED** an **OVERALL PROCESS** of reincarnation of the entire construction of the energy information arrangement and the state of all kinds of water on the Planet. And through the altered complex state of water there followed the **MOST SIGNIFICANT CHANGES** in the formation, support and Control of all the complex conditions, without which the existence of any life on the Earth could not have been possible. And this is far from being all that was affected by the modified Construction of the Atmosphere gratings in all its layers. All together – it was already **NOT** that **TRUE "the World Created"** that has changed and distorted everything on our Planet. Despite that serious constructive changes with the Earth, **IT HAS SAVED** its position in the Common Hierarchy of the Planets of the Intelligent Orientation. But in reality there had been a **PROCESS** of **"IMITATION"** of development of its civilization for ***the past 18,000 years***. This conclusion suggests itself.

4.7. Variations

It is necessary to note an additional, but very important, point. The changed Atmosphere Construction was also to be such an environment in which **VARIOUS MOBILE** ground and sea placement vehicles brought by the Objects (so called UFOs) could be provided (i.e., energy attended) and freely transported by the Objects, the so-called **UFOs** performing part of the Control function of the Interventional System for **ALL** the resultant **PROCESSES** and **ENERGY STATES**, in the material world, too, including the entire biological environment. Such different types of UFOs used only tritium as their "fuel" when taking off, placed in the same medium, and moved only in the Atmosphere gratings (in the medium), which had to

be built on the basis of k-structures. ***In a different grating construction, they could not move.***

MAIN STORAGEES of the imported tritium were placed in large fresh water contents (mainly in lakes) and dosed into the Atmosphere gratings, ensuring the level of its required state. Tritium, which is in an unbound state in sea water (the Hydrophone layer of the Atmosphere), played a completely different role, but for a sea-based **UFO** was applied. Sea Water tritium was used in large quantities, in particular, by the Control Complex located along the eastern coast of the United States and Canada (the Bermuda Complex of the Interventional System). Its delivery was carried out with the help of the **CONTROLLABLE OCEAN STREAM** (current), which oceanologists called **the Gulf Stream**. This ocean current was ***finally liquidated in 2011 in order to localize the actions of the Bermuda Complex*** with its further elimination.



In addition to this, the Earth, with its entire energy capability, was also a unique by its power and **UNIVERSALITY GENERATING** source of energy. It was "forced" to provide its energy resources of the generating complex states, providing the transfer of the energies of individual octaves for the operation of various Intervent Complexes on the Moon, the Sun, and partly on the imported satellites of the Planets. In order to transfer a large volume of such generated energies and to organize communication with its "forced consumers", a special Atmosphere Construction was also required, **CAPABLE** of **MAKING** the Earth generate energy, accumulate it and at the command promptly "transfer" it. And also take its return part back in the modified constructive state and distribute it among the Intervent Complexes and Objects located on the Earth.

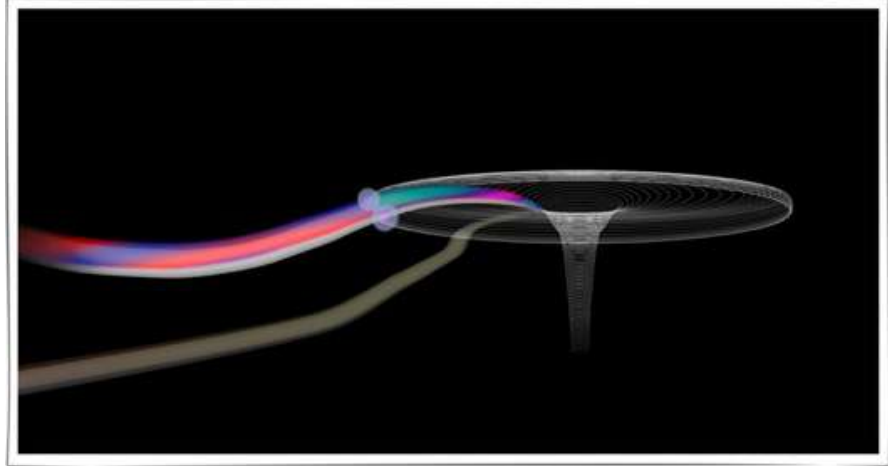

The knowledge of this was, in my opinion, the forerunner in creating **the Generator of "complementary" Energies** (I mean the Generator that was "handed over" to **N. Levashov** in France) transferred to the North-West of Russia by those who saw far ahead and the forerunner of the created by N. Levashov **"SvetL" Generator**. The functioning of the "Crown of the Sun" as the Atmosphere of this Planet, was, to a greater extent, due to the transferred energy from the Earth (in 54 octave). And the energy partially returned from the Sun (in the octave 54.25-54.35 + the mantissa, as the radiation octave) provides, among other things, "illumination" of our Planet, again with the help of the gratings Construction of the changed Atmosphere. This is not a complete list of the imposed functions that were executed with the help of the supplemented Atmosphere Construction.

I'd like to note that the northern lights are a phenomenon of the physical process, connected with the above-mentioned transfer of energies. More precisely, this is the process of afterburning of "surplus energies", previously annually for eight months specially accumulated, but left after the completion of the process of sending to "consumers" (through the **Ural Control Complex**). To store such volumes and in such conditions of energy in the Atmosphere gratings for longer time was impossible, and was not foreseen by the Interventionist System. Therefore, they had to be "burned" as **UNREALIZED SURPLUS**. So irrationally was the energy generating power of the Earth used. This is the true essence of the physical annual phenomenon (in the past), fascinating picture – "Northern Lights!" This is **NOT** the **ONLY** example of the irrational "management" on the part of the interventionists in the application of the Earth's energy potential, connected with the peculiarities of the imposed Atmosphere gratings.



In general, this complicated process of substituting the entire Construction of the Atmosphere's energy gratings in their true state for a foreign one (imposed) was **PRINCIPALLY IMPORTANT** for the Ebr System. Exactly through such changes that other habitat conditions were arranged that were necessary and suitable, first of all, for themselves, and subsequently for all those who they were able to adaptively materialize, including the people **THEY NEEDED** in the period after almost **COMPLETE ANNIHILATION** of all living things on the Earth.

It should be noted that the Interventionist System needed people in the **UNIQUE IMAGE** and surprisingly perfect Brain design, out of which it would be possible to create exactly what would be suitable and acceptable for themselves (the Interventionist Ebr System) and their further program objectives. Moreover, the Brain of the Control System, created in their own design, as a necessary set of governing their imported Complexes, Objects built on invaded territories by the Systems, the arranged communication between them, located in the **layer -4400 ÷ -2200 m**, – **ALLOWED** them **TO SERVICE** and attend only such state of the Control of the organized energies being, which the interventionists had imposed under their Programmed goals and intentions.

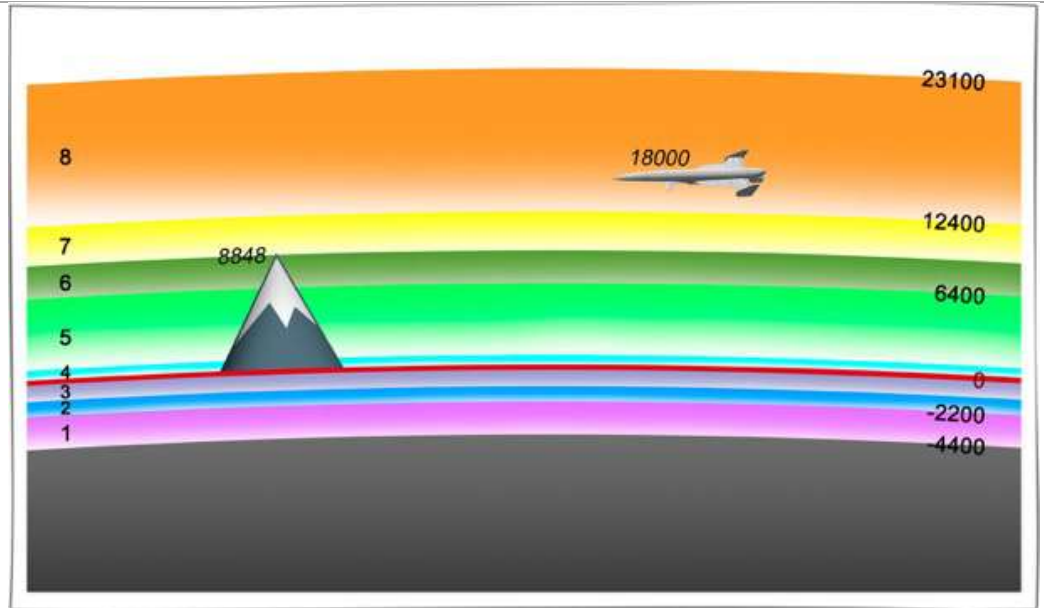

This condition and the state of the entire Control System, especially in the processes of energies being, including the development of the entire biological environment, **PREDETERMINED PUTTING** people's executive functions under the state of the imposed **MATERIAL (consumer goods) APPLICATION**. This state of material application of people attached the entire process of development their Mind **STRONGLY RESTRICTED** and isolated from the truth level and direction, dosing the information process of knowledge in relation to **ONLY INTERVENTIONISTS** general programs: *"Energy informational development of the Brain Genotype and the Development of the energy biogenesis of the flesh."* In that way the development of all the programmed processes of the imposed Interventionists Civilization was arranged and implemented, dividing its single chronoprocess at certain stages of the event-driven time.

All communication with the entire control filling for the external contact (satellites of the planets, the Moon, the Sun) was carried out in the model scale of the Earth, but only for the purposes of the Interventional System functioning, and only for its programmed development. Any other development process had been **VIOLENTLY SUPPRESSED**, and everything had been strictly controlled. For a number of reasons related to the unwilling preservation of a number of functions of the former (Interventionist) Brain Control System in order to ensure smooth adaptation in the transition of energies being to the new state, some of the **LIMITED**

INFORMATION is provided here, with the main emphasis on the functional purpose of the layered Construction of Energy Gratings. The information of the table partially demonstrates what kind of layered structure the Interventionist Atmosphere Construction has turned out.

The main layers of the atmosphere and the changes taking place in them as the elimination of the consequences of the intervention

1	-4400 M -2200 M	The Atmosphere Brain communication grating, location of the Atmospheres Brain	128 octave
<p>In this layer there were placed all the Complexes and Objects of the Interventionist System, as well as its Energy “Cords” and the voluminous structures of the energy interaction of the Complexes and Objects. Besides the Control Complex Alps 2, which will be removed after completion of the reconstruction in the 0 ÷ 1200 m layer, and Ural, which will be removed after the completion of “the Black Sea operations”, all the rest are already completely neutralized with the liquidation of their Programs, and the Objects themselves are put in dead storage. Most of them are liquidated (earthquakes).</p>		<p>The speed of the signal is equal to the "speed of light". The layer is completely blocked against the activity of Interventionist Objects and Complexes.</p>	
2	-2200 M 0 M	The hydrophone layer	88 octave
<p>The Atmosphere Control System was simultaneously located here.</p>			
3	-1280 M 0 M		88 octave
<p>The layer of water 1280 m thick was “thrown” down to make The “Flood”. There is only one type of grating in this layer but the water properties are different. The layer is to be liquidated during the transition period. and water surplus is to be energetically destroyed and the energy will be thrown into the Space (tornado, and so on)</p>			
4	0 M 1200 M	Base layer	63 octave
<p>In the layer there were conditions for the existence of biostructures materialized by the interventionists. For today: 33% P, 33% GP k-structures and 66% P, 45% GP in Di-structures. From 2011.01.07: 11% P, 11% GP k-structures and 100% P, 122% GP in Di-structures. Since 2010.12.30 the Program "Elimination of robots" and most of the materialized biostructures has begun.</p>		<p>P is the density of the electric potential charge, GP is the gravitational potential density of the charge, Os (187) is ready for elimination.</p>	
5	1200 M 6400 M	The accumulation layer	65 octave

<p>Main functions:</p> <ul style="list-style-type: none"> - the main layer of tritium treatment. All material structures of water are formed in this layer; - the layer (was) for the frequency of channels to transfer humanoids (for individuals 4xx of the Brain Genotype and other biostructures); - in the layer there are frequencies of the tritium bond with the oxidizer (structures that have the ability to bind only tritium), called oxygen. <p>For binding and water formation only O₂₁ is used. The latter comes from the Earth, it is created by decomposition of lithium (its reserves are completely concentrated in the desert);</p> <ul style="list-style-type: none"> - a grating with frequencies filtering signals is formed in the layer; (only certain frequencies are let to pass, it is an isolating medium for others); - the control of tritium accumulation. At its concentration above 122% it is destroyed to 0% by the formation of lightning. Ozone – the disintegration of not burnt tritium. For 2010.12.30 the content of tritium in the layer is 11%, which corresponds to 4-5 meters of snow. Lithium is made by the Sun, regulation is in the channels of the layer (Complex Ural). The content of lithium can not exceed the content of tritium. The receipt of O₂₁ from March 21 until December 21. The formation of water and snow is regulated by temperature; - the layer has a reference frequency of 65 octave , all humanoids 4xx came into the layer. Today there are no more humanoids in the layer, they are all thrown into the Space through the channel. Reincarnation, as the Interventionist Program, is eliminated forever! - the layer has the entire range of frequencies from 15 to 128 octave. Since 2010.12.30 there have been 33% P and 33% GP k-structures plus 88% P and 88% GP Di-structures in the layer; 	<p>The maximum wind speed is 127 m / s (457 km / h).</p>			
<table border="1" style="width: 100%; border-collapse: collapse;"> <tr> <td style="width: 20%; text-align: center;">6</td> <td style="width: 40%; text-align: center;">6400 M 8800 M</td> <td style="width: 40%;"></td> </tr> </table>	6	6400 M 8800 M		<p>61 octave</p>
6	6400 M 8800 M			
<p>- The reference frequency of the 61 octave layer (used for the Program Performance Control by all the individuals of the 4xx genotype of the Brain);</p>	<p>The maximum wind speed is 224 m/s (806.4 km/h). The whole system of Humanoid communication in this layer</p>			

<p>- has structures (garlands), providing work in octaves 21 ÷ 77. The remaining octaves have channels of passage through the layer; - All robots 4xx had a reference frequency (<i>when making biostructures</i>) of 61 octave. If it is removed, the robots will disappear (<i>annihilation of the flesh of the body</i>); - the layer was the main one for storing all kinds of insect humanoids (including those that were created before 0 year). By 2010.12.30 all humanoid insects had been thrown into Cosmos, 45% of structures in the layer have 0% P and -123.99% GP k-structures. The layer has 12 types of structures for the organization of broadband communication;</p>		<p>is completely eliminated. The process of complete stripping for the information contact with the “Konactors” individuals.</p>	
7	8800 M 12400 M	The layer of materialization	
<p>In this layer materialization of UFOs took place after their ascent through the "Lifting Tubes". <i>Their liquidation since 2010.12.31 during the transition period is final.</i></p>			
8	12400 M 23100 M	Atmosphere protection layer	Up to 512 octave
<p>Formation of "anti-gravity", the re-creation of the former "Protection"</p>			
9	23100 M 62400 M	Special Information	Up to 512 octave
<p>Formation of anti-gravity", the re-creation of the former "Protection"</p>			
10	62400 M 127600 M	Special Information	Up to 512 octave
<p>Formation of a new state of protective layers from external influences</p>			
11	127600 M 450000 M	Special Information	Up to 512 octave
<p>Formation of a new state of protective layers from external influences</p>			
12	450000 M 1284000 M	Special Information	Up to 512 octave
<p>Formation of a new state of protective layers from external influences</p>			

The functional features imposed upon the main layers of the Atmosphere can be briefly expressed as follows, without adhering to a consistent hierarchy in terms of their significance.

In the construction of a special Construction of the energy gratings of the Base layer No. 4 (0÷1200 m), all energy frequencies within the range of 12 to 224 octaves are applied, the harmonious Controlled being of which and the process of Control of such energy being together are an integral part of the basic formation that are defined as controlled **"Habitat conditions"** for **ALL** biological **STRUCTURES**, materialized by the Interventionist System, including people.

The habitat conditions for the biological sphere is a process of integrated Control of all elements of life, including executive actions, at whatever level they are incarnated (including rabbits, the density of reproduction of which were so diligently engaged many scientists in their studies).

Despite the fact that this sounds somewhat pathetic, and this should be emphasized, as if it were, from positions that are superficially based on religious dogmas, but really **"everything and all thoughts and deeds are performed in Heaven."** Within the framework of precisely these **ARTIFICIALLY IMPOSED CONDIDIONS** for the life existence, which we observe nowadays, the entire Control of the biological existence in general had been put in, and precisely from this layer of the Atmosphere, that is, through it and with its help. **"SvetL" Programs** in matters of recovery and "interaction" with the Brain are also "working" within this layer of the Atmosphere. But this is only in matters of "recovery".

Here they are, the "Heavens", specially equipped by the Creator. This is **NOT** the **ONLY**, but an influential part of the general set of elements of life support on the Earth, as such. Therefore, to the "Habitat Conditions" as the process of Control, there are also complementary but not less important elements, the functions of which are partially invested in other Atmosphere layers and even beyond, as providing and attending ones, including communication with the Moon, the Sun and the Planets satellites. All this should be referred to the **Programs "SvetL"**. It could not be otherwise, because the Generator, created by **N. Levashov**, is "inscribed" in all these partially covered processes. And **IT GOES WITHOUT SAYING** as far as **the Generator of "complementing" Energies** is concerned. Now the physics of the process is supposed to be objectively understandable.³¹

Such are the providing functions of the imposed life-support on the Earth, which are partially endowed with other layers of the Atmosphere, namely:

- governing their harmonious states through Complexes and Objects, including the Control of material and non-material states of the gas layer;

³¹ Physics (from ansient.-Greek Φύσις) – Nature.

- providing the carrier medium of energy-information translation to make governable the vital activity of living cells and their performance of strictly differentiated functions;
- providing the Programmed executive actions or realization of the individual functional allotment of each biological individual;
- energy support of their functional organized existence, all kinds and ways of reproduction;
- the functioning of the Brain;
- providing passage corridors for **α -**, **γ -** and **β -photons**, as an integral attendance of biological life and much more.

All this is associated in a single concept, which is positioned as the Controlled "Environmental Conditions".

If you carefully "get at the deep meaning" of "**SvetL**" Programs, then this is, in a way, **PERSONAL CORRECTION** of the environmental conditions, and basically – the life support system of a specific Person (the User of "**SvetL**" Programs). Thus, the Habitat Conditions and Conditions of the controlled environment are **NOT** the **SAME** as they are often confused in the current scientific and secular circles, and specially "**SvetL**" Programs. I will not detail their operation and application in relation to the owners in this aspect, since this is a highly specialized issue, which is **RATHER SIGNIFICANT**, because there have been all sorts of attempts of aggressive intent and even technical interference in these processes. They were unsuccessful, but they brought **SOME TROUBLE** mainly to those who, out of curiosity and selfishness, decided to "make experiments" with the Programs, absolutely **INCOMPREHENDING** neither the physics of the process, nor, especially, their purpose for the environment (the environment of their own life-support). But it's about **the Programs**. And as for the Atmosphere layers nowadays there are quite enough consequences of the "exploratory inquisitive activity" of insane professionals from the territory of Alaska, blindly generating technical and energy impacts of an aggressive destructive nature on the Atmosphere layers. By the way, it does not remain without consequences over the territory of North America. So let them "try" for others, but nature will also "reward" them!

It is necessary to note a very important circumstance – the state of the current natural Habitat and Conditions of the controlled environment are subject to a very **ACTIVE RESTORATION PROCESS** and **UNAVOIDABLE LIQUIDATION** of all those consequences that are connected with the past Interventionist distortion of the true Construction

of the Atmosphere grating with respect to **layer No. 4**. With all this, no common administrative, scientific, religious, as well as any individual decisions and opinions on the part of people are not taken into account, no matter how "important and meaningful in terms of their acceptance" they are.



It is important to understand that changing the natural habitat and the conditions of a controlled environment entails the necessity of changing the entire Structure of the organized people's being by means of the **ELIMINATION** of the **OLD ONE** and the **INTRODUCTION** of the **NEW** Construction. This is also inevitable because of the constructive changes in the Control and attendance of energy being in general, as well as all other consequences and changes out of the ongoing processes of the complete restoration of **Layer No. 4**. It does not depend on the opinions and any decisions of administrative structures from staff of the present dominating level, *especially in matters of preservation the present world order*. The time of eventful processes of people's being earlier defined by the imposed basics of "the benefits and satisfaction of the personal interests of an insignificant minority on the basis of violence and parasitism over the prevailing majority" **HAS BEEN OVER** and is **NO** longer **ATTENDED** by the new Control System. "Time of Reason" has come. And this is a completely different basis, first of all, for the formation of the **NEW WORLD UNDERSTANDING**.

4.8. The approach

The present Atmosphere layer (**No. 4**), with all its complex functional allotment, not only provided the **BIOLOGICAL BEING** of **PEOPLE**, but also served as the basis for the translational support for getting all the information of the cognitive and governing character provided by the System as an objective necessity for their comprehension of the objective surrounding reality. Consequently, this layer by this most functional governable presence in a program-defined degree influenced the formation of a **STEP-BY-STEP DEVELOPING** individual and public Consciousness as the basis for all subsequent programmed executive actions of people.

In what way, then, does layer 4 participate in such a complex process as the formation of Consciousness as such one? This layer is a **supercluster system** of the local-target Control for the formation of the **SPECIFIED PROGRAMMED** habitat **CONDITIONS**. It combined a number of some functions, namely:

- receiving and retaining information in a stable, indestructible state for a certain period;
- target orientation for the further identified translation for people;
- recycling of the worked out information;
- making an information structure from elemental components to a more complex one, and much more.

BASIC ENERGY OCTAVE for the construction of this layer grating **is octave 63**. It was the base octave of the Human Brain Control for **the entire group of individuals with 4XX Genotype of the Brain**. Simultaneously, it was within the limits of the frequencies of the same energies octave that a certain significant part of the **so-called external Control System** on the side of the Control Complexes and objects occurred that affected the activity of most non-reductive³² functions of the Human Brain. In addition, **TWO STATES** of the Human brains, namely, **the antineutrino and neutrino**, are structurally arranged so that the basic basis for such an arrangement of energy gratings in the constructions of these brain states is the same **octave 63** with its identified mantissas, which ensure the possibility of not destroying the format of the information received in the same octave. In this there is nothing accidental. The

³² Not weakening, constantly necessary for existence.

availability of these three very important basic circumstances provided, in the main, the complex process of the entire Control of the people's being, including the formation of the Consciousness. All these proceeded in harmony with the tact of event-driven time within the framework of the general chronoprocess as the formation of a kind of ***energy-information cluster module with a temporary stability for a certain moment*** (in the sphere of the antineutrino state of the Brain).

The formation of such an individual or collective peculiar cluster information and control module on the basis of the acquired information of cognitive and executive character as the Governing start for all further executive actions of individuals or groups of them is the **ESSENCE** of the **CONSCIOUSNESS FORMATION**, both individual and social. Subsequently, it is from this constructive state of the Brain that all further Control of the executive actions of the individual through his proton (material) part of the Brain is translated. The physical action of this is realized in the form of energy-biochemical processes in his environment and in the medium of the **OPERATING FLESH CELLS**. The last phase, or stage, with the help of technical means and various control methods, is observed by many researchers who are keen on the problems of the Brain functioning with different aims. Thus, in that part of the Brain that can be accessible to people for their "exploratory and experimental actions" (proton, that is, the material state) – **CONSCIOUSNESS IS NOT FORMED**, but ***only its directed resulting form of influence by the individual for subsequent executive processes and actions is realized.***

But the process of the general energy-information translation on the side of the Control Complexes and Objects **IS NOT** that only "miracle-working" that formerly formed the people's consciousness. There was also a need for communication, as a complementing information accompanying programmed fragment, but who with and what with? The Control Complexes and the Objects carried only the executive function, and the Programs of the conceptual level **WERE NOT ABLE** to form. In order to ensure the reception of the information of the programmed nature from some information sources of a **HIGHER LEVEL** of governing from outside, a specific layer of the Atmosphere was formed. Such functions were endowed with the **Atmosphere layer №6**. Briefly about it..

Separate multileveled functional value had the layer of the Atmosphere Contacts **No.6, 6400 ÷ 8800 m.**, in which the Interventionist System formed ***12 main types of its imposed contacts***, namely:

№	Purpose of the systemic contact functions	Liquidated	Will be liquidated
1	Contacts of all individuals of 4xx genotypes of the Brain with the Moon. (Placement on the Moon of the program "Development of genotypes of the brain" and its translation for CC to the Earth).	2010.12.30	
2	Contacts of individuals 441, 442 of the Brain genotype with the Sun (Placement on the Sun of the program "Energybiogenesis of the flesh", its translation to the Earth via CC, the subsequent functional allocation of individuals taking into account the genotypes and their geographical location).	2010.12.30	
3	Contacts of individuals of 4xx genotypes of the Brain and the satellites of the planets (some fragments of the Control Program "Development of the energybiogenesis of the flesh", including, in particular, the matter of the societies formation).	2010.12.29	
4	Contacts with the Moon: Translation of all kinds of loads for all biostructures (programmed correction of functions, reproduction, elimination, including diseases, performance of "album" records).	2011.01.02 (Start)	Until April 2013
5	Contacts with the Moon: Specialized target forms of the Programmed information for 4xx genotypes of the Brain. Governing the executive actions within the current Vector of Target, phenomena, actions and events. Introduction of "Album Records" for performers with 4XX genotype of the Brain (since 2005).	2011.01.01 (Start)	2012.04.24
6	Contacts with the Moon: The Programmed target information for Complexes and Objects. (Formation of strategies for common Programs, Vectors of Target within the framework of the Chronoprocess, translation of the Programs for the formation and Control of the Civilization development).	Until 2007	

7	Contacts with the Sun: Specifying the rate of metabolic processes for all biostructures and the tact of event-driven time (1,0007 sec.)	since 2011.01.02	to the end of 2013
8	Contacts with the satellites of the planets: Delivery of tritium from satellites (change of its energy states, storage, distribution and accounting of consumption).	Until 2007	
9	Contacts with the satellites of the planets: Loads for all individuals of the 4x genotype of the Brain (astrology, i.e. its program correction "in the image and likeness", preparation for the subsequent application for the reconstruction of the Brain and its replacement with the Interventionist Brain in functions).	Until 2007	
10	Cotacts with the satellites of the planets: Receiving frequencies potentials on 18 imported basic energies octaves. (Constructional arrangement of the Control, correction of the Programs for Systems and Control Complexes).	April 2007r.	
11	Technical connection with all developed Interventionist systems on the Earth, located above and below the layer. (Energy gratings to ensure the operation of all types of technical communications used by people)	since 2011.12.31	Until the end of 2014.
12	Technical connection for moving all kinds of objects in this layer (movement in the layer, i.e. moving within the layer gratings of all types of UFOs, aircraft, rockets, probes, etc.).	since 2010.12.31 (for UFOs) since 2011.02.20 (for the aircraft)	UFO – until the end of 2012; For the rest, for 3-4 years

The connection of individuals of **4xx (421, 422, 423, 441, 442 and 461)** of the Brain genotypes with the Moon and the satellites of the planets (functions 1 and 3 in the Table), and also for individuals of **441 and 442** of the Brain genotype with the Sun (function 2) were the most important component, out of the whole complex set of the formed Interventionist **"Conditions for the controlled environment"**. They are no less significant as well as inalienable as the main ones, since **WITHOUT THEM**, the very existence and attending Control of all the imposed

processes under the conditions of another life on the Earth taken by the interventionists – just **COULD NOT HAVE BEEN** possible at all, since the true ones had been annihilated. When considering the above mentioned connection, in comprehending its essence, one should not invest only an accepted simplified understanding of it as it is understood by all kinds of current and developed by people **TECHNICAL COMMUNICATION** for everyday life as a complex of organizational and technological measures and actions to transfer, receive and process their information . The connection of all **individuals of 4XX genotypes** of the Brain with the Moon, the Sun and the planets satellites is **IMMEASURABLY DEEPER, MORE COMPLICATED**.

What was provided with the help of such communication, and how much was it functionally important in the overall development of the imposed Civilization and the formation of Consciousness, in particular? First of all, it should be noted that such an interventional connection, but already in the energy gratings of a cubic structure (k-structure), **HAD NOT DIFFERED** in its stencil constancy of its states for the entire occurrence of the event-driven time **(18,000 years)**. It had a progressive **DEVELOPING CHARACTER** of its perfection, dictated by the overall program harmony of the whole process of its own development within the framework of the imposed Interventionist Civilization. Strictly in harmony with the imported tact of event-driven time, there had been a **CONSTANT** process of **COMPLICATING** not only the essence itself, but also some kind of "technical perfection" of the entire System of the Controlled being of the brought in energies octaves. Even the very construction of information, as it is, had been perfected and brought to the imposed version of a digital basis. People have taken it as the transition to the digital basis of their technological excellence. ***But it is to be liquidated soon.***

There had been a gradual process of achieving harmony of such being of energies, education and perfection of the imposed Interventionist Mind, **STEP-BY-STEP RIG** under the ideal likeness of supposedly "True Civilization of the Earth" and so on. This, as the highest end in itself, had been primarily pursued by the Interventionist System. For without such an artificially created "likeness to the supposedly Civilization of the Earth", the very stay and all efforts to seize the Earth would have been in vain. They (the interventionists) would not have realized their **STRATEGIC GOAL – PENETRATION in the artificially created by them image of the "illusory similarity of the Earth's Civilization"** to the General Hierarchy of the development of Civilizations for the Planets, possessing

living conditions of the Intelligent orientation. A simple penetration into the structure of such a Hierarchy of the planets **WAS IMPOSSIBLE** for them, since they would have been **LIQUIDATED** immediately by a more powerful and perfect "impact from outside." Independently, i.e. without the capture of the Earth and the subsequent illusory civilizational image of similarity, like the *System of Planets of a different destiny*, they were **COMPLETELY ISOLATED** from such a form of perfect development of their own Civilization with the subsequent possible penetration of the whole chain of similar planetary formations into the General Hierarchy of Civilizations in general.

Of course, this is beyond any Hollywood fantasies on the theme of "Star Wars", but in reality it is incommensurably higher than any limits of scale opportunities and abilities of such imaginations by the Brain of people. Especially under the conditions of their being in the **INTERVINED MATERIAL** application. Most of the informational inaccessibility for people, both in cognition, and in comprehending the truth about everything that has been happening, was **ORGANIZED AND ARRANGED ARTIFICIALLY** in such an illusory manner as if *everything had been happening in a natural way*.

Moreover, the Interventionist System, on the whole, possessed an insufficient level of development and "technically laid-out perfection", in contrast to the Planets, possessing and endowed with the conditions of life of the Intelligent orientation.

I have already mentioned in detail that the Earth, being a complex strictly identified planetary monocluster, had all the necessary set of energy-technological complex state (*independent*), but Ebr Interventionist system did not have such a concentrated governing "completeness" on any of its delivered Planets. The interventionists just needed such a Planet as the Earth, also because it was a single interplanetary cluster complex for its development for all the forthcoming *eight stages of civilization development*, and they could create for themselves conditions for their **PROGRAMMED EXISTENCE**. Therefore, the Interventionist blow was **INFLECTED** against the **WHOLE** Model complex. But after this seizure, the **GENERALPROCESS** of self-arrangement began, and not only on the Earth. Therefore, the entire connection, which was re-arranged and formed by the Interventionist System in this layer of the Earth's Atmosphere (No. 6), had a **SPECIAL STRATEGIC CHARACTER**, and its functions, especially of support (through communication) the imposed Habitat and the controlled

environment, were of **PRINCIPAL SIGNIFICANCE**, not only for the primary materialization of people and governing their executive actions in the Program framework, but for the implementation of all strategic objectives of the intervention in general.

4.9. Biological sphere

LIQUIDATION OF THE CONCEQUENCES of the intervention itself is very complex and subtle, but it is basically the **SYSTEM LEVEL** processes, without involving people in it.

In the future, we are going to confine ourselves only to the framework of the formed connection of the Atmosphere layers that were organized to attend the Habitat, the Controlled Environment, and only in the part that directly relates to the biological sphere, including the being of people, as well as the Control of their executive actions in the Programmed processes of development of the **EMPOSED CIVILIZATION** with their violent involvement in all these processes. Everything that concerns Programmed Governing development Processes conditionally called "nature", i.e. Flora, fauna and so on, it is, in itself, **NOT LESS** meaningful, complicated, but also necessary for the existence of people and their cognition of the natural environment in future, if people get aware of living in the future.

Partially I showed the importance of the Programmed connection with the Sun, the Moon and the satellites of the planets, not only on the technical side, but also on its role in the general **PROCESS** of **DEVELOPMENT** of people's **CIVILIZATION** and the Consciousness development, both the individual one and the public, in particular.

First and foremost, it was through this connection that the **COERCIVE HOLDING** of people's executive actions in the state of their material use over all Programmed processes controlled by the Interventionist System had been **PREDERMINED**. And accordingly, this resulted in the step-by-step preventive development of the individual and public consciousness before every historical eventual executive step.

The formation of consciousness was carried out by the practical provision of all the necessary information of a "strategic and current" nature, which for a long or short period were translated to Complexes, Objects and ***the formed Control Systems***. The latter, in turn, through the energy-information translation from themselves, governed i.e. determined all

subsequent conditions of execution and the necessary commands related to the construction, development, functions and the arrangement of the energy-informational translation for people and their Brain development for a long period of their **ALLEGEDLY "NATURAL" PERFECTION**. It was through such Program directions, like commands, that the process of people's development that were materialized by the Interventionist System took place.

This, to a certain extent, is sufficient to understand the importance of the Atmosphere layer 6 itself and the imposed connections through it with the Moon, the Sun, and the planet's satellites. If you look at the history through the accomplished actions and events, then, indeed, there is a **CONFIDENT IMPRESSION** of a sort of the organized sequence of development. People have an unquestionable confidence in the "naturalness" of the historical development of the perfection of their life arrangement. The history of civilization can be expressed in eight words: ***the more you know, the more you can***. But I 'd like to add here that ***the less you know, the more you believe***. **Faith without knowledge is dead.**