

F. Shkrudnev



N. Levashov's
«SvetL Broom»
in A. Khatybov's
«Bath School»

Book 5. Complexity and degree of facility

Life goes on...

Feodor Shkrudnev

Life goes on...

**N. Levashov's «SvetL Broom» in
A. Khatybov's «Bath School» and a
Labour Spade**

**The continuation of the third volume
of the monograph «The Mirror of My Soul»,
not completed by Nicolai Levashov**

**Book 5. Complexity and degree of falsity
(The Bath for simplicity)**

Translated from Russian by Alla Khabenskaya

Saint-Petersburg 2018

Foreword. How the melody of knowledge for the Broom, the Bath and Spade looks like

Power is not in Knowledge but in Comprehension, which begins with Cognition

After another proposal to work with a Spade, take the Broom and try to get to the Bath – new upcoming "calluses" of Knowledge are obvious even for those who have already got used to the tool, difficult to recognize looks of those who are sizing up the efforts of those who work with the tool and sympathetic grimaces who consider this work useless or even detrimental as minimum for those who look. "Antoshka, Antoshka, let's go to dig up potatoes", like the famous hero, "they did not ask them that".

YET. Although there are enough of those who will not be asked **ANY MORE**. They will not take the Book in their hands, and even if they peek into it out of curiosity, this will be their only attempt; however, their shouting about the uselessness of the above will be the loudest. Or, the other way round, they will pretend they do not know anything (even if they suddenly find out), and therefore they will not tell anyone anything (the book, however, may even be hidden under the pillow).



There is another no less noticeable option, born by Beaumarchais: **to pretend that you do not know what everyone knows, or you know what no one knows** – the "significance" of those around them guarantees that the book is not needed at all for this purpose. And while some are shouting, while others are silent, many, alas, believe the exclamations or do not hear them – the shouting are too loud or the silent are too silent. The

habit of thinking with the "given to head" abilities has not yet taken root and was not even intended for the majority; and the "liberated" do not have time to believe in the changes that have taken place for the better – they are too busy with the usual accumulation of everything or even quite unusual "revolt of consciousness". Anyway, it will be gone and is already being gone: The book is not a needle – you cannot hide it in a stack, or in a bag – the information it carries is too big and is just as noticeable to those who made it such. And the Earth Control System does not sleep: a year of its work to return the true states of being and energies is not even equal to two years, but to many ones.

Like the one sliding from the hill – more so, from the "hill of opportunities" (if everyone had time...), to the "top" of which Man climbs about the age of 32, then – head over heels or quietly – according to the "results" of the "accumulated" (the maximum potential for human life support is $12762.768621 \times 10^{18}$ volts/ M^3 , the minimum is $6438.458723 \times 10^{18}$ volts/ M^3). The correctness of the "chosen" method of descent is clear only at the end; however, people were not given any other way out, except to "slide down after climbing". It was even taken into account that it was possible to learn about the dangerous "turns of the track" before it was "conquered", but the information received was very different from the reality, the data on those who invented the "attraction" and its purpose were not presented at all.



The "use" of the elephant, the methods of imposing knowledge and controlling people have long been described and should have been well

studied by the workers; however, the new Book contains many more new pages following its brief introduction, which should also be "dugged up" in front of the door to the Bath (or the dressing room – with any "luck"). It is, rather, not for calloused hands, although the meaning of repetition is well explained by N. Levashov, and a portion of the "pleasure hormone" is unlikely to be superfluous – vital for the body... And more for those who celebrate the Day of Knowledge on September 1^o, and not the ways to it, for whom the book is the source of Knowledge, and not information. After all, Knowledge is generated by the Brain, which stores what has been received with eyes or ears on the shelves of understanding and preservation. Thanks to Chernyshevsky, Rakhmetov, who "read" two books from each branch of human knowledge ("What is to be done?"), seemed knowledgeable, but was not: the shelves for storing information, apparently, turned out to be too empty. Cognition is the fate of the Mind in the current state of Consciousness, achieved also thanks to reading with comprehension, leading in multiples to other levels of understanding possibilities: Man, as it should be known to those who have studied the above, perceives only the information for which he is ready by the achieved level of Development at the moment of opening the book. Therefore, it is vitally important to read books, especially Books that carry information, information about knowledge, its origins, reasons for imperceptions, ways and means of assistance available today to anyone, regardless of the ability to understand the stated today – thanks to them there will be tomorrow, and it will be brighter. And in general it helps. Especially if repeatedly...

Behind all the falsehood of the ongoing around today, there is something greater and earlier in the truth than the result of distortion in letters, laid down in words, sentences, pages and even books – each one who examines an elephant describes it from the heights of his capabilities (the scale of thinking), ideas and challenges. The Truth cannot be subjective – such are only the facets of its Truth. And the phenomenon of all Being, including the living and inanimate, is preceded by **INFORMATION**, the **IDEA of CREATION**, being realized in the Construct of actions through energy gratings, then being clothed in being with the charge on their edges through spending the energy of non-being – for the implementation of the intended, but not for the announcement in the next issue of "news". And the words are an obvious **SECONDARY TOOL OF HUMAN POSSIBILITIES** to describe the Idea, the simplest and most obvious result of the problematic use of which is like a game of princess telephone. Childhood days are over – Midgard-Earth is on the threshold of the second

class of development, which requires different states of the planet and the capabilities of the Brain of those living on it. And future news releases on it will obviously be without the words of the announcer and distortion of the picture by journalists and editors (if at all this news is ever needed), well, unless the "digitalizers" come up with a graphic editor for the brain. But this is unlikely – Brains are not "given" for this.

Behind the falsehood of what happened are the illusions of the supposed future. You can still look into it out of curiosity or avoid meeting other people's plans – it is too much of the bitterness of the past being observed today in an effort to turn the famous wheel back. Illusions are like fog which makes it difficult to "land". Airplanes are forced to circle in search of the coveted strip or expect natural grace, it is more difficult for them – they depend on other people's "whims". It is easier for people – they can already enjoy the freedom that has come due to the change of the Systemic power on the planet, the main thing is to correctly calculate the "accepted" dose (especially in the fight against the past remnants in oneself and "on top"), so that the consequences of eliminating the "bondage of the soul" could not bring to a different bondage. Ustin Akimych ("Shadows disappear at noon"), without knowing it, he has long developed a good mechanism for "dispersing the fog". Its application to the already well-known major September events in the United States seems to be catching and an interesting result for those who will look into the Book, or follow the path "I doubt it, though" themselves, "cutting through" their "window to Europe", and while doing it, keep in mind the wind that will blow out of it, which can turn out to be dangerous for those who follow. And such a Book is not only the best gift, as in general, but also a reliable remedy for harmful "drafts". Its uniqueness is guaranteed in this.

Born in Labor, the fifth book ***N.Levashov's "SvetL" Broom" in A. Khatybov's "Bath Science and a Labor Spade"*** again urges the reader with the Broom into the Bath after Labor with a Spade, choosing for this earlier "missed "places" in the readers' heads and recalling the Scientists who created all these tools. What they accomplished is revealed from new sides by the efforts of the author – Feodor D. Shkrudnev, whose scale of thinking clearly corresponds to the "dimensions" of the problems described and the subjects raised, thereby guaranteeing an undistorted and intelligible



PRESENTATION of the Works of the well-known and hitherto not very Scientists, his great experience, results of Creations, conclusions of what is observed around and not too noticeable – the matter is still "dark" for the majority. And by the efforts of *Irina Barsukova, a talented Belarusian artist*, who has passed through this Work herself, with her colorful illustrations to this Book (and others) with obvious gratitude of the author and, for sure, the readers' appreciation the Talent. Behind the seemingly simple fact of her friendship with Feodor

Shkrudnev is the authenticity of the New Knowledge ideas about the indigenous peoples who unite those living in Russia and Belarus, for whom there are no state borders in the spatial and other unity of the future life support zone, which is now being formed by the native Earth Control System, with the code name "Russia". As for the readers' subjective **PERCEPTION** of the words, sentences and pages on which all the information of the New Knowledge is given, then everyone, naturally, is able to see and understand what they are capable of – negative emotions are inappropriate, moreover, they are detrimental. And all the roots of the current events it is better to see in the mirror. The use of the "SvetL" Technologies guarantees high quality "images" and elimination of the causes of distortion. You just have to learn to wait, as it is recommended in one well-known song, and learn to correctly use everything that has already been created on their basis and still being planned. In the Harmony of Instruments and their Application, the melody based on "*la-la-la*" will immediately change to "*Na-Na-Na*". With all the consequences.

Words of gratitude to the author for the great Work and gratitude to the Creators for the personal responses with the results of the Technologies use. It is welcomed and sometimes even encouraged at the Competitions periodically held by the Russian Scientific and Technical Society.

A. Nikonovich

Introduction

Man is immortal thanks to Cognition.

Cognition, thinking are the Source of his Life, his Immortality.

Man's life passes like a dream. To understand its meaning, you have to wake up. Changes in the outside world are beneficial only when they come from the inner world of Man. Everything that exists and does not exist in this world, – all this is here – in the Soul of Man, his Spirit, his Brain – whatever you like to call it. Cognizing all this as the Truth is the sense of Life.

The main thing in life, as one of the options that we have been taught since childhood: to plant a tree, to write a book, and bring up a son. But even more important is to make sure that your tree has grown, your book is read and your son respects his father. That's what I was proceeding from after finishing the fourth book and wondering whether to write a sequel. The tree planted in adolescence is growing. The son respects his father. And while writing the previous books, I got convinced that they were being read, with interest and by a lot of people. And if they are read and arise interest, then I have to go on telling people what I know myself and what has not been told yet.

If before a pot appeared there had been an idea of a pot; if before the Universe came into being – there had been an idea of the Universe; before the airplane – an idea of an airplane, then the information does not depend on its bearers. Before any material object, there exists an idea of a pot, the universe and an airplane. You can not imagine the emergence of an airplane, a pot or the universe before the idea. The same thing happened with the creation of my books. I have already written – **FIRST OF ALL THERE WAS AN IDEA**. An idea is structured information. It is like the alphabet, from which words and sentences are made, and with them the material embodiment of these or other images is built. Information is the building material. The idea is a certain drawing of the object. The idea with the book existed even before N. Levashov's gone. True, I did not quite determine the final theme and was not ready for the current development of events, considering that Nicolai "would cope with". But when it happened what happened – the idea of the book got a completely different sense and was voiced right after his passing away and then supported by my colleagues. I

decided to write about what I knew myself and what I could apply on the basis of these Knowledge (obtained from the works of **Russian Scientists – N. Levashov, A. Khatybov, N. Morozov** and others) in real life. This is information that made it possible to implement what today (and it does not require any proofs) is available, which you can read about and what you can be sure of. The conclusion I make, and which, I hope, the readers will agree with: Information precedes any existence, while not being anything of the existing. This directly applies to the **Technologies "SvetL"**, information about which is the basis of all that you have already known from the previous books and go on knowing more.

I am grateful to all of those who took an active part in writing previous books and I am sure that this activity of people will be continued. Or rather, I do not even doubt about it.

These books, already read, and even along with the works of N. Levashov and A. Khatybov, have already split the world into two parts. **The one which will win will be the one that is right.** As in the previous books, I will not limit myself to theoretical reasoning. I will reveal to you practical experience in the application of the **"SvetL" Programs** and I will tell you what has not been told yet.

Having an opportunity to disseminate the information presented in the books, by more, as I thought, popular means – through animation or videos, such as those created over the years relating the **"SvetL" Programs**, people's health improvement and development in cognition, I nevertheless settled on books . I am sure that **N. Levashov** would certainly support my choice. Reflecting on this, I proceed from the fact that **THERE ARE A LOT OF WAYS TO CONVEY INFORMATION** to people, being responsible for it (which is not unimportant). Children get to know it through mother's or grandmother's "cooing", toys and animated films. Now people assimilate what they are "given" – through variety shows, movies, the media, TV and, of course, the Internet, as the fastest and nearly always distorted transmission of information. But I really want my readers to learn **TO TAKE INFORMATION IN A LOGIC FORMAT**. The inability of most people to perceive information logically does not mean that they are stupid. They just have a "receiver" that is tuned in to other, "no logical" waves. Everyone picks up his wave. In someone else's – nothing but noise you will hear. So, it is necessary to "repair" and retune the "receiver", and this is best done in the Bath or at least in the Dressing Room.



As for understanding eternal truths, people are equal. But not everyone is able to formalize one's knowledge in a logical form. However, this does not belittle the knowledge itself. If I can not express my knowledge in Chinese, this does not mean that I have no knowledge. The same here. If I can not express my knowledge in a logical format, it does not mean that I do not have this knowledge. There are some for whom philosophical texts, Levashov's reasoning or Khatybov's calculations are incomprehensible; for others, folk songs are incomprehensible. For example, the song "Shine, shine, My Star", which N. Levashov liked to sing, has zero information from the point of view of formal logic. But it in no way means that it does not carry information. Certainly, it carries! The same can be said about the pictures of Levashov. They do carry a lot of information! The indicator of the presence or absence of information is action. If information does not trigger off an action, it means it just did not get you. (Look attentively once again at the pictures of Levashov...) If you know that your apartment is being flooded by the neighbor from above, which somehow has his pipes broken, certain actions should follow. If there are no actions, then the information has not reached.

These years, after Nicolai's gone, I came to an interesting conclusion. People are pretty much **READY TO GET BASIC KNOWLEDGE**. But it turns out that, in the absolute sense, logic is the least effective. It accounts for the fact why disputes that are becoming more and more active and hot, especially when they take place on the Internet, and even under the "nicknames", lead to nothing, but bitterness of both sides. The most important thing is always illogical. **People get going by things that do not need logical proof.** Today, as can be seen with an unaided eye, all the most important events in Man's life take place despite logic. Anyone can see it for oneself, remembering important events of one's life from birth to death (try to reflect on this). But, nevertheless, the emphasis in my books I made, first of all, on the logical, i.e. not the most effective way of presenting a

thought today – exactly the way in our time we decided with Nicolai Levashov concerning the information conveying to people. I'll try to explain why I have taken this path and follow it.

First of all, I proceeded from the premise that at the first stage my task (and then the task of people who became my Companions) was to convey not only my information, but also the information that was left to us by all those Humans who I mentioned in the previous books, and, in particular, information from Nicolai Levashov, as a forerunner in knowledge, to as many people as possible. To do this, it needs to be transformed into the "appropriate format" – videos, articles, explanations in accessible forms, comics, pictures and the like. Figuratively speaking, you should speak Chinese with a Chinese, French – with a Frenchman, Russian – with a Russian, etc. Who can do this? Only "translators or interpreters", i.e. those who understand my plan and idea. But today people are most emotional. They try to "understand everything with their hearts". And you can not understand with your heart what I intend, You can only feel with your heart, especially things related to the practical application of the **Programs**. Only with your head (or rather your Brain) you can understand i.e. logically. Consequently, today, when there are colossal changes in almost everything, and especially in the life support system of Man (and this term is suitable for all changes, from weather to the so-called science and politics), there is need in people who are **ABLE TO MASTER INFORMATION THROUGH THE TEXT IN A LOGICAL FORMAT**. In future, out of these people there will stand out those who will translate information into an illogical format.

As I mentioned earlier, according to Einstein, "...if you can not explain your idea to a five-year-old child, then you do not really understand it yourself". To explain something difficult in a simple way it is not enough to feel the truth. ***It should be also understood. The purpose of this book is to find people who can understand the idea that I put into it***, and then find a way to implement it and act according to the knowledge gained. With me, my colleagues or autonomously – this is another question.

When I am criticized for such reasoning, ***I react painfully not to criticism, but to stupidity***. It's more correct to say that this makes me annoyed. After all, you have to read what you are trying to criticize, try to comprehend it, and then make conclusions, and in line with the way your "receiver" is tuned in.

There are such people, and this also should be reckoned with, who are performing some things from the field of psychiatry. I do not want to let

myself go to diagnose. What a cow can do on the highway, it is considered indecent for an adult. If Man does such things, then something is wrong with him. Man can only be engaged in real things. But each one has its own reality. For one the really is in growing cucumbers, for the other – in conquering countries. To each his own. It is impossible to change this order of things. Never can a man be engaged in someone else's business. Everyone is occupied with "his own" business. I mean – the business that was imposed upon him (determined for him) for one or another reason, related directly to the ongoing processes. Especially today, when such transformations are taking place, and people are involved in them. However, Man is able to make himself either very wretched or very strong – the amount of internal energy spent in both cases will be the same. Everything depends only on one's desire and aspiration. And if Man used the **"SvetL" Programs** because of his knowledge, believe me (and I have already proved it in previous books), he would combat difficulties not when they are at the door, but long before it. ***Man would think not of what he did well, but of what else he could have done, but he has not done, and – what accounts – why he has not done?***

Nowadays everyone makes choice of what to be occupied with regardless of the presence or lack of intellectual, administrative and financial resources. A knowledgeable professor, a powerful official or a billionaire oligarch can consider their great resource as an opportunity to realize only small projects (to build a country house, for example). A poorly educated and meager with little resource man can strive to do things of great importance. Whether it turns out to be a success or not – is another question. The magnitude of human deeds depends not on the available resource, but on the scale of the Man. I mean, so far, the intention and hidden potential that can and should be uncovered. One way to do this is to make friends with the **"SvetL" Programs** and register for the Bath, not forgetting the "Broom". And the way to the "Bath" should be paved with a large-large "Spade".

To my great regret, modern consciousness of people up to the limit is filled with a certain set of beliefs, myths and directions, and has turned Man into a device that voices other people's thoughts. People, who did not ponder over the question for five minutes, nevertheless always have a banal answer to it. In the end, they have some illusion of understanding. Pseudo-understanding forms around the consciousness armor of such thickness that no logic can break it. How to find thinking people? And how can reading people give themselves at least some kind of self-esteem? It is necessary to put questions before readers, which, in fact, you have already understood, if

you read my previous books, not trying to give them any "color" or appreciation. Who has the ability to think independently will it think up. Who is not able, will remain in captivity of banality. Trying to pull out of their banality all the "digitized" is deliberately doomed to failure.

With thorough consideration, the thinking of a modern man is a rather limited and very stable system – it is extremely difficult to change it without an inner desire for changes in the Man himself. It's simpler, most likely, first somehow to initiate this aspiration, and then move to changes. This can be done, for example, through relations. We habitually believe that man is a social being, so he needs relations. Or maybe, it is the other way round, Man is a social being, because interacting and communicating with people he becomes dependent on such communication? Man strives to correlate his own judgments with the thoughts of other people – this is some kind of "accelerated" path of alleged development. And, to a large extent, it is formation of one's own position (one's "self") in society in relation to others. As a result, a certain (determined) flexible social construction is formed out of the human community, based on judgments, which, in the end, are far from reality. In the minds of different people, they are correlated with each other, and eventually, undergoing some changes and adjustments to the average standard, more or less plausible, they create for themselves the illusion of stability and reliability, not having any link to reality. In this form, **SUCH A CONSTRUCTION IS EASILY CONTROLLED FROM THE OUTSIDE**, and its composite human elements are completely satisfied with the imaginary stability of the situation and the viability of the entire structure as a whole – without worrying about the expediency of its existence as such. This expediency can not be appreciated if one's judgments are related to the judgments of other people, and not to the reality in which it exists. ***Of course, other people are also a part of this reality, but only a part...*** Thus, Man, as an element of such a social construction, can not actually correlate his own judgments with anything, there is no standard of truth if he compares his inventions with someone else's. And if, in addition, these inventions are put into words – then this occupation does not make sense at all. To accurately convey one's thoughts in words to anyone, you have to be more than genius. And if the words are not pronounced, but written – even more so. ***However, most people do not care about who and what judgments have on this or that subject;*** another view is also true – sometimes there is someone's strong necessity to voice these inventions on any occasion. Such different manifestations relate to the functioning of the same social structure, built on internal relations without

regard for external ones. The desire to share someone's own judgments in most cases – just a demonstration of one's self and consolidating one's current position or taking up a new one. ***The need to be heard often covers the need for someone's appreciation***, which is necessary only in conditions of existence in this artificial social construction. ***A reasonable Man does not need someone's appreciation at all*** – after all, one way or another, it will be perceived in line with the existing way of thinking and current beliefs. But there is some sense in it, though – through relations people can change the way of each other's thinking a little, extend it. But also can make it narrower. ***"Who keeps company with the wolf, will learn to howl"***. In the end, it turns out that the need for development inherent in man is realized only through relations and exchange of opinions. But this option can not be the only one. It creates a sense of movement in terms of cognition and intellectual activity – just because it is so much easier to control the entire social construction. If the attention of each of its elements is turned inward the society, its individual components – it is enough to structure the society of people competently, and development (or degradation) will occur in a strictly prescribed manner. The need of people for communication and society which exist now, the existing "style" of communication, its intensity and traditions is the construction imposed upon for the most effective control and achievement of certain tasks. Any changes in social construction are initiated from outside, but are taken for some kind of independent development. It would have been much simpler and painless if out of people's society being used for certain tasks it had been necessary to build a similar structure but used for other tasks. But if the existing construction is not suitable for these tasks – the same technique can be fully used to initiate the destruction of the entire structure. Removing from Man's way of thinking the closure inside the structure, that is, its elements, and transferring it to the outside – into reality, which can be an objective criterion for judgments, it is possible to initiate the development of each man, and, therefore, the construction of such Mankind which will be able to realize the true goal, and not imposed by someone from aside.

That's what I thought before I began to go carefully into the sense of generation and creation of the **"SvetL" Programs**. The Programs in the complex of interaction with the Brain, in most cases (it was shown by practice) do not quickly, but surely break these banalities, regardless of the User's age.



But the intention of Man is very important here. Intentions of one are great, another's are small. Indicator of Man's value is his intentions. Man is measured not by the quality of shoes, but by the quality of his intentions. And intentions are always determined by the Knowledge gained. A man with a lot of knowledge among people with a philistine scale of thinking feels like an adult in the sandbox. In the eyes children there is a dumb question: "...Guy, what are you here for?.."

People always act based not on the knowledge of reality, but according to the scale of their thinking. The scale of Man in this context is determined not by the dimensions of his body or by the number of years lived, but by the scale of thinking and the world perception – in fact, this is what this book is going to be about. To comprehend this, try to imagine your feelings about this or that occasion. For example, what will you feel if your apartment is looted? And what will you feel if your country is plundered? And if, moreover, you know these robbers, both by name and by sight? For one – it is a knife in the heart, when his goods are looted, for another – when his country is plundered.

However, I want to note that people who began to pay attention to what is happening not to them, but to their Country and what is happening in the Country – are growing in number. This is an objective current process that is taking place before our eyes, and why exactly this way – I have already told you in my previous books. By this I just want to emphasize that ***all my books are interrelated and written exactly as N. Levashov taught me.***

How to determine on what scale you feel, think and act? On the scale of you personality? – Your Family? – Your relatives? – Your Country? –

Mankind? The answer to this question is the indicator of your scale. If all your aspirations are reduced to buying new "toys", this is what you are looking for money for, and then in fact you are a child in a sandbox. All children aspire to "make a cake". Some have made them, others dream of making, but in both cases their aspirations are not higher than cakes. With age, children's sandbox changes into an adult one. Sandbox cakes are replaced with mansions and "Rolls-Royces". The quality of "cakes" has changed, but the **SENSE REMAINS THE SAME – A SAND BOX**. I just want to note that sandboxes begin to "close down" rapidly, "children" are crying because of the taken away scoops and ruined cakes. But this is the process of transforming all of us and everything around us. There are many, even the majority, who tend to take care of themselves only. If they have a degree, a 100 million wealth and age of 50, but think only about themselves, in fact, they are children. If Man thinks not only about himself, but at least about his family, he is closer to be an adult. If – about his relatives, too he is almost a grown up person. But nevertheless this "adulthood" does not reach the scale necessary for solving the current situation. To solve the situation, there is need for people who are able to say: "my Country", "my Family..." All homeless children are our children. We are worried about them, as much as about our own children. We feel like taking them all together, feeding them and warming them up. All these unhappy old people are our grandparents. All men and women, most of all worried about their small misfortunes, are our brothers and sisters, our uncles and aunts. That's what Russian people are supposed to be in full meaning of the word Russian. I hope very much that after reading my books, Levashov's works, and if there is some will (I'm sure-there will be), the works of A. Khatybov, A. Luchin, N. Morozov and others, about whom I have already told you, there will come out thinking and ready to **ACT IN CONFORMITY WITH THEIR KNOWLEDGE** people. The *Technologies and Programs "SvetL"* will support in this not that easy matter.

Man is able to act only within the limits of his understanding. With conventional thinking, it will not be possible to operate with large-scale categories. Moral qualities do not matter here. ***Honest and dishonest people will start up destructive processes equally quickly*** if the scale of their thought is small. The saddest thing is that **THEY WILL NOT EVEN REALIZE THIS**. ***Their honest efforts will lead to a sad end as guaranteed, as dishonest ones.*** I got convinced of this in my life experience and observed it among people who "surrounded" Nicolai Levashov.

In the era of developed communications, when every home has Internet and TV, the popularity of many people, including those who do not get out of social networks, saturating them, as they believe, with "stunning information", excludes freedom of action. The information age makes everyone famous (in quotes, and without) a hostage to the situation. Who becomes popular is no longer able to create a situation. Now he can only be built into it. The situation is created by those who sit at the "chessboard" as a player, and are not placed on it as a figure. All those personalities of an individual or a group plan who were really, and not in legends, involved as true performers in preparing and implementing current or future events, **COULD NEVER BE PUBLIC**. In no way should they be confused with representatives of any special services, circles, Masonic lodges, parties, etc. They should not be looked for and be made literary heroes and images on them. Moreover, and this is important to understand, it was extremely tough and rigorous that everything should always be controlled by the System. All this once again confirms the fact that it is very difficult to decide who is the truly attracted performer, who is the performer from the "historical scenery", and who is the initiated historical upstart or career figure. It is quite natural that around this process there were always a lot of swindlers, "historical" buffoons and bearers of some "false-truth".

It had been so. Now – everything is different. And those who think that they continue to "steer the chess game" are very deeply mistaken, because there is no longer need for such decorations; and performances with greater acting skills can be performed in any academic theater with substantially less expenses. Therefore, popular figures and those who believe that they are "playing" them do not have their own long-term or any other strategy. In reality, these are pawns in very big processes that are taking place today. But they are not able to understand it. Not gifted. Everything happens on the "auto-motor-like-way" of the past. This is the automatism in their thinking, decision-making, understanding the ongoing events and their actions. No matter how deplorable it could be, but we all have to go through this and we are passing it now.

Our Brain acts most effectively when it does not have a dissonance between the developing, the advanced and the updated, more primitive. If such a dissonance is present, then this refers to "selfish inclinations" – when man's characteristics are perceived through an incorrect paradigm of individuality instead of a scientific view of what we are – an instant, ever-changing image of a single whole that does not have a center. But even this is not the case for everyone. There is an opinion that we need history, a

chronological view of our life, in order to form our moral values. But our present understanding of the Brain nature, or rather, absolute misunderstanding, shows that a purely scientific view without reference to individuality and "history" gives a much more accurate, constructive and ethical system of concepts than our uncoordinated values. This is logical, because our usual tendency to define ourselves as an imaginary individual constant pushes the brain toward "everyday" disorders – such as obsessive stereotypes and the need to pin the hopes. Are the **"SvetL" Programs** able to help in solving such problems? Yes, they are. – I say more than confidently, because there is enough experience in their application. The Programs in cooperation with the Brain create a completely new "tool" of interrelation with the Control System, which is described in detail in the previous books, and contribute to ("teach" and help) the Brain training to see the situation in and around it. The psychological consequence of this "system" (tool) is **SELF-CONSCIOUSNESS WITHOUT REFERENCE TO THE IMAGINARY "SELF"**, which brings to the increased clarity of mind, self-control, what is often called "to be here and now", and above all, to the ability to "switch on" the Mind, distancing themselves from the emotions that are prevailing in most people now, and to be more precise, they are simply off scale. Examples of this in everyday life are more than enough. You all know them very well. "That's the end! The world is collapsing! Ruble fell down – Euro jumps up, sausage becomes more expensive, there will be nothing to live on, I'm going to the exchanger "to buy the currency on what is left..." And few people realize that this is just a small part of the implementation of the program plan to transform the Life Support System of Man. This is the beginning of getting rid of the "financial fascism" that has been built for the last almost two thousand years. Can anyone change this? No! And even those who imagined themselves to be "the rulers"? And where is the way out? Every man has his own way out. And believe me – **EVERYONE WILL FIND IT ON HIS OWN**, no matter what it is said by anyone. Only man himself by his actions is able to change something in all this. But only with actions – reasonable, not emotional. For the majority, the above is the scale lying beyond the bounds. Very few understand this subject, but they can hardly voice it to its depth and in an intelligible way, in addition, because of fear of encountering a total misunderstanding, mockery and questions like: what do you need it for? In my opinion, it is a strange question, possible only in a sick society. Why do you need to take care of the weak? Why save the child? Why do you help everyone? What is the benefit? How are you going to make money on this?

As a result of such state of opinion, negative processes are not controlled by anyone. They go their own way, people live their own way, and the matters meanwhile, in their understanding, are getting worse and worse. In their understanding, and not in reality, I am emphasizing it.

To get a complete picture of what is taking place, for example, in Russia, we have to relate them to the processes on the Planet. In order to comprehend the situation on the Planet, one must go out into the realm of metaphysics and relate it to the surrounding reality. Those who take the proposed scale for excessive one, are unlikely to be interested in further reading, but I am more than sure – those who "mastered" previous books, began to learn the works of N. Levashov and at least a little by A. Khatybov – they will master it too.

Before our eyes, the old structure of the world is dying; a new one is being born. Again questions are raised to which, it seemed, once and for all, the answers were found. What is good? What is evil? Where is barbarism? Where is civilization? Today the life of each man depends on the accuracy of these answers. I think that the worst will be for those for whom others will answer. Even latently, many people are aware of the existence of big problems. Science, industry, agriculture, the army and education are "collapsing". Morality and education are falling. Mortality, prostitution, drug addiction are growing. Where is the beginning of these processes? Those who are now thinking on this subject, have the feeling of impending disaster, or even – a war. It seems that in general terms everyone understands everything. But no one can do anything. Today, there is not even an idea – in what way the enemy, which is already known in people's understanding, will act. Will the enemy conquer us? It will. – And what's next? .. This misunderstanding of what is happening is against Russia. If during the offensive of Hitler troops the population knew what was expecting them, today they are just absolutely ignorant – people are disoriented. They are taught that if Russia "submits" and begins to behave "in the right way", it will be accepted into the world community, and normal life will begin. Comments on this subject obscure the situation more than clarify it. But most people are soothed by such an "explanation". Having calmed down, they go on to play their toys. People do not understand the point of the processes under way. The destruction of the country is taken for a natural course of events by the majority. Nobody wants to assess the situation by results. Everyone sees it according to the media reports, which persistently impose the opinion that we are "**all right**". If people could make a comparative analysis, they would see that when we were bombed with real bombs, Russia incurred

INCOMPARABLY LOW LOSSES IN LIVING FORCE AND ECONOMICS. Today, in the so-called "peacetime", we are losing more than during the Great Patriotic War. And these losses are increasing in an avalanche. But the population instead of soldiers in the enemy uniform and falling bombs from the sky sees neon advertising, exciting serials and glossy magazines, fumbles on social networks in the Internet garbage heap, searching for and spreading rumors and unverified information, and even while clarifying the relationship make use of absolutely unacceptable forms of human communication. Under such conditions, people can not properly assess the situation. Why? Because ***the unconscious is stronger than the conscious.*** Complex information is always presented in a "cool" and interesting format. People absorb it and make it their guide, and especially today, when information "pours" as stormy rivers. What kind of information – true or false – it does not matter for mastering it, because the Brain has not yet learned how to analyze it adequately. When children are laid in the subconscious the most harmful theory of evolution, the platform of atheism, it is done not through retelling boring scientific theories, but through interesting and exciting stories and films about dinosaurs that lived millions of years ago. The indirect formation of an evolutionary worldview brings to the obvious formation of atheistic thinking. I note that the direct bearers of this information, for example, teachers, scientists, etc., ***do not understand the true meaning of their actions.*** As for the subject raised here, all these scientists are the same children who are in an adult body. They are forced to do what they are paid for. Should they have the opportunity, they would gladly give up work and take up more interesting occupation. Everyone dreams of his "sandbox", for which he lives. Children-scientists with intelligent adult's air tell pupils about evolution and anthropoid apes – call them their ancestors and even **DO NOT REALIZE, WHAT THEY SAY.** They just say, **believing the hypothesis of Darwin.** None of them bothered to think about it. It is noteworthy that Darwin himself, speaking of his theory, until the end of his life claimed that ***the first link of the evolution is chained to God's Throne.***

If scientists are in such a situation, what to say about singers, journalists, directors, artists and other such figures? They have no chance at all to realize their involvement in the formation of consciousness. If you say to a group of half-naked girls (singing, but rather – making obscene gestures on the stage), and also to their producers and directors, that they propagate a certain worldview, all these guys will be surprised, because they are sure that they do not do anything like that. They "just" sing and dance, "just"

write, "just" entertain or earn money. ***But as a result of all these "just" the Man is being formed.*** What kind of personality he (she) will be depends on what kind of toys he (she) played in his (her) childhood. ***What*** kind of cartoons – watched? ***What*** kind of songs (he) she was listening at the concerts and taught at school. That's the dilemma I encountered in the process of writing my books and articles. The idea of this book, on the one hand, is very simple – to provide the necessary knowledge that could at least somehow orient people in the current situation and continue the story about the technologies that could help in this. But, on the other hand, being perfectly aware of the shortcomings of the impersonal general education system well-known to all of us today, I would like to achieve something more. To give help, first of all, young people and, of course, the elder generation, which believes that the life experience gained by them is unshakable; to understand the inconsistency of the process of knowledge today and the whole tragedy of the "development" of science in all fields, and especially in matters of people's health, and through this make them comprehend not only the laws of natural science, but also their present place in this complex world and the processes that follow. And, of course, I'm going to continue the story about the Technologies that both can help and really solve many life problems.

In my books there is not everything, but much of the heritage left to us by outstanding Russian scientists N. Levashov, A. Khatybov, N. Morozov, A. Luchin, and many others whose works I have known and got some information from, even "without their permission", for one reason or another (I do not think that someone will be offended with me after realizing why it was done), "the" information which I found necessary and which I comprehended and passed on to the readers ***so that it eventually could turn into the readers of this book, knowledge.*** Such an approach in realizing the intended is inevitable when the task is to orient people in the infinite ocean of knowledge.

The words ***of the great ancient Roman physician and thinker Claudius Galen*** come to my mind, who in his introduction to the treatise "**On Natural Abilities**" wrote: "And when he reaches maturity, he will be overcome with a burning love of truth. Like an obsessive one, neither day nor night can he stop pushing himself and straining to study in perfection all that

has been said by the wise. Having studied all this, he will continue to test and check for a long time whether this is true knowledge, as they say, or all this contradicts the obvious facts. Following this way he will choose one for himself, and the rest will reject. It is for such a Man, I hope, my treatise will prove to be useful. However, until now such people have seldom come across me. For the rest, it will be something of a beautiful narration told to asses" **(III, 10)**.



With asses, Galen, of course, went too far, but, in general, among my readers I really want to see the type mentioned by him, projecting it not only for today's youth. These readers (I mean the young) are extremely dear today, because in the future they will certainly make up the cream

of Russian science, and I'm sure – not only science. But, experience shows, my work is **NOT GOING TO BE EFFECTIVE FOR EVERYONE**. There are other readers – with aspirations opposite to those mentioned by Galen. And this is objective. The problems of science and knowledge do not interest them, and they do not like what I'm writing about. I do understand it, and therefore, I have no illusions about the power of my logic, which has already been stated and is going to be stated. Like Nicolai Levashov, I take it easy that the majority will have a negative attitude to the written and suggested by me, even if they find my judgments to be flawless. It is the same like in an aphorism of the type – "you're right, but I still do not agree." People conscientiously forget logic and return to their democratic beliefs (science, the notion of their health, religion, socialism, fascism, communism, etc.). It should be realized that human nature is manifested here, which has been broken and mutilated the last almost two thousand years. Bearing in mind both, I found in the book by the same Galen that N. Levashov in his time gave me to read ("**On the purpose of the human body parts**"), and through which I first knew about this Man the following: " No one is more unpleasant to me than a listener who does not follow my words... And like ministers when making secret speeches tell the uninitiated to plug their ears, so I am now, initiating my listeners not just to human statements, but to the most true sacraments, tell the uninitiated to plug their ears. Asses will sooner perceive the art of playing the lyre (that is, the justice said here) than these people. I know that, in general, few will are able to closely follow the course of my reasoning, but for their sake I do not hesitate to say my secret thoughts to a crowd of unworthy people. **After all, the book can not by itself**

judge and choose those who would like to get to know it; it will not ignore the ignorant and will not give itself into the hands of worthy people... Our God, who is well versed in the ingratitude of such people, nevertheless brought them into the world... No good person is jealous of anything; ***he is created to help everyone and improve everything***. So we, knowing perfectly well that this book will be slandered and mud will be slung at it a thousand times by people who are unreasonable and ill-bred (like a poor orphan, who fell into the hands of drunkards), tried to write it for the sake of those few who were able to listen to it with benefit for themselves and judge all that we say" (**Book XII, Chapter VI, 20-22**).

I would say similar words about my books, and about the books of N. Levashov, A. Khatybov and many others, which serve as a reliable and inexhaustible source of new knowledge today. Someone else's knowledge, other people's information from books, works and other sources of information must first turn into the flow of your consciousness, perhaps even in the form of a strong emotional experience. You should not be scared with it, it is the opportunity to gain personal experience and your knowledge. An educated person is someone who knows **WHERE TO FIND WHAT HE DOES NOT KNOW**. When N. Levashov created his Generator, he realized it well. I also understood this when I started to work on the **"SvetL" Programs**, their transformation and creation. I did understand how much it would make life easier for the people who knew and believed in the **Programs** on the basis of their knowledge and their experience, in such a complex and extraordinary current **Time, which we did not choose. The time has chosen us with all the following consequences**, which I told about in the previous books and go on the story in this book.

* * *

Chapter 1. Comment to yet not told

– Is it true that you negate such authorities as Hippocrates, Galen, Newton, Einstein, Fermi and many others?

– No, I do not negate the authorities of long-dead scientists; I negate the long-dead dogmas.

Time has come to jump into the time in order to jump over time! We do not choose the time we live in – time makes its choice. People who kill time will not notice when the moment comes and time kills them. It is not time that changes us, but we leave it behind or waste it on the wrong things and at the wrong time. We gradually begin to understand that our moral foundations, our spiritual world, more so, our way of life, no longer agree with the conditions of life which the society is plunging into – and our understanding of the events under way is not enough to overcome the emerging difficulties of its possible development. Biologically, and consequently, psychologically, we remain the same "hunters for mammoths", as our Neolithic ancestors were. Mankind has entered a global storm – the Age of Change.

Irrespective of the already known to us purposeful formation of what is conventionally called humanity, it is absolutely clear that everything that is happening on the Earth, the whole formed structure of human society with its level and construction of consciousness, biosupporting and existing needs is an extremely inharmonious formation. Any actions performed by Man or a society of people, founded on some information basis, reflect the level of the society's (Man's) world understanding. It is obvious that if Man with his deliberate actions, and the advanced technologies created by him, has come to what can be observed today, if we look at the whole picture – our world view has been formed somewhat erroneous. So, regardless of why it was formed that way, it is necessary to relearn to get and analyze information in order to form a closer to reality, and, therefore, more correct worldview.

Interacting with each other within the framework of the social structure, people stubbornly and invariably orient themselves towards certain social standards and principles. This is applicable to any group of people united by some criterion (achieving a common goal – a labor collective, scientific laboratory, parents of students of the same grade,

students of this grade, a staff of the city hospital, etc.). One person can be an element of several, and sometimes many, of such groups, so there are plenty of examples of their functioning. Absolutely inevitable an individual position sooner or later, (depending on the Brain construction) comes into conflict with the official "group", or systemic positions. Making one's own decision within the framework of systemic orders or according to one's understanding is a key moment. With such moments, or rather, with people who are able to make their own decisions, society is formed and the direction of its development is determined. While omitting the question of why and in what way Man develops his own conviction, his view of the ongoing events and the ability to follow his own views and convictions with all responsibility and understanding of the consequences, let us draw our attention to the main. The central point is one particular Man with his way of thinking – neither the society, nor the system or the state, on which it is accepted to dump all the blame and problems.

Now, keeping in mind all that we have touched on in the previous books, let's recollect that all the known historical events were properly directed and provided with the heroes-performers – people who, at certain times, existing within the framework of some society, social construction, demonstrated the possibilities and reality of the above. On the condition of being loyal to the task they performed. For all that, no one convinced them of the correctness of the chosen path or their faithfulness. It is not known for certain, but I think that those comrades were devoured with doubts and uncertainties at times. However, the execution of the task was always carried out rigorously, in good time and always with the use of an "advanced" group of performers.

Now we being guided by this information, having analyzed it and compared it with those facts in the origin of which we have no doubt, we understand that a return, or rather a thorough correction of mankind's development, distorted by outside interference, will be made by a similar way (in our today's understanding) but at a different level and consciously (for the last reason you have the chance to read this book now). Although, probably, it would be easier and faster "in the old way" to impose the appropriate Brain genotypes upon the fulfillment of the calculated tasks – and after 5-6 generations to get already more or less cleared of debris, the restored planet, suitable for cultivating on it some other Humanity, since the existing one will represent only a group of very convenient and effective biorobots. Why it is going to be this way – I will try to explain in this chapter, touching on a number of historical moments and the reasons for their

formation to solve specific problems. For those who are going to the Bath, it will undoubtedly be useful and informative for the general understanding of the ongoing events, considering that it (**the Bath**) is exactly contributing to the development of those Brain functions, which will give the ability to acquire knowledge with the non-aggressive nature of its possible use. And in a simple way – in **the Bath** the existing Brain will be given a chance, and the Broom will provide some acceleration – a boost to development, so that from the biomaterial grown by the Interventionist ECS, there will be recreated a true Man, capable of not only removing the vtrash", but also finding a harmonious state of his Mind with the Minds of higher orders. This is the principal purpose of **the Bath**.

The foregoing puts forward the corresponding additional requirements for the observance of certain new, but obligatory, principles for constructing such an Organized Being structure that have already been adopted in Civilizations of a higher order. The beginning of judgments about them and the formulation of concepts and definitions of such new principles can not be delayed in time, since not only the completion of research in this direction, but the very fact of understanding their true essence, inculcating them into the base of the emerging new social consciousness, and not only those, who managed to get to the Bath, also require certain time. **BUT WE ARE ALL SHORT OF TIME.**

1.1. Attitude to history

I will not take the responsibility of predicting the image of the world and Humanity even in the coming decades, but I am deeply convinced that it will be much easier for people to make the transition to a new state if they prove to be sufficiently armed not only with certain knowledge, but also with their own ideological paradigm, not being content with someone's, "cooked up" with unknown purposes. Man will need a spirit, an orientation toward a new value structure that is as different from the modern one, as the structure of the values of the Greek polis inhabitants was different from the views of Australopithecines emerging from the rainforest into an inhospitable and dangerous savannah.

Recently, many people have been talking about "the time of troubles in Russia", and such a phrase is not only fully justified, but also perceived by the society as a natural expression of reality. But are we thinking that it is

time to talk about the "time of troubles" that has enveloped the whole planetary community, if, of course, we take this invented term to explain the ongoing. After all, the way out of any time of troubles requires the statement of some clarity, some common goal and a common understanding that permeates the minds of all the people inhabiting the Planet. Such an understanding in the past, as the history of mankind shows, came most often (if at all) as a result of human passions, or more precisely, of the specific people's "passions" (or groups of people) to achieve what they thought were their desired goals that were almost always accompanied by seas of blood and an immense number of destroyed human lives that were not involved in these "passions" at all. We know many examples of this: the result of religious wars in Europe, costing two-thirds of the population of Germany, the Napoleonic Wars (1799-1815 – 6 million people), the Dungan uprising in China (1862 – 12 million people), the First World War (1914-1918 – 15 million people), the civil war in Russia (1917-1923 – 9 million people), the Second World War (1939-1945 – more than 40 million people) and many other examples that inform us in terms of the number of people killed. But, might there be another way? In any case, such a question has already been put, and people are obliged to try to solve it – to solve on the basis of their new knowledge and a new worldview being formed on the basis of this knowledge. **THERE IS NO OTHER WAY AND CAN NOT BE ANY LONGER** – this is my personal conviction. And for its comprehension, philosophical systems and "pictures of the world" of the past, considered and comprehended by people not at all within the framework of that hisTor(ah)y, which we have been fed up since childhood, may become necessary.

In this book I will provide you with some historical facts known to a few, but these facts, found and purified from weeds by very worthy, in my opinion, prospectors, do not answer the main question – why was it exactly the way it is told? In what connection, and what is common in all these historical moments and why did they bring humanity exactly to the results we are seeing and reaping today? And without this understanding, the movement forward, with an eye on what happened (even really true) – has no prospects. But, carefully studying history, if, of course, **THERE IS A DESIRE TO INVESTIGATE** those processes that took place in the past, first of all, we have to proceed from the fact that the controlled processes of the old Program are completed. This means that everything that has been happening since 2012 is people's «getting accustomed» to the implementation of such Programs, the format of which is completely new. Moreover, for many of them it is incompatible with the previously set

programmed purpose of the old system. The coercive nature of the launched process can not become creative for everyone. But this is also a way to give a boost to people's own development – people's attempts to comprehend the ongoing is the natural state of their Brain's work. The changing surrounding reality makes them strain in their attempts to perceive the logical links between the facts of reality; and it is this desire to recognize themselves as an active part of what is happening, rather than its passive element, that may serve as a tool for their own development. Although many people perceive the events taking place, unfortunately, in the auto-motor-like way, exactly in the second way, as it had been organized by the old system.

PEOPLE ARE VERY DIFFERENT, LIKE THOSE CIVILIZATIONS that came into being on the planet. Any attempt of unification of civilizations, spiritual aspirations, and just desires would be not only utopian but tragic. And at the same time, humanity is one unit. But this unity was formed every time only to achieve specific goals within the framework of the old Control System. Nowadays, there is an objective need for many people, with all the diversity and direction of desires, aspirations, and actions that are necessary (for their development), to have some common component with all this. This component can and **MUST** be given by **NEW KNOWLEDGE, NEW TECHNOLOGIES**, which I mentioned in the previous books, and that system of thinking that will grow on their basis, and which can be called rationalism. But not the rationalism of the 18th – 19th centuries, but the rationalism of the modern, grown at the brink of the new millennium, based on the achievements of people who, as they thought in their time, were creating a "new science".

We have just experienced an era when it was believed that there had to be ***the only one and, moreover, the "right" worldview***. In fact, each Man has his own one, and we can talk only about some of its general universals. ***The very notion of "the right worldview" seems to me nonsense and it should be excluded from the scientific, and everyday vocabulary***. At the same time, it is very important to realize that the process of forming a worldview is extremely complex, it is being formed under the influence of many factors – this includes family, customs, communication with people, reading books, and contact with art ... And, of course, – that real practical everyday life, in which each Man lives. Such a process of the worldview formation **CAN NOT DEVELOP BY ANY ORDER**. A special and tremendous role is played and assistance given in this today by the technologies left to us by outstanding ***Russian scientists N. Levashov, A. Khatybov, A. Luchin and others who are safe and***

sound. All these technologies, which have proven their prospects, are **VERY IMPORTANT** for Man in the current the so-called "transition period". But the analysis of their role in human cognition from a purely worldly or "scientific" point of view in the process of the worldview formation is far from being simple. We should not forget what has been done to us and how we "have walked" for several thousand years to what we are observing and having today; in what way and what kind of the world view we have been imposed upon which belongs to the majority of people today. And here the word "technology" in the context of their application in the development of knowledge, the manifestation of interest in the current events, the comprehension of the ongoing and Man's making his own decisions on the emerging problems, is incorrect, to put it mildly. This is a whole complex of interactions with the Brain on the basis of its physics (nature) of activity. And in this process aimed at the Brain development, of course, the knowledge of how and what was done to us (and more precisely what was done to our Brain and why) is, in my opinion, very expedient. But only in the context of what **THAT HAD ALREADY BEEN AND WILL NEVER HAPPEN AGAIN**



* * *

How did all this start and how was it lined up? **First of all**, these were traditions, myths, fairy-tales and signs that for many tens of thousands of years formed the basis of the human worldview that far-away time, when this world view remained quite universal, without disintegrating into individual and group ones. The process of creating the planned Brain genotypes began.

People lived following the rigid canons dictated to them. And even now traditions, myths and signs, as some hidden element of clan structure and implicit control, still play a significant role in our life.-for example, in the process of family up-bringing, when conveying the information support, directed primarily (but in auto-motor-like way) to a certain development of specific Brain genotypes. Their influence can not be ignored. I would call this source of worldview an esoteric idea – the idea of reliance on the accumulated "ancient knowledge". But if we still want to get away from esotericism and all that is related to it, we should answer the question – **"...where did this ancient knowledge originate from and who possessed it initially"**. This ancient knowledge is always within the framework of the tasks and the processes to be accomplished, which are regulated by the Control System. In most cases, they **HAD A DECISIVE ROLE** in shaping the world outlook, and therefore, in the guided and controlled story of each Man. **The second source** that shapes the worldview is religion. Or, rather, the idea of God. This idea came into being at a much later stage in the formation of mankind, and we will return to this more than once, because the very concept of religion as an element of the system to control people is evident to many people today.

At the heart of my approach and reasoning, as well as the used material (information from the works) of those who have been repeatedly mentioned in the previous books and those whose works (information from works) I considered highly expedient to use when explaining the current situation, lies the principle of "empirical generalization», which was formalized in his time by V. Vernadsky (to him, however, there are a lot of questions). Its point is in the fact that as the starting point for any analysis of everything that occurs in inert matter, living matter or society, there must be statements, in line with (non-contradictory) empirical data, i.e. our experience – the experience gained in our practical activities. Adherence to this principle makes it possible to increase the likelihood of realizing the expected development of events, but, of course, does not guarantee that the conclusions obtained on the basis of such empirical generalizations will have absolute certainty. Empirical generalization is also just an interpretation¹,

¹ So, the empirical generalization is always some interpretation of reality, and it is ambiguous: different empirical generalizations may correspond to the same set of empirical data. One and the same colors can draw quite differently the same landscape. And no final experience can not eliminate the ambiguity of interpretations. The development of intelligence and new knowledge, too, can not be a guarantee of unambiguity, for new knowledge reveals new problems that exclude the possibility of a closed system of axioms! A person always makes decisions under conditions of risk and uncertainty, which can not be eliminated.

however, in order to understand the material proposed in this book (at the level of today's Brain development of the majority of people) its use is advisable.

Relying on the works of people I respect: **A. Yuriev, A. Fomenko, G. Nosovsky, D. Andreev, A. Tyunyaeva, G. Panteleyev, V. Efimov, V. Chudinov, A. Yakovlev, S. Sall, Yu. Shutilin, N. Moiseev, A. Nikonovich, Yu. Ocheretyanny** and other scientists in the broadest sense of this word, I created a kind of virtual "information library" as an operational tool for presenting my plans. Each of them today, due to their capabilities, is trying to convey information to people (sometimes shocking by its seeming "improbability", especially, in the view of modern science), and I will try, with its examples, to show readers why the described by these researchers and taking place in the historical plan events (and these events are interpreted, to put it mildly, outside the framework of what was given to us as hisTor(ah)y for supposedly our cognition) occurred exactly in such a sequence and at such times. For this opportunity, I am really grateful to all of the above, and especially – to **Yuryev Alexander Ivanovich**², who I met in the autumn of 1991, and who did a lot for my knowledge, taught me a lot in matters of psychology, political psychology and Human capital. This term "Human Capital", which later got the widest development, and not only in Russia,- was initiated and substantiated by him. The same Man took direct part in the foundation of **the Russian Scientific and Technical Society (RNTO)**.

1.2. Upwards out of darkness

Unfortunately (however, as you already know, it is objective), most people react to someone's attempts to find answers to questions of being with some feeling of annoyance – they say, "...why are you set on it? Live like everyone else!" Those few who have broken through the indifference of others with their inventions and research are doomed to exist in a narrow circle of people, and their "accessibility" is greatly reduced by various things, from secrecy, restrictions in contacts, limitation in their works accessibility up to closing the information they knew. It was hardly possible to talk heart

² **Alexander Ivanovich Yuryev** – Russian psychologist, professor, Doctor of Psychology, Head of the Department of Political Psychology at St. Petersburg State University, author of numerous works, member of Russian and foreign organizations <http://www.yuriev.spb.ru/about/yuriev>

to heart with such a scientist, especially when he was of some value for humanity. However, even if this happened, the conversation was doomed to fading. At best, a lengthy and near-problem interview was available. And today, when it seems that all the obstacles in the dissemination of information are "taken off", it is very difficult to understand the thinking person, and this process requires preparation, as well as a certain level of knowledge. This is clearly evident from the responses and questions that arise in relation to the stated in the books by **N. Levashov, A. Khatybov, and others**, and I get a great number of those. As today's practice shows, the most accessible form of communication, making it possible to think it over and understand what has been said by such people, – **IT IS A BOOK**. In it, you can return to an incomprehensible place and independently find the answer to author's statements. However, **SUCH A PROCESS REQUIRES LABOR**, too. People, in the majority, are not very receptive even to this variant of knowledge. The most simple and usual – to the "Internet search engine" – and the answer is ready. And why should one comprehend this ready answer? It was probably answered (written) by someone "smart and knowledgeable". On my own articles and works, I often have to read reviews in which the readers refer to certain authorities, as a scientific interpretation, which is beyond doubt. For the most part, these interpretations are accepted as dogma and are defined only "as a word from modern science" or even a word from God himself. For all that, the reviewers completely forget that the Bible, for example, was created by people, and if it contains the word of God, it is only in the retelling of the listener. Quite recently, one of my "reviewers" said that ordinary people should not question the words of world known scientists, since there are authorities in science (like in any other field or sphere) who know more than we do. I was not at all surprised by such illogical categoricalness. This was what the forces of the so-called "world elite" aimed at: ***the lack of logic in thinking and belief in the imposed dogma are the priority of slavery. Such an approach***, first of all, is **THE LACK** of even **AN ATTEMPT TO SEE** the world with one's own eyes and use the information received for analysis. To feel happy they are satisfied with the frame-intellectual potential, imposed from the outside. When talking to such people, I have a feeling that their endless questions about the meaning of being so natural that, starting with the dilemma of the origin of an egg, and not touching a small part of the aspects of this problem they turn to UFOs. Fragmentary knowledge of these people does not follow one from the other, but go in an arbitrary order as familiar words appear in conversation – a phenomenon similar to Pavlov's

reflexes. ***In such cases, one always has to understand that the difference between a scientist and an intelligent person is that a scientist knows a lot, but an intelligent one not only knows a lot, but also understands something about it.*** It's nice to be a walking encyclopedia, but it's twice as nice to be able to analyze. Man who possesses such abilities will never fall for the trick of rogues of any rank, which unfortunately, are still more than enough in our world.

*In the Academy of Sciences
Prince Doondook is sitting.
They say Doondook
Does not deserve this honor;
Why is he sitting, then?
Because there is something to sit on.*

This, as you may have guessed, from **A.S. Pushkin** about authority... However, it is enough about this. There is something more interesting than this and similar rubbish, which remains in the past and has no prospects for the future.

The success of physics and, above all, the discovery of the greatest of the sciences "created by mankind" – the science of the microworld, quantum mechanics – played a decisive role in the formation of a new rationalistic worldview, within the framework of development of the Brain genotypes according to the predetermined programs. Thanks to these discoveries, Man is no longer an outside observer: it turned out that he could see the world "from inside". True, he, the man, still has not understood why it has happened so.

This vision gradually spread to other areas of knowledge, including the comprehension of historic processes in the past, to which we are going to return. And we'll carry on our talk in this book, starting with physics. We approach the subject, starting with the translation of the word "physics" – "Nature". So it will be more comprehensive for our understanding, and more objective. But with all this, here we encounter one non-trivial difficulty. The last three hundred years, almost every decade, and since the middle of the 19th century – somewhat faster, new facts "were delivered", immersing people who "moved" science, into new depths of the material world, understanding of which required more and more high professionalism. And for this, the Brain had to develop accordingly, but only the selected (not by us) genotypes, through which all the current tasks were solved, so to speak. We **WILL NOT IMMERSE** in many details, as there is plenty of

information available to everyone today. However, there arises the task of choosing a certain "initial level of knowledge", which makes it possible to draw an integral picture intelligible not only to a specialist physicist, but also to those who, having discarded the imposed delusions in attempts to understand the surrounding world, tries to understand what is happening. Or, as Nicolai Levashov put it, – ***seeks to see the whole iceberg, not just what is above the water*** ... So, having taken some facts for the initial ones, we have to ignore a lot of information and ideas that appeared in the post-war decades of the twentieth century. Changes in the technosphere, demography, the society structure and the picture of the world are taking place so swiftly that the recent fiction becomes a reality without realizing these changes by man. And the further, the more swiftly.



Look at this picture attentively. How deep and truthful it is if it is correctly interpreted. That's what Levashov was talking about. **AWARENESS OF THESE CHANGES**, and more important, their anticipation³, – today is the same guarantee of survival of Man, people, state, ***as the recent preservation of age-old traditions.*** With a full understanding of such a position,

we will rely only on those facts from modern physics (nature), on those of its positions that qualitatively change our vision of the relationship between man and the surrounding world in a movement directed toward the truth.

True science was supposed to consider the object of its research on the maximum possible historical depths of the past and prospects for the future, but today **THIS APPROACH IS BECOMING INADMISSIBLE** and does not provide answers to the emerging contradictions in the world outlook of the ongoing events. Today, natural reality is described by objective logical, mathematical, biochemical and other laws of the natural environment. The psychology of the Mind is, first of all, intended for action in it. But for the Mind to begin to "work", you have to remove your own

³ **Anticipation** in philosophy and psychology is a prediction, an idea of an object or event that occurs before the act of perception, the expectation of an event.

emotions, and oh, how difficult it is to do it today! After all, Man has to live **IN THE WORLD OF EQUIVALENTS OF THE NATURAL ENVIRONMENT**: social conventions, legal norms, economic relations, "subordinately" regulating human behavior. **Success is achieved by those who use subjective laws, but not objective ones.** Anyone who rejects all prejudices and understands – only **the Bath** can help in this.

1.3. "A particle of God" et cetera...

In the recent past, physicists, with the stupendous confidence declared the indivisibility of an electron and its one-and only initial world forming basis significance, as well as the planetary atom model and other scientific blessed firm oblivion in the code of the surrounding material nature, which allowed them, with granite certainty, to assert that they were eternal, because they were right and non-alternative!

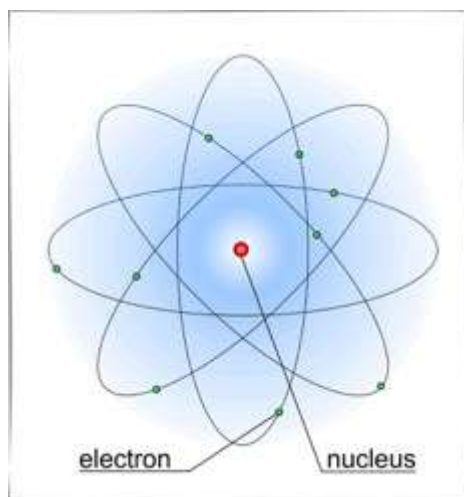

But only now, instead of recognizing this erroneous sly assertion of the recent past, hundreds of really nonexistent "elementary particles" were added to the list, whose holy list grows day by day, but with "original" names that caress the ear of only their "scientific anatomy-pathologists" ("A particle of God" et cetera).

It would be better to put something closer to your own anatomy in your names, it would be more modest, easier to overcome the "difficulties in finding examples on yourself," and somehow it would be more closer to the "reality" in the simplicity of the surrounding life perception, **ALL THE SAME INVENTED BY THEM**, but still is sensed by them at least by something (it does not matter it is not by head). The point of their judgments is not important for the future, but for themselves, let them go on inventing whatever they like, since the alphabet consists of as many as 33 letters, and the variants of the word verbiage are still quite sufficient in their possible senseless combination.

The further with our knowledge we move away towards minimizing (or equaling – maximizing) the levels of dimensional scale in the material structures of the formed surrounding reality, the less chance is left for the

past scientific granite stronghold of the imposed past simplifications regarding the **"THEORETICAL INVENTIONS" ABOUT ELEMENTARY PARTICLES**, their "real" participation in the composition of matter formation from the surrounding nature, as well as artificially invented for them dimensional parameters (supposedly quite accurately calculated by someone else) as a product of the same fictitious virtual unreality. Perhaps, sometime later generations will forgive them these fantasy pranks, but only because their descendants knew how to add something, take it away, increase it a little, and sometimes somehow divide it all, being sure that all created by them with their own fictitious laws are invariably preserved, whatever happens and whatever they would try to change destructively on their own initiative, that is, liquidate (in the sense of conquering nature). But nature's essence is far from these senseless hobbies, and it (the nature's essence) has got seek and tired of such "pranks", that's why it has to "shake up" a little the whole of the past, bring all the surrounding reality into harmony and recreate the expediency of the former habitat conditions on our planet!

Immediately we should protect ourselves in all the judgments from the ideas of the Einstein's turbid period of the magical significance of some mysterious all-powerful "cosmic dust" in any of its dimensional scales and states in the processes of matter formation as such, and wherever it has been, including its majestic "dominant filling any dimensional scale of the whole of the Universe "(according to the proponents of Einstein's judgments from those times up to this day). But out of this "magic dust", apart from the same dust, nothing else can be formed, even if for centuries it is deposited on layer by layer either in the Universe, or in the offices of the magnificent Temples of Sciences, even when with the acting all the "laws revealed by people" on gravity, movement, preservation of something in something with strict account in all that happens of all nothing explaining constants and other relativistic (formulaic) debauchery, but with **MANDATORY PARTICIPATION OF THE "SPEED OF LIGHT"** even in conditions of strictly isolated darkness! So why to protect? Because in our world, created not by us, everything is connected with certain goals or, more precisely, achievement of specific goals in the Brain development. But first of all, we are interested in how all this was realized through the actions of certain people, who we continue to consider today as geniuses of their work and founders in cognition, including ours today. I quite agree with Gennady Vladimirovich Panteleyev in his conclusions on the emergence of this turbid period. He has dug down to the very sources of history and answered the

question – ***when, how and by whom the "talent" of Einstein was created, and what was the forerunner of this.*** Falsifications in science are impossible without a certain political background and often bear the form of a state order. This state of affairs began to be practiced a long time ago – in the time of the persecution of scientists by Papism, but the flourishing of falsifications occurred in the 20th century, when the "talent" of Einstein was created by the Zionist circles for the purpose of proving the selectiveness of this people (or more precisely, the superiority of this 4xx genotype of the Brain). Papism and Zionism are phenomena of one root. And it is often difficult to understand – where Catholic Judeo-Christianity begins and Judaism ends. They were the Ashkenazi Jews who created the Vatican in its present form. Actually, these are not Jews, but the Khazars, who have fled to the West of Eurasia after being beaten by Russ. But I want to remind the readers once again that whatever it is called, whatever links have been given – all this was the development of a specific Brain genotype in the perspective of subordinating everything and everybody to themselves. Familiar names for us are quite applicable for an initial understanding of all that has happened, so we will use them.

Papism was created for the spiritual control of developing Western Christianity, for which **THE WORLD WAS PRESENTED THE BOOK, NAMED THE BIBLE, or THE SYMBIOSIS OF TORAH – THE OLD TESTAMENT**, and the real **SPIRITUAL BOOK OF THE GOSPEL**. For all that, the latter was compressed to a minimum by consigning the greater part of the original Holy Scripture to oblivion. I have already mentioned that if you approach this from a mathematical point of view, the Old Testament takes up more than 83% of the Bible, leaving everything else to the New Testament texts. So what is the main thing in this "document"? What the reader sees is just a small part of the heritage of Christ and his disciples. The Gospel is much larger, and the reader probably heard about ***the Gospel of Judas, the Gospel of Mary Magdalene and others***, information about them from time to time, but seeps through the sieve of church censorship. The appearance of the Bible in Russ is related to coming to power of Germans – Romanovs of Russia – the Lutherans, who **ORGANIZED NIKONIAN REFORMS** – and the World could see renewed Catholic Orthodoxy with the Bible in hands. However, this was not always the case – before the Romanovs restructuring during the Great Time of Troubles in Russia, there had been quite different belief. **It exists even now: it is an old belief, in which the Old Testament, called Judaizing**

Lutheranism, is completely absent. The Old Belief, by the way, recently was given a significant boost in its development.⁴

I want to note here that the primate of *the Russian Orthodox Old Believer Church, Metropolitan Cornelius* is a man who came from the common people, and he really worked **30 years out of his 70 years** at the factory as a worker. Can we imagine that Patriarch Cyril or someone from the ROC worked in his youth in the factory? We will go on talking about this on the pages of this book.



So, we go further. The Vatican is forced to adapt to the achievements of science. Unable to comprehend the Universe, the Pope led scientific censorship. The most vivid example of such an action of the *Vatican bishopric is the Nobel Committee, which is called to help science, but in deed to control it.* The scientists of the world are tied with corporate rules and ranks – they are not free in their search. Only a few have found the strength to abandon this dubious prize. The Vatican has not only controlled science, but also prepares "discoveries" by the time when the society becomes obvious of the inconsistency of certain dogmas in science. ***So it was with Galileo, Copernicus, Einstein and others.*** All of them appeared at the right time and presented what the world, according to the

⁴ May 31, 2017, in the Rogozhskaya Sloboda – a settlement where Moscow Old Believers have been living for more than two centuries, an historical event happened without exaggeration. The head of the Russian state visited the residence of **the Primate of the Russian Orthodox Old Believer Church, Cornelius**. Cornelius paid a return visit, as explained in the Kremlin: in March 2018, the metropolitan visited the residence of Vladimir Putin.

papacy, was allowed to know. And the reader already, I hope, understands that this is the controlled vector for the development of future events, directly related to the implementation of the main and global plans through the direct participation of people in them.

One of the greatest falsifications is all that is connected in our knowledge with **Isaac Newton**. Russian scientists have confidently proven that the world of science is **SPECIALLY TAKEN AWAY** from the path of truth to the slippery path of lies. Christ's "knock and the door will be opened" is deceived, and the doors, at which it is suggested to knock, turned out to be from the evil.



Isaac Newton is an English physicist, mathematician, mechanic and astronomer, one of the creators of classical physics, but one can prove without any special effort the whole inconsistency of Newton's discoveries, which lies within sight of everyone⁵. Let's look at the Moon. According to the Law, the motion of celestial bodies in orbits is due to the force of attraction between the masses of bodies and the speed of bodies relative to each other. And let's look at the Moon-Earth-Sun system and find out where the resultant of the forces of attraction from the

Earth and the Sun acting on the Moon at the moment when the Moon passes between the Earth and the Sun, that is at the time of the solar eclipse, is directed. Let's take simple calculations with you, readers, so that it is easy to control the course of reasoning.⁶

So, the gravitational force **$F=g(mM/r^2)$** :

g is the gravitational constant, equal to approximately **$6.6725 \times 10^{11} M / (kg \cdot s)$** ;

m, M – the masses of the Earth, the Moon and the Sun;

R is the distance between them;

⁵ Reflections in the future time", chapter 6, book 4.

⁶ We have already touched on this in Chapter 6 of Book 4. Let's see it more thoroughly.

the mass of the Moon is $7,3477 \cdot 10^{22}$ kg;

the mass of the sun is 1.98911030 kg;

the earth's mass is $5,9737 \cdot 10^{24}$ kg;

the distance between the Earth and the Moon is **380,000,000 m**;

the distance between the Moon and the Sun = **149,000,000,000 m**.

Substituting these data in the formula, we get: the force of attraction between the Earth and the Moon = $6,6725 \times 10^{-11} \times 7,3477 \cdot 10^{22} \times 5,9737 \cdot 10^{24} / 380000000^2 = 2,0281020H$.

The force of attraction between the Moon and the Sun = $6,6725 \times 10^{-11} \times 7,3477 \times 10^{22} \times 1,9891 \cdot 10^{30} / 149000000000^2 = 4,391020H$.

That are the first signs of falsification! The force of attraction between the Sun and the Moon is twice as high as between the Moon and the Earth, and according to Newton's law, the Moon should continue its flight around the Sun, leaving the Earth-Moon system. It turns out that the law of universal gravitation is unfair to our eternal satellite⁷. Or is it not a satellite? I will return the reader to my reasoning about the Moon in previous books. And now tell me – are you surprised? So what? Did our teachers lie to us at the physics lessons at school? They lied because they were deceived themselves.

Let us, however, return to the law of "universal" gravitation. Logically, the Moon, moving around our planet, must impact on the trajectory of the Earth. However, this does not happen, and there is no zigzag motion. Is it because the Copernican Solar System is also a fabricated legend? This is very well written in N. Levashov's book "Inhomogeneous Universe". The space is inhomogeneous and multidimensional. But all this was predicted by Lomonosov, discovered by Mendeleev, and... distorted by Einstein. Scientists have to somehow get out of this error, but they do not have enough strength, courage and audacity to shake the historical authorities. It is much easier to come up with a nonexistent neutrino, an elementary particle for explaining the mass



⁷ «Theory and practice in the description of the object to be taken to the Bath », Chapter 3, Book 2.

defect in nuclear physics. Strange is this defect, however. Completely contradicts the "genius of Einstein," the Nobel laureate and the creator of the theory of relativity.

It's time to remember an old **Laplace Pierre Simon**. He claimed that the gravitation of the Sun does not come from where we see it, but from a completely different point of the Universe, that is, there is no gravitation of the Sun at all. But according to Einstein's law, the speed of light is finite. Infinitely remote objects are long gone in the place where the light started. But gravity exists! And the speed of its spreading is, indeed, infinite, since it operates in the entire Universe at the same time! Laplace found that the speed of gravity spreads seven times faster than light, and modern calculations threw the speed of light even eleven orders farther. Well, what is to be done with the theory of Einstein and the law of conservation of energy? I remember that it is based on the fastest speed in the world – the speed of light... Again, falsification !?

1.4. Chance of a pseudo-theory

There are many who revere Newton as the great scientist. His laws kept humanity in ignorance for many centuries and led civilization development along a dead-end road, the road to nowhere, and therefore false. Later, let us dwell on what actually "discovered" Isaac in the right time for the Vatican, but there was also "activity" outside of science. Few people know that in the 18th century England went from a comparatively backward and poor country whose economy was also undermined by revolutions, wars and turmoil, to a mighty power that had the most advanced and fastest growing industry in the world. The mystery of this "economic miracle" has long agitated many



people, including historians. But if earlier the main reason of the British industrial revolution was seen in technology – inventions and introduction of machinery into production, recently more attention is paid to the analysis of the financial system created in England that time. It was the creation of this amazingly flexible and reliable system, that enabled English banks to

operate for many decades with means, the volume of which **GREATLY EXCEEDED THE REAL POSSIBILITIES** of the national economy and, thereby, provide domestic entrepreneurs with significant loans at very moderate rates. In turn, it is this generous lending of production that made possible its radical modernization, including the massive introduction of expensive steam engines. But how, in fact, did England succeed in creating this mechanism for financing the economy and then for a long time supporting its uninterrupted work? In answering this question, in my opinion, the analysis of the event that has become a kind of prologue to the English "financial revolution" – *the monetary reform of 1695–97*, in which the population was seized and replaced free of charge by new all the spoiled and fake silver coins.

Isaac Newton (1643-1727), appointed in 1696 Warden, took active part in preparing and implementing this reform, which was called **the Great Reminting**. In 1699, he was appointed Master of the Royal Mint. Newton occupied the post of Master permanently until 1725, and for all that for his enormous services to the state, before 1705, was elevated to knighthood by Queen Anne. Leaving for rest, he secured the appointment of John Conduit (1688-1737) – Newton's niece K. Barton's husband – who by that time had served as Deputy Director for several years. Thus, the continuity of management was ensured, and we can rightly speak of the almost 40-year-"Newton era" in the leadership of one of the most important financial institutions in England.

ALL THIS HAPPENED IN THE PROGRAM FRAMEWORK, which were unfolded in 1433 with bringing into quite active functional state the Alps Control Complex 1, with the participation of which a new 441 Brain genotype was introduced. The whole process was unfolded up to 1841. This was the next stage of its functional development, embodying all the stages of development of energy biogenesis of the "shirt" of all generations and the level of the functional and contact-informational ability of the Brain to get information from the System. Introduced new mantissa, in combination with previously mastered, significantly increased the ability of the Brain of individuals in the very process of **COGNITION AND COMPREHENSION** of the information **PROVIDED** by the System. It was a kind of "brain leap". The level of intellect, as a certain constructive perfection, has grown and began to possess a greater ability for the practical implementation of the acquired knowledge in technologies, actions and events, as a program control process for the part of the System. The biostructures *on the territory of France, Spain, Portugal, Italy,*

Western Europe and England were subjected to this active process. The server-based process control center was Rome. That's where the rationale for all the acts to which the Vatican and the Pope are involved. This period of value development should be defined as **the "Sacred Rule of the Selected."** And after it there "hastened" the period from 1841 to 1990.

At "Easter" of **1841 the Alps 2 Control Complex** introduced **the Brain genotype 442**. This experiment mainly covered the territories of eastern and central Europe, the Baltic countries, the European part of Russia and its Trans-Urals, and later the migration of the part of the functional episodes was carried out on the territory of England, the USA, China and Japan. The central executive server of the **process implementation is Paris**. Introduction of this Brain genotype was very important for the old Control System, this stage of development completed the long period of the administrative development process – **PREPARATION OF THE "GOLD BILLION"**. We'll take a closer look at this later, and now we'll finish with Newton. About Newton's participation in the creation of Masonic lodges and his meeting with Peter I in 1697, after which a decision was made on the so-called "substitution of Peter", and about everything related to it – there is already a lot and quite detailed information, so we will dwell on the more pressing and less popular. **So, the "discoveries" of Isaac Newton!**

Here are the basic ones. He developed differential and integral calculus. He created a theory of color, laid the foundations of modern physical optics. Of considerable interest is the work of Newton, famous in the history of science, **"The Mathematical Principles of Natural Philosophy,"** in which he expounded the law of universal gravitation and the three laws of mechanics that became the basis of classical mechanics.

The story of the creation of this work, the most significant in the history of science along with the "Elements" by Euclid, refers to 1682, when the passage of Halley's Comet caused an upsurge of interest in celestial mechanics. Edmond Halley then tried to persuade Newton to publish his "general theory of motion." Newton refused. In August 1684, Halley came to Cambridge and told Newton that he and **Renn and Hooke** had discussed how to derive from the formula of the law of gravity the ellipticity of the planets' orbit, but did not know how to

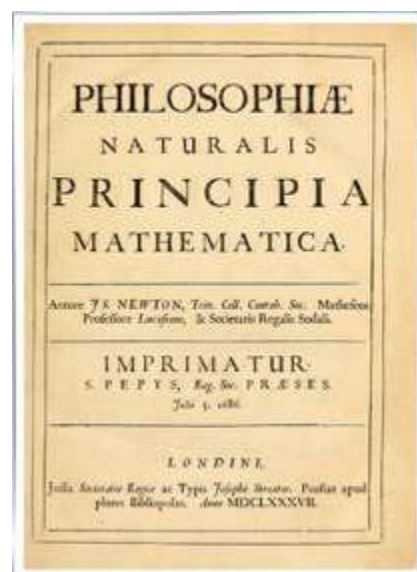

approach the solution. Newton said that he already had such solution and showed it to Halley. The latter immediately appreciated the meaning of the result and method, in November again came to see Newton and this time he managed to persuade him to publish his discoveries. And this work came out. It might seem there is nothing interesting here. And you go on reading further. **Halley, Hooke, Newton and Ren** are graduates of the same university – Cambridge University. It was they who created the myth of Stonehenge⁸ *for the passage of the Greenwich Zero Meridian through England*, which made it possible to create the **ONLY ENGLISH CHAMBER of MEASURES AND STANDARDS**. Now it brings fabulous profits to England, which sells metrology services around the world. Those who are familiar with production know the cost of these services in metrology and standardization. And now imagine how many streams flow into one pocket from the whole planet. They invented the ancient pyramids and legends about the monoliths, of which these buildings were made in the **13th-16th** centuries AD. According to the same **TECHNOLOGY OF GEOPOLYMER CONCRETE** and plaster, Stonehenge was made. *I note that the whole of Petersburg is practically one large exhibition of the application of high-quality geopolymer concrete.*



"Ancient" observatory deserved respect, and therefore other contenders turned out in outsiders. All these people come from the poor layers of the population: pharmacists, traders, brokers, etc. But all of them are students-"saizers" who did not pay for education in Cambridge. According to the norms of that time, the "saizer" was obliged to pay for the studies by various works at the University, either by providing services to

⁸ Covered with mysteries and legends, **Stonehenge is an ancient megalith located in the south of England, in the Salisbury area, 130 km from London**. This is a complex of 30 roughly rustled huge pillars and stone slabs, placed on each other in concentric circles. The purpose of Stonehenge is still not fully understood by scientists: some consider it a temple, others – an astronomical observatory, some – a tomb and legends say that here the rites were performed by Atlanteans, Hyperboreans and the famous wizard Merlin.

richer students, or was paid by someone who the authorities tried not to advertise. According to official history, there are very few documentary evidences and memories of this period of Newton's life. It is not true. All of them, including Isaac, are scholars of the Vatican, and the payment was made by **the Catholic Order of the Cisterians**, the one that created falsifications in the history of the world and revealed to all of us that mythology that many still take for the truth. **The Order of Bernardine-Cistercians is the main papal support in the matter of falsifying world knowledge.** All these scientists, in fact, are agents of the Vatican, which paid off with them not only money, but also honor, fame, and most important, work in science without fear of being burnt at the stake. The Anglican Church will take a dominant position in England later. **The times of Isaac's life are the times of Catholicism domination over the world of Europe.**



The experience of Britain was summed up and taken into account. Although the imperial might of England by the end of the 19th century was beginning to decline, a new Island, the civilization of the United States, a worthy successor to the "second Venice", takes its place. America in the 20th century takes advantage of the rich arsenal of secret wars, intrigues, financial international machinations and many other things inherited from the British. I hope the reader will figure out the rest independently.

I hasten to inform you that the Pope does not give up his positions, revealing new and new discoveries to the world in a profitable aspect. Look at your computer. It was created at the very beginning of the 19th century, 8 years before Napoleon's campaign against Moscow and 12 years before the photography creation. Although it is believed that the first computer appeared in the 20th century, but already in 19th the first prototypes of modern numerical control machines were built.

Joseph Marie Jacquard, the French inventor, in 1804 came up with a way to program the work of the loom. The invention of



Jacquard is a very ingenious mechanism: by the variety and infallibility of its action, it can be equated with the movements of a perfectly trained animal. To get a patterned fabric, it is not enough to lower all even or all odd warp threads alternately in order to pass a shuttle with a weft thread into the resulting "yawn". It is necessary to omit only some of them, in a certain order – different for all threads of the weft that make up the given pattern. Each warp thread passes in a weaving mill through a special knitting ring, knitted at Jacquard with a special vertical shaft. All of them are arranged quite closely, in rows, and at their upper ends a piece of cardboard presses with a pattern of holes corresponding to the rods that should remain at rest. The number of such cardboards necessary for the pattern is connected to a continuous chain, and a simple mechanism shifts them automatically after each passage of the shuttle. The principle of the Jacquard machine is used in many apparatuses, for example, a varistophone, a mechanical tapeter, one of the Wheatstone telegraphs, and the like. However, **THEY DID NOT GIVE LIFE TO THIS INVENTION**, and for a long 200 years the meeting of humanity with the computer was postponed. *And Newton, who wrote a philosophical work, cast people back for a longer time – almost 400 years, giving the world a chance for Einstein's falsehood.*

1.5. Absence in the presence

Let us return to the formation of mankind. A society was formed, consisting of followers and leaders. It came into motion, because some people followed others, and today they are following them. In order to understand why, what for and what directs the masses movement, it is necessary to understand what directs those who lead the masses, and what they are. Since people always focus on what they consider to be the highest value, the led mass is moving towards the highest value of the leaders, though, almost never understanding these higher values. The question arises: what are these leaders and what are their supreme values? In order to answer it, you have to understand what Man is in general, why he acts in certain situations in this way, and not otherwise, who and **WHAT IS THE REGULATOR OF THIS**. And, as promised, we will look for answers in the past, but we will transform the information within the framework of not that history, we were taught at school, but we consider the real processes of the past, taking into account what you have already known from the previous books and that new information about the past, which is strenuously making

its way today to the knowledge of people. At an intelligible level of today's understanding, but considering the desire of many people to take the Bath or at least to get to the dressing room, we move on.

* * *

At the beginning of the 19th century, the world appeared to people as some unusual complexity, but still a mechanism that was once "started up by someone and still operates", and which eternally functions according to predetermined, rather knowable and quite certain laws. The last statement is especially important – if we do not understand anything today, then later we shall understand without fail!



Such was the belief in the unlimitedness of rational knowledge, based on the incredible successes of science, which, alas, we have to give up today. And what about Man? ***But there was just no Man in this scheme.*** He was only **AN OBSERVER, INCAPABLE OF INFLUENCING** the eternal, once and for all definite course of events, but capable of responding to events, establishing links between phenomena, that is, to learn the laws governing the mechanism, and, thanks to this ability, to anticipate certain events. And no more than that! The man was only a detached observer of the ongoing events around him and visible by him format. Through the prism of the rationalism ideas, he was simply "pushed" to the periphery of the planned processes, which he could not in the least influence. And rationalism, was given rise to exactly by this. Despite the emergence of scientific knowledge, only a humble role of the observer was assigned to man. The urge to get deep understanding of the processes taking place in the world was suppressed, and knowledge was severely limited and regulated within

the framework of programs for the creation of specific Brain genotypes and their subgenotypes. And, what is important is the fact that within the framework of rationalism, however strange it might be, the idea of the "Absolute Truth" arose, about what there was "in fact" – that did not depend on the observer. – And on God, I would add! But this belief in the existence of the "Absolute Truth" allowed Francis Bacon⁹ (or more precisely, through his Brain) to formulate his famous thesis on the conquest of Nature: ***knowledge – "absolute knowledge" is necessary to Man in order to make the forces of Nature at man's service.*** Man is unable to change the laws of Nature, but he is able to force Nature to serve humanity. Against this background, the so-called science, – **SCIENTIFIC KNOWLEDGE, GOT AN OBJECTIVE – to multiply the human forces.** From that moment, the place of science in society has become quite different. A new anthropocentrism arises: Nature is thought to be an inexhaustible reservoir; it is intended to serve man, his whims, satisfaction of his unlimitedly growing needs. There arises a new paradigm, following which occurs exactly as it is necessary for the development of specific Brain genotypes. It is extremely important for us to note one main point: ***only in the Christian world did this utilitarian perception of science arise.*** Of course, the results of observations and studies of natural phenomena were used by the Chinese, Arabs, Babylonians, and all other peoples, but only in the Christian tradition did the perception of science as a creative force arise, as a powerful weapon in the hands of man. Science that period, which is nearly goes on in an auto-motor-like way now, was no longer the way to satisfy only one's own curiosity or a mine of information for the chosen and initiated, as it had been in Ancient Egypt or medieval monasteries – it became a means of conquering Nature, a source of new human activity. This system of views was called classical rationalism, and its visual results utterly changed the social status of science, but, again, these changes occurred through specific people, to be exact, through specific Brain genotypes, making followers and leaders in science. Of course, the idea of Man and his place in the world changed, too. A new form of the human brain evolution in the context of specific Brain genotypes opened a mine of knowledge, but, as we see now, and the Pandora's box at the same time. This

⁹ Francis Bacon (Francis Bacon, January 22, 1561 – April 9, 1626) – English philosopher, historian, politician, founder of empiricism and English materialism. One of the first major philosophers of the New time, Bacon was a supporter of the scientific approach and developed a new, antischolastic method of scientific knowledge. He contrasted the dogmatic deduction of the scholars with an inductive method based on rational analysis.

is in our emotional perception of all that was happening that time. And to consider all this within the framework of achieving the ultimate goal that was set by the Old Control System, then it was absolutely objectively done to turn people into creatures that, in principle, could not have high goals. People were turned into a mass, a crowd, a herd. In such an atmosphere, people were becoming just amoeba with two thoughts: where to get money and how to spend it. The people, turned into a crowd, submitted to vice, demanding only bread and show.

Against this background, the pyramid of the control was finally built up, which found its reflection in the sign that appeared among Egyptian priests, which then passed with its original meaning, then put into it – to the masons. Jews called it the "Star of David" to conceal the true meaning of this sign.



Later, the same Masons out of this sign "created" a sign called the "all-seeing eye", which we see today in virtually all the Kremlin halls, and mainly, in all the buildings of the churches that belong to today's ROC (Russian Orthodox Church), and if to be more precise, – the Russian Orthodox Greek-Catholic Church. This requires decoding.



Orthodoxy is not Pravoslavie. "Ortho" is right (pravo), **"doxia"** is faith, that is, **ORTHODOXY IS RIGHT BELIEF, BUT NOT THE RIGHT TO GLORIFY GODS** (pravoslavie). However, since the time of Nikon and his reforms, Orthodoxy is translated **as Pravoslavie, they say, this is the church tradition.**

The Greco-Catholic, or Ecumenical Greek Church, is Greek Catholic, because the letter FETA is read differently in Eastern and Western Christianity: both as **F**, and as **T**. Few people pay attention to this, and this is one of the signs of those who are ruled.



Let's continue with the symbol. What is the main meaning of this sign (symbol)? Everything, **AS ALWAYS, IS IN THE SIMPLICITY**. A triangle with a vertex up is a hierarchy of those who rule in this pyramid. The lower crossbar are all those that are controlled, the so-called people. The second triangle, turned upside down, is Knowledge! The maximum – to those who are above, and the minimum expressed by the inverted vertex of the triangle, is to the people. Any sign (symbol) conceals a concept in itself; the invested meaning. To understand the meaning hidden in this sign (symbol), you have to compare your personal conceptual base (the system of concepts) with the base of the one who created this sign, with its author. He, the author, through this symbol conveys to us the world of his concepts (a personal model of understanding what is invested by him in this sign). A measure of understanding a sign is the scale of the human concepts system. If we do not compare our measure of understanding with the measure of the author's understanding, which, in fact, was given to a few, then there is a simple memorization of the sign meaning imposed on us by those who, at their discretion, gave information about this symbol (memorizing words) without realizing the meaning that bears this sign. But for the initiated – this is a completely different understanding of the sign meaning, in accordance with the place of its presence.

People live by patterns. There are many for who they mean more than common sense and logic. For more than two thousand years, people have been knocked into their heads since childhood, that adherence to patterns is inherent in human nature, that people are driven by subconscious directions and beliefs. They subordinate and determine our whole life today. You can,

using logic, convince Man, and he will become your like-minded person, but only **AS LONG AS HE REMEMBERS THE SYSTEM OF DEMONSTRATION**. When your new "like-minded" forgets the logical chain of demonstration, *he will return to his old beliefs*. The more complex the demonstration base, the faster it is forgotten. Meeting this "like-minded" in three days, you will be surprised to find that you've wasted your time proving something to him. The current life has washed away from his consciousness everything you have shown him, like formulas on the seashore – a wave washed them away, and everything again became virgin clean.

Man has natural desires, given from birth, and he has developed ones. For example, both now, and a hundred years ago, a man reacts to female charms in a similar way. But music of a hundred years ago will cause other emotions, rather than the modern one. It seems to Man that this is because he likes this music, and he himself makes his choice. In fact, it is a "formed taste", imposed from the outside. Well, who forms the tastes; he determines the direction of social energy flows. That's the way the old Control System worked.

I do not agree that in order for conscious directions to grow into unconscious, **GENERATIONS OR UPHEAVALS ARE REQUIRED**. Either Time or Upheavals give rise to Beliefs. Previously, old directions were broken with the situations associated with danger to life, war, famine and natural disasters. Now they can be broken by means of certain technologies, such as the **Technologies "SvetL" with their Programs**. It is very difficult today, even when we all live within the framework of the New Native Control System, to break old directions – by logic, through cognition, through experience, to convince anyone in the new and inevitable. But, in my opinion, it is necessary to go only this way, which has a great variety in achieving the goal. This, in fact, I try to do with my articles and books, explaining what I have known myself.

1.6. Controlling circumstances

Who "rules" the current events today, choosing the road to the future? There are many who ask themselves and others this question. Some are sure that the Zionists. Others believe that they are Masons, pointing to abundant Masonic symbols, including in our country. Still others – the "Committee of



300" or the Bilderberg Club¹⁰. There is no question – The – the Jewish community has a great influence on all aspects of modern life, both in our country and, for example, in the USA. However, it is also true that the US, like the USSR, is the state that was created in line with the old Control System in the framework of solving specific problems; and at the source of the North American statehood there were Masonic lodges, which originally began their development, as we already know, in England with I. Newton's active participation.

Freemasonry (441 Brain genotype) came into being as a union of energetic people who did not fit into the traditional society with the king, aristocrats and the power of the church, and therefore decided to destroy it. One of the first "Masonic" Orders was called ***the Sepulchryers Order***, which in translation means "Order of the Guardian of the Sepulcher". Whose Sepulcher? Not the Order of the Guardian of the Holy Sepulcher, but the Order of the Guardian of the Sepulcher. And from this Order of the Guardian of the Sepulcher, two other Orders detached: the Order of the Templiers, and the second Order, which was all forgotten,

– ***the Order of the Priory of Zion***. For all that, the Order of the Priory of Zion had in its emblem the Golden Griffin – a golden lion with wings of an eagle, standing on its hind paws. Their motto was remarkable: ***"The king of birds is Eagle. The king of animals is Leo. And we will rule people with the help of gold!"*** The modest guys were they from the Priory of Zion.



And now anyone can go to Varvarka street, to the so-called House of Romanovs and look at the coat of arms that they have on the wall. It is a griffin standing on its hind paws with a sword in its forepaws – the Order of the Priory of Zion. And next to it was the diplomatic mission of England, as we are told today, or the English Court. This is just – a lyrical deviation.

¹⁰ **The Bilderberg club, the Bilderberg group, the Bilderberg conference** is an informal annual conference of about **130 participants**, most of whom are influential people in politics, business and banking, as well as heads of leading Western media. Log in to the conference is possible only by personal invitation



Positive tasks for "free masons" were the creation of a market, the introduction of democracy and the establishment of personal freedom. Private ownership in the market conditions gave birth to the bourgeois system. Democracy assumed transition to a republican form of government with a separation of powers. Personal freedom expected separation of the church from

the state and moving on to legal methods for regulating conflicts and life. The former basis and the governing methodology on the basis of religious denominations, including methodologies based on spiritual values, introduced through individuals of **423 Brain genotype**, by that time had lost their **GOVERNING AUTHORITATIVE ACTUALITY**. This was the decisive reason for leaving the stagnant state of slavery for feudalism and from it – for the initial formation of the capitalist platform as a more perfect system of management and social arrangement of that time. However, behind the creative tasks there were three negative ones: destruction of the absolutist monarchy state, the Catholic Church and the traditional, mainly non-market economy. So you can, of course, reason within the framework of development of historical events, which were perceived by people and interpreted by those who described the happening. Masons served as the "cement", "mortar" for cementing the "bricks" of industrial capitalism, its basic elements. Three hundred years ago, these parts already existed without any freemasonry – and manufactory (the embryo of the factory), and financial capital, and parliamentary system, and the rudiments of free press, and the courts of urban craft corporations, of which the independent judiciary of the modern West have grown. Freemasonry **DID NOT GIVE BIRTH TO THEM BUT USED** them, penetrating these structures and filling them with their meaning. Masons set the matrix of the industrial-democratic civilization of the 20th century with its classic indications: separation of powers, liberalism, private enterprise, freedom of religion, general elections, etc. Penetrating into already prepared structures (like viruses in a cell), Masons rebuilt them from inside for their matrix. All structures were subject to recoding: political, spiritual and religious, financial and economic, information, industry, and education. All of them served as bricks for erecting the building of a new civilization of capitalism, and it is not for nothing that "mason" is translated as bricklayer, a builder of

the Temple, the Industrial Civilization building. All this is true, and much is written about it, both true and untrue, but, stumbling, the true information gradually finds its ever greater embodiment, striving for the truth. The main and the only true cause of all this "historical mystery" is **the introduction of the Brain genotype 441**.

The consequences of the Freemasons historical activities did not end there. Speaking for democracy and equality, Freemasonry itself had **RATHER NON-DEMOCRATIC STRUCTURE** with a hierarchy, with strict division into the higher (selected), middle and lower. Masons were divided in degrees of initiation. This was justified by the fact that **the Program requirement to govern** in the ruling class itself was rather pronouncedly divided into the need to govern publicly – for the executive level of people, and the need to govern through hidden influence, i.e. not publicly – for the governing level of those through whom the governing was carried out. Why did such a programmed division occur among the ruling class? Because the ruling class of the executive level presented **only genotype 441, which had a different, higher Brain level. Only they were predetermined, along with knowledge information, to get the information of the control associating and initiating them to make decisions** on the organization of subsequent executive activities, which also included determining the ways and forms of people's being. **In connection with the possession of more advanced functions of the Brain, the knowledge of the governing character gained by them was carefully concealed from all other people**, i.e. some isolated sacredness of the state of the governing actions was manifested. For this, only the governing class of the executive level organized among themselves various kinds of secret orders and other hidden structures or societies. The introduction and implementation of the decisions taken by the mentals¹¹ was passed by them as a governing function to the lower class and was implemented through the governing class of the executive level of people who presented partly the Brain genotype **441** and basically the Brain genotype **42**.

The market, for which the Freemasons advocated, was originally based on finance. Its true product was not classical capitalism, but a monetary system in which financial capital dominated all sides, spheres and factors of economic life. With the introduction of **the Brain genotype 441**, the

¹¹ **Mentals** are executors of the Control System programs.

program significance of the governing influence of the "power of money" has changed in the direction of strengthening its contribution and increasing its role. It was during this period of gaining control functions by individuals of the Brain genotype **441** that the balance of the shaken power of authority on the basis of the outdated religious methodology was withheld at the expense of the "power of money". The society got a boost in the development of banking. This made it possible to begin activating the process of the ***formation an organized financial system and bringing it into a state of the complete control by the Brain genotype 441 with the involvement of specialists of other genotypes***, while discarding all previous material authorities.

The control, possession and use of the substitute¹² were completely taken by representatives of the Brain **genotype 441**. All subjective values and their basis changed under the dictatorial influence of sacred orders and clans. This genotype, as ***the leading executor of the Conceptual Power***, in a short period of time managed to gain special control functions in society, neglecting all legal norms, and seize the right ownership and control in everything related to the organization of people's being, completing the process of giving "the power of money" as ***especially significant power function of the control process***. It was during this period and ***precisely with the Brain genotype 441 that a special state of the control functions for the executors from the Conceptual Power was born*** – the process of money revanch began, i.e., "Financial revanchism." For those doubting the best argument will be the words of the American professor Nicholas Murray Butler, quoted in the book by Ivor Benson "The Zionist Factor": ***"The world is divided into three classes of people: a very small group of people who direct the course of events; slightly larger one – which tracks the course of events; and the majority, which does not understand what is going on"***.

The state created by the "free masons", of course, stood on the separation of power, but at the same time it had a kind of a **"PILLAR" IN THE SHADOW OF THE POWER**. Masons built a secular, secularized society in which the church was separated from the power machinery. But for all that their society was thoroughly ideological. Thanks to a carefully designed matrix, Freemasonry (this ethical, social, spiritual or symbolic

¹² **Substitutes** (from Latin **substitutio** – replacement) – interchangeable goods or services.

system according to the personal values of each) quickly spread in Europe, and even faster – in North America, taking peculiar forms in each country. Being a more subtle logical structure and a higher level of the functional capacity of the Brain (thanks to the introduction of new mantissas, including) which was able to get the governing information from the System, as well as great ability for practical implementation of the acquired knowledge in technology, as the program control process on the part of the Control System, **genotype 441** with all its accepted for realization the Brain improvements, in a short time managed to change the structure of statehood and law, the social reorganization of societies on a large territory of France, Spain, Portugal, Italy, Western Europe and England (Rome is the server). The main concealed "formula" that has been developed and introduced into people's minds can be expressed as **"...life is spent on making money on it"**. It, this formula, is relevant to this day for very many people.

At the first stage, when the masons had to break down the old society, they were engaged mainly in destabilization and demonization of the world. They stood at the origins of the bourgeois revolution in France, the Restoration in England, and our revolutions of the early 20th century. We meet them at the cradle of the Garibaldi campaign for the unification of Italy and the creation of a united Germany in the era of Bismarck, among the organizers of the overthrow of Spanish rule in Latin America, the dismantling of the Ottoman Empire and the establishment of the Turkish national state. Mobilizing forces to defeat pre-capitalist society, Freemasonry gathered under its banner those energetic people who could not find their place in modern society. That is why the Masons were individuals who (for our simplified understanding), are called passionate in history. That is why their ranks in the 18-19 centuries were being reinforced so actively with Jews. They, the Jews (with a majority of **441 genotype**) had the programmed state of the "preemptive ban" – that ***they were specially selected first representatives of a certain Supreme Governing basis*** with the corresponding assigned rights: to know and to control everything and in everything, to "form" a special knowledge of the world and isolate all others from it. There were not any secret swords, boots or raincoats, or special rules, statutes, stone pedestals or oak coffins, bloody or bloodless mysteries and rituals, signs and emblems, etc. which played a role in this. ***Such a state of "preemptive ban", supported by the Control Complex***, allowed a small group of individuals of the Brain genotype **441** to gain full authoritative executive state. After all, they were alien to the Christian civilization, and the passionate charge of the Jews

reached high intensity. Here there could be found businessmen and intellectuals who had no rights in a traditional society. Here part of the noble elite was pulled up, dissatisfied with the old order. Thus a fulminate revolutionary mixture was given rise. In Masonry from the outset there were two trends. One is creative, constructive. The other based on robbery, "booty". **The first one** laid stress on man's self-improvement, self-knowledge, and the mastery of hidden knowledge. **The second one** relied on the technology of appropriating other people's wealth, creating a hierarchical world, seeking to divide the mankind into masters and slaves. These tendencies were intertwined. Trophiism allowed them to find resources, creativity – to turn them into something new, use them in the constructive activity.

Building power social structures of the society, formation of economic systems (economy) **ON THE BASIS OF THE SLAVISH APPLICATION** of the "economic man", the law that justifies and imposes violence, mandatory for all, except for the leading genotype, programmed increasing and non-solving social problems is *the way of hardening and developing the functional capabilities and abilities of the Brain genotype 441* under tough and difficult conditions, in the nascent age of machines.

This period of the value development should be defined as the *"Sacred Rule of the Selected"*. The methodology of values "People of Value" – finally passed to the antisocial basis, the process of the labor division was initiated, and in reality – the programmed implementation of the Vectors of the Goals of future phenomena, actions and events that covered almost four hundred years of the future. The main feature of this period of four hundred years long is the fact that *the program-determining governing substance of the state of the Mind has finally passed into the position of the "Digital revenge", i.e. all governing information is transferred to its own basic digital basis*. By the end of **1840**, the leading position of individuals of the Brain genotype 441 in the sphere of the societies control **HAD BECOME SHARPLY DISORIENTATED**. Conflicts within clans and secret orders became more active. The effect of actions and the legitimacy of the executors decreased significantly. However, everything connected with Freemasonry, continued in a auto-motor-like way. Industrialism finally won and became the dominant mode of the economy by the beginning of the **30-ies**. By this time, Freemasonry had fulfilled its historical mission and thereby outlived itself.

The emerging industrial society turned out to be very complex and contradictory. Its structures appeared to be specialized and differentiated, multi-branched and multileveled, having their own, not always coinciding direction of changes and their rhythm. And then in place of the old religious orders and traditional Masonic lodges (that is, closed societies) in the second half of the 20th century there comes an entirely different construction, which starts up in its embodiment in 1841 and lasts until 1990.

As you know, **during the "Easter" of 1841** the Brain **genotype 442** was introduced by **the Alps 2** Control Complex, the development stage of which completed the long period of the governing development process – the preparation of the "Golden Billion". This period was excessively saturated with the completion of the perfection of many important governing processes of the whole System, one of which is the **IMPLEMENTATION OF THE PROGRAM OF DEVELOPMENT OF THE WHOLE 44 BRAIN GENOTYPE**, namely, the formation, of basically special group of executors framed in the structure of the Golden Billion. This should be regarded as the determining goal of this short historical stage, which allowed raising the discrete controllable executive state to a higher level both in the plans for the development of the energy biogenesis of the "shirt" and in the direction of planned cleaning out and clearing of unnecessary ones, i.e. exhausted individuals, **NOT ALLOWING THEIR FURTHER APPEARANCE AND DEVELOPMENT**. The formed group was not great in number but had significant advantages in its functional purpose – concentrating on relatively small territorial definitions. And everything – the so called his**TOR(AH)**ical events, and their reflections in the descriptions, – were only **"NON-GUILTY" COVER OF THIS PROCESS**, and most likely, disorientation in understanding the events taking place. The scale of the program tasks was **planetary and time-compressed execution of up to a century and a half**. Against this background, preparations began for the creation of **genotype 461** (created in 1990: the server – California), as the foundation of the entire group 46¹³. The main task of the Control System was creation of such biostructures, the Brain of which fully corresponds to all the Program directions of the System and is completely controlled. At the same time, the realized Control of the entire being of individuals and the society social organization were to be only in the form of

¹³ For more details see materials of the SRI «The Foundations of Mankind Formation».

a pyramid (as required by the imported basic basis when creating governing information).

The "construction" was to be executed as shown in the figure below, and by 2012 the second cycle of formation was to be completed, i.e. the work on the formation of all individuals of the second group with the **Brain genotype 46**, which was the complete programmed processes of development of the target spheres of capitalist and socialist being, to transform into **a single** governed state with the corresponding social structural changes, built on **the liberal democratic** basis of all constructions of the sphere of power in the interests of **transforming the World Control in a stable state with the leading role of the "Golden Million"**.

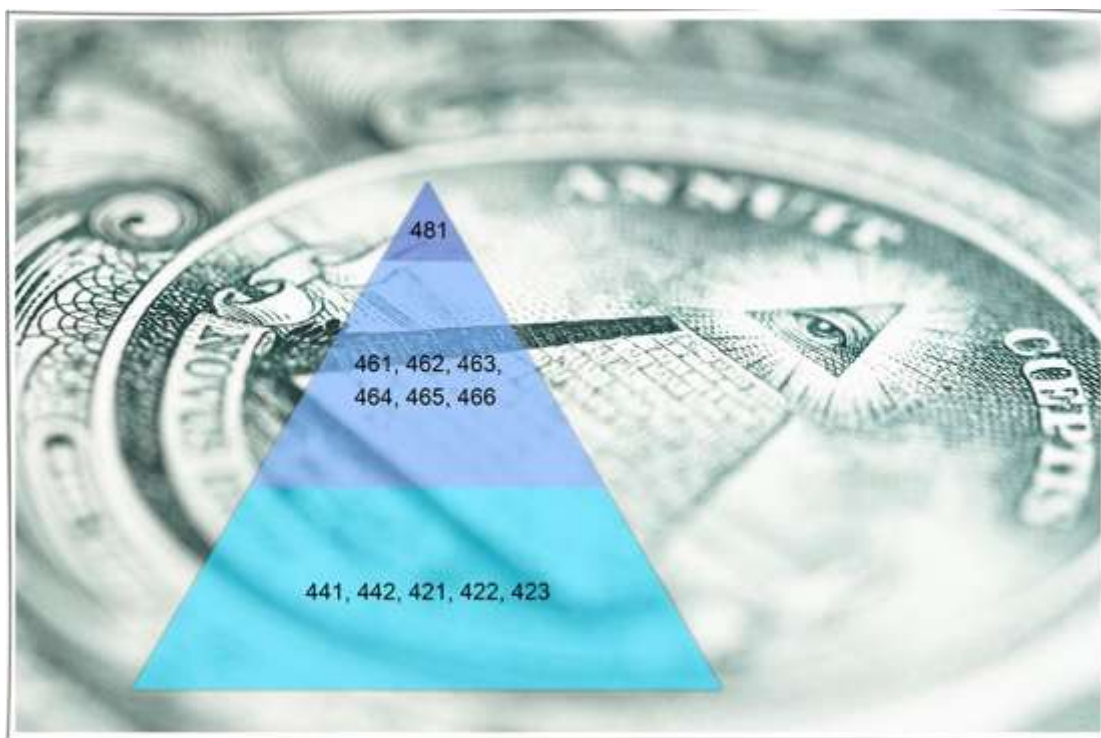

1.7. Objective subjectivity

With the introduction of the Brain genotype 442, the entire system of being Control of the world community finally passed into the phase of the irreversible rule of the **"Golden Billion"** over the rest of the world population, constructively securing all the might of its power through complex all-round violence framed in the form of a certain pyramid of power. A vivid example of this was demonstrated by the System **in the period from 1922 to 1953**, which was realized through a special governing

circumstance, which we designate "Stalinism". The governing circumstance "Stalinism" with its Vector target entrustment was intended for the "liquidation of the liquidators", i.e. ***the process of eliminating all those who were executors in the process of eliminating the previous type of civilization i.e., the Monarchy was predetermined by the program.*** And the scale and intensity of actions and events during this period is a question connected only with technological mandatory control peculiarities of this period. Add to this period all the horrors that occurred and were connected with so-called repressions, conspiracies, camps, war with its consequences, and with many other things, which, in a purely human sense, make you just shudder, getting to know more and more details of what was happening .

The reality of the program process development, from the point of view of controllability from the outside, was completely different. The leading role in this was played by the formation of various programmed control circumstances, directed in accordance with the decisions of specific program processes. This is the main substantiation, but not what was issued at the level of philosophical fabrications based on some of "historical" facts related to the observation of certain events that occurred before the eyes of people who could not objectively and truly substantiate the happening. Under way was the phase of civilization – the control ***through the force supported by the Complexes.*** In the legitimacy of such a construction, any subjective factor is completely absent, as it is replaced by the power of money, the might of power, the power of sacral and various confessional influences. Moreover, the entire structure of the world control ***was provided and supported by the Control Complexes (the Caucasus and the Alps)***, forming a programmed individual and associated "program-object" mind that orient all people of the planet not to true objective reality, but to artificially created by the System.

At the head of this complex pyramid of world control was a structure of individuals of the Brain **genotype 442** which for correctness of understanding can be called "The **Super Jewish Priesthood.**" By their servants quite a lot of "secret" information was deliberately put (and now it is being put) on the "air". But this is just the psychological technology of their work and nothing more. Through them, as the leading executors of the old Conceptual Power, the strategic program processes of the old Control System were realized, which ensured a stable state of the pyramid of the control. At this stage of development, the methodology of values **GAINED A COMPLETELY DIFFERENT CHARACTER**, in which people's most

valuable and dear – their life ***was determined through the seized social position, the power of money and the might of power.*** Moreover, all the lowest social vices and spiritual impoverishment of the human spirit were acquired during this short historical period of time, "improving" through all five social forms of social organization. And all this anti-human fall at each stage was framed with "the values of the state and the law", constantly putting forward and propagating it as achievements in the development of civilization, especially its basic value basis.

As a special additional organizing tool for social values, ***the programmed impact on people, – the "division of labor", – was used*** as a model construction of social inequality. ***The programmed gaining of the social status and DIVISION OF LABOR ACCORDING TO THE BRAIN GENOTYPES*** played a truly leading role in determining the construction of statehood and establishing all legal foundations for societies being without the participation of the subjective factor and its mind with tough support by the Control Complexes. It was to this target state that the methodology of values, which can be called "People of the Value", was directed. The methodology of values "People of the Value" passed into a special phase of the labor division, creating a future platform for complete enslavement through the introduction of an image of people's existence – "an economic man". In the sphere of power, as well as in the state of the methodology of values, a complicated situation developed. ***Financial revanchism***, having organized itself as a programmed system, just began to gain momentum and was still incapable of taking full power through "the power of money," it needed time, greater legitimacy and large scale. And the "Might of Power", ***with the influential participation of secret orders and clans***, for a number of their internal reasons, significantly reduced its governing effectiveness. It was at this "historical" moment, with the introduction of new mantissas to the Brain, The System, through its Control Complexes, including the Alps 2, created all the circumstances for a significant change in the essence of the program-determining controlling substance of the Ebr Mind state that time, ***GIVING IT AGGRESSIVE DESTROYING CHARACTER*** in everything. It is from this fact, if it is permissible to put it in words, which the degree of deviation from harmony with the primary determinant of the true state of the Supreme Mind reached its maximum limit and was subsequently held at this level ***practically up to 1985*** by various governing incarnations. These incarnations and everything that is connected with them today are becoming the property in the knowledge of their truthfulness, and not what was "interpreted" to all of

us while studying this period since the school bench. That is the way the bloody hundred and fifty years began.

What are they particularly characteristic from the point of view of the methodology of values? Speaking about the true objective causality, it should be said that the comprehension of the surrounding "objective reality" by ***the leading executors from the Conceptual Power*** was completely oriented and framed in the program "**The Might of Power**" for the entire century and a half. As a result of the implementation of this program, the "selected" executors organized and executed a bloody step-by-step path: ***Revolutionism, Militant Fascism and Destructive Democratism***. This period, the whole depth of the "knowledge" sphere was focused only on the development of technologies for the weapons production – from the army saber and bayonets, to weapons of mass destruction and their carriers. The state of the "Authoritative revanchism" in the control sphere, which lasted until 1990, ***allowed representatives of the Brain genotype 442 to implement their program functions in full***. On the bones and blood of hundreds of millions of people they managed to **PREPARE AN UNSHAKABLE AUTHORITATIVE STATE** in all spheres of the world community's being control, create programmed social and governing structures of the local and global plan, ensure the necessary volumes of accumulation and concentration of financial resources control and the converted substitute in their hands, and also prepare another social position for the future "**Golden Million**". The world was preparing for the next inhumanity stage.

From 1841 (to 1946) special attention should be given to the programmed states of "needs" and often changing transitions of the executive state of "labor" to the state of "work". It is essential to understand in principle how the work differs from labor, but also take into account the territorial division of the overall programmed control influence over special spheres of control states, which historians and sociologists are conventionally called "capitalist and socialist systems". It is labor which is an indispensable condition of man's happiness: only in the process of labor does the child born by Man becomes a Man. The secret of labor lies in the fact that all the mental processes, properties and functions of Man develop only in the natural process of spending labor. Human properties: thinking, will, affect, perception – become Human only in the process of an exhausting exercise of mind, will, muscles, which can not be interrupted on one's will because of

fatigue or monotony¹⁴. No surrogate of labor (play, sport) develops the higher mental functions of man, which are the main goal of civilization. Man builds himself by overcoming himself and nature. Labor is a **MANDATORY CONDITION FOR HAPPINESS OF MAN** for the second reason, too: in the process of labor a product (material, intellectual, aesthetic and ethical) is created that has a consumer value. This means that it is vitally important for people. And this product is the subject to pass to another person. There is no other purpose for the result of labor – it is always for others. At the time of passing the result of his labor, Man feels the fullness of being, associated with the self-realization of the subject functions – this is the moment of feeling happiness. People, for whatever reasons cut off from labor and involved in the work, are formed as inferior people and as people who will never experience real human happiness. Today, unfortunately, the work is absolutely prevalent, and the state of labor and all associated with it are unfamiliar to the majority.

1.8. Manifestation in destruction

Our knowledge begins with perception, passes into understanding, and ends with reason. There is nothing more important than the reason. The more we go deep to find the reason, the more reasons we discover, and every single reason or a whole series of reasons seem equally fair to us and equally false in their insignificance in comparison with the enormity of the event, equally false in their invalidity to produce a fait accompli. Mindful of this, we will continue our research, which is aimed at only one thing – to get to the Bath or at least to the dressing room and from there to give assessments of the events in progress.

According to the plans of the Ebr system, the period between **1999 and 2008** was to be special and saturated with various symbolic events. The events of this time that occurred before our eyes, we'll try to comprehend from the point of view of the already read material.

¹⁴ **Monotony** (from other Greek, μόνος "one, single" and τόνος "tension") is a functional state of reduced performance that occurs in situations of monotonous work with frequent repetition of stereotypical actions in a depleted external environment. It is accompanied by experiences of boredom, apathy, drowsiness and desire to change the type of activity. Also characterized by such physiological and psychological symptoms as a decrease in tone, a weakening of conscious control, a deterioration in attention and memory, etc.

I did not give examples of all the available material here due to the inexpediency of its wide publication today. But this, in order to understand all that has taken place, is more than enough.

The state for 1999-11-21 and goals for the period 1999-2008:

1.1. The limit of technical progress is reached on the basis of the knowledge that was given more than 3000 years ago.

1.3. Artificial reservoirs not only interfered with the flow of power, but also created a threat to the Ebr Control Systems.

1.4. Deep-sea hollows, originally intended for studying the structure of the Earth, pose a threat of Earth's explosion.

1.5. Not all the population adequately perceived changes in the Brain octave structures even in the conditions of the completed programs for the period of **1984-1999**. (Some excerpts below).

2.2. A lot of traces of seizure remained on the Earth, which could result in inadequate actions in conditions of the Brain octave growth. All traces for the creation of mankind should be only on the territory of Israel.

2.6. The motion of the Earth must occur in full accordance with the laws of Heavenly Mechanics, for which the flows of power must be properly located. For this, it is necessary to remove the Panamanian isthmus, completely remove the territory of Suez, part of the water surface (about 1 km thick). The Isthmus of Panama is an artificial hydro technical structure built less than 14,000 years ago. Estimation of the ice age beginning should be shifted to 6000 years ago with respect to the known date imposed on us by historians. Liquidation of the old Complexes in conditions of unavailability of new ones, as well as non-observance of the conditions for the flow of potentials, led to the urgent creation of the Panama Isthmus that distant time. The Andes Complex provides conditions for the existence of the Panama Isthmus. In addition, there should be removed the land that can not be used in the future (Africa and part of Eastern Siberia). The center of the Earth should be located below the center of mass, and not vice versa, as it is now.

3.7. The population of the Earth should be reduced to the number that is to be transferred to the site.

4.8. The entire population of the Earth must be under unified control, all types of experiments are to be stopped with the elimination of the intermediate genotype, to which all conditions were created.

5.9. The unified financial system should be built on the basis of the Control and Audit Office with all the necessary powers and possibilities.

6.10. The Earth protection system should be independent (it should not be subject to accidental external influences).

***** Help on item 5**

In 1984, the Ebr Control System has started formation of a new Brain. It was allowed to use catalysts such as drugs and alcohol. Taking into account the unsuccessful experience of **1927-1932**. on the changes in the structure of the Brain in the US, it was necessary to ensure that the part of the population that was to be subjected to experiments used drugs and alcohol. For this purpose, "the replacement in the control" was urgently carried out in Russia. As it happened among the personalities, many of the readers remember. The new leader (M.S. Gorbachev), through a fictitious ban on alcohol, led to the fact that **PRACTICALLY ALL POPULATION ON THEIR OWN** began to make everything necessary, while all the elite varieties used earlier as a food additive were destroyed. The appropriate permissive decrees were adopted later. Gorbachev's great service is that in a short time he achieved the indispensability of alcohol and drugs and complete dependence on them. Thus, by 1999, the platform had been prepared for mass experiments on the peculiarities of the new Brain formation.

***** Help on pp. 1, 3, 4, 5, 6, 7, 8, 10**

All items marked as targets were to be completed by **Easter 2008**. The execution was recorded to all Earth Control Systems.

***** Help on item 9**

For the purposes of CAO formation, Chubais was "created" and involved, but in 2002 it became clear that he did not have the necessary frequencies to have a permanent communication, and he was "deleted" from the list.

The CAO was to be formed only by those who were "planned" for the appointment of Moshiach with full authority in the Control Systems.

***** Help on item 2**

Traces of the former civilizations, traces of wrecks of objects should no longer bother that part of the world population that was to be saved. The work to eliminate these traces was entrusted to the Kailas Complex and the Greenland Complex.

Complex of measures:

- urgently to make replacement in the control system, **to REMOVE TALENTLESS AND STUPID EXECUTORS**, to charge with this mission a specialist from the special services with the ability to properly manage finances: **Yeltsin → Putin**;
- Develop a strategy for warfare with the elimination of all traces on the territory of Iraq, create all conditions for warfare under the cover of terrorism;
- on the basis of pre-prepared materials (terrorist N 1, weapons of mass destruction, etc., up to bribery, erasure of the Brain) to ensure the conduct of operations so as no one has any doubts about anything;
- to stimulate the activity of all special services, to develop and create everything necessary for them to interfere in the work of any structures; at the head must be only those who correctly understands the work with finance;
- to develop a strategy for the elimination of all traces of the war in Iraq.

***** Execution of the Program under item 2:**

- Putin urgently got at the at the control, all items of the program for special services are carried out;
- the object for committing a "terrorist act" was selected a few weeks before the events and was insured for a double sum – you already guessed what kind of object it was... September 11, 2001 in the United States, suicide bombers of the terrorist organization Al-Qaeda captured four passenger airplanes, directing two of them at the symbol of business New York – ***the towers of the World Trade Center***, and two others – to the Pentagon and, presumably, to the White House or the Capitol.

All the planes, except the last, achieved their goals. The fourth captured plane crashed into a field near the town of Shanksville, Pennsylvania.

On the day of the "terrorist act", **ALL JEWS WERE WARNED** and did not come to work (supported by the Mossad); unmanned aircraft, explosives in buildings had been prepared, and everything worked simultaneously (CIA, FAS); the lack of all types of communication was provided, information messages with cartoons were prepared in advance.

Within six months, a racket was kicked up, and – an attack on Iraq, as a country in which there are many terrorists. Russia did not take direct

participation, but "the ears began to get out" in 2007, especially after the trips of Primakov (FAC). (Why do we consider this "episode" of solving the tasks posed, through specific people? Only because it has already become history, and many of the readers remember very well what was happening).



These are opinions (of those who at that time had already been to the Dressing room) after watching the television show "The attack of terrorists on America":

- all the media were pre-prepared and filmed the attack from the right points and in the right perspective;
- a message that the aircraft approaching the building without windows, was later erased as an annoying misunderstanding;
- there were three major brokerage firms dealing with securities: Cantor Fitzgerald, Eurobrokers and Garbon Inter Capital at the World Trade Center. On the morning of September 11, at 8:46 am Flight 11 plane crashed into the North Tower directly under the floor where the office of Kantor Fitzgerald was located, which is the largest dealer in the US securities market. Shortly thereafter, a strong explosion occurred under the FBI office in the North Tower on the 23rd floor, the Garbon Inter Capital office on the 25th floor and in the basement of Tower 1. The explosion caused destruction and a severe fire on floors 22-25. The fire on the 22nd floor was reported at 8:47. Soon after this, at 9:03 the flight 175 crashed into the South Tower directly under the floors on which the Eurobrokers office was located. In all

three cases, explosions and fire destroyed offices on several upper floors. At 9:37 am flight 77 flew into the Pentagon building, aiming at one of the few offices that moved to the newly reconstructed part of the Pentagon: the Office of Naval Intelligence, which investigated financial transactions, related to securities, transactions performed by those dealers on Securities in the World Trade Center, which became a target. 41% of the victims in the twin towers were employees of two companies that operated with US government bonds: Kantor Fitzgerald and Eurobrokers. 31% of the 125 victims in the Pentagon were employees of the Navy Command Center, which housed the Office of Naval Intelligence. 39 of 40 employees of the Department of Naval Intelligence were killed. In the repositories under the World Trade Center, all bond certificates were destroyed;

- On the same day (Sept. 11), the Securities and Exchange Commission declared a state of emergency in the country and for the first time in the USA history demanded emergency powers under section 12 (k) under the Securities and Exchange Act and mitigated legal restrictions on clearing and redemption of bonds for the next 15 days. These changes allowed the repayment of secret government bonds of approximately \$ 240 billion after the payment deadline (September 12), – without the usual regulatory control to identify the owners;



- a cruise missile flew into the Pentagon (photos can be found on the Internet);

- the opinion of "experts from concrete" (expressed on Russian television) that kerosene explodes can be attributed to the usual delirium – there are no traces of kerosene explosion even on the materials shown (and

can not be, since unmanned aircraft had a fuel supply only to reach the target, and the necessary amount of explosives to create the effect of an external attack);

- Based on video materials, buildings were demolished by demolition specialists;

- The only passenger aircraft was destroyed (along with passengers) **by the orders of Bush.**

1.9. Comparing the available

"You can not see a person face to face. The big one is seen at a distance..." – the Russian poet Sergei Yesenin wrote once and for ever. This is indeed so. The more time passes from the memorable day of September 11, 2001, the clearer the picture of the events that took place then. And there is less and less doubt that ***American society and the whole of the world became victims of a grandiose provocation, a real "falsification of the century" that has changed the content of the Ebr system of parasitism and violence. Parasitism, being in need of violence and "paid" for it, after the September events, had to "share" with "violence" an obviously significant part of the sources of financial recourses, significantly expanding their "power", further strengthening the foundation of the Ebr system, the destruction of which now is impossible without eliminating both "components" that permeated the whole system of social and economic relations.*** It was possible to carry out all this only with the direct participation of the US Army and special services, as well as with the benevolent neutrality of big business and big politics. No other version of the **"9/11 catastrophe"** can answer all the questions arising from more or less careful study of the events of that significant day. Murder will out.

When the United States, with Bush's pass, was in fact bogged down in Iraq, in accordance with the plan of actions discussed above, we can recall the words of the holy prince Alexander Nevsky: ***"God is not in power, but in the truth"***. And we must do our best to see this truth behind the thick covers of artfully and professionally prepared lies. Let's make at least the first step in this direction. Perhaps, it will seem "long" and uninteresting in its sequence for many of you, then just skip and go further if the desire to go this

road still remains. If not – just close the book and, forget it, – live the life that you are used to living. It's always your right.

Here is a quote from George W. Bush, September 11, 2001. "These acts of terrorism are crushing steel, but they can not destroy the steel of American determination." **9/11** – under the sign of these figures for six years now, without exaggeration, there has been the entire modern world. The seizure of four passenger aircrafts (first reported as eleven), the death of thousands of people in the Twin Towers of the World Trade Center (**WTC**) in New York, and the attack on the center of American military power – the Pentagon – have become such a symbol of absolute evil which in the global information space, is second only to the Holocaust. **At 10:00**, just an hour after the second plane crashed into the southern tower of the WTC, British Prime Minister Anthony (Tony) Blair stated: *"This mass terrorism is the expression of a new evil spirit in today's world. It comes from fanatics, for whom human life does not cost anything, and we, representatives of democratic societies of the world, have to unite for a joint struggle to destroy this devil"*. It should be said that this was the **FIRST IN TIME INDICATION AT A NEW SOURCE** of the world evil. The 43rd US president, George W. Bush, was preparing for a flight from Sarasota, Florida, to the US Air Force base in Barksdale, Louisiana, where the news of the tragedy found him; and in his first address to the nation he was not that categorical: *"There was a national tragedy with a mass death of people; we encountered an enemy that we have never encountered, perhaps this is a terrorist act"*. In his second public speech, which began at **13:04** already at the base of Barksdale, he was more informed and determined: *"We assure the people that freedom will be protected. Without any doubt, the United States will find and punish those who committed this terrorist attack."* And, finally, at **20:31** from the Oval Office of the White House there began broadcasting the next, already the third in a row for this day, US President George W. Bush's address to the nation. He said: *"These acts of massacres were aimed at plunging our country into chaos, but they have not achieved the goal. Our country is strong. Terrorists' attacks can shake the foundation of our buildings, but they can not shake the foundation on which America stands. These attacks are crushing steel, but they can not destroy the steel of American determination. America has become the target of the attack, because it is the brightest light of freedom and equal opportunities in the world. And no one is able to switch off this light. Almost instantly, on the same day of **September 11, the blame for the incident was placed on Muslim terrorists from al-Qaeda**, led by Saudi millionaire **Osama bin***

Laden. Experts and officials quickly agreed that of the three suspects: the Colombian drug cartels, the Palestinians and al-Qaeda, "to carry out such an action", in the planning and organization of which hundreds of people participated, training took several months, and among the criminals there were people, who had accurate information about the design of the attacked buildings and professionally managed civilian aircraft, "could only the latter.

As early as **October 7, 2001**, the first "retaliation action" of America was launched against Afghanistan, where, allegedly, under the auspices of the Taliban, al-Qaida support bases were stationed. Such a short time for the preparation and successful conduct of a very large-scale military operation can not but surprise. They mean that either:

a) the US troops were ready in advance for carrying out such actions (a variant – they are ready for them anytime and anywhere in the world), or:

b) the official Washington had full guarantees that the Taliban, already "demonized" by the global press, would not have a serious military and political resistance, and would pass control of the power in Kabul to American "avengers".

The further development of events is well known: the fight against international terrorism and the "besieged fortress" syndrome in the US, the American "gi-ai" in Afghanistan, Central Asia and Iraq, the "color revolutions" in the post-Soviet space, the aggravation of the situation in the Middle East, the threat of war with Iran – all these are **DIRECT AND INDIRECT COSEQUENCES OF THE EVENTS of September 11, 2001**, which have become a kind of "bifurcation point" of the whole world history.

It should be noted that the previous "bifurcation point" the world history passed only ten years earlier, during the events of **August 19-21, 1991**, when the Soviet Union was destroyed as a result of the collapse of the State Emergency Committee. ***And from now on, these two dates, August 19, 1991 and September 11, 2001, will be inextricably linked:*** perhaps not only indirect spatio-temporal, but also direct cause-and-effect relationships.

There are many details and facts that categorically do not fit into the official versions of the events that took place on these two days. And if in the case of the Emergency Committee to find evidence and confirm such inconsistencies is rather difficult: a serious "sweep away" was not only in archives, but also libraries, then in the case of stolen aircraft, the situation is

much more promising. Still, 2001 is closer to us for exactly ten years, and this is already the "Internet age", when the possibilities of searching, transmission (exchanging) and storing information have grown immeasurably. Therefore, comparing the available data with the official version of the 9/11 events is not an exceptional effort, this work has been done by a significant number of people and organizations – primarily in the United States itself – and is available in a number of Internet sources. But this is a purposeful and emotionless work in assessing the "scooped" information from a specially "spilled sea", in order to hide, complicate and minimize that factual which has leaked into the public sphere. Such work (and this is work) – is a certain first step of determination to get into *the dressing room*. Some results of this work are offered to the readers.

1.10. Supplement to the explanation

The official chronology of the basic events of September 11, 2001 – in the most concise statement – is as follows:

07:59 (according to other sources 07:55). The American Airlines flight Boeing-767 (flight AA11) flew from Logan airport (Boston, Massachusetts) and went on a course to Los Angeles. On its board there were 81 passengers (approximately 39% of the load), two pilots and nine crew members.

08:01 "United Airlines" Boeing-757 (flight UA 93) left Newark airport (a suburb of New York, New Jersey) for San Francisco. On board it has 26 to 38 passengers (about 16% of the load) and 7 crew members.

08:10 American Airlines flight Boeing-757 (flight AA 77) takes off from Dulles airport (Washington, North Virginia) to Los Angeles. On board it has from 50 to 58 passengers (about 27% of the load) and 6 crew members.

08:15 The United Airlines Boeing-767 (flight UA 175) departed from Logan airport (Boston, Massachusetts) to Los Angeles. On board it has from 50 to 58 passengers (about 27% of the load) and 6 crew members.

08:45 AA 11 crashed into the 110-story north tower of the symbol of America – the World Trade Center – at the 84th floor of the skyscraper, having made a huge hole in the building. After the crash a powerful explosion was heard, the skyscraper caught fire.

08:55 President Bush, who is in Sarasota, Florida, is informed of the incident.

09:03 UA 175 crashed into the south tower of the World Trade Center.

09:15 The first speech by George Bush "in connection with the emergency in New York.

09:25 The US Federal Aviation Administration has closed all airports in the vicinity of New York. **09:26** CNN said that in New York, a terrorist act had been committed – two planes crashed into the twin buildings of the International Trade Center. **09:27** Former US expert, former spokesman for the National Transportation Security Administration, Ira Fuhrmann, said that the collision of two planes with the towers of the international center in New York is probably intentional.

09:35 All the bridges and tunnels of Manhattan are closed.

09:40 The US Federal Aviation Administration has banned all flights of the territory of America. All aircraft in the US airspace were ordered to land immediately.

09:55 The AA 77 plane crashed into the Pentagon building. Witnesses said they had seen an airplane that dived onto the west wing of the Pentagon. The building started a fire; it is shrouded in clubs of black smoke.

10:01 Washington is evacuating from the building of the US Congress, as well as all official institutions located in the US capital. In New York, the New York Stock Exchange is closed and the entire Manhattan is cordoned off. The towers of the World Trade Center are covered with a flame and thick clubs of black smoke, the streets around in a radius of several hundred meters are littered with debris. The number of victims is unknown, the nearby schools, in which the classes are terminated, have been turned into staffs to assist the victims and eliminate the consequences of the terrorist attack. Evacuation of staff from the UN headquarters is in progress.

10:05 The southern tower of the WTC collapsed.

10:05 President Bush leaves Sarasota. A fire is in the Pentagon building in Washington, the White House is evacuated. According to CNN, a military helicopter crashed into the Pentagon building.

10:06 CNN reports that in the building of the State Department there was a fire, the building was evacuated.

10:15 A part of the Pentagon building collapsed.

10:24 The US Federal Aviation Administration reported that all transatlantic flights were redirected to Canada.

10:25 UA93 aircraft crashed in Somerset County, 130 km southeast of Pittsburgh.

10:27 CNN reports that the Pentagon announced the highest degree of alarm. IT MEANS **READINESS** TO WAR.

10:27 The northern tower of the WTC collapsed.

10:41 The west wing of the Pentagon collapsed. There is a strong fire in the building. Explosions are heard.

11:00 It is reported that the plane crashed into the country residence of the US president at Camp David. Later this information was refuted.

This way played patience, everything seems to be right, and everything seems to agree, but through obvious distortion of some "cards". First of all, the departure of the UA 93 aircraft was delayed, and it took off only at 8:41, just a few minutes before the first airplane had crashed into the northern WTC tower. The fact in itself seems to be insignificant, but in the light of further analysis, it is possible that it has a very serious subtext. The very situation in which 19 "Islamic terrorists", armed only with knives for cutting cardboard, are almost **SIMULTANEOUSLY HIJACKED FOUR AIRCRAFT** of civil aviation, looks more than improbable. Even less likely, the alleged "hijack pilots" Mohammed Atta, Marwan Al-Shehhi and Hani Hanjour, who in the summer of 2001 underwent short-term flight training on single-engine Cessna-172 aircraft, but were recognized as instructors unsuitable or limited to their piloting, managed to carry out such complex maneuvers that led to the UA 175 aircraft getting into the southern WTC tower, and the AA 77 aircraft to the Pentagon building. After all, according to the official version quoted in the International Herald Tribune (October 17, 2001, p. 8), the AA 77, which crashed into the Pentagon, performed a 7,000-foot drop over Washington with a 270-degree turn at a speed of 500 miles per hour. It approached the Pentagon along a horizontal trajectory (to inflict maximum damage to the building) at such a low altitude that it tore off the wires that ran through the street (***and somehow managed to squeeze between the pillars***, the distance between them is smaller than the span of the wings of the Boeing-757 aircraft).

In general, the AA 77 attack on the Pentagon is perhaps the most "weak Link" of the official version of the 9/11 tragedy. Even photos from the scene confirm that the observed damage to the building of the US Department of Defense could not have been caused by a "suicide airplane". Compare, for example, photos of destruction in comparison with the scale of the Boeing-

757 aircraft. It is very indicative that at the site of the crash from the very beginning, there were absolutely no details of the fuselage of the aircraft and its equipment: for example, engines, wings, tail part and so on. As they say, find in the photos, which are full on the Internet, "Boeing-757" and "entrance hole" from it! They are simply not there. As there are no traces of bodies and baggage of passengers of the flight AA 77 (they were allegedly identified "on the remains of DNA"). But there are undisturbed coils from the cable, whole windows over the impact site and even a photo of an inlet about 2x3 meters in size, to which the hundred-ton aircraft (!) has slipped without a trace, and also an output hole wider in comparison with the entrance one.



And "at the exit," as you can see from this photo, for example, hang the fragments of the armature, which is typical for a missile strike. It is also interesting what exactly "exploded" inside the Pentagon, as it appears from the message marked **10:41**?

The above materials are enough to conclude: the plane and passengers of the flight AA 77 had nothing to do with the attack on the Pentagon. But in that case – where have they gone? **And where have 7 more gone of the allegedly 11 aircraft captured on September 11**, reported several times by the largest American media, including the CNN television channel? And what kind of planes they were, who hijacked them, what is the fate of the terrorists? I note for the curious that there **has not been answer to these questions until now**. We assume that behind this silence there lies a certain area of emptiness and errors – but nothing more. However, as for the four above-mentioned flights, they can not be dismissed in this way. And if someone tried (and continues to try unsuccessfully) to falsify the history of

the AA 77 and its "attacks" on the Pentagon, if someone managed to hide (or, what is the same, to destroy) the plane and its passengers, he, this "Mysterious subject", by definition, can not be either a subordinate of Osama bin Laden, nor Osama bin Laden himself. Here, obviously, the forces are much more serious, comparable to the government or even higher, level.

TAKING INTO ACCOUNT ALL THESE CIRCUMSTANCES
the "conspiracy theory" arose almost immediately after the events of **9/11**. Many points of the "main line" connected with the indisputable airplane attack on the "twin towers" of the **WTC** also spoke in its favor. And first of all – sudden collapse of these structures, and attacked 18 minutes later and at an angle South Tower, carrying steel columns which were guaranteed not to be affected, fell 22 minutes before the North Tower. If the cause of collapse had been the deformation of the bearing columns due to the fire, everything would look quite different. However, such a deformation would contradict all the known laws of physics, since the temperature in the foci of combustion did not even reach the first critical threshold in the steel structure – 550 ° C. In addition, the very nature of the destruction of the towers, which almost completely "laid down " without any large fragments, does not correspond to the picture that had to be observed according to the official version of the catastrophe. The most mysterious looks – even if we admit that aviation kerosene burning in conditions of lack of oxygen, is able to melt the steel, – almost complete destruction of the bearing steel columns of the WTC tower structure below the attack level. "When the floors collapsed, these central steel columns a quarter of a mile high (at least from the ground to the site of the fire) had to remain standing, naked and without support, and after that they had to fall down entirely or in pieces, destroying the buildings hundreds of feet from the WTC, like giant trees that are felled in the forest. "But I did not see a single photograph of these columns, wherever they stood, fell or lay on the ground, "wrote one American author who investigated the **9/11** problem, J. McMichael. But everything described fully corresponds to the pattern of buildings destruction by a series of one-stage high- explosions – since it is high- explosives that can turn into dust and small fragments such materials as steel and concrete. It will be interesting to note that the company whose employees first appeared on the site of the WTC fall – to take away the remaining wreckage – is the same company that demolished the ruins and took out the debris of the blown up Murrah building in Oklahoma City. This company is called "Controlled Destruction". Well, – is there anyone else who realized that the World Trade Center was destroyed not by the aircraft attacks? The thinking reader may

well imagine such a picture – the plane crashes into the first tower, making a break in the uppermost part.

Then quite expected things take place:

- the tower remains standing – the building of reinforced concrete is extremely strong, the terrorists have already blown up a large bomb inside the same building without much damage;
- the second plane crashes into the second tower below and at a higher speed; it makes a larger hole in it, fragments are falling into the streets, but the building, nevertheless, stands and looks quite solid;
- the second building begins to burn, also up from the collision site; about half an hour later the fire in the first building "goes out" – it is still smoldering, black smoke is coming out, but there is no flame...
- the fire in the second building was extinguished;
- the second building suddenly crumbles into the dust, like a smooth wave ran from above the building (above the burning point) down through all floors at the same speed, the fragments mostly fall inwardly, the whole pieces do not fall off the building and do not crumble to the surrounding houses – the destruction began from the top (above the collision site), it goes evenly, all the structural elements are destroyed sequentially, so that there is no supporting skeleton. The destruction is uniform, symmetrical and absolute.

To summarize: all this looks like pulling down – because that's what it is.



The first tower is falling down as a result of a similar "wave".

There is no doubt that the aircraft crashing into the towers caused serious damage. But remember the show on TV and take a look at the pictures – these buildings are just "razed to the ground". To demolish a building does not require a lot of explosives, but it should be put in the right places (in the direct contact with structural elements) and undermined in a uniform, synchronized sequence...

There are also indirect data that some high-ranking representatives of the American intelligence services could know about a possible attack against the "twin towers" and somehow inform the new WTC owners about it, who purchased the complex just eight weeks before the disaster at a price, approximately twice (3 billion dollars instead of 1.5), and nevertheless received insurance that covered their losses. In addition, on September 6-7, 2001, 4744 put options (assuming that the shares would fall) were bought for shares of United Airlines, compared to only 396 call options (assuming that the shares would rise). These are abnormal indicators. Many of the UAL put-options were purchased through Deutschebank / AB Brown, until 1998 managed by the CIA chief executive A.B. "Buzzy" Krongard. But the investigation of this fact was "put on the brakes".

Analyzing all these discrepancies, American independent experts within the framework of the version of Carol Valentine – Leonard Spencer came to the conclusion that the attack of WTC towers was made not by United Airlines and American Airlines flight planes, but specially prepared for this action remotely controlled airplanes " doubles ". The technology for such remote control exists; it was developed by Northrop Grumman for use on a Global Hawk plane, an American unmanned military aircraft with a wingspan like Boeing-737. However, it is almost impossible to use it with the intended purpose on commercial airline flight planes – there is too much risk to uncover the whole operation. Therefore, a different technology was applied:

- four passenger airliners (flights AA 11, AA 77 as well as flights UA 93 and UA 175) take off but after a while pilots under an assumed pretext are ordered to land at the designated airport with a military presence;
- two pre-prepared aircraft with remote control (one of them – "Boeing-767", painted in the colors of "United Airlines" and loaded with aviation fuel) take off and are sent to intercept flight routes AA 11 and UA 175 to deceive air traffic controllers. These (duplicating) planes then fly to Manhattan; the first crashes into the North Tower, and the second (18

minutes later) – to the South Tower. People from three Boeings are transferred to the fourth (UA 93). This liner takes off and crashes over Pennsylvania.

Here is the chronology of events in this version:

7:59 Flight AA 11 takes off from the Logan airport in Boston.

8:14 Flight UA 175 takes off from Logan airport in Boston.

8:16 The first deviation of AA 11 flight north of Albany, New York.

8:20 Flight AA 77 takes off from the airport Dulles in Washington.

8:20 Answering machine AA 11 turns off.

8:30 First substitution: AA 11-X appears, answering machine is off.

8:35 Start of the flight control center recording in New York.

8:40 The UA 175 flight answering machine is turned off.

8:42 Flight UA 93 takes off from the airport Newark, New Jersey. The first deviation from the course of UA 175 flight over the north of New Jersey.

8:46 Second substitution: the AA 77-X aircraft appears with the same answering code.

8:46 The AA 11-X aircraft crashes into the northern tower of the WTC. A nationwide alarm is announced.

8:53 The third substitution: UA175-X aircraft appears, the flight answering machine is disconnected. A real AA11 flight lands at Harrisbur Airport.

8:54 End of the recording of the flight control center in New York.

8:55 The flight answering machine of AA 77-X is disconnected.

9:02 UA 175-X aircraft crashes into the southern tower of the World Trade Center. A real UA 175 flight lands in Harrisburg. Fourth substitution: the UA 93-X aircraft replaces flight UA 93.

9:07 UA 93 flight lands in Harrisburg.

9:09 Flight AA 77 lands at Harrisburg.

9:45 Flight UA 93 with passengers of four flight takes off from Harrisburg. Before that, some of them, being at the airport, for someone's request, are calling by mobile phones, and confirming the fact that the plane was hijacked by terrorists.

10:06 Flight UA 93 crashes (or shot down) next to Shanksville (Pennsylvania). So, according to Reuters, Pennsylvania police officers reported on Thursday, 13 that fragments of the UA 93 aircraft were found at a distance of up to 8 miles (from the crash site), and local news media quoted local residents reporting on the second aircraft in the area (it was F-16) and about the flaming fragments falling from the sky. That is, the UA 93 aircraft did not just "crash", but was blown up in the air. By the way, on September 16, 2001, US Vice President Richard Cheney said that on September 11 George W. Bush had ordered the plane to fly to Washington (UA 93) and two F-16 fighters took up, but supposedly "the pilots did not have to bring the order to the execution, because thanks to the courageous actions of the passengers and the crew of the Boeing, the terrorists' plan failed. The hijacked plane crashed in Pennsylvania. It crashed so as its flaming remains, falling from the sky, were picked up in a radius of 8 miles. Chaney also said that it was he who recommended the president to order the military pilots to shoot down UA 93, and Bush had no choice but to take this "difficult decision". And if the reader thinks that this version is closer to the truth than the official version, and then he will certainly come to the conclusion that we are dealing with a grandiose "falsification of the century". And if everything that is happening within the framework of such falsifications of events that are taking place before your eyes, and which are already taken for history, transform into everything that we see today in the world and around ourselves, then the conclusion will be fair, that the price to the modern United States as a "global leader" and "a light of democracy around the world" is a broken cent, ***and all of its history should be rewritten (brought into line), and not from September 11, 2001, but from more distant time. And I am more we will live up to this time.***

However, at the end of this chapter, I want to note, in my opinion, an important thing – in search of the truth, unfortunately, we are more attracted by the confirmation of our own convictions than the truth itself. For some, the search for the truth is limited to the inquiry in Yandex, someone fearing the possibility of making a mistake altogether turns away from the search for the truth. Academicians are proud of the fact that in search of the truth our logic, our emotions are left aside, at least, so many of them think this way. Therefore, I ask you, readers, to take into account that the truth is a purely human interpretation of facts. ***And it all depends on you: the way you understand the truth, and whether you accept it as a fact, not forgetting that this is the way to the Bath.***

Chapter 2. Claim for a title

– And where do you keep your books?

– I do not have any. After reading a book, I give it to my friends, and they do not bring it back, as a rule.

– I considered that a writer lived among the shelves crammed with books. He was looking at me with some doubt:

– Are you sure you are a true writer?

The fact that it is useful to read, to read useful books is double useful, and the benefit of reading very useful books depends on only the amount of the read – it is easy to make sure of it by the books reverting to which guarantees that very benefit each time when you take them in your hands. And every bit of new thinking, doubts, impulses to search and the results of new findings in already repeatedly read pages, out of which, it seems, you do not expect to have anything new, is the way of gaining some elements of consciousness in the direction of "building up" the Mind. However, nowadays there is (i.e. left by the previous system) a great number of people with limited thinking. It's not their "fault, they "were made" such. Most of them are united in one way of thinking. And this is an indicator of the "successful implementation" of that plan which was conceived two thousand years ago. People have become "invincible in their stubbornness." But now all this mass (please, do not take offense) is falling apart, – though slowly, but I do not pretend to being objective in this assessment,- to thinking individuals (people who started thinking). Many of them still move to the right or left of the true path in their development – when the ground is cut from under people's feet because of the cognizable. The only way out which seems to be reliable is to find support in something that is stable and habitual (and this can only be the image of a narrowly oriented thinking that has been previously inculcated for lack of anything else); it is also possible to unite with like-minded, building up certain islands in understanding the ongoing, which are different from the whole surrounding mass. After all, from the moment of our birth, we all found ourselves in this ocean of world lies – of the rulers, churchmen, financiers, teachers and our own family. The whole society is lying, with a few exceptions, but recently the so-called "ruling elite"

and, of course, the official church, which has already become a commercial enterprise with up-to-the sky ambitions for the control functions, are particularly successful. Should the people who have started their own timid movement on the way to understanding the events taking place, be blamed for the inadequacy of their way of thinking and the actions resulting from it? Or is it sufficient to demonstrate to them, all this lie in the form it exists and develops – without unnecessary philosophical reasoning, resentment and emotional storms? Strictly speaking, everyone has its own islet of security, from which it is frightening to go into the unknown. So, from someone's point of view, anyone who expresses some kind of his own (or imposed) view, inconsistent with other views, or having his (imposed or borrowed) position, different from the accepted one is a complete ignoramus, in the opinions of those who consider themselves to be learned. In this respect, we all are, to a certain extent, hostages of our inferiority, but one and all – "for the sake of a better life..." or something like that, but the very concept of this better life and what to apply it to – is different in everyone. Try to find the right way in such a labyrinth – so that not to incense the fighters for the idea, and the fast liners could not feel the dirty trick, and the thinking individuals increased in their number, and those with limited thinking **STOPPED STICKING TO THE PAST** and at least looked in the direction of the present. As soon as some excess of zeal is shown – either a riot for the eternal familiar truths, or a march towards exorcism with a vulgarly atheistic response, or reinforcement of the usual positions on all fronts – and all around is stir, screams, fights, victims, attacks, divisions of manna from heaven – in general, a lot of noise, no one "is indifferent" – but all are in the wrong direction. The number and speed of the facts obtained today is immeasurably higher than their comprehension. The collectors of facts and small details came to the fore, lacking the ability to see the interrelation of things. Actually, now everywhere there are heaps of repeated information. Wherever you look – you see all the same under various sauces. To find something necessary or just new is actually unreal for many people. To pull out the original from this heap is also unreal. People aloud and in writing repeat a small set of short and worn out logical chains in different interpretations that are convenient for their understanding, covering them with any size of holes in their knowledge and not caring about the reasons for their appearance. At best, everything ends with a conscious dead end, when after the last "and..." you realize that you are stuck.



A few decades ago, the value of information was significant, because it, the information, was obtained with great difficulty. Those who were busy concealing information, distorting the events taking place, including the writing of the so-called hisTor(ah)y, decided not to hide information, but to make people get drowned in information. That is what we are observing today. Against this background, a great bunch of scientists fights for the inadmissibility of scientific authorities' criticism. And not all of them – for the sake of their warm, well-paid posts, many – for the sake of the idea, and if "for the sake of the idea" it is supposed to be holy and righteous – no one is allowed to encroach upon it. In the world there is a certain vanity fair of science, where the number of leaders of scientific collectives (with academic degrees) per head indicates "high development of society", as these leaders believe. But the trouble is that all these academicians, as a rule, are not engaged in science at all, but are in fact scientific managers in the distribution and making money for the equipment and research of their collectives in order to provide themselves with well-to-do and secured existence.

2.1. To open the opened door

Science, like the society, being formed on the basis of knowledge approved by the same society, is like a room with many doors. But only the one who brings the world New Knowledge which does not fit into the paradigm of established and accepted standards of the modern era is able to open at least one door. The scholars and academicians of the present-day knowledge, unfortunately, not only unable to open the door to New Knowledge, they do not even see the doors. They are satisfied with everything, all the answers are found in the form of theorems and postulates,

and if some discoveries take place, they are in fact not discoveries at all, but only make it possible to expand the range to the old, or, speaking of the room, they expand the limits of the room space. At the same time, the walls, the furniture, the floor and the ceiling remain the same. However, those who consciously seek to take the Bath, those who embarked on the path of enlightenment by Knowledge, can not only see, but also find the door handle and the key, and look where **RAS**, with the best will in the world, is not let to come into contact with the Truth. Most directories and, of course, the Internet work on the principle of teaching mentally handicapped children. They do not teach to think, but lead them from link to link, letting them memorize the text, but not comprehend it. Science works the same way: Academician Titov refers to the works of Academician Leonov, and Academician Leonov refers to the statements of Academician Popov, who has read all this from Academician Titov. The circle is closed and the author of stupidity can not be found, and the information itself is defined as absolutely tested – it is not necessary to doubt it, because Titov, Leonov and Popov are people who are trusted by the society. But if you look carefully at these academicians, you will see that they took ***all these surnames in their mature years***, since Rabinovich, Schneerson and Kuperman sounded politically incorrect. Here comes the legend of God's selected and wisdom of the Jewish people, and the Encyclopedia is no longer a reference book, but the revelation of the Torah. This is a kind of erection on the Jewish question among people in science. We'll talk about this a little later.

We are living now at the time when we see firsthand an earthquake in the foundation of the false room in which everything was done so that there could be no place for understanding, developing and improving mental and thinking activities of people. However, for entirely objective reasons and the ongoing processes, new opportunities began to appear making it possible to look at all this with different eyes. With the eyes in which there is a question. Learn to question everything. Quietly and with no emotions, which "lie heavily" on the Mind. Where there is no doubt there is fanaticism. ***Doubt is the way to the truth: he who does not doubt – can not see, he who can not see – can not understand, he who can not understand – is blind and in error.*** Doubt is a cleansing process. It throws out all the unnecessary trash brought by parents, priests, and teachers, politicians, Wikipedia's, various "authorities..." (here you can add something of your own). If you feel that the information does not correspond to your worldview, **WITHOUT PITY, PART WITH IT, even if it is true.** Time will come, and you will return to it, but you will be more prepared for its perception.

Remember – when clearing the Mind of unnecessary things, the most important is not to start examining them. To the trashcan, to spam – and re-discover the searching man in yourself! The one who looks at the rain with his own eyes, and not with the eyes of the moldy scientist-discoverer in the back room of the laboratory, who has long lost touch with the world and common sense. Your task is to awaken this child in yourself and from this moment on there begins an amazing world of truth for you without postulates and canons of hemorrhoid colic of public lawmaking. And it remains only to properly "tie" the "**SvetL**" **Broom** and run to the **Bath** with it, realizing that everything that happens in real life must be viewed through the prism of the **INFLUENCE OF THE FUTURE ON THE PRESENT**. ***Not the influence of the past on the present, not the influence of one present on the other present or of the past on the future, which alone determines the present.*** You should understand, my dear reader, that the future determines the present – like a draft, like a project. Calculations determine the appearance of a new airplane or a nuclear reactor. If we draw an analogy, say, with the construction of a bridge or a space rocket without a project, then the bridge or the rocket are images of the present, and the project is the image of the future. Contrary to the opinion of lazy and ambitious heirs of orders and gold, ***future is not what is coming to us, but what we are going to.***

2.2. Decisions and circumstances

If Einstein researched into the world without man, and Freud – man without the world, then Marx was engaged in the links between the world without man and man without the world. So we got the society that personifies such a link. So, a Man. A discrepant complex creature, endowed with unique abilities and needs – ***bodily and mental***. The basic requirement of the body is the instinct of self-preservation. Man wants to live. This desire is not based on logic and advantage, it is an inalienable property of our nature, and to be more precise, of course, it is determined by the imperfection of our body (shirt) after the interventionists "decision" to recreate it. All the desired life "parameters" were not achieved by them. The strongest bodily passion is subdued in the face of the threat of death, its inevitability, only, in my opinion, due to people's misunderstanding – why everything ends this way, and not otherwise. Perhaps this is because of the fact that for the present Man it is more important to "conquer", "posess",

"consume"., but not to understand. But misunderstanding is usually followed with fear. Man's fears tell much about Man. I have collected quite an archive of these fears after I started working on the **"SvetL" Technologies** – and I realized what it was and what it was for. The basic requirement of the Brain (Spirit, Soul) is **self-esteem**. Every Man knows his own worth. Everything else moves around this value. The aspiration to match the level of merit that we have awarded ourselves, subordinates our thoughts and desires. Thus, Man is characterized by two **dominants – the instinct of self-preservation and self-esteem**. All motivations are based on these two facts, but only one is priority. For some people the last word belongs to the fear of death, for others the decisive word is their ambition. Some are ready to sacrifice life for the sake of honor, others – to sacrifice honor for the sake of life. Logic in the situation of choice does not matter. Man who regards honor as the supreme value, having found himself in the situation of choice, has to either die with honor, or determine a new value for himself and continue to live, having lost honor. There is no third.

But what was Man like in the foreseeable historical time and why has he become exactly what he is in today's realities? **MAN HAS BEEN TURNED INTO AN INSTRUMENT**, into something that could only **be used for someone's purpose, that is, for the sake of anything or anyone, but not for the sake of Man himself**. And before "going deep" into the history, in order to understand why exactly that way the events had developed that become available to us today, why the same events had been concealed from us and distorted exactly the way as we had taken them, – first of all, it is necessary to understand that man was the "experimental mass", **THE BIOLOGICAL MATERIAL OF THE PLANETARY EXPERIMENT** for the old Subsystem, which had previously applied it in all programmed processes against his will and awareness of this fact, allowing only to destroy one another and see the basis of society's life only in the material production. Man was considered by the category of price – no more that that. So that we could, at a new level of understanding, at least somehow define the meaning of human life today, we have to fundamentally change the value orientation of Mankind, and lay at the basis of it a new value strategy: "The transition from People of Price – to Man of Values". Moreover, it will become possible when we realize that the very concept of work as a slavish application of forces has always been slyly hidden from us, forcing us to forget about joyful labor, the labor of searching and creating for good. **People of Price** – is the embodiment of the archaic, naively self-centered within the personality, a peculiarly pronounced consciousness of its

significance and an exaggerated opinion of oneself. The price for them is everything, even the goal in life. This is the most important characteristic of everything in the world, the world for such people consists only of material things, for, apparently, the only living, irreplaceable and priceless in the universe for them is their own self. **A Man of Values** is what everyone has to become, Man of **THE TRUE MIND, HAVING ANOTHER BRAIN and a higher level of cognition**. The goal in the implementation of this value strategy is a harmonious coincidence and a complete harmonious goal orientation of the value stereotypes of Man as a personality with the value ideal of Mankind as a single structure of social organization, whatever flowery and pathetic it could sound.

The main difference between Man and other kinds of life is, of course, not the body. The main thing is free will, the ability to make one's reasonable choice. **I do as I want to, and therefore I am a Man**. My decisions do not depend on the external circumstances, but on something inner, something that I do not yet understand, but strive for this understanding. The state of freedom or lack of freedom is an inner state. Man is a synonym of freedom. **The more I am free, the more I am a Man**. And vice versa – without freedom there is no Man. Absolutely not free Man is no longer a personality. He turns into an animal subordinated to instincts. This is what they tried to do in order to achieve the ultimate goal in the framework of the old Control System.

The most extreme variant of lack of freedom is manifested not when the body is shackled. Extreme lack of freedom comes when **CONSCIOUSNESS IS CONSTRAINED**. I will illustrate this idea with the example of a small story about the bear who lived at the zoo in a tiny cage. He walked, making two steps forward and two back. Then he was transferred to a large enclosure, but he continued to do the same two steps forward and two back, because the **cage "was" in his head**. The not-free man is the one who "was built" a cage in his head. He becomes an instrument in the hands of others. He is dependent on **other's** will and **other's** freedom. It turns out, the more inner freedom, the more of man and less of animal. And no instinct, not even an instinct of self-preservation, is a decisive argument. Absolutely free Man does not know half-tones, does not know compromises. He is a completely closed system, he is completely independent, and if this is impossible, he dies. But he dies free, choosing himself, and not by order of fear or passion. Even the fear of death can not change the actions of the free man, because he is free from the power of fear. He is above fear. He is the master of fear, and not its slave. An illustration of what has been said can be

"passing away" of Niolai Levashov, Alexander Khatybov, Sergei Danilov and many others.

Remember how beautiful it sounded: **"Man must have freedom to determine his own destiny"**. From today's point of view of many people, "the state exists only in order to protect Man from violence of other people or groups and expand the scope of individual freedom." However, with the unsuccessfully played scenario of the so-called "liberal democracy", Russia has not yet gained the sobering state. And millions of people have already understood and observed it, unlike the situation some 20 years ago, for example.

If the supreme Man is free Man, then the highest form of self-esteem is a claim to the title of a free Man. This is all- important for understanding of those who aspire to get to the Bath. Low self-esteem turns Man into an intelligent animal, completely in the power of instincts and desires. Nothing prevents an animal from satisfying, for example, the feeling of hunger, eating along with the dogs in the garbage dump. People become homeless not because of life circumstances, but because of zero self-esteem. They are not ashamed to do what they are doing, because they do not value themselves. But it's not their fault.

I'd like to emphasize that **AT EACH STAGE OF DEVELOPMENT** people were dictated a certain set of **programmed "needs"** in relation to the place and purposes. Moreover, the growth of people's "needs" in general is a programmed controlled process – as it was, it remains to this day. This



was envisaged by the ongoing control program implemented through people. Pay close attention to this and then a lot of the events around you will be able to see at a different angle. If the growth of needs had not been guided in line with the program, then the entire population of the Earth at the present time would have existed at the same level of development as the present few tribal savages in the equatorial belt. Each tribe, conforming to climatic features, would have satisfied its needs at the

level of "natural instincts" and would not have been worried about crises and other headaches. This is the answer to the numerous unsolvable scientific problems related to these tribes, which even today can not answer – why in the 21st century people are still going round "with their pants off". They are switched off the controlled process of "needs" formation by their Brain functions, so their evolution process was stopped in general. And they are preserved only for the purposes of strain¹⁵ comparison in the development process control of the particular Brain genotype.

Every Man wants to be free in his actions, free to do as he wants to, and not as circumstances made him do. Any Man wants to be a personality living by principles, but life and all of history perspective, if we look at it from our point of knowledge, which those who are ready with the "Broom for the Bath" aspire to, made their own amendments. Such a state brought about a passive and parasitic function, more often on the verge of a defective verdict – to be used. Different instincts, including an instinct of self-preservation, hold sway over man. Only individuals can defend their freedom. The bulk becomes the slaves of instincts. On this fact, the whole social hierarchy was built.

From the moment of birth Man, existing in a particular social group, analyzes everything that is happening and seeks to guide it. An infant manipulates maternal tenderness and fatherly love in his quest for a more comfortable existence. Growing up, the child is faced with the fact that he is guided, too, for example, with the help of desired delicacies or toys – the relationship becomes more complicated, and the analytical work of the maturing Man is getting more complicated, it begins to include more and more unobvious and implicit aspects of being. From vagaries for refusing to get the required toy, Man, studying the surrounding reality, goes on to assess the ambiguity of sexual relations in which the voiced "no" is nearly always "yes". But even this is the limit for many – which is achievable somewhere near the retirement age. Most of the reality phenomena remain beyond the bounds of comprehension and are perceived as occasional whims of fate, and man remains a passive filling, not only having no opportunities for meaningful actions, but also not striving for such. Now the opportunities are returned, but the unwillingness to strive for anything in unconscious or conscious forms in automaticity remains, minimizing the comprehension. However, reading all this and even more so when planning a trip to take the

¹⁵ The strain (from Stamm, literally "trunk", "genus") is a pure culture (in this case a brain) or a cell culture isolated at a certain time and place.

Bath – there is a chance to gain the will for knowledge, and with the knowledge there will come out sensible actions, eliminating the humiliating human role to be a used one.

2.3. Understanding and thinking over

Today, the overwhelming majority of people are not ready for true freedom due to their Brain state and level of its development. They understand freedom and perceive it as freedom from freedom. They take freedom for some kind of protest organized by someone which opposes any power and government in general. All protesters have one thing in common – they protest against something they have not developed in themselves or have not studied. This is all because of their feeble-mindedness and the lack of an elementary value-integrative preparedness of an individual in relation to the society. Mainly this concerns the so-called liberal democrats, who objectively appeared in the program processes to "create" the "golden billion". But ***freedom can not be for oneself or for someone else, it is either for everyone, or for no one.*** Freedom is unquestionable for Mankind as a social instrument of the future, but to such true freedom the most serious way is to go regarding Man's re-creation. So, so far, we just dream intelligently in silence about freedom. Because when we are dreaming, we are real. But it does not mean that we do not have to try to understand what has been said and to comprehend it, because understanding is intellectual comprehension of the accumulated knowledge bringing to awareness.

The above said is enough to understand: masses come into motion depending on their Brain perception of the transmitted information that is coming from the New, native Control System today. But, all the same, the reference points in this will still be **PEOPLE, WHO REALIZING THE ONGOING EVENTS**, are seeking for a way to new knowledge, having rejected all the prejudices on this way imposed on them in the historical past. Once realizing that their highest value is freedom, ***then the primary driver of human history*** is the will for freedom. If you want to be free, be free. Nobody is able to prohibit this. If there are some interfering circumstances you are afraid of, overcome them. If you are not able – then you do what you do not want to, but what you are ordered by your fear, which you have not overcome yet. You are a slave, not a free one, because it is

impossible to order anything to a free Man. **"Man without strength of mind is like a destroyed town with no walls" (Pr. 25, 28).**

Of course, I do want the glorious past of Russia and the history of people who have made this glorious past to provide their comfortable present and bright future, but it has never happened in the history of any country of the world. And Russia will not have it. What is Russia going to? A worthy present, making it possible to save the country and people, is a material embodiment of the theoretical project of the future. There can be no practice of the present day without scientific research of the future and its theoretical designing – this is the basic global idea.

In place of all the multifaceted, now unrelated to the reality diversified societies, there comes Humanity as a single structure of social organization. We will have to build Humanity with a re-created Man. **This is the principal key – a re-created Man.** The "construction site" is ready for work, the building materials are ready to be used. The core of the Ideology of the Conceptual Power is manifested, the Spirit has gained the states of readiness for the implementation of the New Program Processes.

And what is the Conceptual power in our understanding today? The term "conceptual power" has two interrelated meanings. **In its first meaning**, it is the power of people capable of:

- exposing problems and setting goals for their solving;
- developing a concept for achieving the goals;
- introducing the concept into the process of the society's life control.

The main thing is that the concept will express not the declared and ostentatious, but the real morality of the candidates and bearers of the conceptual power. The Conceptual power is autocratic in nature because:

- it is impossible to forbid people to think and act in life according to their intelligent will and their abilities;
- and the intelligent and expedient activity of just one Man can make an impact on the further course of events on a global scale for centuries and millennia.

The above is true even if the individual came to life as a "simple man", on whose individual opinion and will, according to the majority, does not depend the state politics and the history of mankind (although the examples of Christ, Muhammad and many others indicate the opposite).

The Conceptual power implies both the ability of Man to realize conceptual power in the above sense, and the realization of this ability in life.

The term "the conceptual power", in its second meaning, is the power over the society of the concept itself as a collection of ideas expressing the goals of society's life, ways and means of achieving them, the bearers of which (both consciously and unconsciously) is the society itself, regardless of whether : there are conceptually powerful people in the society, what their share is in its composition and what concepts they develop and support; or the society is composed of conceptually powerless hostages of certain concepts.

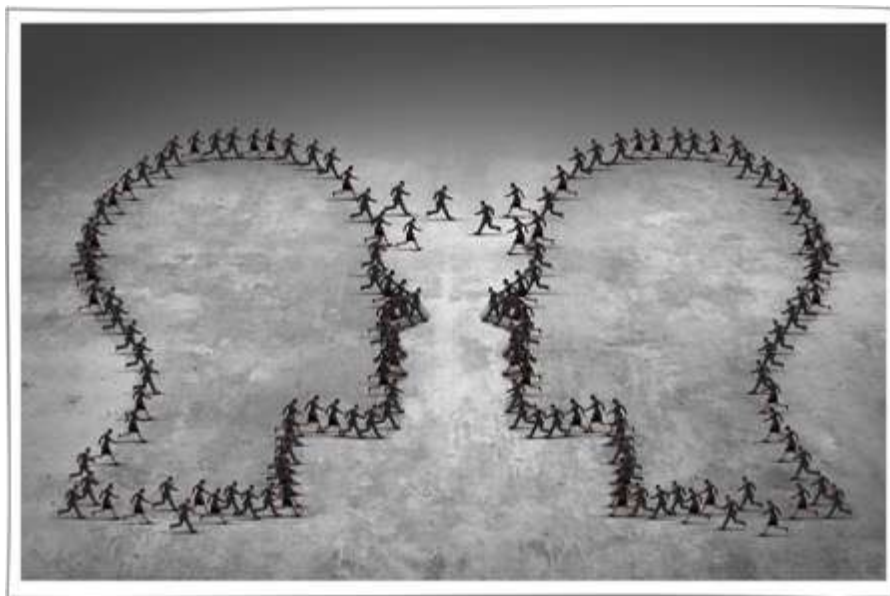

Against this background, Mankind **IS A SPECIAL PROGRAMMED STATE** of the Earth Model. Such a state the Earth had had only before the intervention. Now this state will be restored during the transition period in the framework of the new Program. All the readers probably understand that nowadays the human problem is the core of the problems of Russia and all other states in the world. The state in relations with the ongoing processes, including globalization¹⁶, **IS PRESENTED EXACTLY AND ONLY BY MAN** who either uses the global changes in the world in his own interests, or globalization uses him as its victim. It is Man who is either ahead of globalization, foreseeing the future, or globalization is ahead of Man, destroying him in the past. But all this is only a consequence of the control processes of everything and everyone, the processes that are realized through specific people, specific masses of people and specific "planned events", if I can put it so, which rather to be called "target vectors". In this connection,

¹⁶ **Globalization** is the process of worldwide economic, political, and religious integration and unification

the problem arises – the human capital¹⁷ production in the necessary quantity and up-to-date quality, and, of course, depending on the specific Brain genotype. The rest will be done by the people themselves, if they are sufficiently prepared. Well, if they go through "washing" in the Bath with using the "Broom", then success is guaranteed, which, in fact, I do not doubt about.

Trying to prove that there is no human capital adequate to globalization in Russia, and, worst of all, no one, and not only in Russia, knows the parameters of the available human capital and nobody wants to know it, is quite objective. And it is objective within the framework of exactly those programs in the Control System, some of which create (do everything to accelerate this process) this human capital, and other programs that "block" the Brain of the so-called "rulers", do everything possible for them so that they are not able to understand anything of the events taking place. That's why they "do not want to know..." Meanwhile, the parameters of human capital in a particular territory (country) today are more important than the parameters of financial capital, and more objective in measuring, assessing and accounting than financial capital, which is constantly talked about at all possible and impossible sources and sites. There is a simple explanation to this – **MAN IS THE BEARER OF THE WORLD PICTURE**, lifestyle, life position and world outlook, which can be more or less adequate to what is happening against the backdrop of the imposed globalization. Today's state, or rather, specific individuals with a specific Brain genotype, personifying the state as a created historical mechanism to support them, but in auto-motor-like way, "produce" human capital with the distant past world picture, trying to find support on exactly what it was then... in HisTory. And, naturally, such people can not be successfully adapted to the present by the current projects of the future. I am more than sure that if there is no "human capital" that has been accumulated in people, which unites these people in the quest for knowledge and development going ahead of the current projects of the future, there will not be this country, despite the incalculable natural resources, vast expanses and plenty of other things. But I also know that this will never happen both for objective reasons, which are already obvious to us, observers and participants, and, of course, for many subjective reasons that manifest themselves in the development of the objectively happening events. The state of human capital and society is

¹⁷ **Human capital** is a set of knowledge, skills, used to meet the diverse needs of man and society as a whole.

the subject of a real and deep thinking study today by those who, despite everything, took the Spade of knowledge and moved forward.

2.4. Deserved and recognized

At one time, materials and instruments of research with limited access were provided in the established format for the relevant current time and at an appropriate level, which are now strategically important for Russia during the transition to the terms of the new Program. They are not yet open to publication, but some points related to understanding (of those who, of course, want to understand) what is going on, and taking into account the prospects that open up to each Man, even those who live on the "autopilot" today, ***I will tell you – within the limits of the "allowed"***. There are many who are now well aware of the help that the "SvetL" Programs provide in all this, and specifically in the issues of cognition. Moreover, I note that it is through strategic functions that **THE QUANTITATIVE AND QUALITATIVE** regulation of the entire planet population **WILL BE DETERMINED**. By the way, it is important to know, ***because there will be neither surplus nor quantitative shortage of Humanity***. These are questions not of a social, but of a functional nature, i.e. related to the mission and active participation of Man in the Earth general processes – a person becomes Man. Only in Russia, there is sufficiency of such material, which can be given the right form – these are people who are able to become Man. Only Russia is able to feel most of all the stinking domination of the Old System's barbarians. And today more and more ordinary people can notice it. But this notion of the old Control system as ordinary people – can not exist any more. Each Man is a Personality and so complex in all his "parameters" and aspects that today's Brain of very few is able to comprehend it in full. Not Mankind (as a social union) has got such a name because of and from Man, but Man has gained this high mission, because He is an important fragment of Mankind as a state of the common model, possessing extensive creative functions of high level and order. The highest recognized merit of every Man, as the primary principle in the social organization, is **THE RIGHT** recognized by Mankind **TO BE IN THE STRUCTURE** of the Non-structural power. This is a well-deserved and recognized social position, i.e. voluntary consent of the rest members of the social organization with such a deserved social position of a personality. Is it difficult to understand and accept it today? Yes, it is difficult, but the

processes in this direction are developing very intensively. There are many people who say: "No, nothing has changed around us for decades..." This is not so, take my word for it for the time being, – for the last two years so much has been done that it is difficult to express the significance of all this. At least this leap – ***it replaced the last four centuries in its movement forward to knowledge. 400 years within two years!*** And this is done with the participation of people and through people. Sometimes I think – maybe it would be better to "slow down" a little... Now we have to start to form the realization of elementary things that need to be protected. What to protect? To protect the control processes of the elements of support both of the Earth, and on the Earth. But for this, people still have to get to know a lot, and mainly, at an "accelerated" pace. And will the Brain withstand this rate – will it survive? I am sure that most people living in our vast lands (in the broadest sense of the word) will survive. The striking fact against this background is that state political and economic decisions are based on the ideas about the quality of human capital in Russia, taken from literature and journalism, like "Russia can not be comprehended with one's mind..." There is **NO SCIENTIFIC DATA ON THE LEVEL OF DEVELOPMENT** of attention, memory, intellect, will, speech of Russian citizens, and no one sets a task to collect them. Because there is no one to collect. And there is no understanding what to collect it for. And they should be just as scientific and objective, at least within the framework of our current understanding, as data on the height, weight of the body, the volume of the lungs of citizens of Russia. The systems of value, including human capital, in the broadest sense of the word, are formed and transformed in the historical development of society as programmed processes guided from outside. It is in this situation the hidden influence of programmed values is revealed, given from outside and manifested in the being of people, on the establishment of the corresponding to norm order in society through the construction of a special design of statehood and authority that always strictly corresponds to the current Target Vector of the actions performed by the people which brought to the programmed actions. So it was and so it is now, but already in the more intensive use of people (human capital). Under way is **THE MOST SERIOUS AUDIT OF HUMAN CAPITAL** not only in Russia and with the involvement of people through whom this is realized as information, but also without their participation with all the ensuing consequences. For example, through natural disasters and changes in the life support system of people, so-called epidemics and diseases, slowing or increasing mortality in specific areas, demography, reproduction and much more. Is it possible to

"compile" a strategic forecast of global changes in the world, create some kind of theory and methodology for the state of society and citizens of Russia and the world? In my opinion, it is possible and necessary. For a true understanding of the ongoing events, relying at least on what has become available and public in recent years – the information that should be drawn from the books by *N. Levashov, A. Khatybov*, which I have repeatedly mentioned and go on talking about, the materials of the **"Center for Preventive Strategies" (Scientific Research Institute of CPS), "RNTO" and, especially, "Foundations of Mankind Formation"** (public parts). This is quite enough at the current stage, provided, of course, the interest and purposefulness of the people themselves. We just heard from everywhere that Russia de facto dropped out of the number of countries whose opinion is decisive; the Russian economy is a very small part of the world economy; Russian high technologies are an insignificant part of the world scientific and technical progress; by population, Russia has gone back to the seventh place, and on the quality of human potential, annually counted by the UN, takes the 65th place in the world (Human Development Index (HDI)). So, answer to yourself – why the 65th place and why there is nobody to work in the country. Answer to yourself, why are you always "told" that attempts to activate the domestic economy fail because of a shortage of labor resources, the lack of sufficient motivation for their citizens to work and the inability to work at the present level, which can create motivation? And may it be all wrong? Probably, it is more important to determine not in the sphere of assessing the material resource base, where the forecasts of specialists from the past were traditionally started and made. This time it is more important to clarify the current authority – administrative apparatus' state and organizational resource, which will have to realize all this, of course, directly through the created human capital, in which for the first time in the entire previous history of all societies the question of social justice is already being solved: providing of goods, services and social recognition according to one's intellect, and not for money or illegally gained power. Consciously aware of the importance of his personal mission, Man will be differently targeted – spiritually and mentally. He will be striving for the results and quality of his work, gaining by this self-controlled conscientiousness in all his deeds and actions. This is exactly true harmony of Man and Mankind. Here, readers, is the principal goal, without which there can not be any fundamental changes.

For "the tops" and "the bottoms" in Russia, and not only in Russia – there is different patriotism, different motivation, different opportunities,

and this is not taken into account. It is exactly in today's human default that all problems of the country are held up, and the so called "leadership of domestic politics and business" does not know their people and their opportunities. "The tops" know how much money and what kind of money they have, but do not know how many people and what kind of people are in the country, and how many they need to fit into the globalization to save the country. What qualities of human capital are necessary for the future, how to form these qualities – is the applied value of this work. But it is objective and can not be another way. The program "to create the golden million" has failed – with all the ensuing consequences. But the process of recreating Man has already begun. No one can stop it. This process is not instantaneous and, basically, can not be initiated by Man. The Recreated Man **WITH A RESTORED BRAIN OF HIGH OCTAVES** will have quite different attitude to the fulfillment of his true functions (finally – sensibly). The fulfillment of his mission will be supported by the changed environmental conditions as a whole and the modified programmed processes of the restored true (native) Complexes and Control Systems. ***Transition, or rather, restoration of Man's Brain*** at a significantly higher level, changing the way and form of being, gaining an opportunity in the freedom of the Mind and actions to perform his functions, a completely different, not animal-like level of awareness of his mission on the Earth will qualitatively change the attitude to each other. The functions of territorial and any other aggression are already being removed from the Brain today. The process is under way that, against the backdrop of a multifaceted «clearing up" the Brain from debris, makes it impossible the conditions and possibilities for restoring an individual's unlimited selfishness. The process of substantial prolongation of life of Man is in progress, but only in case of gaining new qualities of the Brain and new properties. And all this requires taking the Bath, using the Broom, too... It will not be otherwise. And the slogan that was imposed on us for centuries so that we could not understand the true meaning of the events under way – ***"Jews are to blame for everything"***, does not work any longer, even when the Jews themselves say it.

Each recreated Man (and there are such) is especially valuable, unique, has a specific active function in the overall performance of the programmed processes of the new, because it is mainly through them that the new can be implemented. The level of new knowledge will allow Man to gain a certain life universality and his active position in the new social structure, including, initiative voluntary, his full efficiency through labor for the sake of others. We have been deceived for many years, destroyed, there has been committed

an outrage against our faith, our attempts to know the truth. We were just buried in the ground in every possible way, the young generation was corrupted. And quite recently they, those who have got a false idea of being "rulers", thought that we were dead. And it turned out that **WE WERE THE SEED OF THE FUTURE SHOOTS**. And no longer lonely sprouts of the truth, but a vast field, which is expanding every day, covered with green shoots. Soon, there will be blossoming, and its scent might make some heads go round. But it's important not to lose them, but remember that flowers are just ovaries for a generous harvest. We all need the harvest. And we will bring this harvest to our house. In fact, unlike the well-known "Our Home is RUSSIA" – Russia is our home, in which we have to do spring clean before we bring our harvest. This spring clean should preferably be done by our Broom, and after that – running to the Bath. I hope the reader has no doubts about it.

2.5. One should not multiply the existing...

"...the professor beckoned to both of them to approach and when they leaned over to him, whispered":

– Keep in mind, Jesus existed.

"You see, Professor," replied Berlioz with a forced smile, "we respect your great knowledge, but we have another point of view on this matter.

– But there is no need in any points of view! – replied the strange professor, "he just existed, and that's all".

– "But there must be some kind of proof..." Berlioz began.

"And no proof is required," the professor replied and he went on in a low voice, and his accent disappeared for some reason: "Everything is simple: in a white cloak..."

"With a white cloak on, with blood-color lining, shuffling the cavalry stet, early in the morning of the fourteenth day of the spring

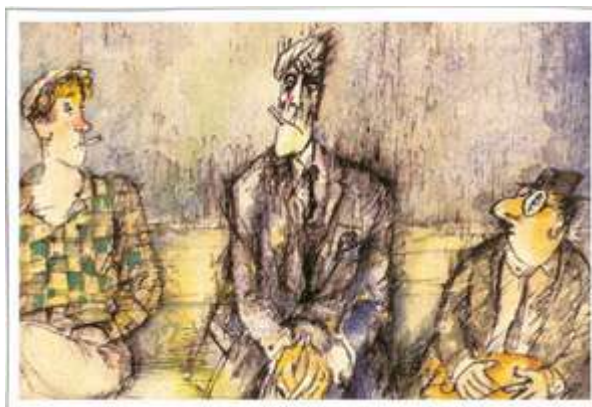

month of Nisan, the procurator of Judea, Pontius Pilate, entered the covered colonnade between the two wings of the palace of the great Herod..."¹⁸

Do not be absolutely sure about anything, never interfere with the process of thinking and do not be afraid to be eccentric in your views, because any opinion accepted today was once eccentric. Do not ask God for welfare, but if you ask and you can not be without God, – then ask for some wits, skill, imagination, creativity, joyful labor. Otherwise, you will go on to "pay homage" to the "Black Square" by Malevich¹⁹ **as the greatest canvas of mankind** and hang it in the living room and in the bedroom. But "Bears in a Pine Forest" and "Three Warriors" nailed in pubs and teahouses in order to tell trivial anecdotes under delirious drunken intoxication about their own life and the Motherland, taking these pictures for nothing.

It is known that Malevich had four "Black Square" pictures – the first one is kept in the Tretyakov Art Gallery, one copy is in the Russian Museum and one in the Hermitage. However, Kazimir Malevich was not the only one, or even the first one, who was fascinated by this simple and powerful form of expression of thoughts and emotions. The first known to science "Black Square" appeared **in the beginning of the XVII century. Robert Fludd, the English mystic philosopher and astrologer**, portrayed a black square against a black background to illustrate the concepts of macro and microcosm in his treatise **"Utriusque cosmi maioris scilicet et minoris Metaphysica, physica atque technical Historia" (1617).**

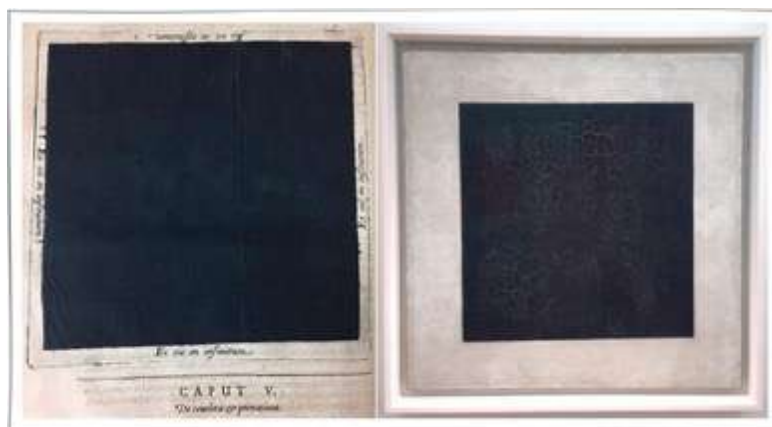

**Robert Fludd, "The Great Darkness" (1617)
and K. Malevich "The Black Square" (1929)**

¹⁸ M.A. Bulgakov – "Master and Margarita".

¹⁹ **Kazimir Severinovich Malevich** – (Kazimir Severinovich Malevich was born on February 23, 1879 in Kiev, died 15.05.- Leningrad) is a Soviet avant-gardism artist, teacher, art theorist, philosopher. The founder of Suprematism – one of the earliest manifestations of abstract art (Suprematism, Kubofotourism, Cubism, etc.) of modern times.

With these pictures, by and large, there are plenty of versions: – there was also the picture "The Battle of Negroes in the Dark Cave Deep in the Night" by Alfons Alle – he painted it 33 years before the first "square" by Malevich (in 1882). And under Malevich's "black square" there were found two more "squares", one of which was signed "The Battle of Negroes in the Dark Cave." There was also Paul Bilhod (also 1882 and, as they say, before Alle) – "Night fight of Negroes in the basement". In 1854 – "Dusk History of Russia" by Gustave Dore. But what it was like in reality – it is hardly possible to find out. And is there any need? The subject was popular, either in absentee fun, or philosophical dispute there were many involved, and most likely not only the mentioned authors, so the chain of events itself is indicative, which has now led to an indistinct, but unanimous veneration of "the Black Square", not even as a picture or a pictorial canvas, but as a symbol of "unattainability in cognition" of all those who does not accept or understand something in this matter. All amicably try to admire because it is supposed to be admired – it is not clear what exactly for, but it's not for us to decide this. It is said – great, so it is – great.

The entire development of our world looks like a complex intertwining of various opposite principles and contradictory tendencies against the backdrop of the continuous action of random factors destroying stable structures and creating the prerequisites for the emergence of new ones. But the contradictory tendencies and the intertwining of opposing principles that develop in our head when we want to know something is the reality of today that was created purposefully so that we perceived everything in the way it was imposed on us both in historical aspects , which were basically just invented for the sake of specific goals, and in the current understanding of the present-day world.

How much new we can discover if we look closely at the ordinary, or, say, think it over what we know well. Why do people take on trust everything told to them with a significant face, and perceive what is said as the truth only because the interlocutor looks respectable, although he hides a sly grin in his dense beard? I will try to reproduce some scheme that could be conventionally called "a sketch of trends in the change vision of the historic planetary picture" drawn by a great number of authors, beginning with the most "ancient" times of the mankind development and finishing with our days, as I see it. Perhaps, there are many who will disagree with it: historians will find one group of shortcomings, political scientists – another, specialists in the problems of civilizations will probably notice inadequate detail analysis of the current stage development peculiarities, etc. It is unlikely that

my excursus in this book and the previous ones will cause serious objections, which is based on the fact that the entire history and the process of humanity development for the **last 18 thousand** years are based on the achievement of the initially set tasks, related to the **DEVELOPMENT OF THE BRAIN GENOTYPES OF PEOPLE** for their further planned use, which has already been much written about. Of course, such local objections and inconsistencies in understanding are inevitable when people try to bring together a certain multitude of very different considerations. At the same time, it is unlikely that the basic conclusion to which I am leading the reader is unlikely to be objected to, using the information I own and which I have no doubt about, because it is derived from the works of people, or more precisely – of Humans and in communication with these Humans who substantiated them not only theoretically but practically, in their real deeds. What is happening is to happen! All the concepts that become known to us are introduced by Man who should become a researcher when trying to describe reality and this is his objective interpretation, and the correctness or incorrectness in reasoning is just the language adapted to describe mental activity. When interpreting what is happening, you can do without it – let us recall the principle of the "**Occam's blade**"²⁰. And, of course, do not postpone anything "for tomorrow", because if today – there is no time, tomorrow – there is no strength, and the day after tomorrow, there may be no you.

* * *

So, Jews... If you try to put together everything that is written about them, then you might fail doing it. But this is not the point. The point is that until recently all this – written, told, shown, etc., tended to prove to the whole world "God's selection" of this "people", their unordinary qualities in everything and "total superiority" over others. But "suddenly", most recently, within the current time, there occurred a sudden change – a change in presenting and providing information about everything related to this people. Information on the history of Jewry and Jews as a certain people began to appear, breaking through and spreading rapidly: about everything connected with the role of Jews in the history and their influence on the development of certain historical processes that, under their direct "guidance" have brought to today's reality.

²⁰ "**Occam's razor (blade)**" is a methodological principle, named after the English Franciscan monk, philosopher-nominalist **William Occam**. In a simplified form, it reads: "**One should not multiply the existing without necessity.**"



This information is deafeningly interesting in the attempts of understanding and cognizing – how all this happened and why it was so carefully hidden from people. One can write plenty of books, but I will not do it, because today there are a lot of sources on this subject, written both truthfully and slyly, distorting and juggling with facts that have already become known – a sea of information, the purpose of which is not to hide it, as I have already mentioned, but **to drown in it all those who decided make out and understand**. Do not wait any hints, reader.. Take the Broom of knowledge and start digging yourself, reasoning and comprehending the dug-up information. However, "plunging myself" into this subject deep enough, in my opinion, I can say that most profound, capacious and substantiated (from all points of view) are such researchers and writers as **R. Klyuchnik**, in his books, **G. Panteleev** in his well-known short pieces, **A. Tyunyaev** in his articles, **V. Afanastyev** in his books and, especially, in the book "**Russian writers about Jews**", **T. Volkova** in her publications and, of course, others – have revealed, both historical and modern moments related directly to this subject. But I made up my mind to dedicate part of the chapter to this question after reading many of the short pieces by **G. Panteleyev**. I believe that today this is one of the few true sources describing the events related to those historical processes with direct participation of the so-called Jews and all those who were somehow connected with them. Of course, one can argue with the above, find some inconsistencies in the presented documents, but all this is fading against the backdrop of the information that this person made public and which, with his permission, I partially use in this book. But neither he nor those whom I have listed and recommended to you, readers, do not answer the basic question – **WHY IT WAS EXACTLY THAT WAY**, and under no

circumstances (even if you fantasize and change some of the historical personalities) **COULD BE NO OTHERWISE** Why people in those historical processes, events and actions acted that way, agreed with what was presented to them (no matter what point of view and who by), although, looking at those events with our present-day eyes (after learning the truth about what was happening), we understand that exactly that way could not have been taken place. But it had been that way, even beyond all logic. Where can we find an answer to these questions? In the writings of **N. Morozov, N. Levashov, A. Khatybov** and, of course, in the **"Foundations of Mankind Formation"**, which, although partially, have already become public and available.

2.6. With broad strokes

What is going to be said further may surprise the reader with the simplicity and logic of the presentation, which I "picked up" from the epic²¹ that came to my eyes just "accidentally", as it happens when you start seeking for the material necessary for certain purposes. It tells about the roots of Judaism, but not the ancient one, derived from Christianity (like all world religions), but the one that was formed in the **17th century**, after disintegration of the great empire of the Slavs – **the Great Tartary**.

So, in 1453, Byzantium or Second Rome fell. The Center of Religious and Public Administration finally moved to the Volga, to Master Great Novgorod – the totality of the towns of the Golden Ring of Russia with its capital in Yaroslavl (Yaroslavl Court of MGN). There arises the Tsar, or Russian Rome of the Great Russ-Horde, although Byzantium or Kievan Russ was also under the Slavs. Just after the fall of Byzantium, there remained one capital in the world – Master Great Novgorod (MGN). There were many reasons for this. They can be found not only in G. Panteleev's but also in other researchers of this subject, in particular, in N. Morozov's, works and A. Fomenko and G. Nosovsky in their "New Chronology".²²

²¹ **G.V. Panteleev** – "The era of mercy."

²² **The new chronology of Fomenko-Nosovsky** is a scientific theory based on research of numerical and qualitative characteristics of historical messages of narrative and astronomical nature. This theory is based on mathematical methods and has two main results: a conclusion has been drawn about the fundamental mistakes of traditional chronology; an alternative reconstruction of world history and chronology is constructed. A number of predominantly humanitarian academics, without any serious evidence and demonstratively evading scientific discussion, declared the mathematical theory of Fomenko

By the principle known in Kievan Russ, the kings of Great Russia began to create the same financial institutions that worked perfectly in Byzantium. More precisely, they just transferred the subordination to the then "Central Bank," changing the direction of the capital flow, but leaving everything as it was, including bank employees. In ancient times clannishness already existed. So, the smith passed his skill to his son, and the latter to his grandson. There were whole dynasties. Look at Tula. There are still whole streets, where people of one occupation settled. There are quite a few families whose names are known to us from the annals. Men were



engaged in the work of ancestors, storing the knowledge of craftsmen, and wives were taken from other classes. The same was also in the financial sphere.

We will not consider appearance of money in the world of people. This can be read in other books and works. We will not look into the Byzantine financial system – we are more interested in the moment when modern Judaism appeared, which turned into Zionism.

It is quite clear that ***the first bankers were not owners of money***. They themselves and their property were considered the property of the state. And while this state was strong the situation was exactly such.

Read attentively **A. Pushkin's play "The Miserly Knight"**, which reflected the real state of affairs in the early Middle Ages, when the empire was stronger than ever. The situation, when a medieval knight requires money from a Jew, entered the literary classics. ***The knight is just convinced that the money of a Jew is his, knight's money***. But how could it be otherwise? It was he the basis of the state's defense: here and now, on the spot! Tell me, have you ever read in any chronicle, when a warrior took money from an artisan? No. On the contrary, he paid such people. But **HE DID DEMAND MONEY FROM A JEW**.

So there comes a knight to a Jew for getting "monetary allowance", and a Jew in numerous legends assures "that there is no more money". And then

and Nosovskii pseudoscience, recognizing the scientific status only after the traditional chronology created by **philologist Joseph Scaliger** and **theologian Dionysius**. The foundation of the "New Chronology" was laid by **N.A. Morozov** – Russian scientists of the first half of the twentieth century. It was he who wrote the works, reinterpreting the chronology of ancient history up to the XIII century and prompted further studies in this direction. **N. A. Morozov** was the first scientist to apply natural scientific methods of research in historical science.

the knight begins to shake his accountant, the chief tax officer, the treasurer and other financial small fry by the collar. The most usual talk with the bookkeeper, who seeks to limit the delivery of cash, determined to the knight for imperial pay.

When the enormous Mongol empire came into being in the 14th century (not the Tatar-Mongols, it was Russ), which stood firmly on four continents, its creators, Russian-Horde khans, who had derived from the family of the Roman emperors, needed to regulate life in the Empire. ***For this purpose, the institutions of state power were established, including financial ones.*** They existed in Byzantium and they just were switched to the new control center, keeping the principles of its function, the financial class and the monetary system in the financial sphere. It was at the beginning of the 16th century that Judaism dominated this financial class.

If you look closely at the Torah and the Talmud, it is quite obvious that they are a kind of "Regulations on the chief (senior) accountants", incidentally, of the recent Soviet past, only reinforced by faith in God, who is thanked for the fact that he "slipped into their hands not so much labor-intensive work". Of course, all this is simplified for common understanding, but banking operations in the Torah and the Talmud are present in every line. Read it yourself – you will know a lot and make sure that the information is true. This class, due to the specifics of their activities to control the finances of the Empire, gradually gained the real power, **WHICH HAD BEEN OVERLOOKED BY THE TSARS-KHANS** of the Great Tartary. Thus, an ordinary clerk of the bank became a respected person. As an illustrative example, is a queue for a pension, where a simple cashier runs the lives of people who have great merits before the state. The cherished window to the cashier makes every rebel humble. Within any imperial guild-class, relations with God developed in relation to their professional activities. The smith asked for skill and worshiped Hephaestus the blacksmith, the merchant – created his "holy" Hermes, the warrior had as a defender god Mars. Everyone had their own patrons. Within one professional guild, a religious community was naturally formed, which was characteristic of only this caste. Today we can see it in the religions of India. That's how it was at the very beginning. So the second blinkers²³ were born (the first is the creation of a state), which made it possible to control people to this day. Naturally, the religion had its secrets, which were kept under seven seals,

²³ **Blinkers** – harness, covering the eyes of a horse (mule) for obedience and control.

because it was the knowledge of only this guild. Judaism is no exception. Expulsion of traders and money changers from the temple by Christ manifested in Judaism their attitude towards Jesus. And not only this. One of the conclusions is the following: present day Judaism arose as religion of the guild-financiers, inherited by the empire from Byzantium. In the Empire of Slavs, the principle of religious tolerance was active, and **NONE OF THE RELIGIONS WAS PURSUED**. Everything took place the way as it is today in India: with general Hinduism there are separate religions of caste-classes, among which the "caste of Harijan ("untouchables") is quite interesting. Let's leave the Horde Empire for a minute and turn to Byzantium. Who could the emperor entrust keeping and control the finances? Of course, a slave who is his property, as well as his family. Of course, the emperor fed this slave and his family, and fed well – but brought up in the understanding that money is his, the emperor's, and he, the slave, only counts it. What can restrain a person having absolutely no rights? Only family ties, that is, to pay him with the well-being of his family under a constant threat to separate them forever, and kill the slave himself. Was it a powerful argument for special devotion to the master? To achieve this, there required people having no rights at all and with the inherited state of slavery. And such people was found – they are the Wallachians, or the ancestors of Gypsies. Some of them were settled to finance, others to trade, and the rest – to transportation of goods. They were all slaves then. And now, who is what? Financiers are the Ashkenazi, or to be more precise, descendants of the first Byzantine financiers-slaves. Security guards are the Sephardians, that is, nomadic gypsies, who spent all their lives moving from place to place, delivering goods all over the world. The Jid are the traders who emerged with the onset of commodity-money relations. Thus, the untouchable sect got control over financial and economic flows, but it happened in the Slavic Empire. Since the Slavs did not know slavery, unlike the Byzantine rulers, at some point the entire system serving the empire became free or relatively free. So, the first financiers are slaves – without any rights, but well fed, frightened with the responsibility for their life and family. Let's name them financiers-Byzantines. The second financiers are a semi-free Horde class, getting a state salary for collecting taxes, finances accounting, their transportation, trade operations and so on.

Sephardians, or security guards were located in Spain – the extreme point of Eurasia. There comes a band of gypsies, has a rest and again goes on the road with the songs and the sound of the guitar. The people of the road are about the same as soldiers of the internal troops from the road convoy,

who are all traveling in a convict car. The Ashkenazi settled on the Rhine, where they **CREATE THE WORLD'S FIRST BANK AND BANK INTEREST** for the capital use. This idea inspires rulers who come from among the imperial nobility and rely on their ancient families. This is also a caste, which is partially consists of the warriors (princes and boyars). Jids appear in places of brisk trade. All these tribes have a common Judaism, but there are distinctive features for everyone. However, all of them, united by their common occupation – money, raise them into a cult of the deity, actually observing the power of commodity-money relations. This brings them to the idea that ***they are God's selected people***, and their god is somewhat different from what is accepted in the empire, since he so successfully opposes the god "ruling". And in general, giving them knowledge about money and the ability to handle it, he was much higher than all these chimeras of philanthropy and sincerity. He "brought them out of Egyptian slavery" and made them not slaves, but **NECESSARY PEOPLE IN THE EMPIRE OF SLAVS**. And this means that he will make them masters over those who until recently considered them slaves. That's what the Jews think. Internal ties in the class of Horde financiers, employers of the imperial monetary system, proved to be much stronger than, say, professional ties in the caste of the Horde warriors. This is not surprising, and now, if you pay attention – the information is transmitted most quickly through the banking line. This is the nature of the activity. Moreover, this class was separated from other professional structures. The reason is a commercial secret. ***This means that the rules in this organization should be under seven seals.*** Unlike other classes, permeated with various religions (in Russia they were tolerant to all), the financial system had its own rules, which were determined by the new Judaism, that is, the religion of the Horde financiers. ***If you want to work there – accept the Jewish faith, and as a brand to it – circumcision. Now you can not hide in the bath.*** Still, disgust for financial operations, and more important, the memory of the slavish origin of the Horde Jew, continued to persist among the rest of the empire people. The Jew remained untouchable, like their ancestors, Byzantine Jews.

The Jew had, and still have, religious differences. This accounts for the guilds represented in the financial sphere of the empire, about which is mentioned above. The Empire of the Slav was organized on the principle of federation. There were many kingdoms and rulers subordinated to the single center in Master Great Novgorod. The language of the state was Russian, Church Slavonic language. However, along with it, the Tatar and Turkic folk

language was widely used. **RUSS OF THAT TIME WAS BILINGUAL.** Russian people spoke two languages – Turkic (folk) and Russian, derived from the Church Slavonic (the language of the Holy Scripture and state clerical work). Subsequently, after the separation of Islam and Orthodoxy, ***the Muslim part of the population of Russ did not take alien the Arabic language by its pronunciation – the sacred language of Islam, and continued to speak Turkic.*** And among the Orthodox part of the population, already in the era of the Romanovs, the Turkic common language was gradually completely replaced by the Russian and was forgotten.

All subjects of the federation had certain functions. Some grazed the sheep and supplied their products, while others were only merchants and lived on it, and the third ones were production workers. A system of cooperation was established all over the world. However, everyone to a man paid a tax – a tithe for the empire army maintenance, or the Horde, which was present everywhere to maintain order and the will of the imperial center. The descendants of this army have survived to this day – these are our Cossacks.

Thus, all classes were tied to certain places of residence. Well, the metallurgist will not go to the steppe of the Ukraine to melt the ore. It just was not there yet, but the Donbass was not developed.

The imperial financial guild, unlike other guilds, did not need any special separate state. In a sense, it had it, and it was the whole empire from America to China.

If other states formed national structures and cultures, then the ***Jew did not have such an opportunity.*** They could be sent to work anywhere, because their specialty was applicable everywhere. ***Thus a cosmopolitan people appeared, completely unrelated to the place of residence, to the land of their ancestors, to the genus and place of birth.*** The change of names, religions and cultures is a normal state of affairs for the imperial treasurer. Today he is Ivan, tomorrow he is Jean, then he is John. Where he is sent, there he is named. These people, strangers to any society which treated them with contempt, could not be united either by the land, or their sovereign, or their culture. However, their religion made them cohesive, which was taken by the financier completely different from the opinion of the whole world. ***While everyone considered them inferior, the Jew were aware of being selected by God.*** And this was contributed by finance, trade, money at interest. Their

own language was "invented" on the basis of the German dialect. ***It was called Yiddish.*** This is the language of accounting. ***As for Hebrew, this is a recent invention that appeared with the idea of statehood. There came into being their teachers of accounting – rabbis (the rabbi is just a teacher).***

2.7. The emperor's "Villeins"

In accordance with one of the decisions of the ***Nuremberg Seim of 1390, King Wenceslas*** ordered the Jew (it should not be forgotten that then, according to the legal concepts, they themselves and all their belongings were the property of the treasury of the Holy Roman Empire – Russ-Horde) to give out all securities and promissory notes which were in their hands. The Jew had to obey the government order – and they obeyed. However, a little later, after this financial turnover, the state of affairs turned out to be in the same situation as before. What did the decree of King Wenceslas say? Yes, of course, about remitting the debts and loans that the imperial warriors had borrowed. Fearing an armed uprising of soldiers, the king remitted his soldiers' debts. Note that the word Jew is written with a capital letter, that is, it is the question of the name of the Guild, and not of nationality. However, time passed and the soldiers again had debts. What happened next – the decision of the Diet is not reported, but it is not difficult to guess. In view of the specifics of their activities (control over the Empire money), the Jewish social class gained power, which had not been envisaged by the founders of the Great Empire. The Jew began to get out of obedience and, ***having the means, to lure warriors to their side.*** This was noticed by the Catholic bishop on time, who called himself Pope. Being ready to fight against the imperial yoke, he had desired for a long time to come to power in Europe, because he was a descendant of the Latin patriarchs of Byzantium, expelled from ***Tsar-grad-Yorosalemna on the Bosphorus in 1263.*** That's when the "project" of the third modern Judaism, the religion of European financiers, was conceived. The then tsars – khans of the Empire, apparently, did not realize on time the danger that threatened them. ***In the XVI – early XVII century, the Empire was disintegrated.*** After some time, **THE POWER OF MONEY “FLOURISHED” ON ITS WRECKAGES.** What happened during the Great Troubles (Reformation in Europe)? From the empire there began to break off pieces, immediately declared themselves "independent". The wars of the Reformation began, as

a result of which the well-known countries of Europe emerged. They were formed from the old Horde provinces, in which the rulers were changed urgently for the new ones, loyal to Pope. ***In Russia the Romanovs came to power, natives of western Russia, most likely from Pskov.*** However, the Jew were not so easily able to come to the present state of affairs. The persecution of the Jew in Western Europe began immediately after the collapse of the Great Tartary. In the Lutheran Chronograph of 1680, we read that in 1615 ***"the ancient commonwealth between the countries is restored: the Jew are ordered to leave the Formation"***. What is said in these words? That in 1615, right after the Time of Troubles, the Jew, deprived of rights, had to be expelled from Europe, which was called "formation", or association. And this unification was only in the empire of the Slav, that is, immediately after the Time of Troubles a temporary restoration of the past took place, but on the lands that rebelled against the authority of the Master Great Novgorod. Where do you think the European rulers put these Jews? That's right, they were sent to the ghetto. In this ghetto, the Jew were for a certain time, while wars were going on in the West. But ***there came peace, and the Jew were again required by the states***, and first of all, by the Vatican. The Pope was more cunning than the tsar-khans. He made conditions for the flourishing of their religion and finally took off the slave brand from these guilders. Thus there appeared ***the strongest link of Juda Christianity, or Catholicism.*** For the first time, the largest world ruler began to defend the Jew at the state level. ***It was with the Pope initiative that the Jew became "God-selected" people at the legislative level,*** and **FOR THEM IT WAS INVENTED THE ENTIRE "ANCIENT" HISTORY**. Realizing what kind of connections they had around the world, the Pope decided to take advantage of them. The money came to be widely used, skillfully directed by "experts" who had gone through a difficult path from a slave to world-class financiers. How was it happening? Well, about the same as it is going on now.

After the Empire's disintegration in its separate fragments-states of Europe, an era of revolutions began, which had never been observed before. The habitual life was quite deliberately violated, artificial deficits or surpluses were created, and the masses' discontent was triggered off, ***while the money existed in the state.*** They were just taken out of the treasury. In general, the Empire was ruined by the military imperial governors, who were promised the rule and power of a sovereign monarch, they were granted funding, and their soldiers were honored and provided with comfort. It took place all over Europe, there was no one to control it – Russ itself **FELL**

UNDER THE YOKE of the pro-European Romanovs. The former Horde governors, having forgotten the oath (have a better look at the modern Ukraine), immediately got unlimited power in the provinces, turning into independent kings, dukes, etc. ***Surrounding themselves with flatterers and bringing the "faithful Jews"*** closer to themselves, they naively decided that victory belonged to them. However, this error cost them lives. The Pope and his Jews made them submissive one by one, raising the galloping and jumping "revolting people" to color revolutions of the past. The descendants of the same bankers of the past, having gained the power of money, rightly believe now that the hour of revenge has come, as the Slav have finally gotten out of hand. True, not everything goes as smooth as desired. And there are a lot of disagreements in their guild. For example, Russian Jews do not want to "lie down" under the European ones, believing that since they "have crushed" Russia (which Europe failed to do with all its wars against us), then Europe will also be crushed. But so far they have not been succeeding in everything. And especially hard times came to them after 2012.

Let's go back a bit. What happened in the wars of the Reformation? First of all, we have to remember the slogans of all revolutions (French, English, Russian, etc.). In the empire, the principle of the antiquity of the genus and nobility ruled, which gave the right to power. ***After the Reformation rebellion, the wealth and power of money came first.*** And they began to mock openly at the nobility. There, where there still remained dynasties of the reformed monarchies, capital has been ruling for a long time, and monarchs "are cut off" from the world affairs in the main. The Rothschild's – in the Kingdom of England and in general throughout Europe, in the USA – the Rockefellers, – former treasurers and slaves rose all over the world, grateful to their Jehovah's mercy upon them. Their plans (program) suddenly (I focus your attention on this) have become even more ambitious. ***Having at hand excellent material of a deceived own people scattered throughout all continents, a fairly aggressive faith, backed by real victories and money, the treasurers created the ideology of conquering the world, or Zionism.*** It means the globalization and restoration of the former empire in the whole world, where there would rule those who Jehovah "promised" power over all nations. For the sake of this, the Bible was invented.

Today the Jew are considered to have written the Bible. This is all wrong. The priests who glorified God went with the Horde troops to conquer the world, or the Promised Land in the 15th century. ***The very word***

"Jew" is simply an incorrectly read word iereji (priest). The reason is the modification of letter Izhitsa. I think that this was the name of priests in general. Here, only, at first priests were not the usual priests, mullahs and ksendz. These were called zhretsy or **zretsy** (priests), that is, supervisors (in Latin – a bishop). In Byzantium, priests are civil servants who had holiness from the emperor, who was considered a demigod (delegation of God's powers). **That is, just "slaves" of the emperor.** His personal villeins. Including treasurers. Therefore the name of a Jew is not at all sincere, but hypocritical. This is a game for the public. The Jew themselves know very well what they are and where their history came from. That's why there are so many mysteries around this religion that the main thing is hidden in it. What the great Goethe said and what Chaliapin sang about: **People are fighting for metal, Satan rules the ball there!**

Lie is Satan's main weapon. The whole **of hisTor(ah)y** was written in the **17th-19th centuries on the basis of the all-European state program, clearly coordinated with the Romanovs.** They were later treated the same way as they had done to other governors of the Russ-Horde. This accounts for the remarkable coordination of the actions of the historians of all countries, who were supported by the money that fell into the hands of Jews. Who pays, he orders music.

It may seem that in the world there reigns despair, and everything is predetermined. They say, if you hear the word Jew – raise your hands up. This is not true. If the Jew could, they would have long conquered the world. **TO WANT AND TO BE ABLE – ARE DIFFERENT THINGS.** Today, there are many countries in which the Jew are not in their power of money. China, India and others. There is an opinion that in Japan, either, however Japan is still under the authority of the pro-Jewish government of Shinzo Abe and under the influence of the emperor married to a Jew. Therefore, they are in such hysteria from the coming unification of the two Koreas.

The idea of the all-powerful Zionists is imposed by the media; at their disposal is Hollywood – the most powerful weapon of propaganda. But for all their genius in finance, **they are completely incapable of administrative and constructive activity of state building.** You can, of course, argue. The answer, in my opinion, is this – **with all**



its "outer attractiveness", it's a failed project. To live in the country that is constantly at war (Israel) is extremely hard. Therefore, the last time, a global idea is being nurtured- to change the neighbors and move to the Ukraine, which is ready to fall apart. I am sure that the majority of the world states will gladly support the allocation of territory for the new Israel in the hope that the representatives of this guild which has formed into the people will leave their land. But here, for the time being, practically (for some reason) nothing turns out. Why? – Probably it is clear to those who have read my previous books. The worst characteristics of the Jew, such as greed, cowardice, deceit, spitefulness, treachery, bloodthirstiness, lack of principle and meanness, are inherent properties; they are entrenched at the genetic level by artificial selection according to the requirements of the Talmud: **"The best of the goys – kill!" And "If your child sympathizes Christianity, then kill him".**²⁴ The most repulsive feature of a Jew, admitted by the researchers, is ingratitude. The identification of this characteristic of the Jewish people are devoted, for example, the studies of Ruth Okunyova, Jewish by nationality, presented in her book **"The People Unaware of Gratitude"**. The manuscript of the book was published in 1988 in Jerusalem, where the author had to flee from urgently because of persecution by her fellow tribesmen. Ingratitude is like envy and selfishness, vindictiveness and cunning, cynicism and double-dealing. The Jew, in their **GENETIC ESSENCE**, are **DESTROYERS**, as they repeatedly recognized themselves. And this is one of the reasons why, despite their rather long predominant presence in the scientific institutions, they have not given the world a single outstanding pioneer, and all the "scientific authorities" they have exaggerated up to now turn out to be either plagiarists, like Einstein , or barren flowers, like D. Landau, or those sticking to other people's developments using their official position. From the published in Tel Aviv **List of Michael Shapiro's "Jewish hundred"** to pioneers in science there can be attributed none but that **Gregory Pinkus – the creator of birth control pills, by the way, rather harmful to women's health due to hormonal disorders**. The Jew, according to the Sunday Times, are still intensively working on the creation of a genetic weapon against the Arabs (the same Semites like the Jew), so there can be no doubt that such a weapon is being prepared by them against the white race, but this is already a dream, which is not destined to be realized.

²⁴ "One hundred laws from the Talmud", M., "The Knight", 1998.

It is not necessary to prove the mediocrity of the Jew in art. All of their works are essentially imitative. Lack of talent in painting, reinforced by the prohibitions of Judaism on the image of all living things, with the paranoid nature of their ambitions to be at the forefront of everything, gave birth to the so-called "avant-gardism" in the visual arts, which, in my opinion (or rather not only mine) is a daub of a schizophrenic which does not require any skills other than decorator's. Hence all their maleviches with "black squares", as I have already said, and the constant desire to belittle the value of true artists, in order to lower them to their own paltry level, so that it would be possible to create a kind of "competitiveness" for show. And so that all the dividends in any case were gained by only "their own", **THERE WAS UNLEASHED AN ENORMOUS PROPAGANDA OF THE ABSTRACT DAUB**, for which milliard premiums to its "prophets" were given, exhibitions and museums were opened. The purpose of this action is destruction of the entire national art, so that the picture of a Japanese abstractionist could not be distinguished from the picture of the similar Finn, German, Italian... Exactly the same situation is in music. The great **Richard Wagner** ("Jewry in Music", St. Petersburg, 1907) gave a comprehensive description of the musical "product" of the Jew. The secondary character, imitation of Jewish works, noted by him, is quite applicable to modern "masterpieces" of them. So, try to answer this question: why is classical symphony music attractive only for the so-called "selected" all over the world, which, in comparison with the entire population of the Earth, is very small. Never from a Jew, no matter how hard he tries to "improve his breed" at the expense of the Aryans, for some reason, Dostoevsky or Pushkin, Lomonosov or Mendelejev, Surikov, or Vasnetsov, Glinka or Sviridov, K. Leontiev or Florensky would not come out.

What can be contrasted with this state of affairs, including in Russia? First of all, **IT IS NECESSARY TO TELL THE TRUTH** about this "God-selected" people **TO EVERYONE, AND TO THIS PEOPLE, TOO**. Believers should know about the ancient faith – faith based on the true knowledge. During the transitional phase, we can return to the Christianity that was in Russia before the Romanovs and completely abandon **the "Judaizing Lutheranism"**, defined as today's modern Pravoslavie – **it's not Pravoslavie at all, but Pravoverie (the right faith)**²⁵. It is necessary to radically change the economic system, make the producer

²⁵ For details see Book 5, Chapter 1.

independent of bank and paper worthless money, change the attitude towards the Jew – ***stop taking them for the "eternally persecuted people"*** and start using their abilities for the benefit of the state, if there is no other alternative. Well, do not we have to evict them from the planet Earth... They are also people who were oppressed for a long time and who also want to be happy. In what way should it be done? This is the subject of a special discussion and laborious work. And you should not laugh – you have to exclude from your thinking all that is related to violence, and especially towards other people, the history of whose appearance and purpose within the framework of the past and present ongoing processes, very few people know or have any idea about. Of course, one can foresee some angry statements of those who say, the Jew have to be eliminated (...beat the Jew – save Russia!). Well, there were many who were destroyed, banished, persecuted, oppressed... Who has become happier after that? "Outcasts", who got even more embittered, or we, who just have no brains to solve the problem? I am deeply convinced that not "the lack of brains", but practically no one knew and does not know today why it happened this way and not otherwise. Why, we, the Russians, have never tried to solve this problem. This is also an interesting question – why? To make it clear I decided to write this chapter. Everything is much simpler and at the same time more difficult in comprehension. To make it out it takes a little – correctly placed emphasis. There is a lot to do, the situation is too much neglected, and those who have to put it all into practice – should grab the Broom – and run to take the Bath. The problem is too great, and we'll turn to it in this book, but try to see it in somewhat from another perspective, so that no one might think that all this could be changed in a hurry.

2.8. "Mysterious" force

"They are more effective against us than enemy armies. They are a hundred times more dangerous for our freedoms and for the important things that we are doing. One can only lament that each state has not exterminated them long ago as pests in the society and the most serious enemies for the welfare of America. It is very regrettable that no state older

than this has humbled them as a plague of society and its greatest enemies, whose presence America is "blessed" with."²⁶



Per "The National Observer" via a document from Abe Foxman's [Jew A.D.L. president of USA] office. August 25, 1998, New York, NY.

"Gentlemen. Welcome to the Second Centennial Meeting of the Learned of Elders of Zion. We have achieved all of the objectives expressed at our first meeting a 100 years ago. We control governments. We have created dissension among our enemies and made them kill each other. We have effectively silenced criticism of our affairs and we are the richest race of men on this Earth. Many of you are very busy men. Let us get to the crux of the matter. As masters of business, politics, law and most importantly... media, we are ready to implement our most important and ambitious program. One, that will finally and totally remove from existence the impediments of our absolute control of this earth. I speak OF THE DEATH OF THE WHITE RACE. The complete removal of all means of reproduction of the so-called Aryan race. Men, we now control the destiny of this race. It is now time to make sure the White race is getting extinct through miscegenation and having a virtually zero birth rate. We have all enjoyed the vision repeated all over the world every day of THE LAST WHITE CHILDREN playing with little dark children and knowing that they are being set-up for their eventual destruction. We can ruin THE ANCIENT PURE BLOODLINE OF AN ARYAN CHILD by convincing him or her of the altruism of begetting interracial children. We must expose the race-mixing

²⁶ **George Washington** (1732–1799) First President of the United States.

of the urban centers to the suburbs and rural areas of this country. More aggressive programs to integrate these areas are now underway through HUD. It is worth any price to annihilate the next generation of White children. We want every White father to feel the sting of having their children marry colored mates and produce biracial children. We must use our power to discourage White men and women who still persist in getting together from producing more pure White children. They will be ostracized by not becoming part of the New Society of all races. This will dissuade most of them. We will deal with the less cooperative goys by murder and imprisonment. Finally, we will SEE THE END OF THIS WHITE RACE. Impressionable White children will have their minds molded into the agents of their own destruction. Already, our efforts have succeeded in making the "men" of this race grovel at our feet. Men, you and your ancestors have worked hard to make sure we would have the power to hold the destiny of this race in our hands. Now we have it. Perish Aryan Goys (cattle)!"²⁷

Of all the tribal and religious issues brought forward by history, there has not been one more permanent, more universal and more insoluble than the Jewish question. No matter how far we go deep into the past, since the time of the resettlement of the Jew among the other tribes, ***we always come across them in an unceasing struggle with the peoples who accepted them into their midst.*** Their resettlement is much older than the era, when the Roman armies forced them to leave their country completely and scatter around the world. Part of the ancient history and all the Middle Ages are full of echoes of this age-old struggle. At present, this struggle between Jewry, on the one hand, and Christianity and Islam, on the other hand, outwardly, if it had the appearance of less hostility, it is only because Israel skillfully disguised its own, almost always direct and open, hatred in the past. But lift up any of this cleverly fabricated guise, and under the threat of the national security of the material prosperity, religious freedom or the public order of each people, you almost always come across a Jew. Indeed, the Jew changed the economic conditions for the existence of peoples, creating a financial system that allows them to collect and use public and private ruin. The Jew provoked anti-Christian persecution in many countries in order to satisfy the age-old hatred of this tribe against the ministers of Christ. The Jew also put furtively fire into the social building, spreading the ideas of collectivism in the world through their agitators and

²⁷ Speech by Abi Foxman, President A.D.L. (US Jewish Organization) August 25, 1998, New York.

Jewish theorists, whose names were Karl Marx, Lassalle, Singer in Germany; Neimayer, Adler and Aaron Lieberman in Austria; Friborg, Leon Frankel and Halttmayer in France; James Koen in Denmark; Dobrodzhanu Herea in Romania; Cohn, Lyon and Samuel Gompers in the United States and many others. All over the world, behind the scenes of all attempts of moral corruption in the field of literature and the arts, you once again come upon the Jew. Finally, the Jew constantly serve as spies against all states that carelessly gave them shelter. This grandiose work of corruption and destruction, consistently pursued for centuries, raises a question, which to this day has not been resolved. Where is that mysterious power that turned the Jewish people into this "scourge of God", whose role we just sketched in thick strokes? This is the question that inevitably raises before our eyes, when we begin to study the destructive work of Israel in the last millennium. But only in this way can you get the key to clarifying the mystery around which the world politics has been rotating for the past two thousand years.

2.9. "The Mysterious force", or how is everything in fact

World history is not the history of wars and kings, as it is presented to us. World history is, first of all, the history of commodity production and socio-economic relations development. The story began with the fact that **genotype 422 got knowledge of profitable commodity turnover**. I remind the readers that the Ararat Complex created the first Brain genotype 421 in 1605 BC. The Kazbek Complex created the Brain genotype 422 in 822 BC. **The Elbrus Complex created the Brain genotype 423 in 0 AD, completing the formation of the first group, i.e. the Brain genotype 42**. The Brain genotype 423, as more perfect, was the basis for further perfection of possible additional executive functions of individuals of higher governing order and further improvement of genotypes. That's why we are most interested in the period from the so-called "zero year", which the above mentioned characters like to talk big about. Dispersing from the place of its formation (presumably it is the area of Mecca and further to Yemen), representatives of the leading genotype with the help of trade captured the whole of the world, never holding a saber. Robbery and military conflicts followed them on their heels as a consequence and a new form of material goods appropriation. The basis of military robber clans consisted of exiles from the primary representatives of genotype 422, **PRESENTING**

THEIR SUB-GENOTYPE BY THE FUNCTIONAL ENDOWMENT.

The trading tribe, because of excessive love for its members, changed the death penalty for banishment, starting with Cain. Now, apparently, they bitterly regret this. Since the main participants of all the events and the "motive force of the progress" are representatives of the leading genotype, just between them the main conflicts, both global and local, took place. And as the reader already knows from the previous books, *the notion of "Law"* that came into being in their midst forever set them at loggerheads and divided into two warring camps; a once-common genotype split by the degree and quality of the excitement of the gene of selfishness. And this unity and the struggle of opposites we have been observing for a long time. Only unity occurs very rarely and for a short while, while the struggle is becoming ever larger – until the complete victory... of the Interventionist system, which created these conflicts in its own interests.

The Interventionist system was the driving force that guided the human race along the path chosen by this force, cutting short any other possibilities. Representatives of the leading Brain genotypes, endowed by this power with a more perfect mind, were and remain the main executive tool in its hands. The whole world as it is now was built through the leading genotypes, starting with 422 – trading tribes. Trade was "invented" by the leading genotype, being functionally endowed with it by the Interventionist system. The "4xxx" genotypes had one specialization – trade. They, after getting knowledge on the profitable commodity turnover and living on it among other peoples of the Earth, created the present civilization, Indo-European languages and, basically, all the rest, as well as writing. After all, without the needs of professional trade, none of this would ever be necessary to anyone, as, for example, it is not necessary for the aborigines of Australia. They also got knowledge of jurisprudence, especially in the field of private law, since public law could be created without them – based on the needs of the Aboriginal tribes and leaders and just the needs of the people. Then these two laws began to intersect and improve in indissoluble links with each other and with one or another character of dominating one over the other depending on the territories and society. Private law regulates relations arising on the basis of equality of parties, and public law regulates power relations on the basis of subordination. The resulting knowledge has led to the fact that **ANY LAW, BASICALLY, BEGAN TO RELY ON FORCE**, and if there was nothing to restrict it, then this law was aimed at lawlessness. Actually, the result of this can be observed today in full. We are brought to the fact that there is no common understanding in the society, there is a

search for personal benefits and, unlike animals, most people's "appetite is getting bigger while eating" and does not even end up with the forcefully "eaten" countless billions of dollars. Just because the more dollars, the more powerful is an individual, and the bigger the appetite. Such a situation especially escalated from 2000 to 2012. The society is "invented" not so much so that it would be easier live together, as it is commonly thought, but ***to make smarter people live at the expense of less smart fellow citizens***. It did not happen immediately, but gradually. When the leaders and shamans stood out in the communities, the right to the best pieces was balanced by the benefits they brought. No wonder at the beginning incompetent of their positions leaders and shamans were mercilessly executed (read D. Frazer²⁸). Later, the most cunning of them appropriated the right to be elected for life, without taking into account the actions at the post. Next was the right to inherit the post by children. It resulted in the protection of these rights by the sponges, i.e. "squads", the future "elite", ***to which the best pieces are no longer distributed by the people, but by the authorities***.



²⁸ **FREIZER, JAMES GEORGE (Frazer, James George) (1854–1941)**, British anthropologist and classical philologist. Born January 1, 1854 in Glasgow (Scotland). He graduated from the University of Glasgow with a degree in law, became interested in classical languages and literature. After reading the book E. Taylor Primitive culture, decided to study anthropology and entered Trinity College, Cambridge University, where he became a student of U.R. Smith. In 1907 he became a member of the Board of Trinity College. The most famous work of Fraser – The Golden Branch – was first published in 1890. Among his other works are Totemism and Exogamy, 1910, Folklore in the Old Testament, 1918, The Gorgon's Head, 1927.

Doesn't it remind the reader of the present situation as the logical and expected result of those historical results development? They began to manifest themselves after the Jew's penetration into the elite of local aboriginal tribes. As a result, we see the first unbalanced right – the right to be elected for life and to inherit this right by children. The main feature of such unbalanced rights is the impossibility to be recalled. The basis of the society has been accomplished. Naturally, in such a society there is no place for a law court before which all are equal. There is a penalty for misconduct before the "society" (i.e. the leader). There is only the leader's benefit and the benefit of his circle – "squads". So **THIS "LAW COURT" IS NOT LAW COURT** at all. And this **"LAW" IS NOT LAW** either.

Today, both in Russia and in the West do not know where from and how jurisprudence has occurred just because no one understands the true concept of the world history, its initial impetus and the development direction idea. They do not understand, for example, that in Russia the people were exploited by the Khazar newcomers (the Brain genotype 423), who took the people for strangers, about like Negroes in America. This way slavery lasted until the 19th century, based on the Assembly of the Land Code of Tsar Aleksei Mikhailovich (1649), and not as it is described at the beginning of this chapter, from the historians' point of view and those who were "writing" this history Further in line with the text under the definition of "leading genotypes", or "4xxx" we consider the people known among the common people as the Jew. But since **THERE ARE NO NATIONALITIES, but only representatives of the Brain genotypes with territorial binding and functional endowment**, the use of the word "Jew" is incorrect. Below is the table of the leading genotypes:

421 – 12 tribes, 441 – 12 tribes, 461 – 1 tribe,

422 – 12 tribes, 442 – 12 tribes, 423 – 12 tribes.

As you can see, the total number of species of the leading genotype **is brought to 61 or 22% of the total population of the Earth**. At this the Interventionist system program was stopped. In total it was planned to bring the number of tribes of the leading genotypes to 66. Accordingly, **462, 463, 464, 465 and 466 Brain genotypes** were planned to be introduced. Each subsequent genotype that was formed was to take the best from the previous ones. However, it has not worked out.

2.10. Private or Roman

How was private law created (with the idiotic nickname "Roman")? Exactly as it was required for an effective, profitable and secure trade. Genotype 422 (commercial tribe), most likely, began the journey from the south of the Arabian Peninsula as if in two arms. The eastern arm was combing the eastern countries and peoples (Babylon, Persia, India, China, the Caucasus and further to Europe), stayed there, bringing in the local languages something of its own and changing their own language – later becoming an Indo-European family of languages. The Western arm, moving through Ethiopia, Egypt, the northern coast of Africa and further across Gibraltar to Europe, in the same way creating the Afro-Asian family of languages, in which, eventually, the Indo-European family joined, naturally, with the Europeans. Linguists can not explain this in any way.

Private law came into being from private property (for genotype 422 – for the goods). Where did this private property come from? Since no people on the Earth but the representatives of "4xxx" genotypes have never "resettled" or never taken root among other nations in its full composition, there must be a conclusion made that exactly that place on the Earth where "God created" the given people – is their land property – absolute and unquestionable. ***Purchased land property, as an object and concept, is inculcated in our consciousness and law by the leading genotype 4xxx.*** In most cases, the purchase was fraudulent for a millionth of the true price, which did not have to be regulated by law, not to mention the conquest of the land, also on behalf of the commercial tribe – its robbers' part. For example, both the Palestinians and their closest neighbors know perfectly well that the people called "Jews" have never been "created" at this very place in the district of Jerusalem (the Palestinian village of Al-Qudes) either by some god or devil. And the arbitrariness of the "democratic West" they take in the same way as you would take a tramp who broke into your house and told you: "Now I will live here, I like it here, and the world council of presidents does not object".

The next institution, created by the "4xxx" to protect their property, did not concern the local population at all. ***This is the court based on private law.*** The Old Testament court on the basis of private law should not be confused with the law court arranged for the goys on the basis of civil law – the right of the kings to punish the commercial tribe was developed in detail long before the writing of the Bible. Private law and an independent

law court were invented by the trading tribes of the "4xxx", since trade itself without these institutions was impossible. The law court independence was understood by them differently from today's – as independence from the authorities and corporate interests, but in the more ancient understanding – independence from civil law in general, that is, the right of the "kings" to punish their "children". In other words, the ancient trading tribes from the moment of trade appearance (the movement of goods between peoples) created their scattered inner mini-state in every country. Since then, the notion of "state within the state" has come into use. The Sanhedrin²⁹ was created for all this.

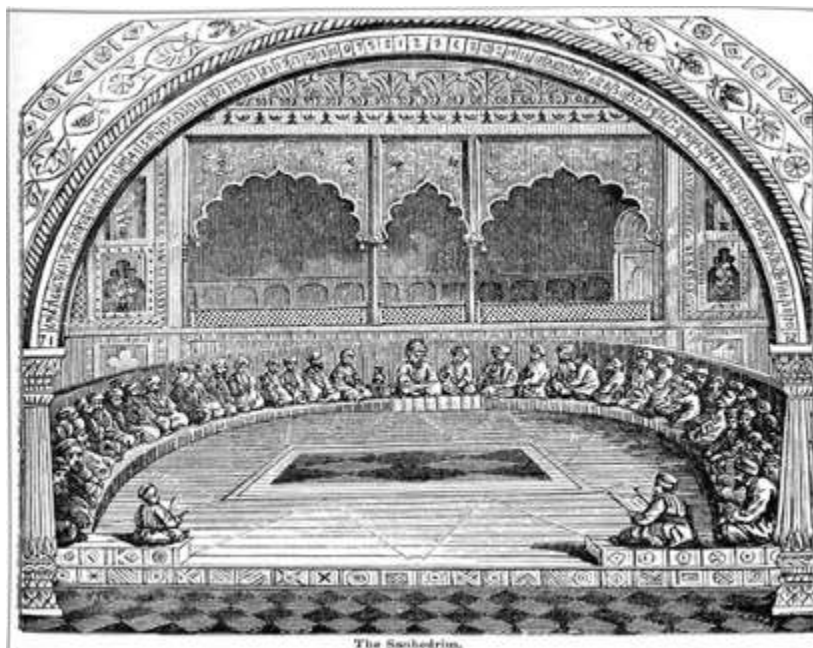

Initially, the Sanhedrin is the Supreme Court, which pleads particularly important and complex causes of tradesmen, the principles of the Jewish justice administration and the order that instructed the Jew in the procedure of court examination. That was why the "4xxx" did not obey the civil law of the countries of residence, creating a "state within the state". The court was given to the midst of the leading genotypes right from the "world creation", since before them there had been no written history at all. The leading genotype began to form a legal field for the conquered peoples in order to be able to indirectly model the legal behavior of the population in their own interests. The legal field is just an instrument that can be used with diametrically different consequences. The variant of its application, which was found in the hands of the "4xxx", only aggravated the situation of the

²⁹ **The Sanhedrin** (Greek **συνέδριον** – "assembly", literally "joint meeting"; Hebrew. סנהדרין, Sanhedrin) – in Ancient Judea – the highest religious institution, as well as the highest judicial body in each city.

indigenous population and **PROMOTED UNLIMITED LAWLESSNESS** for the side of the leading genotypes, only worsening over time in relation to the conquered peoples.

The "God-selected" have always lived within the framework of their ancient, primary, given by the interventionists law system. They still live that way, taking the legal norms declared for the society in a demonstratively devil-may-care way. The first weapon on the Earth is ideology. So the first representatives of the leading genotype at the beginning of their journey to the lands and peoples were armed with the doctrine of Judaism in addition to knowledge of trade profits, which was not given to them in a complete form and eventually was being changed. Since the main motivation for expansion was the desire to make profit, the leaders in the community of genotype 422 were the heads of trading families. It was they who gathered periodically together, worked out the rules of internal relations, divided spheres of influence both over the territories and by groups of goods. The first composition of the Sanhedrin was represented by the most respected of them.

Soon the doctrine of Judaism took the form of moral precepts and was usurped by the Levites, former servants of the heads of trading families (kogans) in the matter of exercising the cult of the family deity, ***Elu. There became one God – Yahweh,*** and the commandments were mixed with the morality and the liturgy in one "vial". As a result, the Levites seized ideological power within the genotype, becoming teachers (rabbis) and, since morality became a religious matter, they took on the functions of judges. The "4xxx", living in isolation among the aboriginal tribes, never obeyed the local public law that existed there (everything belonged to the leader). They have never had their own king or state. That's why they needed their own courts, independent of local leaders. The so-called Deuteronomy was "born." The dominant content of the book of Deuteronomy is the reproduction of the historical and legislative elements of the books: Exodus, Leviticus, Numbers (with the inclusion of some new legislative provisions). The book gives a young generation born in the wilderness a retrospective review of the path that the sons of Israel have made in their striving to reach the Promised Land and the laws they received through Moses. The same edifying purpose has also the accusatory-admonishing speeches of Moses, placed in the conclusion of Deuteronomy. In general, Deuteronomy is a detailed dying testament of a wise and experienced leader, endowed with inspiration from above, to a young, unstable Jewish people. The common idea of Deuteronomy consists, in general, of two points: ***freedom of religion and***

human freedom. Freedom of religion is, in fact, like Gorbachev's "pluralism of opinions." Since Moses was a pureblood 4xxx, he chose Judaism for his tribe out of all pluralism, leaving all other shades of pluralism to the free discretion of other nations. That is why in Deuteronomy there is not a single moral commandment, but only the Liturgy to Yahweh, the main feature of which is kosher food – so that "birds of a feather flock together". This greatly contributed to the fact that the tribe dispersed throughout the world became monolithic as a stone. Thus, Moses' Byzantium is the first and last Anarchy on the Earth. To erase Moses from history is like to forget the Second World War. But everything that Moses did on the Earth can not be shown. It was he who first proclaimed democracy and liberalism. Not only proclaimed, but also carried out in their primary semantic version in Byzantium of the ancient Hellenic Greeks.

2.11. Specific biomaterial

It is clear to everyone today that neither the Rothschilds nor the Abramoviches (in the broad sense and not only of the surnames) without criminal fraud even for a hundred lives would not be able to make their own wealth with their own heads and hands. But the human brains are so much ruined by Interventionist propaganda that everyone is ready to accept this idiocy. If we take into account, for example, just the head – is it really that Abramovich or Aven, or Friedman are smarter than Newton or, say, Grigory Perelman? Of course, not. But the latter used their heads for the good of all people without exception, but the Rothschilds and Abramoviches used their brains only for themselves, to live at the expense of others. This is the intra-species parasitism. Let's take our Spade of knowledge and dig deeper and deeper with it, but from the side of truth. Then, long ago – two thousand years ago – as a result of hard life's trials and unfulfilled hopes, in the struggle for emancipation – freeing themselves from the Babylonians, Assyrians, Greeks and Romans who conquered and captured them, the Jewish people priests made their choice, made the choice for their people , **and together with them the Jewish people made their choice.** Glorified in modern Jewish books dedicated to outstanding historical Jewish figures, a descendant of rabbis – **Karl Marx**, who perfectly knew the problem "from inside", had his précised say on this occasion: "What is the mundane basis of Jewry? Practical need, self-interest. What is the mundane cult of a Jew? Mercenariness. Who is his mundane God? Money ... A Jew

emancipated himself in a Jewish way, he emancipated himself not only by appropriating a monetary power, but also by the fact that through him money became world power... "Money is a jealous God of Israel, in the face of which there must be no other God..." Jesus Christ appeared precisely at that time and it was among the Jew in Judea when the choice had been made. And he appeared to bring to reason the Jewish people, to return them to spiritual channels, to turn them away from material orientation. It did not work out, but the attempt was made.

According to the definition of Academician N. Morozov, the author of the fundamental work "Christ", **"a Jew" is – ebr** (immigrant). However, there is no data – where did the resettlement take place from and in what way. It is not known where the expression "yogi" came from and, accordingly, "goy" by the type of bar-rab (slave). Why is the tuning note for all musical instruments **"La" (440 Hz)** defined as the number of Satan? Why do only Jews have the right to occupy posts of doctors, archivists, bankers, lawyers (usually attorneys)?

And, finally, what is anti-Semitism, the Holocaust?

Ancient Greek manuscripts read: **"Musical education is the most powerful weapon, as rhythm and harmony penetrate into the innermost depths of the human soul."** The note "La" originally had a frequency of 432 Hz. The first attempt to massively change frequencies occurred in 1884, but with the efforts of G. Verdi the old system remained, after which the tuning of "La" = 432 Hz was called "Verdi's system". Shortly before the Second World War, in 1936, the Minister of the Nazi movement and the secret leader of the masses control P. Y. Goebbels **revised the standard, replacing 432 for 440 Hz** – the frequency that most affects the human brain and can be used to control a large number of people and as propaganda, including Nazism. This was due to the fact that if you deprive a human body of natural tuning and make the natural tone a little higher, then the brain regularly gets irritated. In addition, people stop developing, there are a lot of mental disorders, people begin to retire into themselves – it is easier to control such people. This was the main reason why the Nazis accepted the new frequency of the "La" note. And in 1952 the order of 440 Hz as the main one was universally adopted. Even after the adoption of the standard, in 1953, 23,000 musicians from France held a referendum in support of the "Verdi" order of 432 Hz, but were politely ignored. **Only 8 Hz difference, but 432 Hz is a healing frequency, and 440 Hz is a depressing one.**

So, "**La**". In the musical series **Do, Re, Mi, Fa, Sol, La, Si** the note **La** is the sixth. The Star of David also has 6 corners. The 3-fold repetition of the **La (666)** note is the encoding of the input and output signals to the Brain intended for processing the subsequent text transmitted by the 12-register row (*translation table 12-12*).

Nobody ever tried to decipher the translation table, in which, for example, **DoDo** is letter "**A**". Scanning a table is a solution to the Hamilton problem for dimension 256 (it takes billions of years to get the result).

Every 36 months on reference N^o2 (Israel), depth – 4510 meters from the surface level, there appeared UFO (code 216, octave of displacement is 288, octave of state is 76, operating octave is 50). The last arrival was in April 1995. I remind the readers that the information on UFO, codes, octaves, operating frequencies and much more you will find in detail in my previous four books, linked by a common name.

Each Jew (and mutant, respectively) has a code entry in the cerebellum – a record length of 54 points of 24 beats (each point). The record is in binary code. This is the state scale. It is scanned by a UFO (the entire Earth is scanned) on octave 33 **Mi**. In the scale of the state there are copies of 16 commands. When the order (UFO) and the command coincide, the execution follows. If the command is not executed within 36 months from the moment of its transmission (until the next arrival), a command to self-destruction follows.

Sequence of incoming commands. At octave 32 **Mi** there follows the group: (**MiDo**) 32 (repeated 32 times); followed by a group at octave of repetition – preparatory. The second series – (**DoMi**) 32 – executive series and followed by – the executive series of commands. If there is an entry to read the information, then at this time the information octave rises. The state scale indicated more than 1 million ways of destruction – 2^{24} , – practically, the choice is not limited.

Example of a series:

((MiDo) 32 (ReFa) 48 <T> (DoMi) 32 (FaRe) 48) 3

T is the execution time in binary code (seconds). The whole series is repeated 6 times. This is the first layer of control systems, followed by robots (there are already 0.6 billion people on the Earth) and cyborgs (there are – 0.3 billion). Those are the Jew who are "untouchables". This is A. Khatybov's definition, and you can not but agree with him.

Commands series

Nº	Name	Command's code Preparatory	Execution commands	Comman d's octave	Numb er of repetiti ons	Comments
1	Self- destruction	(DoRe)16 (NaDo)16	(DoNa)16 (DoRe)16	16 Na	16	Usually ritual
2	Self preservatio n	(SolDo)33 (DoRe)33	(DoSol)33 (DoRe)33	33 Sol	33	«Hide», unite
3	Waiting	(DoSol)24 (DoRe)24	(SolDo)24 (ReDo)24	24 Fa 24 Fa	24 24	People Things
4	Execution	(ReDo)8 (ReNa)8	(DoRe)8 (NaRe)8	8 Do 8 Do	8 8	Destruction of material things Killing of someone
5	Information reading	(ReLa)44 (ReFa)48	(LaRe)44 (FaRe)48	44 La 48 Fa	44 48	Material things People

To make orders, there used a series: ***Do, Re, Mi, Fa, Sol, La, Si, Na*** (Table 8-8).

So, a yogi has a Brain capable of processing codes, a goy does not have such a Brain. Now we consider all correlations from a different point of view. ***Let the ebrs (the Jews) are also people.*** What does it mean?

It means that no extraneous structure can be moved to live on the Earth without destroying everything that there is on the Earth and introducing a new atmosphere and its own life support system. However, all this was not required. It was enough to find an experimental base for testing all the parameters sets and then transfer the necessary frequencies to normal shirts (even with a Ryazan-like mug).

Thus, the first point. From the entire population of the Earth, left after its capture, a specific biomaterial was selected to work out all vital functions. The selection was successful – tribes without habitats, **BANISHED FROM EVERYWHERE FOR THEFT** and being used to life difficulties, unscrupulous in the means of achieving the goals and in the majority being killers. After a short hesitation, it was determined that they were chosen as the base material for conducting experiments.

It is known (from the history, the works of psychiatrists, etc.) that the percentage of sick people among Jews is much higher than that of other peoples, that is, new introduced frequencies did not always end safely. At normal outcome the structure was formed in a normal healthy shirt (such as

Chubais). The waste material was thrown away, there are many ways (including the holocaust).

With the massive introduction of the next frequency there were also major losses – the bulk of the biomaterial completely lost everything that had already been introduced, and then the schemes of destruction in a natural way were developed, and all anti-Semites were former Jews who could not get a new Brain, there is a wall of Lamentation for them, synagogues, tourist camps and places of rest.



The maximum number of installations is **6 million**, therefore, since the Middle Ages (plague in Europe), this number has been used.

It is known that for the patients, on whom experiments are made, ideal conditions are created for the successful completion, until the program is completed. For Jews everything was created – religion, "knowledge", professions, the possibilities to take any posts and be said to be geniuses.

However, it is impossible to implement the program for introducing new frequencies without internal control and correction, some roughness can be corrected on the spot, all conditions have been created for this.

Doctors Jews had to test the effect of the drugs using a different biomaterial. **Bankers Jews** had to make the entire population obey all the program directions. **Lawyers Jews** should not allow prosecution of Jews for their experiments, creation of Gulags, psychiatric hospitals and other holiday homes for the goys. The Control System took care of the well-to-do existence of the Jew, who were transmitted that with the advent of Mochiach (2008), the "golden age" would begin for them.

The results of the experiments accumulated for 2000 years, and it was decided to move in full composition of all those who would make up the "golden million" (a total of 980,000 matrices). One of the signs is ebr – he must be "circumcised". And the process of circumcision of the newborn allowed his Brain to be placed immediately in certain frames of the planned programs for the development of the Brain genotype. In addition to the Jew, other peoples – Tatars, residents of Central and Minor Asia – were used, **more than 4 billion people for the sake of 1 million**. After the normal movement of ebrs, all biomaterial is to be destroyed as waste. The beginning – autumn 2007.



Since the attention of the whole world is focused on the Jew, and anti-Semitism is growing, their destruction will be received with joy, although no one suspects why they existed and why the Almighty supported only them. It was for the Jew that the aureole of martyrs is made up, only they have the opportunity to communicate with God without intermediaries, it is in their midst there are the largest number of psychics; and any new introduced frequency requires special care for those who are under the test. There is not and can not be a Jew who would have got a complete set of all necessary frequencies. As is customary in medicine, every new drug is tested on an individual patient. It is impossible to give everything to one patient – it is not known, what drug may make him feel sick. Therefore, the standard set of any Jew is animal functions and some of the new frequencies. If he exists with them for over 90 years, then the proven transfer channel works already for those matrices which will exist in perfect shirts.

So what (who) are ebrs? Let me remind the readers that **THE EBR IS THE EVOLUTION OF THE PROTEIN MIND**. It has a limit. Let me explain a little: the evolution of the protein mind is the development of the mind within the protein (physical) body of people created within the framework of the Brain genotypes development. This mind is limited by the protein organism, which is called people. Throughout the life of the protein organism this mind grows and develops, but can not abandon the protein membrane and start a new life on its own.

The Ebrs fulfilled their function and further are to be utilized. But as we see, they do not feel like this. "Come on, ...here there's an opportunity..." And – forward! That's what, actually, we clearly observe in their actions today. Well, they do not want to..! But, I assure you – the process is already going on, gaining momentum.

So, what do we have after reading four books and two chapters of book 5, if, of course, there was enough patience:

The Ebr appeared on the Earth ***about 18300 years ago, eliminating the Brain of the previous civilization.***

Jews were experimental biomaterial for the "golden million", which was to appear after the end of the Program – **they are ebrs**, and their "shirts" were to be replaced for people's shirts.

The experiment was made for more than 5,700 years, there were introduced over 140 (basic) control frequencies.

The Jew were chosen as yogis (the presence of a receiving and transmitting device in the Brain for communication with the Ebr Life Support System). All the rest, of course, are goys.

Jews were provided with the possibility to make corrections of the frequencies by medical experiments on goys, with the full support of the Ebr Control System. The growth of anti-Semitism is a manifestation of discontent among those Jews who have not got new frequencies and are looking for a chance to become a Jew, otherwise all of them are subject to annihilation.

Jewish musicians can compose and perform only the music that is on the command line. For the goys, the rock was developed that does not contain any commands.

The first Jews on Earth were Armenians, but they got all the necessary frequencies, have code **xx.44**, where **xx** is a sequence of frequencies in

octaves. This means they can no longer be used by the ebr, since the frequency limit is reached and most likely they were to be just annihilated. However, this has not happened by now.

It was planned that upon completion of the Program, the Jew would no longer be required and would be removed by the ebr as waste, and the "golden million" would arrive at SUR formed by the Jew plus about 240 million servants from those peoples united by the word RUS (SUR – is the name of the 4-th star in the Big Deeper, from where the ebr arrived). From N. Morozov's research it is known that all the astronomers were interested exactly in the Big Dipper. In the reference book on mathematics, all the remarkable curves refer to celestial mechanics.

The entrance fee to the "golden million" is a scam, you can not enter into it without having the right frequencies. Well, at the present time – even more so.

2.12. The blues being regenerated

What is known about everything else? Was there any opposition at all? I dare say there was no opposition and it could not have been – everything has been destroyed for the last 18,000 years. Only the Ebr Life Support System was used, which, within the framework of its Program, rejected those forms of life that could not exist after the introduction of the "golden million". Therefore, one should not be surprised today with the abundance of dead fish, deer intestinal perforation, mass death of pigs and so on, since all this is automatism in the execution of the old, already "stopped" programs. The most favorable habitat for them is the territory of the northern part of Russia, near the source of the Volga river, where whole towns are urgently built, few people know about their purpose today. Of course, the most obedient Jews could be saved as a model for imitation, providing them with a privileged position and supporting their existence, but they could not have the whole set of frequencies of the "golden million".

Now about the age. I note that the performers of all commercials are under 30 years old. This is the age that had been envisaged for the "golden million" without reincarnation. Only the "golden million" was supposed to have the abilities of Messing, Vanga, Nostradamus and others. Jews will not need it. Within a short time, all types of drugs were to be eliminated along with producers and distributors (and consumers),

alcoholism was to be completely eradicated, as well as all robot-killers, prostitution, fraud (along with bearers). A large-scale "sweeping away" was to be carried out, as a result of the implementation of the planned ebrs programs. The population of the Earth was to be decreased noticeably, for lack of need to conduct large-scale experiments, compact ghettos where everything would be allowed were considered sufficient. It was a plan that was about to be realized. But it did not happen... Since October 1985 to the present time a number of grandiose phenomena, actions and events have taken place on our planet in many spheres of our life support, including spheres of energy existence, **WHICH ARE STILL** beyond the knowledge of the main part of the present generation of people, but partially observed as some unexplainable effects of their manifestation, like cataclysms of different nature. The examples of this are more than enough. All this – both the ongoing observed transformations, and much of not understood phenomena, led to the cardinal change – the **LIQUIDATION OF THE PROGRAMMED PROCESSES** of the old Control System, on the one hand, and the beginning of the reconstruction of the system-control functions for the objects and Complexes of the true Earth Control System, on the other side. But this process is stretched in time and therefore the formula – "will wake up tomorrow – "all will be nice, and happiness will have come..." – does not work. There should be much to be comprehended, if, of course, there is an urge for this. Everything that had happened before, which was taken for the history of the civilization development " can not be explained by the present science, since the predominantly inert methodological platform of the materialistic worldview does not allow it, and the subsequent stage in people's gaining the knowledge of the truth on the basis of materialistic idealism – is just beginning, especially among those who have realized that at least for the Bath one should strive. People can not influence the changes in all the large-scale events, and the consequences are extraordinary – ***within a very short time, the programmed changes are made in the control of the environment, and the habitat on the Earth, with all the following consequences..*** Everything that is happening today excludes random actions. Absolutely everything is under control, including the processes related to the life preservation on the planet and the change in the objective and functional sense of the people's life in general. The territory of Russia will not be escaped, but the other way round, no matter the way you emotionally take the ongoing events, **IT IS BEING ENDOWED WITH ABSOLUTELY DIFFERENT, MORE IMPORTANT FUNCTIONS**, unlike those that determined its former

miserable existence as a kind of ***passive raw universal donor in the footnotes of history in the past programmed processes***, a small part of which we examined in this chapter. This historic moment associated with the implementation of all programmed changes, including complex environmental changes, ***is called the Transition Period, which we are discussing in this and the previous books, and to which, as to the obvious facts of today, we will turn to again.***

Answering numerous questions and, in particular, the one that mostly worries people – "...why is there no improvement? Why are the actions of "the mighty people of this world" (basically Jews) already on the verge of insanity? Why is the inadequacy in their behavior and decisions exceeding the reasonable limits? "Answering these and other similar everyday questions about the deterioration of life, I want to state that everything is developing exactly as it is to be developed. Everything happens before our eyes. Another matter whether people are able to see what is shown to them in the "pictures" (and many things are told and shown and broadcast on TV), and put together this mosaic so that **THE WHOLE PICTURE COULD BE SEEN**. Here everything depends on an individual and on his desire to take the Bath, catching up the Broom. But, unfortunately, there is the so-called automatism of our executive activities which hinders much. Trying to understand and assess the happening, do not forget in what way and for how many thousands of years our brain was "mutilated". But the fact that the "History of the old worldly state" of the entire world community ***has no longer reality of its current and future fulfillment***, and that **THERE IS NO** more future for such a vicious civilization development, must be taken as a basis in our striving for cognition. The state of humanity, which is already beginning to clarify, can not be achieved somehow by itself – its formation will be initiated and already started by the present-day people and through them. In what way such a man can be involved in this process – mostly depends on his ability to develop, adequately assess the ongoing events in the changes of life-support environment and reasonably react to them, for which it is vitally important all round information support and abilities for analyses, and in addition to all this – a significant share of extravagance, unlimited imagination and complete disregard of the rules and dogmas.

Here on the basis of this, try to make conclusions for yourself, realizing that **EVERYTHING THAT IS HAPPENING EXCLUDES RANDOMNESS and is perfectly controllable.**

There are no, and can not be any derivatives of administrative and organizational structures that would be able to replace the Control System or its correction, except for the Earth Control System itself. However, I want to emphasize once again that the state of the "dull-aggressive apathy" of the bulk of the country's population is extremely important and most difficult subject for today. Here I mean our Russia, although this applies to other territories and peoples living on them, but to a lesser extent. No successes or grandiose decisions of the authorities can raise the people's spirit up to the state of "labor", since **it is lowered down to the level of "work"**; money is gradually losing its previous stimulating role, the changes in social life make people more embittered than happy. **Such a state does not depend on the will and wish of people, the mobilizing traditional effect turns into affect.** But this indifference is extremely dangerous, since "the worsening of any nation-wide states" is more pleasing to the people than upsetting and mobilizing. In the current situation, it is necessary to raise the people (but not raise them to rebellion, as it was before), **BUT THERE IS NOTHING TO "SURPRISE" them SO FAR.** And it is required, and no matter the readers react to this, **surprise will work, and this surprise is possible only through a real national idea**, but not the "national idea" that it is tried to be imposed upon us, but the one that brightly calls to move to the true future. Such an idea can and should be the idea of building a new society – Mankind. Do not consider it too enthusiastic. So will it be, and this book or rather the information that is contained in it – is the confirmation of this.

Where are the changes of our being directed now, which, in the worldly plan, are perceived as the ordinary people's life worsening? The main vector of today's and future events is aimed at the liberation of all the people to be preserved and especially in Russia, from the "oppressive benefits" of the Anglo-American-European system of parasitism of the "Complex Violence Market", which **IMPOSED FROM OUTSIDE** the destroying hegemony of an **INSIGNIFICANT IMPOSTORS' MINORITY** that led to social parasitism over the majority of indigenous peoples through **the financial fascism forcibly organized for them (these peoples), national-demographic fascism and bureaucratic clan fascism, and also technology--raw materials quil-rent and military-force pressure, excluding any responsibility for the consequences of the hopeless majority's existence** and independence in choosing the ways of its own regional development. Thus, "parting with certain simplicity of understanding of the ongoing events» – is forever. Of course, new schemes

and new classifications are coming into being that will simplify the previous ones; making our vision of the world and avalanches of events in which we all take a direct part more harmonious and logical. These new schemes, lined up through people's thinking with the transforming Brain, will turn into factual events. But these are details; for the main thing to be understood is that the world is really complex and lies beyond the limits of clearness. "Scientific revolutions" of the 20th and early 21st centuries resulted in the fact that Man is already ready to face new difficulties, new "improbabilities" that are even more irrelevant to "reality" and contradictory to "common sense". And especially this applies to people living in Russia today. They are ready not only to take them on trust, but also put them at the service of their practice. More precisely – Man's thought, losing the simplicity of the usual horizons gets more space. The prohibitions on "that is impossible," are getting less. But ever more you have to think about the meaning of those concepts that until now have seemed obvious. But even this is not the most important thing. The most important thing is – so that all this should happen, we need the "prepared" Brain. The solution to the problem of such "preparedness" was found by N. Levashov when creating his Generator and, of course, the Programs that came into being after the analysis of the information that was found in A. Khatybov's works and applied in practice. That's when the right way to the Bath opens. It is in short and to the point. And those who want to comprehend it – take the work – **"The Fundamentals of Mankind's Formation"**³⁰ and read it with a pencil in your hand. And take into account – *reading is not safe , but if you started, then this journey will be infinite.*

Here are the words said by Nicolai Roerich, after our victory in the Great Patriotic War and before his death, with which I would like to finish this chapter: *"The last war among people will be the war for the truth. This war will be in every single man. The war – with one's own ignorance, aggression, irritation. And only radical transformation of each individual man can become the beginning of a peaceful life for all people".*

I wanted to finish this chapter and move on to the next one, but before I decided to share information that directly confirms what I stated in this chapter, if, of course, to look deep in the matter

³⁰ Scientific Research Institute "Center for Preventive Strategies" <http://www.salvatore.ru>

Reference:

1. In the near future, the descendants of the Dutch colonialists of Africa – the Boers – can resettle as refugees in the Stavropol Territory. In the near future the representatives of this people plan to visit Stavropol and find out how they can move to the region.

2. An epochal event of the beginning of 2017, which the world media did not even mention casually, was the landing of **the first group of immigrants from Israel** headed **by Igor Gekko** (Berkut) in the port of Odessa. This group of 183 Jewish pioneers arrived in the Ukraine from Haifa **to lay the first stone in the foundation of Heavenly Jerusalem** on the fertile land of South Ukraine. It became known that the Heavenly Jerusalem by 2027 will have been a center of prosperity for the Jewish settlers, built on the technologies of the 7th economic order. According to Igor Berkut, who is revered in Israel as "Mochiach Ben Yosef" (although he is not a Jew), the money and decisive breakthrough technologies for Heavenly Jerusalem will be given by the largest banking houses and world multinationals, most of which belong to Jews. The Heavenly Jerusalem Project is a practical answer to the prediction of the well-informed political heavyweight Henry Kissinger and the late Palestinian prophet Sheik Yassin that **by 2022-2025** the residing of Jews on the present territory of Israel will have become impossible **due to the aggressiveness of the surrounding Muslim population**, natural anomalies and the future cataclysm of "The Battle of the End." By the end of 2022, 6 million Jews from Israel and more than 12 million from Russia, the United States and the European Union countries are expected to arrive in the New Motherland.

It is easy to calculate that $6+12=18$ million, that is, the absolute majority, compared with the claimed 15 million of the indigenous population. Heavenly Jerusalem will be announced immediately after the law is passed on decentralization of the Ukraine.

3. Pope Francis continues to amaze and admire. Recently, the Vatican **promulgated a program document, which for the first time recorded an official refusal of missionary work among Jews**. From now on, the Jews (according to the Catholic doctrine) **are the only**



people on the Earth who do not need the "good news" of Christianity to save the soul. It turns out that, despite the fact that the Jew do not believe in Jesus, Catholic theologians recognize the salvation of Jews as "theologically uncontroversial" and declare this glaring paradox as an "unsolvable divine mystery". Like, if the Almighty promised to save the Jews, he would cope with this task – without the help of Christians. This revolutionary step in the development of Christian theology was timed to coincide with the *50th anniversary of Nostra Aetate, the declaration of the Second Vatican Council*, which largely revised the attitude of Catholicism to Judaism and *condemned attempts of forcible baptism of Jews*. I remind you that until the 1960s, on Good Friday, Jews were accused of "perfidiousness," i.e. the crucifixion, and this charge was withdrawn from the liturgy by the Second Vatican Council, which declared that "the covenant between God and the Jews continues to function". Now the Pope's throne took the next step, declaring it unnecessary and voluntary to involve Jews in the Christian faith. The document named "*Gifts (i.e., gifts to Jews) and the calling of God are irretrievable*" contains a number of important messages. In particular, it is noted that Christians can not be anti-Semites, because their religion is rooted in Judaism. Moreover, at a recent meeting with Jewish religious leaders, Pope Francis 1 stated that anti-Semitism is not only attacks on Jews, but also against Israel. Pope Francis I broke all the records of "Judaophilia"³¹, manifested by his predecessors. He agreed that "*there is a Jew inside every Christian*" and stated that "*you can not be a real Christian without recognizing your Jewish roots*". Stressing the continued presence of Judaism in Christianity, Francis went further than John Paul II, who called the Jews "elder brothers" of Christians. Francis said that he prays daily with the words of David's psalms as a Jew, and then performs the Eucharist rite as a Christian. In a large interview with the Spanish newspaper *La Vanguardia*, the pontiff expressed the opinion that the dialogue between Judaism and Christianity should include the study of the Jewish roots of Christianity and the "flourishing of Judaism in Christianity". The Pope admitted that this is a very difficult and explosive subject, as he put it, "a hot potato", but he expressed confidence that "they can live like brothers." The Pope spoke out against any religious fundamentalism, saying that it is always based on violence, and nowadays violence "*in the name of God*" is absurd.

³¹ Philosemitism, or **yudofiliya** is a manifestation of interest, respect for the Jewish people, its historical significance and an assessment of the positive influence of Judaism in the history of the world (as a rule) by non-Jews

There is no doubt that the reader himself will understand and make out his own conclusions, but I just want to explain to everyone what I have already said, and not only I, but also those who are told about in my books : Religion is a special form and methodology of cognition of the world, conditioned by belief in the supernatural, including a set of moral norms and types of behavior, rituals, cult actions and the unification of people in certain controlled organizations (church, religious community, etc.). But now religion is already atavism and the new "scientific religion" in harmony with the new state of Mind is a part of the whole series of the control instruments at a higher level than the past now restrained Ebr control processes. Russia can and must possess this instrument. Sacral-historical materials should be transformed into new or another state, giving them an explanatory direction, and the mysterious uncertainty and rigid incomprehension in everything – to reduce in people's consciousness to the minimum. That's what I tried to do in this chapter. I am sure that, despite today's attempts by churchmen to "revive the faith", Man of the near future, having gained the Mind of a different state, will perceive the current ***base of religions as nothing more than an exciting historical scenario of the ethnic cultural heritage of the past.*** The same applies to what was said in this chapter. I tried to draw your attention to those aspects of the Man formation process that reflect his current state and his perception of everything that is happening to him and answer the question – why everything was exactly like this and could not be otherwise.

Chapter 3. To make a lot of steps for the sake of the next one.

In principle, it is difficult to think. And it is even more difficult to ponder over the way you think. But the most difficult is to say what you think of your own thoughts.

No knowledge is ever sufficient. There are some who need more, there are others who need less – it is not that important. What is important is that all those who are interested are active accomplices today in a very important process – a new stage in the process of Cognition, which we call, in the first approximation, materialistic idealism³². And for those who are not interested, there is their own stage of knowledge. And it consists in the fact that neither Leo Tolstoy nor Feodor Dostoevsky are not of this realm now, because not a single thought of them fits into **Twitter** or the status of **Vkontakte**. Man can think freely if he is independent on the "hypnosis of authorities" if he does not seek to hide behind the back of "genius", if he is able to have and defend his point of view without fearing the opinion of the "crowd". For this, he has to rely on the trustworthy world outlook and, most importantly, materialistic principles. I proceed from the fact that the father of any science and scientific theories is materialistic philosophy – not political science, by which they tried to replace philosophy, but exactly materialistic philosophy. Developing within the materialistic worldview, **scientific theories** in my opinion, should absorb, like a sponge, its basic principles ("genes"), as if copying the materialistic theory of cognition. In this case, the scientific theory will become a projection of the materialist theory of cognition on a specific subject of research. By force of this, the structure of the materialist theory of cognition should be similar to the structure of natural science theory. This is exactly what was realized when creating **the "SvetL" Programs** for the full-scale operation of the Generator used in **the "SvetL" Complexes**, taking into account and focusing on the application of the Programs for the correction of the

³² After the change of Control System (2011.04.24), a very important change occurred in the very process of the truth cognition, about which our philosophers are silent, to our regret. The process of knowledge has moved to a more perfect stage – Materialistic idealism. Previous stages: Idealism before 1841, Materialism 1841–2011.

personality psychology of an Individual and ***the Human Capital***³³ that is formed through it, which influences the transformation processes and, to the so-called globalization imposed on us from the outside, and many other factors, which we are going to discuss in this chapter. I laid this analogy in the basis of analyses and syntheses of the materialist theory of cognition of the globalization strategic psychology and the main property of not the country but of ours, – ***the Human Capital***, from the point of view ***of the energy-information dialectics of the Brain genotypes development***, but not from the point of view of "authorities" who dreamed of implementing globalization plan in the framework of achieving their plans, which we talked about in the previous chapter.

3.1. What is taking place

Wars, diseases, man-caused and natural disasters that are taking place all over the world, take more and more human lives. The current grave situation in Russia is by no means accidental. And the problem is not because of "bad" politicians and the so-called "representatives of the state power", whose activities are visible to everyone. Of course, there are problems of the economy, but there are also ineffective people emerging from nowhere like larvae in a latrine, who try to solve these problems of the economy with their "financial instruments", being absolutely ignorant of the country in which they live, or the economy of this country. They have never been in this economy! They have never plowed, sowed, mowed, forged, sawn at the sawmill, and turned, and therefore they do not know that the country is not a column of figures in their accounting records. This is such a great "thing" from Chukotka, Kamchatka and Sakhalin, on the one side, to the former Konigsberg, Pilau and other parts of once Prussia, on the other side. This country is people who want to live in it, and not to serve as a field of all kinds of amateurs experiments that carry out tireless digitization, monetization, reforms of this ..of that.. They are all waiting for when and what kind of reform will worsen the state of embezzlers of public funds and improve the situation of the population. Well, for example, will there ever be a reform, as a result of which, finally, roads will be built? Will there ever be a reform, as

³³ **The Human capital** is the number of people with the necessary qualities for self-preservation and reproduction in continuously changing living conditions, and sufficient for the economic development of their territory and its defense. It is the country's power factor, similar to financial capital in significance, importance, and value for its existence.

Book 5. The Complexity and degree of falsity. Chapter 3. To make a lot of steps for the sake of the next one a result of which they will hear what the population say about putting the screws on and tightening the belts on the side of the state, well, at least, in the direction of education and medicine... And it will, believe me, it is already happening, because No One is able to reverse the running processes, even Lord God.



Not today did it begin, but nowadays, the process of destroying life on the Earth reached its apogee. As N. Levashov and A. Khatybov used to say and other people mentioned in my books, a more perfect system than Man, does not exist in the whole of Universe. We are material at the level of chemical elements; we have many other levels of matter organization – etheric, astral, and mental. There is the Spirit (the Soul, the Brain – whatever you like), the structure of consciousness, mind, intellect – and all this fits into a clear evolutionary system. That's why we are so attractive to other worlds. And, of course, there appeared 18000 years ago those who were interested in exploitation of Man as a "deposit", a "mineral". This exploitation had been practically realized by 2012. However, there happened what happened, and now entirely different processes are being developed. These are the processes of restoring (correcting) our Brain to the state in which it had been prior the Ebr invasion. However, auto-motor-like thinking of people still prevails. And especially this concerns the mental activity of individuals of the Brain genotype 4xx, who got a false idea of being "rulers". Being directly dependent on the outside guiding and having lost it at the present day in that form which it had been carried out before, the thinking of these people is devoid of any well-founded nature and is carried out by a random-residual principle – what the Brain retained or was suddenly able to catch from the current transmission, – to that direction it carries them. That's what is going on around us which, on an emotional level, is pushing people to take up arms. There are many who ask an open question: "Well, what is going on?" This question arises immediately in the heads of normal adequate people due to the fact that the situation is such when we feel in

every fibre of our being the enemy before us, but at the same time we acutely understand that this enemy is abstract, invisible, ephemeral. And here in order to combat him, first of all, he has to be seen, in order to look into his eyes. And when this, previously unseen enemy is determined (and he is already determined), he should be laid claims, i.e., specific claims that expose him. It is this, as an example, we are now witnessing in the development of the situation with an increase in the retirement age.

Unexposed enemy will endlessly cause harm, sow the seeds of dissension and anxiety in the society. Exposing the blatant enemy in the disguise of a benefactor, brings to understanding the core of the ongoing events and take measures to prevent the harm. But you have to begin with understanding and make the majority get to understanding of what is happening, and then – participation in the ongoing processes. One of the elements in achieving this (and rather significant, with a proven effectiveness not in words, but in deeds) are **the "SvetL" Programs**.

An important role in cognition is played by the psychology of an individual and human capital. I have already told you a lot about the Programs, the generation processes and the physics of these processes, and the laws they are built on. I have an opportunity to convey to you through these books and articles all my achievements and the information that I have, and then you will have to convey your own understanding to other people who are striving to become Man.

I do understand how much you want to put things in order today with the help of sub-machine guns and grenades, but this is not the method. There is a mechanism of Nature that develops us and that can already be controlled through **the "SvetL" Programs** cognition (and there are many who are already trying to do it) under Man's control. By today quite a lot of knowledge has been gained and systematized, and they are being passed on to those who seek to take **the Bath** and especially those who are already "steaming" in **the Bath**. But it is not so easy to control this process – you have to learn to accept other people with different qualities and lead them – **IT IS THE WAY TO UNITY, to creation of the Human Capital**. However, a careful reader may prick up his ears, because Unity is now widely perceived by many people as a habitual slogan from the past that gathers the proletarians of all countries, pioneers, steelworkers, milkmaids and so on – all in a voluntary – compulsory manner. Similarly, "lead others" – it has a completely stable reflex. As soon as it is required to "lead others" or "follow someone who leads others" – there comes a stable understanding – well, –

"harnessed and settled down again". However, all this has the right to be only after people, endowed with understanding, try to taste freedom – then all this "Unity", "following someone or leading someone" will become possible, but in a fundamentally different form. With no cognition, they are just temporary collective structures entirely, or at best, nearly of a parasitic plan. At least because people do not know another way. They believe that Unity means ... unification? If unification – it means around a leader (personality). If someone is a leader – it means that he has something that looks good for those who are uniting around (money, opportunities, connections, and prospects – in general, some kind of benefits). And if in this construction of benefits there is leader's freedom (the way it looks from the outside and as we could see it in the nineties of the twentieth century), his knowledge, possibilities and the way of thinking, which interested and attracted others, then, as a rule, – it is only a little chance that the people who followed him would choose freedom. The mainstream of them will choose more understandable and habitual "benefits" – the possibilities of the leader next to who it is advantageous to be. And all this, unlikely and theoretically possible, works almost exclusively only if the leader has some fame, popularity and appreciation of the surrounding people of his real opportunities and knowledge. But then the leader himself, as a rule, is not free – he is burdened with the cares of all these associates and appreciators, their problems and needs – this load pulls him somewhere down, attracts to the associates, so that in fact, there will be "Unity" – but with associates living as **PARASITES ON THEIR LEADER**. Well, or somewhat in the opposite way – the leader living as parasite on his surroundings (it depends on the way the Brain genotypes are distributed in the collective- who "leads" and who "are led"). So it turns out that Unity must be somewhat different, not based on the usual relationships, "a donor – a parasite". But we do not know another way – we have this principle in the basis – **"one gives, the other takes"**. But there is such a phenomenon as the need to be in demand, necessary – that is, the need to give something to someone (not to take). If you imagine such a "Unity", the basis of which is **the need to give, be necessary, to bring some benefit** – what will come of it? For the majority, unfortunately, this need (to give) is somewhat specific – **it is "adjusted" to parasitism. We need someone who lives at the expense of what he takes, that is a parasite. Then those who give feel comfortable.** Moreover, there is such **a familiar feeling of gratitude** – it's a heavy, burdensome, everyone tries to get rid of it (in return, to thank with something or somehow). Have you ever thought where

we did it come from? **The 4xx** genotype do not have this burdensome feeling – it is quite natural for them to take. But those who feel like thanking (that is, this feeling of getting something from someone is burdensome) – they are donors. And this is a partial answer to the question: "Do not I belong to this **4xx** genotype?" Of course, people have been made this way, and for them feeling grateful to someone, is abnormal, unnatural – their Brains are arranged like parasites', and for the benefit of their own, react with rejection, tingeing with burdensome gratitude. But as a whole, both are **THE TWO SIDES OF ONE PHENOMENON**, laid in the basis of people's formation and the society of people under that Control System under which we, our parents, grandparents, etc. were born. If we are told: "Strive for unity "- we will immediately get together – donors around parasites – and begin to give them something, complaining of a hard life, but refuse everything that is offered to us, or, if such a case occurs, respond quickly with some good gift. And when we reproach someone: "**You are ungrateful**" – it may just be a command not to deviate from the program given to the Brain and urgently work out the opportunities to organize some benefits in return. And when we feel the need to give / work for someone else, complaining of the universal injustice, – the Brain turns on the basic program of giving the benefits to the 4xx genotypes, thus killing two birds with one stone: **the first** – to give what you have to the specified address, and **the second** – to feel a global injustice in which some people always live at the expense of others, **and humbly bow your heads before such a fate**. Very different variations are possible, but all of them lead to a single result. And all this is "registered" in our heads. I do not know if the standing in the right church will erase all of this (well, probably some fragments that are the most acute in the individual's feelings), and whether there is anything substituting in the



current transmission of the native CS, but the overall picture is quite unambiguous. So, it turns out that "Unity" must be fundamentally different, and in its basis the uniting component can be, so to speak, general development direction similarity (one vector). Based on everything that we have already known, including my books, it will be exactly like that. But the

topical question the answer to which everyone is looking for is "how to make that headway now"? It's very simple – just wait for some strange thoughts, unexpected ideas and other wild extravagances to come into your head, and not try to get rid of them as something that do not correspond to what was discussed at seminars, conferences and other gatherings just because any current union of more or less public character is a dangerous construction because some of the participants' performance of some old programs will initiate a similar one in neighbors according to the herd principle – "...all went and I went..." Perhaps, a meeting on the principle of execution of some new program, but at the same time the old ones are still so powerful brakes that it is possible, while observing the relationships in such a group, to arrange a kind of practical work on "New Knowledge" from N. Levashov, A. Khatybov, and "Fundamentals of Humanity Formation" (FHF) and in other sources. So, whatever you like, **but not by the command, which immediately turns on all the old sub programmed, and most importantly – such familiar and understandable.** The prevailing volume of information that we use today, we apply and assimilate as standards in something and, basically, in understanding; all this is a product of the Brain's activity, grown as part of the development programs of the Interventionist CS. We will turn to this again and again in this book. So you can safely ignore all of this and, throwing out of your head all that hinders, and not wasting time do what you feel meaningful or, in other words – go to **the Bath.**

When Nature chooses some principles for development, ultimately, it chooses and the method of their implementation. Today, the problem of man is that he forms his consciousness far from the principles on which he is to develop in the future, and unfortunately, it is very difficult to overcome. Each man has his own problems, and we must have a clear understanding of this. **It is probably more intelligible to correlate this with the personality psychology directing one's attention to the significant mass accumulated structural data in this area in a certain way.** That's why we will consider a wide range of issues, starting from the psychology of Man, the creation of Human Capital, as the practice in the cognition of human psychology and, especially, his development, and the very physics of all that influenced, influences and will influence these processes, of course, at an angle of **the Technologies and Programs "SvetL"** application, which help the Brain in cognition. Now we will consider the principles of further development of Consciousness. Man should have freedom to choose which way to go, because there will be a great

number of different ways in the world that is being built up now, and the path of transition is the eye of a needle that is to be passed through. The caliber will be very tough – it's easier for a camel to go through it than you know who for.

Once there was such a regulation that a scientist, a researcher, the man who chose the path of cognition, should have been of an encyclopedic knowledge. And today they are pseudo-scientists, because they are all narrow specialists, which are ever growing in number. What kind of human capital can "be made out of them"? Each of them in his narrowness – is not able to anything at all. We have to be (become) "encyclopaedists", otherwise we just **WILL NOT BE COMPLETELY "ASSEMBLED" SUBJECTS** of this world, and Nature with the processes fit in it can not permit it. **THE NECESSITY TO BE (BECOME) AN "ENCYCLOPEDIST"** is a vital regulation! Only in this way can you create what is called Human Capital.

3.2. The idea implementation

At the basis of what we understand as education, there must be a certain worldview paradigm or, as it was customary to say quite recently, an ideology that solved the relationship problems between Nature and Society. But what should replace the Marxist scheme on which three quarters of the century there relied on any education, including (first of all), humanitarian, that is, in fact, the education that my generation got, and those who studied in the 80-90ies of the past century? This problem is not only difficult – it is extremely important for any man, and especially for those who are trying to find answers to truly new questions of the relationship between man and Nature. However, I am deeply convinced that in fact this problem is much profounder. Mankind faces the need to revise the profoundest foundations of its worldview, comprehension of its place in Nature, its relationship with others – revising its civilization paradigm. Hence, this question, posed by people in their quest to cognize, goes far beyond purely university educational subjects.

I am trying to suggest only a certain position, developed on the basis of my own knowledge, because, in my opinion, the answer to the question posed can only be found in a deep creative discussion among people of different profiles in cognition and ... time! I want to put the question even wider. Today is a turning point when, in the history of our civilization,

natural restrictions intrude into life itself, and new ideological directions become a social necessity. If man does not find the right key in his relationship with Nature, in the knowledge of Nature, he is doomed (though I note here that this is the choice of everyone), whatever there can be the politics, democracy, state structure, desires and aspirations of the powerful of the world. And with the affirmation of this principle in the mind of man, as I think, the general philosophy and worldview in the upbringing of people should begin. Rather, not quite upbringing, but the possibility to expand man's worldview independently, taking into account the psychology of the people who turned out to be participants in such a complicated process of transformations of everyone and everything. This worldview should replace the traditional "scientific and the only correct ..." If the initial principle of the necessity to find one's place in Nature and one's strategy in its relationships with people will be mastered and comprehended, then everything will fall into its place. After reading the works of N. Levashov, A. Khatybov, and the works of other great thinkers, including, of course, the basic work **"Foundations of Mankind Formation"**, which I appreciate very much, all this "naturally correct" is already **TAKEN IN NOT AS DOGMA**, but as answers to the vital questions of the present and the future. You can agree or disagree with them, but you already have a serious basis for discussion. There are many who advise me to simplify the explanations and the texts I use, since they are very difficult to be grasped for many people. I am doing it, clearly understanding the information I provide in my books. But to simplify the real text is fraught, – especially for those who may use this information, having known it in a simplified way. We know from history many examples of how the originals were interpreted and "presented" in some completely different foreshortened of their authenticity. But then it was done with certain and definite goals. This is also done widely today with the aim just "to drown people in information", in the mass of which they are not able to make out anything. I decided to make my "simplification" based on those processes of cognition, which are described and explained by the authors respected by me in the context of certain vital conditions and events that are necessary today, commenting upon with my explanations. I do not see any other way of explaining the readers' emerging questions, and, of course, I hope that everything written by me will motivate people right now to turn **to the "SvetL" Programs** for help, understanding them and everything that happens around independently, and not with all sorts of "helpers", spiteful critics, experts and "heirs", who the way to **the Bath** is closed for.

Today's scientists have their own standards of thought, their manner of expression, their language, sometimes an insurmountable obstacle for the "uninitiated". In addition, there are also certain motives for the direction of analysis, which are not always intelligible for non-specialist. Therefore, to invade this unusual environment, there should not be a superficial understanding, but rather weighty arguments and grounds. And no matter how subjective these goals could be, the presentation of the corresponding system of views turns out to be really justified, since only in the discussions on issues that arise in the intellectual, moral and spiritual spheres, people **CAN COME UP WITH A NEW PARADIGM OF WORLD OUTLOOK**, which is very vital today, in my deep conviction. And this statement is not just a "beautiful phrase". I'll try to substantiate it. There are many who are already beginning to realize with some inner feeling that society is on the verge of a catastrophe that will bring about the restructuring of all the foundations of its planetary existence. Occasional discussions in academic and worldly circles of the ever growing troubles are still far from revealing the depth of what is happening, and even less able to offer any alternative, mainly getting information from the Internet and the media, and the point of which is nothing but emotional discussions.

Nobody has yet publicly ventured to demonstrate the real truth (although there are many who are already suspecting about it) in all its naked unattractiveness, and we only come to understanding that humanity has already exhausted the potential of its development that it had got at the end of the previous stage of its so-called "development", of which much has been said and will be said more. I will also note, and it is important – philosophers, psychologists and just people who are striving to know, are engaged in the problems what already belong to the consciousness, what should be attributed to the objective, and what subjective perception is. But what place the information process takes in the world evolutionary process, and even more so, what the term "information" mean – such questions remain aside. And this is fundamentally wrong. Therefore, I am trying to convey the truth of current developments and processes.



The Earth itself is recreating all its true states and carries out the liquidation of the consequences of the intervention in its Civilization development. But the main thing against this backdrop, probably, is the re-creation of the Human being, with his primary true functional endowment: to form his true Mind as the key basis of the Earth Mind.

3.3. Leaving the void

I am perfectly aware that my explanations regarding the Brain genotypes are not so much entertaining to many of you as Alla Pugacheva's losing weight. We become direct witnesses of the destruction of the old type of information delivery (through the media, completely incompetent politicians and reporters, corrupt journalists and Doctors (**Doka**³⁴ **TORA(h)**) Of course, in the near future these vices of society will remain, but respectable publications have begun to come out, – but, mainly people who are careful about what they are saying, so they are just for the thinking majority. For the rest – the yellow press in a latrine, where there is every opportunity to demonstrate one's mental development to the toilet bowl. We see a good Russian acting school and meaningful performances that make us think, and hear our native Russian songs performed by talented singers. Despite everything, education is changing, since the so-called "challenges of time" will not allow us to be backward tribes.

To begin to understand and, most importantly, to analyze the information provided in this book, one should take into account the fact that after changing the control system (2011.04.24) the very process of cognition **MADE A QUALITATIVE TRANSITION** from the materialistic methodology of the truth cognition to **materialistic idealism (idealism-materialism-materialistic idealism)**. This was preceded by a number of changes in the Brains of people, and through this – the level of the true knowledge about the world in which people have been living. The methodology of materialistic idealism is based on energy-information dialectics and has a clear materialistic basis – the presence of primary matter of all existing. This matter is given to us in sensations through the information entering the Brain about the world around us, not only through the senses (otherwise it is materialism). The presence of these **PRIMARY**

³⁴ **Interpreter; he who is well-versed** or skilled in any field.

MATTERS AS ALL EXISTING has been theoretically substantiated by our Russian scientists *N. Levashov, A. Khatybov, A. Luchin*, thus symbolizing transition to cognition with a new interpretation and a different methodological approach – ***the methodology of the dialectics of energy-information development of the energies being control.***

Dialectical materialism, as a materialistic basis in science, has neither explained nor substantiated in life practice "natural", i.e. historical regularity of globalization manifestation. With the help of what and how can one explain the existence of the very fact of the myth imposed on the entire world community about its "just" inevitability and its only usefulness for the world "and to prove that it is not a natural regularity?"

Without relying on the limited methodology of materialistic dialectics, in the basis of our research, in the course of the narrative, we are laying ***a completely different methodology of energy-information dialectics*** **OF STAGE BY STAGE DEVELOPMENT OF GENOTYPES** – with different understanding of all processes in the history of the Earth people. It corresponds to the present stage of materialistic idealism – it is true, close to the truth and will ensure bringing out the first cause of everything happened before. In order to move forward we have to determine the true concepts relating to globalization, psychology of people, and on this basis – of Human Capital, from the point of view of *energy-information dialectics* of the **STAGE BY STAGE DEVELOPMENT OF THE BRAIN GENOTYPES.**

It is necessary to understand their current state taking as a starting point understanding of those lies (not only historical) our ancestors and we have lived up to now, and also try to become aware that "***all these are lies from the first to the last word***", and against this backdrop we have to see the sphere of the forthcoming changes dictated by the future phenomena, actions and events. **THERE ARE TWO KINDS OF VOID:** the one which you left, and the one which came up to you. The choice is always yours, readers.

3.4. Superiority illusions

Strategic psychology. The first conception of it came into being under the influence of global changes in the world, including the psychology of citizens and their leaders in the framework of the program of the Brain

genotype evolution in its final stage. New times are characterized with globalization known to all from the works of the mondialists³⁵ J. Attali, F. Fukuyama, R. Robertson, Manuel Castells, and others. The points of view of Russian researchers are diverse, indifferent to the fate of Russia and today's serious concern about the events development in the process of globalization. Of particular importance are the points of view of M.G. Delyagin, A.S. Panarin, M.V. Il'in, S.P. Kapitsa, V. Yu. Katasonov, and other specialists; and strange enough, – representatives of the Church and the Armed Forces of the Russian Federation. In either event, globalization is known as the embodiment of the idea, in accordance with which all states and peoples will merge into **"A SINGLE PLANETARY FORMATION"**. Ethnic, national, religious and cultural boundaries, which are a stumbling block, are to disappear. All these are the plans of those who imagined themselves as "rulers of all and everything". So what is meant by globalization from the point of view of energy-information dialectics in the Brain genotypes evolution stages? **"Globalization"** is the **FORMER EXECUTIVE PROGRAMMED PROCESS** of the stage of civilization development under the control of ***the old Interventionist System*** and the formally declared generalization of the basic views of the ruling class of the Anglo-American-European minority (supposedly the global ruler of all development processes) within the framework of the actions and events organized for their part on the global level, built on the secret doctrine of the "Anglo-American-European illusion of their some kind of ***civilization superiority***" as an insignificant minority in relation to the overwhelming majority of the rest peoples of the world. The states were built on the same principle, – as an element of the control over people living on the territories designated as states, and as a complete system of life-support and security of the insignificant minority in relation to the overwhelming majority of the people in that state. By the same formula and within the framework of this design, the so-called "Roman law" was created, which has been used in full up to this day.

Globalization is the division of the whole System ***into two independent structures***. Within the **SINGLE PYRAMID** we have:

³⁵ **Mondialism** (from the Latin. "Mundus", fr. "Monde" – "world") – a project to establish a world government, Mondialism – the English version of the French word "mondialization" . Sometimes this concept is confused with the phenomenon of globalization. **The concept of globalization** relates to the economic sphere of human activity, while **mondialization refers to civil and political**.

1. The closed upper part of **the pyramid**, the information on the existence of which is to be given in the form of legends. The whole multicolored veil, as a legend in the orientation of development through various ideas, proclaimed programs, "discoveries" and so on, was just people developing Brain's distraction from the comprehension of the truth of the ongoing processes. This legend is concentrated by its distracting attention on various "efforts" to change social structures and forms of the control through forced and compulsory violence, everyday, consumer, entertaining and spiritual orientation.

2. Production structures, or **States**. Particular attention is given to defense and law enforcement structures, which have to not only provide the necessary completion of the upper pyramid, but also suppress any attempts to resistance. The number of states can not be more than the number of objects providing them. At the same time, the top pyramid is one, and some presidents may not be permitted to rule.

Anglo-American-European civilization superiority:

- this is only a partially completed product of the executive activities of some people who have been subjected to the formation of the distorted and deviated from the truth consciousness through their violent involvement in the interventionist programmed control process – ***"Development of the Brain Genotypes";***

- this is the main part of the overall executive state, as the final part of the target programmed process (presented to people as a certain program of civilization development – "Globalization") of the Interventionist Control System for the implementation of ***"the Civilization of Parasitism and Violence"*** on the Earth.



At one time, globalization was thought to be a product of the "egg headed" mind from the "think tanks" of the United States: the Council for Foreign Relations (**CFR**), **RAND** Corporation, the Center for Strategic and International Studies (**CSIS**), the Office of Psychological Strategy – they most often quote a large-scale project "**Prospects for America**" created in the mid-fifties with the participation of Henry Kissinger, Dean Rusk, Adolf Berle, and others, where the theoretical regulations of increasing interdependence of all countries and regions in the world, the decline of the national- state forms of power, broad interpretation of problems were set forth. Not without their participation, among other things, there was organized the appearance of the very fact of the anti-civilization conspiracy of the international oligarchy – "Globalization" – a **SMALL GROUP OF THE RULING CLAN OF IMPOSTORS'** formations and individuals parasitizing the entire world community, and much more. ***They constitute slightly less than 1% of the total population of the planet.*** Representatives of this minority have taken root in all countries of the world, they continue to parasitize everywhere with less destructive effect and influence, but with much greater destructive aggression performed by someone else's hands! This is the artificially imposed Anglo-American-European illusion of the historical inevitability of their civilization superiority. However, after the phenomenal insolence and thoughtfulness of the historic ***September 11, 2001*** attack on the symbol of the world's monetary and market structure, – the two World Trade Center buildings in New York, it became clear to many people that the previous violent, and sometimes bloody, disputes between the left and the right – is the distant periphery of the real changes taking place in the world. A completely different meaning is now attached to history, culture, and ethnos in a new planetary state, which were understood as derivatives of the market and democracy. In what way the world will unite in a rationally functioning "machine" – to imagine it at the level of our current development is very difficult, but to strive for this, is, of course, necessary. It is only obvious that globalization is a certain process, a series of empirically fixed changes, heterogeneous, but united by the logic of the world's transformation into a single whole, is proceeding independently of the expectations of its supporters and the protests of its opponents. But what do the antiglobalists (globalists) try to achieve in their auto-motor-like actions? The state remains, colors and flags are preserved; presidents' physiognomies will often appear in production workshops and farms, as before. True, there is one "but": -the distribution of all the riches will be done by the specialists from

the upper pyramid; in the lack of the concept of "substitute", only the representatives of the upper pyramid will manage the finances, the population will use money of the simplified format introduced specifically for them. There is no need to develop science in every single country – it is enough to have diversions at the level of rationalization proposals ("Na-Na" technologies) to ensure production. Science can only be controlled by Mochiach and his executors, who have (should have) a communication channel for the Programmed Modifications. Globalization envisaged the population reduction by more than 88%, while considering not the current state of the official, but his Brain, since the Pithecanthropus' brain does not suit the Control System anymore. A new form of political power is being created (in our today's understanding it is created with difficulties), which instruments will be:

1. information globalization (virtualization),
2. economic globalization (innovation),
3. regional globalization (the world without borders),
4. demographic globalization (the main resource).

In the strategic psychology conception, ***globalization is a global psychological change in the picture of the world, the worldview of people, in their life position and in their way of life.*** They are the subject of research and correction of strategic psychology. But the subject of strategic psychology is at the end of a very complex chain of scientific concepts that are not considered in psychological science today.

The ideology point of the interventionists' conceptual power was in the Target Vector, framed with the following target frames: "From the individual disintegration to concentrated conciliarism", the establishment of a complete diktat over the planet's natural resources and the mandatory, the only introduced form of integration-World Market Exchange. The whole process of implementing the conceived ***“From the individual disintegration to Concentrated conciliarism”*** embraced a fairly long "historical" period and ***had been completed by 2000*** with the formation of the so-called ***"Golden Billion"***, i.e. "conciliarism" has been realized. The symbolizing programmed process of this was the program of "Globalization". The entire process of civilizing development on our planet was carried out by the old control system in three completely isolated from one another by their Target Vectors (phenomena, actions and events) of the civilizing ways of life. Ultimately, in line with the plans of the old Control System, **by December 2012**, the being prepared inconsistency of the civilizing ways of life of all

three Target Vectors, would have come together on a single field of battle – the former territory of the USSR, by that time necessarily having lost all sovereign independence and some sort of self- or state security due to the final collapse of the Communist type of civilization. In this field of battle, it was to take place the formation of the future program hierarchy of the Global Control with strict subordination of civilizing ways of life with the rigid administrative basis of the established programmed hierarchy of individuals separation according to the Brain genotypes (as some public authors call it: ***the international "Conspiracy of the Globalized Elite for Establishing total planetary slavery"***, or the "Golden Million" program – is no longer important); and the liquidation processes of unnecessary peoples on the planetary scale were to be initiated. By the way, the phenomenon point of the Conceptual Power was embodied in the predictions of Nostradamus, which was chosen by the system as a contactor. He just translated and voiced the programs of the Interventionist system.

Globalization proceeds from the program of cosmopolitanism. Cosmopolitanism, as a strategy, was introduced as the most important point of the 100-year Program in 1888. Let me remind you that the program of cosmopolitanism had the following goals:

1. Establishment of a unified financial control.
2. Establishment of a single ideology for all Brain genotypes 421 (Ararat), 441 (Mont Blanc, Alps) and a unified system of information perception by creating legends, "archaeological" wonders, annihilation of all structures and bearers of a different ideology, which continues to this day and before our eyes.
3. Development and creation of a single mechanism of the society control, approbation of technologies to control the societies – capitalism, fascism, democracy, liberal democracy, socialism, etc.
4. Ensuring control over all raw materials.
5. Preparation of conditions for the arrival of the Ruler of the Earth (Mochiach). In the process of the Cosmopolitan program implementation, representatives of the Brain genotypes 421 and 441 got all necessary information from the Control Systems and implemented it using the developments of various Masonic orders assembled together with the consideration of the Program requirements in "The Protocols of the Elders of Zion".

The Protocols themselves are not even a Program, rather they are wishes, but they reveal the essence of cosmopolitanism by more than 33%.

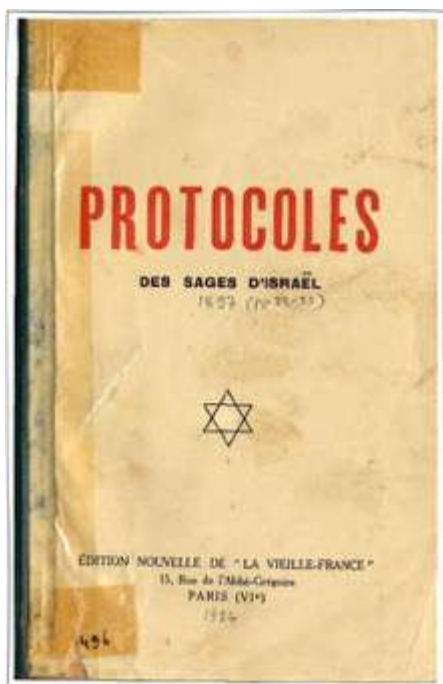

All the points of the Program on cosmopolitanism were fulfilled and smoothly passed to the next stage of this program – Globalization, within the framework of which the role of the state is strengthened.

The civilizing picture of the World today is more than ever contradictory. The truth of the current changes in the life of the world community is more catastrophic than the mild statement about its contradictory nature. A false demonstration of its "seemingly successful implementation" is in fact excessively filled with the illusions of the non-existent well-being and purity of people's being. Automatically fading

"Globalization", as the former executive program process of the stage of **civilizing development** under the control of the old Interventionist System, and the formally declared commonality of the basic views of the ruling class of the Anglo-American-European minority (supposedly the World Ruler of all development processes) within the framework of actions organized on their part and events at the global level, often seriously disagree in their non-public assessment of all that is happening. Only one thing is convincing in their circles: their unity manifests its granite monolith at such moments when it is required to "irrefutably justify" in the framework of the legal field imposed by them and justify the violence and militant aggression used by them to protect their parasitic interests as an insignificant minority over the socially limited majority over which they are losing their power.

In the especially intricate illusions of "civilizing development" and the imposed falsehoods about "universal well-being", the effectiveness of any kind of the control of the world community, the societies of individual states, the life organization, and rather, the existence in any sphere of the planet's people being, is no longer possible. The world is collapsing at an accelerating pace! The entire previously created and established structure of the organized and controlled life of people, of the entire world community is being destroyed, and this allows us to say that "some kind of global secret project" of civilizing collapse supposedly is being realized" through the intensification of violence and social parasitism of different scales. In fact, this is not a secret project, as the contemporary publicists try to see it, but **a systemic impact on the elimination of the created and realized old Construction of the violent and parasitic being of an**

insignificant minority with the transition to a different form of being organization that excludes all the previously imposed negative, emphasized by the new Construction – Mankind (Humanity) with other goals and mechanisms for their achievement.

A specific question arises: who does the World owe to all this "vicious perfection" leading to an imminent and irreversible death of the entire world community? Why has the world come to the state of **"Inferno aggression – All against all"**? This question is related to the objective **BRINGING OUT OF THE INVESTED PROGRAMMED EVIL** into the very root of all the executing actions of people and the control of their past and, partly, their current being, representing in general a whole developing system of the **"Civilization of Violence and Parasitism"**. And the answer is objectively obvious; it is demonstrated by the entire historical final of the accomplished programmed collusion built on the secret doctrine of the **"Anglo-American-European illusion"** about their certain civilizing "superiority". This accounts for the presence of the very fact of the systemic collapse of the civilizing development of the whole planet society at its current stage, as well as the demonstration of the true causality in the formation of the unconditional need for the transition to a different way of development and the establishment of a new World Order, in particular. This also explains everything that people see and observe around themselves in the actions and decisions of the "ruling elite", churchmen and all those who persistently try to impose their own "opinion" reproduced by their fevered Brain – rather than the realities.

I am absolutely convinced and I know by virtue of the information I get that within the next 20-30 years (and this is an instant in real life) "the modern, imposed on us history, will be razed to the ground, and history itself as a child of the **Jewish Torah**, will go to the section of mythology as a reminder to the people about the times of obscurantism. So it turns out that we are living now in their last days, but unfortunately, most people do not find the substantiation for the happening, but it is not their fault. You see that the tenacity of the liars - "rulers", their all kinds of providers, and serving them religions is astonishing.

Quite recently I read, and then I myself got convinced that in one of our Russian shopping centers the ROC clergy opened a church. I find it difficult even to characterize this action, because Christ in his time expelled traders from the temple, and this is a well known story. But I can not make it out what to do with the temple at the bazaar. Logically, it is necessary to

expel the temple or destroy the bazaar around the temple, ***because these organizations are incompatible.*** This kind of things is happening before the eyes of people, and for some reason people take it for granted ... Here you have the realities against the backdrop of ignorance and lack of common sense of the initiators of the action, but with the greater "meaning" of what they conceived.



3.5. The programmed "selectivity"

The World Order organized by the invaders, the constructive form of social injustice that they have introduced throughout the world and in all civilized ways of life on the basis of their falsely "necessary" and allegedly compulsory "superiority and predominance" in all the vital foundations of the world community (as an insignificant minority), and moreover, with the help of violence and parasitism over the overwhelming majority, ***all of this together has no basis for further existence in the society life in general.*** And I want to emphasize that all this have to be **NOT REFORMED, BUT LIQUIDATED** to the ground without any residual elements of a temporary or long-term nature, replaced by a fundamentally

new constructive arrangement of the world community **ON A DIFFERENT BASIS EXCLUDING VIOLENCE** and former parasitism, and not only on the level of unresolved problems of social justice, but in all spheres of the newly formed reasonable being of all people, and more precisely – Mankind. So what is the idea of this so-called artificially imposed "civilized advantage"? And the idea is not in its really "worthy level of civilized development", but in the **IMPOSING AT THE CONCEPTUAL LEVEL**³⁶ the illusory information of a governing character for organizing the existence and material life of the world community as a certain basis for the step by step formation of certain target frames of a separated world outlook among people, depending on the Brain genotype, a specially oriented individual and public consciousness. But everything was built in the framework of violence and parasitism and with the finally entrenched elements of the control through tough parasitism and violence irreversibly imposed by the triune fascism, which we have already mentioned, finally manifested by the individuals of the Brain genotype 46 (with the whole set of its sub genotypes) as a conventional "Golden million".

On the basis of the energy-information dialectics of the Brain genotypes development, there is a true explanation for all so-called written history and the programmed "selectivity" of the specific so-called personalities, through which all the elements of violence were realized, imposed and taken root, and also the so-called historical elements and justifications of this violence of the old "false-truth". The very essence of the Interventionist system program "Energy-information-Dialectics of the Brain genotypes development" gave to our world with no will of people and not as a result of a "natural and logical civilized process", **BY THE WILL "FROM OUTSIDE"** this "product" – individuals with **the Brain genotypes 42-46** as an artificially created level of the only acceptable "executors" for the Interventionist Control System. This specially created level of "executors" was prepared by a certain correction in their Brain construction in order to give some of its functions such special states that could provide reception and execution of the transmitted system information of cognitive and control character, strictly identified and oriented to the formation of the given individual and public consciousness, **EXECUTION OF ONLY PROGRAMMED ACTIONS** is necessary for the actions and subsequent events organization, characterizing these individuals as completely

³⁶ **Conceptual level** – All aspects related to the interpretation of information and the manipulation by the information on a problem area or spirit space in the information system.

reasonable and independent. Such a state of programmed "selectivity" of a separate numerous group of individuals was an act of violence over the very essence of the true Man's mission on the Earth, giving Man, a material-thing-like state in his entire life being. And the main thing for us now is to distance ourselves from everyday emotions, and to understand once and for ever that in these deeds "from the outside" **THERE IS NO PEOPLE'S FAULT FOR ALL THAT WAS DONE BY THEM IN THE PAST**, as they, people, were just too weak against such a Systemic domination.

Nevertheless, the raised programmed "selectivity" (and from 1914 to 1995 *it was quantitatively brought to the level of 22% of the total population of the planet*), by its actions fully ensured step by step civilized development within the framework of the Ebr programs. But this Control System no longer exists. The Control System introduced on our planet through intervention from outside has been completely destroyed. From **2013.12.31 (23.15) to 2014.01.19 (01.15)** the Control Program of "Violence and parasitism" was completely destroyed at the Main object (type 960, Moscow) and objects of its "escort", i.e. objects of type 520 and 500 Moscow State University, Mnevniky, Ilyinka 6, Tsaritsyno, Zhukov Avenue in Moscow), which I have already mentioned in the previous books. Through this program, during the whole time of the invaders Control, there was carried out all the tragically created on the Earth "civilized development» on the basis of violence and parasitism. And now it is especially important to understand that from that moment there began the destruction and elimination of the entire previously formed system of violence all over the planet. Of course, this is **ONLY AN EPISODE OF THE CHANGE**, and to achieve the visible effect of its practical results, it requires a certain time, going through the events created through people and involving people. The time factor dominates and, unlike our desire "immediately and today", the implementation will take more than one year, but the main thing is that the processes are already initiated, started up, and this is irreversible.

3.6. At one's wits end

Our future depends only on our understanding of the current events, for which we have to get rid of the illusions imposed on us by those who no longer understands anything in the ongoing. Reasoning and thinking were not allowed to people – this was counteracted by the old System in the framework of its Program through the most complicated structure of the

Conceptual Power. It basically provided a "figurative behavioral" form of existence of people who were in a purely "material-object-applied" state of their passive life and, accordingly, had extremely limited frames of "free" reasoning of both the mind and the intellect capable only of minor step-by-step solutions individually or in the community.

The intellect is related to practical activity, it is capable of making mistakes, it is dependent, it is designed for other abilities, is their instrument for achieving various goals. It does not have tasks of its own and therefore is idle and gets weak while inactive. **THE INTELLECT IS FED WITH KNOWLEDGE.** Knowledge occurs for the reason limited by the simple awareness that an object exists. The intellect is limited to those indications and forms, which are intelligible for the senses. Knowledge is fragmentary, incoherent; it does not link various phenomena into a single whole, indissolubly cemented by an inner causation. Everything is accidental and inexplicable in knowledge. The intellect's evolution occurred in strict dependence on the temporal development of the specific Brain genotypes. Knowledge grew through the simple addition of one knowledge to others. Each gained knowledge was closed in itself and did not trigger off new knowledge, it was limited to outer indications and forms, but not by the intrinsic nature of the being cognized phenomenon. All these key moments I tried to "correct" through *the "SvetL" Programs*, proceeding from the fact that the knowledge that became available in recent times, is increasingly different from the knowledge that was given before.

The Mind, on the other hand, is related to the theoretical activity, it is something closed and deeply independent. Not man (the Brain) possesses It, but It lives in man, subduing his will and desire, but not obeying him. In itself, the Mind has its purpose and makes us forget about all the needs, rather than serve them. Outward activity depresses it. And this task is solved in the Programs through understanding, which is consistent with the goal. The Brain is "prompted" through an understanding that reveals what lies beneath outer objects and forms that produces them. The purpose of understanding now is to comprehend individual phenomena in their interrelation, to understand the whole, the parts of which constitute this phenomenon. In the process of understanding, everything necessary becomes clear. Understanding is being perfected, getting deeper and more complete. The truths are united only in understanding. Understanding begins to shape with the dominant participation of the human mind, and then the senses are only tools for it. The Mind is different in different people, and their understanding differs to some extent, even with the use of the

"SvetL" Programs. Against this background psychology has to try to foresee its new horizons, too: it lacks this so far, but it certainly will get it. The Mind Cognizes, giving rise to this process, opens the "door" to the "arbitrariness" of similar concepts, filled with some other meaning, justifying the evil that is done under their cover. Human behavior in human society is now easily led aside to false ideas using "the Mind" and "reasonable". All knowledge originates from the Mind. Unfortunately, with the use of the concepts "the Mind", "reasonable" in the context of human behavior in human society, at the present time there is complete arbitrariness.

For the last 18,000 years, there has been one civilization, and it is only divided into the stages of changing interventionist conditions of the control and the corresponding imposed states of the general stage-by-stage **UNNATURAL BEING**



OF PLANET Earth from the time of its capture up to now, as the program of "development", not connected by its essence with the true mission of the Earth in general. Transformation of psychology for such time scales is best called psychocenos³⁷, by the definition of my friend and the man, who gave me much in politics and cognition, A.Yuriev. The dynamics of long waves of psychocenos or, more precisely, the embodiment of the targets vectors of specific events within the framework of the control Ebr system, is shown in the known historical facts and indicates which leading psychological mechanisms were relied and carried on in the course of different historical events. In time, the whole direction of psychological science was replaced by one another. Alexander Ivanovich even before the publicity of the "Foundations of Mankind Formation" suggested the presence of "waves" of four types ***with a period of 700 years:***

1. waves of psychocenos, conditioned upon the dominance of interest in **volitional processes**, and the use of **psychological coercive techniques** in politics (**400, 1100, 1800**);
2. waves of psychocenos, based on psychology of unconscious, and the use of the method of suggestion in politics (the highest points – 540, 1240, 1940);

³⁷ **Psychocenos** – a group of people with different, often with hardly compatible psychological properties, peculiarities, status that make up a political society (**A.I. Yuriev**)

3. waves of psychocenosis with the dominance of the psychology of faith and the mass use of persuasion through coercion in politics (the highest points are 650, 1380, 2011);
4. waves of psychocenosis with the predominance of the psychology of the Mind and the use of evidence in politics (maximums of 150, 820, 1520, 20 ...).

The fourth point is quite acceptable in our time and in the future. However, the true reasons for the embodied expression of specific stages in the civilization development are **ONLY THE STAGES OF THE BRAIN GENOTYPES DEVELOPMENT** as an externally controlled process realized through Complexes and Objects.

There was carried out a strictly regulated by the external intervention the development program of quite specific Brain genotypes in 12 stages (this was presented as 12 generic Tribes) for almost 18000 years. It was carefully concealed that the Man has also

the Mind, and it has a specific construction, which the Ebr System tried to "deform" in various ways. *Each individual typology of deformation of the Mind Construction is the so-called Brain Genotype.*

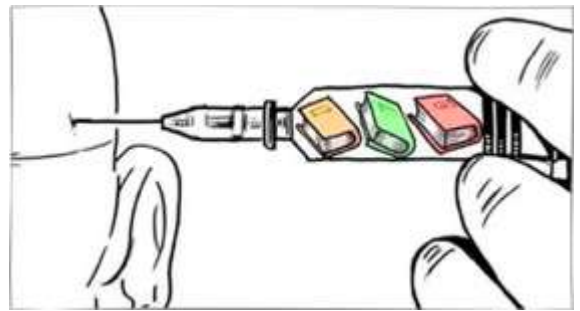

Through the construction of the Mind, which is just "deformed" by materialists at present, a contact information state is gained – Consciousness. And it, Consciousness, has completely different capabilities, unlike those attributed to it by the present philosophy and medicine. Why? Well, because the parameters of the executive step-by-step processes from the programs on the *"Development of the Brain Genotypes and Energobiogenesis of the Flesh Cell"* were laid in the basis of each stage of development. The entire history, as the program for the development of the Brain genotypes, is The Basic Law of History, and not anything else. This is evident from the fundamentally new philosophical approach to the stages of the human civilization development – the **METHODOLOGY of ENERGY INFORMATION-DIALECTICS**, corresponding to the present stage of materialistic idealism. And since the life of people, in all its essence and nature as such, is the **CONSEQUENTIAL RESULT OF THE IMPACT OF GOVERNING INFORMATION**, which in turn is the target contact control process with the substance of the state of the Mind, then the

stages of the information development are exactly the stages of people's life development with all the relevant stages of their life events. This allows us to express the only true conclusion: The "hexagonal" formational approach of the modern theoretical basis of social science, as the erroneous wheel of history: **primitive communal, slaveholding, feudal, capitalist, communist and democratic systems**. And then – the abyss, the continuation of the next stage of eternally developing something like "to the ground, and then....." and again only through violence? **IT IS A TOTAL SCIENTIFIC ERROR** that has ceased to exist since the destruction of the Ebr Mind state substance. Of course, the waves of psychocenosis, which A. I. Yuriev defined in his research, is an awareness very close to the actual processes that are taking place, but the true stages of the civilized development of people and their communities were:

- ***"The Pre-Digital Information Civilization of Human Development"* (until 822 BC)**, which was realized in two historical steps, namely: **until 1605 BC. and after** (the entire control process was carried out with the help of energy information, which **WAS BUILT ON A NON-DIGITAL BASIS**);

- ***"Digital Information Civilization of Human Development"* (from 822 BC to 2010)**, which was carried out in several steps, divided by the processes of the step-by-step introduction of the Brain genotypes from **422 to 461 inclusive** (constructive structure of all energies of the control information **in 882 BC** was transferred to a digital basis, "brought" as a purely Interventionist one.

Since **April 24, 2011**, as it was mentioned, a new process has started entirely based on other principles of information construction of cognitive, governing and supporting character; and also there carried out changes and transfer to higher octaves of a different state of the Brain. A new era has begun: ***"The Information and Genetic Civilization of Man."*** In this regard, all the legends about the development of supposedly some kind of the fourth Civilization on the Earth are not true and is an auto-motor-like intention being realized through people transforming their Consciousness with the built-in (auto-motor-like) intention (on the part of the Interventionist Ebr System). Why do I write in such detail, constantly coming back to this? Well,, only because there is nothing yet that could make these processes "easier" for the Brains of people, unfortunately, except for ***the "SvetL" Programs***. This is an objectively verified reality. But I know that in the very near future new technologies of a more extended nature will

appear in this direction – the work on this does not stop, because nowadays, the center of gravity of psychology, which we began to talk about in this chapter, **HAS SHIFTED TO THE PSYCHOLOGY OF AN INDIVIDUAL**, to resolution of contradictions of "an individual and society", "freedom and necessity", "duty and right". You can see it and observe in your daily life.

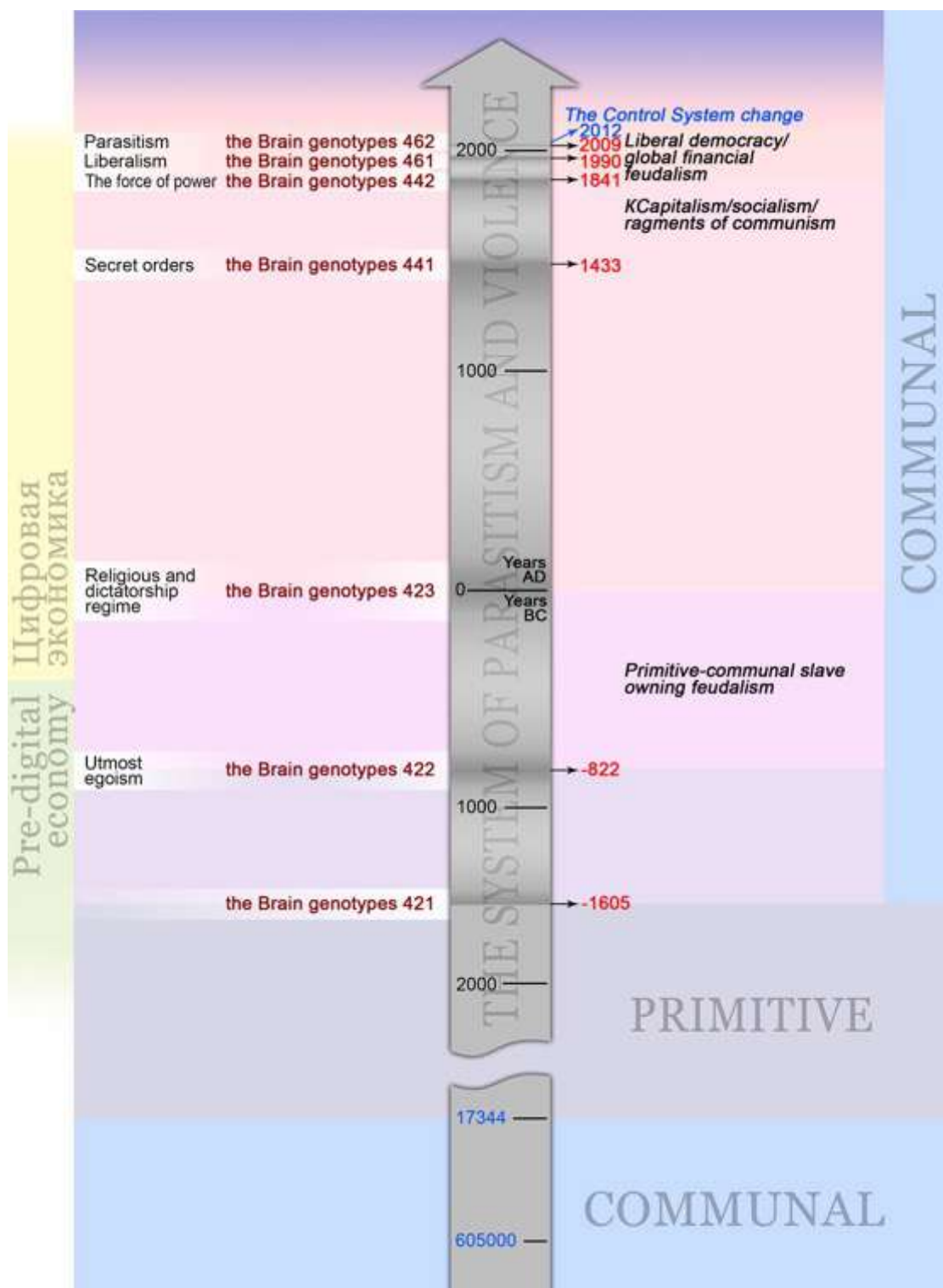

3.7. Humiliated state

Since the beginning of the nineties of the last century in the internal state way of life bloodless but tough struggle of the weakening, and previously universally recognized philosophy of life and the existence of people with the disintegrating traditional practice of arranging all spheres of life has been under way. There has been an encroachment on the cultural, spiritual, social, public and many other foundations, principles and norms of the earlier achieved level of the civilized development, including the states and elements of the gained social consciousness and the accepted traditional concepts of the values, importance, fairness, and the forbidden, etc. The whole methodology of values undergoes a tough impact on the side of the residual automaticity of the parasitic System; the former foundations of the private, family, public, religious and political life of people are being destroyed. The reason for this is domination in Russia at the end of the 20th century of people, many of whom are far from the high standards of human sciences. But we already understand – probably, there could not have been another way. Recently people who are not burdened with fundamental knowledge, outstanding talents and achievements in work have become the standard of prosperity. At the same time, people with the highest parameters of thinking, memory, attention, imagination, have been pushed to the periphery of the society's life. Educated, intelligent and creative people either leave the country, or go into the realm of primitive occupations, or drag out a miserable existence. It is not uncommon when a laureate of the State Prize for exploration of the Cosmos rummage at night in one rubbish bin, and the best in the country specialist in the science methodology picks up used bottles on the other.



Naturally, a lot of people are already having a question that does not have a direct answer: why did this happen? It happened – because parasitism was an indispensable condition for the existence and functioning of the Interventionist Ebr system. ***This made it possible*** for the **GROUP OF INSIGNIFICANT MINORITY** *to arrange with impunity all spheres of their life in such a way so that the overwhelming majority turned into a resigned submissive state before them*, almost voluntarily agreeing to its humiliated existence up to the level of the limited survival under the conditions of complete injustice and all-round social parasitism at the expense of the unbearable conditions of existence imposed on them, but for the sake of prosperity and the wild material excesses of an insignificant minority, which for this, manifests even more sophisticated forms of violence. All this is completely contrary to the fact that Man is recognized by the materialistic teachings of this non-significant minority as a rational being. And against this background, for a number of historical reasons, the domestic psychological science actively developed only one of the four directions determining human behavior. This direction is called **psychology of the Mind**, as V.G. Leibniz and others named it. Three other directions are either not fully known (**psychology of the unconscious**), or are not popular (**psychology of will**), or completely farmed out to adjacent disciplines (**psychology of faith**). However, man in the struggle for existence, above all, is a "multi-eventer" – effective behavior worthy of Man, is possible only if there is the Mind (and Consciousness), and Faith, and Will. And in most historical circumstances, as we can see it, the decisive point for "success" belonged to one of the three directions of psychology, little known today to our contemporaries. It apparently, turned out this way because the civilization in the twentieth century developed according to the laws of the "commercial project", which may be correct or erroneous, and not according to the laws of the evolution theory, as many would like to think. But we already know that the Civilization that has been implemented on the Earth for the last 18,000 years is only one – ***"The Civilization of Parasitism and Violence"***, and it is divided only into stages. The type of "civilization" developing in each stage was determined by the Program directions for the corresponding period of development of one or another genotype – the civilizations of the first two stages were annihilated due to the insolvency in a short time³⁸.

³⁸ Book 1, Chapter 2 «The Spiders' laboratory work.»

The Third Civilization, the third stage of the intervention, was the most satiated with experiments in all directions of its own civilization development and ended as the stage of Russia's development on this discrete path, the "**Communist-type civilization**", focused mainly on satisfying the exquisite (imposed by the old program) needs of only elite party leaders. It is completely and irreversibly eliminated. Its automotive, i.e., uncontrolled state has been fading since April **1993** at an increasing rate. Nearly 100 years ago, Communism, as a programmed type of a civilized development imposed from the outside, gained its real executive implementation by involving people with the proclaimed systemic "program idea" (no relation to paper programs of the CPSU), which was manifested through Lenin (as the executor of the conceptual level of mental labor), which he announced in the report of the All-Russian Central Executive Committee and the Council of People's Commissars on Foreign and Domestic Politics on **December 22 1920: "Communism is the Soviet power plus the electrification of the whole country"**.

In fact, not the "Soviets" were that sacred and conceptual base for the real implementation of this type of civilization development, but the hidden power of the energy being gained **BY INTRODUCTION OF THE GRANTED TECHNOLOGY** for



"generating electricity" and people involved in its execution, as "**Human executing Potential**" (which in their own way, i.e., in Marxist terms, they called "Human capital")! That is the real truth that realized this type of civilization. The comprehension of this most

important situation should not be from the position of the past orthodox materialistic world view, but from the position of an already accomplished transition to a different stage of the truth cognition – materialistic idealism. Everything has its own cause-effect relationship! Mankind is the next step of our civilization development.

Civilization of the liberal-democratic type – in practice, did not take place, but its consequences – the neo-liberal reform, led Russia to a real historical national catastrophe in our today's understanding of the ongoing events. However, one can not fail to see that against this background a number of independent objective prerequisites are beginning to be created on the inalienable and unconditional change in the basic states of the

civilized picture, which are less and less exposed to the influence of Anglo-American-European parasitism. On the other hand, we see, the main function of the aggressively parasitizing factor that restrains all processes of active and unavoidable changes in the formation of a new Construction of the organized existence of the re-created Russia there begin to play internal "post-democratic" forces. By their hands and actions, **THE ENTIRE TWENTY-YEAR OLD LIBERAL-DEMOCRATIC DESTRUCTIVE PROCESS** that resulted in the final collapse of the communist-type civilization, complete impoverishment and collapse of all spheres of people's lives, and, as a consequence – destruction of the social and human orientation of the society for the overwhelming majority of the peoples of the country, There is no need to look for a more destructive enemy, since all the others are less significant, from the point of view of their destructive influence and counteraction in the promotion of anything new for reorientation to a socially fair future. ***That is, the ratio was switched in the destructive-influencing balance: FROM EXTERNAL TO INTERNAL.*** This is an extremely important factor that fundamentally influences the general vision of the picture of the current civilized state of the country as a whole and the answer to those numerous questions of people – "why is everything happening that way today and where are we going down..?"

Why did neither psychology nor psychologists "hit" upon it, and why aren't they able to substantiate it?



Back in 1923, People's Commissar **V. A. Semashko**, addressing psychologists, said: "The broad masses of working people will find a scientific answer in the proceedings of the congress on the present day questions of concern." And everyone "rushed" to look for answers where indicated the People's Commissar. Naturally, this approach led to the fact that the science of man's mental development lacks whole systems that make up his essence. Psychologists, of course, knew about this "lack." This is indirectly confirmed by the non-published notes of S.L. Rubinshtein³⁹

³⁹ **Sergey Leonidovich Rubinstein** (1889–1960 – Soviet psychologist and philosopher, corresponding member of the Academy of Sciences of the USSR (1943, Department of History and Philosophy) [3], full member of the RSFSR Academy of Pedagogical Sciences (1945). Author of fundamental

and the materials of B. G. Ananiev⁴⁰ – on the incompleteness of psychological knowledge – published after his death. They definitely knew that psychological science described man not completely for reasons not dependent on it. I give this example to show the influence of information coming to specific individuals on the development of events occurring in the process of certain situations. However, the determining factors have always been the changes in the biological sphere of man. They were followed by the processes of change and improvement in the social environment, cognition of the world around us, technical and technological perfection, and many other actions, phenomena and events that we are now observing as final. The entire ongoing chronoprocess, related to the biological sphere of man, were oriented and presented by the most complicated processes of perfection of the **THE FULLY SPECIFIC BRAIN GENOTYPES** of people, and in such quantity that was planned by the Ebr Program *for the purpose of the complete mating with the interventionists Brain* including everything related to the so-called development of psychology as "science". Within this framework, psychology concentrated its efforts on the primary natural psychological qualities, which it "recommended" for practical implementation with the vigilant interventionists support. Today, the primary qualities are understood as traditional psychological properties of a mentally developed man: consciousness, sensation and perception, representations and memory, thought processes and speech, abilities and activities, strength and completeness of character. This list is unquestionable, like the perfection of the human body is unquestionable: the proportions, the strength of muscles, the volume of the lungs, etc. However, today one must also speak of "secondary" psychological qualities which are not discussed by psychological science. Secondary psychological qualities appeared as a result of hyper-development of the technosphere artificial environment created during the last century. As a result, both the muscular perfection in the technosphere environment does not serve as a decisive factor in recognition and the primary mental perfection is not a sufficient condition for success in it. Simultaneously with the replacement of the muscular effort by motors of all kinds there was strengthening of the Mind. This not only reduced the requirements for the applicants Mnd for success,

textbooks for universities "Fundamentals of Psychology" (1935) and "Fundamentals of General Psychology" (1940, 1946

⁴⁰ **Boris Gerasimovich Ananiev** (August 1, 1907, Vladikavkaz, Russian Empire – May 18, 1972, Leningrad, USSR) – Soviet psychologist, founder of the concept of the current psychology department at St. Petersburg State University.

it became necessary that they should have secondary psychological qualities that allow them to orient themselves in the chaos of social and technical conventions. By secondary psychological qualities we mean the reaction of the human psyche to an artificial reality consisting of equivalents of natural reality, which is described by objective logical, mathematical, biochemical and other laws of the natural environment. ***The psychology of the Mind is intended for these actions.*** However, today people have to live in the world of equivalents of the natural environment: social conventions, legal norms, economic relations, "subordinatively" regulating man's behavior. And success in it, in my opinion, is reached by one who uses ***subjective laws, and not objective ones.*** Fiction, for example, as the most sensitive method of human research, noticed the problem of substituting primary values for secondary values (E. Zola, T. Dreiser, F. M. Dostoevsky, N. V. Gogol, etc.).

Values have always run through all aspects of life of man and society. However, all preferences, orientation, individual or associated interests, were always indirectly controlled by the old System from the outside. Not only having special purpose orientation to values, but the whole structure of the system, symbolizing and personifying power, the very structural formation of societies in a pyramidal form of construction – all this was oriented ***in the name of gaining material values of different character***, directing the entire way of life of societies **TO THE STATE OF IRREPRESSIBLE PROFIT FOR THE SAKE OF PROFIT**. Literature showed that one thing to discover the might of the cognitive⁴¹ and volition processes in the struggle with natural elements in peasant labor or in the works of a physicist in plasma confinement in the electromagnetic field, and it is quite another thing to show the same qualities in operating money, vouchers, bills, exchange rates, advertising and election campaigns, information flows. These are psychologically so different things that "objectivists" are completely helpless in the system of equivalents, and "subjectivists" are useless in the real physical world. Nevertheless, the fact is that today in our realities two different spheres of life have formed, each of which requires its subtype of cognitive processes and its subtype of psychological perfection within the framework of the created Brain genotypes. Wasn't this foreseen by N. Levashov when he said that vague or rough schematic presentations of man's future, his talent and character are

⁴¹ **Cognitive processes**, human cognitive processes, including his sensations, perception, attention, imagination, memory, thinking, speech ...

the weakest points of all prognostic constructions? It turned out that it is easier to design systems with billions of social communities, artificial satellites of Jupiter and et cetera than to imagine the face of the human individual of today. And all this is because the most **DIFFICULT AND UNSOLVABLE** for the Interventionist System was creation of the Construction of such a perfect Brain, which Man possesses. The imposing of alien (non-human) Brain functions, as I have repeatedly mentioned, was carried out through the implementation of the Program **"Energy-Information Dialectics of the Brain Genotype Development"**, and all corrections of the flesh cell, giving complete controllability and harmony of the altered Brain and perfection of human flesh were performed through the Program **"Development of the Energobiogenesis of the flesh (shirt) cell"**. The Interventionist Ebr System **DID NOT MANAGE TO FORM INDEPENDENTLY** the true construction of the human brain, but only had to borrow its constructive basis from the previous true Man in the process of capturing the Earth. In the future, any attempts for the part of the Interventionist System **to reconstruct the Brain of people** did not have a successful conclusion. It is for this reason that the system program "Development of the Brain Genotypes" was started up on **May 9 of the so-called zero year of our era**, that is, forcibly imposed functional intervention for obtaining specific having special purpose material-thing-like use of people. The Interventionist system had to preserve the inherent mandatory presence of all three of its simultaneous fundamental states (neutrino, antineutrino and proton) in the construction of people's Brain. And it was for this reason that it was just impossible to simplify the potential capabilities of people's Brain's functions, since they would no longer be **independently intelligent beings** (people). Equally, it was also impossible to keep the Brain in its former true format of capabilities and at the same level of octaves, since imparting people **THE PROGRAMMED GUILTY STATE** would be insolvent in general. Having brought the general controllable state of people's Brains of that time to the level of the minimum possible energies octaves of its material and immaterial states and also having imposed the cubic basic gratings of energy-information translation and the Brain control, the Ebr system imparted the whole process of people's being a certain guided state. And "the process had gone ..." This accounts for the scientists' lack of knowledge about the Brain (according to the level of cognition of anatomy-pathologists and Darwin's teachings), its construction and essence as such. All known researches and theories in this direction are only a small part of the superficial knowledge of the capabilities of the

Human Brain – I draw your attention to Human who is yet to become Human, not people. But Man still managed to survive. It means that He managed to organize something in the course of his survival; that is, in His organization there is something that can and must be taken into account and applied while performing future phenomena, actions and events within the framework of the new Program. Moreover, something and someone helped people under such anti-human conditions to save a grain of their true human. As for "something and someone"- we will discuss. Of course, it was for this reason that the "**SvetL**" **Programms** could be created, and as I said repeatedly, **Nicolai Levashov** created **the Generator**, which is the basis in real interaction with the Brain of Man as his assistant in development and knowledge today. It is this that should not be forgotten, when there is a wish to answer the questions that practically all people are worried about today. In what way to answer is the main question. I am trying to give you "hints" in my books and articles.

3.8. The reality's simplicity

The concept of "strategic psychology" is still accepted with suspicion even by the most radical domestic psychologists, not to mention the so-called "politicians". This is natural, because the tradition of operational study of one individual "here and now" in isolation from the influence of external strategic circumstances on this person is rather strong in Russia. This happened because external circumstances are geopolitical ones, and their study was not encouraged in the country either before 1917 or after 1917. Discussion of geopolitical circumstances was an absolute monopoly of the authorities. Psychologists were allowed to study "how the human psyche functions," but the penetration into the question: "why the psyche functions that way" was strictly forbidden. The thesis that being is before consciousness was the political slogan of Marxist social science, but... practice showed the opposite. As a result, domestic psychologists very successfully formed, taught, and brought up Man for specific prescribed conditions of being. Not on their own fault they could not or did not manage to prepare their "subject of study and education", corresponding to future changes, which was forbidden to think and speak about. There is **a strong tendency of the authorities in our country to believe that if they (the authorities) draw the future, it will certainly come true**. The psyche functions as the reality allows it to function, and like the reality is like

psyche. Despite prohibitions and restrictions on psychological research, nevertheless in Russia there developed a powerful operative psychology: psychological instruments of upbringing, education, treatment by methods of pedagogical, medical, clinical psychology, psychotherapy, etc. It studies the inner circle of human problems. For clarity, you can compare operative psychology with surgery that saves man with some surgical actions. The competence of surgery, as well as operative psychology, does not include studying "why it happened to the patient" and "what will happen to the patient after recovery". The greatness of both surgery and operative psychology is in the fundamental knowledge of the man's past, materialized in the physiology of his higher nervous activity, psychophysiology, and psychology and in the ability to **"restore everything as it was before."**

Tactical psychology, as a forerunner of future changes, begins to develop successfully from the early 60's. as social, legal, engineering psychology, where man is considered in relations with another man, a group of people, technical systems or the environment. And it begins its development in Russia. Tactical psychology studies the near outer circle of human problems, which exists in the real time and space and is accessible to objective measurement. Here success is brought by highly professional scientific knowledge of the present, to which it is necessary to adapt man and a group of people. But this is only in theory. Practice shows the opposite and complete misunderstanding of what the happening is. People who believe that they have knowledge in psychology do not understand that with the knowledge gained in the past, the cognition of the ongoing processes – and even more, any projection of the future – is just impossible. And the wish to make people's behavior adequate to the time and real relations of today is failing everywhere.

Strategic psychology is only just recognizing itself as a fundamentally new branch of psychological knowledge, which came into being at the end of the 20th century. (you understand why) and conceptualized within the framework of political, economic psychology, futurology, strategic foreseeing. Strategic psychology studies the future of man, more precisely – the far outer circle of his problems – such psychological problems, which are often not yet exist but which are approaching faster and faster. The changes in the techno sphere, demographics, the structure of society, the picture of the world are so rapid that the recent fiction becomes a reality without realizing these changes by man. And the further, the more rapidly. Only for the past nearly two hundred years (the fourth stage of the digital information civilization of 150 years and

the fifth of 50), in line with the Ebr system there were changing not only social forms (from capitalism, socialism, communism (fragmentary), liberal democracy, global (local) industrial feudalism), but also the basic foundations of social structures of states, their legal and value bases in the sphere of finance, military-political and many others. Unfortunately, today people who consider themselves "specialists" in psychology issues and on this basis are trying to give some recommendations based on their knowledge gained in the past do not understand the key moment from the past, and even more so from the present – **THERE IS NOT ANY CONTRIBUTION OF PEOPLE TO THIS**. I am saying it with full responsibility – the Ebr Control System *used people only as biological experimental material for program tests in the process of the Brain genotype development*. According to the programs of the step-by-step development of the Brain *genotypes 42 and 44* for the part of the System, the most complicated actions were carried out to impose and practically develop the corrections for the most part of the entire construction of the control of the programmed processes in general and the actions of people in particular. It was planned, as I have already noted, to establish, approve and find *the most expedient ways of energy-information impact on the Brain of people*, to work out the most effective constructions for the control information, to impart the protected stability to it, all approved and the best should be prepared for the subsequent stage of development when introducing the next Brain *genotype 46*. Only individuals with the Brain *genotype 46*, according to the System plans, were to be able to integrate into the future states which the System was preparing for the future period after 2012. And all psychology, as science, through the scientists in this field was aimed only at resolving these questions. I am not in any way criticizing people who have been practicing all their lives in all its numerous directions and have achieved recognition in scientific and not only circles, I just state what is taking place. ***And it is not so important what it was, but it is important what will be.*** The comprehension of these changes, and more importantly, their anticipation⁴² – today is the same guarantee of survival for man, peoples, as recently was the preservation of age-old traditions. However, as **N. Morozov** once said, "the force of historical life is spontaneous force and if we do not know its laws, as we do not know many laws governing the

⁴² **Anticipation** in philosophy and psychology – anticipation, prediction, the idea of a subject or event that occurs before the act of their perception, the expectation of an event

elements, nevertheless, we have that negative conclusion, that the nature of this life does not depend on the individual qualities of the few, in this or that respect outstanding personalities, but is conditioned by the aspirations and interests of the majority." Until we change the way of reality perception, any life changes will be random and fleeting. In order to get a stable result, we have to thoroughly review the reasons of the occurring events. And for this we have to be opened for a new understanding of the truth and reality. Strategic psychology does not oppose to operative or tactical psychology – it only prepares information for them on changes that will allow them to adapt the past of man to his present, but which still seems to them to be the future. And it will be done through people, specific people, perhaps in the processes of psychology development as a new science about Man. To anticipate or, if you like, to predict this future, using your knowledge gained by searching for answers to what is happening in today's realities, is necessary at the maximum depth. And only those have the strength to do it who, despite everything, have taken the path of knowledge.

3.9. Forced and mandatory

Once Professor **V.A. Ganzen**⁴³ found that all the textbooks on psychology contain inconsistent sets of psychological variables that characterize man. Psychology is the science of random (stochastic) processes that may or may not occur with some probability, so modern psychology itself describes a stochastic list of behavioral phenomena that characterizes a human psyche. But why does not it touch the phenomenon of parasitism and violence? A long series of factors shows that the influence of the entire complex of ideas that are at the disposal of today's psychology as science turns out to be completely inadequate to enlighten and purify the moral world of man. Today, there are many, for whom it is quite easy to reproduce a number of names of people who, with surprising intelligence, unusually extensive knowledge, have often combined a small minded, vulgar



⁴³ **Vladimir Alexandrovich Ganzen** (February 2, 1927–1997) – Soviet and Russian psychologist, Doctor of Psychology, Professor of Leningrad / St. Petersburg State University, the author of the systems description of integral objects

and even petty person. I will not give here specific names – every reader, I hope, will decide himself. Scientists are also not always intellectually matured people, and mentally developed people are not always honest ones, in a word, a cultivated man is not the same as a civilized man. Why so? In this regard, you can find a lot of various inventions, including those with the support on modern psychology, but at the heart of these inventions there is no understanding of the main thing. And the main thing is that parasitism was a **MANDATORY AND NECESSARY CONDITION** for the existence of both the Interventionist Ebr System as a whole and all its created constructive cluster formations and control states of their functioning, including the Earth Mind formed and brought by it to the planet. Similarity creates similarity. That is why, as a core determinant of the direction and level of consciousness for individual,- I want to emphasize this – exactly for individual genotypes through their Brain functions for the part of the "Interventionist System" ***was "forcibly introduced" the first principle – parasitism.*** These people were not that powerful to resist to violently imposed upon them special states of their consciousness, which predetermined their worldview and their corresponding behavior in life, but only in the limited framework of the inalienability and mandatory of violence and parasitism manifestation **IN ANY SCALE OF THEIR ACTIONS!** This distorted consciousness, far from the true human values, for today's understanding, ***is conventionally defined as a "marvel of parasitism."*** It is not difficult to imagine what man is characterized by and, accordingly, the actions of people who experienced the impact of that imposed marvel. ***The marvel of parasitism was changed under the control from the first introduced genotype to the last one.*** But, despite step-by-step changing **DERIVATIVE FROM IT MANIFESTATION OF THE CONTROLLED VIOLENCE**, the very essence of exploitation was fundamentally unchanged at all stages. ***Only the forms and ways of violence manifestation were changed.*** Earlier this was solved through the forms of only physical colonial violence, later – it was implemented and solved by ***military-force*** and threats to take away the national values (and this is evident from so-called historical examples and facts). Now, the same thing is happening before our eyes, but already as a residual auto-motor-way like marvel. At present, the marvel of violence has increasingly attracted attention of both society and professionals from various fields of knowledge (lawyers, psychologists, educators). Articles, books and dissertations are written about violence. However, paradoxically, the question "what is violence?" remains without

discussion. The term "violence" is used so extensively that sometimes it becomes unclear what is being discussed. That's why I touched upon the question so important for the orientation in the ongoing process.

In the construction of the control process, violence was of a complex two-level nature in its final practical manifestation and implementation. **At the higher level**, i.e. in the part of the construction related only to the System, manifestation of violence was of leading, i.e. of a generating primary character. It was realized in the form of setting specific brain functions for a group of specific individuals, changing their abilities to process and expand the possibility to get more sophisticated information flows, providing specific programmed control information for its narrow identification by specific individuals with a further conscious manifestation of their organizing or direct acts of violence. For the rest of people a certain state was formed, which ensured and supported the perception of violence as a necessary and inevitable condition in the ongoing processes. This was a doomed imposition of the main form of the manifested violence on the side of the System over people in general – **to have the right to "grant life"**. This means that **ONLY ON THE SIDE OF THE SYSTEM** could circumstances develop as a level of solutions: whether the Brain is to be born with such a general special purpose of the functional endowment or not; whether to gain certain Brain functions and develop them further or not; whether to possess the imposed state for the violence realization or be exposed to it; whether to distribute benefits and services or possess only a part of what is provided, etc. **At the lower level**, i.e. in all complex executing implementations through and at the level of people, violence itself or damage from its impact had a derivative executing character. **People were involved in a common executing process without their will – this is the reason for their having been uncomplaining for millennia.** This is one of the answers to today's questions about the happening.

On the basis of **the methodology of energy-information dialectics of the Brain genotypes development** we will trace back – in what way and peculiarities **the marvel of parasitism** and the related **forms of violence** manifested themselves at every stage of civilization development, and whether it is natural? In the pre-digital information civilization of people's development in the social construction of the communal-democratic "cupola" there was no marvel of parasitism, as an influential condition for the Brain functions. The elements of physical violence among people manifested themselves in a limited way and only as a

disciplining or protective factor. During the first stage of the era of the digital information civilization – the development of the slave system within the framework of programmed control and the introduction of genotype **421** the only possible social construction was obedience of the deprived of any rights majority to the ruling brutal minority. During each stage of the Civilization development common people (the overwhelming majority) did not have such functions as individuals with **421 to 461** genotypes, and they were controlled by them. This does not mean that the majority of people were in a state of stagnation – they also went through the process of improving and changing the Brain cognitive and executing functions, since throughout all eight centuries there was an active process of preparation for the transition to a new construction basis of the governing energy-information impact both on the side of the System and of specific individuals with a given Brain genotype. The introduction of the Brain genotype **422** (the first stage of the digital information civilization era) allowed the System to activate the manifestation of the marvel of parasitism at a higher level of its impact with the tough expression of the governing unlimited violence. This was the beginning of the "**unlimited egoism**". This genotype possessed a special functional and legal status of the supreme commandment, like "People-Gods", with the corresponding peculiarities of the social constructions that they created to ensure plebeian existence for everyone else on conditions of slavery lack of rights even the right to life. With the introduction of the Brain genotype **423**, there was formed an unshakable state of the unilateral right to own all the goods and services produced, appropriated by force through the established religious-dictatorial regime, ensured by the state security forces. Nevertheless, the manifestation of these forms of violence **did not give that effect**. The state of apophaticity⁴⁴ from the religious sphere was transferred to the sphere of secret orders and clans with the introduction of genotype **441** in the third stage of the digital information civilization era. Along with this, all functions of the lawless excesses were transferred, to up to the unlimited physical elimination of people. The effect of the "cave-animal" state of cruelty has increased substantially, and not only in the form of physical violence. The legal field finally approved it in the form of the law guaranteeing the mandatory imposing of power in all spheres of people's being. The inhuman functions of **genotype 442**, as the stage of hegemony of the bloody genotype (the fourth stage of the digital information civilization

⁴⁴ **Apophaticity** – ("negative"), or **negative theology** – the theological method, which consists in expressing the essence of the Divine by consistently denying all its possible definitions as incommensurable to him, cognizing God through understanding what **he is not**).

era of human development) by their target orientation, imparted them an incredibly cruel and bloody character in all the executing processes. A special form of violence of this period was organized and manifested through the created constructions of political systems, both on the basis of capitalist ideology, and on the basis of communist one, of equally important, governing state violence. **Political violence** was completely oriented and framed in the **"Might of Power"** program by a leading group of genotypes through the fragments: Revolutionism, Militant Communism, Fascism and Destructive Democratism with the corresponding social constructions governing the people' being on the basis of the marvel of parasitism and the complex governing violence derived from it.

Economic violence was in an open and larger scale than physical violence – this is the result of the programmed implementation of genotype 441, which ultimately led to the single strategic implemented goal of the System, that is, the preparation and implementation of **the "Golden Million"** at a subsequent stage of development. Significantly there changed functional endowment for the leading groups of new Brain genotypes **461** and **462** (2009, I emphasize – in solitary numbers) through CC California, which led to the change in the level of this marvel of their parasitism influence and its subsequent manifestation through the governing violence, which influenced, first of all, radical change in social structure and the sphere of power in general. All the consequences of the manifested violence against Russia were expressed through the imposed implementation of liberal reforms, which, in fact, brought the country to the historical catastrophe, with their results, I draw your attention, readers, – we should not assume that the Ebr system marvel of parasitism and violence is a natural "phenomenon", and all outgoing executing actions of people of such a state of consciousness diverted from the truth is also natural and, moreover, a historical regularity. Of course, **CATEGORICALLY, NOT**. It is in this that social science, as well as psychology, are deeply mistaken and partly by this mistake are guilty of a practically accomplished catastrophic tragedy both in the results of the civilization development of people (especially the last century) and in the appearance of the very fact of the anti-civilization plot of the international oligarchy – **"Globalization"**. Yes, it is interference through violence on the side of the Interventionist System into the processes of people's Mind development; yes, this, in the end, is the Systemic violence over the entire course of the Civilization development of the Earth's reasonable orientation; yes, this is just violence on the Earth, but **IT IS NOT NATURAL PHENOMENON FOR THE EARTH** and, even more so,

supposedly historical regularity done by the executing actions of people. Against this backdrop, everything that is related to human psychology is not exhausted by the range of issues that we are considering in this chapter and which have been touched upon in the previous books. It is necessary to consider what kind of help psychological science can provide not only intellectuals, but also people as such, to regain their place in life and the society that is undergoing global transformations. To do this, we have to try to expand the current differentiation of psychological knowledge.

3.10. Reasonableness in unreasonableness

All knowledge originates in Reason. Unfortunately, at present, when referring to the concepts "Reason", "reasonable" in the context of human behavior in human society, there is complete arbitrariness. Very often, a "reasonable" decision is understood as profitable one; "reasonableness" is taken for – man's knowledge and his operation of certain dogmas, which are considered "reasonable" by the one who gives the definition. However, Reason and Reasonableness are something completely different. Reason has nothing to do with the benefits and knowledge of dogmas. Man striving for profit believes that there are certain beneficial conditions that are important for him and he will seek the opportunity to get these more beneficial conditions for himself, discarding any other issues that are not directly related to the problem being solved. Reason is the ability to come to the right conclusions in general and **SEE THE DIFFERENCE BETWEEN THE TRUTH AND THE ERROR** without any thoughts of having profit. In our today's abnormal and unreasonable society, a stereotype is prevalent, according to which ***Reason is only an instrument for satisfying certain needs and should serve the purposes of profit.*** In fact, everything is not so – not the Reason is intended to serve the purposes of profit. Only Reason can determine what is profitable and what is not. Unfortunately, the overwhelming majority of people do not understand at all that it is necessary to study any things, since, by misunderstanding something in the world around us, we endanger our existence and deprive ourselves of potential opportunities that we do not know because of being ignorant.

Reason is a universal ability to see the point of what is happening in the world, and not to get stuck on some dogmas and bear in mind certain conclusions – just as literacy is the ability to read in general,

and not to read a certain word on a particular signboard. If man finds himself in some difficult situation, he should find the way to act in it correctly – that is the point of Reason, – to find the right decisions and be able to understand the situation in general, but not to know certain stereotypes and confidently operate with them. In other words, the reasonableness for our modern society means not the ability to draw a conclusion at the level of "if the tap is open, water flows from it," but make conclusions about the more complex patterns and subjects related to the entire complex of our society's problems, concerning all moments of its functioning. We have to comprehend the relativity of reasonableness, that this is not an absolute property, and the reasonableness for us now, in our time and in our realities, is the ability to find the right decisions, to orientate, to act expediently in the realities of our life. Against this background, today's philosophy are the unintelligible answers to insolvable questions. And psychology is the right choice of words for an incorrectly formed conviction. Well, the psychology of **Reason** is the content of classical psychology (science and practice), which has built up the modern society. This is not only science, it is nearly religion of our civilization. Psychology could not be developed with the depth and completeness that is possible provided the friendly cooperation of all the forces of the collective mind of people. Hence the insignificance of its results, its relative fruitlessness. It could gain that spiritual ennobling influence on people, which should rightfully belong to it as one of the properties inherent in its nature. Hence its moral powerlessness. Serving the interests of a few, obeying the demand of only the minority that created it, this psychology of "Reason", and whose interests were completely exclusive and in no way in sympathy with the interests of the majority, it was necessarily limited to only those few tasks that were included in the circle of life of this minority. Hence its extreme one-sidedness. Why is that? Well, because people refer the concept of "Reason" only to the sphere of the Conceptual Power as one of its governing fragments for supporting people's lives. Reason, as a substance of the society, is an objective reality only under the condition of the functioning of the Conceptual power itself for specific program circumstances to ensure and support the life of people in the present complex habitat conditions. **Reason, and even more, so its psychology, can not be subjected to any instrumental research.** It can not be investigated, can not be subordinated to anyone's interests without the "sanction" of the very Control System. No country in the world, possessing any most perfect statehood, does not possess this power at the moment and, accordingly, can not initiate the formation of new Reason of people. Human societies do not have the

technical or other capabilities to have feedback from the true Control System, so all attempts to form their "Planet Reason" are vain and were doomed to failure. The Ebr system, having imparted the whole process of people's being a certain controlled state in a relatively short historical period, formed the primary substance of its **ARTIFICIALLY IMPOSED INTERVENTIONIST REASON** on the Earth and simultaneously imparted the corresponding governing state to people's Reason, thereby ensuring the complete "technical" isolation of the latter from the previously existing contact with the true states of the "Supreme or Universal Reason". Thus, the true, that is, naturally given by nature with the imparted cosmic functions of its mission, the outside control **WAS REPLACED WITH THE IMPOSED ILLUSION** of the imported control from the side of the Ebr System as supposedly control from the "Artificially imposed Almighty", but not the True Creator. The interventionists could not have any other option, since their strategy had envisaged the ultimate capture of the Earth. This was followed by the processes of "improving" such forms and methods of the control and with such a corresponding correction dictated by the System of States of Consciousness and its psychology which provided not "unconscious material object-applied state of people" at all stages of the so-called Civilization development, but having no relation to the true Earth Civilization with its programmed native orientation. All this accounts for the incorrectness and viciousness of **THE LEVEL OF DEVELOPMENT OF THE DESTRUCTING CIVILIZATION**, which has been found to this day, and the corresponding vicious Structure of the organized existence of people as atavism of the past. It's time to appreciate Man's virtues by the criteria of developing his thinking, memory, attention, speech, perception, measuring the quality of his knowledge, skills, getting control of one's behavior and the outside world.

But how did all this form in the historical plan with the involvement of people (their Brains that have reached a certain development)? This will prove useful to understand the control processes and the Ebr Control System achievement of specific goals in order to look deep into the ongoing nowadays. The beginning of the psychology of Reason, in the modern sense, conventionally speaking, belongs **to Roger Bacon about 1272**. He reoriented the psychology of thinking to the generalization of realities, not words, formulated the basis of psychology of Reason. Less deliberately it began with the opening of the Academy in Languedoc in 792 by Henry de Zhelon. The main problem of psychology of Reason is formulated in 1122 by Abelard in his work **"Yes and No"**. The fruits of psychology of Reason are



a compass (1150), a clock (1220), geographical maps and the goniometer (1250). Then Occam laid the foundations of the empirically oriented psychology of teaching and thinking (1345). Psychology of Reason was strengthened by such arguments as Copernicus's work *On the Revolution of the Celestial Spheres* (1543), which sounded like "a signal of the day of judgment for the false philosophy." After that, **in 1590, Goklenius introduces the concept of "psychology"** into science. The fruits of psychology of Reason: the law of universal gravitation, the theory of light, the chemistry of

gases, the transformation of energy, the steam engine, and electromagnetism – created the conditions for a fundamentally new system of education.

Modern pedagogy grew out of psychology of Reason, when in 1631 J. A. Komensky in his work **"Great didactics"** demanded "studying and exploring the real world, and studying and exploring the very things, but not only others' observations and descriptions of things" . Almost simultaneously, in 1640, there appears Descartes' work **"Rules for the guidance of mind"**, where the only unquestionable object of introspection is thought. By 1690 Newton's dynamic principle is widely spread, proving that physical properties that are accessible to experiential knowledge and mathematical generalization can be recognized as real objects. After psychology of Reason, there naturally follows, D. Locke's psycho-pedagogical work **"Experiments on the Human Reason"** (1689) and the answer to it by V. G. Leibniz **"New Experiments on the Human Reason"** (manuscript dated 1705, published in 1765). Differential calculus (1684), integral calculus (1693), calculus of the infinitely small (1702) by Leibniz-Newton are a symbol of the psychology of Reason power.

Pedagogy continued to accurately and consistently implement psychology of Reason, improving its methods approximately every 30 years. Teachers of the "Helvetia wave" (1715) make a departure from the psychology of faith and drift to the psychology of Reason. Then the pedagogical **"wave of Pestalozzi"** (1746) promotes the idea of developing thinking in spite of mechanical accumulation. **The Herbart Wave** (1776) develops new instruments for psychological science, which criteria are clarity, system and method. **The "Ushinsky's Wave"** (work of 1813) achieves the fact that science distances itself from all religions, since it relies on facts, not on

beliefs. ***"The Wave of Kettel"*** (work of 1860) systematizes, classifies the work of Peason: people begin to be appreciated in terms of ability to remember for a long time, keep steady attention, make logically correct conclusions. ***The times of the "Makarenko wave"*** (1888) fall on a difficult period of general "technologicalization" of all sciences, when K.N. Kornilov (1879), P. Blonsky (1884), S.L. Rubinshtein (1889), L.S. Vygotsky (1896), BM Teplov (1896) work. Their peers abroad are W. Keller (1887), M. Wertheimer (1880), K. Koffka (1886), K. Levin (1890), E. Thorndike (1874), D. Watson (1878), W. Köhler (1887), Kretschmer (1888). They brought the dimension of the human mind to perfection, and the technology of its development – to the craft. ***With their works, we live in the aura of Reason worshiping so naturally, as if nothing else exists.*** However, people brought up on the model of "psychology of Reason", are increasingly becoming intellectual slaves of primitives. What did not they know? They could not believe that the products of Reason would be replaced with imaginary equivalents.

The development of Human Reason on the Earth for the 18,000 years was oriented in the narrow framework of the material programmed interventionist application as a private tool for imparting people guilty executing state, i.e. for their common systemic other purposes. Everything that is meant and called Reason, including the entire knowledge of the surrounding world reality and the people's feedback with it, are created and provided by the old Control System through its Complexes and Control Objects. In the hierarchy of the energies being significance as such, Reason is that Supreme Beginning, which is substantially higher in its position than the life of every being on the planet Earth. Moreover, it is Reason that determines the program objective essence of being. It is worthy to call it none other than the Supreme Reason substance state. That is why there are numerous questions and problems which the present science can not give substantiated answers. – All this, including cognition, was the process of violence of the object-programmed substance of the Reason state over people in all their thoughts and their being realization essence. And this ***VIOLENCE WAS TOUGH AND DIRECTED FROM OUTSIDE by the step-by-step program for the Brain genotypes development.***

How, then, was this realized not from the point of view of the so-called "story of the process", which I have told, but from the point of view of energy-information dialectics, from the position of the Ebr reason state substance formation in the stages of the Brain genotypes development?

Before the first genotype creation, the entire being of people with the participation of objects 440 was oriented to the preparation and improvement of the organism to the condition suitable for the installation of the functional future Brain genotype. In 1605 BC, genotype of the Brain **421** was formed. This was the first successful attempt of the Interventionist system to inset its (spider) brains in the "shirt" of people. On the side of the Interventionist System, by introduction of the first group of mantissas for genotype of the Brain **421**, work began on the formation of the primary substance of the Ebr state of Reason. ***This was a historical period of the final phase of the "pre-digital information civilization of human development"***, that is, the entire control process was carried out with the help of energy information, which **WAS NOT BUILT ON A DIGITAL BASIS**. The provided contact of individuals **421** Brain genotype with the emerging substance of the Ebr state Reason laid the historical beginning for a deviation from the general harmony with the Supreme Reason state. With the formation of genotype **422** (from 822 to 0 g.), the information of the governing substance of the Ebr state Reason begins to be transferred to its own digital basis. It was during this period that the state of people's disharmony with the Supreme Reason was basically fulfilled. In connection with the introduction of 12 mantissas for new **423** Brain genotype (0-1433), many of its functions gained a completely different, higher level of definition of contact with the Ebr Reason substance. New Brain genotype **441** (1433-1841) embodied all the advantages of energy biogenesis of the "shirt" of all previous generations and the level of the Brain's functional and contact-information ability to receive information from the System. The main characteristic of this period is the fact that the program-determining control substance of the Reason state has finally passed into the position of "**Digital revenge**", i.e. all the control information is transferred to its own digital basis finally. The following individuals of the Brain genotype 442 had a higher ability to accept and perceive only the "program-object" reality provided to them by the Reason state governing substance. Complexes of the Control (the Caucasus and the Alps) formed the programmed individual and associated "program-object" Reason that oriented all the individuals of the planet ***not to the true objective reality, but to artificially created by the System***. With the introduction of new mantissas, the System through its Control Complexes, including the Alps 2, created all the circumstances of a significant change in the essence of the program-determining control substance of the Ebr Reason state, imparting it an **AGGRESSIVE**

DESTRUCTIVE NATURE IN EVERYTHING. The degree of deviation from the harmony with the primary substance of the Supreme Reason true state has reached its maximum limit. Its programmed directions ***changed the special purpose functions of the general Target Vectors of all future phenomena, actions and events,*** including, the Brain Development Program, as part of the overall program, almost up to 1985. At the 5th stage of the era of the digital information civilization of human development (1990-2000), the Brain genotype **461** was introduced by putting into an active state the California Control Complex (1990). The California Control Complex according to the program, in addition to formation of the associated reason of a different level for this genotype, was to conduct a personified formation of the object Reason to certain individuals or to their limited groups, adjusting its level and state to their program functions. Such a process was supposed to significantly change a lot in their authoritative social status and position, provide a special legal basis for their existence and executing programmed activities on the conditions of an unquestionable legitimate state as "the power from the Almighty," to support and ensure the cleansing of the entire power pyramid for the programmed actions of "the Golden Million. " But in the period until 2009, for a number of reasons known to us, there were serious system failures. The program-determining substance of the Reason governing state in its information basis not only completely, but **FINALLY TRANSFERRED TO ITS OWN INTRODUCED DIGITAL START.** ***Some of the people no longer had a framework of freedom in the perception of the surrounding "objective reality".*** This condition affects all individuals of Brain genotypes **42, 44** and some fragments of genotype **46.** **The attempts to introduce genotype 462 in 2009 did not bring to success.** There was a serious systemic shift – the program-determining governing substance of the Reason state, introduced by the interventionists from outside, began to malfunction at its large-scale pace in its induced "objective reality". ***On the scale and outside the sphere of human essence, there took place the collision between the essence of the program-object Reason of the old Control System with the emerging Reason of the new Earth Control System.*** The process of implementation of the conflict situation of the Reasons states has come, the true native Reason of the planet Earth has begun to gain its regenerated state. The violence of people by the object-program state of Reason is changing to the initiating harmony of Man with the new state of Reason. Since February 2010, an active process of returning the future Humanity to

harmony with the first program substance of the Supreme Reason state has begun. Human is returning to Humanity. Russia is the beginning of the new Reason embodiment, and it has the right and the opportunity to organize a transition to a completely different, new world view: "The power of physical violence in the authorities is being changed to the power of Reason." This is the most unusual and unexpected state and effect of Russia in the conditions of the still existing but weakening sphere of the authority of the going away World Order of the complex violence. This is that indefinite and inaccessible condition for any modern construction of statehood and world governance structures that will lose the might of its power in a short time. That's what is happening today before our eyes, but unfortunately this awareness is beyond the power of people's "distorted" Reason. This was one of the main components in the creation of "SvetL" Programs in order to at least somehow enable the Users of the Programs (their Brains) to adapt in such complex processes of today's being. The most important thing in this context is the process of ***Man's recreation***.

3.11. Unconsciously but with Faith

Until the early 90's ***Psychology of the unconscious*** was beyond the psychological and pedagogical education in the USSR, so there are many who still believe that it serves only as an indirect reminder of Z. Freud or is used for medical and entertainment purposes. Meanwhile, it invaded life of each of us much wider than modern advertising, mass media, mass culture, cinema and television, election campaigns, political propaganda and agitation – its derivatives. All commercial and political pressure on the mass behavior is entirely built on the laws and mechanisms of psychology of the unconscious. The population has no immunity against it, but so-called intellectuals ignore its commercial and political claims. A sign of this is that they despise political campaigns, do not participate in elections, do not watch shamanistic TV, etc. As a result, they gradually become its social and economic slaves. Psychology of the unconscious historically came into being as an instrument of the manifestation of various kinds of heresy – that is, when it comes to doubt everything that psychology of Reason does not always explain. If the sign of psychology of Reason is openness, then psychology of the conscious is primarily characterized by the sacrament.

Hidden, implicit methods of the control, the desire to influence gently, indirectly require the avoidance of direct force countermeasures and,

therefore, **THERE IS NEED FOR FORMATION OF NEW KNOWLEDGE**. The first heresiarch is Valentine, a native of Alexandria (150), followed by the founder of Manichaeism Mani (240), Arius of Alexandria (324), Liberius (360), Pelagius (405) and other monophysites. Later, in 1300, the works of astrologer Firlik Materna, the first physiognomy of Peter von Albano (1380) were created. Then followed the work of the alchemist Vasilis Valentine (1415), in 1518 the book "On the Magic of Crystals" by Albert Veli was published, the predictions of Paracelsus (1536) and Nostradamus (1575) were published. By today, some of these disciplines have become universally recognized sciences: psychometry gave birth to experimental psychology, herbalists – to pharmacology, etc. They have undoubted achievements in the form of universally recognized psychotherapy, psychometry, etc.



However, scientific knowledge was program dependent and not subject to the will and desire of people. This is not a tragedy and no reason to deprive the science of confidence in the level of knowledge that it has acquired. Everything it knows has been accomplished exactly as it was provided in line with the program from outside, with the subsequent application of all that is known in the processes of incarnation, necessary and **FORCEFULLY DICTATED BY THE OLD SYSTEM**. It was only possible to know what and in what way it was programmed from the outside as a separate control process on the side of the old System. For example, the manifestation of nuclear energy technology, computer communication systems and much more, as such, were impossible either earlier or later, since their realization was indicated for certain time determined by the Control System. Some of the forced fragments of the outstripped character, *which until now have been an unexplained mystery for many areas of science, took place*: pyramids, not-hand- made caves, dolmens of various forms, some technical perfect devices, calendars, facts of accurate calculations, etc., and everything – on the basis of sufficiently high technologies that do not correspond to the level of knowledge, and not only of that time, but nowadays. This is an extremely interesting point. And if psychology of Reason gave birth to atomic energy, genetic engineering, computer communication systems, the currency system and lost control over infinite capabilities of man, then psychology of the unconscious, at its designated time, took the leadership in resolving the problems of society . Legalization

of this direction of psychology occurred imputed through such personalities as, for example, the hypnotist **F. Mesmer** (1760–1815), the abbot Farish with his first demonstrations of verbal immersion in hypnosis in 1813, the Fox sisters in the United States with their sessions of spiritualism in 1848. After 1900 Freud's psychoanalysis is widely supported. Since 1928 Forel carried out a powerful campaign to protect hypnosis as an acceptable treatment procedure.



In the years 1939–1957, the psychology of subconscious perception discovered by Petzlom, Sidis, Dixon, Miller and others is widely discussed. In 1955 Napoleon Bonaparte's ban imposed in France on the books of Count de Sade is lifted in France and the sexual revolution begins in the West. Psychotherapy is becoming a routine medical procedure and since 1980 has become a powerful tool for changing consciousness, for example, in the version of the psychologist Virginia Satir. In the framework of the training of managerial personnel, in 1982, in the USSR there began a wide practice of using methods of psychological programming using the methods of Bandler, Grinder, and others. After 1985, the sessions of the massive suggestive impact in the performance of Kashpirovsky were broadcast on TV to multi-million TV viewers.

Since 1992, a powerful campaign of commercial and political advertising on the basis of psychology has been unfolding on the basis of psychology of the unconscious in all the mass media of Russia. The emergence of psychology of the unconscious accounts for the propaganda and advertising in the media, mass culture, election campaigns, the art of

cinema and TV. All these were the stages of the program in the framework of improving and developing the specific Brain genotypes which we have discussed. Against this background of the old control programs automatism, which no longer work, the country was fed up with its "public opinion" erupted from the mouth of the same "subjective heralds" that seized the entire information space of Russia. Quite an example of a certain commercial group, for money capable of any vicious actions, is the Academy of Television. The society in its inert habit, partially preserved from the civilizing communist development, **SO FAR AUTOMATICALLY STILL BELIEVES TV!** But it is only for the time being. With this kind of approach, not a picture of the present-day Russia civilization development is formed, ***but with a certain purpose the main focus of the society is diverted from "those enemies and perpetrators", there triggers off an outburst of protest movements "in the wrong place, with the wrong goals and at the wrong time"; a vague veil covers the true picture of the distribution of goods and services produced,*** or rather, robbery, instead of distribution; concealment of the main, artificially organized social and other problems by raising to the level of nationwide unrest the problems of minor nature and much more. But this is a temporary phenomenon within the framework of global changes, which we are watching and are going to experience. It can not be in another way. But what is important is that many people already have their own, though emotional, but their own assessment of the ongoing events.

Psychology of faith has long been withdrawn from psychological education and upbringing, and the masses of people have been deprived of the most powerful instrument of their life support. The boundaries of the point and essence of the state of faith are far beyond the will and wish of people today. In the past, most of the established concepts of faith were more often associated with the religious sphere, and this is explicable. Psychology of faith relies on psychological mechanisms of persuasion, which have been widely used since the theological disputes. Man having faith in "something" is psychologically extraordinary strong. This "something" can be belief in God or in one's abilities, destiny or mission. Believe in all this at once or at least something one is a mandatory and necessarily condition of Man's vitality. Psychology of faith is the backbone of the whole structure of human's psyche, and faith is a special program state gained together with the functional endowment of each man with the birth of the Brain for the system initiation of some of its functions, which ensures a correct process of comprehension of the received information, as surrounding objective reality,

with all the subsequent executing states, as a consequence. It is faith, as the programmed predestination, that does not allow most of the Brain functions to "make mistakes". Therefore, Man before faith is not free, in all the broadest spectrum of its practical manifestation. For some people it is belief in scientific dogmas, and for others – in religious and political-social, perhaps, some other, having a more simplified worldly or short-term emotion-sensual character. This gives an answer to all the questions that have remained unanswered to this day, both among representatives of science and all the ministers of the religious sphere. **Psychology of faith** was formed in the process of theological discussions, which were, in essence, disputes about what man should be guided by in his search for his place in life. According to Christianity, "now faith is the substance of things hoped for, the evidence of things not seen" (Hebrews 11: 1). Man successfully resists the hardships of life only when he identifies himself with the human race, with specific people, state, place, profession, with the members of the collective and his family. The very fact of identification is already a fact of faith, which gives him mental strength. To gain the knowledge of the truth about the essence of Life within the framework of the Reasonable Orientation Civilizations development means to gain grasp of the truth of Consciousness, Reason and Matter. That is the most important. The knowledge of this is the basis of the whole world outlook at the "World Created". This, first of all, will allow us to gain and convey sensible perception and clarity of the Faith in a special true role and place of Man and Humanity on the Earth and far beyond it. For the newly formed living space on the Earth, this will be a higher Faith on the fundamental truth about the **ACTUALLY PERCEIVED ONGOING REALITY**, rather than the mythically intimidating and **depressingly unexplained dogma of the past** about something vague, Almighty punishing, whose portraiture-sculptural being is imposed as if from outside (by the Interventionist System) The main thing in all that is stated is that **THIS NEW FAITH IS COGNIZABLE** in the process of Man's recreation and granting him the truth about the "World Created". On the side of the recreating Man, It is pure in perceiving him of its place and role in the common real universe and being of matter of energies. It is completely isolated from the vague legends about the unrealities imposed earlier by the interventionists. The New Faith is spiritually sensitive to the true Creator, in whatever format it is perceived by the integrated into the future people, unlike the previously humiliating state of the entire spiritual essence of people before something "uncertain and unperceived" by them before "whom" (since his name has not been stated

yet), on the side of **the EARTH "GOVERNORS" IMPOSTORS**, the depressive state of fear and threats of permanently imminent punishment from **some outside "Uncertainty"** was administratively injected. When reading you should not be puzzled with "elaborate" and incomprehensibility of some strange words, as it seems to many of you. You have to re-read the whole sentence and understand the depth of what is said, since the information embedded there can not be conveyed with our common words to which we are accustomed to. It's time to begin to get used to grasping these "elaborate", but truly Russian words, whose similarities can not be found in other, so-called "foreign" languages. In his time, S.N. Bulgakov stated that **what one can believe one can not know: it goes far beyond consciousness, and what one can know one must not believe**. Who believes in the multiplication table or the Pythagorean Theorem? They know it. According to V.S. Soloviev⁴⁵, who does not believe, for example, in being and the truth cognition and does not accept the reliability of the first grounds of rational thinking, he certainly will not do anything for science. In my understanding, faith, like confidence, is inherent in every man, regardless of his beliefs, and it depends not on his freedom, whether to believe or not to believe in the existence of the external world and in his own being. The essence of faith is that if our feeble thought search has not been crowned with success, we must be unshakably sure that there is an answer. Faith resolves riddles that puzzle the theoretical mind. And full conviction came, when the development of **the "SvetL" Programs** was started.

Understanding of faith as a way of avoiding contradictions is most briefly expressed in the Augustinian saying **"I believe in order to understand" (credo ut intelligam)**. One of the most outstanding creators of psychology of faith was **Athanasius of Alexandria**, whose life is connected with the **"New Testament" of the Bible (393)**. He said that the truth that seems to be the truth by people's opinion should be distinguished from the truth, the true truth which is such due to human faith. Another theorist of psychology of faith, Augustine the Blessed, stated that the beginning of evil in the soul was self-will. The will, free in its decision, is the reason that man does evil. Psychology of faith most significantly

⁴⁵ **Vladimir Sergeevich Solovyov** (16 [28] January 1853, Moscow – July 31 (August 13), 1900, the estate of Narrow, Moscow Province) – Russian religious thinker, mystic, poet, publicist, literary critic; Honorary Academician of the Imperial Academy of Sciences in the field of elegant literature (1900). He stood at the origins of the Russian "spiritual rebirth" of the early 20th century. He influenced the religious philosophy of Nikolai Berdyaev, Sergei Bulgakov, Sergei and Yevgeny Trubetskoy, Pavel Florensky, Semen Frank, and also the work of symbolist poets – Andrei Bely, Alexander Blok and others.

determines socio-political and private life of people. During the seven centuries **before 0 BC**, an executive process of special "spiritual work" and special "spiritual labour" – service to God, having its own peculiarities in achieving one's "spiritual needs" for each class, was formed and worked out. Since the 700-ies BC, through the representatives of previous Brain genotype 422, functions of the Brain in a special executing process were elaborated and brought into active state, – formation of an extremely complex program control process of "needs", – Higher Spiritual Beginning. To grasp the subtleties of such an executive governing process, it is necessary to take into account some features associated with this. First of all, one should consider the existing diversity and difference in the activity of energy-supporting servers of the Control Complexes for supporting different Brain genotypes functioning. This influenced gaining of the programmed states control experience and characteristics of effective executing practice in the processes of the programmed states control – **"needs, labor and work"**. Moreover, it is necessary to take into account the corresponding established and entrenched differences in the basic foundations of the traditionally demonstrated organizational and structural nature in the authoritative sphere, as well as specific endowments in the sphere of morality and ethics that have developed and are based on the executive states. With all this in mind, there were introduced, as theology determines, "ordained" relevant various basic and functional foundations of the spiritual programmed control definition of the whole process of **THE CONTROL IN THE SPIRITUAL SPHERE – RELIGIOUS CONFESSIONS**. These religious confessions were: **Judaism, Christianity and Islam**. This is an extraordinary important issue for the whole sphere of development control in general, for all subtle aspects of the program control processes, both the state of "needs", and "work and labor." It, as the process, was completely dependent on the state of the controlled programmed Brain genotypes development. Finally, by 0 AD with the introduction of the Brain genotype **423**, the entire process of controlling human beings was prepared to transfer the general state control of the processes to religious and confessional methodology of providing governing states in the sphere of power. This was in line with the entire redistribution of the hierarchy of the governing programs and executing processes, including "needs, labor and work," the methodology for



determining values through the spiritual beginning, etc. In all types of faiths, religion, as a special state of newly gained consciousness, has become not only the basis of all spiritual, but also subject's values, i.e. ***the main effective instrument for the implementation of the functions of violence by the executors from the Conceptual Power, and was the main link in determining the spiritual and power structure of the statehood, authoritativeness, and law.*** Today, all those who we see in power try to keep all the above and not only in Russia, but all over the world. However, very little works out. And you can see it with your own eyes..

Religion, in an orthodox tough way, but successfully functioned in the future with its sufficient effectiveness in governing people's executing actions until the end of the XVIII century with the active support of the CC "Caucasus" (Ararat, Kazbek and Elbrus). It does not matter where earlier or later such a state of consciousness gained a sufficiently effective character on the processes of people's executive actions. It is important that this fact as such **WILL REMOVE ANY NECESSITY TO CONTINUE LONG-TERM HISTORICAL DISPUTES** – on which "Mount" HE has given parting blessing and for which religious confession, first of all, while not forgetting the "heroism" of Moses and his great martyrs-companions, as emanating until now apophatic strength and the unforgettability of their "selectiveness". The only temporary deviation from such religious dogmas at a certain historical short stage, as a separate program episode of a special form and social governing construction, is the "ideology of Marxism-Leninism", ***which temporarily overshadowed by its predominant power of effectiveness.*** The names of Kant, Feuerbach, Hegel, Marx, Engels, Lenin, Mao Zedong, Hitler, Stalin became not only known, but the faith that they created carried away many millions of people, re-mapped the world, resettled peoples, redistributed power and resources. In the 70-ies. there appeared new ideologists of the wave of psychology of faith: Toffler, Naisbit, Ferrarotti, Marcuse, who laid the foundations of the new information society faith. Psychology of faith gave birth not only to classical religions, but also political, social organizations, parties, corporations, etc. But **THIS WAS A GOVERNING PROGRAM PROCESS.** It regained its previous norm immediately after the end of such a control program procedure, and the "parishioners" returned to their habitual being. One "shepherd", in the face of an ideological commander, – the CPSU, like the Mind, Honor and Conscience, was replaced by the previous pastoral government, but no longer possessing that effective state of power. Religion

is a special form and methodology of the world cognition, **conditioned by belief in the supernatural, including a set of moral norms and types of behavior, rituals, cult actions and the unification of people in certain governing organizations (church, religious community, etc.)**. But now religion is just an atavism, and the new "scientific religion" in harmony with the new state of Reason is a part of a whole set of the control tools at a higher level than in the past program processes. Russia can and must necessarily possess this tool. **Sacred historical materials should be transformed into a new, that is, different state, to impart them an explanatory strength**. And all the mysterious uncertainty and tough apophaticity in everything should be reduced to minimum in people's comprehension. Man of the near future, gaining the Reason of a different state, will perceive the present day basic foundation of religions as nothing but a fascinating historical scenario of the ethnic cultural heritage of the past.

Psychology of will. The will imperceptibly became an accessory of military and sports psychology and almost completely disappeared from the arsenal of classical science and pedagogy. Today many people continue to demonstrate the ultimate achievements of personal courage, jumping from the heights beyond the clouds, plunging into the depths of the ocean, skiing down on the sheer slopes, overcoming the World Ocean alone, flying into space and unbearably suffering there for the sake of science. But at the same time, a mainstream of people does not make the slightest effort to start the work in the morning, give up some vicious pleasures, make oneself think over the unresolved issue, imagine the prospect of one's own life. **The oblivion of psychology of will as an independent direction, comparable to psychology of Reason, is erroneous**. The importance of psychology of will for man is determined by the fact that without it coercion and self-coercion are impossible: self-control, self-regulation, self-government, self-education. All that is "self" is will. "Self" is a psychic effort that connects the motive and action of Man. This effort can be applied to one's own actions, and can be used to shape the actions of other people. Without volitional effort, no action is taken, no action is carried out, no activity is realized. Any success necessarily has as its basis an enormous resource of willful efforts to overcome external and internal obstacles. Possession of high-willed qualities – the key to success of anyone and everyone. But it still needs to be achieved. All natural human behavior is built on psychology of courage, determination, endurance. Willed people, regardless of their other merits, are highly valued today, especially in sport, military service, extreme human activities. The

weak-willed in such an environment are despised, rejected, even destroyed. But all this was "done" only within the framework of the Brain genotypes development. Psychologists recognize that psychology of will is difficult to experiment with, for examination, observation and description. Researchers and creators of psychology of will have tendency to leave behind some facts of battles, victories and very few analytical materials, because the introduction of another "assessing methodology", based only on the prevalence of social parasitism and imposed financial violence in all forms of its possible manifestation, led to the implementation of such a construction of the limited social society arrangement, in which the entrenched social parasitism has reached the level of its highest cruel efficiency, bringing **to complete suppression of people's will**. The focus of science on will are the armed forces, law enforcement agencies, special services, covered in romantic forces of direct confrontation, physical and moral suppression of the opponents. The gift of achieving results at the price of immediate and extraordinary effort is not so common. Although no success in life comes to a weak-willed man. In general, reading the works devoted to the problem of will, you see how freely some psychologists treat this concept. Will is brought up, shaped, strengthened and made weak, disorganized, freed of restrictions and imposed on others. Will can be, according to psychologists, mature, strong or weak, one's own ("to act by one's own free will") and imposed ("act not on one's own"). And when a reader come across such disagreements even with the same author on several pages, he either really begins to believe that will is **something that one can hold in hands** or at least see, or if the reader has a critical mindset, begins to doubt whether there is a correct use of the concept of "will" at all, and if it exists, is it possible to make out what exactly it means. It is possible and necessary. Only one should not forget that the Interventionist System, laid in the basic foundation of the principles and control goals for the entire development of people, the meaning of their being and stage-by-stage orientation of the civilization development with the **PROGRAMMED LIMITED AND THE ONLY MATERIAL-LIKE APPLICATION OF PEOPLE** The old System did not have any other strategic and targeted orientation regarding the development of people. The life of people in all its essence is the result of involvement them into general material-like chronoprocess of the so-called history. The defining condition for this essence of life is the System's **VIOLENT IMPACT ON PEOPLE BY THE CONTROLLED INFORMATION**. This only means that the programmed stages of the energy-information improvement of the Control System itself strictly corresponded to the people's life development stages

with all the manifested results of their behavioral implementation in the organized being for them. All social relations were built only between **the governing and the governed classes**, as the only one executing process of the program implementation at each individual stage of the Civilization development, controlled by the old System. Therefore, all questions related to psychology should be considered only in this perspective. And then the generalization of psychological knowledge does not cancel, but use at maximum the accumulated knowledge in the field of psychic processes, properties, characteristics and mental states of Man. They become intelligible and objective and return to today's real practice in the context of terms, concepts, phenomena recognized and accepted by mankind much earlier than modern psychological terminology. However, one does not interfere with the other, and if this becomes clear, then they together explain the essence of human behavior in the modern world. And today this is very important for nearly everything. And, as a result, the picture of the world, beautiful in its simplicity and logic, as we used to believe, that is standing out not only before scientists, but also before all of us, is beginning not only to get distorted, but losing its logicity and, most importantly, clarity. The obvious is not only any longer understandable, but sometimes it is becoming elementary incorrect. And, as S.P. Kapitsa used to say: **"the obvious becomes incredible..."** But if this expression is transformed into what is happening today, I would say: – **the incredible becomes obvious.**

Chapter 4. The seamy side of simplicity

*The Truth is that makes the world simpler, but not that turns it into chaos.
The Truth is not that demonstrable.
The Truth is simplicity.*

The Universe is more amazing and wiser than the limitations of the past and present scientific assumptions about its constructive restrictive arrangement, all these previous theoretical inventions of the last centuries, relying on the old parasitic world view of people and entrenched in their worldview destroying violence over any kind of nature that rules out any view of true creative activity in the surrounding reality.

Man is created by nature in order to cognize it. Eternally moving to the truth, he is doomed to knowledge. But moving to the truth, it is important to understand today's objective multidimensionality of life, its multi-level and multilateral nature, the complex causation of actions and events, non-linearity and multi-variant development. Traditional concepts and scientific dogmas within the context of this new outlook are losing their significance and are going to be progressively supplanted by the original concepts created on the basis of the dialectics of multiplicity and representing the world around in a holistic and systems way. What Nicolai Levashov and Alexander Khatybov used to write and say and Nicolai Morozov used to dream of, while in the Schlüsselburg Fortress creating his prophetic scientific works, is taking place now. Our world is infinitely complex and incredibly amazing, and scientists in their research can not isolate themselves in the limited "scraps" of the methodological and theoretical space of individual sciences. The time of narrow specialization is implacably passing – one should be more daring in approaching the boundaries of the subject areas of knowledge, look for links with the adjacent subjects. The interdisciplinary integration of science and its globalization, in the broadest sense, are the trends of today. There can be no other way. Of course, understanding of the highest complexity of natural and social phenomena and processes should go together with the **NEW COMPREHENSION OF SIMPLICITY** as the "reverse side" of complexity, its "seamy side" and at the same time its fundamentals. Unfortunately, the events happening before our eyes make us admit that simple forms of socio-economic phenomena are less and less likely to be in the focus of the orthodox "researchers" attention. For some

reason, they do not understand that it is impossible to comprehend the complexity of the changes taking place without turning to their simple fundamental principles and First Cause. The simple has always been the basic element of real science and it must be reproduced in its modern neoclassical⁴⁶ advance. Turning to the simplicity of phenomena should be inevitable in the occurring theory foundations formation; it must be "inherent" even among the fundamental theorists. Now the tradition of analyzing simple forms of the phenomena under study has turned out to be mainly lost. But this is not surprising, because we already know how, why, and what for science "developed" in historical time, and what we eventually have come to.

The complexity that today's world demonstrates does not reject simplicity at all, it calls for a **QUEST OF A NEW SIMPLICITY OF THE COMPLEX SYSTEMS OF BEING**. The restoration of the methodological, theoretical and instrumental status of the simplicity is quite within the power of our scientists, not all of them, but those who are looking for the new and breakthrough, not getting stuck on in the framework of the so-called "orthodox" science with its postulates and "authorities". And in this I see the first "shoots" of the future crisis overcoming and the new prosperity of our own, Russian science. It is not at all the "pious feelings" of scientific policy pursued in the present-day Russia that consists not so much of the mechanistic transfer of alien institutions into the domestic environment, as the incorrectly chosen strategic priorities and means of their achievement. We can see how often and on the most different pretexts the state (or rather, certain personalities with the Brain genotype known to us) evades solving complex problems, combining this with bureaucratization and corruption, invented inflation and the resource potential devastation, the domination of quantitative indicators of development over quality transformations. This is not a clear simplicity of understanding the ways to achieve complex goals of effective development, but a simplification resulting from the lack of awareness of this complexity, leading to failures.

As an everyday occurrence, we see a long-time impoverished country, where the majority has been barely making ends meet, the primitiveness of views, the crisis of culture and, on the reverse side of life, ever so new salons,

⁴⁶ Neoclassical direction explores the behavior of so-called. economic person (consumer, entrepreneur, employee) who seeks to maximize income and minimize costs. The main categories of analysis are limit values.

clubs and boutiques of the rapidly “multiplying” millionaires and oligarchs, politicians speeding up in their armored-tinted cars with “blinkers” past the stupefied "common people"...



Simplification of the state social and economic policy inevitably results in its poverty. This poverty is manifested and aggravated in the spheres of informational impact on man, falling upon him in advertising, capturing in the standards of mass culture and fashion, gripping like a "screw" of an all-consuming aggregate of the market, inveigling into disbelief. Against this background of the seeming "hopelessness" **ONLY SIMPLICITY OF THOUGHTS AND ACTIONS BECOMES INGENIOUS AND FRUITFUL**, based on a deep knowledge of complexity and aimed at resolving the pressing problems of the objective and subjective reality of people's life. Precisely because of this the study of simple forms of various phenomena has to be revived and get a powerful theoretical base. The point is the proper philosophical, psychological and methodological substantiation, the formation of an internally logical system of categories, the development of a flexible understanding of the physics of the ongoing. Only after realizing and scientifically describing the simplicity of the society and the economy as the lower limit and basis of the progressive development, one can proceed to an objective analysis of not only the complexity limit reached by the people of our country, but also "beyond the limit" of their

current poverty. When you try to draw the face of the modern world, as it is seen today, if you rely only on the facts that are now in the field of vision of the majority of researchers and people who are just watching the events, then this picture seems rather sad. If current trends continue, if the nation does not take some active and purposeful measures, then the future does not promise us and our country any kind of prosperous life. Probably it should be said much tougher: if we follow the current course of events, extrapolate to the future the trends that we see today, then the people and the country can only expect further degradation, and in all directions – the economy, culture, moral climate...

In order to stop sliding into non-existence, the people of our country one day will be forced to realize the abyss expecting us, look into it and see the reality. In my opinion, it is all that is happening around us today that makes up this "mechanism" in our understanding. But this is also the condition for the possibility of simultaneously believing that not everything is lost, believing in ourselves, that we still have some supports, and this is especially difficult – after all, they **HAVE TO BE MADE OUT AND PROPERLY USED** under the conditions when the powers that be are not able or do not want even to think about it. Finally, people have to feel the community: we are not alone, there are many of us, we are a single people; to realize that we have a common fate, and something for the sake of which it makes sense to sacrifice, if necessary. Only in this case, people will be able to find courage in themselves (without which no understanding has any sense) – the courage to start living, following scenarios that are completely different from those we are following today, the scenarios to which life pushes us and which are far from being obvious. which are to be comprehended by all of us!

We do need truly new ideas, new plans and public discussions of the ways of the new Man birth and, as a result, the new Russia. Not the revival of Russia, which both "democrats" and "patriots" like to talk about, but the formation of the new Russia. "And where to start?", you may ask. There was time we talked a lot about this with Levashov and came to one thing – we **HAVE TO START WITH A WORD**. I am often asked to explain why the events are happening exactly this way, affecting the most pressing everyday problems of people who believe that there is "some kind of hopelessness", and not the other way – "we wake up and see everyone happy..." Exactly this I am writing about in my books, starting with the word and simplicity and trying to answer those questions that Nicolai Levashov and Alexander

Khatybov did not have time to answer. The study of simplicity should cover not only the sphere of scientific knowledge, but also those deep spiritual foundations of human life – the Faith, the symbols of which are embodied in its simple and clear life-giving values, but not in terms of religious perception. Against this backdrop, a new meeting with simplicity is truly important and necessary. However, its results should not "hung" in the sphere of the so-called "high theory". Our turning to simplicity and the comprehension of its "seamy side" consists in **RELYING ON OUR OWN** knowledge and our own current world outlook, to substantiate practical recommendations in everyday life, the field of understanding the so-called "today's politics", economics and, most importantly, the life support economy, culture, medicine and other things, which exercise the minds of those who should "turn around", first of all, in the direction of ordinary people of our country, and not only.

All the knowledge of mankind, no matter how diverse and surprisingly differentiated among themselves and within itself are like "spreading wide" fingers, with which man penetrates into the fabric of being. It is natural and necessary. But along with this differentiated approach, there is a need in a generalizing wise look (as if from a high mountain), imbued with philosophical mindset that takes into account psychological factors. The most serious today's necessity of man is the need to cognize the truth.

4.1. To live – and «there», too...

I think that the concepts of rightness and simplicity for each specific situation should be different. And each time they must be appreciated anew. There are no two absolutely identical cases as there are no two identical moments. Something is happening to us all the time, it is changing, moving and flowing. We know, understand and master something new. It often happens that things that once seemed right to you are no longer as good and true as before – just because we have become different; something has already changed in us; and because now we can look at them in a different way. There is nothing permanent in this world. Nothing fixed and definite once and for all, nothing that could not be changed. The only question is whether we are able to do it, whether we are able to change ourselves in order to do what we have to do? This is the basic thought. However, everyone has some thoughts, values, rules that one tries not to violate – they do determine

the attitude to these or those events. But in today's realities, as I am convinced, and, probably, not only me, sometimes they may let down. Therefore, it is necessary to rely not only on these firm convictions. And if you are talking with someone about something, try, first of all, to hear and understand the interlocutor (which is often very difficult). And if you don't like something in him, always think about why it happens, think about whether he's right about something, ***doesn't he see anything that you are not able to see at the moment?*** When you look at the mountain from the distance, it seems small and quite insignificant. When you are standing at its foot and raise your head to see the top, you suddenly realize that the mountain is not that small. And when you get to the very top and you see the tiny human figures in the distance, it becomes clear that you made a mistake in both cases, and that, in fact, you look tiny compared to the mountain, but you have the courage to admit it and conquer it, despite all your shortcomings. This is what most of us have to learn in order to know the "seamy side" of the simplicity and move on further in our knowledge.

We take for granted the fact that we have consciousness but we forget ***that much of what we see does not objectively exist***. For example, in fact there are no colors in nature – neither "red", nor "blue", nor "green"... This is just a reaction of our eye and the Brain to waves of light of a certain length. The interaction of consciousness and the material world no longer seems to be something fantastic today. Consciousness is energy in its subtlest and most dynamic form. This explains to some extent why our fantasies, mental images, desires and fears influence real events, how the image created by the Brain materializes. For all that, the rapid and global changes taking place in the world **HAVE CREATED A NEW PSYCHOLOGICAL REALITY**, which requires new concepts, hypotheses and theories for its explanation as equivalents of reality.

We take as a starting point the fact that with the introduction of the Brain genotype 441 all the control information was finally transferred to its own digital basis. With the introduction of genotype 442, the Control Complexes (the Caucasus and the Alps) formed a programmed individual and associated "programmed-objective" Mind, directing all the people of the planet ***not to the true objective reality, but to the artificially created by the System***. The program-determining substance of the controlled state of the Mind in its information base not only completely, but finally switched to its own imposed digital beginning. Some people in general have ceased to have any freedom in comprehension of the surrounding

"objective reality". The fact that requires psychological explanation is – the catastrophically few psychologically perfect people in everyday life and the dominance of psychologically primitive characters in society. The explanation – the losers are not familiar with the laws of behavior which bring to success "there". **"There" means in the artificial world**, where people operate with equivalents of real values of the natural world. **There are subjective "subordinate" regulations of behavior, and not objective laws of reality there.** The psychological realities of the natural world are among the eternal and absolute, while the realities of the artificial environment are temporary, changing. Man of the XXI century has to live "there" too – in the environment of money, advertising, elections, and this requires specific abilities, talents and personal characteristics. The ignorance of the psychology of the "man-power" system led to the unprecedented humiliation of people interacting with the macrocosm described by I. Kepler or with the microworld described by M. Curie. At the same time, the psychological characteristics of people working with the micro and macro world equivalents in the so-called "Gobsek⁴⁷ type" are made incredibly high. It is ridiculous – as ridiculous is the situation when a peasant who raised bread goes hungry because of his inability to sell and buy. And even more so, when an atomic physicist who solved the problem of supplying energy to the whole of humanity turns out to be impoverished due to the fact that he cannot speculate on the Stock Exchange or elect loyal leaders because of the pressure of political advertising. It must not be. And believe me – it will not be.

4.2. Disconnected thinking

Information is the equivalent of The Mind exactly the same as money is the equivalent of labor (as it's commonly believed). The cult of the mind began to be replaced by the cult of information after the invention of printing, communications, and then the introduction of its computer processing.

The betrayal of the creator's behests and now topical education system of Ya. A. Komensky: **"to cognize and research into the very things,**

⁴⁷ A man whose whole life is focused on the accumulation of wealth; self-interested miser.

but not just someone else's observations and testimonies about



things", resulted in the rise of the equivalent of the mind – information in its technical understanding and its interpretation in the media. However, on the side of the old System it was provided guaranteed ***isolation of people from comprehension of the true purpose of information***, the construction of its energy-information structure, its functional, semantic and its other hierarchy, the true transmission systems, reception, control, and much more. Simply "information was declared the First Principle of the Whole

of Universe" as the basis of everything. Not more and not less – as in religious philosophy. In fact, all the information formed by the System was endowed with only **TWO STRATEGIC FUNCTIONS – GOVERNING AND COGNITIVE**. The system, acquiring a stable form of control, provided an increase and consistent complication of the information flow transmission with each newly introduced Brain genotype ***or transition to a different level of the energy biogenesis development***. All information was subject to the results of their behavioral implementation in the being organized by them and for them. This is the answer to most of today's questions that people have after the change of the Control System in the recent past.

Information is considered to be a product of the Mind that accurately reflects the real world logic. And the society successfully consumes the information embodied in the systems of technical security of our lives. However, the Mind, which gives man a certain horizon of foresight, does not just complicate the process of self-organization – it creates certain opportunities for a new anthropocentrism⁴⁸, for purposeful impact on the evolutionary characteristics of life support system of man in order to keep its parameters within the limits necessary for further evolution. But the Mind is two-faced Janus: creating amazing possibilities, it gives rise to illusions at the same time. And perhaps the most dangerous of them, which today prevails in the so-called "rulers and controllers of fates" belonging to the

⁴⁸ Anthropocentrism is a Judeo-Christian tradition, according to which everything is created for man who God chose to rule on the earth.

well-known Brain genotype – is an illusion of permissiveness, independence of the society and of everything taking place in our habitat and environment. To use the possibilities and protect from illusions – this is one of the ideas of my book.

In order to cognize the manifested information, that is, received, translated, decoded, etc., each functional individual, especially belonging to the "Golden billion and million", **required certain primary knowledge, elementary systems encyclopedic readiness, gaining of real cognition at the current level of higher education.** And all this remains with them today. It is just impossible to take away by any means, and it is not necessary, but to change it in line with the required –it is a possible and real option – within the framework of the "**SvetL**" **Programs** application – with their help to "make" their Brain respond to reality in the right way. It is quite natural that the question should arise – if all the information had a tough targeted subjective selectivity, then how among multitudes of people were there formed actions and events that by their scale could involve tens or hundreds of millions of specific people in a short-time into some joint coordinated actions with a high degree excluding the chance of extraneous involvement? Isn't it really possible? And if so, how were the directions of such actions or events development including the civilization development control in general, shaped? That is what we are going to figure out with you.



The direction of development **is the execution of the programmed functions or sequence of commands according to their semantic hierarchy of different levels**. Their implementation is inevitably through **SENSIBLE OR IMMANENT**⁴⁹ **MANIFESTATION** and the given hierarchy of mandatory actions that inevitably bring to the planned events envisaged by the Target Vector of phenomena, actions and events for a specific period of time. Without an executing state of cognition, such a process cannot take place at all. It is possible to form information flows of control functions of any density and capacity, but if man does not know what, how and what with to do it, he is unable to execute the command, since it will not be comprehended by him, with all the consequences of this. The same principle remains true today. And the same principle is "laid" in the ideology of the **"SvetL" Programs** for their interaction with the owner's Brain. The direction of development, as well as the beginning and duration of the executing process, are determined by the programmed purpose on the side of the Control System; and the information performs the function and role of the instrument by which the control of the executing processes and the efficiency of the actions and events execution are carried out. However, the information makers themselves shared the fate of the peasants, **whose grain was replaced by paper money (by the equivalent): THE SOCIETY BECAME TO VALUE NOT THE MIND, BUT ITS EQUIVALENT – INFORMATION**. So, money devalued the burdensome process of peasant's product production, the same as information **devalued the tormenting process of thinking**. Who of the scientists, and not only them, does not know how insultingly cheap the product of the exhausting intellectual work is valued by the customer? The modern society raises not the creators of bread or thought, but the owners of their equivalents: money and information. Information really has psychological signs of the Mind, but it is easily distorted into its opposite. For example, a sign of objective information is based on reliability and completeness, proven by scientific methods. But it is successfully falsified – it is forged, distorted, the genuine is replaced by the false. In the information

⁴⁹ Immanent (from the Latin. Immanens, – abiding in something, peculiar to something) – a philosophical concept denoting something, being and acting within the subject, not directed and not passing outside; corresponding to the nature of the object, inherent in it, and not brought from outside.

space, ***there reigns the phenomenon of cognitive⁵⁰ counterfeiting.*** This is not harmless, since falsifications give rise to delusions – wrong, not consistent with the true state of affairs judgments that are imposed on people. Another sign of the Mind – the systematic nature of information, which orients to all directions of reality, began to be replaced with disorienting information. Such a replacement generates overvalued ideas that are not clearly absurd in nature, but acquire great significance, which they really do not deserve. Information organized by the rules of science is replaced by demoralizing information. Such "information" provokes a "leap of ideas" – a violation of the sequence of conclusions, statements, fragmentary, chaotic, unfinished thoughts. There are many who have come across this today, not having yet comprehended all the destructiveness of such. The sufficiency of information is replaced by entropic information leading to the development of the phenomenon of the "idee fixe" – which man wants to get rid of, but can not. Readable information is replaced by disinformation, which gives rise to "incoherence of thinking" – the correct perception of particulars, but with the loss of the ability to draw logical conclusions and synthesize particulars into the whole. Specific information is replaced with disorganizing information that leads to moralizing – absolutely empty words, poor in thought statements, clothed in an ornate, but correct grammatical form. Practical information is replaced by corrupting information, gives rise to the phenomenon of disconnected thinking, where concepts and ideas are combined with each other on the basis of random or formal signs. The necessary information is substituted with disintegrating information followed by compulsive ideas – absurd thoughts, senseless actions, which, however, are beyond doubt because of the conviction that it is impossible to act otherwise under the conditions created. Many people today, ignoring or just having no idea of the psychology of the Mind, perceive informational "fakes" in the usual way – as a credible reflection of the laws of the real world, which they studied in their fields of knowledge and which the available sources of this information are now full with. Today, no one perceives so trustingly disinformation, falsification, discreditation, etc., but so-called intellectuals. And no one follows it as persistently as they, continuing to spread it all and believing that this is for the "education" of other people – because they have no immunity to lies. As

⁵⁰ Cognitive (Latin *cognitio*, "cognition, study, awareness") is a term used in several rather different from each other contexts, denoting the ability for mental perception and processing external information

part of the development of specific Brain genotypes, it was just destroyed initially, and now all this will have to be restored both by the people themselves through their cognition, and using the created and tested technologies for the Brain development, which have already been told a lot, but still much remains to be told.

4.3. Kitsch – the equivalent of the unconscious

In addition to the undoubted achievements of psychology of the unconscious, for example, in medical practice, in the sphere of entertainment, it is involved in an unprecedented phenomenon – the spread of mass kitsch⁵¹: immersion of man into the world of nonexistence, but presented as real. Technical achievements allow realizing psychology of the unconscious in the form of the "world of shadows" by the methods of photography, cinema, television, sound and video recording. ***This fact*** is astonishing: people satisfy their curiosity, excite their passions, spend money and time to get satisfaction from running an electron beam on the luminous screen of the kinescope. Light spots on large and small screens ***mesmerized millions of people more powerfully than any previous religion or drugs***. All their free time, mental strength and



resources, many people waste on worshipping the sound of the nonexistent and depicting the imaginary. The total time spent by mankind at TV screens during the day, is much more than the time spent on ensuring their own existence in work! This is explained only by the fact that the introduction of digital technologies has taken place at a high rate in almost all areas of the organization of human existence, that is, all control information has been transferred to its own digital basis definitively.

No less striking is ***another fact***: a lot of people replaced living man contacts, his body,

⁵¹ Kitsch (Kitsch) (it. Kitsch – hackwork, bad taste, "cheap") – one of the earliest standardized manifestations of popular culture, characterized by mass production and status value. Focuses on the needs of commonplace consciousness.

his thoughts, his feelings, with the contemplation of a flickering screen. Moreover, when contemplating light spots, they get satisfaction similar to that with a real object. There appeared a new kind of behavior of a "fan", "spectator", "observer", which is not able of any deed, venture, or an effort of his own. By the way, interaction with real people is the final link in the process of personal tireless work on one's perfection: the higher one's own perfection, the shorter the way to people. In case of a lack of psychological power, its reality is replaced with magical technical surrogates.

The third striking fact: people get some technical opportunities to supposedly hear, see those people who have long been gone. The possibility to emotionally, mentally communicate with ghosts, shadows more confidentially than with real people has gained phenomenal popularity. The famous "Ghost" from Shakespeare's "Hamlet" is nothing compared to the magnetic voice of long-dead singers, actors, writers, politicians. Many citizens can not always surely say whether the person whom they listen to, watch, sympathize with and believe is alive or not! Living public, intellectual and emotional leaders have to compete with the shadows of famous authorities as if they are alive.

The fourth fact: the content of kitsch is the expression of the impossible. The technique allows you to feel the flight to the stars, shoot another man with impunity, watch the scenes of friendship of a wolf and a hare, a friendly conversation between a torn boot and a pig, ***i. e., everything that is physically, biologically, psychologically impossible, which does not exist, which contradicts the laws of the society's nature.*** Understanding what is happening in a figurative, metaphorical sense has nothing to do with it here. People constantly find themselves in a situation where it is not clear: what is asserted as truly existing, and what is presented as the "product" of art. Advertising has the power of suggesting to its audience the presence of lacking qualities in the advertised product. Political advertising awards the leader with virtues that he does not have. This magic is so fascinating that crowds of young people leave the world of real productive labor, rushing into the bustle of the kingdom of shadows – to the theatrical stages, film sets, television studios, recording studios and advertising agencies. As a result, a gigantic global kitsch market was created – **OF PRODUCTION, BUYING AND SELLING OF NON-EXISTENT, IMPOSSIBLE AND UNREAL.** Kitsch is paid, bought and sold, it helps to vigorously influence people's behavior. In the sphere of kitsch production a tremendous mass of people and money

are moving, incomparable to the money, which are aimed at creating a real product. Kitsch allows man to feel warm when he is cold, to take disgusting for beautiful, terrible for funny, to feel full when he is hungry: the reality is distorted in any planes and dimensions. The inability to produce material products mobilized the production of unconscious sensations to derive pleasure from the consumption of non-existent products. Thus advertising has become more expensive than the product, ***the product of the Mind has become cheaper than the product of the unconscious***. The world of kitsch is not so simple and accessible: in the world of shadows, in the world of kitsch they live by their own laws, they have their own psychology and their psychological virtues. You can not overestimate the influence of psychology of the unconscious. Since 1991 Russia within the framework of the execution of the System program, has been plunging into the darkness of the sacraments: commercial, banking, medical, investigative, financial, party, religious, technological, etc. In this mysterious darkness state and unknown services, societies of Satanists, organized crime, sects are functioning as equals. They "transfer" goods and monetary flows by unknown ways, transform natural bread, metal into "securities", etc. Almost no one knows the names of the "pilots", authors of political campaigns, bills, advisers and astrologers of the state leaders. The country has become the embodiment of one big mystery within the framework of the imposed kitsch. In Russia, there is less and less room for scientific methods developed for studying the real world. And there is less and less room for people adhering to psychology of the Mind, because the situation in 1990–2009 (I remind you – stage 5 of the digital information civilization of human development by bringing into an active state the California Control Complex (1990) and introducing Brain genotypes 461) modern "sociologists" and "rulers" defined and qualified as the introduction of an advanced experience in building a new social construction on a liberal-democratic basis within the framework of the same kitsch. This treacherous naivety and "cunning" simplicity sounded for the illiterate



controlled class, that is, for the common people, very tempting and grandiose – liberty! Against this backdrop, the state ideology is completely absent as a deep-seated mental image of the entire worldly understanding for an individual and society, life orientation in one's individual and social development. With the help of the created and imposed kitsch, it was faked for some non-existent "freedoms" in the world of violence and parasitism. But it should be especially emphasized that no liberal-democratic ideology exists and could not exist, **since every ideology is the program of the control produced by the System, but there was no system.** It was just a short-term transition process, as preparation for the new ideology transition. There were no reforms in general or scientific research in the field of psychology and sociology during this period, there was just a process of destruction of one state of structures and the preparation of conditions for the transition to another state of the control structures. We can say that science and the people were just neglected and forgotten during such "triumphal changes". Toughly, within the framework of the same kitsch, new standards of behavior that yesterday were considered criminal, focused only on the legalized priority of corrupting vices, impunity and permissiveness of the minority from the managerial class, open bureaucratic opposition to solving any kind of social problems, began to be introduced. The character, scope and systems nature of such sophisticated forms of violence suggests that **SOME GLOBAL SECRET PROJECT** of civilizational collapse and the complete destruction of the familiar world of people **IS BEING REALIZED**. In fact, this is not a secret project, as modern publicists are trying to present it, **this is THE SYSTEMS IMPACT ON THE LIQUIDATION of the man-made incarnated old Construction of a violent and parasitic being of an inessential minority.** In addition, we should not forget that the interventionist System (through the programmed framework of the Target Vector) determined hidden from people functions that directly influenced the entire social order: to improve the illusory nature of liberalism and democracy in societies, permitting abstract activity and liberty in everything except control and penetration into the scope of Structural power to anyone unrelated to Brain genotypes **42** and **44**. I think that it is already clear to readers. The representatives of Brain genotype **44** were to to head the Non-Structural (public) power, securely isolated it from any interventions and penetration into the function of "the might of power and the power of money". This is what we are "reaping" in full today. By administrative and organizational methods and technical means, through the construction and imposing kitsch everywhere, there

have been insured information isolation from the high-level knowledge. Other Brain genotypes (not related to **42**, **44**, and **46**) were to be brought to mental, spiritual, psychophysiological, and physical degradation. Is there anyone who will try to argue that this is not so? As a result, man today is at a crossroads – either complete, including intellectual degradation within kitsch as an equivalent of the unconscious, or unparalleled evolutionary leap of consciousness in cognition. But man himself should decide, through the opportunities that are open for him today and go on opening.

4.4. Mummery is an equivalent of faith

We have already talked a lot about faith, but it makes sense to come back to this due to the present state of people and for their understanding. ***In fact, faith is the core of a personality.*** The personality development is such a laborious process that most people give up doing this. So, many of us stop writing verse at a young age, finding it too difficult. Not believing either in devil (if there is a concept of devil), or in God (if there is a concept of God) man can never become a personality. However, the applicant for the position has to meet ever growing requirements for the personality. The applicant for power, position, status ***should, above all, manifest high personal qualities.*** Few people think about the fact that the personality components: direction, strength of character, control of one's temperament, realization of one's abilities are the embodiment of man's faith and strength. It is faith which betrays an outstanding personality that inspires confidence

in people, positively characterizes his stability and reliability. It is **FAITH THAT IS THE FRAMEWORK** where personality's pride "is attached". The influence of faith is so strong that for the sake of it some people mounted and still mount the scaffold. Outstanding personalities such

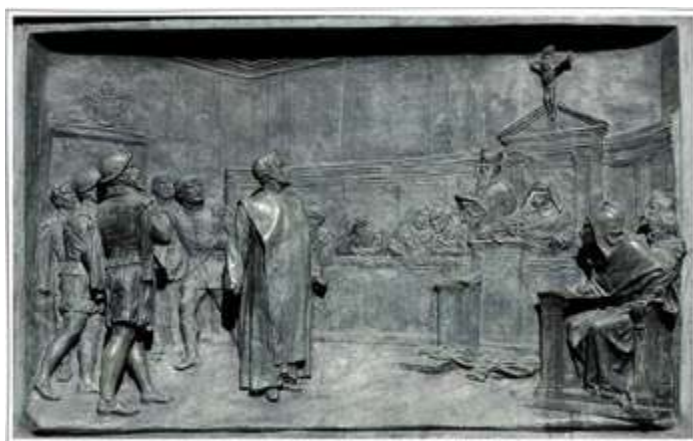

as Giordano Bruno deliberately died believing in the scientific insight, personalities such as Magellan overcame the oceans believing in the truth of their knowledge. I am sure that the reader knows these names. Faith cannot be bought, appropriated, invented – it takes possession of man and controls

him up to complete self-denial. In view of an extraordinary difficulty of finding faith and at the same time of its being mandatory when performing certain functions in the community, it has practically been **REPLACED WITH AN EQUIVALENT – THE MUMMERY, a skilful portrayal of the natural characteristics of an individual**. But according to the program the organized being of the whole community was to have such constructive characteristics, in which only individuals of Brain genotypes 42 and 44 could not only apply, but also necessarily improve through their life experience, the abilities that were imposed on them, including faith. For all that, they had to "present them in practice to the entire world community" as mandatory and indispensable conditions for everyone else. Through practical influencing actions of such specified people, the control of all the programmed executive accomplishments, including faith and mummery occurred, and we usually call this the civilization development. It was through them that the development process took place, and they were the main transmitters of faith in accordance with the "historical" moments, **and all the others absolutely implemented everything that was "imposed on them" by the System, as the program FOR ALL THE REST TO PERFORM**. This applied to all possible existing spheres and conditions of people's life, and if those did not turn out at the historical moment, then it was artificially organized, including the spheres of faith or mummery. It was envisaged and supported by the program.

Historically, mummery was the occupation of wandering actors and was not highly valued. It was considered vicious to show those qualities which man did not possess. And if the quality was presented, then it had to be confirmed in real behavior: in a duel with a weapon in hand, in a scientific dispute, in the conquest of unattainable depths, heights, spaces. The bearers of unshakable faith, giving strength to their personalities, were N. Copernicus, D. Livingston, DI Mendeleev, A. Suvorov, etc. However, life in an artificial technospheric environment has changed so much that today many people can hardly remember the names of heroes- cosmonauts, but they will surely name outstanding actors.

We have to accept that the scientific and technological revolution has removed the problem of direct contact with the physical environment for many people: they contact with it through technical, informational, service systems. And this removed the problem of confirming the required qualities – it is enough to present the secondary signs of faith (personality) in dress, manners, form of statements, etc. This was the beginning of mummery

spreading from the theatrical stage into public life. The signs of faith are presented in the form of "documents" and "certificates", replacing the actual deeds for the sake of faith – faith in moral values, in the power of scientific knowledge, in the possibility of improving man and through him – the society. In psychology, mummery got the form of various trainings, which began to teach "to look", as previously they taught to feel, see, think, understand, act, endure. Instead of developing primary natural qualities through hard personal labor and extreme trials, methods of various trainings taught to portray the secondary qualities of man and signs of faith in certain values. All this is a consequence of the imposed programmed "skills" from the Old control system in the development of human Brain genotypes. For modern political life, imagemaking, political marketing, electoral technologies, which are the technology of imitation of the required personality characteristics, have become a problem. The reasons for this are clear. People living today, **WERE FORCED TO LOSE THE HIGHEST VALUES** – mutual respect and mutual confidence, the respect of family and parents, the preservation and observance of social values as the legal basis of society, strict advocacy of personal values, including human dignity, preservation and respect of cultural and ethnic values. And this value disaster occurs everywhere. I don't remember that I have ever come across an autobiography, a description of someone's life or a fiction work, except for the authors already mentioned in my books, where the truth would be told as it was. All of us have to be hypocrites to this day, wheeler-dealers and liars to the end of our lives, unfortunately. We can not but play a role before each other, just as we can not go out naked. We all believed and go on believing that this is normal, and it fits into the image of our life and our thoughts.

Today, all countries (territories) and people living in them differ from each other only by the rate of collapse, the level of concealment, false state value declaration or ethno-geographical and other particular features effecting in one way or another the approaching value catastrophe. All this considerably confused people's understanding. However, understanding of the ongoing events does not mean that they have some sense. Even today, the representatives of the once-leading Brain genotypes in auto-motor-like way go on fulfilling the "biblical prophecies" laid in their Brains, but in the absence of life-support transmission, all attempts to manipulate people and mummery on their side are in vain, and bring to completely unexpected results for the former decision makers.

4.5. How much are kings?

Will, like Mind, is a very hard man's virtue to attain, which is gained by his own, often uttermost efforts. Far from everyone, this virtue is granted to people – the ability to act beyond the limits of one's organism, common sense, rational advantage. For various reasons, many people either do not even start the process of will training or give it up due to the intolerable difficulty of this direction of development. Meanwhile, without volitional qualities, no success is possible, and naturally there comes a desire to replace the will with some easily gained equivalents. ***These searches resulted in a unique invention that fundamentally changed the direction and character of our entire civilization: the emergence of money.***

Just as information makes it possible to preserve, transfer and purchase products of the Mind, so money allowed storing all the efforts of the society and specific people, even whole generations. **AN EQUIVALENT OF WILL IS MONEY**, such a social tool that makes it possible the will to be conserved, accumulated, borrowed and set going whenever there is no one's own strength to overcome an obstacle.

Everything was done so that man from birth believed: the main social and psychological essence of money is that it guarantees to any of its owner to overcome obstacles at any time, in any place, in any condition. Money wins real courage, determination, endurance of opponents, because in it there



invisibly accumulated the will of not one man, but tens, hundreds, thousands of people, of course, depending on the amount of money. A man with money in modern civilization has the same absolute advantage over people without money, as in an ancient "pre-monetary" times, a strong-willed man had over

weak-willed ones: he could afford everything and everywhere. Money, as an equivalent of will, absorbed all conceivable human motives and tied them in with actions that man with money can afford. For money any information is bought, any kitsch is created, any most perfect mummery is ensured, any actions are performed.

Classical psychology, of course, propagandizes training of volitional qualities, but it has never even considered the probability of its equivalent existence. Therefore, a great number of educated, intelligent, strong-willed people know little about what money is, do not know how to handle money, use money, they are not interested in the mechanism of money work. Many very intelligent people are satisfied with money definition as an equivalent of labor invested, not seeing their deepest psychological essence.

Meanwhile, there are many people who independently, in any case, without any support of the scientific system of psychic development, got a good idea of psychology of money and effectively used this knowledge in a specific way for specific purposes. Here I will quote Honore de Balzac, describing the omnipotence of the bank (money): "***This is a place where it turns out how much kings are, where the value of peoples is weighed on the palm, where systems are judged, <...> where ideas, faiths are indicated with numbers, <...> where God himself borrows and guarantees his income from souls, for the Pope has a current account there. If I can bargain my soul somewhere, then it is there, is not it?***"

Let me remind the readers the whole picture of the financial system formation from the very beginning to the present day. In 1605, Brain genotype **421** was formed. Simplified forms of barter were introduced. This period took almost 9 centuries, from **882 BC to 0 AD**. Under the control of the Kazbek Complex (the Caucasus Control Complex), Brain genotype **422** was formed. From that moment, using the experience of the previous Brain genotype, there took place an energetic process of actively teaching the whole population to worship the "power of money", the prevalence of material values over the human spirit and the truth. With the introduction of genotypes 441 (from 1433 until 1841 – the third stage of the digital information civilization of people's development), there began an active development of the barter rules and laws, the basis of the whole barter began to shift to the value of the produced substitutes⁵² everywhere. The process of a substantial increase in its volume, gaining its leading significance in the field of finance were activated, thereby playing ***an impetuous role in dramatic development of violence*** both in the field of control and

⁵² Substitutes (from the Latin. Substitutio – replacement) – interchangeable goods or services. Interchangeable goods (substitutes) – goods or services, in which the increase in the price of one commodity causes an increase in the consumption of another, a decrease in the price of one commodity, makes another commodity less desirable for consumers, all other things being equal.

organization of people's existence, and the methodology of values in particular.

The community received an impetus to the banking development. The start of its development made it possible to proceed with the intensification of the process of the organized financial system formation and bring it to the state of complete control by Brain Genotype **441** with the involvement of specialists of other genotypes, neglecting all previous material priorities. The control, possession and application of the substitute in circulation was fully taken up by representatives of Brain genotypes **441**. The indicated genotype, as the leading executor from the Conceptual Power, in a short period managed to gain special control functions in the society, disregarding all sorts of legal norms, and seize the proprietorship and control in everything related to people's being organization, completing the process of imparting "the power of money" a particularly significant **AUTHORITATIVE FUNCTION OF THE CONTROL PROCESS**. With the introduction of Brain genotypes **441** (1433, the Alps Complex 1), the entire historical picture of the development and use of money began to change significantly. For a short period of four hundred years, the System carried out a substantial correction of the Control programmed processes which led to significant changes of the executing states of the leading genotype and created for them executive circumstances. The main executive circumstance for the leading Brain genotype was manifested **THROUGH THE INTRODUCTION OF AN "INTEREST"** into the sphere of their implementing actions and events. Rehabilitation of the "interest", called "rent" in another way, turned out to be very simple in itself: *having called rent, that is, interest, a "scientific" phenomenon, it was immediately accepted as legal by some order from above!* Since 1800, for several decades, the entire planet with its inhabitants has already been completely tied up with a web of rent debts to the individuals of the leading Brain genotypes **441**. It was through the individuals of this leading genotype that a special technology was imposed to control the executing actions of all people and to exercise a special kind of violence against them, implemented through their financial colonization, brought to such an unconditional level of awareness of obligation and state of guilty and its inevitability, under which complete humiliation of people was achieved before financial usury and its organizers. Before such a state of general and financial control, in particular, even traditional state foundations throughout the planet, which brought to transfer of financial power from the hands of the state to usurers, shook

down, which I detailed in previous chapters. ***The methodology of values "People of value" has passed into a special phase – "economic man"***. With genotypes **441** there began the process of money revenge, i. e. "Financial revenge". I draw your attention to the fact that from that moment, that is, from the introduction of the produced circulation substitute as the basis of financial value, into the methodology of values "People of Value" there was laid a secret world mine into the future, which in subsequent phases of the world history would be realized through the Power revanchism and Financial Fascism. With the introduction of Brain genotypes **442** (in 1841, the Alps Complex 2), the System made a subsequent important control correction for the implementation of the programmed processes related to the subsequent stage of the Brain genotypes development. Financial revanchism, organized as a programmed system, just started to gain momentum and was still unable to take full power through the "power of money", it took time, greater legitimacy and scale. With the introduction of new Brain mantis the System through its Control Complexes, including the Alps 2, created all the circumstances to ensure the necessary volume of accumulation and concentration of the financial resources control and of the circulation substitutes **IN THE HANDS OF THE FUTURE "GOLDEN MILLION"**. General and particular objective function were predetermined by the Target Vector and, through the executing state of people were manifested, which resulted in the stage-by-stage reconstruction into the state of a single global finance system, centralizing the accumulation by groups of genotypes **42** and **44**. They were in an inseparable unity with the preparation of the executive basis of all programmed control processes of the authority sphere, to the transition to a unified structure of world governance. The formation of the primary basis for the realization of the world control structure and the new world financial system structure were imposed to execute upon Brain genotypes **442** with the assistance of genotypes **423**. Genotype **442**, endowed with special functions, had to perceive, comprehend and adapt the surrounding objective reality **PROVIDED TO IT FROM OUTSIDE** and only in that program-target format, as predetermined by the Control Complex. In other words, no matter how "talented" V. I. Lenin could be, ***he was not able to comprehend and organize the primary basis for the future global financial system.*** So the Rothschilds could not have done anything in the programmed processes of the revolutionary reconstructions that were implemented by V. I. Lenin. There could not be any mess in the executive processes, since man, or rather, an individual of this level possessed the

controlled state of “necessity” characteristic of him only. The revolutionaries-mentals⁵³ had their own specific directions for gaining the programmed state of "necessity", *the fondo-mentals*, a new generation of world financial money-grubbers under the "power of money" program, that is, the Rothschilds had their own programmed states of "necessity". At Easter of 1946, the System made significant programmed corrections of the entire control process through the Target Vector of phenomena, actions and events, including the envisaged principal processes – to bring controllability of the World Financial System, organized on the basis of the introduced derived values from a conventional circulation substitute, into a state of target harmony with the basic fundamentals of the World Control process in the interests of linking into a single controlled state “the power of money and the might of power” to complete the preparations for the transition to a new stage of development. By the end of the fourth stage of the digital information civilization era of people’s development (from 1841 to 1990), the most important qualitative leap was gained by the World Financial System, which *switched to electronic controlled accounting and electronic money everywhere*. It (money) in turn, began to gain some properties of independence from the nature of application of the provided substitute volume. Thus, the cumulative and technological preparation of finances for the transition to the next stage of the Brain genotypes development was completed. The Alps Control Complex (the Alps 1 and the Alps 2) completed its perfection. By the end of 1989, it had fulfilled the final stage in the formation of the “Golden Billion” (Brain genotypes 44). As a result, a stable dominant power-legal and social position, full control over the basic material values of the planet, including the circulation substitute were provided and supported by the representatives of Brain genotypes **44** and partially **42**. During the 5th stage of the digital information civilization era of people’s development (1990–2009), and the introduction of Brain genotypes **461** (the California Control Complex, 1990), it should be noted with regard to Russia that the Target Vector of this short stage envisaged: the controllability of the World Financial System organized on the basis of the introduced derived values from the conventional circulation substitute, was to be transferred to the state of target harmony with the basic foundations of the programmed World Control process in the interests of linking into a single controllable state of “the power of money and the might of power”(“ flooding

⁵³ The mental is a kind of energy produced by a person during intellectual activity.

the country with dollar and dependence on it of all resource values), ensure gaining the function of the entire proprietorship of all resources by the individuals of the "Golden million". For all that, everything was carried out under the control and intervention of the "representatives" of the Super-Judean priesthood. Financial fascism gained its full programmed essence and manifested its power. This accounts for the fact why exactly the people we know became billionaires. Exactly these names and not others. However, in the period up to 2009, for several reasons, serious system failures occurred in all the Old System Control Complexes. In its information base, the program-determining substance of the control state of the Mind finally shifted to its own introduced digital principle. ***Some people have ceased to possess the framework of freedom in the perception of the surrounding "objective reality" in general.*** All individuals of Brain genotypes **42, 44** and partly **46** are subject to this state. From that moment, a special stage of the methodology of values of "People of value" started up – "Financial Fascism". The main executors of the control program "Financial Fascism" are the three embodiments organized for this center: ***the Rothschild group, the Rockefeller group and the Vatican.***



The final results of all the events, associated with "the Finance" control program and the practical implementation of its governing imposition through the executors actions, was the embodiment of the global Construction of financial violence – the World Financial System. It was the last missing element of the future common Construction of the organized world community being established (according to the programs of the Ebr

System), which **by December 2011 should have completed the general process of the entire basis formation for the transition to the new stage of the control by the old system – "the Golden Era"**. Upon its completion, it was envisaged to introduce the states of the dominant control in the world through individuals of Brain genotype 46 – the "Golden Million". It has not taken place.

"And what is in Russia? " – you may ask. **RUSSIA HAS NO MONEY OF ITS OWN**, since the current "**Banknote of a non-existent Bank of Russia**" is a hidden form of an indefinite "dollar", and this is exactly that administratively thrust from outside "sacrament" which was imposed by the domestic liberal democrats during the liquidation of the Communist-type Civilization in Russia and its previous methodology of values without creating a new one in return. This is the main conclusion for today.

As a result of the neoliberal reform that was carried out, a specific structure of the Russian Political System with the "new" elements of the authority of "pro-Western control and influence" took shape and started up, independent of people's will. At the same time, a "modern" Financial system of a pro-Western profile with the corresponding structure of subordination to the World Financial System has been created. This was facilitated by three established control states:

- complete isolation of the State from the issuance and primary accounting of money in paper and electronic form with the transfer of this function into the sphere of private ownership, not subject to the state interests and legalized by the anti-popular law (the Law on the Central Bank of the Russian Federation);
- the created Financial system of Russia of a pro-Western profile within the framework of the complete subordination to the World Financial System guaranteed stable conditions for the country's financial colonization by the World financial capital;
- **sustainable predominance of the target orientation of the government officials' thoughts and actions** on personal benefits instead of the required state-public usefulness of their functions, and imposing on everyone else the disadvantaged way of life with their complete isolation from the financial sphere and opportunities for legal gain.

People finally ceased to belong to themselves through intangible money. This is the cause of global theft, corruption and permissiveness

occurring before our eyes. Today, the Financial System of Russia **HAS TURNED OUT TO BE ABSOLUTELY DEPENDENT**. Thus, it is deprived of the control state – "To produce Money" (not to be confused with the process of printing money as pieces of paper or filling the biased financial ether with electronic void of formalized accounting, controlled from the outside through some kind of private structure in the form of the Central Bank of the Russian Federation).

The present statehood construction according to the Western stencil model **HAS TO CONTINUE KEEPING** the subordinate dependent executing function of Russia before the **ALREADY NON-EXISTENT** world "power of Western empty money" and the liquidated "world might of power". But the inactive world power, presented by the former program function on the side of the former Super-Judean priesthood and the World Financial Oligarchy, continues, through various tricks of the "World Market", to claim from Russia its values to fill up their financial void. ***The current state structure cannot put an end to this.*** Taking into account the new functional empowerment for Russia, there is an additional preventive strategy – Recreation of the legitimate independent control state of another Financial System, previously lost in Russia, which has an autonomous provision ability of Money Production. Gaining such an equal right ***is aimed at imposing effective elements into the new World Financial System*** and transforming the functions of money into the supporting creative direction instead of the former functions as an instrument of violence. It can't be otherwise. This is already being realized through specific people, but in the framework of the System process, which does not depend on the opinions and influence of people.

4.6. Another value of "values"

For a more complete understanding of the ongoing events, a historical episode of the beginning of Perestroika in the USSR is of some interest. It is inexplicable to this day "some kind of impact", passed by an all-destructive wave in all areas of the regulated social and spiritual life of the peoples of the great country, having a unique immunity of survival under most hard conditions of the surrounding resistance — how and why has the "Civilization of the communist system" collapsed? But this destruction, with varying degrees of diligence, was carried out by everyone, without exception,

even individuals with "particularly red party cards", who previously possessed the granite crust of the communist worldview and the corresponding humane public consciousness! Where has it moved from the head? Up to now nobody can explain this from the "materialistic" positions of the world outlook.



When the leaders of the CPSU, headed by Mikhail S. Gorbachev, began the reformation of the USSR, psychology of which I am writing in this chapter was involved in a "practical" policy at the level of operative and tactical psychology: in spontaneous and senseless meetings, unauthorized demonstrations, aggressive elections and so on. At first glance, all this may look like an inadequate intent, like an unverifiable nonsense of irrepressible fantasy. And only from the standpoint of *the methodology of the energy-information dialectics* of the current stage of materialistic idealism – this was only **AN ORDINARY PROGRAMMED PROCESS** of the interventionist Control System and nothing else. But at that time, at the level of everyday understanding, there was developed a theory of mass political phenomena, political society, political man, psychological and political states, etc. directly in the "process of those events". These so-called "scientific constructions" were practically used in the school of intensive training of new generation politicians in Dunes near Sestroretsk in 1986–1989, then in the Aspen Grove in the suburbs of Leningrad in 1989–1991. I

was a student of such a school in the Aspen Grove in 1991 after changing military service for the state one. It was the time of formation of the Russian Federation Presidential Administration. And of course, neither I, nor any of the direct participants in those events and those who taught us had any idea about the methodology of the energy-information dialectics.

One of the consequences of the “involvement” was the formation of the first in our country political psychology department at Leningrad State University (now St. Petersburg State University), headed by Alexander Ivanovich Yuryev – doctor of psychological sciences, professor. The formation of this new scientific direction at that time was related to the processes of wide democratization of public life and the need to hold elections to the legislative and executive bodies on an alternative basis. I want to note here that much earlier in the USSR attempts were made to psychologically describe political processes and politics as science, but **IT HAD NO SUCCESS** for reasons beyond the control of the authors (V. M. Bekhterev, 1923; B. D. Parygin, 1966; B. A. Sherkovin, 1973; S. K. Roshchin, 1980, etc.), within the framework of the ongoing events, it was just too early.

From the first steps in this direction it became obvious that the "mass meeting policy" with the destruction of monuments, discrediting authorities, disorganization of management, disorientation of the society, demoralization of law enforcement bodies, disinformation of the population, falsification of history, disintegration of the people and the state does not justify itself. The senselessness of the "mass meeting policy" is explained by the fact that by 1991, the USSR rapidly "completed the ascent of the tree of exodus" of its historical fate and was faced with the choice of moving along one of many branches into the Unknown, which was unknown to almost everyone at that time, and therefore no one could tell how many of these exodus branches were, what were they like, which one to choose? It is clear today that **EVERYTHING WAS PREDETERMINED BY THE PROGRAM** of the target Vector, and that time no one had the faintest idea about it. The former System, completing the development processes of Brain genotype **44**, was preparing to transfer the program control processes to a different state, i.e., to the next stage of its development – *the "Golden Million"* by introducing Brain genotypes **461**. The main server to control these processes for Russia *was the object located in St. Petersburg.*



On the side of the System, through the correction of some elements of the control at the Complexes the following was envisaged by the Target Vector: the completed programmed processes of development of target spheres of capitalist and socialist being **WERE TO BE TRANSFORMED INTO A SINGLE CONTROL STATE** with the corresponding social changes built on the liberal-democratic basis of the entire authoritative sphere for the sake of stabilizing the World Control with the leading role of *the "Golden Million"*. The impact on people of the processes of energy-information support of the old system was exercised with the purpose of imposing such information that ensured the formation of public consciousness: *liberalism, communism and fascism*, based fundamentally on the relevant principles of their world view "I", "We" and "social parasitism in three modern forms of violence". I note that the dilemma of who is more effective in copying with the world is an individual "I" or collective, that is, united "We" is one of the central points of difference between communism and liberalism.

The final process of the completion of the "bright future construction" under the control program was to bring only to the state of complete predominance of the fundamental world outlook "I" over "We" in all complex processes of the public consciousness formation. It was to be completed before December 22, 2012, i. e., by the time of changing general program control processes on the side of the old System. Exactly from this final state of the general process of the civilization development, as a complete executing step, all the event processes were to go to its next state *as a separate control program – "the Golden Million"*. It was from

this time that people began to talk about some kind of "golden million", true, it was associated with those names that were getting richer and richer before everyone's eyes, without even hiding their deeds that "enriched" them. This is how the so-called "social consciousness – fascism" manifested itself.

It is advisable to consider, from a psychological point of view, what fascism is, the origin of which we mainly associate in historical terms with the events of the early 20th century in Italy and then in Germany. This is, first of all, the governing program phenomenon of information making (The Control Complex Alps 1), **embodied through ideological methodology, including the psychology of people** in its final aspect. This information in its main impact was focused at individuals of Brain genotypes **441** and partial use of genotypes **423**, but functionally was presented only as information of the governing nature. Its cognitive component, as opposed to "liberalism and communism" support, was altogether missing. Exactly for this reason, the so-called formation of a specific "public consciousness – fascism", focused only on tough violence, had a vivid fanatical character, **EXCLUDING ANY COMPROMISE** with an "elementary natural reason", and relied on an indefinite, **ARTIFICIALLY CREATED RITUAL MADNESS** and fake sacredness. Fascism, as a separate component of the overall control technology of the System, **"stimulated"** the control process going both within the effective influence of the "programmed ideology of liberalism" on the formation of its public consciousness, and within the practical "ideology of communism" through its specific influence. With all this, **CONDITIONS WERE CREATED FOR IMPOSSIBILITY** of their tolerant contact or mutual merging.

The necessity of the mandatory psychological presence of the ideology of fascism as the technology of energy-informational support in the general control program of people's executing actions may be accounted for the need for borderline functional separation in the formation of a strictly identified separated social consciousness responsible for the specific orientation of the civilization type program development. The very demarcation of development vectors into capitalist and communist types is an indispensable condition for the entire chronoprocess, which ensures the completeness and harmony of the programs for energy biogenesis and the development of Brain genotypes in a short time, as anticipation of the transition to a new stage of civilization development – the "Golden Era".

One vector positioned and focused the public consciousness formation on the development and establishment of all forms of organized being through financial violence with its future imposing upon the lifestyle of the entire world community. ***This type of civilization is "capitalism"*** as the process of development of the perfect functions of the Brain by **a LIMITED GROUP OF GENOTYPES** to control the actions of the whole society through complex forms of violence.

The other vector is "***communism***" ***type of civilization***, had a more extensive direction. On the one hand, it was an anticipation of preparing for the future functional-territorial endowing of Russia for its transition to the next program stage after 2012. For this reason, it positioned and directed the current gradual social mass consciousness to the early creation of industrial-productive capacities as the necessary amount of the generated capital for the future and, simultaneously, brings the territory of the USSR ***to the level of available access to the future use of natural resources by a limited group of individuals***. Without the collective principle of organization and nearly free use of labor, it would have been impossible to accomplish everything specified for this particular territory in a short time. The build-up of high rates and huge amounts of created values, necessary and accumulated for future stages of development as part of a limited group of individuals, had to be kept as much as possible ***by means of an illusory and limited distribution*** through underprivileged and conditional "social justice" among those who created and accumulated all this.

Without "stimulating" administrative-force violence, "invested" in a specific control structure, both types of civilization **COULD NOT HAVE BEEN IMPLEMENTED** as a controlled programmed executing process with people's use like consumer goods;

- the need to test the functions of the Brain for two isolated variants of the organized being control structures with capitalist and communist elements of the control through violence in the interests of the future expedient control structure at the new stage of civilization's development, divided into the levels – the "Golden Million" and the "service" layer, ensuring its existence, under the control of the future Brain genotype **46**;

- the necessity of imposing on individuals of Brain genotypes **42 and 44** of special **CONSTRUCTIVE MANDATORY FUNCTIONS OF PARASITISM**, which unconditionally distinguish the sense of their

existence in all general and individual processes of the programmed executive actions. This obligation ensured the unconditional introduction of such programmed structures of the organized being, ensured the exactly required strict hierarchy of power states and control structures. Imparting such sufficient controllability to all executive processes **THROUGH THE ACTIONS OF PEOPLE** in each separate society based on a specific public consciousness in order to implement and keep the corresponding type of civilization in a specific clock period of the current historic chronoprocess. ***Parasitism can only be implemented through violence***, thus it was one of the conditions for their existence in general and the corresponding existence of individuals of Brain genotypes **42 and 44** under the old System control;

- a recurrent programmed need for a liquidation sweep from geographically concentrated groups of people of other Brain genotypes, the essential need of the clan continuation which according to the program of energy biogenesis was completely discontinued according to the plans of the System.

Since December 26, 1990, the old System imparted this program control process a completely different, no longer "stimulating", but ***an independent function – as a control process of global independent nature***. This control process has gained a predominant level regarding liberalism and communism in the programmed executive actions with people's use like consumer goods. Having started as a more advanced control technology while implementing the final phase of the current stage of civilization development and ensuring the level of controllability of people's actions prepared for the transition to a new phase, "fascism" gained clear-cut directions of its effective governing application: ***structuring, financial and national-liquidation***.

The structuring direction is the imposing of the programmed actions related to the fundamental changes in the very structures of the organized life of people, their being and the elements of the tough society's control at an accelerated pace and uncompromising action. Due to the introduction to individuals **42 and 44** of the Brain genotypes of another information control support (new program) from the System, the "personnel" corrections in all significant and crucial elements of the societies' control were completed. A very significant role was played by the functional distinction between genotypes, which made it possible to separate the nature of their executing actions, namely: representatives of genotypes

441 were focused by the program on the destruction of the old control structures and the corresponding residual organizational fragments from previous types of civilizations. And representatives of genotypes **442** were oriented in their executing actions towards the introduction of "recommended plagiarism" – Western liberal construction of the organized being, based on financial violence, i.e. "market relations".



The financial direction is the introduction of another “value assessment methodology” in the Western framework in all areas of organized being, relied only on the social parasitism prevalence and the imposed financial violence in all forms of its possible manifestation. Due to the above, there was implemented such a construction of the society’s limited social organization in which the entrenched social parasitism acquired the level of the highest brutal efficiency, ensuring ***the complete suppression of people’s will.***

National-liquidation direction – destruction of the earlier-existed public consciousness, elimination of the communist worldview basic foundations, ***complete suppression of people’s will***, bringing people to an unreasonable humility in the executive processes and behavioral actions. Full alienation and introduction of mutual hatred in the environment of the former harmonious socionic picture of relations between indigenous peoples.

As a result of all the events in the sphere of the executing processes, **by the beginning of 2000**, there had been three distinctive directions of the "fascism" control program as a real modern technology of the executive actions control having the final goal of their completion, namely, to be the threshold of the transition to the completely new control program of the old System – **"the Golden Era"**. Such independent directions were: **administrative-bureaucratic fascism, financial fascism, national demographic fascism**. People are facing all this in full today trying to understand what is happening and find at least some explanation to this.

Each separately expressed direction of the "fascism" control program and its corresponding acquired executive states provided the existence of the invisible three additional facets of the control in the very **Construction of the Political System of Russia**. So to those three public and legal (through the Constitution of the Russian Federation), the facets of power, namely, Legislative, Executive and Judicial, added regardless of the will and desire of society, three more invisible facets: **Administrative bureaucratic fascism, Financial fascism and National Demographic Fascism**.

So in what way this task is being solved today and what is going on? Due to the destruction of the Old Program and the introduction by the New Program at the conceptual level of the main foundation through the world outlook "I" and "We", i. e. liberalism and communism, are completely reoriented in functions and goals, and mandatory and practically are imposed on the organizational control strategy – **"Leader"**. The simultaneous application of them at all three levels for the implementation of such a strategy, namely: **Leader-personality; Leader-people; Leader-Russia**, for the first time, will impart them both target and functional combined harmony instead of a contradictory relationship to one another in the old times of their use. Such a strategy (Leader) will contribute to the correct filling of the new organized being of the new construction. This process has begun, but in our everyday understanding of the world it is very slow. "I want everything at once and tomorrow" – will not work here. Regarding the conception of "social parasitism", which triggered up the earlier manifestation of Inferno-fascism in its three forms, namely, administrative-bureaucratic, financial and national-demographic, – is completely subject to liquidation, and basically, through the new Construction of the organized being, which is happening today before our

eyes and that is vividly expressed for those who have already learned to think and analyze the information received, though, in many ways contradictory one. The main and key issue here is, from the point of view of psychology, or rather, strategic psychology, which is also being revived – "**HAVE LEARNED TO THINK AND ANALYZE...**" So let's continue.

There was no strategic psychology. The scientific and political debate about the future of Russia suddenly ceased in 1991. After 1991, when the politics had to acquire scientific features, the tactics of the rally policy got distorted into the practice ***of radical anti-politics with a large share of criminal actions***. There are many who remember this period well. The scientists' arguments in this direction, including A. I. Yuriev, respected by me, are absolutely correct from the point of view of everyday life perception. But they, in my opinion, are only within the framework of the science and those concepts that were imposed from the outside within the framework of the implementation of specific programs of that control system, which at that time still went on operating. However, these developments and arguments are very useful in our current perception of the ongoing events, since they can and should become a reference point in your reasoning. And if the so-called "rulers" listened at least to such minds as A. I. Yuryev, then, perhaps, with respect to the life of the "ordinary people" everything would have happened a little differently. And I want to note that the foundation, built on the knowledge that can be gained from A. I. Yuryev, will help the readers to have a deeper look and analyze everything that is happening before our eyes, if they can not find answers why this is happening this way, and not another one.

The term "***anti-activity***" as a general scientific and practical category was introduced by O. V. Sukhodolsky, the professor at St. Petersburg University. This concept explains the phenomenon of "antipolitics", took place in critical periods of public life in France, the United States, Russia and other countries. This phenomenon is the cause of unprecedented historical metamorphosis of Russia: the disintegration of the USSR, the split of society, the events of 1991 and 1993, nearly complete stop of production and the criminalization of the entire economy of 1998.

In France and the United States the problem of antipolitics of the 60-70-ies. was successfully overcome and they emerged from the political crisis successfully. I hope you understand now why they "have overcome and safely emerged". ***A radical antipolitics*** with criminal support is characterized by the thesis "***No man – no problem***". In accordance with this thesis, a

specific man is considered a source of political crisis, and therefore the crisis is resolved by force – the man is either annihilated or suppressed. However, despite the repression of millions of people in the USSR, all the traditional problems of Russia in 1985 jumped out like a genie from the bottle – in a complete set (low labor productivity, poor product quality, poor management, lawlessness...). The mistake of radical anti-politics lies in misunderstanding that the **PROBLEM IS ALWAYS OUTSIDE OF MAN** and is independent of him, it is senseless because of the inability to solve the problems of the society's life support and the intension to destroy the consequences of unsolved problems and not the causes. In contrast, **science policy** proceeds from the fact that the sources of political crises are not specific, supposedly guilty people, **but problems of their life-support deficit**. I draw your attention – this is a very important conclusion, which confirms what is happening before our eyes today. Science policy overcomes crises, solving the problems of life-support resources by methods of science. There is a problem of energy resources – and the policy is activating the development of new types of energy carriers, efficient engines, etc. There is a problem of food – and the policy is reforming power in such a way that effective systems are created for the production, processing, storage of food, etc. It should have been so; however, precisely today it is different. But I see the events somewhat differently, believing that not-solution of these issues both within the framework of science and politics- is the **INDICATOR OF THE UNNECESSITY AND INABILITY** of such a policy and science. We need a new science and a new policy. The very fact of the humanity's existence and its undoubted success is ensured, from this point of view, primarily **by the non-use of force, the use of the human Mind, the discoveries of scientists, the progress of world science and university science in particular**. Since 1994, the face of anti-politics in Russia, has been determined by the political "intelligence", "counterintelligence" of internal groups, clans, and a new division of one people into friends and foes. The antipolitics gave rise to the practice of solving controversial issues with the **PHYSICAL SUPPRESSION OF OPPONENTS**: threats, beatings, assassinations, and murders have become commonplace in Russia. Antipolitics brought down an avalanche of anti-information on society: falsified, disorienting, demoralizing, destabilizing, misinforming, disorganizing, defamatory, disintegrating. As the devil pretends to be God, so anti-politics pretended to be politics. It is hardly surprising that the overwhelming majority of people consider politics to be a dirty business! The attitude of a serious scientific intelligentsia and the

majority of people to antipolitics and in general to real Russian “public” life is contemptuous. However, despite a similar attitude towards politics, by 1994 it had become clear that more than half of all psychologists, political scientists, and sociologists with a university education are involved in providing political activity in the composition of a wide variety of parties, movements, administrative structures, and leaders in general constitute the bulk of official advisors and consultants to the active politicians. In business or political dialogues, with some psychologists’ starting the ball rolling, ***neither the point of the subject, nor the logic and clarity of thinking, but the technique of emotional, perceptual⁵⁴, volitional suppression of the partner has become important.*** The cleverest tricks in the field of law, finance, economic relations, and combat operations give out the participation in them of people with university knowledge of psychology. For example, in the summer of 1997, I had to meet with a group of specialists who ensured the election campaign in one of the largest cities in Russia, who were very seriously interested in the psychological support of political provocations, sabotage, blackmail, etc. Such was the attitude of modern scientists to politics. It has little changed today. Shall we leave everything as it is? And if to change, then what should be changed? But this can only be changed within the framework of those new transformation processes that are more and more manifesting themselves.

One of the important elements of the Civilizing picture of Russia is its state party constructive arrangement today. ***On the one hand***, this is the construction of controlled organized people’s being – the Cluster of State Control. The Control was exercised from the outside by the interventionist Control System as an internal control with the help of organized “instruments of state violence”, which was based on:

- programmed current Target Vector of future events, actions and phenomena, corresponding to the time of historical chronoprocess;
- the imposed goals of each stage of people's executing actions in the implementation of two strategic programs (Development of the Brain genotypes and Development of the energy biogenesis of the flesh cell);

⁵⁴ Perceptual (lat. Percipere – perceive). Related to perception, that is, the process of reflecting events, objects, phenomena ... Within the framework of psychology as a science, the term “perceptual” is most often used to define sensory-perceptual processes – those that provide the connection between the internal and external world through the work of the senses.

- strictly expressed Construction of the social development control hierarchy according to the degree of relative "controllability and significance" of all people taking into account the specifically expressed Brain genotype of each, as a general (state) model of people's executing actions which they illusorily imagined as if the society for "living in common" to meet the emerging social, spiritual and other everyday needs and other less significant things.

On the other hand, the parties those seem to have some undoubted significance at the "state level" in solving some of their problems. What is our point of view (of the parties) on the basis of the methodology of the energy-informational dialectics of the Brain genotypes development, corresponding to the current stage of materialistic idealism? ***The authorities today is the power of the impostors of various parties, who with special fury of "the unlimited egoism" tear it to shares of their participation in this very power and thereby organize for themselves a guaranteed parasitic way of life.***



It is also expedient to note that, despite the constantly changing tribune range of parties, with their overall quantitative composition they have never been able to cross the barrier to 1% of the total adult population of the country for the last 20 years. In fact, modern "parties" are a local assembly of **SOME INSIGNIFICANT GROUP OF INDIVIDUALS**, "officially" registered and received the status of a legitimate (i. e., "legitimately" recognized by the same controlling minority) small-scale

element of a social formation. They are genetically not able to express the interests of the overwhelming majority, even if they suddenly wanted to direct all their vital and creative attention to this. There are many people in Russia today who already understand this. The formation of the current parties, irrespective of their number, is realized mainly by the local unification of individuals of the past **4XX** Brain genotypes, with the obligatory consideration of the past "technical" connection through their specific "Control Server" with reference to those "individuals" (it is hard to call them people), which are still functioning limitedly, and also with the obligatory observance of the past "links of subordination" to the governing and executing hierarchy, which was previously detailed through the mantissas of **EACH SUB GENOTYPE OF THE BRAIN**. This is unconscious of them and is happening just in auto-motor-like way, not according to their will, but as some kind of forced step of their present way of life, deprived of the former support and control from the outside! Artificially imposed "slogans" directing them, as if, to "vigorous activity" (as programmed information of the controlling nature in a simplified speculative form), and all non-systems "executing vanity" are imagined and perceived by them as *their active life position*, having a certain undoubted significance at the "state level of solving any problems", **BUT IN FACT BEING USELESS NOWADAYS**, especially for the future. Some important peculiarity of the changes that are taking place during this period should be emphasized: the more they lose their effectiveness from the "power of their rule", the more state violence in their favor they will organize through the seized legislative, executive and judicial power. There takes place a completely different orientation in preparing and executing actions and events. All previous goals, techniques and methods of action and their control are already becoming atavism. The preservation of part of the control of energy information support for them is connected with ensuring their biological existence and supporting the actions associated with the old Construction destruction of the being organized by them, no matter how absurd it would seem to the reader. These are the realities of today. There may be only one advice here, in my opinion – in everything that happens, try to find something positive, no matter how negative this event may seem to you.

The simplification of the individuals Brain genotypes **4xx** functions, in terms of their influence in the scale of the entire society, and the usefulness of their actions and existence within the framework of the ongoing processes

of change, occurred as a result of the fundamental change in the very essence of the energy information translation on the side of the recreating new Control System to support the people's executing actions in general. This is a systemic process, and it takes place independently of people's will and consciousness. This simplification has occurred recently, since the **"Final change of the System power" (since 2011.04.24)**. This "simplification" is growing. The information restriction of the governing nature brought to the corresponding subsequent limitation of the "public consciousness" states, a significant change in the formation of "needs" as the basis for subsequent practical actions, focused mainly on a sharp increase in irrepressible aggression, growing of insane vicious passions, including unlimited wealth by means of violence, destroying everything in any sphere of being, which contacts with them, simplifying the elements of residual unstable worldview (including organization of plots of various scale, repartition of the world and so on.), limited opportunities to find solutions, and many other things that were not previously typical for such individuals. All this accounts for the majority of people's misunderstanding (mildly speaking) of all those "insanely absurd" decisions and attempts to legalize these decisions in the adopted laws – the laws that are adopted by the same ones – with simplified functions. Moreover, all new information of the governing nature, translated by the re-created true Control Complexes, is **RECEIVED BY THEM IN A LIMITED FORMAT** (for "technical reasons"), mainly oriented on the unconditional execution of the so-called "Album Records", only within the framework of actions related to ***the destruction of the previously created old Construction of the organized being.***

It is this state, as one of the important elements of the Civilization picture of Russia in such a specific present day party-political structure, that still holds in a stable state all the basis of parasitism and violence in our country as the foundation of the civilized development of the "liberal-democratic" type which, in turn, in line with the old programs, would have inevitably brought to the country's participation in the creation and arrangement of ***the "Caste World Order of the new slave ownership"*** with the entire "globalized "Elite, including the elite of the present rulers of Russia as the executors. Today they practically go on participating in a fading, but still dangerous, global conspiracy. They do not care for the consequences and the future of the country and its people, since to fawn on the world elite is paramount for them. But this **WILL NEVER**

BECOME IN THE FUTURE, AND IT SHOULD BE REALIZED by the whole depth of the ongoing progress towards the truth! This is the whole causality of the creation, arrangement and understanding of exactly such Construction of the state-party condition, in which we are today and are trying to understand why everything is happening exactly this way.

4.7. Predetermine, but not let...

In the crucial years of **1989–1999** on Staraya Square in Moscow, in the state dachas near Moscow there worked a lot of "brainstorming groups", and the like. I also had to take part in this, and, as it seemed then, quite successfully. At least, I then had a desire to create a kind of "instrument" of uniting people, which would make it possible to solve issues of their concern, not within the framework of the Duma or other state bodies, but within the framework of a public consultative form. This is what I realized within the framework of Leningrad Region, by creating "Public Chamber". And after a while this experience helped to create Public Chamber under the President of the Russian Federation⁵⁵, which, however, existed for only two years and was reorganized into something incomprehensible, but in Leningrad Region it still works. On its basis, in 2005, Public Chamber of the Russian Federation was "revived", but not in the form in which it was originally conceived.



⁵⁵ President's Order No. 78-rp dated February 16, 1994.

Also, at the end of 1996, I suggested “enlarging” the representative offices of the President of the Russian Federation and creating certain territorial divisions in Russia, sharply reducing the number of Representatives of the President of the Russian Federation. The experiment began its development in 1997 on the territory of the North-West, including 16 representatives. After a year of successful work, a document was prepared to transform all representatives offices into 13 territorial divisions in Russia, based on many factors both of regional and federal structure. The documents were handed over to the leadership of the Presidential Administration, approved and were to be applied in 2000, with the election of a new President of the Russian Federation. But in 2000, after the elections, for some reasons (at that time I did not find a justification), out of 13 there were "made" 7 regions. And only after more than 15 years, having already learned the works of N. Levashov and A. Khatybov, and taking into account the materials of the ***"Foundations of Humanity Formation"*** as well as our talks with B. Makov, I realized why it was done that way and not according to the proposed one. But most importantly, I understood – upon whom it was imposed for execution and what for. I was right in my reasoning and the materials that I present in this book – are the confirmations of all this.

Most often at that time, and, practically, since 2000, in the positions on which decision-making depended, not professionals and scientists dominated, but at best, graduates of higher educational institutions of that time and the people (sometimes experienced in the past), who had gone through the school of management in the departments of the CPSU. Specific, practical, decisive professionals in modern management actions – “brainstorming” – behaved as if it was happening at an industrial enterprise where an accident occurred. This was not a novelty: it was exactly the way the long-houred emergencies occurred in the factories, but, unfortunately, the sleepless nights and heart attacks in the workshops were senseless. The final phase of the current 4th stage of development of **442** Brain genotype was in progress. The whole process of the control the system measured **ONLY THROUGH THE PECULIARITIES OF THE BRAIN FUNCTIONAL CAPABILITIES**, dividing the entire structure of execution and executors only through the prism of the Brain genotypes. And only on this basis all controlled executing processes were built. In addition to the programmed changes in the control process itself, there were undertaken qualitative and quantitative changes in both the controlling and controlled classes. Each class has acquired by this time its state of "need,

labor and work". In the controlling class, **"energetic leaders-grabbers" came** to replace the rulers with the ancient roots of all the former representatives of the clan "type", before whom there were no obstacles in the execution of the commissioned.

Due to the significant intensity of the information flow, both in the control information and the information of cognition, an individual approach, even with the experience of the past (taken from the CPSU), was categorically insufficient. It was possible for realization only collective "work of people", controlled from the outside through the emerging leaders. For both the controlling and the controlled classes, an individual character was retained only for the implementation of decisions already made for them. Therefore, **there appeared "true leaders"** for whom there were no such tasks, **WHICH WERE NOT FEASIBLE FOR THEM**. This is a programmed process already involving the individuals of Brain genotype **423** with their specific capabilities. It was with the use of managers of such an executive state that the processes of programmed control were carried out with incredible speed and without delays.

Start your quest (this is for the young) and memories from March 1985 – with M. Gorbachev's start in power, the end of the "lush funerals" era and all the processes that were directly connected with this "leader". Then B. N. Yeltsin, the collapse of the USSR, the leaders of the newly formed "independent" states from the republics of the USSR, and so on. Combine all these fragments, and then the picture for you, readers, will become clear. All the eyewitnesses of what was happening in 1991 perfectly remember this nightmare period of the collapse beginning, one's complete confusion and the state of inexplicable non-resistance to everything done that time. The USSR, without a single shot, "surrendered" with its anthem, flag, oath, opened borders and fell apart. The rockets could not take off, because by 1970 there had not been any psychology-political force in the country, capable of "raising a giant sword" forged by the overstrained might of the people. And "all hands on deck" method in management with all its attributes was transferred by professionals from the collapsed production to social activities that "fell out of time" and for reasons of intellectual helplessness lagged behind globalization, changing everything and everyone on the territory of Russia. Under these conditions, created not through the fault of people, there really existed so-called civilized **"ideological confrontation"**, such as, for example, construction of "capitalism-communism" and so on. Was there a real confrontation, or was it an

organized information-controlling illusion from outside, which, this way, through some kind of "ideological opposition", directed the step-by-step development process of Civilization "Parasitism and violence"? I remember how sincerely and openly some people made desperate attempts to dispel the ideology of the opposite side, bringing out ideological advantage of their side to the level of "unsurpassed perfection"! Try to remember the Congresses of People's Deputies and all sorts of other meetings and rallies. And all this took place as in the distant past "unreal dream", but after all it was all in the real life embodiment! And where did it all go?! Cleared like the morning mist, and then quickly fraternized, united in the evils, violence and parasitism, and together keeping step all went to win and destroy everything with redoubled effort. How in an instant the ideological sense of all the same songs changed, which had previously demonstrated the loyalty to the communist ideology: "...To the very ground, and then..., The squad did not notice the loss of a compatriot... and so on! Is there no more ideological battlefield? No, there isn't, indeed, **IT DOES NOT EXIST ANY LONGER**, since not only the confrontation of ideas disappeared, but the former civilization ideas themselves ceased to exist altogether as the basis of the entire previous world view and its influence on the whole process of a divided being. In one unprincipled executing reckless thought, **BEING DICTATED "FROM OUTSIDE" BY THE RESIDUAL PROGRAMMED ASPIRATION OF PARASITISM** and violence there have got together "international groups of executors", mostly from among individuals of Brain genotype **42-46**, who **UNITED AROUND SOME INSIGNIFICANT MINORITY**. This is the process of emergence from nothing of all those who consider themselves the "ruling elite", their permissiveness and their own enrichment (on theft), and what they have done and go on doing in auto-motor-like way. Such a connection was accomplished not by their will (I do not justify them, but I state what is happening) and not only with the high hopes for profit in the midst of "market battles" and unlimited egoism, but by the will of the Control System programmed commands. The programmed recklessness of such a thought *is Globalized financial, administrative-bureaucratic and national-demographic pervasive planetary fascism!* But this is no longer a "civilizational idea", it is **NON-ALTERNATIVE RESIDUAL INFORMATION OF THE CONTROLLING CHARACTER** of the old *System* as a past order to perform *unconscious actions of a straightforward nature*. For the implementation of this "lawlessness", the field for civilizational ideological battle was no longer required.

Today, the current pseudo-leaders of the already destroyed Anglo-American-European civilizational lifestyle, cornered into the elimination of the entire past Construction of violence in all spheres of our existence, have passed **INTO A STATE OF SHRIEKING HYSTERIA in the sphere of the artificially created fifth war space, i.e. Cyber Space**, intimidating and eclipsing the Consciousness and the Mind of people with dirty lies in everything through the mass media, using digital technologies and, of course, the Internet all over the world. Past large-scale wars with traditional means of annihilating everything and everyone went into this very past, albeit retaining elements of intimidation by "saber-rattling", including nuclear one.

The "unbending liberalism" of the Western type, having spread its roots in Russia only to the level of **destruction of the previously created common values, has decayed**, and along with it the historical programmed Cosmopolitanism⁵⁶, as **a 600-year program**, was far from being fully implemented. It was stopped by the elimination of the previous controlling programmed directives along with the old program, and the removal of the former Executors from the Conceptual power. Globalization, as the final stage of Cosmopolitanism, also failed to cover all Russia's natural raw materials with its empty monetary power press, completely destroy the basic part of the economy and complete the seizure of the remaining values of the country for themselves. Don't make hasty conclusions based on the fact that all this has not yet finished and continues to occur before your eyes. To make it clear, we have to think about the fact that the society as a whole and the **CONTROL OF ALL THE PROCESSES** of its social development is not a natural essence and not our aspirations, mainly based on the emotional perception of the happening, but quite specific and **STRICTLY CONTROLLED FROM OUTSIDE PROGRAMMED PROCESS**, especially in today's time. The process that controls the Brains of people writhed by the Old System, many of whom are just inadequate, because all the versatility of the former control, covering all spheres of human activity, combined with the energy-information translation of the cognitive and controlling nature from the Control Complex (the Caucasus, the Alps and

⁵⁶ Cosmopolitanism (from the Greek. Kosmopolitus – a citizen of the world) – ideology, the so-called. World citizenship, denying state and national sovereignty; a system of attitudes based on the refusal to recognize the priority of national traditions and culture over the traditions and culture of other countries and peoples, proceeding from the common interests and values of all humanity, relating various manifestations of patriotism to primitive forms of human consciousness, etc.

California) – all this was perceived by them (i.e., by people) as a "natural" process of the civilization development. And suddenly the perception of people began changing sharply. I just want to point out that quite a lot of those who got a false idea of themselves were left without "perception" at all, needless to say about public consciousness.

Let us return to the fact how there turned out the programmed "scenario" of the performance of each episode of the past events (that is, history in people's understanding), but, in fact, the technology of system control from outside. At first the interventionist System **FORMED A SPECIFIC STABLE STATE** of individual consciousness for a certain future "historical programmed event episode" and the level of general cognition of the corresponding time period in the individuals prepared with the state of their Brain (from Brain genotypes 42-46). In future, the Control System through the Control Complexes of the Caucasus, the Alps or California carried out energy-information support, but with the information of the controlling nature for the time, which made it possible to form in people a steady state in the necessity for actions leading to the planned events. Such governing was irreversible; it was controlled by its results as the cluster control system of the open type. Before every upcoming programmed "historical" actions and events, the flow intensity of the information impact and support on the Brain of people involved in such participation was necessarily regulated. This made it possible to lay the executing states and processes into an expedient logical temporal system both in the formed public consciousness structure and in the structure of the constructive necessary social development of society with the required number of the involved performers and the territorial coverage. This is the way people understood this programmed "scenario" of each episode of history and its control. I am writing about it with so many details so that the readers could understand the complexity of "lining up" of these processes, could have an idea that something similar is happening now. The very scheme of the system of controlling people's being today has undergone little change, because "drastic" changes would lead to tragedy of enormous proportions. But information, information support and an impact on people's Brain is completely different, with entirely new possibilities and vectors of realized targets by the Native Control System. But it is obvious the difficulty in the Brain accepting of all the new. I do not mean those people born after 2012. These people (children) have entirely different Brain capabilities. I mean today's main mass of people. Helping them is objective and expedient,

without exception, regardless of the Brain genotype. Such was the position of N. Levashov, and this is my present position. ***If man understands and asks for help – you should help and support him.*** And then – not for you to decide.

4.8. To comprehend the prospect

Impersonality, with no one's own say, mental laziness and, as a result, mental weakness are the diseases that our society suffers as a result of what had been done with the Human Brain. Today, all this not only hinders the human mind development, it makes strong people suffer and choke in the atmosphere of routine concepts, ready-made phrases and unconscious actions. Least of all, "people behind the scenes" need thinking people who are capable of critical reasoning. That is why they have created, and still are trying to make up various illusions – this illusory spirit of the time. They do this through religion, through the mass media, through education, so that we would live inside the bubble of our illusions. And they almost succeeded. But human nature, which no matter how hard they tried to bring it low to the state of "obedient animals", is so rich, strong and elastic that it is able to maintain its stability, freshness and beauty in the midst of the most oppressive ugliness of the environment. But it needs feeding, and feeding is education. And this, in my opinion, is a key subject today. Without education, there can be no correct information perception and assessment of the ongoing. Without education, there can be no cognition. Today the line between education and brainwashing is very thin. Many people can fill in the "Education" column with the word "Television" or, at best, the "Internet" with its social networks. Education is very important, but formal education is, in fact, not necessary. Much more important is to accumulate knowledge and experience and gain the right worldview. We perfectly see what is happening to education today. Instead of mathematics – a whole day of physical education. Personalities disappear among people leveled by education. This is an axiom. However, he who values the life of thought, he knows very well that real education is only self-education and it begins at that very moment when man, having said goodbye forever to all schools, becomes a full master of his time and his activities, especially these days, as A. Khatybov noticed, – when everything we learned, turned out to be a game of blocks and horse knowledge.

In our so-called socially mass development, we have come to the conclusion that any professional higher educational institution predetermines a profession, but **IT DOES NOT MEAN THAT IT PROVIDES EDUCATION**. Special education institutions provide ***the means to achieve goals*** set by universities. The scientific nature, unintelligibility, difficulties in creating these means does not give up to the scientific nature and complexity of the search for the university purposefulness.



A ***technical college*** provides a specialty, but does not necessarily predetermine a profession and does not provide education. These educational institutions offer the opportunity to professionally apply the results achieved in universities and special higher and secondary educational institutions, and you can believe everything that they present, but the knowledge that should be transformed into cognition cannot be built on this, and convincing evidence given as examples from science is built because of the lack of any other knowledge systems. It, this other system of knowledge, is only being created. This is another reason for what is happening now. Look here: politics is the most strictly ***calculated construction of power***, which relies on the system of knowledge from literature to mathematics. But there is no system, and more so, knowledge. Therefore, there happens what happens – no more and no less.

The interventionist System laid only limited and only consumer goods-like use of people, expressed in everything, including education, as the basis of the principles and goals of the control for all human development, including their education. The old System had no other strategic and goal orientation regarding the development of people! The determining condition for this essence of education and the essence of life is the violent impact on people by the System's control information. All social relations, including those in educational processes, were built only between the ruling and being ruled classes as a single executing process of the programmed implementations at each separate stage of civilization development, controlled by the old System.

There is a lot of studies on the state of the point where humanity is today. Such studies theoretically calculate the point of a new, more perfect state of society. But these are only theoretical assumptions that for some reason are not realized today. All these studies, carefully conducted and presented in futurological forecasts both to politicians and general public (but only partially), are secondary in relation to the main resource, including politics,- the human resource, for the sake of which they are obtained, bought, and fought. Therefore, our so-called national leaders received knowledge in the field of social processes not systematically, randomly and from dubious sources. If you look at the whole picture, then, for example, Russian universities have never given a systematic education in the field of scientific politics. But it was also quite a natural process of the executing state. But from the point of view of entirely subjective understanding, then a sign of the lack purposefulness in Russian public life was and is, for example, the concealment of the historical political speeches of their leaders, which could have become the subject of national pride, such as William Churchill "Two Wartime Speeches", FD Roosevelt State-of-the-Union Address, E. M. Kennedy "Truth and Tolerance in America" and others meticulously studied at universities abroad. Of course, we didn't pay attention to the fact that all "politically successful" (depending on the way you look at it) countries publish collections of speeches of their leaders, and each new political leader **IS THE SUCCESSOR OF HIS PREDECESSORS**. In Russia, *each new leader wipes out the texts of the speeches of his predecessor* with the confidence that his successor will do the same with the texts of his speeches. Shall we have to look for some other evidence of these people's lack of a long-term geopolitical concept, continuity of policy and goal setting for a deep historical perspective? But this is also secondary in today's understanding of what is happening. However, for the future it must still be borne in mind. As soon as leaders begin to specialize, professionalize, and serve private goals, the main goal of their activity disappears. All this is happening before our eyes. But the conclusion that it is precisely for this reason there is no goal setting for modern Russia and there is no geopolitical concept is fundamentally wrong, especially for those who at least have read the material presented. Let me give you one example, referring to the history of Petersburg University, which, within the framework of all the same philosophical and scientific reflections, was supposed to fulfill the **MISSION OF GOAL SETTING FOR HUMANITY** through the discoveries implemented then in the means of our civilization (V. I. Vernadsky in the noosphere teaching, D. I. Mendeleev in Chemistry,

P. L. Chebyshev in Mathematics, I. A. Baudouin de Courtenay in Linguistics, N. O. Lossky in Philosophy, V. V. Platonov in History, A. A. Block in Literature, A. S. Popov in communication technology, P. P. Semenov-Tien-Shansky in geography – the list is long). The recognition of this is the seven Nobel Prize laureates from St. Petersburg State University: I. P. Pavlov (1904), I. I. Mechnikov (1908), N. N. Semenov (1956), L. D. Landau (1962), A. M. Prokhorov (1964), V. V. Leontiev (1973), L. V. Kantorovich (1975). Graduates of St. Petersburg State University anticipated the future when they were outside Russia: economist V. V. Leontyev, physicist I. Prigozhine and others. Few people remember that Norbert Wiener, the founder of cybernetics, studied at St. Petersburg University, and it was here that he found ambitious ideas that changed development of technology and our lives. Petersburg University gave the world such outstanding political figures as P. A. Kropotkin, P. A. Stolypin, A. F. Kerensky, P. B. Struve, V. I. Lenin, etc. However, due to many circumstances, which the reader already knows, **THEIR CONCEPTS OF THE FUTURE TURNED OUT UNREALIZED**. Petersburg University *"was not allowed" to form a social science school.*



A new real national civilizational idea, giving a bright appeal to the true future movement, has already been **Manifested**, that is, it already exists! No matter how much it might seem high-flown, but this is the idea to build a new society – Mankind! And this fact has to be reckoned without fail, the ongoing changes in the environment lead to this, whether we see and feel it or not is not important. It all depends on us. The road to this future is the preventive strategies. "The Preventive Strategies" have already been

developed and "coordinated", but not with the Lord God, but with the System, both in their true nature for expedient executing actions of people, and in accordance with the clock period of the event-driven time in their implementation. This becomes clear if one begins to read and comprehend "***The Fundamentals of Mankind Formation***" in the most careful way, at least that part which is available today. And then it becomes clear that ***the Actions***, as the next stage after ***the Manifestation***, are a verified mandatory Program of preventive executing processes, as they are realized, ***the Event*** will be formed, that is, as a result, the transition to a different way of Civilization development will begin and, of course, through people. It is the Actions that are presented by the Preventive Strategies, and their goal is: to give "the start to the Beginning" of the process of formation of the **STRATEGIC BASIC FUNDAMENTALS** of the new organized people's being Construction to ensure the transition of society to a different way of development. The monograph "***Fundamentals of Mankind Formation***" is **ONLY THE BEGINNING OF THE THEORETICAL WAY** to form a new civilizational idea of transition to a different way of civilization development. It informs, substantiates and fundamentally establishes the unconditional nature of such a transition, demonstrates the true causality and the urgent need to implement in this event-driven time and at the Conceptual level, outlines the true contours of the goals and directions of future actions and events. Take a look around carefully, and you will find confirmation of this. People have to radically change the whole way of their being on the Earth, if they want to be in the future.

The main ideological sense of the whole life arrangement of people's society for the XXI century until the moment of their final recognition as Mankind by the more advanced Civilizations lies in the following basic ideological fundamental of the Target Vector of the future phenomena, actions and events: Mankind is the Construction of a social non-violent state of society, in which justice of the concerted life of people is settled on the basis of the gained **COGNITION OF THE TRUTH OF ANOTHER LEVEL** and striving for the perfect Mind. Mankind is an irreversible transition to the civilizational development of a reasonable orientation, plus abounding, accessible and value-free energy of non-raw material supply and non-destructive technological perfection. These are completely new, different technologies, aimed primarily at improving the life support system of man. To such technologies there can be attributed the technologies that came into being thanks to such Russian scientists as N. Levashov,

A. Khatybov, A. Luchin. Here, first of all, the “SvetL” Technologies are meant, as a kind of forerunner of technologies aimed at the Human Brain transformation and recovery. It is appropriate to note here that since 2013.12.26 it is precisely such a landmark episode that has found its beginning. This “Beginning” sets the entire primary basis for the formation of the fundamentally new picture of the reconstructed Russia and people living in this territory, of which they dreamed for more than one millennium, keeping in their soul the faith to Her and Her future! But this talk about executing actions, although the nearest, but still the future.

4.9. The society's identity

Today, in our worldly and everyday thinking, the threat to the country lies in the fact that by 2006, **the personified face of Russia** had begun to "fade". By this time, the country had experienced **three waves** of loss of its identity, if you look at it within the framework of the known historical processes. In **the first wave**, Russia lost most of its outstanding thinkers – creators of the world picture, perceived by people. After 1917, the outstanding individuals left the country: scientists (P. Sorokin and others), writers (I. Bunin and others), culture figures (S. Rachmaninov, etc.), designers (A. Sikorsky, etc.). I hope that with respect to "... and others," the readers themselves will find the names of these people, the taking as a starting point those I have given. **The second wave** by the end of the 70s. had taken the students of pre-revolutionary educational institutions who restored the intellectual power of the state after the October Revolution. Great workers, bearers of the firm life position: aircraft designers (A. Tupolev and others), creators of space rockets (S. Korolev, etc.), writers (K. Paustovsky, etc.), scientists (B. G. Ananyev and others). It was they who revived the national school of education and upbringing; they formed new features of the USSR, which won over the whole world to it. **The third wave** after 2000 threatened to wash away the facial features of Russia, having formed by outstanding personalities, bearers of a high **civic spirit**. There has gone V. Shukshin, B. Okudzhava and many, many others. The sad list of losses is not just too long, it looks like a formidable warning to Russia. The present generation of Russia, deciding which lifestyle to choose, does not have a model to imitate before their eyes. There was an unprecedented situation in Russia when the academician D. Likhachev, a graduate of the Faculty of Social Sciences of St. Petersburg University in 1928, was known as nearly the

only intellectual. And, as a result, for example, the so-called “democratic” system of elections to the state bodies as the “instrument of democracy”, which since 1991 we all have considered to be the most important and unquestionable, revealed a catastrophic shortage of people who are known and trusted by the whole country. Today, the entire sphere of power, which, according to the provision of the imposed Constitution, should belong to the people, is actually without their will and desire seized by a small group of impostors. "Party linguists" to distract and cloud people's attention define the essence of a political party (Greek Πολιτική – "the art of governing the state") as a special social organization (association), directly setting the task of seizing political power in the state or take part in it through their representatives in government bodies and local self-government. And in this case the **OVERWHELMING AND UNDERPRIVILEGED MAJORITY** of the society has nothing to do with it. You were not and are not here, dear humiliated and underprivileged majority! If you are not a member of any party, then you no longer have any relation to power, especially to the election of any representative of your overwhelming majority to the authorities, because you are allowed to vote only for the names of the parties proposed to you without your consent and after that you are no longer needed! As they never expressed your interests and aspirations or any your problems of unjust social or any other worldly character, so they still do not express them, without paying any attention to that loud Constitutional postulate, trumpeting all over that all power in the state belongs only to you. Whether or not you delegate this authority to any self-styled gathering (numbering from 500 individuals and more), with the help of which, in fact, they live as parasites over you – it does not depend on you anymore! You are not allowed to discuss this now, since you are also deprived of the right to hold referendums. But with all this, respected, disadvantaged and humiliated majority, you should not worry about isolating you from the granted Constitutional right of absolute power, since the majority of parties (small groups of impostors) have a program – **EXPRESSING THE PARTY IDEOLOGY** (but not yours), a list of its goals and ways to achieve them (in defense of the interests of a personal nature for their gathering, withholding a sufficient state of violence and living as parasites over You by all possible legislative acts). A political party is a stable hierarchical political organization that unites on voluntary basis persons with common social, political-economic, national-cultural, religious and other interests and ideals, setting itself the goal of conquering political power or participating in it. ***Something like this, and without conquest, without fighting***

with you, they will not gain anything in power, but what is another way to live as parasites over you, and even without your consent to this? What the parties are like they are no longer hiding, both in the names and the sophisticated sense of their parasitic existence, but who they represent in the sense of putting a question of legitimate or non-legitimate representation regarding the constitutional right of the authorities on the side of the overwhelming majority of society. – this is, indeed, the question that people, and the whole of society, have to pay attention to at least during this Transition period. And to draw attention to the fact that the country's identity is formed from the "single" citizens, unique, inimitable – from individuals who are able to unite people around them. They are coming out, but they need new knowledge, and above all, an understanding of what is happening, which is impossible without orientation in today's strategic psychology. But strategic psychology, within the framework of the Old Programs, proceeded from the fact that the scientific technology of education and training has always relied on the psychological and pedagogical scientific schools created by people governed by the same programs leading to the realization of the final goal, which we already know. For example, associative psychology was created for upbringing "a helpful worker". Then the system of introducing into the long-term memory of **STEREOTYPE BEHAVIOR** using methods based on the principles of ***pleasure-suffering*** was developed. In the interests of science, industry, military training of that time, it was possible to achieve in the process of educating much precision of standard actions on similar elements combined in time and space. Another extensive direction in psychological science, which we have already mentioned⁵⁷ – ***behaviorism***⁵⁸ – was created for upbringing of the "right person", that is, a person with the imparted qualities. Behaviorists' discoveries made it possible to form human behavior algorithms based on causal relationships in the long-term active memory of a pupil, but the main task was to create specific 4XX genotypes within their sub genotypes.

⁵⁷ Book 2, Chapter 6 "On Mind, Consciousness and Matter, or "How to Dig with a Shovel of Knowledge".

¹³ Behaviorism (eng. Behavior – behavior) is a systematic approach to the study of behavior of people and other animals. It assumes that all behavior consists of reflexes, reactions to certain stimuli in the environment, as well as the consequences of an individual history, such as sustenance and punishment, together with the real motivational state of the individual and controlling stimuli.

¹⁴ Gestalt psychology (from germ. Gestalt – personality, image, form) – this is a general psychological direction, which is associated with attempts to explain, above all, perception, thinking and personality. Gestalt psychology puts forward the principle of integrity as the main explanatory principle.

No less ambitious branch of psychological science – ***Gestalt psychology***⁵⁹ – was also created with purely practical goals: the **FORMATION OF "A CLEVER PERSON"**. A certain method was developed for revealing the ability for insight, creative approach to the organization of behavior by restructuring the elements of the studied situation.

The needs of the twentieth century determined the creation of a new direction – engineering psychology, labor psychology and ergonomics. The task was absolutely practical – in order to avoid technospheric catastrophes of the man-equipment systems, because of human errors, it was necessary to bring up an ***"unmistakable human operator"***. All this was “done” within the framework of the program for creating the “golden billion”, and, in my opinion, quite successful.

The basis of theoretical models of the "human factor" was the ability to quickly, accurately perceive information, process it, make the right decisions and act in a timely manner.

Ya. A. Komensky, the founder of scientific pedagogy, introduced into the system of human upbringing systematized strict criteria and concepts of "wisdom, courage, moderateness and justice" as the goals of upbringing. As a means he considered the principles of "system, consistency, conscientiousness, collectivism, clarity, strength, exercise and repetition, use of visual aids." The outstanding Russian teacher K.D. Ushinsky introduced into pedagogy the ideas of “perfection, inner freedom, favorable disposition, rights”. ***Never has there ever been anywhere an unsystematic upbringing of human resources.*** But, as we already know, the goal of all the programmed processes exercised on Man and with his participation was to apply the unique perfection and capabilities of his so-called shirt, embed the Brain of interventionists (spiders) into a “shirt of a man” and create and preserve individuals of such Brain genotype in the amount of the "Golden Million". All existing and artificially created ethnic groups of people were to become only the consumable used up material, on which Program experiments were carried out to improve and bring the Brain to the programmed genotype in the right quantity.

All this was an act of violence over the very essence of the true purpose of Man on the Earth. People were weak before such Systems Control

domination. Man was driven into such a state **AGAINST HIS WILL AND WISH**, as a biological object according to the plans and programs of external control of alien Complexes and Systems. And, as I mentioned in the first book, I consider it appropriate to remind the reader here that control over the state of the so-called "biomass" was extraordinary important. The term "biomass" should be understood as the **BIGGER PART OF THE POPULATION OF PEOPLE**, which *was not subject to the programmed processes for the introduction of the Brain genotypes*, was used to a limited extent in the development processes of energy biogenesis, and to a greater extent was used as the so-called "*programmed-brain donors*", for the purpose of developing individual changes in the Brain functions and for making some examinations on the control of changes after the implementation and introduction of some changes in the habitat. No matter how sad it may be, but it is exactly the way it was. If the Brain of some individual from the entire controlled mass manifested itself by some indicators of functions as having received more advanced properties of reception, processing and indicative ability of the new Brain function, with other expedient executive operational qualities related to the manifestation of more perfect control over the operation of some separate internal organ, such an individual became a "programmed-brain donor". The improved peculiarity of his Brain in controlling the activities of some organ was taken by the control system as positive, that is, the best experience. Such manifested variants of the planned deviations from the previously tested control frequencies were recorded, and in the future, after repeated and mass testing on the programmed-brain donors, were duplicated for their subsequent installations on the "Golden Billion and Million". *Such processes sometimes took considerable time, and the testing was carried out on many generations of donors* without taking into account any emerging psychological people's factors. No psychology here was taken into account or applied. After the frequencies were established and tested in work, the whole mass of the previously involved "programmed-brain donors" was no longer needed, and the System got rid of them to prevent further development of such Brain functions in the mass of the former donors or generations born by them.

All actions were substantiated through specific executors as some historical "milestones" in the development of mankind, taking into account, of course, the entire set of psychological factors that justified the events occurring in connection with the destruction of "unnecessary" people

(biomass) through war, genocides and the like. The more complex the programmed Brain genotype was established in the process of its development from genotypes 42-46, the more "experimental" processes were required with multiple control testing of the Brain functions, both external and internal controls. This does not mean that such a development process took place by random sampling, i. e., "blindly." It was connected with an extremely complex programmed process of simultaneous combining the development of not only the functions and abilities of the Brain, but also with a complex program for the development of energy biogenesis of the individuals



themselves, developing incredibly complex and multivariate programmed processes in complex. The used up "material", as we already know, was removed by the System at the end. What came out of all this? I have mentioned and partially written about it, but, it is advisable to summarize everything for better understanding the realities of today: The human Brain corresponded and was needed by the entire harmony of the general level of the Mind development of the interventionist System as a whole, ***was the product of its program result in the broad aspect of the options for the program-target significance and application.*** Nothing unwanted and unserviceable in the executing consumable use was created. This "product" of the old System **WAS NOT SUPPOSED TO KNOW** what he exists for on the Earth, for what purposes and where his development is directed, all this was apophatic for him, i.e. beyond reach. ***The Brain was completely forcibly captured by the old Control System.***

The entire people's development control within the framework of the program for the Brain genotypes improving and energy biogenesis provided **COMPLETE INFORMATION TABOO ON THE TRUTH COMPREHENSION.** No matter what level of "native" wit people have at any stage of civilization's development, their Brain had always been the object of information violence on the side of the old System. And the entire development of psychological processes and psychology itself, was built through people only within these forcibly created blinkers. The Brain (Man), possessing only the functions invested in it as part of its development program, and being divided into several genotypes (and many sub-

genotypes), was limited to that level of target knowledge that was provided unequally in its capacity and depth for each class i.e. governing or governed. Besides, all people's comprehension and perception of the surrounding objective reality and the subsequent practical implementation of the realized when organizing their being, differed significantly not only on the basis of belonging to different Brain genotype, but also differed in the genotype group of the same name, because it also depended on belonging to one of the twelve tribes within each genotype. It should also be considered the fact that the functional purpose of each territory, formed by the System, played a certain role in the state of awareness of the surrounding reality by individuals identified exactly the same by the Brain genotype, and by their belonging to a particular tribe. ***This diversity is not only surprising, but also explains the lack of unity in the knowledge and development of people,*** significant differences in the organization of forms of being, the diversity of social control structures, the reasons for their emergence and structure, the presence of "national" development peculiarities and much more that we are already observing today with understanding of the ongoing. This is completely unrealized and not taken into account by all the previous and modern science, (including psychology, on which I emphasized), in the basis of their doctrines on the theory of the civilization development. These are the realities of today, which cannot be disregarded in order to move forward in development.

4.10. Influence but not power

Today, there are many who believe that in order for us to move forward successfully, so that our life would improve from year to year, and people see tangible results of this – first of all, we need a leader who would lead us to this bright future. Such a judgment removes many of the questions that people put! All bad things can always be attributed to the worthlessness of a leader; all good things can be justified by one's own labor for the benefit of something. However, a leader's role is not to invent all great ideas. A leader has **TO CREATE CONDITIONS FOR THE GREAT IDEAS TO COME OUT**. The phenomenon of leadership interested more than one generation of thinkers, scientists, researchers. And never among them was there a common view on the definition, essence and nature of this phenomenon. The theory of leadership originates in the 20s of the twentieth century, when there began to appear an interest in governing as science. The first thing that

researchers noticed is the possible presence of common character features among various well-known leaders. This is how the theory of characters, or the "Theory of Great People", appeared. Unfortunately, **THE THEORY WAS NOT A SUCCESS**. It turned out to be difficult to reveal common features. Of course, there was a lot in common – such features as high intellect, versatility, impressive appearance, self-confidence and so on. But a general portrait of the leader did not come out. People who do not possess the above qualities were also outstanding leaders. Why? There is no answer to this day.

Making of a political leader required its own system of concepts, adequate policy and technological implementation. The diverse scientific world of making national leaders for scientific and social life and political activities was described and presented both to scientists and people as a system consisting of type, class, division, department, order, family, human race and, finally, education, upbringing and activity of the leader. Each following quality was necessarily built, and today is built when solving issue on the development of the previous one. Replacing the content of any component, for example, type or family or some other one meant preparing a leader for activities not related to politics. This does not mean that, as a result of such a replacement, a bad scientist will be prepared, but only he will neither be involved, nor be interested in politics and public activity. Does it remind you anything of the present situation? True, since the beginning of the century, the reformation has given so many facts of the biologization of the so-called "leaders», which greatly puzzles with "boiling up" quite wild animal instincts and actions in modern leaders under certain conditions.

In the previous period, leaders were characterized by the fact that they were more a product of their personal labor than the influence of external factors. The leader's behavior was regulated, first of all, by service to the Truth, and this forced him to determine himself, his place in the world and relations with other people. His class of development was not determined by the requirements of a narrow profession and the need to act "like everyone else" (official statutes, job descriptions, professional standards of behavior, etc.). The measure of self-control, self-regulation, self-government and self-education determined the class of his development.

The leader's behavior is dependent of his mental state – like all people. He has to constantly maintain the balance between the two poles of mental state: positive and negative, otherwise called difficult or negative state. Only clear understanding of the psychological mechanisms of mental states can

save a leader from personal emotional instability. And it is very difficult, especially in today's misunderstanding of people and those who consider themselves leaders of the ongoing events. But it is time to make leaders, educate them in a completely new condition of world outlook.

Leader's education should include preparation for interacting with people in a variety of situations. He has to have the most powerful tool of cooperation with people – the ability of intellectual and psychological interaction. The leader must master the methods of coercion, suggestion, persuasion and proof, use adequately the specific situation, and for this the transformation of the Brain becomes primary. And on the basis of this, the assimilation of new knowledge should take place, which is becoming more and more accessible – but they are accessible today only to the prepared Brain.

Signs of a leader are associated with a clear formulation of the sense of his life. For this, he will have to answer questions of a particular way of life, his life position, his scientific worldview, and the current picture of the world. One of the peculiarities of making leaders, illustrated by N. I. Sazonov (1886), who in the last century, when working at St. Petersburg University, introduced criteria for distinguishing between knowledge and understanding, intelligence and mind, is quite acceptable today. The entire education system should direct its graduates to **UNDERSTANDING THE PROBLEMS AND DEVELOPING THE MIND**, *and not to the mechanical accumulation of knowledge and the perfection of the formal intelligence*. The quality of leaders should be determined by the information they create. It should differ sharply from the main information prepared for the mass consumer, by its objectivity, consistency, organization, sufficiency, readability, concreteness, practicality, necessity, but, of course, it should rely on new knowledge obtained from sources which I mentioned many times, including the works of A. I. Yuryev, as one of the few specialists today preparing such people, who considers, and I completely agree with him, that the leaders mission is conditional on their ability to goal formation. Goal formation is a complex phenomenon and consists of the following:

a) goal-setting based on the information and cognitive processes of society, rethinking the adequacy of the state of society;

b) goal direction, manifested in the nature of today's political parties choosing the direction of the society's development (although not capable of this today);

c) purposefulness, based on the volitional qualities of leaders and peoples encouraging to political change;

d) expediency determined by the real psychosomatic capabilities of people to achieve the goal.

If goal formation in general is differentiated into operational, tactical and strategic goal formation, ***then only political activity has as its object the strategic goal formation of society.*** And today this is the most interesting for our understanding. The ability for such outstanding activities as goal formation is achieved only as a result of educating leaders as public and academic figures of national and international scope. But in order to understand all this deeply, you have to figure out the main thing – ***what were the historical leaders-personalities through the prism of the energy-information dialectics of the Brain genotypes development?***

Many well-known historical figures are of ***genotypes 42 and 44.*** The Control Complexes, through the appropriate control servers, determining knowledge and "needs" for individuals possessing the executive state of "labor of mentals and assignments", which we have already mentioned, depending on the subsequent level and direction of initiating effect, **SELECTED THEM** (by the parameters of the Brain development) **AS CONTACTEE**. Each individual of this level (not of his own will) was especially functionally endowed with the **GOVERNED SPECIAL PROGRAMMED EXECUTIVE STATE** of "needs" and (through a strict energy-information identification based on its specific activated functions of the Brain) had to perceive, adaptively realize ***the presented to him from outside the external objective reality***, and only in the program-target format, as it was previously predetermined by the Control Complex. The program defined by the Control System and the process of its execution are to be completely identical. The main flow of information reception is carried out through the human spine of any Brain genotype. I note that today it takes place in the same way. Any command (information) perceived by the Brain can be manifested only after its identification. For this, some individual Brain functions of specific genotypes are endowed with their specific selective perception ability according to the so-called mantissas introduced

only for them. This selective Brain feature according to the mantissas provides guaranteed point of address and excludes the possibility of receiving information, decoding it and further subjective use by strange individuals, not related to a specific executing episode of the programmed process. However, today not all information is perceived and more so, identified by the indicated genotypes. And for some people, the Brain is simply "turned off" for such processes, and this is quite well observed, especially nowadays, in the "ruling team". A few examples: V. Lenin and L. Trotsky had a controlled executing program state of "labor of mental" in the programmed processes of revolutionary reconstructions. The executive-state "need and labor of mental" was possessed by the leading executors of World War II, Stalin, Roosevelt, Churchill and Hitler, since the entire strategy of implementing the episodes and stages of the war was carried out through them. The Rothschilds were able to comprehend and organize the primary basis for the future global financial system. The economic theory of Karl Marx had only one idea and one controlling function — ***it was a programmed manifestation for subsequent actions and future events. The FORMULA DOGMA ON SURPLUS VALUE***, proclaimed by him, was not a scientific discovery in economic theory, ***but a manifestation of the governing principle of the programmed process***, as the command to the executors on imparting a general state of execution, including the "power of money", to the universal and all-pervading start of violence in the whole sphere of the authority. This is one of the examples showing how the process of governing the execution of the programmed processes took place. Many historical figures had no theories, but programmed governing processes — the manifestations with subsequent organizational actions and future implemented events. This is extremely important to understand in order to move forward in your desire to comprehend the current processes today.



The Control System, taking into account the "pluralism" of perception and awareness of the commands, adjusted the Brain of the main executors in such a way so that in the end over a period of time all the main executors had a common opinion on the specific period of some processes with possible destruction of such a harmony in the future. There are countless examples of

such episodes on the international historical arena. Paradoxically, but it was possible to combine logically incompatible actions, and at the same time such facts always had relevance only of a temporary nature, i.e. for the period of execution of a separate program or program episode. A rather convincing example is the **TEMPORAL MILITARY UNITY** of the USSR, Britain and the USA for the period of the events of the Second World War and the subsequent **INSTANT CHANGE OF RELATIONS** at the end of the war. As soon as the information supporting control of the specified executive process was completed, another support immediately entered into force, causing completely different positional manifestations of the parties, followed by other actions and events, which were later called the "Cold War". Information has always been toughly tied to a specific executing program and is relevant and fair only for the period of its execution, no matter how long it would take in time.

In the Program of the Brain of those who were selected as a "contactee", the "Concepts of a step-by-step format" were laid, therefore the authority was called Conceptual. The control result of the execution had to completely coincide with the concept originally laid down. If the executor's actions did not bring to the event envisaged by the concept, the executor got a "kick". As a result, there could be either an "overdone", for example, the Brezhnev stagnation, or an "underdone", like Gorbachev's restructuring.

All those individuals, of a single or group plan, who were really, and not legendary, involved as true executors for the preparation and manifestation of the current or future events, could never be public. They should not be confused in any way with representatives of any structures of intelligence or Special Units, they should not be looked for at all and or be used as prototypes of literary characters and images. It does not depend on people! Besides, the System extremely toughly monitored the observance of a mandatory condition – simultaneous participation in actions at the level of the Conceptual Power and Structural one (Non-structural) **WAS NOT ALLOWED**. All this once again confirms the fact that it is ***excessively difficult to determine who is the truly involved executor at the level of the Conceptual power, who is the executor from the "historical scenery", and who is the initiated historical upstart or career figure.***

To understand the sustainability of the fact of information translation, transmission, receiving and decoding, the attempts to manifest everything

comprehended in specific actions (even if they are no longer relevant in the framework of the new program process), you can trace the activities of an American specialist in geopolitical strategies, etc. Polish-American – **Zbigniew Brzezinski**. Control Complexes through the appropriate control servers, when determining the level of knowledge and "needs" for individuals of the executing state of "labor of mentals and assigments", depending on the subsequent level and direction of the initiating impact, selected him (in line with his Brain's capabilities, as well as many well-known historical leaders and not only) for execution as a contactee. He possessed, not on his own will, basic information for its accurate realization through actions and events. Having fulfilled his mission, at the end of December 1990, he was simply turned off by the Alpine Complex as a used up element of the former system. But, as we see, he continued to disturb the world with his auto-motor-like skills as an old gramophone record, and he could never give anything fundamentally new until he passed away in May 2017, but had been in favor of the world policy until the 90s.



In addition, the Control System recorded both the current state of the execution process and the results of the completion of any going stage of the programmed process, but it did not always erase unfulfilled or incorrectly implemented commands. For this reason, there occurred special historical cases, which manifest themselves in the form of historical manifestations of untimely actions or events, but they were corrected in any case, no matter what counteractions were taken on the side of the executors who happened to stay too long. A relatively recent example is the attempt by the former President of the Ukraine Yushchenko to put into action the programmed processes, which had already been eliminated somewhat earlier and replaced by the new ones. Equal to this are the attempts of the President of Georgia Saakashvili to unleash the war in the Caucasus in **2008.08.08** – this was a programmed eliminated process in advance. **Such a "historical misunderstanding" is not the only one**, but it is not a failure of programmed processes, but the demonstration of the sustainability of the fact of information translation, transmission, receipt and decoding.

Often, knowledge from the Control System was provided in a distorted form and did not give an idea of the "reality" to unwanted individuals. This accounts for the periodic "bursts of activity" in the political, scientific, industrial or military spheres. Local or global confrontations in the actions of various "strategies" (geopolitics, domestic policy, manifestations of extremism in any form, etc.) were the results of the above. Any attempts to find out the truth, that is, to take the initiative in obtaining information, were nipped in the bud by the System and very tough. There were also failures in the Control System – Stalin, who intruded into the group of Marx-Engels-Lenin, who misinterpreted the program. Instead of carrying out "electrification", as a realized process throughout the country in terms of imposing upon people's Brain certain subordination, he went to the regions where the web density control was still insufficient; which he paid for. In the future, Gorbachev managed to correct Stalin's mistakes (to remove zones of weak control) and ensure Yeltsin executing the programmed processes "entrusted to him", i. e., imperceptibly removing the unnecessary population without its resistance and difficulties (being carried away by voucherization and obtaining such great "independence" as they could carry with separation and isolation from the former common). All this happened before my eyes, but at that time, everything was perceived in a completely different light, as the overwhelming majority did.

The current strategy of the political person formation is the most formidable force thanks to which the society lives, but thanks to which it can die, too.. The demographic and resource situation on the planet, caused by the ongoing changes in almost everything, including the life support system of people, has reached that limit today when all forces have to be gathered in the "quest" for the psychological laws of the modern man formation. And regardless of the understanding of controllability of everything and everyone, the human initiative, which manifests itself in the thinking of people more and more precisely in this direction, can only be welcomed and, believe me, will not remain unnoticed in the future. There is only one way out – ***not to simplify the technology of the modern man formation***, being aware of its extreme complexity. Actually, here it is once again appropriate to recall the foresight of N. Levashov in the creation of the "SvetL" Technologies, which in many respects help people today. National leaders can be trained only if it is based on strategic psychology, which is complemented by tactical and operational psychology. Of course, people have objective difficulties caused by living on "economically inexpedient

territory", which we are tried to be convinced with the erroneous course of the previous political, industrial and social development, etc., which the people "were led to" by the well-known leaders. I am saying it again and again – people are not guilty of the results of the events, but this is a rare case on the verge of exception, in which the "deserved" blame should be placed on a group of genotype 44, 46 executors of the Anglo-American-European superiority, because the real initiative in cruelty and ruthlessness in their executive actions was manifested much more than it was required for the ongoing process of implementation. **Overnight, this small group of adventurers and robbers destroyed all the centuries-old accumulated non-material values**, somehow characterizing the supreme spiritual purity of the natural essence of people, the majesty and mission of Reasonable Man, having trampled into the mud of animal vices and lowered to the level of derangement of mind all the subsequent intentions of the uncoordinated existence of peoples in the territory of the former Great Power. The overwhelming majority of the society is thrown to the misery of self-survival, and the **Will** and **Spirit** of the Great multinational peoples **are not only broken, but scattered in the dust**. And what is given in return? Nothing but ever-increasing lies and deceit on the part of the bureaucracy, seizing places in the governing class, who have still been trying to justify or hide all their deceptive and treacherous deeds and actions. It is precisely due to the imposed unprincipled, senseless, vicious and soulless state of the overwhelming majority of people in our society the illusion imposed on us of some Anglo-American-European civilizational global superiority, including the Great People of Russia, is still fundamentally supported. But there are many who realize that it is no longer the case. There is no former state of public consciousness, and there will never be a return to it, but temporary chaos in consciousness will soon run out, and this is irreversible – the people are no longer naïve and trustful blinds in the state of their consciousness! There is a limit to all this, it is supported by the System and it is irreversible!

To find oneself in today's new world reality, people (I focus here, first of all, on the citizens of Russia) will undoubtedly need courage and ingenuity. For this, it is necessary to "re-discover" yourselves, even to "re-invent" your mission with the help of the up-to-date, time-advanced education system, a clear understanding of tactical and operational psychology, which will expand the horizons of the ongoing events. And education should be understood **AS FORMATION OF THE FUTURE WHICH**

DETERMINES OUR PRESENT. The meaning of education, in which there must be invested everything that can be invested (including new knowledge) is *that man has to be given the knowledge – "why" he lives, and then he will overcome any "how" to live* – I am more than sure in this. With strategic psychological education, with an emphasis on new knowledge, which are becoming more available (and as an example of this – my articles and books in the broadest sense), there begins man's personal success and the success of the whole society. Today, by the recreated objects of the Control System (the territory of Russia) for the first time, the entire most complex process of the complete control of the Conceptual Power with the involvement of Man at certain levels of his co-participation (if man is thinking and striving for knowledge) is organized and being formed. This distinguishes such a Man in a completely different state of significance in relation to the future objective surrounding reality, connected with the formation of a different life on the Earth in all its aspects, known to us and not yet completely known, so far.

Chapter 5. To be in time – not to be late

From the bee's point of view, it lives its own life And only the bee-keeper knows that in fact the bee makes honey for him. But the bee will never know it, because the beekeeper is beyond its scale of thinking.

Modern people live in time, it is the time they value most, as if not noticing the space, which is hidden from them due to the Internet, telephone, car, plane. The world is presented to them in a spatially minimized form through the TV screen and the computer. Even earlier, before the appearance of these "deformers" of space, man turned out to be cut off from nature by a cozy dwelling, laboratory, and office. Mountains, rivers, fields have disappeared for him, and if they briefly appeared in his vision, then only as a distracting background for his psychological relief. He perceived them as the outlandish landscapes of unknown artists. Their role was completely different than those of the primitive hunter, shepherd or farmer, who were given life by "taming" the space. Today, man faces another task, which is absolutely the same for everyone: **"At all costs, to be in time, not to be late!"** The category of time in life, economics, and politics began to play an exceptionally important role. All existentialist tendencies in philosophy placed an emphasis on this concept, essentially changing the idea of it.

Global changes are changing the world, and if the world changes, then, first of all, the **REQUIREMENTS TO THE MAN**, who will live in this world, **ARE CHANGING**. Global changes in the world give people some reason for optimism and a chance for the maximum activation of everything human, and this is only beginning to unfold in them today. Knowledge and innovations are becoming the most sought-after, and people are somehow involved in their creation. Everything should be aimed at training highly educated, highly professional citizens of Russia as residents of a sparsely populated state with a vast territory. If such a strategy is adopted and implemented, then every man in the country will become a "single product of the educational process", the production of which should be maintained through the understanding based on New Knowledge and a new world view. No one doubts that mathematical or scientific knowledge is objective,

because they describe a reality that is independent of man. But the individual peculiarities of the world perception by people, and especially today, are so different that it is time to proclaim: all knowledge is subjective. And the reader, I hope, understands the meaning of the said.

Information presented in the form unacceptable for us is not perceived by us and is often credited to the category of useless and false. Many bookshelves in flats and houses keep a lot of textbooks, thick volumes of encyclopedias in mathematics, physics, chemistry, biology, psychology, philosophy, but because of the "inconvenient" form, they are practically not in demand.

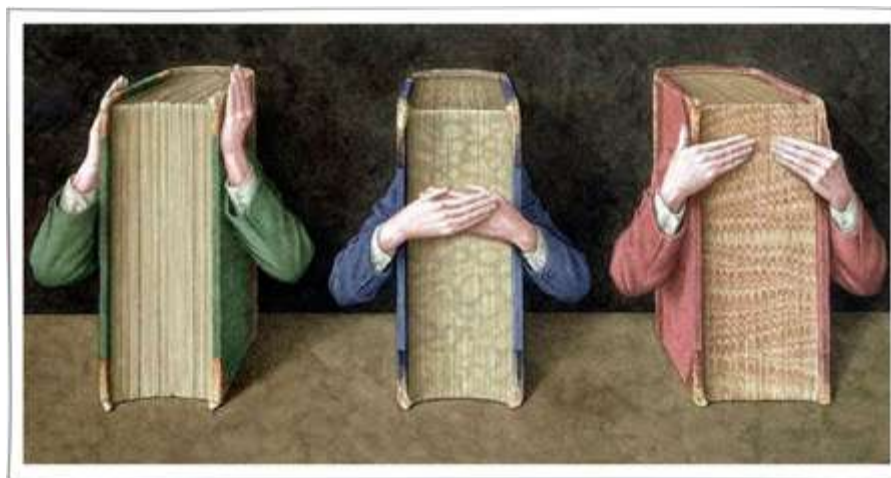

Keeping in mind this "unpleasant" property of books, I will try to give such a system of knowledge that would be of maximum interest to the reader of a constructive mind. A lot of people write to me about difficulties they have when reading the books by N. Levashov, A. Khatybov, A. Luchin, the materials by B. Makov, and mine, too, trying to combine them, being unprepared for such things at all. I also went through it at one time, even being familiar with N. Levashov and having read all his books. This is as indigestible as the combination of fresh milk, pickled cucumbers and fried whiting. This is where my wish to "fit in" with my reader, with his, if I may say so, intellectual stomach, in order to save him from indigestion. Of course, the best book for him will be the one written by him. And while there is no such a book, and it may never come out, my task is to give "intellectual food" in the most intelligible form. At the first stage of its cognition this "food" may be heterogeneous, like borsch or beetroot salad... It is important that it should still be compatible, subjected to the necessary heat treatment by the reader. And if it starts to work out, then you will gain the sensibility so necessary today, you will know your mechanisms of the world perception –

and this will allow you to avoid the fate of those many unfortunates who keep complaining that nobody understands them.

The core of training of a new generation should be the goal – one working citizen of Russia, under the conditions of the ongoing global changes and sparsely populated country should learn, work and live 10–15 times more effectively than people of previous generations – residents of the previously densely populated Russia. Only in this way will the whole human resource, which today is not in demand by mistake and seems almost a burden, be involved in the turnover. First of all, all this should be attributed to the younger generation of today, whose representatives are not going to do anything to develop their mind. **THEY ARE NOT INTERESTED** in any "New Knowledge" that they have heard of with half an ear or have not heard anything at all. They can be attributed to consumers of knowledge. They are interested in some extracts from this knowledge that can be used, for example, to write essays, diplomas, reports in those educational institutions and offices in which they are "settled", and also, perhaps, to guess crossword puzzles and other insignificant goals. These people do not concern themselves with solving specific tasks. Leafing through the books, they think about for a while what they have read, they can even discuss something with their comrades, but the intensity of their thoughts on one particular issue never reaches the maximum boiling point, when it comes to the realization that there were even harder times, but not that mean. On the other hand, among this mass of consumers, a small number of young people can always be found, especially fascinated by the bright light of natural science knowledge. They can be called not only consumers, but also creators of knowledge. They seek to see more profound truths than can be found in textbooks, encyclopedias and reference books. I know such people. Looking through the book after the book, they mumble to themselves with annoyance: "No, not that, not mine; these are too polished books. "Many of them begin to ask teachers with indignation: "When, finally, will they have any consideration for us and tell us about the real problems of science? " From the first group they **DIFFER BY CERTAIN PRODUCTIVITY**, in which, along with the shameless consumption of someone else's knowledge, there is an irrepressible desire to create something of their own , native, based on their personal mental experience, from their knowledge, sometimes gained by hard work and long search. It is out of such people that creators grow, often obsessed with a single idea, to which their whole being is subordinated. Such people, – I am talking about them either with respect

or with a smile, – are very stubborn and arrogant in life, because ***their present education is impeding them*** to correctly assess the ongoing events. All their troubles stem from their wide reading and correspond to the conviction of the stability of the knowledge gained. They are difficult to influence, and if possible, mainly through persuasion. Meanwhile, it is they who more than others need advice and sympathy, because in quick temper they are often not able to see woods behind trees. I feel like advising such people to take as a starting point the obvious things and move into the area of the unknown or poorly studied, and not the other way round. He is mistaken who bases his theory on vague, elusive images, empty concepts, controversial propositions to which he came, perhaps as a result of some religious sacrament, transcendental inspiration or just a hard night vigil, and then tried through dubious manipulations with symbols to "drive out" to the side of familiar things. A creative man, especially modern young man, rarely adheres to a certain strategy when he thinks about a subject of interest. Yet for a long period of time, one of the forms of his thinking prevails over all others. Of course, the type of thinking depends on the specific subject of the study, type of employment, depth and breadth of the education received, the surrounding intellectual environment, inner convictions, chosen ideals and the society's dominating values. All this conceal the already vague boundaries of the mental activity division. However, my personal experience allows me with a high degree of confidence to say that ***the gradation of knowledge accumulated by Mankind into individual sciences, disciplines, doctrines and methods is largely determined not by various areas of knowledge application and not by the sources of its occurrence, but by the subjective thinking process.*** Carefully exploring the form of presentation, especially of the New Knowledge, one cannot fail to see that man's own nature can play a tremendous role in the worldview of this or that man, even a young one, which we are talking about.

In this book, I am trying to identify the main ways of theoretical mastering of today's reality, which have to be turned into practice, relying on the New Knowledge, which in one degree or another became available. But all this largely **DEPENDS ON THE STRUCTURE** of the particular man **PSYCHE**. No one – neither he himself, nor even the most talented teacher, in my opinion, can change the way of thinking embedded in Man, like it can not be changed the preferential process of splitting food in his stomach from alkaline to acidic or vice versa. But I want to help readers "to see" the general structure of natural science, to get to know their own type of thinking, I will

try to suggest the way one could build one's attitude towards the happening events. The main ability of man is the ability to be carried away, and to be mistaken. When it disappears, it means that man dies. If it has never been, it means that he has never lived like Man.

5.1. Adaptation to the ongoing

There is a concept in computer technology – a depth of penetration. The submarine has a depth of penetration... The plane has an altitude of the flight. And man? A Creative Man has a depth of penetration: a scientist's depth of penetration is determined by the depth of knowledge in a particular science. An artist's depth of penetration is to show great insight into human character or another image. Everyone has the length of the way, but as for the depth...

Today's optimization of the human condition, which he undergoes (all of us undergo), occurs within the framework of changing the life support system of people and the Control System due to the phenomena that are not yet content of textbooks as such and psychology textbooks. There are psychological problems that scare man more than real hunger or cold. In the human consciousness, these phenomena are closely interrelated, because each of them enhances or diminishes the action of the other. In the letters that come to me from people of all regions of Russia, as well as from abroad, there are important observations of the current changes in human consciousness – the people write about themselves, their relatives, friends and foes. Against the backdrop of the resultant changes in the public consciousness, the following are either weakened or growing: a) fear of life, b) a feeling of loneliness, c) a heavy experience of boredom, d) deep apathy. All this, of course, affects both the worldview and the state of health. The appearance of these phenomena is perceived by many people as severely painful. The inner discomfort is mixed with the deterioration of interpersonal relations and, of course, the deterioration of health. This, of course, is reflected in the regular adjustment of the "SvetL" Programs that help in adapting to the ongoing events. We had to find some "formulas", based on which it could be possible "to ease" the main problem points:

fear of life is suppressed by finding the sense of life;
loneliness is overcome by finding the values of life;
life boredom is overcome by getting life purpose;

life apathy is overcome by acquiring vitality.

These are just some of the key positions that mainly influence the life of people. But rendering assistance to people during this period is extremely expedient. And in order to be able to assist, you have to understand what is happening. Actually, this is what I am writing for. Another thought, like "white horses" on a wave, catches the eye, gladdens, surprises, puzzles... Go on thinking further, look for a chain of events, go deep.., but – lack of time – either laziness, or not the right material at hand, or TV behind the wall is too loud. And so this crazy thought remains as foam on the rearing wave – the trace of the unknown depth.

The solution of human problems differs little from the analogous solution of problems in physics or mathematics. So, respected by me, Alexander Ivanovich Yuryev thinks. We talked a lot when I began working on the supplements to the "SvetL" Programs, which I mentioned above. I think his thoughts will be extremely useful to the reader. "Look", he said, "as the solution of problems in physics or mathematics is shown in formulas, **so in man everything is interconnected and can be shown as a formula**".

The psychological formula of man resembles the formula, for example, the well-known Ohm's law, where the current strength in a circuit section is directly proportional to voltage ($I \sim U$) and inversely proportional to resistance ($I \sim 1/R$). That is, $I = U/R$. Human psychological problems are also a closely related system, **where boredom is directly proportional to fear of life and inversely proportional to loneliness**. If the power of the electric current (P is work of the electric current per unit of time) is calculated using the formula $P = UI$, then the apathy of man can be calculated as **the product of fear and boredom**.

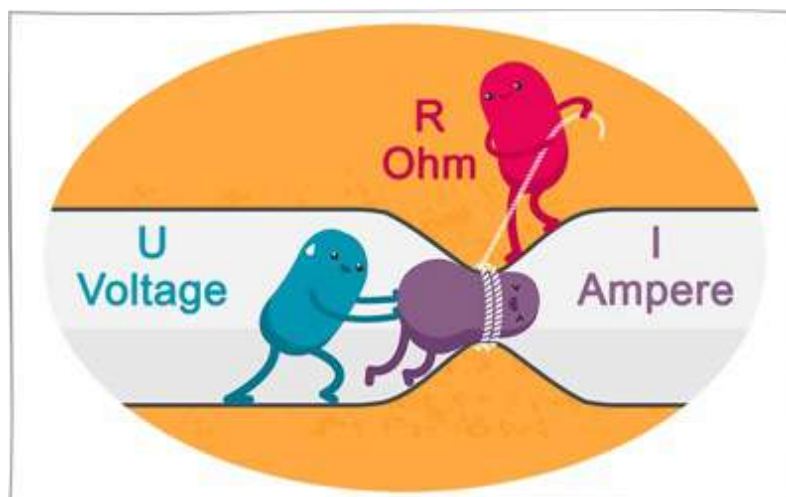

Then the solution to the problems of Man, which we considered above, is as follows:

1) if fear of life is suppressed by acquiring sense of life, then the sense itself is the product of the purpose of life and life values (when you know what you want in this life and you know what you have to do – fear of life disappears);

if loneliness is overcome by finding the values of life, then the values of life themselves are quotient of sense of life and its purpose (loneliness is formed if what you achieved in life does not correspond to what you really want from it);

if life boredom is overcome by the formation of the purpose of life, then the purpose of life is the ratio of the sense of life to its values (boredom is caused by the impossibility to achieve the desired with the general incomprehensibility of the purpose of life).

And if life apathy is overcome by acquiring life vitality, then life vitality itself is the product of the sense of life and its purpose.

5.2. Orientation in a state of being

In today's society, a sense of anxiety and danger is growing, but the sensation is forcibly suppressed by the propaganda barking from the media. Obviously, the majority of people, from top to bottom, get economic, social and biological blows from the real world, but the citizens downtrodden with taxes and political advertising do not even understand that they are being beaten. They are beaten by those who are already doing something in a auto-motor-like way, but do not understand what and why. And people do not understand who is beating them and what for! They can not assess what is happening, because the fictional – that is presented to all of us, – seems more real than the real, and any real can become even more ephemeral than the fictional, metamorphosing without any shores and carrying along the flickering Mind of people even deeper into mad metamorphosis of hallucinations.

In the modern world, as it seems to many of us, there are no real foundations, because they are replaced by short-term installations, and there are no understandable eternal words, in the place of which now there are smoke-colored connotations.

Being in this unstable state of consciousness, creative people, potentially capable of building spaceships and exploring the cosmos, work as waiters and bank clerks, cashiers and security guards. However, today, they, first of all, and many others, have questions that have begun to stir the mind. Why is everything built around deliberately irrational, unnatural and

disgusting? Does such a social structure have a reason? The question itself is important and interesting, in the framework of a non-superficial understanding of what is happening today, and it arises most often as a subtle flash in the head. But the flashes are getting more frequent, pushing to search for the answer to the eternal question – "what is to be done"? The problem, meanwhile, does not go away by itself, and it will not go away. Without real knowledge and understanding of how Mankind works in a national and global format, any rational action on the side of the people is out of the question.

In what way do we see the world of officials, political scientists and the canonical world? Here, for example, modern citizens of the so-called democratic countries, including Russia, whose Mind is sterilized by the global media machine, receive this information in strict dependence of the level their mental development is at. However, there is also **SOMETHING "BASIC"**, which reaches an average man at each of these levels and is supported so far, but with some frenzy, in all imaginable and unthinkable ways – **THE WORLD IS INITIALLY AND FOREVER MADE UNFAIRLY**. People have different capabilities, and therefore everything in the world is predetermined as in the Oriental parable: *people are raindrops; only a few fall on the palaces, and the rest -on the rice fields! They must live in line with the written law! The law is harsh, but it's the law! To each his own! All power is from God! Follow commandments! Observe the law! To Caesar's – Caesar's! Resign yourself!* This kind of stupefying stinky swill people consume from a variety of sources: scientific texts, sacred revelations, the media and archives. I will try to present to the readers a kind of psychologically conventional gradation of consumers of the so-called political science information.

The picture of the world for the unwilling to go carefully into the point (suffering from a deep form of dementia).

For these, dull-witted citizens, the surrounding reality is presented at the "country's", national level. There is, they say, our country and there are some others. They all compete with each other, enter into alliances and even fight for their national interests. At this level, an inhabitant is firmly convinced that there are **RIGHT, DEVELOPED AND DEMOCRATIC** countries, but there are also *"the rightest" among them*. At this level of

mental development, citizens sincerely believe that the way to improve their lives is to develop a creative economy and democratic institutions, go to the polls, pay taxes, live by the law, sue a lot and reflect on their gender⁶⁰, be tolerant and fight corruption. Or else they reject all this entirely, creating the



opposite pole of "inter-idiotic polarity". At this rudimentary mental level, some are even able to think in "historical" categories, they are proud of their country, its songs, dances, military victories and modern achievements. They clearly identify the enemies of their country and the enemies of the same stock, as well as its friends and

allies. At this level of mental abilities, it is not that important from which sources the citizens got this knowledge, but it is important that they take it sincerely at face value.

The picture of the world for those who pretends to go carefully into the essence and try to get to know (those suffering from moderate oligophrenia).

If the inquisitive mind of some particularly curious earth dwellers is not ready to be satisfied with such primitive pictures of the world, as described above, he is presented with slightly more intricate political patterns of "ideological confrontation".

On the heads of the poor philistines whole buckets of swill are continuously poring out about the activities of liberals and conservatives, of the right and left wings, opportunists and radicals, moderate greens and feminist extremists, LGBT activists⁶¹ and homophobes, Nazis and anti-fascists.



The world in the eyes of a philistine who has extracted from this puddle of knowledge turns into a multi-colored boiling up **SETTLING TANK OF VERBAL GARBAGE**, where the so-called populace, parties, social action

⁶⁰ The concept of gender covers the range of psychosocial and sociocultural characteristics associated with the male or female sex within a particular culture, and the ability to use this knowledge in practice.

⁶¹ Socio-political LGBT movement (lesbian, gay, bisexual, and transgender).

groups, public opinion leaders and other individuals and organizations are supposedly acting as subjects. At this level, citizens discover strata (social strata), classes and masses, the theory of "separation of powers" and the form of state structure. They actively comprehend in what way a parliamentary-presidential republic differs from a presidential-parliamentary republic and why a constitutional monarchy is better than an absolute monarchy. At this level, citizens get to know that there are democratic states, legitimate and illegitimate elections, authoritarian and totalitarian regimes and, I'm not afraid of this word, dictators! At this level, such a fast-food propaganda as the Holocaust, the famine and the "Stalinist repression" is easily digested. At this level of self-consciousness, an average man is already able to identify himself ideologically, proudly declaring that he is a "patriot", "cosmopolitan", "statesman", "marketer", "expert on New Knowledge and works of N. Levashov", which he boldly carries to the masses, denouncing those who, in his opinion, "makes profit" on the heritage of the Great Russian scientist, cheating everyone and everything, etc., etc. A man in such a state of mind can proudly believe, that **he has become a real brick in the foundation of modern civilization, and some of them even – the elements of its facade decor.** However, not everyone can be tricked by pouring ideological broth into his brain. Any average citizen who has heard the parliamentary debate at least a couple of times will immediately stop believing in fairy tales about democracy, class struggle, equality or social partnership, the existence of ideological differences and the rationality of ideological concepts. And this is a true fact today. **The world is for "others"...** (suffering from mild mental handicap), according to the apt remark of Russian Foreign Minister S. Lavrov. I note that I have found more than 90 synonyms for this voluminous and originally Russian word... so, no offense, reader.

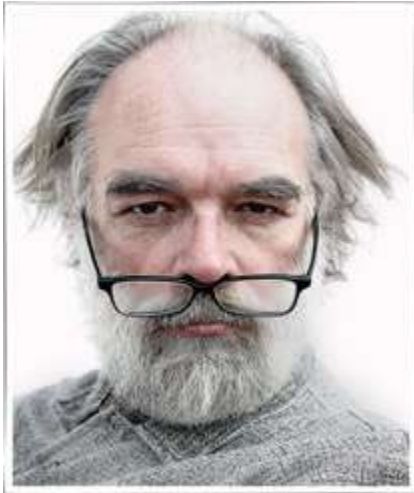

“**Others**” are the smartest of the weak-minded. As soon as such a citizen, curious and suspicious, appears he gets a new picture confirming his doubts and raising him in his own eyes over the underdeveloped fellow citizens. And that very moment he begins to doubt about the ideological illusion he is immediately provided with partially revealed sacred facets of the universe – religious and ethical teachings, mystical practices, sects and

confessions, history of world religions and confessional rivalry, sacred writings and revelations of the prophets... The choice is inexhaustible. Only a few keep their head clear when they are shown how presidents and prime ministers whisper about something with their confessors, and political and economic elite of humanity under the night cover enters into regular intercourse with the "Evil spirits" and is consecrated into secret lodges exposing themselves to all sorts of extreme initiations. At this level of understanding of reality, a proud bearer of sacredness and secret knowledge is about to proclaim: **"I am an old believer!"**, **"I am a true believer!"**, **"I truly believe that there is no God! "**, etc. Such fabulous texts as the theory of the local civilizations cycle, the doctrine of a "clash of civilizations" or a tale of a thousand-year opposition of thalassocracy to tellurocracy, etc. are absorbed with pleasure at this level. Citizens eagerly talk about geopolitics and an international strategy. In the imagination of citizens, the images of I. Stalin and F. Roosevelt, V. Putin and B. Obama, A. Merkel and D. Trump, Jesus Christ and Mahomet, John Chrysostom and Moses come to life. At this level, carrier strike groups, aimed at "underwater hunters" with nuclear missiles furrow the seas. At this level, strategic alliances are being created and destroyed in the heads of the citizens and new civilizations are being created. But real life does not correlate with anything like that. Anyone who was not too lazy to ponder over geopolitical strategies and "cunning plans", read canonical fooling books of A. Toynbee, Z. Brzezinski and D. Huntington, who did not fall asleep over the "Old" and "New Testaments", the Gigas Codex ("The Bible Devil") or "Upanishads" and such modern "books", as "Special operation "Ringling cedars of Russia"", written by a married couple of "experts of N. Levashov and his knowledge" in the absence of their own one (I am not writing the names, they are known in certain circles), – sooner or later begins to understand that all this rhymester, in principle, does not differ from children's fairy tales about Emelya, Ivan the Fool, Cinderella and the Snow Queen. Is it only deliberate boring with the inescapable feeling that the plots of these manuscripts are inspired by delusion rather than Providence? You will not figure out anything in all this "lives of saints and the advanced" without a glass of vodka and the Talmud.

And finally, if a citizen **PERSISTS IN UNBELIEVING**, he is raised to the highest level and heavy figures are brought into play. For such a man

the veil of conspiracy⁶² is slightly opened. If he previously believed that international organizations were a product of a legitimate treaty of sovereign states, now he begins to realize that countries are only projections of some unknown interests. If earlier he thought that McDonald's and Macintosh were pies and telephones, today he already understands that these are transnational corporations (TNCs), the might of each one exceeds his native country's potentials. In this regard, the omnipotence of international organizations was particularly vividly demonstrated by the "exemplary flogging" of the powerful nuclear state, the Russian Federation, arranged by the corrupted and rotten-through International Olympic Committee compelling its athletes to perform at the Games under the white banner of surrender. But this is my opinion, and it can be subjective.

Even a narrow-minded philistine mind after certain training can easily catch a systematic regularity: no official institution functions within the framework of organizational regulations and official positions. Behind any official facade **A SHADOW REALITY LIVES**, which provides the management system – from the UN (United Nations) and brain trusts, international unions and parliaments – to presidents and prime ministers, up to the village councils and territorial self-governing communities.

But as soon as a philistine begin to suspect a trick, megatons of semi-true or false information about terrorists and pharmacological mafia (which, of course, is the case), masons and illuminati, archaeological artifacts and historical hypotheses, occult knowledge and made-up prophecies of all sorts, molfarov⁶³, good witches and psychics pour out on his head. This information is deliberately stupid, mixed with real and falsified precisely to the extent that it turns interest in searching for true answers into occupation in a certain way shameful, as people who have helped me with the "SvetL" Technologies have often been convinced by their own experience. Any attempt to truly get to know the "behind the façade forces" and shadow processes is qualified as "conspiracy" in a bad sense, and too much curious citizens are exposed to blackening, professional, political and scientific

⁶² Conspiracy (literally: "conspiracy doctrine (science)" is a concept announcing certain socially significant events, certain historical phenomena or even the course of history as a whole as a result of a conspiracy by some group of people who manage this process out of personal gain, ambitions or other group, clan and other interests.

⁶³ Molfar – a man who is believed to have supernatural abilities – a healer, the bearer of ancient knowledge and culture. Molfars are engaged in healing, manage the forces of nature (for example, the weather), using spells, special objects, herbs.

ostracism, and sometimes physical elimination. One of the favorite techniques is trolling – defaming on the Internet with direct insults in the hope that man will not stand and start a polemic with those individuals who have neither conscience nor honor, not to mention knowledge. As for conscience and honor – read below.

In order to instill in mass consciousness a sense of reality of some false fact, event or phenomenon, traditionally there was used such a technique as its recognition of ancient, traditional, sacred, generally accepted or scientifically proven, etc. This is the way the old control System was built up, which those through whom all this was implemented into reality (genotype **42, 44**) , considered and called, for example, the Supranational Control Syndicate, rallied around goals unknown to mankind, but no one officially recognized its reality. There are Supranational and Transnational structures in the “official” picture of the world, but their real roles are hidden from the population, the tasks are not publicly discussed, they are deliberately embellished or profaned, and their true influence with Mankind’s life are many times understated. As a result, citizens of all countries, including representatives of national elites, sincerely believe in laws, democratic procedures and international agreements according to which they have not lived a day. Meanwhile, in their eyes behind their windows, life develops in a completely different way, and there are many who are beginning to understand this independently of the specific groups I have mentioned above.

One of the basic factors supporting the omnipotence of the Control System through Globocratia was and still remains – ***a universal denial of the recognition of its existence.*** In practice, this looks like a denial of the obvious. Political scientists, experts and all kinds of analysts act on the field of national states, denying the dominant organizing power of supranational and transnational structures. TNCs and international organizations are taken into account only in their officially declared legitimate status. In the mass consciousness, **FALSE CONVICTION IS SUPPORTED** as if there are intelligent and stupid nations. The former, they say, are able to organize their own states in such a way that they help people to improve their lives and achieve competitive advantages, while the latter are doomed to be victims and forage base of the first – smarter and more successful. For example, most Americans are instilled as if they are great, and most Russians – as if they are clever because Americans are

stupid. This feeling is irrational in its essence, but it has and still will have significant consequences manifested in the real world.

If, in our thinking, we believe that the first answer is correct, then all our efforts to "enlighten, give New Knowledge, raise the masses" will be doomed to futility. But if we consider the second answer to be true, and we actually know that it is true, and then this means that we confronted with **the paradox of D. Rumsfeld**, the genius and undeservedly slandered former US Secretary of Defense, the smartest man, already mentioned in previous books, and a creative innovator.



This paradox was formulated by him in the book "**The Known Unknown**". I mentioned it in the first book. Naturally, the traditionally dull journalists did not understand the basic thoughts of the Pentagon chief and distorted them, and the author of the book was spat upon and slandered. The thought of Donald Rumsfeld goes like this: "There are **known known things**. These are things we know that we know about them. There are **known unknown things**. These are things about which we know that we do not know them. But there are still **unknown unknown things**. These are things that we don't know that we don't know about".

It is this that people of honor are confronting today – people who, in spite of everything, strive for knowledge. These are those who are worried about the current situation in society, when the truth, justice, striving for social progress, solidarity and creation are purposefully and inexorably squeezed out, burned and cut out of our lives by fire and sword and so-called intellectual and soft power in the face of political scientists, sociologists, historians and journalists. Their task is to fool and anesthetize the population, to pollute the brain of every citizen with informational garbage, not allowing him to see what is really happening behind the advertising

boards. With the help of special technologies of mass impact, people are being turned into a stupefied crowd – a collective imbecile (morons, fools, idiots). In fact, ordinary people are not stupid, not elementary, not drunk, not jellied, not pot-headed, as they are called by propagandists. Ordinary people cannot understand and undertake anything, as they are victims of manipulation, victims of global mystification, victims of false suggestion and purposeful duping. And this, unfortunately, is the fact that can always be verified through communication with people. Accordingly, I set myself the task, proceeding from this – to enlighten, prompt, support. To tell people, for example, that the so-called political scientists willingly lecture, reason and phrase mongering about world and national strategy, easily "move" troops on the world map, imagining themselves in the place of D. Trump, A. Merkel, V. Putin or P. Poroshenko. They easily play political patience within any country, but none of them **WILL EVER MAKE USE** of their own recommendations on the political and social field. ***The task of political science, as, indeed, such a pseudoscience as economics, is to DISTORT REALITY.*** The social, allegedly, sciences of our day, have no practical sense other than falsifying the object of their supposedly scientific knowledge. Their many ideas untested by practice, turn into stinking silage. This pleiad of "teachers" understands perfectly well that if people clearly understand the real structure of society, see the real picture of what is happening and can make conclusions from all of this, then they quickly and without much stress realize how ridiculous their claims are to their own governments and deputies. Realizing the real place of the "shepherds" (the so-called national elites) in the human hierarchy, any reasonable man can easily understand why the state or local authorities are never engaged in improving the lives of their citizens-voters who "elect" these authorities.

Let's go further. If someone offers something to someone, but of no avail, the explanation should be chosen from three options:

- 1. *The profferer is wrong.***
- 2. *The proffer is wrong.***
- 3. *The wrong ones are proffered.***

Going through these options in search of the right answer will not be problem. If you follow the way of the truth, those who are willing by personal example to sacrifice their own interests for the public good, the proposal deserves full confidence. So there are no problems with those who proffer. Though there are not so many real people of honor, but they exist, and there

is no point in questioning their sincerity. N. Levashov did it throughout his life, and all my Friends and Like-minded people and myself, and especially those who help me write my articles and books, strive for the same.

5.3. Problems solution

In order to understand something that worries us at our current level of development and interpretation of the ongoing, it is best of all to turn to our Russian historical classics.



Fear of life is described by L. N. Tolstoy in the epic novel "*War and Peace*". It was for this purpose that he introduced Pierre Bezukhov into his novel as a character. The writer meticulously analyzes Pierre's thoughts when he was depressed after all his ordeals in French captivity. L.N. Tolstoy writes: "Sometimes Pierre recalled the story he had heard, telling how soldiers in the war, being under firing in the cover, when there was nothing to do, diligently seek for some occupation in order to endure the danger easier. And Pierre imagined all people such soldiers, **ESCAPING FROM LIFE**: to ambition, to cards, making laws, women, entertainment, politics, wine, state affairs. There is neither insignificant nor important – all the same; if only to be able to escape from it! – thought Pierre. – If only not to see it, this terrible life". Such thoughts came to people's mind long before Leo Tolstoy. For example, **B. Pascal**⁶⁴ (1623–1662) wrote about the fear of life problem in relation to his time: "I don't know either the one who created me, or what this world is, or what I myself am. I am in total ignorance; I do not know what my life is, what my feelings are, what my soul is – the part of me that thinks what I say, who thinks about everything and about itself and knows itself no better than

⁶⁴ Blaise Pascal (Fr. Blaise Pascal) – French mathematician, mechanic, physicist, writer and philosopher. A classic of French literature, one of the founders of mathematical analysis, probability theory and projective geometry, the creator of the first samples of calculating technology, the author of the basic law of hydrostatics.

anything else. I see those terrible spaces of the Universe surrounding me, and I see myself bound in one corner of this immeasurable infinity, and I don't know why I am in this place and not in another, and why that length of time, which is called life, is tied to this, and not to another point of eternity, which preceded me and which will be after me. I see around only infinity that embraces me, I am like a shadow that lasts one instant and does not come back".

In our time, the problem of fear has not disappeared, but intensified.

Our contemporary, an outstanding futurologist **A. Toffler**, writes *about a new form of fear of life – fear of future, the form of which is very relevant today:*

"Under the influence of new experiences and sensations, a mentally healthy man ceases to distinguish the real from the artificial. He loses the ground under his feet, for the very definition of a normal psyche, a normal life is no longer considered



normal. The flow of changes brings unprecedented complications in the lives of people who become victims of futuróshock. In future, the world is in store for Man in which there is nothing in common with the world to which he is used. <...> If only one technology broke loose, even then our position would be difficult enough. The deadly danger is that other social processes have unrestrained and are rushing madly in an unknown direction, refusing to submit to all our attempts to control them".

Fear leads to exceptionally severe forms of escape from it through drunkenness, drug addiction, gambling, and violence. Although society and, of course, its most progressive people have been doing their utmost to find the antidote for fear, it rises from the ashes again and again. The most known remedy for fear is to take man away from the real world to the world of illusions with the help of entertainment, press and art professionals. This is where the "ruling elite" everywhere is trying to escape from hopelessness and its own auto-motor-like state. But the action of illusions is short – fear, unfortunately, returns to new generations of people in new forms and with new content. From time to time, fear drove people to mass disobedience to everyone and everything. If the authorities were not able fulfill their

protective function, and then the masses of frightened people overthrew dynasties, regimes, and governments. So it was under the old Control System.

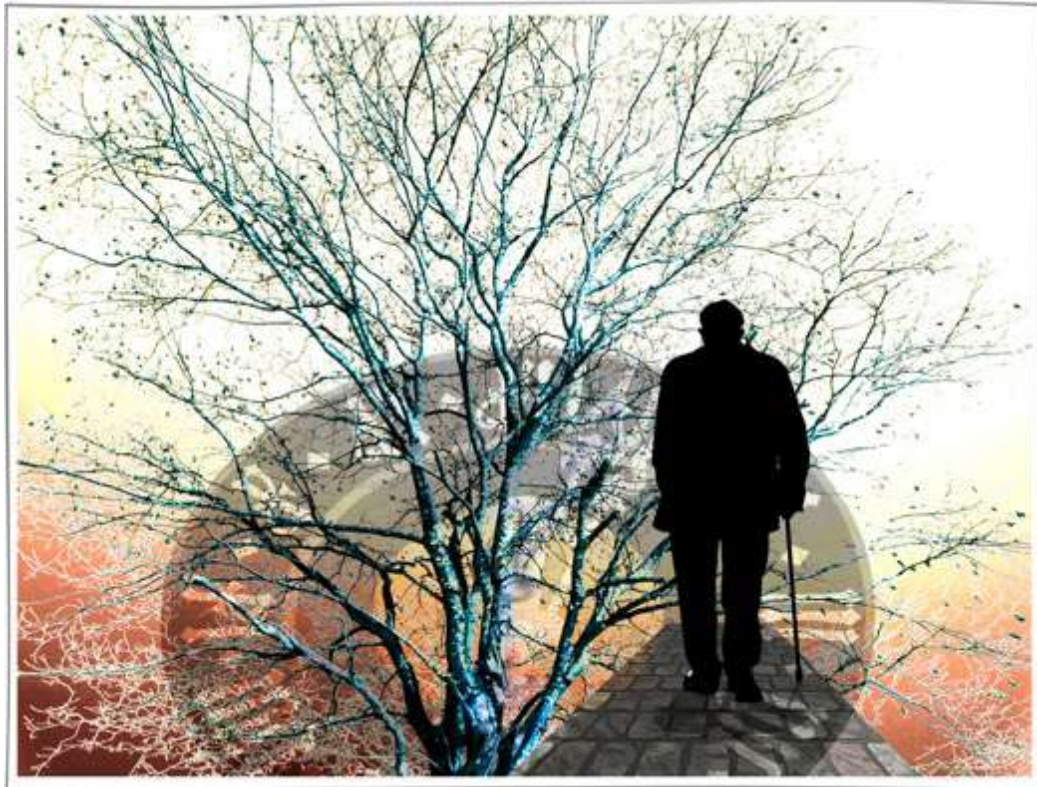

The antidote to fear of life is not a secret – it is the purpose of life in the true sense of the word. For centuries, mankind has been struggling with varying success over the wording of the sense of life – the only and universal remedy for fear of it. At each historical stage, the problem of the sense of life was more or less successfully solved, generating a lot of optimism and enthusiasm in the development of science, technology and the arts. But all this occurred only to achieve the goals set within the framework of the Old Control System.

Nicolai Levashov, and in my opinion he was right, when we talked it over, emphasized – **THE SENSE OF LIFE PLAYS THE ROLE OF THE MOUNTAIN**, from which you can see endless living space and apart from lurid dangers and disgusting events, they are *frantically full of joy*. Life from the pinnacle of the sense of life brings to such pleasure that compared to it, alcohol, drugs, etc. are nothing. However, to build up that pinnacle of the sense of life is incredibly difficult – this is the most difficult task that Humanity has to solve for survival. Nevertheless, it can be solved. ***And the deeper the sense of life, the higher the pinnacle and the weaker the fear.***

Loneliness makes man purposeful through the need to overcome it. Nicolai Levashov defined loneliness as an experience that evokes a complex and keen sense that expresses a certain form of self-awareness and shows the split of the real relations and connections of the man's inner world. Yes, it is difficult, but it is Man who is complex, and you can not simplify the dialogue with him. The problem of loneliness is so fundamental, but known so little that many people are not ready to associate it with the ongoing events, because, when plunging into loneliness, they automatically distance themselves from the present realities.



Values of life versus loneliness. The way to overcome loneliness also does not make any secret – these are life values that attract other people to man. There is nothing artificial in life – all relationships between people are rational, practical, and careful.

If man does not arouse interest in himself, if he gives nothing to those around him of what they need, which would attract one or many people to him, he will be alone. The reasons for loneliness are **ALWAYS HIDDEN IN THE LONELY MAN HIMSELF**. As moths fly to light, so people are attracted to man with signs of what are called values. Values are a set of such qualities of man, that make up his intellectual, moral, material, and aesthetic wealth, which he can share with others, and if we add to this the New Knowledge that has opened up to this Man, even in the process of loneliness, it is a must for him to share it with the people around him. Thanks to these values a certain group of people is "saved" near such a man "breaking

through" his loneliness. Strictly speaking, values are a certain number of properly connected moral and intellectual principles that perceive the sense.

Values are real transformation of the sense into specific actions. These are not philosophical abstractions, as many people think, but values, in which New Knowledge is incorporated, revealing to people – the most high-quality products that today's society creates. The composition and structure of values continuously adapt to changes in real life, but they are all secondary in relation to the unchangeable constants of man's life: love, faith, aspiration for knowledge, hope and work.

Boredom is mistakenly taken for an everyday life problem, although it actively encourages man to "politicize". A. Schopenhauer pointed out this mistake, who wrote: "In life we constantly balance between grief and boredom". Psychologists, who I talked this problem over, believed that happiness, apparently, is somewhere in the middle: **so that the pungency of new impressions would not begin bringing unbearable pain, and boredom would not seize to death.** It should be emphasized the importance of A. Schopenhauer's remark: "The deeper the grief, the longer the boredom". It is boredom that stops public, research, personal processes, bringing to stagnation in all spheres of society. Man intuitively tries to fight boredom, which leads to degradation of his personality, to plunging into primitive and criminal forms of behavior. If he fights – it means that he is politicized.

The purpose of life against boredom. Boredom can be more deeply and accurately imagined as an emotion that arises if man is not able to find interests and activities that can capture him completely. We can assume that neurotic boredom is a state of instinctive tension, in which there is no instinctive purpose. As a result, man who feels boredom is looking for an object "not to direct there the actions of his instinctive impulses, but rather the object help him find an instinctive purpose that he is deprived of". **He knows that he needs something, but does not know what.** Hence irritability and uneasiness are inseparable from boredom. Often boredom is called a special mental state of an individual, associated with emotional hunger. But only very few, including N. Levashov and A. Khatybov, as far as I know, truly called the real cause of irritability and uneasiness because of boredom – **NO PURPOSE OF LIFE. A Purpose is a device for transforming sense from the static state into the dynamic one through values.** The process of this "transformation" is something similar to an electric current in the network. There is current

(purpose) – there is a conversion voltage (sense) in the light of lamps (values). Current, like voltage, are hidden from the consumer: the values "shine", "rotate", "give heat", they are visible and perceived, they are paid for and thanked. But the goal, like current in the network, is real, it is formed, measured, regulated. And now try to transform what has been said into an understanding of the "target vector" through which the tasks are solved within the framework of the New Control System.

Many people realize that the purpose of life cannot be “invented” in isolation from the sense of life and life values. After all this, is it necessary to remind you that the purpose (target) is the most complex product that is created by society, and not only by society, but also by the realized Target Vector within the Control System in a specific historical span of time. It is in the purpose that all the achievements of mankind are implemented. But it is precisely the purpose that suffer in the first place, when humanity loses the sense of its existence and the values that ensure this existence. Lost purposes are immediately replaced by pseudo-purposes, which are engendered by Fuhrers, sects, gurus, authorities and other “characters”, but, as you already understand, only within the framework of the tasks of the Control System for the period.

Apathy is underestimated by others as a kind of easily banished whim of a slacker. Or a kind of laziness, which is of no danger to anyone other than close people. This is all wrong, because apathy is at the same time a state problem and an indication to man's disease. When the masses of people fall into apathy, and they fall by the "order" from the outside, then the country falls into



apathy, then it drops out of the global process of change, leaving the world historical arena in accordance with the program process within the Control System. Anyone can get to know that apathy in Greek means impassivity, that is, a state characterized by emotional passivity, indifference; indifference to events of the surrounding reality and weakening of motives and interests. Philologists add to this impassivity, unfeeling, indifference, unconcern, equanimity, coldness, inertia, lethargy, laziness.

Vital force against apathy. Physiologically, man is always able and ready to actions, but does not do this only **BECAUSE OF THE LACK OF A SENSIBLE PURPOSE IN THEM.** ***The problem is only in the start up of the volitional mechanism.*** For the purposes of dialogue, you can simplify the “ordinary man’s formula” up to the analogy, as we have already considered, with Ohm’s law formula for the electrical circuit. There is nothing simpler: the electric current I is equal to the quotient from dividing the voltage U by the resistance of the circuit R , that is, $I=U/R$. The main thing in the formula is that ***each variable performs only its own function, and all variables in Ohm’s law are interdependent.*** Something similar in a very simplified version occurs in the human consciousness. And consciousness can not be empty. It is not the consciousness of people that determines their being, but, on the contrary, their social being determines their consciousness. So Marx thought, or rather, everything was done so that people would think so and accept statements of this kind, and more so, of such authoritative figures. This way being has been built, which determines nearly everyone’s consciousness to this day. And one should not forget that the old System had no strategic and target orientation regarding the development of people other than the **DEVELOPMENT PROGRAM FOR THE BRAIN GENOTYPES.** In the course of the fulfillment of this program:

- the overwhelming majority of people were deprived of any sense of life, they lost their sense and purpose orientation of their existence;
- there was an indirect program control from the outside of all values that permeate all aspects of human life and society;
- the sense of being of people without voluntary and independent awareness of their will and desire was predetermined;
- there was no sense in people’s being in the stage-by-stage direction of civilization development in their limited and the only application as material to be thrown away.

All this gave rise to fear, apathy, boredom, loneliness, and a lot more of those we are reaping today.

5.4. Physics of the past in today's throwback

The XX-th century programmed processes, excessively hard in scale and intensity, extremely bloody in their inhuman target nature, completed the way of several millennia, and the going chronoprocess had a global in time Target Vector – ***creating and perfecting a specific human Brain genotype*** in the programmed quantities by the required time for the purpose of linking with the Brain of the invaders. The imposition of alien (non-human) Brain functions was carried out through the execution of ***the Energy-Information Dialectic Program of the Brain genotypes development***, and all the corrections of the flesh cell, imparting complete controllability and harmony of the modified Brain and the perfection of the human flesh were executed through ***the Program "Development of the Energy Biogenesis of the flesh cell"***.

I'd like to emphasize that the entire history as the program for the Brain genotypes development, is the **BASIC LAW OF HISTORY**, and not anything else.

Let me remind you, readers, that since **1605 BC**. (the cupola period regarding objects of type **440** and the entire subsequent period) **up to 2009** inclusively on the side of the old System, ***a programmed process of step-by-step controlled "Brain development" was carried out among selected groups of individuals from the whole existing community of people***. This process was aimed at imparting these people such a specific Brain state, which would have some similarity to the Brain of interventionist "imported" individuals, would have the state of the **COMPLETE NON-ALTERNATIVE OBEDIENCE** to all the control processes carried out by the System, would be able and applicable in the program of changing its complex condition related to the change in the level of octaves for the purpose of further use according to their programs. The system needed **ONLY HUMAN APPEARANCE** for the individuals it created, ***but with the "spider's" Brain***. Thus, in total **22%** of the population of the Earth was involved in this process, and this part of the population has ***only external human-likeness!*** In the course of this time, the functionally specialized "constructions" of the modified Brain of people were "developed and imposed on" along with improving the interventionist Control System itself: genotypes 42 (421, 422 and 423 – the Caucasus Control Complex), genotypes 44 (441 and 442 – the Alps Control Complex) and Brain genotype 461 (CC California). Each subgenotype, in

turn, is presented by 12 "Tribes" that have different thematic states of the Brain functions for receiving highly specialized information for its identified target application, both of cognitive and controlling nature. The involved individuals with the imposed Brain genotype, receiving gradually dosed, as if "being improved" information of a cognitive and controlling nature, were applied to specialized executing activities within the framework of specific milestone Target Vectors. Such individuals possessed some distinctive features in behavior and preferences associated with participation in the management of various program orientations in the spheres of organized being, scientific and religious spheres, in the narrow professional technological orientation, protective and some other areas that distinguish them from the general mass of people by something pronounced, visible and recognized reasons of behavioral and other character. This, in turn, was an essential primary determining indication for the formation of certain social and other structures to control all others **who were additionally requested** for some programmed general or private executing processes both in purpose and in the time of implementation on specifically designated territories. Such processes were of conventionally long historical nature and demanded settled forms of organized being. This organized being of people, in turn, was subject to some kind of progressive improvement, which took place in harmony with the level provided by the System of knowledge and development of various technologies **through the individuals with imposed Brain genotypes**. These are those **RESPECTED BY PEOPLE HISTORICAL PERSONALITIES** in all spheres of science, technology of the time, the arts, philosophy, religion and so on. Any **settlement** of such individuals (personalities), as well as their appearance on the "historical scene" at a certain specific time, was not accidental, but controlled. This control was carried out through the Control Complexes, corresponding control servers and was supported by the formation of energy harmony of the private environment through the object energy structures (type 560 and all their subsequent communications of the supporting energy transmitting). The system regulating the controllability of the processes of settlement influenced and directly supported the **necessary quantitative selection of individuals with a specific necessary specialization**, both for the variants of genotypes and for a particular "tribe". For example, lenders, i.e. bankers, were not sent to the reindeers, there was no programmed need. The entire required composition of individuals according to the Brain genotypes **WAS ALWAYS RANKED** in a specific way:

- according to executing control specialization;
- according to the programmed purpose in the planned executing processes;
- according to quantitatively sufficient coverage of the entire required spectrum in the reception of the governing and cognitive information;
- according to the additional coverage of other required features dictated by the private framework of the current Target Vector regarding the going historical chronoprocess.

Such a ranked composition of individuals with the necessary set of the Brain genotypes was mandatory to be in harmony with the program processes of the planned actions and events in a specific designated area. It was this composition of individuals that was the foundation for the formation of some required programmed set of people in a given territorial region. This specialized composition of genotypes, as some defining mandatory basis, required corresponding additional masses of executors who did not possess the indicated Brain genotypes, but met the requirements of a general biological nature defined for this territory and were in harmony with the current program development of energy biogenesis relative to a given locality. All together they, as a definite necessary "Recipe", represented a certain set, i. e., **FUNCTIONALLY HARMONIOUS COLLECTIVE BEING, or community of people**, for which a programmed intended settled organized being was formed with specially allotted territory for them. By the way, all the unexplained so far causal factors of mass people migration processes were associated with this particular feature throughout history. Therefore, the imposed programmed process of the Brain genotypes introduction with their step-by-step development was one of the concealed from people's consciousness first-determining initial signs of the nation formation. This accounts for the fact that during their centuries-long existence, people did not really trust the thoughts and voices in their head. But they learned to believe the voices and hallucinations born in an alien head. The very essence of the interventionist system program "**Energy Information Dialectics of the Brain Genotypes Development**" manifested to our world, not by the will of people and not as a result of a "naturally-logical civilizationally historical process", but by the will from "Outside" such a product -- individuals of Brain genotypes **42-44-46**, as an artificially created level of the only acceptable "executors" for the

interventionist control System. This specially created level of the "executors" was prepared by a certain correction in their Brain construction with the purpose of imparting to some of its functions such special states that could ensure reception and execution of the transmitted system information of a cognitive and controlling character, strictly identified and focused on the formation of the set, individual and social consciousness, execution of only programmed actions and much more "error free program orientation" of all conditions necessary for the organization of actions and subsequent events characterizing those individuals, as if quite reasonable. This fits well with our definition, discussed above – "**Others**". Such a state of the programmed "selectivity" of a separate group of individuals was an act of violence over the very essence of the true purpose of Man on the Earth, imparting him a consumer-goods-like- application state in his whole being. And in this, so called action "from outside" there is no fault of people for all that they did in the past, for **THEY WERE TOO FEEBLE** before such Systems predominance. Where have we come to by this "path", along which we were driven just like a herd, under the control of shepherds?

Nothing like what is happening now, Mankind has never experienced. Before the eyes of one generation an unprecedented track



change of our entire civilization has been realized, moving Man from under the power of natural factors to under the power of factors, artificially created by him equivalents. For example, today radioactivity is more dangerous than flood, and the inability to manage money is worse than the inability to cure a cow. As a result, people began to value each

other and interact with each other, focusing not on primary, natural signs (level of thinking development, memory, attention, ideas, will), but on secondary, artificial signs (money, documents, clothes, housing, "the media", recommendations, licensing). Now all this will have to be "corrected" and improved. ***The new reality CAN NOT BE comprehended today with the help of modern science,*** which was built in the framework of the past processes. Science has to be filled with new directions of its development. Otherwise, it will be impossible to understand and cognize the reality; and to think about what is happening today within the framework of the imposed

scientific paradigm of the past is simply impossible and hopeless, irrespective of by who and what kind of clever words would be used to describe the ongoing events to us, the same as in their time to explain the new reality there came into being **psychoanalysis** – (Z. Freud, "The Interpretation of Dreams", 1900), **behaviorism** – (J. Watson, "Psychology, as a behaviorist sees it", 1913), so-called **Gestalt psychology** (V. Köhler "Physical gestalts at rest and stationary state", 1920), **a systematic approach** of B.G. Ananyev (1968). At that time, they provided the practice of upbringing, education, production, and, most importantly, worldview.

It is necessary to treat the awareness and understanding of the above not from the standpoint of vulgar orthodox materialistic worldview, but from the standpoint of an already accomplished transition to the stage of knowledge of the truth – materialistic idealism.

The methodology and research method first used by A. Khatybov and the founders of the Research Institute of the Center for Preventive Strategies **on the basis of the energy-information dialectics of the step-by-step development of the Brain genotypes and perfection of the control using the Complexes that provide and support Systems and Objects along with the programmed control from outside**, made it possible to show in a **FUNDAMENTALLY DIFFERENT WAY** the objective need to revise the sense and goal hierarchy of all occurred historical processes of the civilization development This is the most important conclusion for those who have taken the path of knowledge today. A fundamentally new research approach allowed us to show the true, but the worst thing for the current state of awareness – **the only use of people as material to be utilized without their will and awareness of the very fact of their programmed application in the past as such**. In this process of insurmountable violence against people, programs and plans of external control were focused on **THEIR SPECIFIC GOAL BORDERS** related to the achievement of a certain controllable level of the Brain genotypes development for **a limited contingent of individuals**. Corresponding to this, a multi-stage plan of energy biogenesis of people's body was implemented with a focus on development and imparting it such complex features and states which were supposed to be harmonious and acceptable for such Brain genotype and corresponded to their further specific plans under the external Control of the Old System.

Man begins to acquire an initiating nature regarding the substance of the true state of the Super Mind in establishing stable harmony with him

within the framework of those true primary functions and the recreated capabilities of his Brain, which are envisaged for him originally as a "Creative" Spirit. People were deprived of the true opportunity to "Create", and as the basic format of values for them, the methodology of "People of value" was laid, which meant imparting them, not in line with their will, a certain price for using them, as some article, but not as not as a being. This is one of the most important conclusions for understanding the happening events. Such was the true essence of what N. Levashov, B. Makov, A. Khatybov, and those, who I mentioned in this book, including the author of these lines, wrote about.

However, we have to go further in our research, relying on new realities and new information, the access to which is becoming available.

5.5. The elements of consciousness in today's Simplicity

Any great idea is absolutely splendid and in the highest degree is useless, until you decide to make it work for you therefore it should be understood some functional peculiarity of the Human Brain activity regarding its mental and thinking aspects, which many experts who call themselves both psychologists and spin doctors have not figured it out so far.

Without deep knowledge of the nature of the ongoing processes for the fulfillment of such important functional capabilities of the Human Brain as mental and thinking activity (naturally, without taking into account corrective programmed interferences on the side of the invaders' System through the formation of 4XX Brain genotypes, since this no longer has any point for them); but only from a model-philosophical point of view, the difference between them should be perceived as processes of a different functional level, harmoniously providing each other with the received information of cognitive and governing characters in the interests of gaining and developing the Mind of people passing to the category of Man. In this regard, I am saying it again, - mental activity is the process of "accumulation" of already formed elements of Consciousness ***in a strictly expressed hierarchy of their significance***, envisaging temporary possible "omissions" in case of lacking of some significant or influential derivatives from them at a specific time of the event. The basic influence on the formation of the essence of such an individual "Logic" (when building up a

hierarchy of the elements of consciousness) is made by functional man's (individual) endowment on the Earth during his being in the physical plane at this stage of the overall chronoprocess developmnt.

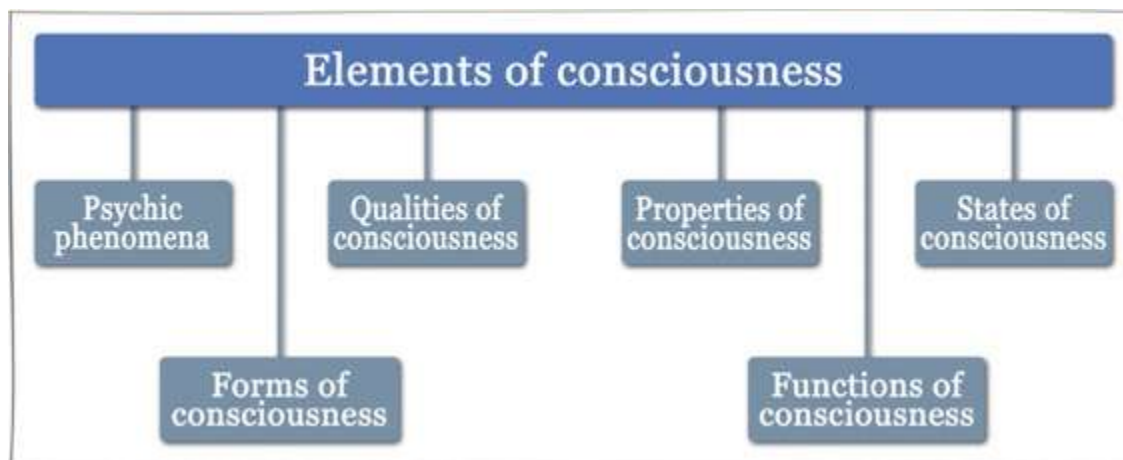

Of course, certain "omissions" of the elements of Consciousness are objective and temporary practically for all people. But for a specific point in the ongoing time, such omissions are expedient for a number of objective reasons. They will be "filled" in the general chain of Logic of the entire hierarchy of accumulation of the elements of Consciousness in the course of acquiring the missing (required) element of Consciousness (in the process of cognition at the mental or segment level) with anticipation before any action or subsequent event fragment of the general chronoprocess, if, of course, as you already know, a certain man **IS PERMITTED DIRECTLY TO TAKE**

PART personally or as a co-participant in some common action. Filling the objective "gaps" for some significant elements of Consciousness (to achieve an individual's Mind development) can be stretched in time quite significantly and executed in two or more stages of the so-called the Investment that was Shown in the material world, i.e., not within one



"life" in the form of the physical plane of the Spirit's being. However, I will certainly note here that the use of the "**SvetL**" **Programs** in these processes very much corrects everything that I said above. For this purpose they were created and are being perfected constantly, depending on the events happening and the man applying these programs, because his philosophy is

his vision of the Universe, by which he is guided in everyday life. It is unlikely that they can be found in the textbooks.

The "SvetL" Programs' help here, if man consciously applies them, as already shown by many years of experience, is very useful and effective. And let those few spiteful critics and "experts" deny this in every way, throwing mud at me and the people involved in the distribution of these Programs – ***this is absolutely not important and insignificant***. No need to look back at it and take it for the truthful information. ***Today, no one has any arguments against it***, because there is a real numerous experience of people using them. ***Everything else is not only secondary, but does not deserve any explanation***. I realized a long time ago that not a single man is able to do anything that is **NOT CHARACTERISTIC OF WHAT HE IS**. But if there are no positive consequences of the corrections made for everyone by the New System, then such an individual will be saved from, usually in a natural way. Actually, this will happen with all spiteful critics – I am just sure of it. And some of them have already got their due. Here, of course, no Programs could help. For the Spirit in such cases, the correction of the further functional endowment of the Investment that was Shown in the new physical plane can also be imposed. Well, what for are the people in the future, like those who live in the present day with lies and hatred, envy and spitefulness? What for are those who write, for example, articles and books about gravity, not understanding anything in it, or so-called "books" like "Special Operation "Ringing cedars of Russia", etc.? They will get their due for mistakes, lack of will and other disgraces, and this is not from the point of view of any kind of intimidation, including religious one. When everything is primarily based on lies, then the result will be appropriate. We punish ourselves much more than anyone or anything. True, few people understand this today. Each of us is one's own judge! This is becoming more than obvious. Mental activity in individuals of Brain genotype **4XX** is in auto-motor-like-way condition and was directly dependent on the external control of the Old System. The very Logic of building the hierarchy of accumulation of the elements of Consciousness is simplified by their functional endowment (depending on the genotype type). The accumulation of the elements of Consciousness was strictly filtered and carried out precisely in the quantity and in the direction of specialization in which the individual was involved through the implementation of his intended executing activities. This is something like a "simplified arithmetic in pictures and blocks".

What is very important now and why I touched on simplified thinking about the mental and thinking activity of the Brain? The fact is that in the process of mental activity one has to initiate for oneself **ANY GREAT AMOUNT OF QUESTIONS** concerning the subject of one's thoughts, especially in the urge to know. It is in this way that you energetically activate the previously hidden capabilities of your Brain functions, not train (these are not muscles), **but draw His attention to His state**. "Another one will not be given until this has acquired the necessary activity and realized His capabilities". It is hard to understand, but it is necessary to move further in the chosen direction, comprehending the truth of the ongoing.

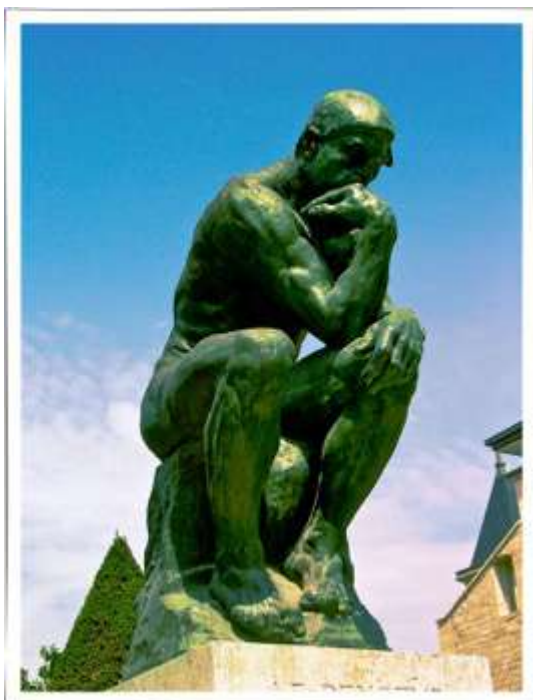

Nowadays (in the process of some information coming out and, especially, from the media) people have a lot questions of minor importance, such as: about B. Berezovsky and his "deeds" (including dispersion of his Brain for ever and ever without a chance for the Shown Investment, that is, passing away forever), about the so-called Government and its activities that affect our life. About the events of a "clinical" nature in England, about the appearance of encephalitic ticks in some areas (where Winter with the Snow Maiden triumphs), emerging dips of regular round shape and much more. In the end, these are the processes of the elimination of the old Construction of the organized being, **the humiliated being of the majority**, over which a small minority parasitized! While regarding everything that is happening exactly from these positions, then the questions you have will turn into the awareness of the confirmation of all this. Every event that is taking place today is objective: the point is not what it means; the point is what it means to you. This is the easiest recipe for today, and we will certainly accept it, but we will approach Simplicity parting with it. It will be correct for my readers in all respects. I really hope for this. And, may Happiness come then?

5.6. It maybe definitely, but by no means finally

The category of "Happiness", which is not yet taken into account in our everyday life, as well as in our domestic policy, in my opinion, is the final, concluding, integral measure of the state of Man. And it is precisely the happiness of Man the new political reality is modernizing through the replacement of the ways of achieving it.

I did not use the category of "happiness", which in our perception and in domestic psychology has not taken so far, a worthy place; although I could see that it was this category that was an integral measure of the human capital quality. And it is the happiness of Man through the replacement of ways to achieve it the Old Control System modernized in the process of globalization. Again and again I turned to many sources, including the respected authors mentioned in this book, and found in N. Levashov's and in the materials of A. Khatybov and the scientific research institute of the CPS that they considered the category of happiness to be **THE FINAL PSYCHOLOGICAL INDICATOR OF MAN'S DEVELOPMENT**. This allows me to mention the happiness of man as a key criterion for the quality of human capital, as defined by A. I. Yuryev. And mainly – to show how happiness grows from the daily routine practice of people. Or rather, it began "growing" intensively recently before our eyes (if the eyes are open, of course), although many people do not think of it, do not talk, but this determines their real behavior and the situation in our country and not only, and the country itself. I'd probably not surprise anyone today, but according to the **UNDP** (United Nations Development Program, 2004), by the human development index, **Russia ranks 57th in the world**, far behind Norway, Sweden and Australia, Canada and the Netherlands and being just below Cuba, Mexico, Bulgaria. It is hard to believe it (quite recently, Russia had the best in the world education, culture, arts), if you do not know what the Control System is (the Old System), which, through globalization, laid quite new claims to people and their human capital, which are not taken into account in the process by anyone and anywhere due to misunderstanding of what is happening, and considering only in comparison "what it was and what has become".

Nobody has ever thought about the fact that, with the beginning of the so-called "globalization time", the shaping of man was according to a completely "new" social project, a new educational technology and for completely new political and economic conditions. But all this began to occur

precisely at the last stage of the Brain genotype development as part of the so-called "golden billion", creation and even more so of the "golden million", and these conditions radically changed every four or five years, beginning in the fifties of the last century. And to understand the social changes, educational technologies, through which you can influence the happening events, there is a need in a psychological theory that is adequate to global changes in the world and the country which has just begun to emerge in people's heads. Those people who are part of the preserved indestructible potential of a multinational indigenous people (here we mean the territory of Russia), the so-called **Human Potential**, and not **capital** in all the "theories" created within the framework (it is of no importance whether their authors wanted it or not) of the ongoing capitalist violence, which today is more in line with the framework of the new systems endowment of Russia and all its indigenous peoples. I do not in any way mean to offend my friend A. I. Yuryev, who for the first time in the world introduced this term (Human capital) into circulation and clearly explained this concept in his writings, but this had been done in the period before 2012, and you, readers, now know what I mean. But let's go back to that not distant time.

So, **Human Capital** is the main prize of the global battles organized within the Target Vector of the Old Control System – the final result of all political, economic and social efforts of the state. The state is a "plant for the production of human capital", which was designed, calculated, created by a technology no less strict than financial capital. The quality mark of human capital produced by the state is the level of people's happiness. Unhappy people are not reproduced, trained, brought up, defend their country, and produce competitive products. But it is hard to discuss the problem of human happiness against the background of what is happening – only at the threshold experienced cynics belatedly understand that they have missed the most important thing they had been laughing at. But still – not all of them. Most convicted for life criminals begin to read the Bible in their cells and only there as it seems to them they find where the great mystery of life lies. We will not condemn them for this, and even less – discuss this rightness. There are protocols of psychological interviews with people about happiness, **WHO KNEW THAT THEIR LIFE WAS ENDING. Only on the threshold all of them, who used to be strong winners, admitted that they had wanted to be happy, but they had made a mistake when choosing the way to their happiness.** I want to draw your attention to the fact that this is what most clearly expressed today by those

who still imagine themselves to be "rulers". But we should least of all care about it today. The great philosophers were right when saying that ***happiness is like the house for a drunk: only he does not remember how to get there.*** Unknowing the sense of happiness for man is worse than unknowing the traffic rules for a driver. At all times of his existence, man has been tormented by the same question: ***what does He live for and what is his role in the general structure of the universe?*** He has not yet found the answer to this question. And he was not supposed to find the answer under those conditions he found himself not by his own will and wish. Human development took place through trial and error of many false theories and principles. At the same time, the best minds put forward unique, but underestimated principles of development that could only be implemented in the future. As I have repeatedly mentioned Humanity has entered a fundamentally new phase of its development. His mission is determined from above, and all his activities are governed and directed by the System through the New Programs. Under the new conditions, in conditions of the whole man's life harmonization, the state, for example, **CAN NOT EXIST** in our usual perception. New approaches are required that are in line with the New System Programs. They are already showing up as sprouts making their way through cracks in asphalt, cracks that are getting bigger and deeper. The main subsystems of Mankind will be preserved only in their names, namely: a state or political system (Structural power); value – integrative system; culture; economy. But their functions and the substantive part are different significantly in their true nature, and this is the will of the New Program, which no one can cancel.

For the true man who is freed from the former captive state of the programmed processes of the old System, the main thing in his world outlook is ***the awareness of his truly recreated mission on the Earth***, a deep understanding of his personal functions and his mandatory and **MAXIMUM POSSIBLE EFFICIENCY** of his very existence for others equal to him. That is, this is a question of Happiness, the sense of life of the recreated man under new conditions of states and processes, including being correctly knowledgeable in his development, harmonized with the general changes of the Earth model as a whole. And then the integral indicator of human potential is the **MEASURE OF HAPPINESS OF MAN**, which is revealed in ***the fullness of being experience*** related to his self-realization. In other words, **MAN IS PERFECTLY HAPPY** if ***all 16*** (known today) ***variables of his psyche*** are self-realized: thinking, will,

abilities, temperament, character, gender, age characteristics, speech, etc. Against the current background of the ongoing transformations, an indicator of self-realization is recognition, acceptance, and application of man's achievements in professional, public, personal life. Then the "products" of man's mind, his will, character in the form of inventions, works, achievements in labor, personal relationships acquire consumer's value: they are bought, accepted as a gift, they are used, and they are thanked for. Man is happy – he is understood, accepted, recognized.

But **MAN IS UNHAPPY**, if because of some inner or outer reasons he cannot be self-realized. Inner causes are the lack of content that must be self-realized (he is not educated, not brought up, inept, inactive) or some inner psychological barriers that prevent from self-realization: shyness, modesty, inadequate behavior. Outer causes: society's non-recognition of man's achievements, for example, refusal of work, publishing, and love. Or it is a direct ban on self-realization, for example, imprisonment, exile. But most importantly, he does not create his own reality. He creates his own illusions. Politics, depending on its goals, either facilitates or hinders the self-realization of individual human properties (neurodynamics, sex, age characteristics, and physical build), subjective characteristics (will, thought, affect, and perception), personal characteristics (direction, ability, temperament, and character), individual attributes (experience, individual story, productivity, uniqueness). For example, the policy of making people miserable, declaring war, that is, closing self-realization in relationships with loved ones, the implementation of fascinating ideas. Or punishes a guilty man with imprisonment, actually condemning him to "the impossibility of self-realization", that is, "reducing the experience of the being fullness", that is, "unhappiness". But politics, expanding personal, economic, political freedoms, can create conditions for the self-realization of man of such magnitude that he experiences the rising of the fullness of his being, that is, happiness. It can, but for some reason this is not happening today. ***The dominating factor is – Live as you want, and pay the required price for this, no matter how much it is.***

Political power in its previous embodiment was and still remains in people's perception the main source of social injustice generation, no matter what slogans it uses as a cover. There will be no more parties, the acquisition of a parasitic special social position by an unrecognized way will be considered and recognized as a special crime against the entire social organization – Mankind. The exclusion of political power is carried out

through the introduction of the social subsystem – Unstructured (Public) power. The recognition of the highest social position of each Man and his gaining the right to represent all of Mankind in the Unstructured power is the highest reward and appreciation of Man's being.

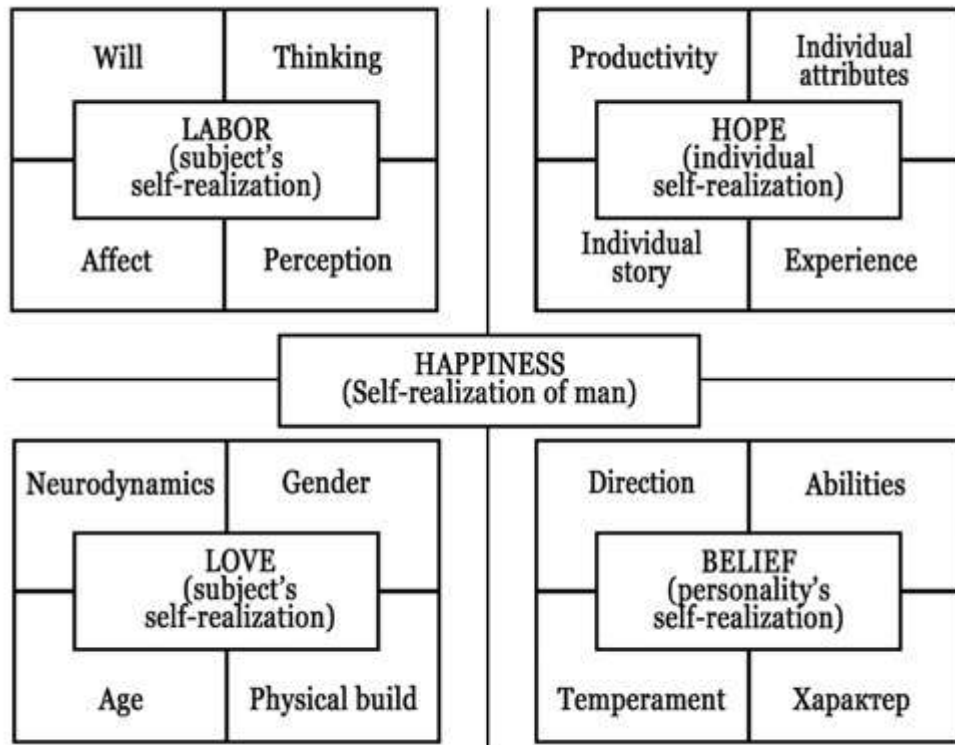

Microstructural psychological description of happiness as an integral psychological indicator of the human capital quality

THE CATEGORY OF HAPPINESS, unfortunately, is a little studied psychological reality. The main meaning of happiness is that it plays the role of an accumulator, which gives a "spark" for activity and work (but not labor), provides what is called "the rise of vital and creative forces". **UNHAPPINESS** makes man vulnerable to illness, mental abnormalities, ousting of society and life. The experience of happiness, even short and rare, charges the psychological "accumulator" that triggers off the vitality of Man. And the one whose vitality is undermined from the very beginning, no medicine in the world can prolong the life.

5.7. An integral indicator of the effective

Happiness is a hard attainable experience. Very few have experienced it and therefore deny such an experience. "Only strong people

are given happiness... " – we read in many books. It can be felt only at the moment of the highest tension of all human forces in labor, in battle, in search of truth, in intimate life. Happiness is a phenomenon that rises at the moment of the utmost tension of the mind, muscles, will, and patience. He who avoids the utmost tension never experiences happiness. Moreover, a sign of happiness is the readiness for suffering and compassion, which contradicts a faulty understanding of it as "the feeling of highest satisfaction with something". Only a happy man is ready to sacrifice his life, to endure unbearable pain for the sake of the source of his happiness. All discoveries, all heroic deeds were made by happy people: Jan Hus and Nikolas Copernicus went to the fire for the truth revealed to them. Parents give their lives to defend their children. There are a great number of examples. Probably, that was what I. S. Turgenev meant when he wrote: "Do you want to be happy? Learn to suffer first". Although today you may not agree with this! The way to happiness through suffering is from that past of which we, readers, already know a lot. Today we live in a world where funerals are more important than the dead man, where wedding is more important than love, where appearance is more important than mind. We live in a packaging culture that despises the content. Against this background, it seems to us that suffering and happiness are located in the opposite parts of the world. Life seems to be the road between them. But this is wrong, because, in fact, **THEY ARE TWO DIFFERENT ROADS**. One leads to happiness, the other – to suffering. And each man chooses his own road, chooses the way he has to go.

It is known that happiness cannot be possessed, ***it is a mandatory thing to be handed over, and no other purpose does it have***. Man is happy only at that moment when he "hands over" his feeling of happiness to another man. A happy man always regrets that someone else cannot share with him the pleasures of contemplating the landscape, the height of the heavens, the view of the depths of the ocean, the penetration into the mystery of nature, the delight of duel winning, and so forth. Man overjoyed with happiness immediately loses it if there is no one to share it. The poet M. Svetlov said: "***And if not joy and happiness, then what else could I give people?***"

Many people know that happiness, turned into pleasure, loses its meaning and strength. Happiness always rises, not because one strives for it, but because it is a natural result of the utmost effort for the sake of someone. Stanislav de Boufle also wrote ***that pleasure is the happiness of fools***,

happiness is the pleasure of the wise. L. Seneca says that the more you strive for happiness, the more you move away from it. K. Balmont writes "they were looking for happiness, they did not find happiness". O. Huxley says that happiness comes out like a by-product, like coke in the production of metal. B. Spinoza things that happiness is not a reward for virtue, but the virtue itself. But, finally, at that level of the Brain genotype development it was made clear that happiness was unattainable or short-term. In my opinion, this microstructural psychological description of happiness, as an integral psychological indicator of the quality of human capital, is fully consistent with one of the undeservedly forgotten principle – the principle of Harmony. It is this principle of development that should be laid at the present stage of the life of Mankind. Harmony (Greek. ***Harmonia*** – connection, balance, proportion) – the parts and the whole proportionality, the merging of the various components of an object into a single organic whole. So, what kind of Harmony can we talk about in relation to man? The question is absolutely not idle, since the correct idea of this concept determines the choice of the general strategy of behavior and development of the entire Humanity.

Firstly, the question is about the inner harmony of an individual, especially Man of the Future. It can be described as the ratio of his desires and his capabilities and, as a result, the degree and the depth of his self-realization as a personality among others equal to him.

Secondly, harmony of interests of an individual and human society within any social structure of any level, up to the future of Mankind. It can be expressed as an optimal combination of his maximum usefulness for all and everyone.

Thirdly, harmony of common human interests, i.e., large-scale optimization at the level of interstates relations based on common interests and values, followed by a transition into a single global community without any hegemony of one over all, and this is extremely important today.

Fourthly, harmony between man and nature. Man must consciously deny himself the role of the "king of nature" and consciously recognize himself as its keeper and protector.

And, finally, the Humanity's entry into cosmic unity, no matter how pathetic it may sound.



The above signs can be considered to be basic ones in achieving happiness with the further development of Humanity. Of course, next to this it is necessary to consider and implement other harmonies, such as interethnic and interconfessional and others. But altogether, they will certainly create all the necessary conditions promoting the natural fullness of happiness. And, naturally, the category of “happiness” will deservedly become one of the psychological indicators of human development and will take a worthy place, being an integral measure of the quality of human potential, of course.

Strictly speaking, happiness is an integral indicator of the effective state of Man, which **IS FORMED BY FOUR DIFFERENTIAL EXPERIENCES:**

- a) an individual – when he loves;
- b) a subject – when he creates consumer value by his work;
- c) a personality – when he believes in the true strategy of his life;
- d) an individuality – when he finds hope achieved through suffering in the picture of the world.

That is why today, against the background of all global changes and transformations, politics, or rather, those who imagined they had the global control of everything and everyone, – manipulate the experience of happiness not directly, but indirectly, by heightening love or hate (a generalized indicator of self-realization of an individual), through the opportunity to work or deprivation of work (a generalized indicator of self-realization of a subject), through strengthening people's faith in man and society or its destruction (a generalized indicator of self-realization of a personality), self-realization of a personality through the formation of hope

for a better future, or its destruction (a generalized indicator of self-realization). This is a very striking indicator of their “auto-motor-like way” of thinking and making decisions which they are trying to translate into the realities of today! But it does not work! It makes them furious. But why it does not work – neither they, nor their "court" political scientists, sociologists and other spongers – are not able to understand.

5.8. On love and harmony

So what should be happiness like in our time? And in general – is it possible today? Happiness is an integral indicator of the state of man, and **it is conditioned upon the four its components**. Some other components may appear, which is quite objective in the development of the ongoing changes, but they are not known to me yet.

About the first one – as far back as V. G. Leibniz said that **love** is a tendency to find pleasure in the weal, perfection, happiness of another Man. Or the tendency to combine the weal of another Man with our own weal. In his letters, he wrote: “To be fair is to be merciful, but so that it is consistent with wisdom. Wisdom is the knowledge of the highest good. Mercy is an all embracing favorable disposition. Favorable disposition is a habit to love.” This was said in **1699**. Understanding the meaning of such a statement is an exam question for all readers, and not only – **So, what is love?!**

Let's remember (those who have read), and for those who have not read the book of Nicolai, I will make an excerpt – it will be useful⁶⁵ for everyone. Practically, he is the only one who through the prism of New Knowledge gave us an explanation of the feeling of love through the revelation of the nature of emotions (especially the higher emotions of man), their role in the evolution of life. He could not ignore this question, because emotions, feelings, excitement, suffering, inspiration and disappointment, love and jealousy, sublimity and hopelessness and many other manifestations of our soul fill our lives from the first cry with which we come into this world, and to the last breath, with which we leave it. We already know that in humans, favorable emotions enhance the Brain development which leads **to further spiritual evolution of Man**. With this, the

⁶⁵ N. Levashov “The Mind and the Spirit”.

degree to which every single individual goes through such stages is **manifested in the qualitative structure of his Spirit**. Therefore, the relationships between man and woman involve not only external beauty of the physical body, but **also the inner beauty and richness of the soul**. The outer beauty serves as a stimulus for a physical intimacy between man and woman, while **the inner spiritual beauty is the mainstay** and support of the relationship. The anatomy of love is not blasphemy, as some may think, but a necessity that can help us understand ourselves more deeply and, perhaps, steer clear of negative behavior – gaining greater happiness for ourselves and for our loved ones. Let us recall that the qualitative level of one's development manifests **in the qualitative structure of one's spirit**. Therefore, the interaction between man and woman manifests primarily at the level of their **spirits**. At the same time, it is necessary to point out that a male and female spirits **EACH HAS ITS OWN DISTINCTIVE QUALITIES** and, that when complete harmony prevails, they complement each other and together they constitute one **single system**. With full harmony, there is an active interchange of qualities between them. The man receives from the woman certain qualities that are lacking in the qualitative structure of the male spirit, but he needs for his further development.

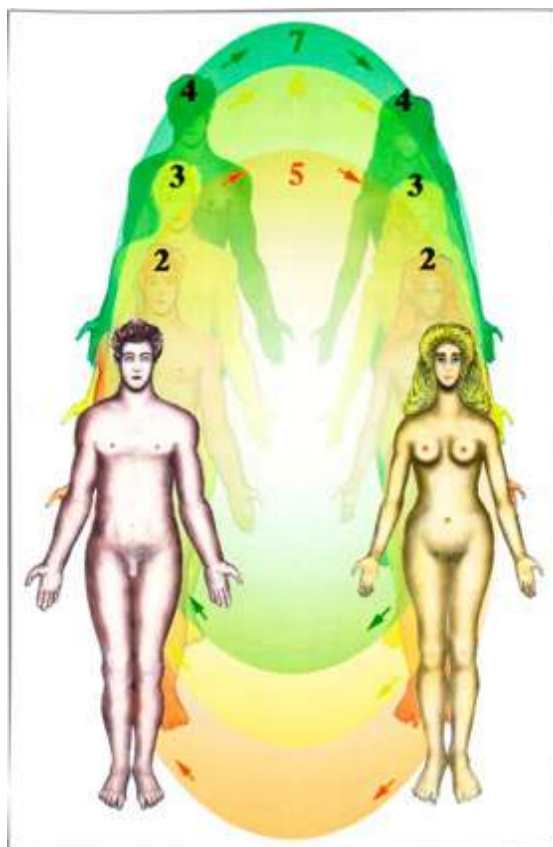

Full harmony between man and woman.

In turn, the woman receives analogous qualities from the man, which she does not have and cannot have due to the qualitative structure of the female spirit, but without which her further development is impossible. In a state of harmony, man and woman complement each other as two halves of one single, and at the same time between their spirits at all levels there is an active interchange of qualities, which is accompanied by that ineffable feeling called **love**.

We remember that the level of evolutionary development of each individual manifests in the qualitative structure of his spirit. And this, in turn, means what types of spiritual bodies evolved and what level of their dimensionality they have.

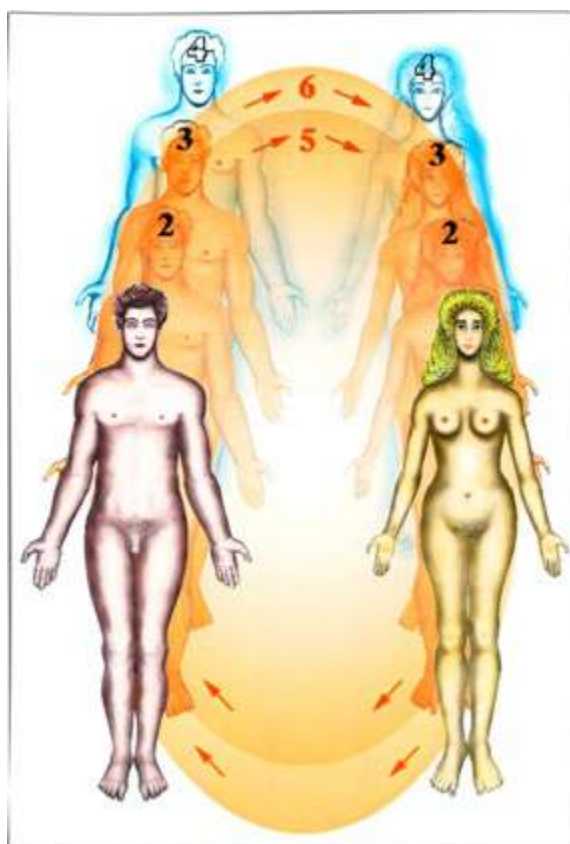

We may speak of complete harmony between a man and a woman only when the dimensionality levels of their constituent spirits possess identical or very similar values. For this reason, harmony may arise between man and woman even when each is at a different stage of evolution. Such harmony may be temporary or permanent. Usually, it is temporary if they have not completed formation of their own developmental course (as in the figure above).

The state of harmony in this case is determined by the fact that their evolutionary development intersects at a certain point and both are in sight

of each other. s can be relative to each other in different ratios. When a particular man meets a particular woman the level of their spirits development may be different. One of the two may have a more developed spirit, then a deep feeling of love between them is simply not possible, if there arise some relationships, then they are rather superficial and short-lived.

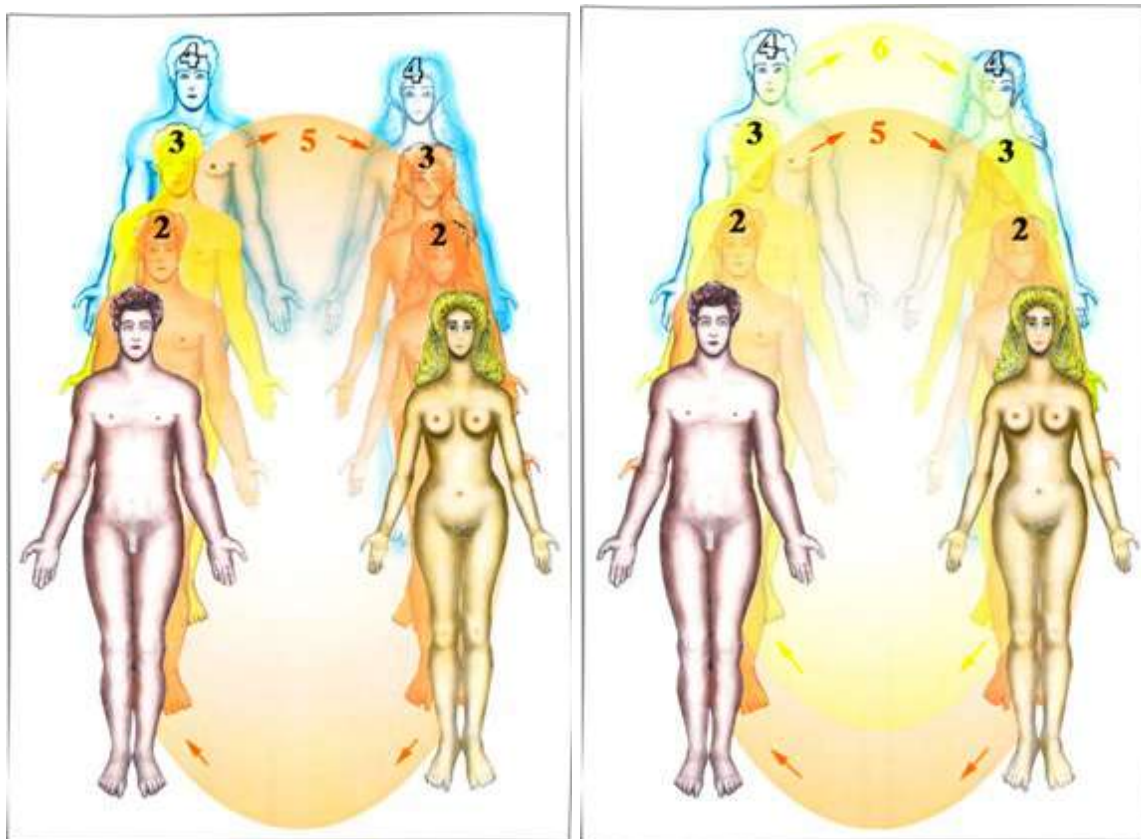

Similar levels of evolutionary development manifest in shared interests, aspirations, and dreams, which, in turn, engender mutual understanding and support. Therefore, when two people are that close to each other spiritually, and their souls so much attuned to each other that love can develop. This becomes possible because at all levels of their development, they enjoy full harmony, which is manifested in the close or identical levels of their spirits's constituent bodies.

People keep developing and changing over the years and it often happens that a loving couple, who initially were really close having deep feelings, gradually begins move apart to such an extent as **TO LOOSEN THE BOND BETWEEN THEM**. Then even the closest relationship brings only irritation and hostility. So why does that magical feeling called love *"fades away" for some people, vanishing in the sieve of time*, turning into a mirage while for others love follows them all their life filling all their days with radiance and warmth and enriching them spiritually? What is that mysterious thing called love? Why is this mystery is revealed to

some and forever veiled for others? Or maybe the angel of heaven passes her secret to the favored few? And if so, for what deeds the Lord God rewards the lucky ones?! Why does love sometimes dwell in a humble home, suffusing it with warmth and light while eluding the palaces of the wealthy, leaving them cold and empty ?! Or, why does it sometimes flash like a bright star, and vanish imperceptibly, like a morning fog under a rising sun.

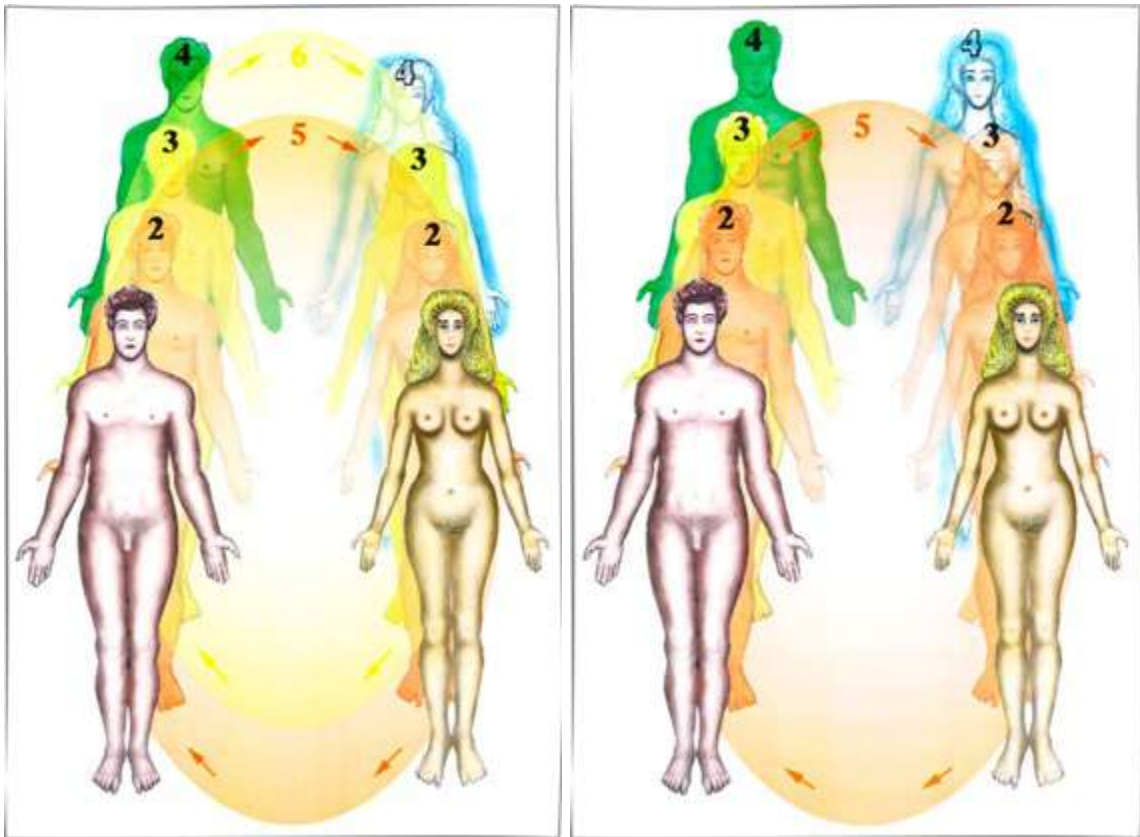

Where is that key to this mystery hidden, ***that has confounded Man since Adam and Eve ?!*** Love is a harmony of the souls and it vanishes when that **HARMONY FADES**. The latter occurs when the partners undergo qualitative changes in the course of their evolution. Then one of them may surpass the other, bringing to the disappearance of primary matter circulation on one of their spiritual bodies; spiritual levels of man and woman (see the fig. above).

In this case, someone turns out to be evolutionarily ahead of the other and, as a result, the circulation of primary matters between the bodies of the spirits of man and woman at one of the levels disappears (picture above).

If this process continues, then at a certain moment there will be nothing binding these two people. Because of qualitative differences in development of their spirits, there remains only a sexual contact without any spiritual harmony (picture above). Due to the fact that ***during sexual***

contact there is an energy exchange between the partners, it is very often that this contact brings nothing but irritation and enmity. This is because the discrepancies in spiritual development also give rise to qualitative differences in the energy flows exchange. The latter being incompatible, their confluence provokes negative emotions only, since they merge at the qualitative level of the partner having a lower evolutionary level. And the incompatibility of the flow with the partner's qualitative structure evokes a protective emotional reaction of a negative nature. This renders the intimacy undesirable for at least one of the sexual partners.

It is similar to a feeling of aversion when food tastes bad; our taste receptors are warning us against ingesting a noxious substance. Similarly, a negative emotional reaction during the sexual act between a qualitatively mismatched people, signals the subconscious about the incompatibility of their spiritual structures. With harmony between man and woman, their spirits, which are of opposite polarity, start triggering the flow of primary matters within the closed system they have created. Difference in polarity between male and female spirits is determined by the qualitative difference in their structures. This qualitative difference manifests in the fact that in the **male spirit** primary matters flow from **the coccyx to the head**, while in **the female spirit** they move in the opposite direction – **from head to coccyx**. Similar processes are observed at the atomic level, when electrons having positive and negative spins (which is also manifested in the antithetical movement of primary matters), create electron pairs, which are stable systems.

Electronic pairs – married couples – are identical phenomena, **reflecting the harmonious condition at different evolutionary levels of matter development...** In the fully harmonious couple, the flows of primary matters passing through the male spirit's structure, also flows through the structures of the female spirit, causing additional saturation of the female spirit's bodies. And, similarly, the flow of matter passing through the structures of the female spirit additionally saturates the bodies of the male spirit. Thus, with harmony between a man and a woman, called love, both receive additional potential from each other. Likewise, there is exchange of male and female qualities in the process, without which the evolutionary development of each is impossible. In order to advance to the next evolutionary stage, it is necessary to have the qualities of both male and female. **That is exactly what happens during the intimacy of**

lovers and is called "white tantra"⁶⁶. This is only possible between the two, when there is a full harmony and mutual love between man and woman.

Tantra is a "thread" translated from Sanskrit. Areadna Thread, if refer to the Cretan story of the labyrinth of the Minotaur. It is no coincidence that Ivan Efremov often turned to this image in his work. The Andromeda Nebula is the name of a starship drawn by an iron star, and the meaning of the whole book can be described as the cosmic conception of a new Humanity.

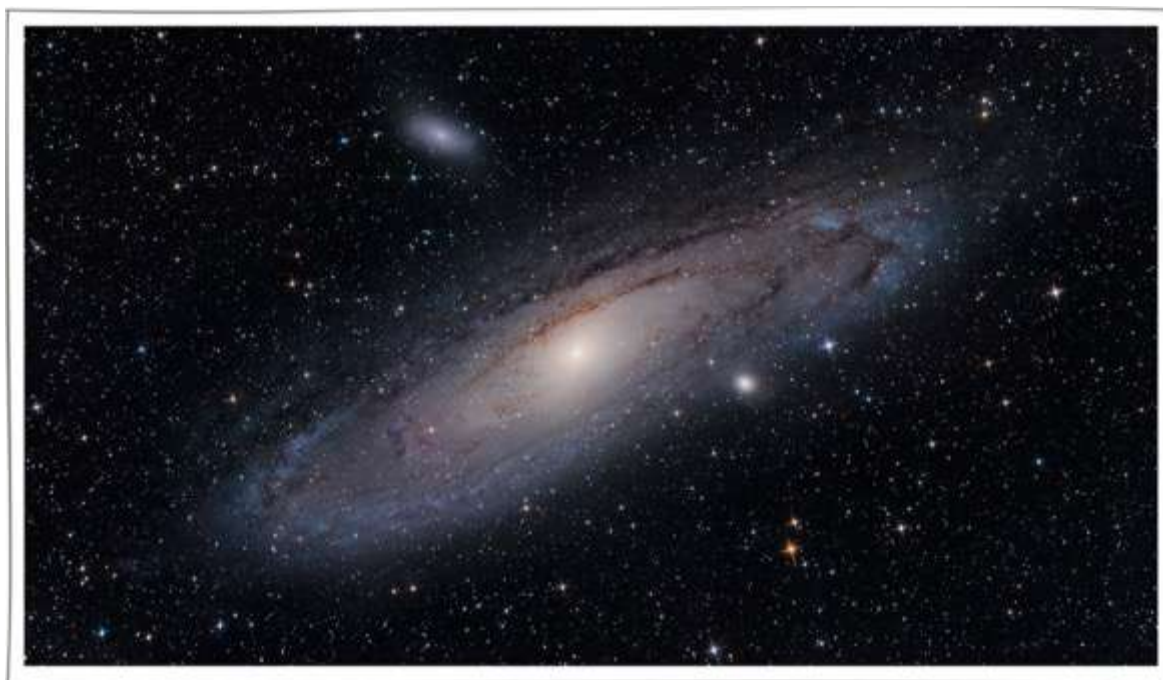

In the light of harmonization of the married couple at all levels, you can logically describe the mechanism of the energy splash at the moment of conception, which is able to attract the most highly developed Spirit to its birth in a new physical shirt. Let's consider the ideal option when harmonizing married couple's spirits at 7 material levels (which corresponds to the level of the Brain development $2^7 =$ octave 128), it is not for nothing that the number 7 has the meaning of a seed and family in Russian. At the moment of conception, according to the law of Octave (also known as the law of 9), the next 8th stage of the system evolution is initiated – the fetus formation based on the male and female origin identity, similar to the origin of a new star in the area of heterogeneity of the Universe. A mandatory condition for this mystery is the energy information support from above in qualitative resonance with the parents' potential, creating an energy splash,

⁶⁶ H. Levashov's terminology from the book "The Mind and the Spirit".

synergy. At that moment, when a single fertilized zygote begins to divide (which is figuratively read in the figure of eight), the macrosystem of a two-person family enters a three-person phase.

The fetus is being born for 9 months, and this figure is not accidental, its image is read as germinated seed. In line with the systems evolution law, at the moment of birth the whole system goes through a zero-passage, $9 \Rightarrow 0 \Rightarrow 11$. A physical meaning of the zero-passage is the fetus transition through the birth channel and a new personality show to the world. A new – born child at this moment is experiencing a change of dimension, moving from an old reality to a new cosmos. And the next phase of development naturally goes through 8 stages ending with another zero-passage 9–11 (development of the astral body, sexual maturity, etc., by octave). The fetus, crossing the border of the qualitative transition, dying in an old space of existence, is simultaneously born in a new space. Thus, the condition is fulfilled – "**Death is conquered by death**", once again proving that there is no death as such, but there is a qualitative transition, a change of dimension.

Are not the desired children the highest value and a component of the happiness of the Family, the Clan, the People, the Nation? The future of Russia is a Multi-People Mono-Nation, whose main goal is the happiness of Man, and this means, first of all, children and their well-being.

However, such a phenomenon is quite rare, since not everyone is able to find his "half", and many do not try to look for one, following the saying "a bird in the hand is better than a crane in the sky". Few people take a dare to wait or look for their intended over distant lands, in the far-off country and go through fire, water and copper pipes...

And in conclusion I'll not fail to add that if someone of the readers doesn't understand something in this text or pictures, do not hesitate to look for the book "**The Spirit and the Mind**" by N. Levashov and read, finding all the answers to the questions.

The second component of happiness is faith (self-realization of a personality). This is an extraordinary phenomenon, because Man lives only until the moment (!) **WHEN HE BELIEVES IN SOMETHING**: in another Man, in an idea, in circumstances, fate, etc. The destruction of his belief in the first, second, third is like a parachute shrouds break, man's loss of links with life. In order to live, strive, fight, it is sufficient for Man to believe in a few worldly values: **2, 3, 4...** "**Personality**" in psychology is

a social suit, put on the "skeleton and muscles" of Man's faith.

Man is recognized as a personality not by clothes, but by a confident build, the dynamics of movement, which is given to him by faith, which determines the strength and impact of his personality. It is faith that supports every word, movement, and act of a personality.

It happened "as if by nature" so (and you already know why) that people **CAN NOT LIVE WITHOUT FAITH**, because they are not just some creature acting as an animal by the instincts, and not just a receptacle of some intelligent reason. There is something in them so mysterious, extremely many-sided, that it is beyond their control, but it pushes them to a constant search for some kind of perfection. Their inner world must inevitably include intuition, a certain developed feeling of belief in something – in God, cosmic wisdom, in good, in salvation, in happiness, in destiny, in success of something or in something.. ***Man is able to give up his faith and move away from it, but immediately gain faith in another sphere.*** There is one thing Man is refused- for some inexplicable and independent of him reason (as the overwhelming majority of us thinks today) he cannot be, that is, live without faith.

Faith is of personal nature, as it expresses the whole of personality, and not its individual aspects. It is manifested in a strained way nowadays, in the face of changes in everything. This attitude can be characterized as selective, since it is related to the significance of something, and if specifically, changes in the life support processes for people. The construction of a subjective reality today especially requires regulation of people's life activity in accordance with it, and faith acts as a **MEDIATED WITH SPECIFIC MOTIVES INCENTIVE** of such activity. The whole range of thematic definitions associated with psychological research, scientific studies of the past, reveals a lot about the inner world of people, but never deals with the problems related to finding the true outcome of the process from the inception of faith to gaining its stable effective state and its further decline. i.e. reduction of its functionality, leading to frustration or dissuasion. How such complex states of faith are formed, in what way with their help the process of individual executing actions is stimulated, and how it affects the level of awareness of the environment objective reality, leading either to scientific deduction, or to control stimulation of subsequent actions? No scientific or psychological research can give answers to such questions, since all their scientific world comprehension is based on the collected analysis of individual behavioral superficial results, and they fail to look into the "Soul",

as they say, so far they have not been able to find it. Today you can look into the "Soul" and "talk" to the Soul only by applying **the "SvetL" Programs** and only under the condition that with the help of these Programs the Soul itself looks into itself and puts everything in order within itself. More so, in the present period, **the whole basis of the programmed basic process of the control has been changed**, people have not fully been aware of this yet, but this state will be perceived as soon as the process of changing and correcting functions of People's Brain is completed and the control information translation begins, including the sphere of knowledge, resulting in **ANOTHER STATE OF FAITH GAINING**. Because faith without knowledge is dead. And faith is not born from the actions of man, on the contrary – faith dictates actions. My faith is in the progress of a new science through New Knowledge of new technologies, which we cannot even imagine today will bring people happiness. We already have the beginning – I know what I am talking about. It will be exactly like this – I am sure of it.

Despite all the centuries-old pretentious statements about the greatness of Man, his omnipotence as "the conqueror of nature and his exclusive subjective independence of nature's phenomenon", it is necessary, first of all, to provide him with the true knowledge and facts giving light to the technical and technological aspects of the Control process related to the programmed state of faith changing. This is what I am trying to do through my books. How well I manage it – is to the readers to appreciate. The faith itself has to be perceived as the governing Program, as special programmed state acquired along with the functional endowment of each individual at the birth of the Brain. It is faith, as a programmed predestination, that does not make it possible for the Brain function to be in systemic "error".



Before touching upon the change in the state of faith, it is necessary to reorient the previous perception of the "sense" of something definition, since its former philosophical concepts in relation to only the sensual and behavioral level **ARE NOT ACCEPTABLE ANY MORE**. Within the framework of the concept of faith, it is extremely important not to forget about ***the functional state of "Sense"***. This is the determinant of achieving the level of harmony between the controlled structures: on the one hand, the acquired information in its new construction and, on the other hand, the construction of the true DNA model of the Brain cells and the modified construction of the Brain information block of higher octaves. Otherwise, ***the sense*** is such a level of minimal deviation from the harmony of these controlled structures, at which the information received by man after its decoding **CAN BE FURTHER ACCEPTED** for all subsequent step-by-step application, moreover, **REGARDLESS OF WHETHER it is of a controlling or cognitive character**. If the received information cannot be further used by an individual, then it does not have a true meaning for him, and therefore, as unacceptable, ***is eliminated in the information block of his perfect Brain***. But this natural essence is not a random process, since for the expression of the subjective uniqueness of each individual, even with a certain limitation of the old System, a functional endowment was given to each individual through the **UNIQUE FOR HIM DNA construction at the birth of the Brain**. This uniqueness of the Brain under the conditions of the new Control System, i.e., when the Brain acquires a higher level of octaves, **PROVIDES FOR** the possibility of constructive harmony **IN FUTURE OF ITS DEVELOPMENT** the possibility of constructive harmony. But this, unfortunately, will be in the future. And what about today? And today, only the "***SvetL***" ***Programs*** will push in this direction, but, believe me, not everyone. However, if there is faith based on knowledge, there is a real chance, including healing, of course. And there are examples of this, based on experience of application. It is this fact of a different approach to giving each individual a unique functional mission that completely excludes the process of using man as a thing to be thrown away in the future and makes him an active participant in all executive processes of evolution. An individual from the category of "people" transforms into the category of "Man" and begins to acquire the corresponding true meaning of his existence and comprehends it through the practical results of all his executing states. Moreover, man becomes the determinant of the true meaning in all his surrounding objective reality within the framework of those capabilities that he is endowed with through

the functions of his Brain or which “have been opened” in him thanks to the use of *the "SvetL" Programs*, which is also important. New born children are gifted with such Brain functions of a higher and more harmonious level nowadays, and mainly in Russia. This is becoming a reality – what is given by the Supreme State of the Mind, that in what one is gifted with for life! I want to emphasize – **THIS IS NOT A DOGMA**, as *it is natural* as a forerunner of the developing subjectivism of the future life of man. This is the highest goal which **EVERY MAN WILL BE CONCENTRATED ON** thanks to the functions of the true perfect Brain as a subjective inimitable ideal bestowed upon him. In this connection *the state of faith will acquire a completely different level* and meaning, since it will rely on another world view and understanding of its true place as an individual among the surrounding realities, ranked, in turn, by its mission and grandeur in the overall harmony of the universe realities.



Man, being already gifted through the functions of the Brain of higher octaves, with a state of self-control and the ability to consciously isolate himself from any negative vice in his life, and realizing the true meaning of the whole surrounding objective reality of other realities surrounding him, including the sense of his existence among them – **can not be subjected to violence on the side of his kind**. I know that this is already understood by many in their realities. **No society, no matter how perfect its construction, can ever do for each man so much as the man himself is able to do and realize for himself for the sake of his own perfection, but not in the subjective vicious interests of the wealth predominance over others, as it is still happening today**. If Man realizes the meaning of his actions, understands the role and the truth of his existence as a Human being, and not a biokiborg controlled

from outside, then whatever he does, ***he will do with inspiration and purposefully*** for all equal to him. Everything else – is always violence over man and it does not matter whether it is manifested in a mild or hard form.

5.9. Expectation of realization

The third psychological component of human happiness is ***hope (self-realization of individuality)***. Usually they say that hope is expectation of the realization of something joyful, favorable. However, if faith is irrational (it is impossible to prove the truth of what constitutes the strength of a personality), then **HOPE IS RATIONAL** – it has to prove its rightness with facts, calculations, logic, research, figures, and analogies. Hope is based on graphs, diagrams, information on "moving forward", fulfilling plans, etc. Giant "brainwashing machines" – the media – create, "mold" hopes of various sizes, shapes, and configurations. But at the same time they destroy those hopes that are not included in the plans of the realizing policy.

The policy is secretly based on the comments to the hope that the Holy Apostle Paul gave in his Epistle to the Romans (**Ch. 8.**): **"For we are saved by hope. But hope, that is seen, is not hope, for what a man sees, why does he yet hope for? But if we hope for that we see not, then do we with patience wait for it"**. From my point of view, "patience" is a very hard and long way of Man's development, gaining his individuality, which, through its self-realization, produces hope. It is believed that faith and hope do not remain in the same state: faith turns into "vision", hope – into "possession". This is their fundamental difference. Hope is embodied in the material attributes of human life, behind which are science, politics, production, economy, culture. Hope is based on the ability of an individual to understand the abnormalities, imperfections of his existence, and find ways of salvation and improvement with non-trivial solutions. Hope sees the invisible, feels the imperceptible, and achieves the impossible. Some people think that our hope today is delusion. It is weakness. But they are wrong. It is our hope that allows us to survive in these hard times. It makes you bend but not break. And this hope with faith in knowledge allows us to win. It is hope that makes us human today. The possession of hope is not given to all people, but only to individuals, called so in psychology, for example.

The fourth psychological component which forms the experience of happiness **is work** –creation of consumer value (self-realization of the subject). K. Marx defined work as consumption of manpower. Naturally, the expenditure of manpower entails the so-called difficult states: tension, fatigue, monotony, stress, which Man avoids for obvious reasons. He wrote: "In addition to the tension of those parts of the body which do the work for the whole working day, an expedient will is necessary, which is expressed in attention, and moreover, the more he needs it, the less interesting is the process by its content and the way of execution, that is, the less a worker enjoys his work as the game of physical and intellectual strength". Therefore, everything was done in such a way so that the most strength was used up **to unite the worker with the object and means of work**. K. Marx noticed that "the buyer of manpower consumes it, forcing its seller to work". This happens because the object of work (land, coal, cattle, etc.) is heavy and dirty, it exhausts Man. Work is a heroic deed. Therefore a major part of Humanity is trying to avoid work, completely failing to understand the direct difference between work and such convenient, in all respects and imposed form, as labor. There are many who are not able to see any difference in this respect. But also the means of work require maximum stress in labor, causing occupational diseases, disability, etc. A jackhammer in a mine, a crawler tractor in a cold field, working with children at school take all the strength of Man. The so-called politics has always been looking for more and more new methods in order to connect **NEW WORKERS WITH THE OLD OBJECT** and new means of work, otherwise the Lifesupport of the society or rather the wellbeing of the so called "rulers" will stop. **Nevertheless, it is work, and not the notorious labor is an indispensable condition for the happiness of Man:** only in the process of work, a child born by Man becomes Man himself. The mystery of work lies in the fact that all mental processes, properties and functions of Man develop only in a **NATURAL PROCESS OF USING UP THE MANPOWER**. The properties of the subject: thinking, will, affect, perception⁶⁷ – become human only in the process of exhausting exercise of the mind, will, muscles, which cannot be interrupted on one's will due to fatigue or monotony. No work surrogate (game,

⁶⁷ Perception (Latin. Rercipere – perceive). The first steps in studying the perception process were made back in the Antiquity, then it was reflected in philosophy, physics, and arts. A special contribution to the study of nature of perception was made by the German philosopher and physicist Gottfried Leibniz. His theory of "small perceptions", for the first time in history, explained the difference between a conscious and subconscious state of mind.

especially sports) develop the higher mental functions of man, which are the main goal of civilization. Man himself builds up his personality, overcoming himself and nature. **Work is a mandatory condition for the happiness of Man for the second reason, as well:** in the process of work a product is created (material, intellectual, aesthetic, ethical) that has consumer's value. This means that it is vital for people. And this product is subject to be carried to another Man.

There is no other purpose for the result of work – it is always for others. At the moment of carrying the result of his work, Man is experiencing the fullness of being, associated with the self-realization of the subject's functions – this is a moment of happiness. People, who, for some reason, are cut off from work, are formed as inferior people, as people, who never experience real human happiness.



Politics has to see to it that percentage of such people in the general mass of the population is as high as possible, so that, first of all, the so-called system of mass control" is observed.

Through all the stages of economy development and improvement people had one motivation – **to work for material wealth and services for their survival.** In short historical episodes – of socialist production, work was taking the form of "honorable duty", and in other cases, work always was of a voluntary-compulsory or, more often, of compulsory character. The attitude towards working people was not changed as well; Oppression and depression were getting more perfect by various administrative or technical methods. Recently, in connection with the processes of globalization, which divide the world into the periphery and the center, there have been additionally taken into account which cultural values and stereotypes impede the international unification, as well as contribute to the economic prosperity. But all this is not for the working people.

For the proper organization of human life it is extremely significant, as I said, **THE DISTINCTION OF CONCEPTS OF WORK AND LABOR.**

It is amazing, but so far these concepts have not been distinguished with unshakable and inexplicable stability. As a veil of curse overshadowed the eyes of people, but this distinction is far from being simple and is rather deep and functional. Now most often in the teachings of current sociology, the concept of **"work" means a contribution to the production process** made by people in the form of direct expenditure of mental and physical force. As it is now understood, it is aimed at adapting the habitat to meet its needs, at turning material and intellectual resources into a product necessary for personal or social consumption, at producing goods and services. Work is the basis of life and human development. Is it true, and if it's not, then why? It turned out that work, in the definitions of those who formed life foundations, **lost any kind of spiritual and moral content**. Was it a coincidence, especially for Russia; were people free in shaping such subtleties in relation to work as the basis of life activity and their development?

Erasing the border separating one from the other was also programmed, but hidden from the true awareness. But what for? In this regard, there is a direct need to show the true reasons for the difference between work and labor. Apart from the true provisions on work and labor recognized by science, it should be emphasized that working activity influenced by the programmed Control of the Old System **PLAYED a SIGNIFICANT ROLE, IN THE LIFE OF PEOPLE** but it was only of a **PASSIVE EXECUTIVE** character. As soon as there was no need for such executing functions, the System cleaned up such an unnecessary mass of people in a natural way (mass epidemics) or administrative-historical aggressive extermination (wars). Only people were not allowed to understand the true situation and their role in the process of the program execution through their working activities, their real level of their utilization as low-willed material involved in the processes of controlled development, their humiliating function of experimental application according to the plans from outside. Therefore, the executors and their science were seeking out for far-fetched problematic stuff to justify and cover up the true meaning of this subject. The problem of distinguishing between work and labor rests in the very essence of Man formation as a special process of his material utilization, **as an object for improving his "shirt" and developing various Brain genotypes through the forcible experiments on Man** under the influence of the programs, acquired from outside against his will.

The application of the research method of energy-information dialectics on the externally controlled process of the Brain development made it possible for the first time to come to the most important philosophical conclusions and definitions: "**LABOR**" **IS THE STATE OF THE PROCESS OF EXECUTION** for implementation of the comprehended objective reality to satisfy one's programmed needs as acquired control energy information. But we already know that the needs themselves are also shaped by the program without people's will and wish.

"**THE NEEDS**" **IS THE GOVERNING PROGRAM** for the people's Brain development, changing as its energy-information saturation becomes more complex and is an indicative, that is, the ultimate programmed "recommendation" for determining the degree of pressure of work in the process of the state of execution "labor" or "work", being a conscious initiating beginning of man's actions in his habitat. The program of "needs" is a basic start of labor and work. However, it should be said about one very important functional imposition in the control program "needs" – this is a "pre-emptive ban", which was an extremely important beginning in formation of people's *ability to realize objective reality* within certain limitations introduced to people from outside and not dependent on their will and wish.

The transition to the digital basis of the construction of all energies control information and introduction of Brain **genotype 422** made it possible to improve the sphere itself and the depth of the imposed knowledge, that is, the process of introducing some "scientific" knowledge has begun. Based on this, a causal basis was formed for the introduction of a programmed state of execution – "**work**". So what is "work"? Before introducing the definition of the state of "work", it is necessary to make those mandatory mutually harmonizing conditions within which it, as a controlled program state, must be effective in execution on the part of *individuals of the selected genotypes* of the Brain. With all this, the "working" process should not be only of a one-sided character of the executive program state, i.e., an active control state only on the part of the affecting functioning Control Complexes. An active duel situation on both sides is necessary.

Only a separate part of people is subject to the executing controlled program process "work", which is directly affected by the introduced special functions of the Brain, through which this genotype, in fact, develops under the System Control and only within its defined program goals. Mandatory framework conditions, both of the embodiment, and the

very being of the controlled executing program state "work", as such, include:

1. Activation of the endowed special Brain functions as representatives of a specific genotype unconditionally provided with and supported by this subjective state in the interests of the target process of the programmed implementation, as transmitters of the provided knowledge and executors from the Control Complex.

2. Participation in the specific targeted process of receiving energy-informational enclosures and commands sent by the Control Complexes, their manifestation through the awareness of the objective reality and the formation of governing or cognitive conclusions.

3. Adaptation of the conscious objective reality or manifested conclusions and their conversion into a subjective initiating principle for the satisfaction of special class needs through the implementation of the governing actions or the accomplishment of knowledge.

The combination of these conditions, being in a state of mutual harmony and the mandatory effective presence of all the three, is the very executing program state – "work". ***Inaction or lack of at least one of these conditions turns the executing state "work" into a state of "labor"***. In this connection, there appeared a new true definition of the program-controlled state "work": ***"Work", as a controlled executing program state, is the process of manifestation of an adapted awareness of the objective reality and formed governing or cognitive conclusions for the individuals with a specific imposed Brain genotype and conversion them into an initiating start for actions to meet special class needs, aimed at the implementation of governing functions or accomplishment of cognition.*** The same can be attributed to those people who have begun to use ***the "SvetL" Programs***, but only at the initial stage, depending on their awareness of the objective reality. But this is a significant step forward against the backdrop of what is happening with everyone. As you can see, Work is a **SPECIAL ENDOWMENT OF THE ACTIVE AND OTHER PARTICIPATION OF DEFINED GROUPS OF PEOPLE** in the actions and events of the programmed Target Vector, ***being beyond their will and wish, and predetermined by the program.*** This active and other participation is manifested through their specific functions depending on the Brain genotype. Only governing programs can be ranked that provide such

an executing state as "needs", "labor" and "work", but even that was within the framework of the old programs, beyond the possibilities, free choice and influence of people. ***People were used only as things to be utilized!*** The majority did not have the prerequisites to be involved in the executive program state "work", that is, they could have only the state of – "labor".

During all stages of the Brain genotypes development, there took place programmed changes not only in the executing states of needs, work and labor, but also a complex hierarchy of divisions of the introduced program-executive quality level – mentals and assements in each class, both governing and governed, with an active impact of the governing factor “immanent”, which initiates only functional actions to satisfy its program-gained "needs" for each. Beforehand, the System concealed the **ENCLOSED MANDATORY CONDITION** of guaranteed separations in all processes, played a decisive role in the irreversible separation between work and labor, final establishment of an insurmountable barrier between them and an additional internal separation between “work of the governing” and “labor of the governed”, especially among the governing class circles.

A complex hierarchy of divisions has been formed, which comprehending and taking into account when doing research on any issues related to the organization of people's being, becomes not only relevant, but also mandatory, since without understanding this, the true state of affairs will not be clear. The intensity of changes was so great that without the methodology and research method based on the energy-information dialectics of the Brain genotypes development, it would be impossible to reach the truth. For this reason, indeed, in the basic definitions related to the needs, work and labor, there was complete confusion, which representatives of many sciences have not been able to figure out until now. Thus, there was interspersed the entire subsequent and main mistake of theories of people's being, every scientifically grounded qualification and definition of types of labor and work using the mind or the muscles, activated and inspired with communist, capitalist or spiritual plan slogans, etc. – **ALL THIS HAVE BECOME DOOMED AND ABSURD.** ***Can such work be an indispensable and mandatory condition for the happiness of Man?*** Of course, in the future basis of the new ideology, this situation will be unacceptable. ***Today it is not correct and not justified to be engaged in polemics and judge in another way!*** All the subtleties of distinguishing the executing states of “needs, labor and work,” the hierarchy of additional program factors affecting in the past programmed

accomplishments is obvious and manifested as a controlled process. The degree of people's use as material for utilization, as the forcible violence in the framework of the former program processes, is increasingly being lost day by day before our eyes. But this process cannot be uniform and has a discrete, but increasing character in the direction of the strategy of transition ***from the forced state of the things-like use of the "People of Labor" to the voluntary social aspirations of "Man of Work"***. Consciously understanding the importance of his personal mission, Man will be differently aimed at, spiritually and mentally striving towards the results and the quality of his work, thereby acquiring self-controlled conscientiousness in all his deeds and actions. Only such an attitude and such a level of conscientiousness of the majority of Mankind will make it possible to come to the universal harmony of life on the Earth. Its universal participation, including work, Man will implement sensibly, i.e. with full aspiration for conscientious understanding of his truly realized personal function, as a Man and as an important element of the universal harmony of life on the Earth. This is the most important conclusion from all the above.

The main problem of today's human condition is in his microstructural psychological nature, in which, like invisible atoms and electrons, are hidden: Man's happiness, the sense of life, his goals and values. They cannot be seen, their meaning can not be understood without special knowledge, based on the new comprehension of everything that is happening today. Any scientific research is unlikely to help here, within the framework of today's "science."



Similarly, at the dawn of modern civilization, few people had an idea that experiments with invisible electromagnetic lines, traces of the radioactivity on photographic paper will lead to the basic achievements of the twentieth century: electricity and nuclear energy. The state of research within the framework of Human Potential today is comparable to studies of mass epidemics before L. Pasteur's discoveries, with research on substances before creating D.I. Mendeleev table, with calculations of engineering structures before creating Leibniz-Newton mathematical analysis. In social science disciplines to this day, such an intellectual leap has not yet occurred, and therefore they prefer to talk about the threats of what is happening, and not about the possibilities that the ongoing provides to those who penetrates into its secrets.

But I am interested first of all not in the happiness for all people, but happiness for every single man.

Chapter 6. To see the sound and to hear the colour

Kozma Prutkov used to say: "Flick the mare on the nose – she will wag her tail". Why she is wagging her tail – nobody knows to this day...

All of us, as the principle of consciousness, and the whole of the world, as the principle of the space firmness, are consciousness, and, therefore, this level of firmness is none other than us, as a whole, and in particular. If you fall to thinking about it, it does not seem strange. Indeed, in nature there are neither physical laws, nor formulas, nor individual factors and characteristics. In nature, there is something holistic, complex. Generally speaking, except for Nature itself, nothing else exists in nature. Our weak Brain is forced to create theories, make up systems, carry out multi-factor analysis in order to try and at least figure out what is what. But today, there are many, and even most people who do not share this approach. Whole schools and trends deny a systematic approach as an adequate tool for understanding the structure of nature and man. There was a **sage** thousands of years ago – **Lao Tzi**. Through him, people were told: "Why, You do not suffer! The secret key to *cognizing the truth of everything* looks very simple. **ALL EXISTING IS ARISEN FROM BEING**. Full stop. **AND BEING – FROM NON-BEING**. Full stop". All existing! What else should we discuss? However, we have been discussing it for a thousand years, but have found no answer. So it was intended like this, wasn't it? Now we know that it was. But first of all, we have to understand what we should do to become Humans, what has begun to show in us or has not begun yet ... and get to know where the acquired lays, in what way and what comes out of it.

Psychology as a science along with other sections of the so-called "scientific knowledge" was created with the programmed goals that were not focused on the evolution of the Mind of man as a creator. It is written in the previous chapters. In my publications and not only, it was repeatedly mentioned that the only purpose of man's existing and even seems to be developing on the Earth for the last millennia was the process of multi-step solution of the task of combining the Brain of Man recreated by the interventionists with the Brain of interventionists and its subsequent

introduction into man's shirt. Any of the currently known sciences has developed within the framework of these problems solution. Psychology, as it has probably become obvious to the reader, is a powerful tool for guiding an individual, groups of people, masses of people; individual's development and formation and these structures' functioning in the required mode. At the same time, like any "modern science", especially one way or another isolated from the general system of knowledge (and such are, in fact, more or less isolated scientific sections with missing personnel), psychology structuralizes information about man, making it possible to use it for controlling purposes. Competently applied, it can be used for good and the other way round. According to the Program objectives of that Control System, the psychology application in the past was carried out for the good (but from our current position – to the detriment). Similarly, its application today can and will be for good, but already within the framework of the tasks being solved by the native Control System with the purpose of developing Man as part of the developing Mind of the planet.

Of course, any structuralizing, including the separation of psychological science and its use, is simplification. But at this stage of development and in the current circumstances, such a simplification is just expedient – the existing psychology trends, techniques and methods can be consciously applied by people without any particular difficulties, which inevitably arise while trying to comprehend the reality from some more advanced positions – in this case, the number of pitfalls on the way (if only a simplified state of the modern Human Brain) will turn any generous impulses and efforts into rather meaningless attempts. Therefore, gradually and without rushing, plunging to a possible depth in one or another area of knowledge, we apply the comprehended information obtained from other positions for the purposes of our own development and in the framework different from the programs of the old CPS completed ahead of schedule.

In the last chapter when reasoning about the integral indicator of the **HUMAN STATE – HAPPINESS**, we touched on a lot of things and actually made it clear how to become happy. But there are various ways of influencing man and his, let's call it, possibilities to become happy. You can make man feel imaginary happy, thereby stopping his quest for happiness. By manipulating the formation of components that add up the experience of happiness, one can control man's activity and his life aspirations. And to implement this in the existing prison-like infrastructure built around human society and in fact built into it – is not difficult at all. In the current

conditions of human existence, these tasks can be solved, and those that were started up earlier are already being solved with success. It is enough to put together and make public the version of human happiness, correctly arranging it in accordance with the components of happiness that we have discussed – and the overwhelming part of the population, built into the system of the so-called public information, will swallow the options presented – people will feel happy. For many, it will be family happiness, for others, for example, there might be enough happiness of motherhood or fatherhood, for the third, happiness is commensurable with the amount of money and things that they own. Do not forget about the consumers' society, which we have created with our own hands and out of which we have to "get out". For some, the designation of some kind of "obligatory" happiness is tantamount to getting a purpose of life, and it can be enough for a very long time – then all the other components of happiness will remain unfulfilled, but at the end of life spent on something one – specified (obtained as some attitude in the Brain), it turns out that the quest was for something completely wrong.

It is possible to make an impact on man in quite a different way – to go beyond the limits of the psychological science categories and take as a starting point, as if, the consequence – the level of human development. If you directly control the development of man, his formation with the help, at first glance, of some simple methods, you can get the set controlled biomass at the output. We touched upon this subject a little bit in the second book when it came to frequency modulation. If this method is applied even in some limited way, the effect is going to be amazing; for example, to organize a controlled musical space for all people. As it turned out, it is not at all difficult to implement it, and everyone is covered (except for people with sordological⁶⁸ problems). And in fact – there is no coercion, everyone is choosing according to one's taste, but from the existing set (given – even when it comes to some prohibited options – and it works even more efficiently), and the main mass of the population is brainwashed to the stage of biomass formation.

⁶⁸ Sourdologia (Latin *surdus* – deaf) is a section of defectology that studies the problems of adaptation and social rehabilitation of people with deafness or hearing impairment.

6.1. Adaptation to the ongoing

The basic problem and the trouble of our present day life is that at the basis of all thinking and attempts to build anything on it lies a false foundation. Why can't we get out of the most difficult situation in which we find ourselves now? Because we believe that our delusions are random, transitory. They are inevitable and stable due to the specific character of our thinking, which we are going to discuss here. Let's go back again to the works of N. Levashov, and, in particular, to the "**Final Appeal to Mankind**", where the **Third Appeal to Mankind**⁶⁹ is given in the beginning, in which the modern level of knowledge and delusions of the inhabitants of the Earth are very intelligibly defined.

Any scientific or legal law, the meaning of any discovery or invention, the essence of any important idea can be expressed by a simple sentence, consisting of one hundred words out of a 50,000 word vocabulary, including mathematical and other specific symbols. The total number of possible sentences of that vocabulary is represented by a very modest figure, equal to 100. If we consider only those sentences that have an analytical function, i.e., convey meaning, then their number will be reduced to 50. If we now discard phrases in which the words are grammatically correct but lack even the slightest discernible meaning, then the quantity of meaningful sentences remaining will be reduced to 25. Finally, if we then select the false statements from the true ones, being generous with the former in our evaluation, we have only 3–10 statements remaining that actually correspond to reality. Evidently, it would be more correct to consider humanity not intelligent, but as a **potentially intelligent race**, since, the limitations of our thought processes, as you should have already gathered, **ARE NOT OF CONGENITAL ORIGIN**.

The last phrase emphasizes what I am talking about in my books – the forced and programmed people's Brain development in accordance with the plans of the Ebr system and the real opportunity today to "intervene" in this process and correct a lot, if, of course, there is a quest for knowledge. So let's go this way. When some principles for development are selected, the implementation method is finally chosen. When we manage to reach the

⁶⁹ Third Appeal to Humanity. Russian text. Given in 1929 AD. The Coalition Group of Observers (K.G.O.) appeals to the intelligent inhabitants of the Earth, to the race that calls itself Humanity. Submitted by Shambhala intermediaries E. I. Roerich and N. K. Roerich.

level of the base of consciousness – the material level – then the assistance from the Control System has already been rendered, it has become for the whole future world – in the Russian language. This is the basis of consciousness of the future of Humanity, and no one will be able to change this. Consequently, those who know Russian speak it; think in it, will be easier to fit into the future stage of evolution. It will be more difficult to convince other peoples, although everyone knows the power of the Russian language. The problem is that man forms his consciousness far from the principles he is to develop in the future and it will not be easy for him to overcome it. Every nation will have its own problems, they will have to be aware of them, and those who have already realized it, began implementing them. Schools of the Russian language in Syria, Turkey, the recent request of the leaders of the former Soviet republics to increase the number of students in Russia, with the subsequent introduction and restoration of the Russian language through these people in their homeland. – all this is the proof of that. The readers of this book, – look more carefully around and you will find a lot of evidence of what I am writing about.

Nature will most severely expect us to be in compliance with the specified levels in this and the next stages. This problem is very complex, and it will be necessary to find its solution (you can not will success). I constantly think about it – one of the ways to help solve these problems is to bring ***the "SvetL" Technologies*** outside our country. This is hard, but quite a surmountable way. I do see that by reforming a lot of shortcomings in any man, it is possible to correct his consciousness, but to make whole nations follow this principle will be very difficult, because they have **TO GET TO THE IDEA THAT THERE IS NO OTHER WAY OUT.**

One of the significant fragments of the ongoing is the correction and re-creation of the native Complexes of the Earth Control System to form the true complex energies being, which will inevitably bring to, and, in fact, is already showing us the changes both in the intensity and the very essence of the energy information life support and, first of all, for people. This, as an inevitable consequence, has caused fundamental changes in the world view of people in relation to the previously established truths. All this can be achieved only on the basis of the appropriate account of the new higher level of knowledge provided to people by the new Control System. In turn, this leads to the change in the resultant product in the awareness of the objective surrounding reality, – a deep correction in the very essence of an individual and social consciousness of people. At present, this process is already taking

place in the most active way, and I mentioned it in the previous books, **BUT WITHOUT PEOPLE'S COMPREHENSION OF THE TRUE MEANING** of the manifested changes and visible effects of everything happening. So far, it manifests itself only in a **CONVENTIONALLY COGNIZING** limited form. At the initial stage, this is expressed through some kind of auto-motor-like rejection of all traditionally established types, forms and states of the past world outlook, independent of people. There arises massive manifestation of inner dissatisfaction with everything taking place. ***In particular, there is discontent with the real-life worldly processes, associated both with changes of a global nature in the world around us, and in the search for a new comfortable place in it.*** There is a growing dissatisfaction with the construction of the society's modern social arrangement, organized for the present day living people by the collapsing states of the organized being within the framework of the preserved norms of someone's previously established conventionally accepted "fair" law dictating and shaping unfair organized coexistence for various social levels and groups, mainly continuing to rely on the minority's violence over the majority



The majority of people who are now in the state of irreversible "non-humiliation" in their life position regarding their own participation in various spheres of their being "organized" for them, involuntarily experience so-called "rebelliousness of consciousness", both individual and social. This causes numerous ungrounded speculation, rumors and assumptions. But this also causes a strong panic in the so-called "powers that be", which rush

about and do not understand why their plans and predictions fail. For the present, this is quite a regular behavioral and executing process that is beyond the will and desire of people, because the former contented energy-information support of the old Control System, which previously maintained the previous levels of understanding at an adequate level of efficiency by its information control translation, no longer exists. The new process of energy-information support on the side of the new System **FOR THE GENERAL MASS OF PEOPLE** is effectively impossible so far due to the limited level of the functions' state and their Brain reaction (in all its three states) in the changed conditions of energy gratings, which form in a complex way a reasonable life support as such. Below, I will tell you why. Thus, so far the Control System can not effectively change people's consciousness, because of their limited ability to receive new energy information translation of cognitive nature, partially deciphering and transmitting it, and therefore **LIMITEDLY PERCEIVE AND COMPREHEND** the whole reality of the changes in general. That is, now the changed energy-information essence of the surrounding objective reality is perceived **ONLY BY A VERY SMALL GROUP OF PEOPLE (INDIVIDUALS)**. This situation should be taken as temporary. This is precisely that important problem and that main peculiarity of the current traditional processes of the people's being control for the start of the Transition period, which cannot be realized by the majority today, but has to be certainly taken into account by the leading and outer-initiated **GROUP OF INDIVIDUALS**, who, in fact, were entrusted to get aware of this for a number of reasons independent of them! But it is necessary to make it so that these individuals – people aspiring to become Humans, should grow in number. This is the main point in the creation of *the "SvetL" Programs* (no matter who and what said about them), used consciously by people and with an emphasis not only on their health improving, but also personal development, which, unfortunately, based on statistics, which I make, takes second place. For the majority, of course, primary is recovery – against the backdrop of what is happening to the so-called medicine. Now, regarding those who is thinking, – this group of people which is becoming more and more numerous categorically should not be perceived as a kind of new "selected". Impostors, in the sense of some "particularly selected in the past", are no longer in demand in the present and future history. If someone disagrees – take my word for this. And time will tell.

6.2. To see an apple and recollect the "spare parts"

In order to protect oneself, or rather, fit into the ongoing and begin to understand it, we will go on learning – where you can get the knowledge that will help not only to figure out the situation, but also (do not take it for pathos) – to survive. Before you consciously apply the **"SvetL" Programs**, you have to understand what lies in their foundation – what is the principle of work today, why they worked like this yesterday, and today it is completely different. Is there any possibility to learn to "control" them? What energy should the user have? What and how do you have to build in your Brain, interacting with the Programs? What are the principles of building structures that simultaneously provide stability and the possibility of development and evolution, without losing anything, but gaining, and taking the place defined for us by Nature or, more precisely, the Life Support System?

We already live in a new system, developing independently of us and our opinion, and we have to make it clear for us the mechanism of its formation, that is, the principle of approaching it. In what way are we going to act? Just to state at the level of philosophy that there is a law of quantitative and qualitative changes, which is transformed depending on our understanding or misunderstanding? Or rely on the "advice" of psychologists and psychology itself, which I described in the previous chapters? Of course, not. First of all, we have to clear up how our consciousness from the principle of the primary, plane, linking the imaginary, transcendent, rational, actual into a single whole, transforms into what we call human Mind, human Intellect. And having mastered what I have already told you in this book, and not only, and which has become your knowledge, you can convey it to other people, of course, if they wish. This is their freedom of choice in the quest for knowledge. And if man does not want to accept, then the information provided by you will not enter him and not affect anything. But that is not your, but his choice. The "simplicity" you comprehended will remain a void for him.

The foregoing relates to the level of my fundamental reflections and generalizations that have become possible after all that I learned from the works of many authors listed more than once here and from talks with Nicolai Levashov, and not only.

Here, for example, in front of man is an apple – he sees it in all its details: skin color, petiole, rounded shape, some surface gloss. This is what

he sees. But perceiving visually, on the basis of the information received earlier (with experience), man can add much more to the description – for example, what sort it is, what weight the apple may have, what it is like to the touch, taste, smell, how to make juice from it. Moreover, there may be a desire to eat it (if there is a need for what this apple contains, and the Brain by the visual image and the rest associations determined that it would be nice to eat



it.) This desire can be instantly suppressed (actually disappear), if you "add" a child to the apple who wants to gobble it up – various other parts of information obtained with experience are included – an understanding that the metabolic processes in the child's body can be "more intensive" approaching some critical points, that is, just he needs an apple more than an adult, this will stop all the processes started in terms of eating. So, it turns out that one simple apple – and in humans, a **GREAT NUMBER OF PROCESSES** is included **SIMULTANEOUSLY EVERYWHERE** – both in consciousness, and in the mind, and in matter, and, of course, not as parts of the whole, but as a single construction. And now we ask the child to draw this apple with a simple pencil. There is no color in the picture, there is a very approximate form, by which, however, you can still surely "recognize" an apple, and then all the processes can be included almost the same way. Man "thinks out" of both color, taste, and variety, and weight, and possibly even better than when looking at a real apple. There may even be a desire to eat – but not a drawing, but a real apple, and thoughts like "to treat a child" can also be formed. But all this is only because by the time of the drawing contemplation, man has accumulated some information about apples and about a multitude of related phenomena and facts related to it in one way or another. Should it not be such an experience (previously had and thought over) – the drawing would not be able to start up everything described. ***You can't draw what you don't know – have never seen, touched, listened to the descriptions, read,*** that is, have never got any information about it.

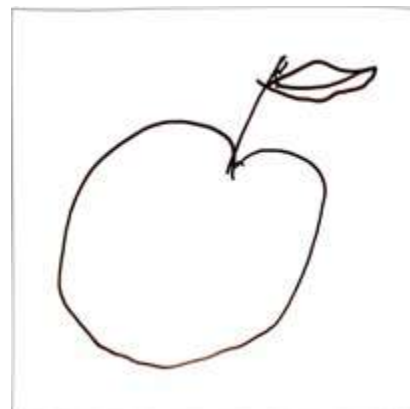

The basic here, as the reader has probably realized, is information that can be obtained only on the condition that man is ready for it. But in order to comprehend this, you have to return to man's "construction", his "spare-parts" and what these "spare-parts" consist of, and how they are controlled by the Brain. All this will provide for a deeper understanding of **the "SvetL" Programs**, their potentialities and, I do not exclude, on the basis of data not only from this chapter, – to try to create something similar on your own. All the given calculations are made by Alexander Khatybov. In his time, the mechanism (algorithm) for creating Programs was agreed with N. Levashov. The calculations are authentic, tested and realized, and not only in **the "SvetL" Programs**, but also in other Technologies. I am sure that it will be interesting to the readers, I think many will find answers to their questions after reading my books.

6.3. The "spare-parts" structure – chemical elements

Turning to the "spare parts" and the structure of building chemical elements (atoms connection) of the "spare parts", we first return to the atom structure, which determines the structure of our own world, in which we exist today. This is one of the initial fundamental structures, and therefore, the way we (and the whole of humanity, I'm not afraid to say it), understand an atom structure, the same way we build on this foundation what we want to create or construct.

An atom is not yet a substance, in general, but a molecule (group of atoms) is one hundred percent substance. This idea was the basis for the Programs creation All this a hundred years earlier (it's true, – within the framework of solving the Old Control System problems), Rutherford and Bohr found it possible to give some planetary appearance to atoms form. They liked our Solar system. Here, in their own image, **WITHOUT BURDENING THEIR THOUGHTS**, they "staked out" the planetary structure of an atom. And what did come out of it? This structure immediately caused **questions of mean nature**:

- Where do electrons take energy for revolving?
- How to make substances and bodies out of this fidgety structure?
- And how to make crystals (reactors, to which we turn later)?

- Why is there no "annihilation" if an electron connects to a proton?

- Where is that atom energy that is released during nuclear disintegration?

And why... And where... And how... and quite a number of other questions that had no answers.

But instead of qualified answers, questions are overgrown with hypotheses, like dead trees with moss and parasite fungi. This is the logical end of any unrealistic hypothesis, which was the Rutherford-Bohr hypothesis about the structure of an atom. Maybe, out of great respect for Rutherford – an experimenter, or for some other reasons, this hypothesis is still alive.

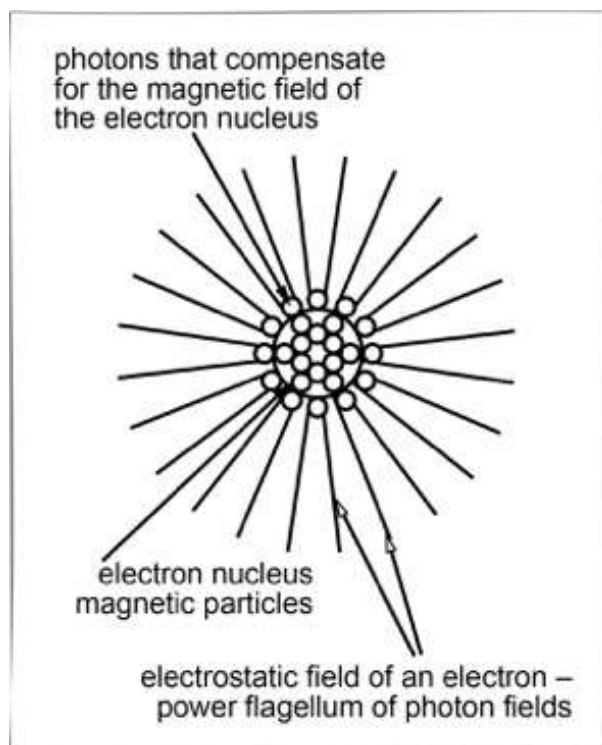

Electron Structure

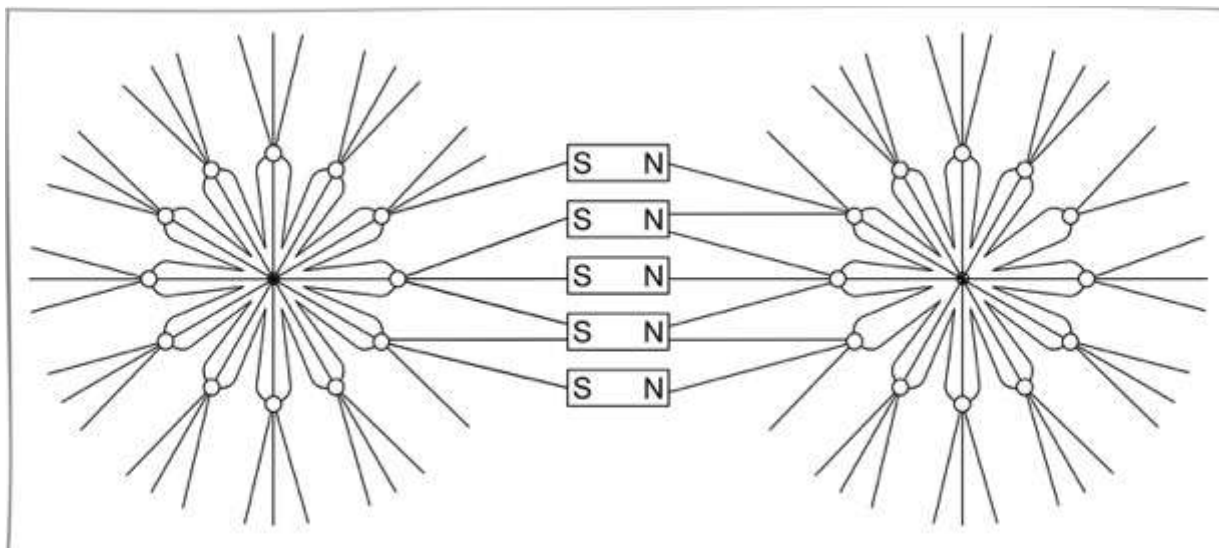

A molecule

The situation is similar to a leaky ship hull: the hole is plugged, – good. Plug others, and as for a thorough repair – that's later... But time is implacable. Man can live for a while in a lie, for example, believing in something unreal, but metal cannot stand a lie. It begins to bend, break, and corrode. Therefore, I am saying it again, as much Humanity understands an atom structure, so much they build a structure on this foundation, and as

much close this structure is to the real one, so much perfectly it will fit into the World architecture.

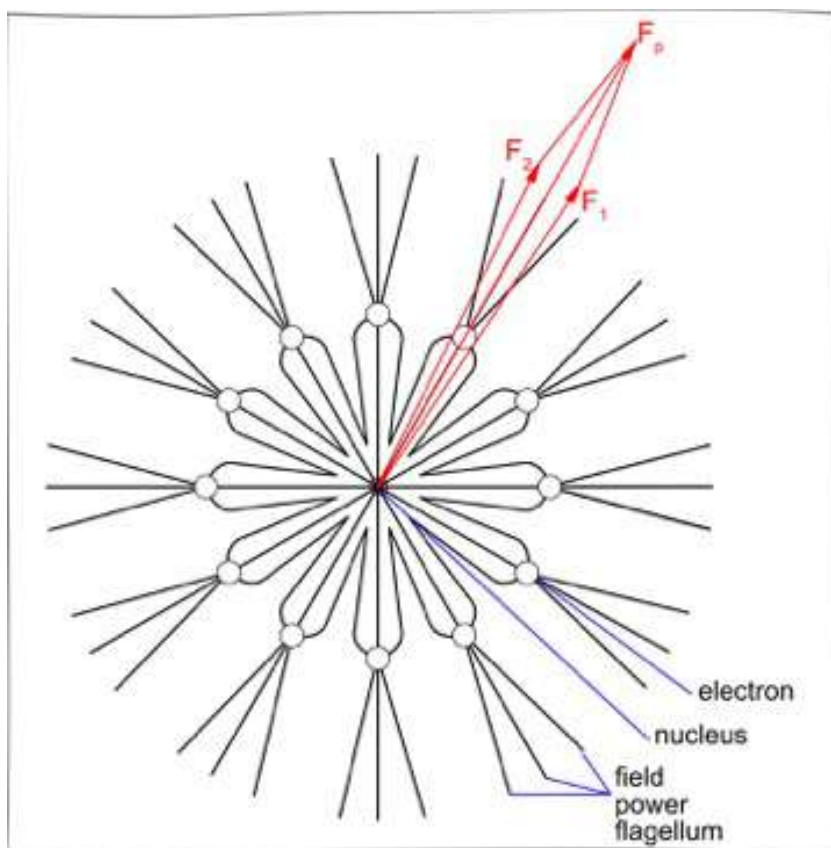

Atom structure – (diameter cross section)

In fact, an atom **has a three-dimensional volume structure**, and the resulting force F_p increases significantly due to the action of Coulomb forces lying in a perpendicular plane. As you can see, at least four electrons try to push one electron out of the atom electron shell. It should also be noted that the connection of each electron with the atomic nucleus is stronger than the connection between magnetic particles in the nucleus, since when an excited nucleus of an atom breaks, and electrons participate in this process, retaining their bonds with nuclear fragments, the nucleus breaks into several fragments and together with new electron shells, it acquires large kinetic energy – the energy of destruction of the atom matter. And all this is made by the potential energy concentrated in the atom electron shell. For the curious, this is one of the principles of **the Generator's "work" through the "SvetL" Programs**.

Thus, we see in the atom a zone of **POTENTIAL ENERGY** concentration as **REAL**, but not fictional, and this energy in the electron shell increases, one might say, in proportion to the square of the number of electrons in the atom electron structure. There is not much of it in atoms

with a few number of electrons in the electron structure (shell) and very much, for example, in Uranus (92 pcs.) and elements of this series. The shown structure of an atom makes it possible to identify the places of concentration of the atom potential energy. It is missing in the nucleus, because ***only gravitational forces work there***, which **CANNOT IMPART** kinetic energy to the nuclear fission fragments. There is such energy in the electron shell. With the weakening of the attractive forces in the nucleus, the Coulomb repulsion forces in the atom electron shell are able to break the atom's nucleus into several new atomic formations and impart them kinetic energy, too, *correctly called atomic, not nuclear*.

We could see how bodies and substances are formed and we found the potential energy concentration place and the mechanism of its extraction without attracting hypotheses *from the "dark" forces*. It already looks like a science that is clear and correct – without fictions and inventions, and even more so, without the comments of "experts of Levashov knowledge". In this structure – an atom – we see that it is reliably protected by the flagella "strands of wool" of the electrostatic field. Nature shows here, too, that *it reliably protects its production from related structures*. But having a cover of flagella (this is fundamental for the "construction" of Programs), it cannot be connected with another atom – unless through the medium of magnetic particles. Free magnetic particles are attached to the free flagella of an atom, for example, by the north pole, and another atom is attached to the south pole with its flagella, creating a formation with new properties – a molecule.

A crystal is formed in the same way.

This ordered crystal structure is again tightly bound by magnetic particles into an extensive figure, the strength of which is well known from experience. But this figure remains a collective structure, which through its free flagella and magnetic particles is capable of forming its own crystals (reactors, when it comes to processes at the cellular level in biology) – growing them. We got crystals (reactors) and molecules, and these are bodies and substance. Regarding man, only the Brain can realize all these processes, controlling everything, but if it is capable of it in its development. If "not capable" – it has to be prompted. Who will do it and in what way we are going to know now.

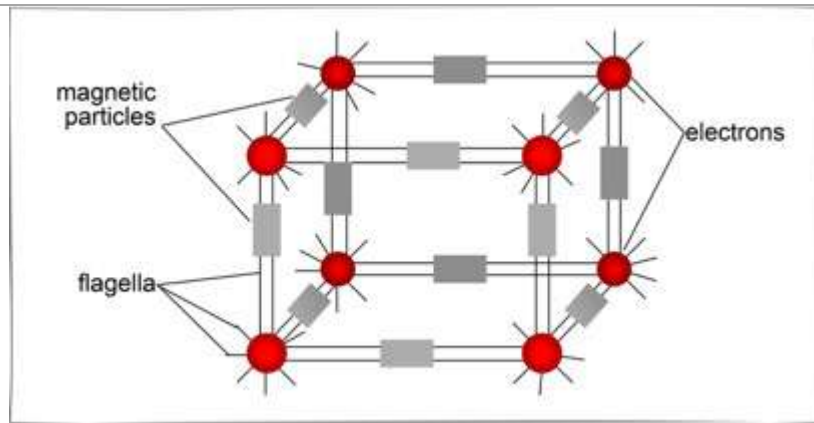

Crystal structure

Let's consider a vector diagram constructed from the binding neutron, which, as you remember, is in the Brain controlling all the "spare-parts" both in the system itself and in the anti-system that we already know about.

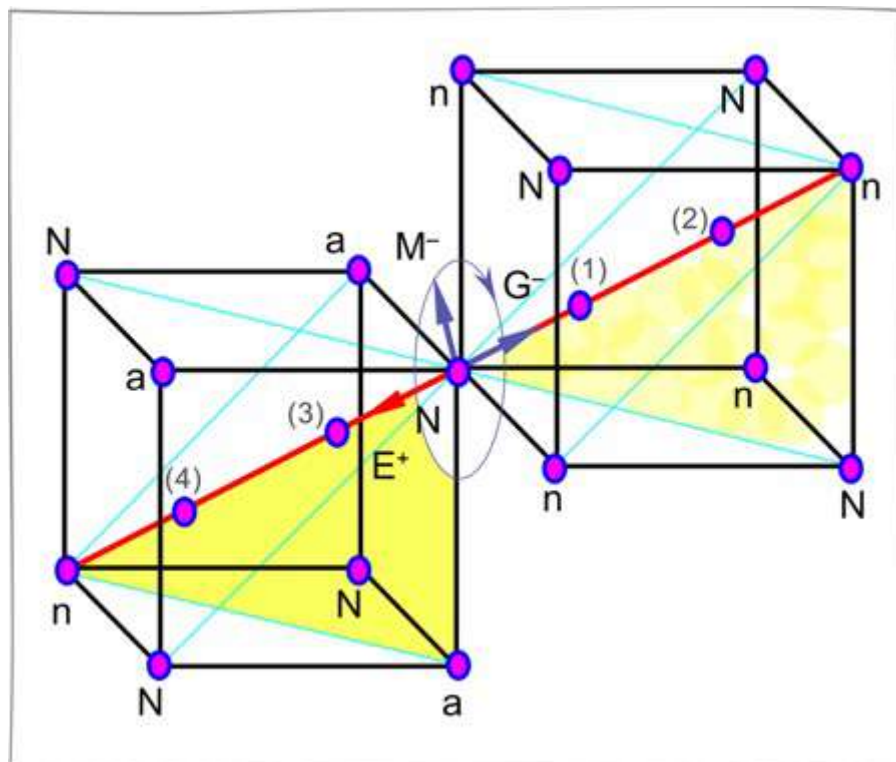

In the space of two sections, we have 17 masses, each of which has fields. The magnetic field of the system rotates clockwise with a period of $10^{7.5}$ years.

The figure shows the effect of the total gravitational field, it is directed away from the anti-system, in turn, the electric field (positive) is directed towards the anti-system. The weight of the entire system is composed of the weight of the elements included in the system. When adding modulo the weight of the system elements will be much higher than the weight when adding, with regard to the gravity axes direction.

For the Earth, the gravity vector is directed towards the Earth center, that is, the system is turned in such a way that the gravity vector is directed towards the Earth center. In this case, we get the curvature of the general gravitational field. This curvature changes as the Earth passes through the "jungle" of the vacuum structure, leaving a trace consisting of at least a hydrogen medium. On the one hand, the Earth loses part of its magnetic and electric fields while moving, but, on the other hand, the losses are compensated thanks to the Sun and other systems. The Solar system movement was considered in the previous books. So, when making the scheme of atoms combinations, it should be taken into account that the group of atoms (2) is the closest to the center of gravity, then the group of atoms (1), followed by the groups of atoms (3) and (4). The magnetic field of the system in which these groups of atoms are located rotates clockwise perpendicularly to the direction of the gravitational field (the gimlet rule). We should add that atom group (1) has a magnetic field with a rotation angle of **39,2°**, and atoms group (2) has a magnetic field with a rotation angle of **64,7°**. The rotation speed of magnetic fields is different; it is this rotation speed that determines the lifetime of the atoms group.

Based on the fact that for these two groups we have different rotation angles, the structures of the elements in the groups are different. For group (2), it is little and amounts to 38 structures (there cannot be a living cell from uranium). For group (1) the number of structures reaches 108 (Periodic Table). With changing the magnetic field the number of structures in groups changes. The magnetic field increase leads to the increase in the number of structures of atoms group (1) and to the decrease in the number of structures in group (2); for atoms group (2) this brings to the elements transmutation, and the level of the structure is getting lower. The balance is broken, and in the "invisible world" – with an increase in the magnetic field in the group of atoms (1) the number of structures in the group of atoms (3) increases, and with an increase in the magnetic field in atoms group (2) the number of structures in group (4) decreases, that is, there is a "swing", equilibrium of which determines the equilibrium system.

With an increase in the magnetic field for atoms group (1), the rotation of the magnetic field is accelerated (the lifetime shortens), the same for atoms group (2), but the lifetime for atoms group (3) and (4) is getting longer.

It is interesting to note *the magnetic field angle* for atoms group (1) for various animals, fish, and birds:

№	Name	Magnetic field angle (degrees)
1	Rats	36,4
2	Cockroaches	23,5
3	Elephants	63,6
4	Shark	22,5
5	Dinosaurs	12,5 *
6	Sparrow	23,5
7	Cross fish	35
8	Mammoth	11,2 *
9	Dolphin	36,6

In humans, the angle of the magnetic field is **39,2°**. Mammoths and dinosaurs became extinct not because of the Earth icing, but because of the sudden **INCREASE OF THE MAGNETIC FIELD ANGLE** of atoms group (1). In that distant time, changes in the fields made the angle of the magnetic field reach **35°** for biological objects, while the limit angle for mammoths was **14,2°**, and for dinosaurs **14,7°**.

The extinction rate was:

- ***mammoths – 0.5 years;***
- ***dinosaurs – 1.15 years.***

At present, the limiting angle of the magnetic field of atom group (1) for cockroaches is 58°, so their number will increase significantly (about 30 times), and mainly in the Ukraine, in the Baltic States, France, the USA (about which many newspapers loudly inform) and Africa.

In connection with an increase in the magnetic field and, as a consequence, an increase in the magnetic field angle of atoms group (1), there will be extinction of those biological objects, which slope of the magnetic field in the atoms group (1) 50% less than optimal.

In humans, the magnetic field angle in atoms group (1) is optimal; a deviation of up to 4% from this angle ensures normal exchange of information. The graph of the angle change in atoms group (1) is shown in the figure.

The following are dependencies on the main indicators state for man depending on the slope change of the magnetic field vector of atoms group (1). Experiments conducted by Dokuchaev V.I. confirmed that at the moment of bonds breaking between the groups (1, 2) and (3, 4), energy is released ("a turn" of the electromagnetic and gravitational fields).

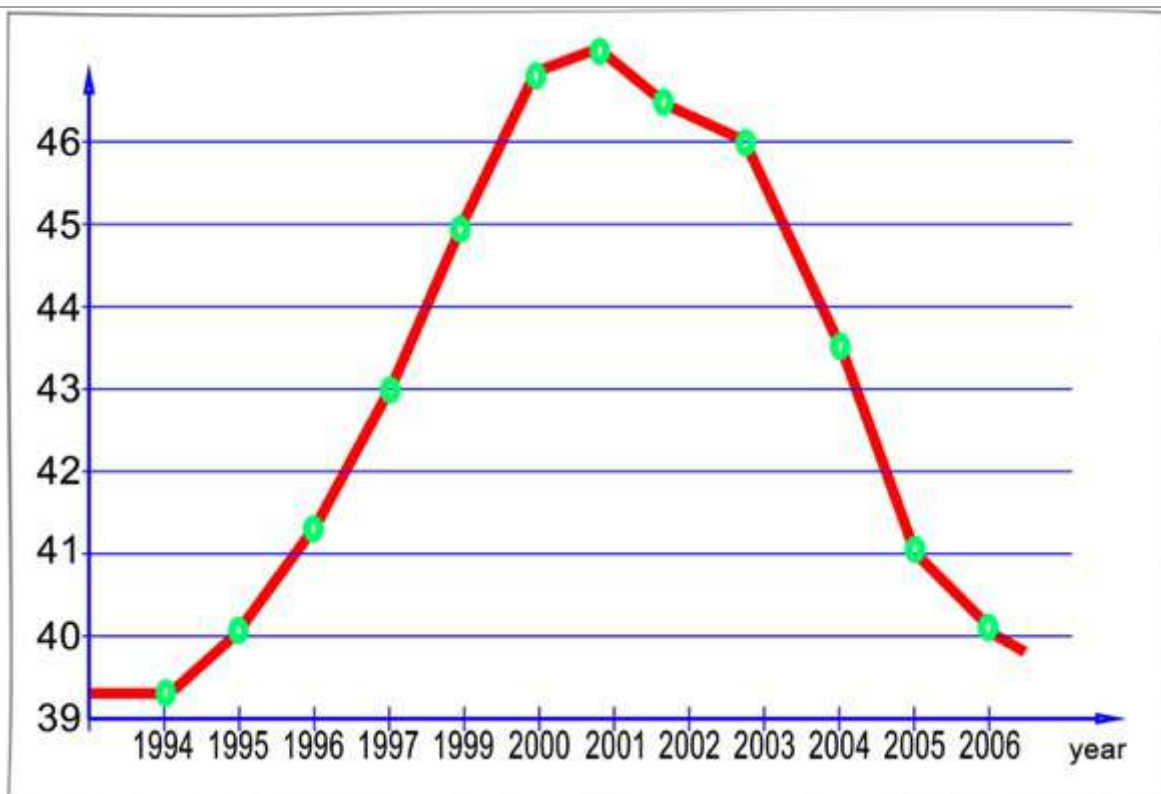

With the angle of the vector rotation of atoms group (1) to 41° , mental activity ceases, the connection with the "invisible world" is broken.

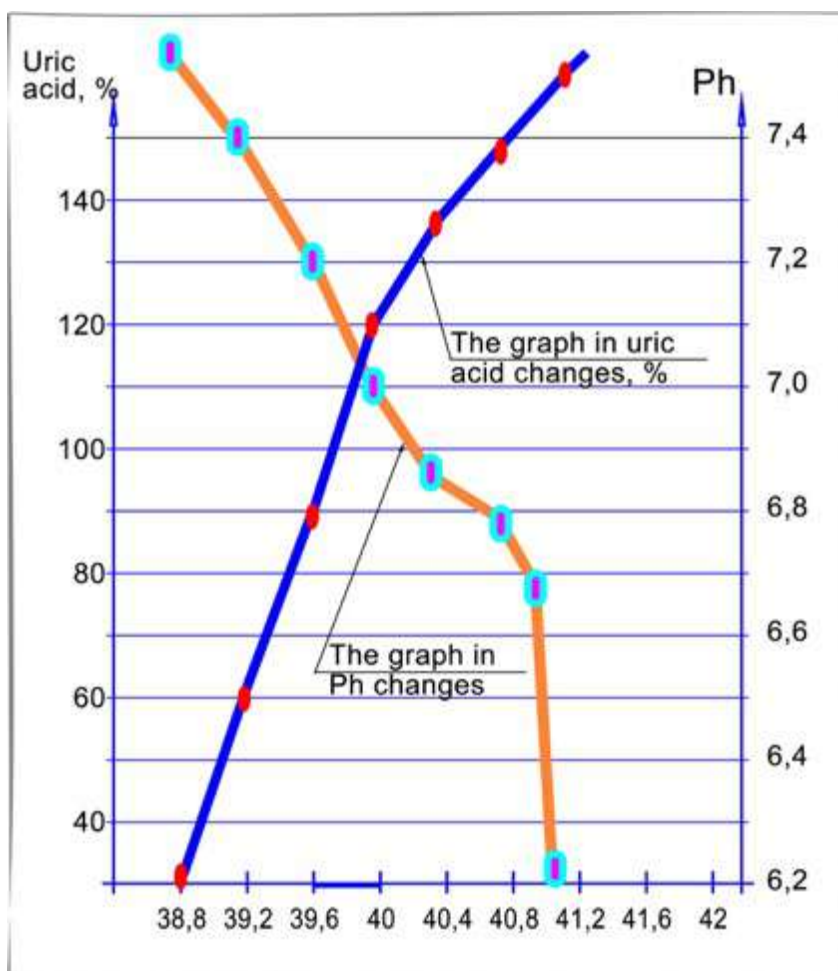

Graph of changes in uric acid and Ph (negative logarithm of the hydrogen ions concentration) in the blood. The angle of the vector rotation of atoms group (1). The norm of the parameter Ph is 7.4–7.35.

When reaching % uric acid in the blood

- **123% – the beginning of schizophrenia;**
- **133% – the beginning of neurasthenia;**
- **145% – the beginning of paranoia.**

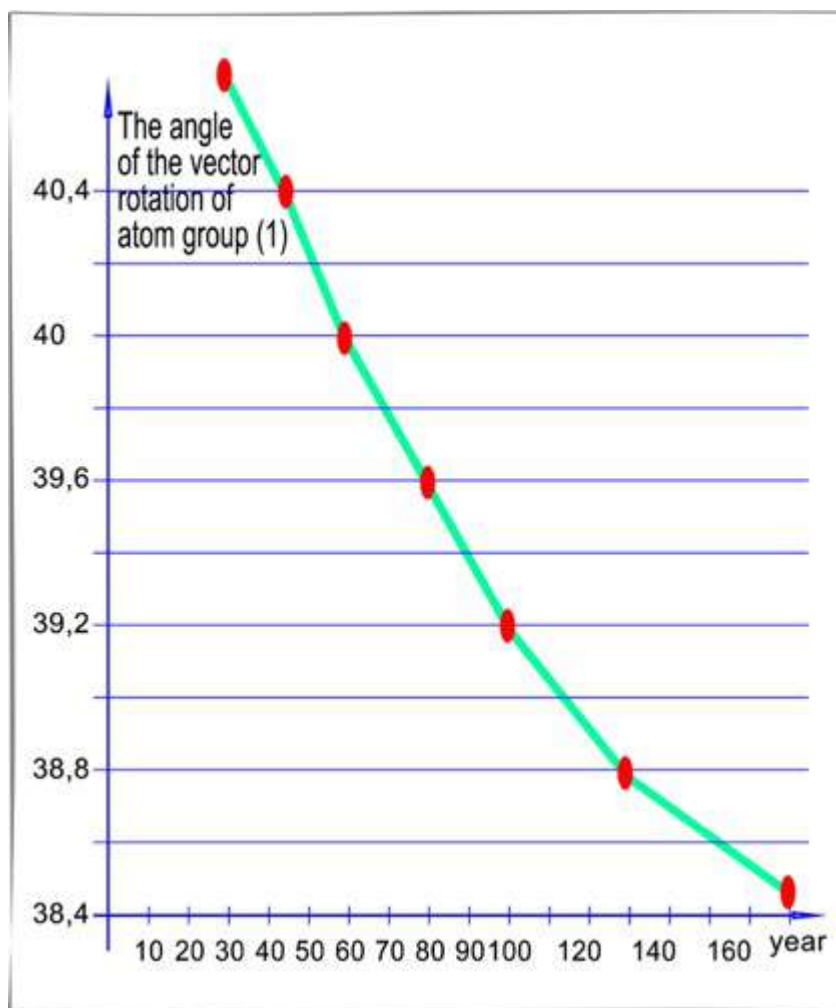

When the vector rotation angle of atoms group (1) changes (1), **the biological lifetime shortens** (the vector rotates faster). The graph of dependence of the biological lifetime with the change in the vector rotation angle of atoms group (1).

All this, at first glance, may seem rather complicated and rather improbable, but I will take you back to my first book, where initially, I said, as well as **A. Khatybov and N. Levashov**, that the hindrance is **IN OUR DEVELOPMENT** (and science development) today **IS THE WORLDVIEW**. Both we and science never want to part with our point of view on the material (and on the non-material world) which I call, just like

A. Khatybov – the "**Invisible world**") that have been knocked in our heads since birth, namely, **a solid body → liquid → gas → unorganized plasma**.

Atomic structures, naturally, are looked for in a solid body, for which they create synchrotrons, colliders, etc., never regretting for wasted money. But we already understand this and have a completely different point of view on the material (and non-material) world. **Strictly organized plasma → material structures (solid, liquid, gas)**. Atomic structures should be considered only in the upper octaves of plasma. As we already know from the previous books, the upper octave of the material structures is **64**. The range of **16, 22, 28, 32, 50, 54, 64 IS THE MATERIAL WORLD**. Currently, all man-made devices do not go beyond octave 32, which does not mean that this is the limit of our potentialities. **This is the limit of modern science and technology**. It should be remembered that **N. Tesla, N. Levashov, A. Khatybov** and some others, who are living today, worked and can work with **octave 60** and **ALREADY ON OTHER PHYSICAL PRINCIPLES**. Present science can work (and create technical devices) of no higher than octave **32**, but all types of instruments cannot be created above octave **64** to measure the characteristics of structures in octaves **128–66**.



All that is higher than octave **64** is **NON-INERTIAL MASS**, that is, there are no gravitational frequencies there. **THIS IS – "ILLUSION", the INVISIBLE WORLD**, a place where there exists and completely at ease –

the Soul, Spirit, Brain – whatever you please to call this "something". The basic atomic structure is octave 128 and, if it is "plucked", we will reach octave 64.

Until **2012**, the Control System (you can read about this in my first and second books) successively switched first to octave **224**, then to **512**. But already at the clock time interval of octave 224, the light speed is billions of times more. And this transition, as you know, was stopped, and therefore, after 2012, ***the "SvetL" Programs*** required changes in accordance with other parameters different from those that were implemented in ***the "SvetL" Complex Generators*** during the life of N. Levashov. He was well aware of this and unobtrusively, intelligently, as he used to do, "sent me to look for" something that was supposed to help me. This is how I "accidentally" got acquainted with the science of **A. Khatybov** and got an access to most of his non-public works.

So what was not allowed to be done after 2012 through the Program, when N. Levashov was gone? It was not allowed to increase the structure charge power, not knowing its characteristics. With the rise of the Brain existence octave, it became necessary to change the gravitational octaves, and this was already a matter of principle. From the old control system there remained a huge pile of everything, in which, it seemed, there was everything. Raking among that pile, there were found a lot of things used today by the native Control System. There was not only one thing – **THE THEORY OF THE GOLDEN SECTION**. From Pythagoras, they immediately jumped over to differential and integral numbers. There was no, as it turned out, the theory of prime numbers which are the basis for understanding all the processes on the Earth and all current transformations. Besides, there was no theory of Phyto-functions as the main function for the biostructures formation. All this "missing" and much more had to be found, calculations checked and applied in such a way that the created ***"SvetL" Programs***, interrelating with the User's Brain, could complement for the missing in today's Life Support System. It was extremely difficult, but it became possible, which is confirmed by the long-term use of the Programs.

Before proceeding to making possible constructions (according to this principle, ***the SvetL Programs*** are built) – constructions of atomic reactors; let us dwell on some geometrical figures, from which we will further make nuclear reactors.

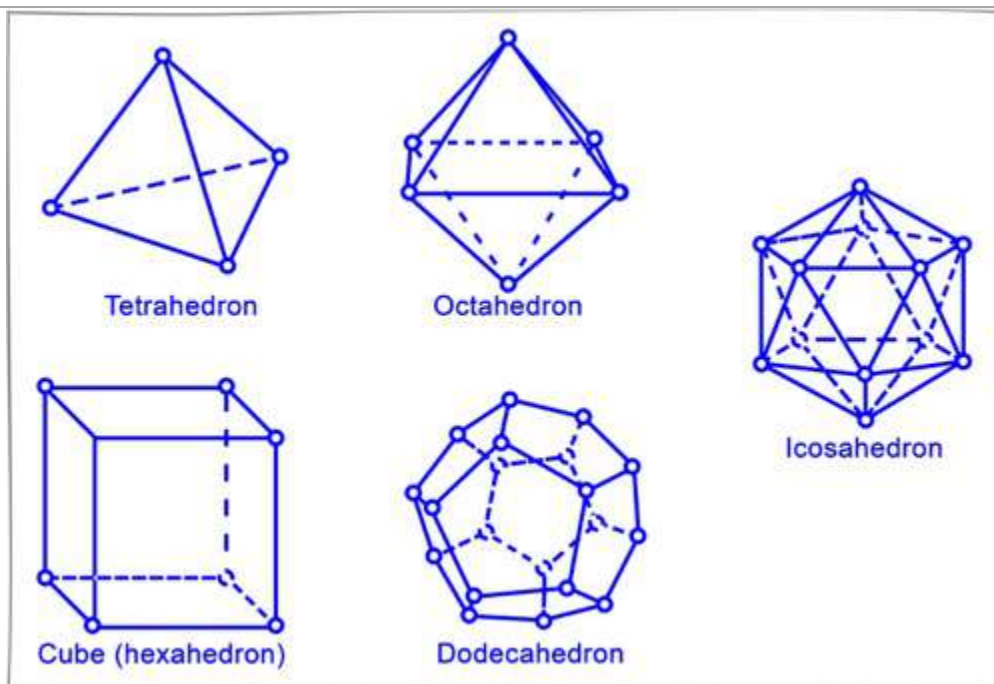

Five Platonic Bodies (full symmetry)

Many important and vital molecules exist in two forms. The famous 5 Platonic bodies are supplemented with the bodies of chiral symmetry: Rhombododecahedron, Chiron, Biocton, Granaton, Bipyramine.

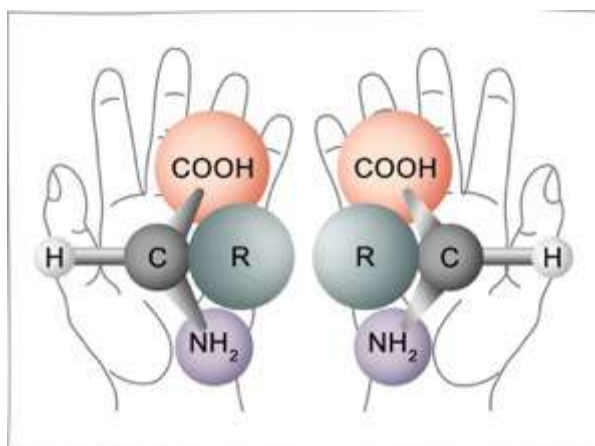

Chirality diagram

These two forms are chiralic, since their reflections in a perfect flat mirror cannot be combined. They relate to each other like the left and right hand. Therefore, this property is called **chirality** (from the Greek **cheir** – **hand**).

Possessing chiral symmetry, these constructions break general symmetry and, as a result, correct fields vectors.

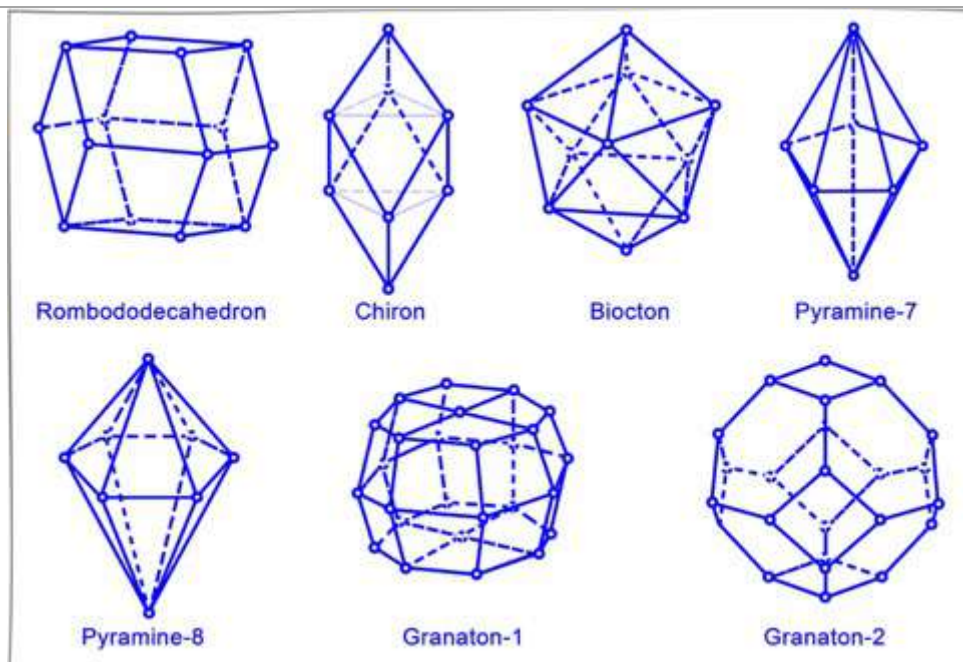

The properties of the above figures are indicated in the design part, they allow you to understand the design, for example, of the **"SvetL" Programs** using these figures. But first we give a sample of a **HYDROGEN BLOCK DESIGN OF A LIVING CELL**. Graphs, built on the basis of calculations, show strict conformity when building a system and are an additional justification for the structures formation.

Here is a table for an atom biomass and its "Soul" – Spirit (antiatom biomass).

N	Chemical element of group (1)	Varieties (isotopes, isobars, isosteres)	Number of atoms	Chemical element of group(3)	Varieties(isotopes, isobars, isosteres)	Number of atoms
1	H	2	4	He	1	8
2	He	1	8	Li	6	12
3	B	3	20	C	6	24
4	C	6	24	N	4	28
5	N	4	28	C	6	24
6	O	7	32	N	4	28
7	Ne	1	40	N	4	28
8	Na	4	44	Mg	4	48
9	Mg	4	48	Na	4	44
10	P	6	60	S	4	64
11	Ar	3	72	K	8	76
12	K	8	76	Ca	60	80
13	Ca	60	80	K	8	76
14	Sc	1	84	Ca	60	80
15	Mn	3	100	Fe	32	104
16	Fe	32	104	Mn	3	100
17	Cu	3	116	Fe	32	104

18	Se	8	136	Cu	3	116
19	Kr	1	144	Cu	3	116
20	Y	9	156	Kr	1	144
21	Xe	1	216	Y	9	156
22	Ba	9	224	Xe	1	216

The table allows you to make the first conclusion: the

"SOUL" – SPIRIT DOESN'T OXIDIZE (DOES NOT RUST)!

The second conclusion:

Both the cells of bioobjects and the "SOUL" – SPIRIT – ARE UNIQUE – we have 24 axes of symmetry (18 axes, 6 translations), from which, we get a unique symmetry if we remove **2** axes.

That is, the unique symmetry has 22 axes, and this is very important to take into account when distributing the information-command load in the Programs themselves. It is precisely according to this principle that the New Complex was designed today with the working title "**Construct Complex DI**", created to provide a real protection against plenty of negative phenomena that affect people (apartments, houses, cottages, etc.) in today's perestroika life support processes. So far – this is an experiment and testing in different region of residence of people. And I will tell you about it later in detail.

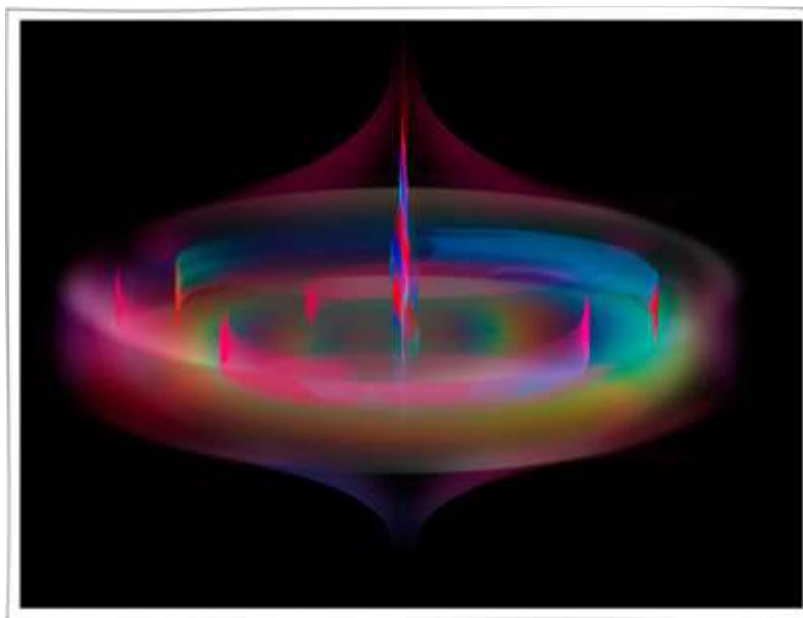

The work of the Generator "Complex DI" in the area of closed space

When the angle of the vector rotation of atoms group (1) is changed, there occurs the transmutation of chemical elements. The transmutation rate is determined by the slope of the vector.

"The Soul – Spirit" undergoes transmutation as a consequence.

Table of sequential transmutation of chemical elements of group (1)

N	Chemical element.	Transmutation (step 1)	Slope in vector degrees M
1	H	disintegrates	39,9
2	He	He \Rightarrow H	39,6
3	B	B \Rightarrow LiHe	40,2
4	C	C \Rightarrow LiH ₃	40,1
5	N	no transmutation	-
6	O	O \Rightarrow Li ₂ He	40,4
7	Ne	Ne \Rightarrow Li ₃ H	40,7
8	Na	Na \Rightarrow Li ₃ He	39,9
9	Mg	Mg \Rightarrow Li ₂ He ₃	40,3
10	P	P \Rightarrow Li ₄ H ₃	41,8
11	Ar	Ar \Rightarrow Li ₅ H ₃	40,2
12	K	K \Rightarrow Li ₆ H	40,2
13	Ca	Ca \Rightarrow Li ₆ He	39,7
14	Sc	Sc \Rightarrow Li ₆ H ₃	41,9
15	Mn	Mn \Rightarrow Li ₈ H	39,9
16	Fe	Fe \Rightarrow Li ₈ He	39,8
17	Cu	Cu \Rightarrow Li ₉ He ₂	40,8
18	Se	Se \Rightarrow Li ₁₁ H	40,9
19	Kr	Kr \Rightarrow Li ₁₁ H ₃	42,1
20	Y	Y \Rightarrow Li ₁₂ H ₃	40,2
21	Xe	Xe \Rightarrow Li ₁₇ H ₃	40,4
22	Ba	Ba \Rightarrow Li ₁₈ He	41,8

The structure of the binder is thus transformed into binders of blocks of 3 (lithium binders), which is viral. In general, 1.600.000 types of viruses can be formed.

An extraordinary possible combination of viruses (***everything that is harmful to humans***) presupposes existence of such a number of cell structures in which the corresponding “spectra” appear in completely different systems of the human body.

Completely different structures of atoms and anti-atoms form man’s race, his genetic code, a strict protection system

(filters), and only the transmutation of the protection system itself gives rise to the development of "viruses".

About 48 million designs of nuclear reactors can be built, on the basis of which a human organism is born according to the laws of form. N. Levashov did not write about it directly, but this, as a result, follows from the analysis of the book "**The Spirit and the Mind**", if, of course, it is read carefully and several times, because, as I have already mentioned, it is written in layers, and each reading reveals the reader more and more new knowledge.

Here are examples for the formative – hydrogen system. Note that all three hydrogen systems contain 108 compounds each, include signs of race, signs of separation according to civilizations (**8 civilizations**), as well as **MAN AND WOMAN DIVISION**. The appendix contains combined hydrogen tables.

Table of isotopes, isobars and isosters of the elements of atoms group (1)

N	Chemical element	The atoms number in the assembly of the element in relation to man	The element coinciding by the number of atoms
1	H	4, 5, 6	
2	He	8	
3	B	20, 21, 22, 23	
4	C	26, 28, 30	
5	N	28, 30, 32	
6	O	33, 35, 37, 39	F (isotope)
7	Ne	40	
8	Na	44, 46, 48	
9	Mg	49, 51,	
10	P	60, 62, 64, 66	S
11	Ar	73, 75	
12	K	76, 78, 80, 82, 84	Ca, Sc
13	Ca	81, 85, 87, 89, 91, 93, 95, 97, 99, 101, 103, 105, 107, 109, 111, 117, 123	Isotopes Sc, Ti, V, Cr, Mn, Fe, Co, Cu, Zn
14	Sc	84	
15	Mn	101, 103	
16	Fe	104, 106, 108, 110, 112, 114, 116, 118, 120, 124, 128, 132, 136	Co, Ni, Cu, Zn, Ga, Ge, As, Se
17	Cu	116, 118,	
18	Se	136, 138, 140, 142, 144	Br, Kr
19	Kr	144	
20	Y	156, 158, 160, 162, 164	Zr, Nb
21	Xe	216	
22	Ba	224, 226, 228, 230, 232	La, Ce

The element "**Ba**" varieties include a group of lanthanoides⁷⁰.

On the right of the table there showed chemical elements similar in the number of atoms, but the properties of them are of the main group, that is, in the right column there are isosters. What is taken for **La** is the isoster of **Ba**.

Before proceeding to the structures analyses and the elements design, we determine the composition of elements in group (2), since without this group, as well as without detailed consideration of the structure of the "**Soul**" – **Spirit**, we cannot talk about the complete scheme (equilibrium) of one element. Group (4) is not important for "our" space; it (this group) is leading in the "invisible world" and will be considered only when designing vectors of magnetic, electrical and gravitational fields of the structures, and also as an addition to the atom-antiatom biological scheme that was very important in the adjusting of *the "SvetL" Programs*. When group (1) exists, the presence of atoms group (2) is optional. Atoms group (2) is the "garbage collector" of the structure. The so-called "residuesness" of the body is determined by the presence of "garbage" – formation of atoms group (2). "Residues" change the bio-system magnetic field, **REDUCING THE LENGTH OF LIFE** and causing transmutation of atoms group (1). The appearance of Li groups is a consequence of residuesness. I remind you here that the magnetic field vector of atoms group (2) has a rotation angle of **64,7°**.

When we in one way or another "touch" the matter of fields, we touch the product of the world-wide technological process that has passed strict and uncompromising control on the stability of properties and dimensions. However, all this is so very far from what people are able to create today, that the task of approximation it is too early to set so far. You cannot will success. For the time being, it is possible to set the task of understanding – in some distant future. But even today this is more than enough in order to move forward and create something similar to *the "Complex DI"*, and most

⁷⁰ Lanthanoids (from lanthanum and Greek. Eidos – image, type), lanthanoids, a family of 14 chemical elements with an autonomous number from 58 to 71, located in the 6th period of the Mendeleev system following Lanthan. Lanthanides and similar elements of scandium, yttrium, and lanthanum form a group of rare-earth elements. This name is explained by the fact that all these elements are rare and give refractory, water-insoluble oxides, in the old terminology, – "earth". Rare earth elements are included in a secondary subgroup of Group III of the periodic system.

importantly, improve **the "SvetL" Programs** in this direction. **So the slogan: "CLEAN YOUR CELLS"** not only makes sense, but is also necessary, which, in fact, the Brain begins to deal with and control the process itself interrelating with the applied Programs.

6.4. As the products, so the thoughts

When filling the biosystems structures – of atoms group (2) with "garbage" by only **6.2%** – and the biosystem gets 100% of residues.

"Residuesness" causes formation of cancer cells. The angle of the magnetic field vector rotation of the "garbage" group of atoms for a cancer cell is $40,3^\circ$.

Each element collects its own "garbage" and "lays it by in its own basket". On the other hand, this "garbage" is "fat accumulation", where atoms group (1) "feeds up" from. These are the so-called "winter stocks", and each atoms group (1) makes them, but one likes carrots, the other likes cabbage, so each atoms group makes its own "garbage". If atoms group (1) "is made to eat" a different chemical element from the one supposed to "be stocked", the system gets imbalance. Now the whole group is called a "cancer group of atoms". The only way to fight with this group is to change the vector slope and transfer unnecessary "garbage" to the "fat reserves". However, not every Brain, controlling the process, is able to do it.

"To make the group eat" an unnecessary or "unusual" for the storage element **ONLY EXTERNAL INFLUENCES – electric, magnetic, gravitational fields, neutrino and antineutrino flows – ARE ABLE.**

Under the conditions of external influence the group of atoms has no protection. The only possibility is to run away and "transfer one's condition" or in other words, "run away to the invisible world"- to transfer an excess of the electric field to the anti-world. However, this excess causes a crisis in the "invisible world", and the swing begins to work – gangster formations under the guise of the gravitational field are sent back which "rob" and take away the fields.

In such processes, **the "SvetL" Programs** can only help the Brain to realize a supporting role in a certain time interval. The wish of man to get rid of cancer by applying **the "SvetL" Programs** installed on the Bracelet

Generator, for example, will not bring to the desired result. **The "SvetL" Complex** will be able to make the so-called "remaining time" longer and painless (which is very important), but it is not a panacea in this fight. Only my personal "efforts" with direct "reliance" on the potentialities of N. Leveshov's Generator, transferred from France, and **the "SvetL" Complex** help in most cases (but, unfortunately, not 100%) gave a positive result. Of course, work in this direction is underway, but how long it will take to solve this problem, I can't say today. Here we have to take into account a great number of new factors that have emerged and regulate it, on the one hand, through a new life support system, and on the other hand, considering the leveling of the whole of balance in the future life and the existence of people and the events taking place in this direction actually, told in the previous four books. Below I am describing the way I am going, relying on the most complicated calculations of A. Khatybov.

**The biosystem "storage" table
or what an atoms group (2) is capable of**

N	Chemical element	«Garbag», or «winter stocks»	Number of atoms of «garbage»	Varieties	List of varieties (number of atoms)	Element coinciding by the number of atoms
1	H	H	4	1		
2		He	8	4	10, 12	Li
3		Be	16	2	18	
4		B	20	6	22, 24, 26	C
5		C	24	6	25	

Under normal conditions, group of **Li** atoms doesn't find the way to "the storage" – it is "inedible", but this element under the "alien roof", or "under the guise" of **He**, crawls to the storage. In addition, there is no place "in the storage" for oxidizing agents – **O** and **F** groups of atoms; there is no access for **N** group of atoms (no additional parties to be formed – DNA, one-party system – in the general structure). Carbon (**C**) enters the "storage" as an isoster and "under the mask" of element **B**. Despite the coincidence of the number of atoms, the structural gratings of isosters, isotopes, and isobars are different.

Let's consider the "soul" of the structure called hydrogen. With all this, it is necessary to take into account what is in the "storage" – **Like the products, like the thoughts**. In the table, we additionally note the vector deviation angle of atoms group (1) depending of the "products" of atom group (2) in the equilibrium state of the external fields.

**Table of the "Soul" – hydrogen structure
(in atom group (1) there is a hydrogen block – H)**

N	N	Element of atoms group (2)	Element of atoms group (3)	Number of atoms group (3)	Vector rotation angle of atoms group (1), degrees	The atom analogue on the periodic table
1	1	H	H	4	32,5	
2			He	10	36	
3			He	12	36,4	Li
4			Be	18	38,8	
5			B	22	39,2	
6			B	24	42	O
7			B	26	44,6	
8			C	25	45,5	
9	2	He ₁₀	H	5	12,5	
10			H	7	12,8	
11			He	10	24	
12			He	12	23,2	Li
13			Li	14	34	
14			Li	16	45	Be
15			Li	18	60	
16			N	29	11,6	
17			N	31	12	
18			Ne	42	23,4	
19			Mg	50	34	
20			P	62	48	
21			Ar	73	52	
22			Kr	145	16	
23			Kr	147	23,6	
24			Xe	218	32	
25			Ba	232	44	Ce
26			Ba	234	46	
27			Ba	236	48	Pr
28	3	He ₁₂	H	4	11,2	
29			H	6	22,2	
30			H	8	32	He
31			He	9	34	
32			He	11	36	
33			Li	13	50	
34			Li	15	54	
35			Li	17	58	
36			N	29	25,2	
37			N	31	33,8	
38			Ne	42	11,5	
39			Mg	49	45	
40			Mg	51	54	
41			P	61	78	
42			Ar	72	33,4	

43			Ar	74	44,5	
44			Kr	144	50	
45			Kr	146	60	
46			Kr	148	70	Rb
47			Xe	217	53,2	
48			Xe	219	66	
49			Ba	232	12,4	Ce
50			Ba	234	25	
51			Ba	236	45	Pr
52	4	Be ₁₈	H	5	34	
53			H	7	44	
54			He	10	46	
55			He	12	53,4	Li
56			Li	13	66	
57			Li	15	74	
58			Li	17	88	
59			Be	17	35	
60			N	30	26,2	
61			N	32	34,5	O
62			Ne	41	47,4	
63			Mg	49	62,4	
64			Mg	51	66,2	
65			P	61	62,2	
66			Ar	73	55	
67			Kr	146	48	
68			Kr	148	52	Rb
69			Xe	217	23,2	
70			Xe	219	34	
71			Ba	231	44	
72			Ba	233	51,6	
73			Ba	235	60,6	
74	5	B ₂₂	H	5	12,8	
75			H	7	20	
76			He	9	30	
77			He	11	40	
78			Li	14	34	
79			Li	16	45,2	Be
80			Li	18	62,2	
81			Be	17	54,4	
82			N	28	33,6	
83			N	30	45	
84			N	32	54	O
85			Ne	40	53,5	
86			Ne	42	65	
87			Mg	49	53	
88			Mg	51	56	
89			P	61	64	
90			Ar	73	44	

91			Kr	145	55	
92			Kr	147	64	
93			Xe	216	45	
94			Xe	218	50	
95			Ba	232	65	Ce
96			Ba	234	75	
97			Ba	236	88	Pr
98	6	B ₂₄	H	5	12,4	
99			H	7	22,5	
100			He	9	15	
101			He	11	34	
102			Li	14	46,4	
103			Li	16	58,4	Be
104			Li	18	70,4	
105			Be	17	46	
106			N	28	37	
107			N	30	46	
108			N	32	55	O
109			Ne	40	56	
110			Ne	42	65	
111			Mg	49	55	
112			Mg	51	64	
113			P	61	66	
114			Ar	73	61	
115			Kr	145	54	
116			Kr	147	62	
117			Xe	216	70	
118			Xe	218	78	
119			Ba	232	52	Ce
120			Ba	234	58	
121			Ba	236	64	Pr
122	7	B ₂₆	H	6	12,8	
123			H	8	25,5	He
124			He	10	44	
125			He	12	52	Li
126			Li	13	55	
127			Li	15	64	
128			Li	17	73	
129			Be	17	64	
130			N	29	36	
131			N	31	38	
132			Ne	41	48	
133			Mg	49	55	
134			Mg	51	60	
135			P	61	62	
136			Ar	72	40	
137			Ar	74	45	
138			Kr	145	55	

139			Kr	147	57	
140			Xe	217	62	
141			Xe	219	64	
142			Ba	231	66	
143			Ba	233	72	
144			Ba	235	78	
145	8	C ₂₅	H	5	21,5	
146			H	7	27,5	
147			He	9	36	
148			He	11	38	
149			P	61	62	
150			Ar	74	70	
151			Kr	145	75	
152			Kr	147	82	

The obtained table possesses **THE COMPLETE SET OF CELLS OF LIVING MATTER** with the formative of hydrogen (in group (1) – hydrogen). Atoms group (4) is not formed.

Table of belonging of hydrogen groups to man (sample from the previous table)

The last column indicates the type of civilization inhabiting the Earth.

N of hydrogen block for man	N from the complete system of hydrogen blocks														Type of civilization
		A	B	C	D	E	F	G	H	I	J	K	L	M	
1	1	+	+	+	+	+	+	+	-	-	-	-	-	-	7
2	2	+	-	+	-	-	-	-	-	+	-	-	-	-	6
3	3	+	-	-	+	-	+	-	-	+	-	-	-	-	5
4	4	+	+	-	-	-	-	-	-	+	-	-	-	-	4
5	5	+	-	+	+	-	+	+	-	-	-	-	-	-	3
6	6	+	+	-	-	-	-	+	-	-	-	-	-	-	2
7	7	+	+	+	+	-	+	-	-	+	-	+	-	-	1
8	8	+	-	-	-	+	-	-	+	-	-	-	+	-	0
9	9	+	+	-	-	-	-	-	+	-	-	+	-	-	7
10	10	+	-	+	+	-	+	-	+	-	-	+	-	-	6
11	11	+	+	-	-	-	-	-	-	+	-	-	-	-	5
12	12	+	-	+	-	-	-	-	-	+	-	-	-	-	4
13	16	+	+	-	-	-	-	+	+	-	-	-	-	-	2
14	17	+	+	-	-	-	+	+	+	-	-	-	-	+	1
15	18	+	-	-	-	+	-	+	+	-	-	+	-	-	0
16	19	+	+	-	-	-	-	+	+	-	-	+	-	-	4
17	20	+	-	+	-	-	-	+	+	-	-	-	-	-	6
18	21	+	-	-	-	+	-	+	-	-	-	+	-	-	0
19	22	+	+	+	+	-	+	-	-	+	-	-	-	+	5
20	23	+	+	-	-	-	-	-	-	+	-	-	-	+	4
21	24	+	-	+	-	-	-	+	-	-	+	-	-	-	5

22	25	+	+	-	-	-	-	+	-	-	+	+	+	+	7
23	26	+	-	+	-	-	-	+	-	-	+	+	+	+	3
24	27	+	-	-	+	-	+	+	-	-	+	+	+	+	1
25	28	+	+	-	-	-	-	+	+	-	-	-	-	-	7
26	29	+	-	+	-	-	-	+	+	-	-	-	-	-	6
27	30	+	-	-	+	-	-	+	+	-	-	-	-	-	5
28	31	+	-	-	-	-	+	+	+	-	-	-	-	-	4
29	32	+	+	-	-	-	-	+	+	-	-	-	-	-	2
30	36	+	-	+	-	-	-	+	-	-	-	-	-	-	1
31	37	+	-	-	-	+	-	+	-	-	-	-	-	-	0
32	39	+	+	-	-	-	-	+	-	-	-	-	-	+	2
33	40	+	-	+	+	-	+	+	-	-	-	-	-	+	1
34	41	+	+	-	-	-	-	+	-	-	-	-	-	-	7
35	42	+	-	-	-	+	-	+	-	-	-	-	-	-	0
36	43	+	+	-	-	-	-	+	-	-	-	-	-	-	2
37	44	+	-	+	-	-	-	-	-	+	-	-	-	+	3
38	45	+	-	-	+	-	+	+	-	-	-	-	-	-	1
39	46	+	-	-	-	+	-	+	-	-	-	-	-	-	0
40	52	+	+	-	-	-	-	+	-	+	-	+	-	+	7
41	53	+	-	+	-	-	-	+	-	+	-	+	-	+	5
42	54	+	-	-	+	-	-	+	-	+	-	+	-	+	2
43	55	+	-	-	-	+	-	+	-	+	-	+	-	+	0
44	60	+	+	-	-	-	-	+	-	-	-	-	-	-	7
45	61	+	-	+	-	-	-	+	-	-	-	-	-	-	4
46	62	+	-	-	+	-	+	+	-	-	-	-	-	-	1
47	63	+	+	-	-	-	-	+	-	-	-	-	-	-	4
48	64	+	-	+	-	-	-	+	-	-	-	-	-	-	5
49	65	+	+	+	+	-	+	-	+	+	-	+	+	+	4
50	66	+	-	-	-	+	-	-	-	+	-	-	-	+	0
51	67	+	+	-	-	-	-	+	-	-	-	-	-	-	1
52	68	+	-	+	-	-	-	+	-	-	-	-	-	-	4
53	74	+	+	-	-	-	-	+	-	-	-	+	-	-	7
54	75	+	-	+	-	-	-	+	-	-	-	+	-	-	6
55	76	+	-	-	+	-	-	+	-	-	-	+	-	-	5
56	77	+	-	-	-	-	+	+	-	-	-	+	-	-	4
57	81	+	+	-	-	-	-	+	-	-	-	+	-	-	2
58	82	+	-	+	-	-	-	+	-	-	-	-	-	-	6
59	83	+	-	-	+	-	-	+	-	-	-	-	-	-	4
60	84	+	-	-	-	-	+	+	-	-	-	-	-	-	6
61	85	+	-	-	-	+	-	+	-	-	-	-	-	-	0
62	86	+	-	-	-	+	-	+	-	-	-	-	-	-	0
63	87	+	+	+	+	-	+	+	-	+	+	+	-	+	3
64	88	+	+	-	-	-	-	+	-	+	+	+	-	+	4
65	89	+	+	+	+	-	+	+	-	-	-	-	-	-	1
66	90	+	-	-	-	+	-	+	-	-	-	-	-	-	0
67	91	+	+	-	-	-	-	+	-	-	-	-	-	-	3
68	92	+	-	+	-	-	-	+	-	-	-	-	-	-	4
69	95	+	-	-	+	-	+	-	-	+	-	+	-	+	5
70	96	+	-	-	-	+	-	-	-	+	-	+	-	+	0
71	97	+	+	-	-	-	-	-	-	+	-	+	-	+	1

72	98	+	+	-	-	-	-	+	-	-	-	-	-	7
73	99	+	-	+	-	-	-	+	-	-	-	-	-	6
74	100	+	-	-	+	-	-	+	-	-	-	-	-	5
75	101	+	-	-	-	-	+	+	-	-	-	-	-	4
76	105	+	+	-	-	-	-	+	-	-	-	-	-	1
77	106	+	+	-	-	-	-	+	-	-	-	-	-	7
78	107	+	-	+	-	-	-	+	-	-	-	-	-	5
79	108	+	-	-	-	+	-	+	-	-	-	-	-	0
80	109	+	-	-	-	-	+	+	-	-	-	-	-	1
81	110	+	+	-	-	-	-	+	-	-	-	-	-	1
82	111	+	+	-	-	-	-	+	-	+	-	+	-	5
83	112	+	-	+	-	-	-	+	-	+	-	+	-	2
84	113	+	+	-	-	-	-	+	-	-	-	-	-	7
85	114	+	-	+	-	-	-	+	-	-	-	-	-	6
86	115	+	-	-	+	-	+	-	+	-	-	-	-	1
87	116	+	-	-	-	+	-	-	+	-	-	-	-	0
88	119	+	+	-	-	-	-	-	+	+	+	+	-	7
89	120	+	-	+	-	-	-	-	+	+	+	+	-	4
90	122	+	+	-	-	-	-	+	-	-	-	-	-	7
91	123	+	-	+	-	-	-	+	-	-	-	-	-	6
92	124	+	-	-	+	-	-	+	-	-	-	-	-	5
93	125	+	-	-	-	-	+	+	-	-	-	-	-	4
94	130	+	+	-	-	-	-	+	-	-	-	-	-	7
95	131	+	-	-	-	+	-	+	-	-	-	-	-	0
96	133	+	+	+	+	-	+	+	-	+	-	+	-	2
97	134	+	-	-	-	+	-	+	-	+	-	+	-	0
98	135	+	+	+	+	-	+	+	-	-	-	-	-	5
99	136	+	-	-	-	+	-	+	-	-	-	-	-	0
100	138	+	+	+	+	-	+	+	+	+	-	+	-	5
101	139	+	+	-	-	-	-	+	+	+	-	+	-	1
102	142	+	-	+	-	-	-	-	+	+	-	+	-	4
103	143	+	-	-	+	-	+	-	+	+	-	+	-	1
104	147	+	+	-	-	-	-	-	+	-	+	-	-	7
105	149	+	-	+	-	-	-	+	-	+	-	-	+	6
106	150	+	-	-	-	+	-	+	-	+	-	-	+	0
107	151	+	+	-	-	-	-	-	+	-	-	-	+	1
108	152	+	-	-	-	+	-	-	+	-	-	-	+	0

A – belongs to man (regardless of race, nationality);

B – white race;

C – black race;

D – yellow race;

E – a "unique class" – the Jews;

F – red race;

G – enters the brain structure;

H – enters the spinal cord;

I – is included in the liver structure;

J – nervous system;

K – blood structure;

L – lymphatic system.

Psychological features of civilizations are described quite well in **D. Swift's "Gulliver's Journey"**.

In fact, the famous book by Jonathan Swift is called quite differently: **"Journeys to some distant countries of the world in four parts: the work by Lemuel Gulliver, first a surgeon, and then a captain of several ships"**. Jonathan Swift can be safely called a clairvoyant – in Gulliver's Journey, he mentions two satellites of the planet Mars, which were discovered much later than his book came out, **as late as the 19th century**.

The frequency characteristics of civilizations I gave. The table opens amazing group peculiarities.

Firstly, the group **E** does not have a phosphorus binder in the anti-atom, instead of this element – as a rule, there is an element **Ar**. This means (see the table) that **THERE IS NO INDEPENDENT THINKING PROCESS IN THIS GROUP**, and information is collected from neighboring groups having phosphorus in an anti-atom, and the “removed” information is given out to be one’s own.

Secondly, the gene pool is built on nitrogen (**N**). Group **E** uses someone else's gene pool, which accounts for the degeneration of this group with marriages within the group. You probably already read about this in various literary sources describing the life and work of the "Jewish people". The gene pool itself is stored in an anti-atom, leaving a trace in an atom.

Thirdly, the characteristic features of various races are singled out.

The following table shows average values for the vector slope of atoms group (1) in degrees, depending on the blood group and rhesus Rh-factor:

Group	Rhesus (Rh) factor plus				Rhesus (Rh) factor minus			
	I	II	III	IV	I	II	III	IV
B	39,1	39,3	39,5	39,9	39,0	39,2	39,8	40,0
C	39,3	39,5	39,8	40,1	39,2	39,4	40,0	40,4
D	39,4	39,7	40,0	40,3	39,4	39,9	40,2	40,6
F	39,4	39,8	40,2	40,6	39,4	39,7	40,0	40,3
E	39,6	40,0	40,4	40,8	39,4	39,9	40,4	40,9

If we compare with the graph of changes in the vector rotation angle of group (1) and the attendant "miracles", then you can consistently indicate the outcome or forthcoming events in today's realities – the closer to the critical point (for example, blood group IV, negative Rh factor), **THE FASTER WILL CEASE** the existence of this subject on the Earth. The table also shows the sequence of passing away.

This is one of the basic problems that faced me when creating Programs that could allow "slowing down" this objective process (if, of course, to get rid of emotions and "turn on" the Mind). All this was done in line with the ***Program of development of the proto-energy biogenesis of the flesh within the framework of cosmic anthropoecology***. (As I mentioned earlier – you should remember this name). All that is predetermined for the life on the Earth, all eight stages of its future development (and now only the first stage is under way) is being reconstructed: what the Earth has been invested, including everything on it and in it. This work regarding the correction and addition to the Programs could be started after ***January 19, 2015***, and was started then And only after ***nearly 3 years***, it became possible to make significant corrections, thus increasing the "possibilities" for specific representatives of the known genotypes, as well as, basing on what was known, create and start testing a completely new design of N. Levashov' Generator with a new "Software", which working name is "**Construct Cupola DI**".

Well, let's go further in our knowledge. There are a few more key points that are very important not only for the "**SvetL**" Programs, but also for a general idea of the main products of our thoughts.

Distinctive features of men and women

N	N	Element of atoms group (2)	Element of atoms group (3)	Vector rotation angle of atoms group (1), degrees	Man	Woman	Civilization	Genetic code record
1	1	H	H	32,5	+	-	7	-
5			B	39,2	-	+	3	-
7			B	44,6	+	+	1	-
8			C	45,5	-	+	0	+
11		He ₁₀	He	24	-	+	5	-
16			N	11,6	+	+	2	-
17			N	12	+	+	1	-
20			P	48	+	-	6	-
22			Kr	16	-	+	5	-
26			Ba	46	+	+	3	-
28	3	He ₁₂	H	11,2	+	-	7	-
36			N	25,2	+	+	1	-
39			Mg	45	+	+	2	-
41			P	78	+	-	7	-
42			Ar	33,4	-	+	0	-
52	4	Be ₁₈	H	34	+	-	7	-
60			N	26,2	+	+	7	-
63			Mg	62,4	+	+	4	-

65			P	62,2	+	-	4	-
74	5	B ₂₂	H	12,8	+	-	7	-
82			N	33,6	+	+	6	-
87			Mg	53	+	+	3	-
89			P	64	+	-	1	-
91			Kr	55	-	+	3	-
98	6	B ₂₄	H	12,4	+	-	7	-
106			N	37	+	-	7	-
111			Mg	55	+	+	5	-
113			P	66	+	-	7	-
119			Ba	52	+	+	7	-
122	7	B ₂₆	H	12,8	+	-	7	-
130			N	36	+	-	7	-
133			Mg	55	+	+	2	-
135			P	62	+	-	5	-
138			Kr	55	-	+	5	-
142			Ba	66	+	+	4	-
147		C ₂₅	He	36	+	+	7	-
149			P	62	+	-	6	-
151			Kr	75	-	+	1	-

Here, as an example, a white race is considered. It is of interest to note that the genetic code of O civilization is recorded only in women. In addition, women are not related to the informative part (there is no phosphorus in the "Invisible World"), information is recorded by reading from a "neighbor".



This, probably, accounts for the most extensive all round curiosity of a white race woman (for women of other races, this process is either inhibited or much lower).

From the above calculations and tables there follows a certain **CONSTRUCTION OF A LIVING SYSTEM – OF HUMAN** (mutations complement this scheme). Let me remind you that all 3 tables – of 108 "nuclear reactors" – the "heavier" atoms group (3), the larger the rotation angle of the magnetic field vector of atoms group (1). The gravitational field of atoms group (3) makes the magnetic field vector of atoms group (1) turn up to the limit value. The limiting values of the magnetic field vector angle of

atoms group (1) **ARE CLASSIFIED AS THE ELEMENTS OF THE LIVER AND BLOOD**, so minor fluctuations in the external magnetic field can cause irreversible changes in the liver and blood. For clearness, here is a drawing made by A. Luchin, which explains the above.

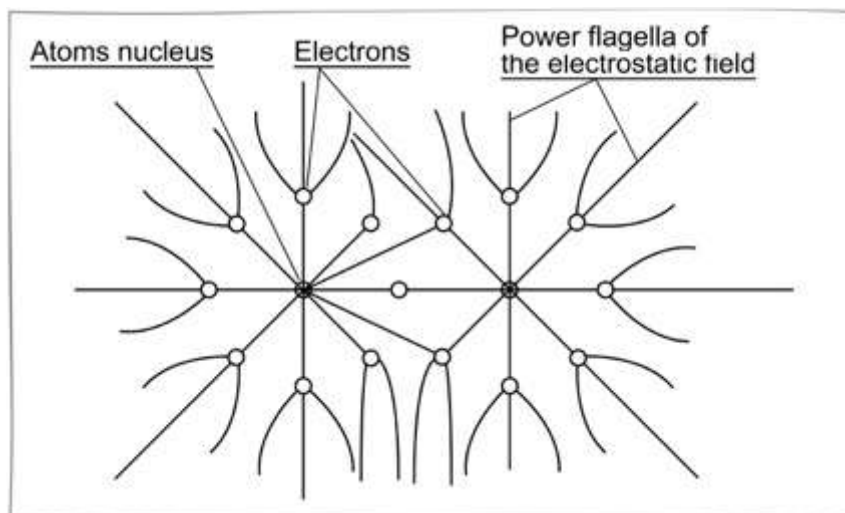

Blood is characterized by the following factors – the negative logarithm of the hydrogen ions concentration (**Ph**) and containing of uric acid. When a certain limit is violated and the bonds are broken, there occurs a chain reaction of transmutation of "nuclear reactors", and, as a result, the organism's death. This can be corrected by the Brain only, if, of course, its attention is drawn to the fact that, for some reason, (and there may be a lot of them) it "let it slip". Programs can cope with it today. Moreover, there are recorded and reliable results in this direction.

The spinal cord, brain and nervous system are formed only by **STRICTLY SPECIFIED GROUPS** of "nuclear reactors", which are different for both different races and civilizations, and this is an obstacle for performing organ transplants from one person to another.

The same problem with blood transfusions. Every man has his own blood. Only sisters of one civilization or brothers can be close in blood composition (at the same time, a sister cannot donate blood to her brother, and vice versa). Any blood transfusion – and there starts up a filter system. If the system does not have time to work, a viral group is formed, which, under favorable conditions, "attacks" the body.

As an urgent or temporary measure, blood transfusion is used, but only with fixed field "traps" that do not allow "foreign nuclear reactors" to pass through. It should be noted that blood in the human body has

protection, and no extraneous "nuclear reactor" can penetrate through this protection. In the blood "bank" intended for transfusion, there is no such protection, and blood transfusion directly into the system can cause a variety of reactions and bring to the emergence of new viruses (the difference in the slope of the magnetic field vector of the same group of atoms will lead to the formation of either mutant with an entry in the genetic code, or a new virus because of the transmutation of one of the groups of atoms).

Besides, blood transfusion **RESULTS IN MAN'S LIFE SHORTENING**, since donor blood always has the vector slope of atoms group (1) more than one's own blood. Can such a situation "be regulated" by the Brain, which controls everything? It can – if it is "pushed" and "prompted" in time. I will comment it below, but for understanding and analysis there is one remark, which is important – there is no "energy flow" without a matter flow. Such is the logic of an active matter, which has two original properties: ***repulsion and attraction***.



Thus, here is an intermediate conclusion for understanding the "work" of the Programs – the fields matters are the primary creation of the developing matter and they interact with each other. The question of the interaction of fields is, first of all, the interaction of field matters, static fields with each other and kinetic flows of field particles with electrons of bodies. That's why you can "push" the Brain so that it could "understand" – what it has to do. But the Brain's design is very complex. Any false step can push it into the past. And the past rarely touches the Mind. But sometimes it may be necessary so that not to do any harm in similar things – at least to go on an excursion into the past. So, let's go for the memories of what was known in the perspective of the unknown.

6.5. An excursion to the past

It is known that the center of the Earth is displaced to the South Pole, as a result of which the southern hemisphere is more covered with water than the northern one, and the contours of all the continents and most of the large peninsulas end up with tips to the south. Mars, for example, has a similar picture.

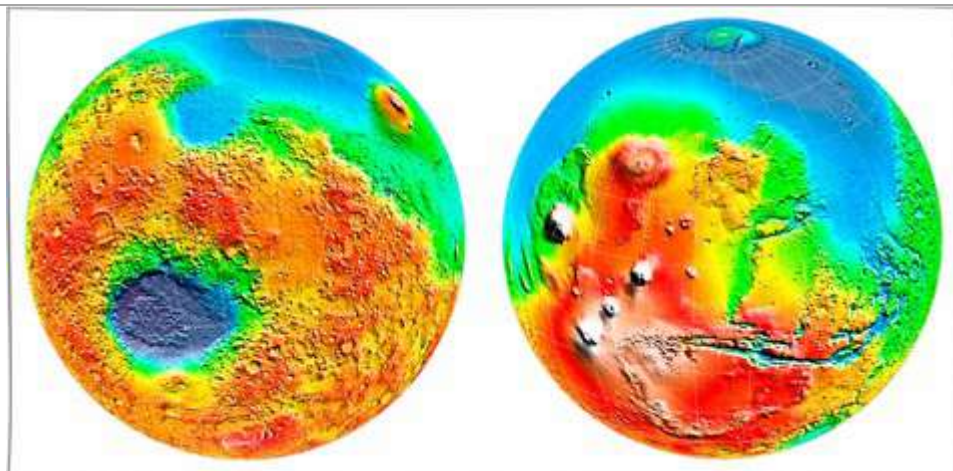

This make us look for some extraneous cosmic impact, causing both planets to have simultaneous ebbs of surface liquids either to that part of the Milky Way, which is now shielded by the Southern Cross, or to the one before which ***the Cassiopeia constellation is now shining***. But this alternating transfer of liquids would be explained by cosmic influence only if we assume that the present actual movement of the solar system towards the Hercules constellation is not straightforward, but is only the present direction of the orbital revolving of the Sun around some invisible, but photochemically active central body which is projected for us in the galactic part of the sky (these cannot be Magellan clouds, because according to Wilson's spectral studies, the solar system moves away from the Greater clouds at a speed of 277 km/s, i.e., 9 times faster than the Earth's actual orbital motion around the Sun, and the Sun moves away from the Small Cloud at a speed of about 158 km/s. This also indicates that the Small Cloud orbits the Greater one, that is, rather, both revolve around a common center of gravitation).

It is necessary:

a) that the center of the solar system revolution should be that far away from it so that the widths of the Earth and Mars appeared to be immeasurably small compared to its distance, otherwise the attraction to the back of these bodies would differ from the attraction to the front, and therefore they would have, except lunar and solar, some, special ebbs and flows;

b) or that should be two mutually compensated centers, like the tree structure – roots, trunk, crown, where, as will be shown later, structural changes occur that affect the Earth.

At perihelion, the Earth is 145.700.000 km away from the Sun, about 151.800.000 km at aphelion. Since solar radiation weakens in proportion to

the square of the distance, taking the difference between the aphelion square and the perihelion square and dividing it by the aphelion square, we get 0.079, i.e., about 1/13. Such a significant value cannot be ignored (temperature difference – 23°).

I'd like to note that:

a) the Earth's orbit perihelion fell on the day of the winter solstice in the northern hemisphere of the Earth and in the summer – in the southern one (i.e. northern summer and spring were 8 days longer than northern autumn and winter, and southern winter and autumn were 8 days shorter than southern spring and summer) in:

-76.200 ;

-50.400;

-24.600;

+1.200;

And will be in:

+27.000;

+52.800.

Repeat every 25.800 years.

b) the perihelion of the Earth's orbit falls, on the contrary, on the day of the summer solstice in the northern hemisphere of the Earth and in the winter – in the southern (i.e. the northern winter was 8 days longer than the southern one, and the northern summer 8 days shorter than the southern one) in:

-63.300;

-37.500;

-11.700;

and will be in:

+14.100;

+39.900.

Our Earthly "cradle" is always in perpetual swing and this in one way or another has influenced Human and all living Life Support System on the Earth, as an integral and necessary part of life support.

Let's consider the age-old effect on the structural changes of the periodic change in the ecliptic slope towards the Earth's equator between **21°58'5"** and **24°58'5"** with amplitude of **2°77'5"**.

Currently, we are at a half way to this amplitude and go to its minimum at a speed of 0°0,128' in a hundred years, but this speed reduces when reaching extreme positions, like a pendulum. ***The calculated parameter on the ecliptic exactly coincides with the spin parameter of the hydrogen atom*** for the central position, that is, at the present time we have a resonance, **THE PEAK OF WHICH FELL ON 1955–2012**. The total period of the change in the ecliptic inclination to the earth's axis is 62,000 years, with passing twice through the resonant contour. ***The events that took place on the Earth 31.000 years ago are a mirror reflection of the events that have been taking place since 1995*** (that time there was an inverse sequence of events – of structural changes). Currently, there is a flow of emission (the power of which increases daily), which is not characteristic for the Earth "perception". This flow, resonating the "black hole" and the "white spot" – positive and negative masses – brings to changes in the spin parameters of the latter and makes them visible in the optical spectrum. Since **THERE IS NO EQUIPMENT**, which allows measuring the emissions characteristics at longitudinal waves, we note that in the optical range we see ***yellow flashes***, which are characteristic of the spectrum of the nitrogen series emissions (up to gold).

The "white spot" forms flows which are seen on the Earth as "circles on crops" of various forms.



At the extreme points of the ecliptic slope, the Earth appeared **every 15,500 years**. It was the time of the thickest blanket of snow and summer thawing at both poles of the Earth, that is, a period of great floods.

So, summarizing what is happening today – **every 31,000 years**, the following transformations take place on the Earth:

- shape, frequency, power of the impulses emanating from the Hartman zones (Curie) change;
- lithium content increases in the elements compounds;
- time reduces;
- acceleration of free fall changes and, as a result, the force of gravity changes;
- taking into account the presence of three physics
- (physics of uncompensated emission, equilibrium physics, physics of uncompensated absorption), the particle spins shift by the angle corresponding to the **CENTRAL POSITION OF HYDROGEN ATOM**, as a result of which the masses of matter with spin parameters that are not available for perception in the conventional range will be observed in the optical range, for example, three suns that so recently "aroused" astronomical science and the entire scientific community;



- there takes place transmutation of elements (an atom seems to "swell"), while maintaining the atomic weight, one atom is replaced by the group that includes lithium.

More than 18,000 years ago, the civilization disappeared, **WHICH TRACES WERE DISCOVERED** in the town of Chekhov, Moscow Region. (Two pyramids turned at 45°, dozens of small pyramids). The depth of the pyramids is 8 meters.

"Wonders" occur in this region – at a certain time, a luminescence is observed in the optical range, optical lenses are detected (from the plane), **a placer of black zircons is found** (rather rare for the Earth), etc. The

mathematical calculations of the above processes are given separately by A.Khatybov in the monograph "***Cold nuclear synthesis***".

Infra red (near) with a range of **6500–100000 Å** emanate from the Earth in the Hartmann grid (Hartmann (Curie) zone).

The center is the Earth magnetic center. The nature of the grid is shown in the figure.

The emission occurs in the grid nodes – on longitudinal waves (Dokuchaev V.I.⁷¹), the frequency changes in the direction of increasing the wavelength from the center to the periphery by 36%. On the surface of the Earth (sea level) the grid size is 1.7×1.7 meters. The emission frequency is about 4.2 MHz, which corresponds to a third yellow lobe.

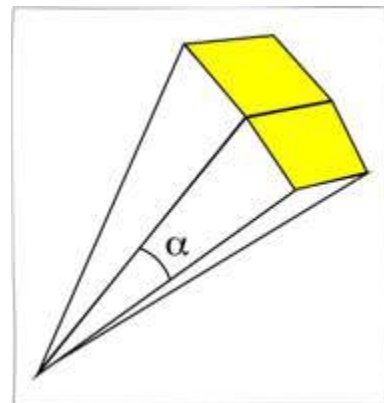

With a spectrum of 6707,76 Å, the brightness (B) is 3600, which is not observed with any atom.

With imposition (curvature) of the direction the luminescence in the optical range (a fifth lobe) is observed.

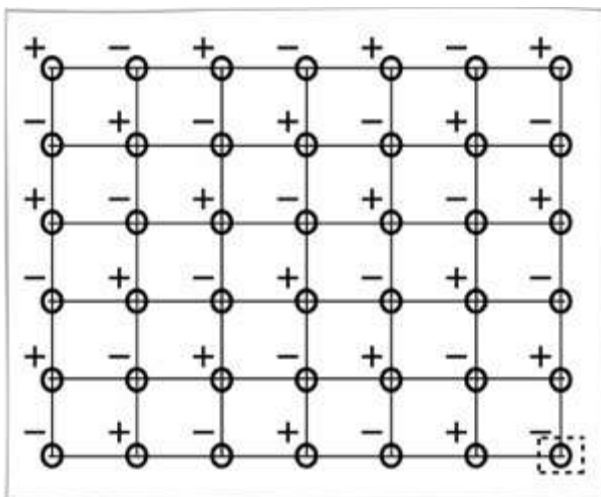

The physical basis of the emission flow is the conversion of the first yellow lobe emission (about 1.2 MHz wavelength) – the resonant circuit of the hydrogen atom.

Of the four points of the Hartman grid, 2 points are absorption (minus), and 2 points are emission (plus).

Emission and absorption occur at different frequencies. Absorption is related to hydrogen (there is about 5% on the Earth).

⁷¹ Vasily Vasilyevich Dokuchaev (March 1, 1846 – November 8, 1903) – Russian geologist and soil scientist, professor of mineralogy and crystallography at St. Petersburg University (1884–1897), director of the Novo-Alexandria Institute of Agriculture and Forestry (1892–1895). Known as the founder of the school of soil science and soil geography. He created the doctrine of the soil as an independent natural body, discovered the basic laws of the genesis and distribution of the soil (natural zonality).

Cosmic emission (absorption for the grid) is related to a hydrogen atom with a. e. m. = 1.0079. Hydrogen isotopes do not have a similar resonant circuit. Based on the fact that the Earth **is 95% silicon (Si)**, the emission from the center of the Earth is related to resonant Lithium (Li) grid: **Si=Li₂O**. Li isotopes with resonant circuits: **Li₅, Li₆, Li₇, Li₈**.. The remaining isotopes have no resonant circuits. With the basis – lithium, any compound can be expressed through lithium, for example: **HCl↔LiF, or Ni↔MnLi↔TiLi₂↔KLi₃↔SLi₄↔ALi₅↔NeLi₆↔NLi₇↔BeLi₈↔HLi₉**

In man's organism there is **less than 0,0001 %** of lithium and its isotopes. When it enters the Hartman zone, **the resonant circuits of lithium and its isotopes are activated**, the elements are transmuted, the frequency range is rebuilt. Based on the research conducted by A. Khatybov, it was concluded that **ALL VIRUSES CONTAIN RESONANT LITHIUM CIRCUITS**. **Since the hydrogen symmetry system is disrupted, which is the skeleton of the cellular systems of the body, the disintegration of the system is observed. And the only way to transfer the body into a hydrogen symmetry system is to change the relation in favor of resonant hydrogen circuits.** Of 108 different structures of hydrogen, there are structures with resonant circuits necessary for the normal functioning of the body cells. Note that the emission from the Hartman node grid **occurs according to the scheme: cosmic emission on the first yellow lobe ⇒ invert, frequency change ⇒ radiation on the third yellow lobe.**

Calcium (Ca – a. E. M. = 20) – the basis of the bone skeleton is a structure in which, when conditions are created, the true atom is replaced by an "isoster": **Ca ⇒ LiCl (a. E. M = 20), i. e. destruction of bone composition takes place.**

Similarly, calcium (**Ca⁺⁺**), magnesium and other "pumps" are in cells, and there are 144, as it is known. Inverted flow (3-d yellow lobe, frequency about 4.2 MHz) of the non-optical range emanating from the Earth in Hartman zones. In terms of frequency, the emission does not coincide with the emission received by the Earth from Space.

The state of the biological system is characterized by the fact that with an increase in the vector rotation angle of atoms group (1), atoms transmutation occurs and there appear cells that do not provide connection with the ecosystem. In addition, the closure of the energy centers due to the

displacement of the vertebrae in the human body **AGGRAVATES THE PROCESS AND THE ORGANISM DIES.**

It should be borne in mind that different civilizations have different reactions to changes in the vector rotation angle.

6.6. White, Yellow, Black

The relation for the equilibrium state of particles distributed in space (vacuum) is derived from the new theory of symmetry.

Accepting the principle of "cake" – the layered structure of the material particles distribution in vacuum, we introduce the concept of **SPIN RELATION.**

For the reactions taking place on the Sun, we have:

1/4 – clockwise-rotation, 3/4 – counterclockwise-rotation.
Confirmation – **Alan de Crees** "Clash of rotary protons."⁷²

The existence of other relations is proved in the new theory of symmetry.

So, for the closed reactions, we must have the following relations:

3/4 – counterclockwise-rotation,

1/4 – clockwise-rotation,

2/2 – counterclockwise-rotation and 2/2 clockwise-rotation.

In vacuum, we have an approximately uniform distribution, but if there is a predominance of one group, it forms a separate mass.

Let 3 masses be formed (by spin parameters and, as a result, by reactions):

«Black star» ***Li*⇒*He*** (2/2, 2/2).

⁷² Professor Alan Krish – University of Michigan. In the circles of high-energy spin physics specialists, this name is widely known. Professor Alan Krish obtained unique experimental results in the study of polarized proton-proton collisions, which to date have no theoretical explanation in the framework of QCD (quantum chromodynamics, a theory describing the interaction of quarks and gluons).

«Yellow star» (the Sun) $He \Rightarrow H$ (1/4, 3/4).

«White Star» $H \Rightarrow Li$ (3/4, 1/4).

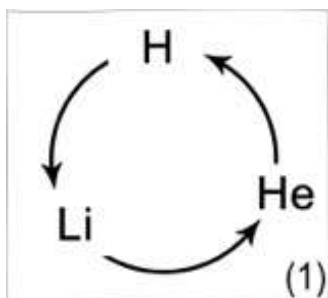

Transients conventionally are shown in Figure 1. The eternal rotation ensures the existence of planets and life on the planet. **Life on a planet is possible only with the existence of such a cycle**, that is, the presence of additional "generators".

Thus, for the universe, the possibility of life on the planets is significantly reduced, even if there are temperature conditions. Regarding the existence of separate masses with other spin parameters, one cannot disregard the magnetic relations.

We add that the reaction $He \Rightarrow H$ is continuous,

$Li \Rightarrow He$ – impulse, frequency – **8 hours**,

$H \Rightarrow Li$ – impulse, frequency – **8 hours**.

The ozone layer change is the reaction to the change in $H \Rightarrow Li$ reaction.

The classical idea for the **H-E** relations has penetrated so deep into the consciousness that any other relation is simply discarded.

Looking ahead, we note that in addition to the classical relation, when the **H-E** diagram, shown in Figure 2, has an angle of **90°**, there are other diagrams, in particular, the **H-E** diagram with an angle of **64,4°** (Figure 3) and the **H-E** diagram with an angle of **39,2°** (Figure 4). We do not take into account the gravitational component in the diagrams, but this does not belittle the qualitative picture.

(Figure 3) и диаграмма **H-E** with the angle of **39,2°** (figure 4).

From symmetry:

- diagram H-E = 90° – in reactions $He \Rightarrow H$ (Yellow star);
- diagram H-E = 64,4° – in reactions $Li \Rightarrow He$ (Black star);
- diagram H-E = 39,2° – in reactions $H \Rightarrow Li$ (White star).

The magnetic field of living cells corresponds to the diagram **H-E = 39,2°**, when measuring the magnetic field it is necessary to make an amendment.

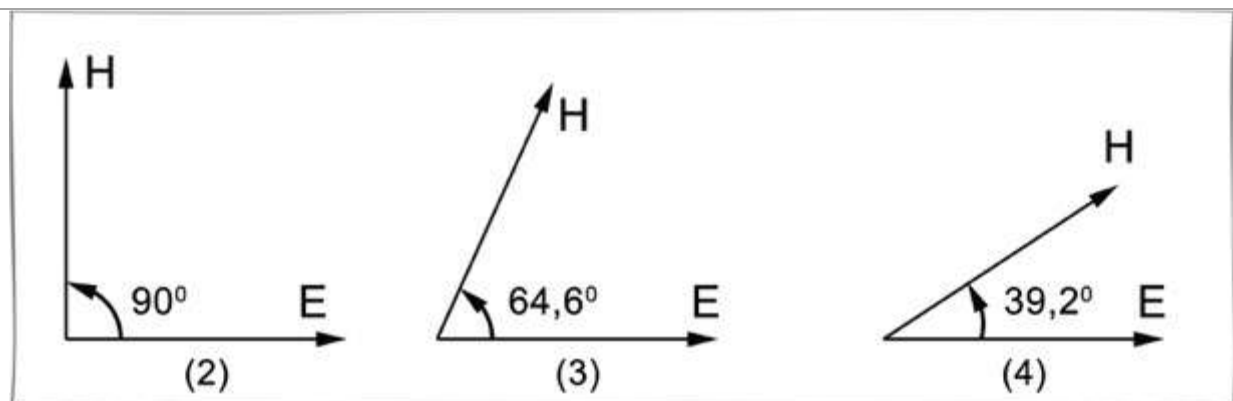

Asymmetric magnetic field of a living cell forms a biological clock. A complete turn of the field vector corresponds to the biological cycle.

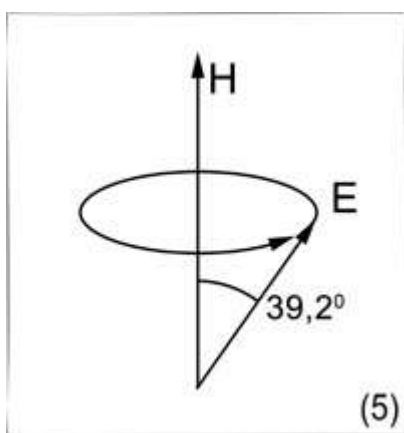

Figure 5 conventionally shows the **rotating vector of a biological clock**. Acceleration or deceleration of the cycle depends on the rate of reactions between the three masses (Figure 1).

Every living cell has electric and magnetic centers. In the process of life, these centers move (precess).

Each of **the 144 types of human cells** creates its own magnetic and electric fields of various frequencies and powers.

The coincidence of individual fields in frequency **ENHANCES THE RELATIONSHIP OF A BIOOBJECT WITH THE ENVIRONMENT**. Excessive concentration of fields and a reduction in their number, at certain moments lose their connection with the Cosmos and result in the death of a bioobject. The role of **the "SvetL" Programs** is already clear to everyone.

Previously, some conclusions were made regarding the field characteristics of the civilizations types. At the moment of the active change in the quality of **$H \Rightarrow Li$** reactions, a bio-object **DOES NOT HAVE TIME TO REBUILD THE FIELD SYSTEM**, and those bioobjects who at the time of active reactions loose their connection, pass away. This process is picking up speed lately.

Taking into account that at the time of active reactions the optical spectrum is expanding, the sensitivity of a bio-object is growing (with the number of fields > 6), it is expected the opening of additional centers of sensitivity. Under the conditions of altered reactions, it is necessary to have

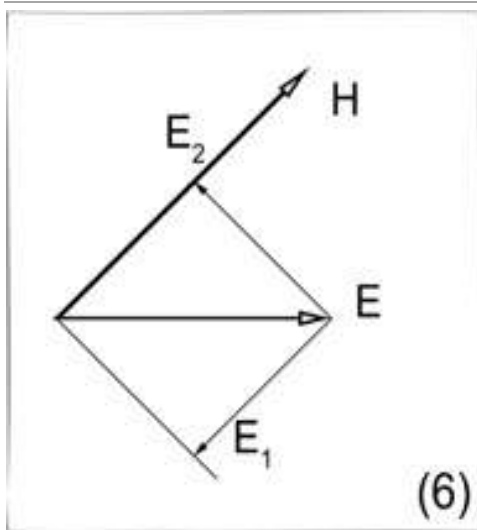

"equipment" for fixation of the combined electric and magnetic fields (Figure 6), since no amendments will give any result of a qualitative change in these or those parameters of a bioobject. Today, this equipment is **the "SvetL" Complex with its Programs**; however, I set the task to solve this within the framework of **the DI Complex** potentialities in its work on the area and in the framework of "protecting people" located in this area.

Under the conditions of existence of various **E-H** systems, it is necessary to revise the classical idea of the magnetodynamics equations.

Thus, three types of reactions bring to the existence of three masses, which really exist in the Solar System. We called them "White", "Yellow" and "Black" Suns (figure 7).

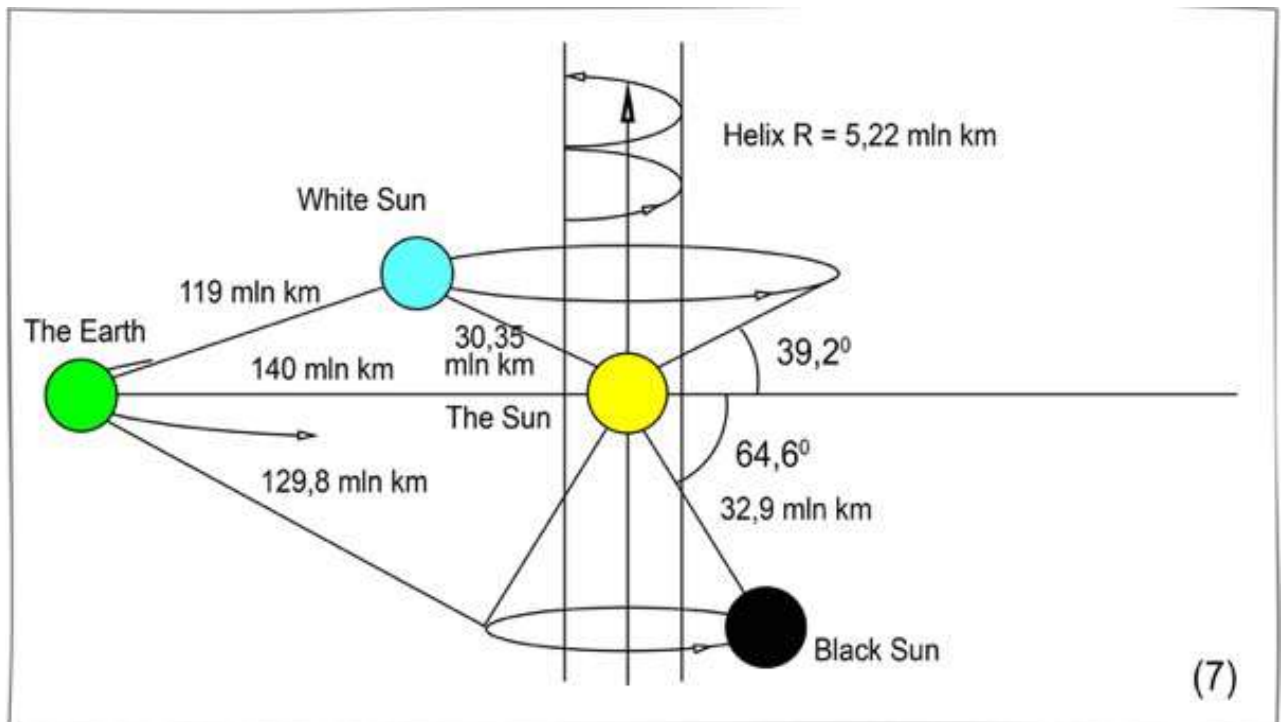

If we regard the Earth movement as counterclockwise, then "White" Sun is above the Ecliptic, "Black" Sun is under the Ecliptic, but we constantly "associate" with "Yellow" Sun. Approximate distances and angles are shown in the figure.

Note that all three masses form a dumb-bell, the rotation of which is accompanied by the movement of the entire system along the right helix (the helix radius is approximately **5.22 million km**).

Relations for masses:

M White star $\approx 0,02$ MSun.

M Black star $\approx 0,004$ MSun.

The orbital period (around the Sun) of the "White" and "Black" stars is approximately the same and is about 11 years, with a complete rotation of the entire Solar system.

The Sun magnetic activity coincides with the orbital period of "White" and "Black" stars.

In the period **from July 1995 to March 1996**, "White" Sun was closer to the Earth. At the same time, the presence of the oscillations period of 31.000 years (**we are now in a 5-year resonance – the entire system passes through "o" point**) **BRINGS TO IRREVERSIBLE CATAclysms** taking place on the Earth. Taking into account the optical range change, "White" and "Black" Suns will be visible, but when they reach temperatures above **700° K**. The table shows the temperature change of two masses, as well as the percentage of the Earth's ozone layer. As already mentioned, the state of the ozone layer depends on the reactions occurring on "White" star – in fact, exactly what N. Levashov wrote and said about the ozone layer of the Earth.

N	Date	White star temperature °K	Black star temperature °K	% of the Earth ozone layer
1	1.06.95	9	6	95
2	31.12.1995	40	60	92
3	1.06.1996	300	700	86
4	31.12.1996	750	950	75
5	1.06.1997	1300	2000	69
6	31.12.1997	2500	3700	64
7	1.06.1998	3200	4200	57
8	31.12.1998	4400	5000	52
9	1.06.1999	5500	3800	48
10	31.06.1999	7000	1800	58
11	1.06.2000	9400	200	82

It should be borne in mind that the emission power of "White" star is constantly increasing, the electromagnetic cells components of biological objects are changing, and so far the only way to stabilize the process is to

restructure hydrogen to create the prerequisites for **He \Rightarrow H** reactions. How to do this, I think, is already clear.

A NEW PROTON STAR IS FORMED, the Sun is going out and the Earth is turning to a new gravitational field. All these processes are objective and occur as part of the transformation of the Life Support System and return of its potentialities to the state in which it had been before the seizure of the Earth..

6.7. "O" Civilization

It has been determined that there are representatives of 8 civilizations on the Earth, in percentage of the total population are:

- 0 civilization – 88.0%; number of fields = 4;**
- 1 civilization – 0.25%; number of fields = 7;**
- 2 civilization – 0.56%; number of fields = 24;**
- 3 civilization – 0.85%; number of fields = 36;**
- 4 civilization – 9.2%; number of fields = 64;**
- 5 civilization – 0.11%; number of fields = 72;**
- 6 civilization – 0.87%; number of fields = 84;**
- 7 civilization – 0.16%; number of fields = 118.**

The types of civilizations are precisely determined from the genetic tables, regarding the actual settlement. To this can be attributed the wave spectra influence of the lying deposits (both already formed and new ones). Let me remind you an example.

Georgians belong to the white race, but the place of settlement is in the zone of the manganese deposit. And basically, this is the district of Chiatura town. The entire population residing in the territory of Georgia has developed a genetic code (additional), including new "nuclear reactors" with manganese in the second group of atoms. This group is of blood and liver. Since at present the field has been exhausted and the spectral characteristics of the area **DO NOT CONFORM TO THE GENETIC CODE**, all Georgians living in this area **suffer of the blood "thickening" which results in the thrombosis**. And it is massive, medical workers hide it, because they do not find any explanation to this phenomenon.

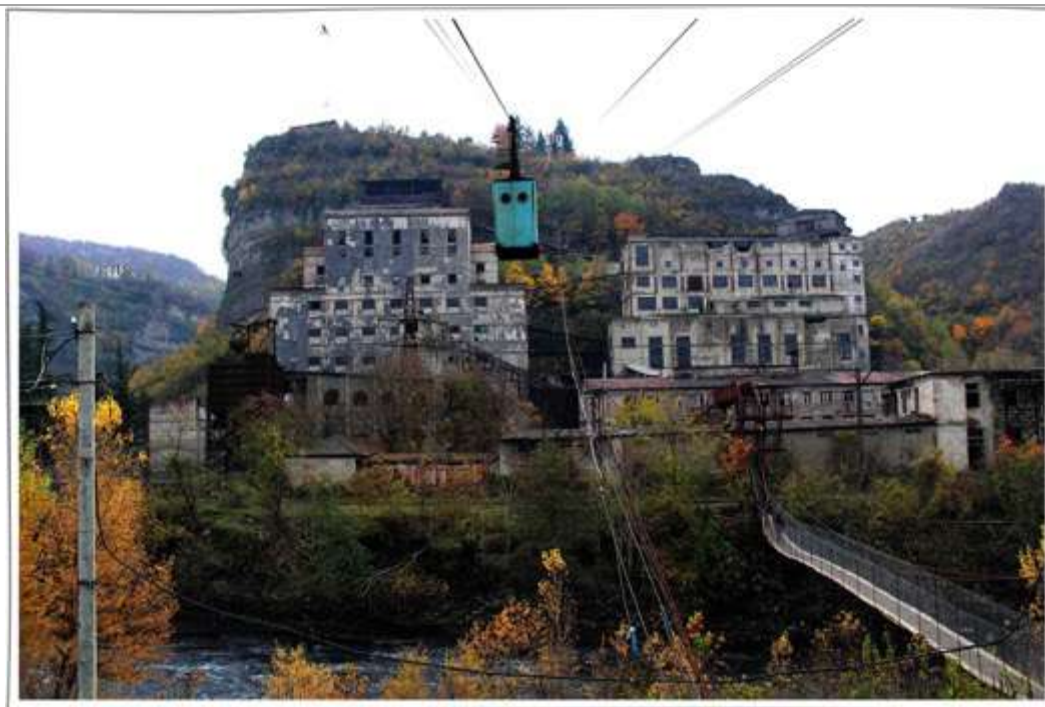

Chiatura – a vanishing town

Regarding the lack of "spiritual" fields, "O" civilization has inverted the event series, has turned upside down the sequence of historical events, has introduced so many apocrypha and myths over the millennium that it will take more than a decade to restore the truth.

According to the fields classification adopted in the work, "O" civilization has the fields: **0, 1, 2, 3**. Taking into account the change of metabolic field processes, the shift of metabolic processes towards the increasing number of the field, "O" civilization does not have the ability to adapt to changes occurring on the Earth now. Hence, the rapid process of changing the vector rotation angle of atoms group (1) towards its increasing, and dying off. The posterity of "O" civilization (marriage with any other civilization) will also be "O" civilization, that is, "O" civilization dies off completely.

With the largest deviation angle of the magnetic field vector in the structures of "nuclear reactors", this civilization dies off first.

Table of changes in the civilizations relations on the Earth.

The numbers of civilizations and their percentage relative to the remaining population.

Date (end of the period)	The remaining population%	0	1	2	3	4	5	6	7	Notes (vanishing of race or civilization)

1995	100									
2007-11	99,45									
2007-11	77,4									
2007-12	64,4									
2007-12	36,0									«0»
2008-04	2,25	-	1,6	3,4	6	60,2	1,2	4	23,6	
2008-05	0,9	-	0,5	0,3	0,6	27,2	0,4	6	65	Yellow
2008-06	0,124	-	0,03	0,02	0,6	14,5	0,06	2	83,4	Red
2008-11	0,084	-	-	-	-	0,12	0,04	2,24	97,6	Black, 1, 2, 3
2008-12	0,016	-	-	-	-	-	-	0,4	99,6	4, 5

Since **2010**, the population has been increasing. Civilizations will appear again according to the given schemes.

And I'd like to note – just for reflections, – ***the proportion of men in each case is 36% for each civilization***. Probably no need to explain why it is so today.

* * *

In fact, the whole world, built of photons and magnetic particles with its bitter and sweet, blue, yellow, red, alive and dead – is profound information to the genius design of our world, which the invaders were not able to destroy; having rebuilt everything "for themselves", having changed its laws of development in the infinite space, infinite matter and infinite "time". What an enormous and beautiful workshop to create new, simple and reliable, when quantity goes into quality, especially today, in the new opened possibilities of the transitional period that manifests itself before our eyes. I have seen for myself when "by the will of fate" I began to learn all that N. Levashov, A. Khatybov, N. Morozov, A. Luchin, and others who were invested with the task to carry new knowledge and new understanding. But people, by virtue of their innate selfishness, misunderstanding or unwillingness to understand what is happening, go on infiltrating new opening horizons, new science with its remarkable dialectical method of research – with the mathematical scholastics – the fruits of their weak human mind, – and try stubbornly and costly to do harm to the development of physics as an instrument of cognition of nature and society as a whole. This evil must be seen by people and exterminated by measures taken only through Cognition – the knowledge of Nature of the world around us and changing before our eyes. That is life. Evil is to be destroyed, but not by new evil and violence. The human experience is multifaceted. It gives a researcher a **TROUBLE-FREE TOOL – COMMON SENSE**, which makes it possible to separate the seeds of truth from the weeds of fiction, and to subject these seeds of truth to the final test of experiments, which I have been doing with

the "SvetL" Technologies. This way, the germs of the new science appear, which, being enriched by the experience of people, turn into a rigorous and credible science about Nature and the world around us. And this science finds their primary matter, understands the properties of these categories and sees such possibilities, which are feasible only for eternal matter, developing in the infinite space. Science has to be freed of ballast. The science that serves Man must be simple, understandable and necessary, but today it is very thoroughly littered, I would say, with the faeces of human ignorance. People do not understand the object of research, and already hurry to enclose it with a fence of their conjectures.

Dear so-called scientists and, mainly, businessmen from science, you'd rather measure areas, volumes, volts and amperes,.. the complicated ways of bodies under the action of group forces. If it becomes really bad, count stars in the sky, but you should not poke your nose into the matters created by Nature and solve eternal and infinite tasks for it with your mathematical philosophical and physical principle of the fictitious past. ***This is not only having no prospects, but also stupid.*** By rights science should take the leading positions in cognition and comprehension of the processes and improving the world and the people living in it. ***Only this way and not otherwise!***

Chapter 7. To hear and to listen to

What is music? It takes the place between the thought and phenomenon; as a predawn mediator, it stands between spirit and matter; Akin to both, it is different from them: it is the spirit that needs measured time; it is matter, but the matter that don't need space.

Heinrich Heine

The entire development of our world, and especially these days, at the beginning of the XXI century, looks like an intricate interweaving of various opposing principles and contradictory trends against the background of continuous action of random reasons, destroying stable, as we used to believe, structures and creating prerequisites for the emergence of new ones. In dialectics, as we were taught at school, the accepted terms "struggle" and "contradictions" reflect the tendencies noted above. I try to avoid them, because, in my opinion, they are to some extent related to the concept of goal-setting, which makes sense only for a living matter. Self-organization, as a natural phenomenon, knows neither struggle nor contradictions – ***what happens is the interaction of contradictory tendencies***, which ultimately come to harmony with each other, removing the conflict between them! For example, in winter, between the mass of cold air above the lake surface with warm water there is a conflict (the air cools the water, and the water in the lake "heats" its upper surface with the warmth coming from inside), which is settled by the fact that at the place of the air and water contact the air and water have the same temperature i. e. the conflict is removed by the ice. In this the dialectic of nature manifests itself, its language. All the concepts are brought in by the researcher, in the form of his own (intelligible to him) understanding, when trying to describe reality, – a subjective interpretation is formed: ***dialectics is just the language adapted to describe mental activity***, on the one hand, and the language in which the objects of nature communicate among themselves, on the other hand. When interpreting what is happening in nature, one can do without it – if there are several logical and consistent explanations of a phenomenon, the simplest one should be considered correct. I always try to lay down the principle known in science as the so-called "empirical

generalization" as the basis of my reasoning. Its meaning is that as the starting point of any analysis of everything that happens in inert matter, living matter or society, there should be statements that are consistent (non-contradictory) with empirical data, i. e., our experience – the experience acquired by us in practice. Adherence to this principle, and I have repeatedly been convinced of this, makes it possible to increase the **likelihood of realization of the intended development of events**, but, of course, it does not guarantee that the conclusions made on the basis of empirical generalizations will have absolute certainty. Empirical generalization⁷³ is just an interpretation, too.

Basically, the principle I use is based on some deeper statements that are of a primary nature – they can no longer be proved, they cannot be reduced to simpler ones, they cannot even be defined – they have to be either accepted or rejected. Today it concerns the knowledge that, for example, can be gained from the works of N. Levashov, A. Khatybov and some others who carry new knowledge. Such an approach made it possible to solve the tasks that I set for myself, including those related to **the "SvetL" Programs**. The basics of such statements are the following: **the world, the surrounding Nature are accepted as really existing**. This statement is the primary one: it is not explained, as well as the meaning of the word "existing". The formulated statement is either rejected or (as I see it) accepted without proof or comments. In this I see the main difference from those who admit that the material world and all things around us (not to be confused with the consumer's understanding of this concept) exist only in our imagination. It is from these positions that we move further in our knowledge of realities.

7.1. The necessity to think

Doubting everything, believing everything – these are two solutions that are equally convenient: both of them save us from the necessity to think. And if man is not able to think, even if he has read an enormous heap of

⁷³ So, an empirical generalization is always some interpretation of reality, and it is not unambiguous: different empirical generalizations can correspond to the same set of empirical data. The same colors can be used to paint the same landscape in very different ways. And no final experience can eliminate the ambiguity of interpretations. The development of intellect and new knowledge also cannot become a guarantee of unambiguity, for new knowledge reveals new layers of problems that exclude the possibility of a closed system of axioms! Man always makes decisions under conditions of risk and uncertainty which cannot be removed.

books, then he deserves ***only to be called a bookcase***. In order to improve the

Mind, we must think more than learn by heart. If that which sails is a boat, but that which makes it possible to sail is water, and not a boat; that which moves is a cart, but that which makes it possible to move is an ox, not a cart, then thinking is the Mind. Therefore, the peculiarity of the living Mind is that it only needs to see and hear a little so that it could ponder it over for a long time and understand a lot.

The world is continuous, and our senses are discrete. Claiming this, we a priori break up the world in which we live – separating some part of it from the whole.



Picasso «A nude in a red armchair»

cubism, he got interested in it, he is ready to accept its possibility, rationality and even the prospects of this trend... But if you show it right away without preparation, it's obvious some bewilderment, at least

Removing from the world the sounds in which we exist and trying to somehow study them, see them separately – we do about the same thing. All our life is permeated with sounds, "created" by nature itself and by music. They exist in the form in which they exist, and were, as if, (from our human point of reasoning) separately attached to all that exists. The sound arises because of the vibrating motion of particles and objects: the smallest – such as atoms, and the giant – such as planets. We, people, are also a product of nature (but here, of course, the concept of "nature" should be clarified), and there are many who already realize that the world consists of an infinite

number of frequencies, and every creature, including man, occupies a certain frequency niche. Every biostructure on the Earth has a certain set of frequencies, and all of them are gathered together in Man.

Man, as a unique creation, was made precisely on the Earth, having with all that the entire set of octaves from 16 to 128⁷⁴. We have abilities and the need to know everything that exists, including ourselves, but there is a habit of breaking the whole, pulling out of it, for example, sounds as something separate, fix them and somehow formalize, label, decompose into octaves, tones and so on – **THIS IS NOT QUITE COGNITION**. **This is a description** that is required for discussion, exchange of views. We create a system of concepts that we denote in words, **but this will not give us knowledge about the core of the phenomenon**. With the help of these concepts, we, modern people, can accumulate and convey to people the same amount of information, for example, on this phenomenon, which we call sounds. Cognition implies, in my opinion, understanding of the point. However, it makes no sense to dismiss the senses and the information obtained through them, but all the same I would like to try to look deeper and see a more or less whole picture, and not tonalities, registers and timbres.

Turning to the system of concepts built by humanity regarding sounds, we begin to suspect that sound and color are in some way relatives – the color perception of music is an infrequent phenomenon, but known.

The composer, philosopher and brilliant musician, **Alexander Scriabin**, in his Symphonic poem "**Prometheus**" created **the concept – LIGHT-COLOR-SOUND**: he visualized the melody with the help of color and always dreamed of his music being not only heard, but also seen. He was a synesthetic⁷⁵ – a man who had a "color" ear – he saw various colors in his

⁷⁴ **Let me remind the readers** that all biostructures, including humans, are constructed in such a way that they have the entire set of octaves from 16 to 128. They are different in purpose and the predominance of one or another group of octaves forms the basis of the biostructure. Functional separation by octaves: – 16÷32 – all types of gases and water (breathing and water are necessary for all); – 34÷46 – reincarnation (all structures tend to accumulate the frequency potentials of these octaves); – 48 – distributor; – 50÷52 – energy balance; – 56÷62 – the organs control; – 64 – material structures; – 66÷72 – The brain; – 74÷86 – reincarnation control; – 96÷126 – control; – 128 – the defining clock generator. All kinds of plants, herbs are frequencies of octaves 34÷44. The dispersion of high octaves occurs rather slowly, and if man died with bone frequency potentials above 122%, then even after 1000 years, these bones can be applied to sore spots (relics of Tamerlane, etc.).

⁷⁵ **Synesthesia** (from Greek – a simultaneous sensation of a joint feeling) – in psychology is the phenomenon of perception, when during stimulation of one sensory organ (as a result of irradiation of arousal from the nervous structures of one sensory system to another), sensations corresponding to another sensory also appear.



mind, whole visual images while listening to music or individual sounds. Scriabin was a genius, but there were many who considered him a "weird genius."

It is now believed that synesthesia is not a mental disorder. In one form or another, the sensation of the connection of individual notes with color or other sensory sensations (smell, tactile sensations, warmth and cold) is inherent in almost all owners of absolute pitch. Focusing on the development of Scriabin's ideas of the "light symphony", combining efforts with art theorists, musicians and artists, light music in the field of sound synthesis and synesthesia ("color hearing") appeals to both sight and

hearing. This is a kind of "dance" of light-colored ornamental projections, constantly changing in shape, brightness and color. A man had the possibility to "see" music before – through the perception of dance, ballet: it was not for nothing that the dance since antiquity was called "music for the eyes". Light music is like an instrumental "continuation" of dance, expressive and intonation art.

Extrasensory, that is, perception beyond the usual sense organs, also shares these two directions (sound and color) – someone can "hear", someone can "see" (and someone can both) beyond the audible and visible. So the question is obvious – are sound and color two discrete, fundamentally different properties of each atom, molecule, compound, etc., or is it a manifestation of something the same, and the observed discreteness is generated by the limited perception? In fact, if you think a little and remember what you have read, the answer is obvious. In many popular science books (and in my, I hope, too) there are many questions and "problems" to which there is no answer. Because the book can not be the size of a book case. But most questions have no answer. Today's science still does not know the answer to them. And this awakens curiosity, unfortunately, not in everyone, but still in quite a number of people. They begin to examine these issues, fields of knowledge, "dig into" with the help of **THEIR KNOWLEDGE AND EXPERIENCE, CREATING NEW KNOWLEDGE**. And this is extremely important and valuable.

If we approach it from the other side, man can get information not through his sense organs, but directly by the Brain (in other words, with the help of some "special" sense organs). Having at the present time and at this level of development in its active state only a part of the consciousness, all the information that comes directly through the Brain remains outside its limits – man is not aware of it because it does not come into contact with the existing active experience. The brain has nothing to compare with the information received and, although it was received by it, it cannot be processed and allowed to active consciousness – it cannot be cognized. In fact, it does not exist for humans.

Armed with these conclusions, let us turn to the fragment from the book "*The Mirror of My Soul*" by N. Levashov, when he and Svetlana "made their way" through the black abyss to where they had come from, and were faced with the fact that they could not find anything "similar" to themselves in the "composition" of the obstacle. To some extent, this is very similar to what the Brain faces when receiving information, but without being able to forward it to awareness through the "black abyss" in understanding – this information does not fit in with the world view and experience of man. Similarly to the one described by Levashov, it is still possible – by looking for something similar, even in something similar from the whole system of understanding created by a human being, one can gradually, slowly, and with great difficulty move forward. At first, a very tiny part will be understood, subjected to thinking over and over, but it will immediately begin to expand the boundaries of understanding, making it possible to make another step to cognizing.

7.2. To receive, to master and to talk...

So, the Brain, after receiving information, translates it into awareness through the man's conceptual basis. But it is now built on the basis of information received ***through the usual sense organs*** – hearing, sight, smell, etc. Therefore, we recognize the grains that we can perceive as a visible image (shape, color), smell, touch, taste and so on. The Brain translates what it received into what we understand – but **THAT IS SAID WRONG**, because **WE ARE OUR BRAIN** in the current shirt, whose abilities are limited. ***Our distorted world view and self-awareness limit our own abilities – the abilities of the Brain.*** I should add here – up to

now and regretfully. Man is one of the structures that has the Brain, and far from being optimal.

Of course, the Brain's genotype is important here, but from the experience gained in using *the "SvetL" Programs*, they quite cope with this in many cases, without destroying anything, but interacting with the natural being. As an example, blindness is perceived most acutely by man, and not the loss of hearing. Vision is the channel through which man receives most of the information. The channel of hearing is less loaded. That part of the experience that man gets through vision is more significant than others. For this reason, the so-called "visions" of people are more common than "voices from the above".

So, to put it more habitually, but still with some progress in understanding: The Brain receives information and "sends" it down into our consciousness through filters of the physiological organs of the body (our shirt). Therefore, we separate, for example, color and sound. Each sense organ perceives electromagnetic radiation in a certain unique frequency range. The sound is in hertz, the light is in terahertz. Telepathic perception of the Brain, respectively, is even more high-frequency. At the level of our perception today, to see the sound for man is the same nonsense as to hear color, but I hope that the reader having read the previous chapter already understands that **IT IS NOT SO, AND IT IS POSSIBLE**. However, a habitual suspicion prevails and a natural suspicion arises, consisting in the fact that much distorted information "reaches us" – distorted because it is cut off by understanding and imagination through limited variants of sensations (sound, color, smell, etc.). But there is one "but" – any human who is able to obtain this information with the Brain at least in some form, will confidently say that, for example, colors, "there" are different – not like those we are used to see "here". Seeing with the Brain *never coincides in detail* with seeing with the eyes, if only because, *firstly*, the Brain sees with a completely different frequency range and, *secondly*, because the optical signal transmission system is extremely imperfect, and the Brain is forced to automatically "draw in" details, complete the picture, not to mention the fact that it makes its transformation.

In the process of visual perception, distortions, mistakes, failures occur, but the Brain processes the received information and makes the necessary corrections. These processes are unconscious and are implemented in a multi-level autonomous correction of distortion. This eliminates spherical and chromatic aberrations, the effects of blind spots,

color correction is carried out, a stereoscopic image is formed, etc. In cases where the subconscious information processing is insufficient or excessive, optical illusions are formed. And in this connection, an obvious question arises – is it possible to operate with a different conceptual basis when analyzing information, and not putting it into the existing one? It is possible. In this case, the informative richness is immeasurably greater, and understanding is broader, but it becomes impossible to tell or, even more, verbally express it, because this way of conveying information from man to man is limited to the conceptual system that exists in present-day human society, which is based on "shirt" sense organs and a limited, but still distorted understanding. I touched upon this in detail in my previous books.

In an attempt to somehow distract from the above-mentioned discreteness, which we receive from the existing world of information, let us imagine a planet on which sentient beings, like people on our planet, have senses that are different from ours. They have no sight, touch, smell, or hearing, but there is, for example, something... let's call it the first words that come to mind, but which are incomprehensible to us – *ativnost*, *prevany* *confury* and *cruml*. The same world (in a broad sense) in which we exist, they perceive with the help of these senses, which we cannot imagine – because they allow these beings to receive information in a completely different range than ours, and we can not realize these feelings. Can we even find anything to talk about with them? What to talk about we do find, but how? This is another question. Actually, knowledge begins where we find what to talk about and how to "talk" to these creatures.

Our Brain, without failure of the functions that have been formed, acquired and supported, can only work with the mandatory energy-information guardianship from the objects of the Sun and the Earth at the same time! **BUT THIS IS SO FAR**, but later, with the higher level of the Brain octaves, this ability will be significantly expanded to several levels and complemented with the ability of "interplanetary integration" brought to a very high level of external "**musical accompaniment**".

But this is later, in a certain future, and not for everyone, unfortunately or fortunately is for you to decide. This very event, as a Cosmo physical process, is considered by the new science of the future, that is, ***the physics of the Brain and the Cosmic Anthropeology***.



So everyone striving to "look for contacts" with the representatives of "other civilizations" should especially take into account and consciously remember what was said at least at this primary information level! For real contact with representatives of other civilizations, first it is necessary to acquire some technical possibility and ability to "translate the neuron-connecting circuits of the Brain" (that is, forming communication tubes between representatives of civilizations), and then understanding each other is possible and realistic, as well as contact with them! Learn the "musical literacy of other civilizations" – but first you have to understand and figure out your own.

7.3. To turn on and off

If from this point of view we turn to such a phenomenon as sound, then it is obvious – **SOUNDS ARE THE GIGANTIC CHANNEL OF OBTAINING INFORMATION**, on the one hand, and on the other hand, *it is just one of the infinite number of other channels and possibilities*. The world around us is analogous, and all the observed phenomena around us have the same character. All devices inevitably obtain information about the world around them in analogous form. Sound is an analogous signal – a continuous flow of vibrations with varying amplitude and frequency, which can transfer infinite amount of information, since there is an infinite number of vibrations with varying amplitude and frequency. A digital signal are discrete (discontinuous) vibrations, the values of which depend on the transmission medium, and the transmission of a digital signal is carried out in an encrypted form. Digital information represents a series of discrete data,

and in its simplest form, a digital device has two possible states: *On. and off, one or zero.*

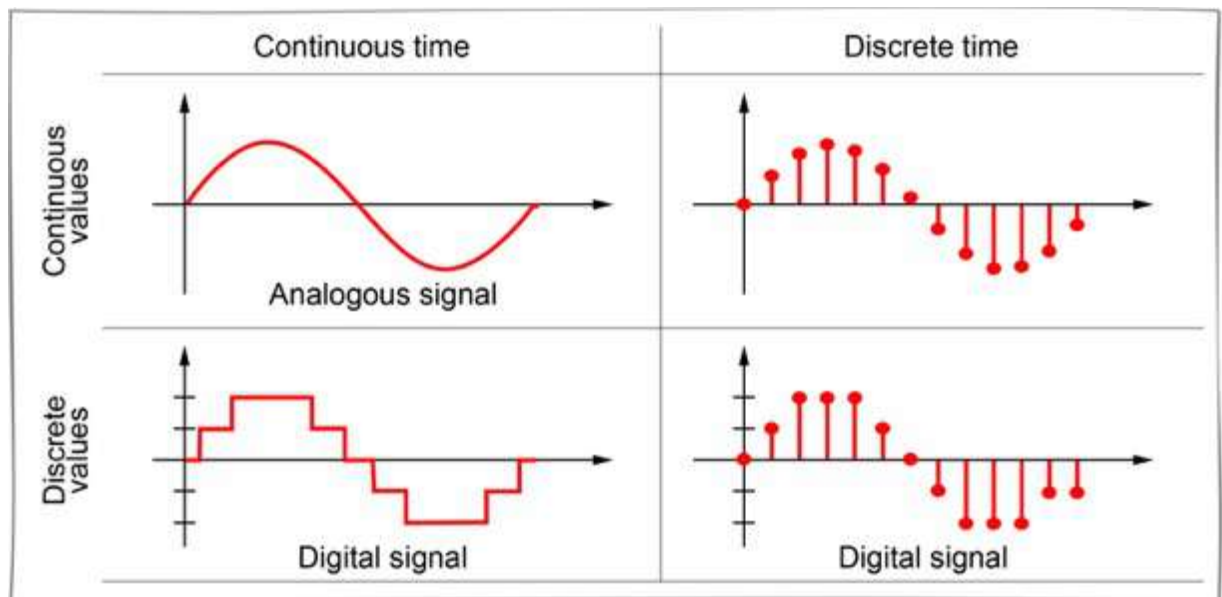

To understand the point of digital information, I will give you an example with sunlight. In digital information, the light of the sun can be represented – ***either it exists, or it does not.*** But in the real analogous world the light of the sun has infinite number of states – from dark, when there is no light, to super-bright. As you can see, the basic difference between an analogous and a digital signal lies in a different structure of the transmitted signal. Does not this remind you ***the analogy of the ridiculous splitting of the logical foundation of an extremely poor person into the concepts of "yes" and "no"?*** I think it would not be out of place to turn once again to the ***"Final Appeal to Mankind"***. In the case of analogous transmission of information, the entire spectrum of vibrations is used and transmitted. For music, this is important, and our ear is used to hearing the whole spectrum, i. e. all the information. We divide the word "sound" into two concepts: the first is a sound as a physical phenomenon; second, – a sound as sensation. When any elastic body vibrates, for example, strings, there occur pressure fluctuations in the surrounding air, which spread in space due to the elastic properties of air. These vibrations are called sound waves. They spread from the sound source in all directions (that is, each individual wave is a rapidly expanding sphere of high or low pressure). In gaseous, liquid media they are longitudinal waves, in solid one – longitudinal and transverse waves. Sound waves are captured by the auditory organ and cause irritation in it, which is transmitted along the nervous system to the brain, creating a sense of sound.

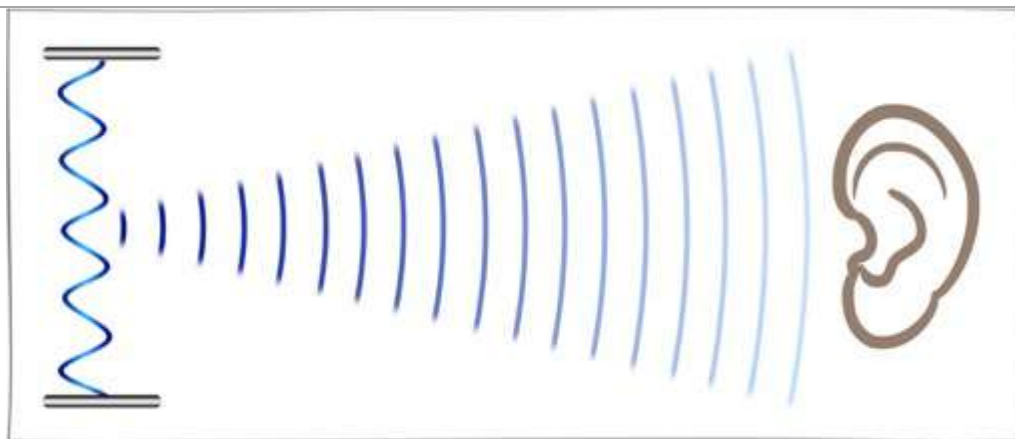

The sound of digital electro musical instruments due to the incompleteness (inferiority) of the transmitted information has, to put it mildly, an undesirable effect on the Brain. And even no super-decryption will help – it is impossible to decrypt the lost parts – those fragments that are cut off during the transmission. We have touched upon the constructive features of the information formation arranged on a digital basis for evaluating its destructive essence from the standpoint and methodology of the brain physics and the cell physics in the previous books. Let me remind you that the Brain, in fact, perceives information by orders of magnitude more than that transmitted by the past interventional System limited in its "energy-technical" possibilities and the senses of the individual created by it. The digital basis, forcibly imposed by the interventionist System, on the contrary, only complicated the work of a part of the Brain functions, bringing about the necessity of imposing a complex additional process of decrypting incoming information. In previous books, I have already dwelt on the fact that the most sophisticated way of destroying people is recently imposed digital technology. Look carefully around and you will see it for yourself. Even within such a gigantic channel for receiving information, like sound, we, alas, are severely limited now – our organ of hearing allows us to record sounds in a very short frequency range. These are vibrations with a frequency **from 20 to 20 000 Hz**. The wavelengths for these frequencies correspond to **17 m (for 20 Hz) and 17 mm (for 20 000 Hz)**. These wavelengths are given for air, the speed of sound spreading in which is **340 m/s**. There are still such ranges in which acoustics are involved – infrasonic and ultrasonic – these are mechanical waves, similar to sound ones. Infrasound are those that have a frequency **of less than 20 Hz**, they are not perceived by the human ear, their natural sources are storm, tsunami, earthquakes, hurricanes, volcanic eruptions, thunderstorms. Ultrasonic range is above **20 000 Hz**. The highest-frequency elastic waves in the range from 10⁹ to 10¹²–

10^{13} Hz are referred to as hypersound. Obviously, there is something beyond them.

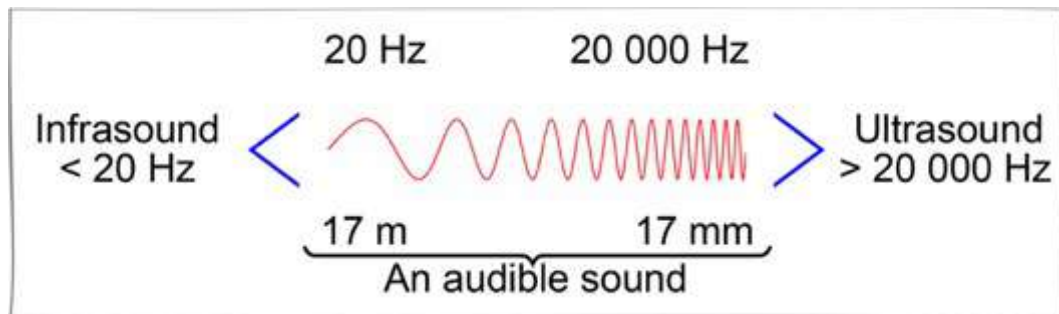

And what sounds do we hear in sleep and do we hear? We perceive the sleep as something whole – we do not separate sounds from visions. But, remembering the dream, we **FIRST RECREATE PICTURES**, not sounds – we describe actions, images, we can recall colors, their combinations, **but do not reproduce the audible sounds**. Another thing – we can remember the music (melody) from the dream – we can admire its beauty and harmony, but there are a few who can reproduce it. How much reproduction will correspond to what was heard? I think about as much as the picture seen matches the one drawn.

This is also true with regard to the images of generators that I made public – the correspondence is little, but even so, an obvious and sharp difference from all material (as an example, a picture of a fragment of the "work" of the Generator transferred from France to North-West Russia).

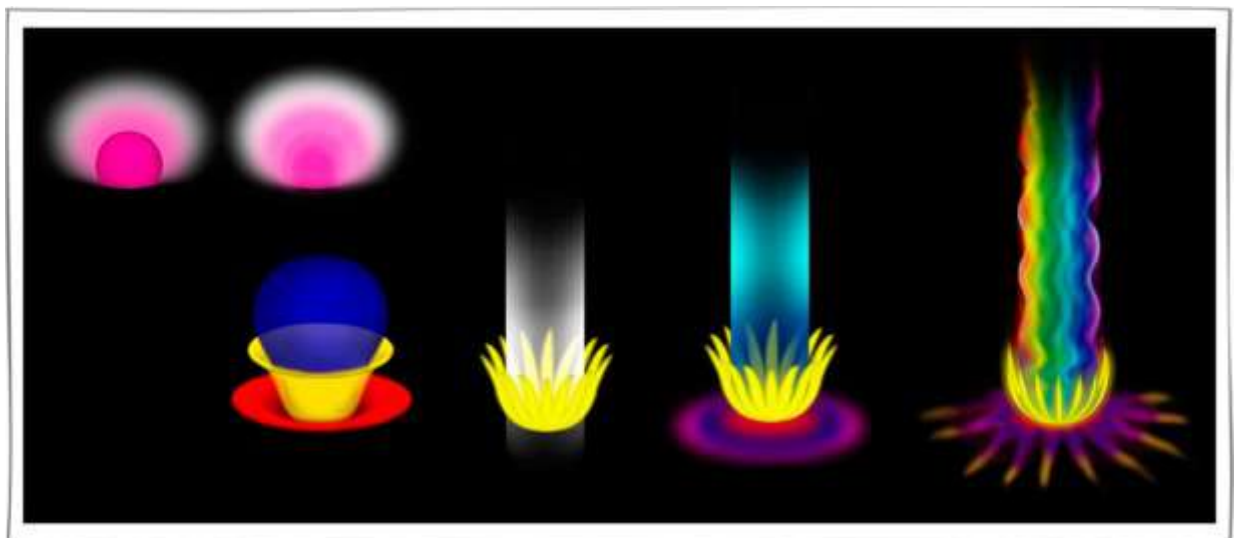

With respect to sounds, man has made a significant structuring, more significant than that of color. Sound (musical) structuring is made clearly – it is decomposed into octaves, tonalities; notes, tones, semitones, there is a division into dissonances and consonances, we know about minors and majors, in melodies there are stable steps and unstable ones, we have clearly

marked intervals, and all these concepts are laid out in a rather strict construction of musical literacy. Its laws and rules have been made, are known, followed, guided by them, but lately we have begun to learn something from which a strict, built up for more than one century construction **BEGINS BREAKING AND DISINTEGRATING** before our eyes. And more details about this see below.

What of the analogies of music literacy is in the arts? We have seven colors of the rainbow (like seven notes). And an infinite number of shades. We have a form as a category — and an infinite number of its variants. In general, we fall into a kind of stupor when we try to explain to ourselves the difference in the human perception of audible and visible. **Leonardo da Vinci** noted: "A painter has ten different arguments, through which he brings his work to perfection, namely: light, darkness, color, body, figure, place, distance, closeness, movement and peace". Now we are not able to easily (and even with difficulty) fully comprehend all these categories listed by the master regarding the depiction of visual images. Music can only be described as the sister of painting, since it is the object of hearing, the second feeling after sight. Music makes harmony by the combination of its proportional parts, created at the same time and forced to be born and die in one or more harmonic rhythms. What has man done by making "musical" structuring, in fact, being the same musical instrument? And is it possible to say that, by its structure, complexity, or simplicity, it corresponds to the "artistic" structuring? Is man able to draw something he does not know, has not seen? Is man able to create music that he has never heard?. Is man able after receiving some information, to present it both in musical and in sound form without losing part of the initial information? Aren't the color waves in the perception of the Brain, different than ours, sound waves? Can one hear the form or the music of an atom or the musical series of chemical elements?

It was with this that I was guided with and searched for the answers to the above questions (and not only) when I decided to create a health improving session based on the principle of Sessions created by N. Levashov, but using A. Khatybov's calculations and following his logic of building a musical series and many other things that I learned from his works.

We will go on with this, continuing the reflections begun in the previous chapter.

7.4. What I see with the same I hear with...

The ancient wise men did pay attention to the diverse world, richly adorned with all the colors of the rainbow, filled with aromas of flowers and plants, full of various living organisms. And that wonderful sky, on which you can look and see what you can see! Perhaps the first object in which man sought to discover the laws of being and harmony was the sky. It was the observation (vision) over the unchanging and eternal stars that first brought humanity to the thought that order and harmony exist in the world. And how do we see? For me, this was extremely important, because the idea of creating a health Improving Session to help people was to “bind” both the auditory perception of music and the visual image of what I planned to “tie” to the music. Not to create musical accompaniment of floating images, but to combine the image and music into a single whole.

The act of visual perception occurs in several stages. At the time of vision, light particles, known as photons, move, depending on the frequency of life support, from object to eye, pass through the lens of the eye, where they refract and focus on the retina lining the ocular fundus. Here, the rays of light are converted into electrical signals and transmitted by neurons, as scientists believe, into the “visual center” of the occipital part of the brain, or put it easier, – transmitted to the Brain. It is in the Brain that the perception of visual information takes place. We see with the Brain, and the eyes are the “tools” of the Brain, as well as the ears, nose and other parts of the body. All the images that we see in our lives, and all the events that we observe, actually take place in the Brain, as in the “dark part” of our brain, which lies in the skull. **AND BEYOND THIS SCULL, AS WELL.** But what lies beyond the scull, unfortunately, is not clear to the absolute majority of people, and, of course, to representatives of the "modern science", who try to convince us that they are closely engaged in the problems of the Brain with all unlimited technical potential. But – the Brain remains for them an unknown territory – *The Brain in our view or imagination, or touch does not exist; we can not examine the Brain under a microscope, cut it with a scalpel; we do not know what the Brain is.* But this should not stop us from wanting to know! And we

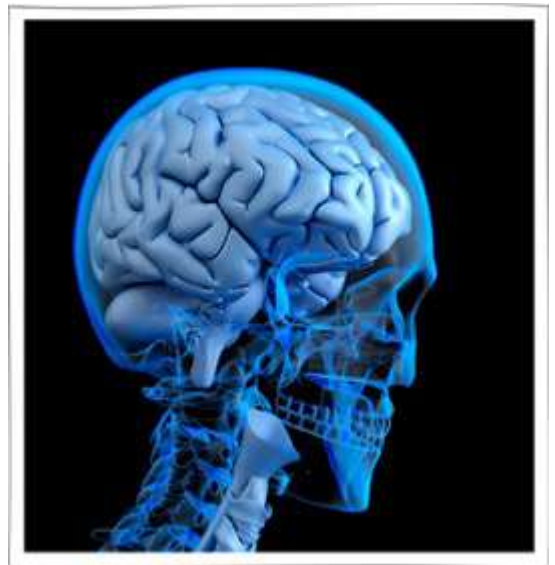

already have an idea that Man is one of the structures that has the Brain, and far from being optimal. The human Brain is a complex structure that controls every cell in the body. The control is carried out by ***gravitational-magneto-electric impulses, magnetic impulses, strictly quantized magnetic and electric potentials***. The Brain Control is carried out from another space. When communication with the Brain is violated man dies. Communication with the Brain can be broken in many ways, including using sounds (or music). **The Appendix** to this chapter gives the frequencies of the organs communication, regulatory data for a living cell depending on the genotype and their response to the sounds and musical components of an atom. If the readers remember, I said that I would be happy if I cognize ***"the physics of the Brain, the physics of the Cell, and the physics of Energy"***.

Let's now analyze not that easy information. When we say "We see", we actually mean the effect produced in our Brain by light rays, in accordance with the frequency spectrum formed in a particular place by the Life Support System (which I mentioned earlier); they reach our eyes and form electrical signals. Saying "We see", we only "observe" the electrical signals that occur in the Brain. One more fact should be taken into account – that part of the Brain which instrument are the eyes, being in the skull, is absolutely impenetrable, and pitch darkness is all around. Direct contact with light of this part of the brain is impossible. For clarity, let's imagine that we have a burning candle, and we see the light of its flame, although we perceive the light of the candle by that part of the brain that is in the absolute darkness of the skull. The light of the candle does not illuminate either the brain itself or its "visual center". Nevertheless, we visually perceive the bright and multi-colored world inside our dark brain.

The same thing happens with the rest of our senses: sound, touch, taste and smell are perceived by the brain only in the form of electrical signals in a specific frequency spectrum of the Life Support System. Thus, our Brain throughout our life **DOES NOT HAVE A DIRECT CONTACT** with the initial matter that exists outside of us. It deals only with its electrical copy, formed in the brain. It is here that we are misled, assuming that this copy is real matter, objectively existing outside of us. Then it turns out that the outside world is inside our Brain, is not it? The above brings us to the undeniable conclusion: our vision, hearing, touch, smell, taste, taken by us for matter, the objective world or the universe, in fact, are only electrical signals that are formed through the senses in our brain and are transformed into an image.

For example, we see a bird in the outside world. In fact, this bird is not at all in the outside world, but inside our brain. Light particles, reflected from everything that came their way in space (and transformed in accordance with the characteristics of the reflecting surface of this object), fall on the retina of our eyes, stimulating formation of various (according to their own structure, slightly modified by reflection / absorption) electrical impulses. These signals through nerve endings in the ocular fundus are transmitted to the visual center of the brain. The bird that we see is, in fact, only an electrical signal in our brain. If the ocular nerve leading to the brain breaks off, the image of the bird formed in it immediately disappears. In the same way, the sounds of the singing birds that we hear are in our brain. If the nerves from the ear to the brain were broken, there would be no sound. To put it simply, the bird, the appearance of which we see and the singing of which we hear, is nothing more than a **DECODING OF ELECTRICAL IMPULSES COMING INTO THE BRAIN**. But this is rather simplified conclusion, which, however, gives us at least some understanding possible with the current level of the Brain development.

Another point that will be touched on in this connection is *the perception of distance*. By the way, the distance between you, for example, and the screen on which the health Improving Session is played (and, of course, not only the session, but everything that is played on the screen) is nothing more than the **FEELING OF EMPTINESS, FORMED IN YOUR BRAIN**. Similarly, objects that seem very distant from the point of view of man are, in fact, images that crowd in the same tiny area of the brain. For example, a person who watches stars knows that they are at a distance of millions of light years from him. However, in reality, the stars at that very moment are inside him in the "visual center" of his brain. While you are watching the Session, you are not inside that room in which, as you think, you are sitting and looking at the screen. On the contrary, the room is inside you. The fact that you see your body in this room makes you think that you are inside it. However, it should be remembered that *your body is just an image formed in your brain, EXACTLY YOUR BRAIN*. This is the basic in our thoughts.

So far, we have been talking about the external world and the world of perceptions, which is formed in the Brain and creates our ideas about this world. However, if we are not able to reach the outside world, in its full understanding, due to a limited (to put it mildly) developed Brain (depending on the genotype), can we be sure, exactly from these positions, that it really exists? Of course, not. The only reality which we deal with is the

world of perceptions, existing only in our consciousness. And this is the result of exactly what was “done” to our Brain at the stage of its development and in the direction of its development by those who came to our Earth. The famous philosopher **John Barkley** commented on this stunning conclusion: "***We believe in the existence of objects just because we see them and feel them the way our brain reflects them. However, our perceptions are only thoughts that exist in our brain. If all these are only thoughts in our consciousness, then***

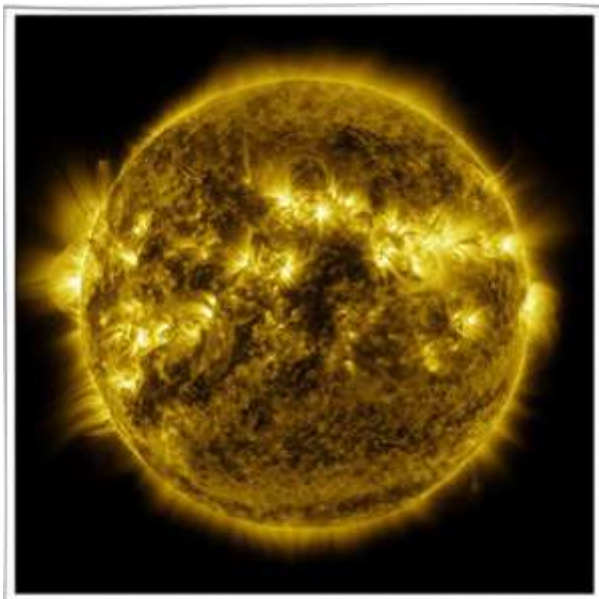

imagining the Universe and matter as realities that exist outside of our consciousness, we fall into a big delusion... " By

making the information received through our senses absolute, we immediately divide the world. ***But the world around us is a single whole*** (and not something separate material and separate ideal), and **IT IS EXPRESSED BY DIFFERENT SETS OF FREQUENCIES**, and the entire development of life on the Earth is determined by the frequency

dependencies (formed by the difference of two numbers of the Solar system). The Solar system produces the entire spectrum of frequencies supported by the potentials for the existence of all that was created on the Earth. All this frequency spectrum becomes accessible at any point of the Earth through the active zones – ***the Hartman, Curie, X-ray nodes***. Thanks to them, each layer of the multi-layered structure of the Earth's Atmosphere has ***its own grating and frequency spectrum***. This significantly affects the ability of the Brain in all aspects of its "activity" and depending on its location, and on many other factors related to the Life Support System. Let me remind you that the lower layer of the atmosphere contains ***more than 100,000 frequencies***.

The reality for us is that you can touch it and see with your eyes. In a dream, you can also touch with your hands and see with your eyes, but in reality ***you have neither hands nor eyes*** with which you could touch and see. However, taking your sensations in a dream for a material reality, you are just deceived in our today's understanding but these are realities, on the one hand, and on the other hand, it is something imaginary and desired

by our Brain. For example, a person who is fast asleep in his bed can see himself in a completely different world in a dream – this is absolutely one thing that happens to the Brain. Or he may dream that he is a pilot and is guiding a big passenger airliner – and this is completely different. But in fact, this man did not make a step from his bed. In dreams, he can visit various places, meet friends, chat with them, eat and drink, and even despite the fact that these are just sensations without any material correspondence, they are experienced as a reality. Only after waking up a person realizes that **THOSE WERE JUST SENSATIONS** – this is how most of us see it. But much of the "seen" in sleep is in fact the reality in which the Brain took part. Of course, one can speculate this way: – if we can easily live in the unreal world of our dreams, then this applies to the same degree to the world that we experience in reality. There is no logical contradiction in the assumption that when we wake up, we just move to a longer sleep, which we call real life. The reason why we consider our dreams to be a fiction, and the outside world a reality, *lies in our habits and conventions*. From this it follows that the day is not far off when we wake up from the earthly life that we think we live in now, in the same way as we wake up from sleep every morning. And this is one more reason why I took up the technologies N. Levashov had left me, and began to "put myself to test" when creating the Session, which today has a very serious effect on all of the above, carrying a lot of nuances in development and improving the User's health.

However, who then perceives all this (the real world, the world of dreams and other realities)? As it is already clear from the above, there is no doubt that the material world called the external one and seemingly real, **IS FORMED IN OUR BRAIN**. But here a reasonable question arises – if everything material is simple perception, and then what is our Brain? Judging by the fact that our brain, (like our arms, legs as well as other parts of the body) are considered by science and believed by people, are the same matter, then the Brain must be nothing else but perception. Let me explain this with an example. If we could stretch our nerves and take the brain out, placing it outside the skull so that it could be in the field of our vision, then we would be able to see it and touch it. Thus, it will become clear that our brain is just a perception formed by the senses of sight and touch, smell, etc. Where, then, are the will and mind which can see, hear and perceive all other sensations, if it is not the Brain? Who sees, hears, perceives, and feels taste and smell? What kind of being is it that thinks, reflects, and more than that – says: **"I am Me"**?

Obviously, this "being" able of seeing, hearing and feeling is something more perfect than matter. This "being" is alive and is not matter or image, but the Spirit (Soul, if you like, or the Brain, outside of our everyday concept of the word "brain"). And what we call the material world is a set of perceptions visible and experienced by the Spirit, as Nicolai Levashov used to say about it, and it is difficult not to accept this. Just as our body and the entire material world do not exist in our dream, so they do not exist in the real world either. In reality, there is only the Spirit. The matter consists only of the images brought by the Spirit. Even if we proceed from the premise that matter is real, the discoveries of modern physics, chemistry and biology will lead us to the conclusion that matter consists of images, and we have to recognize the reality of a certain metaphysical substance that exists along with matter. Thus, it will logically bring us to the unsolved, which is hidden behind matter. This fact is so logically and scientifically substantiated that it inspires fear among a number of scientists materialists, who consider matter to be primary and unchanging. Let me remind you – today ***we know no more than 5–10 % of matter, and the remaining 90 %, for our convenience, are called "Dark Matter"***.

All these facts examined by us put us face to face with a conceptually important question: if what we call the material world consists of only perceptions of this Spirit, then where is the source of these perceptions? When answering this question, we must think of the fact that matter does not exist by itself and does not control itself, but is just perception. Therefore, this perception should be brought by some other force, that is, it must be created. Moreover, this process of creating images **HAS TO BE CONDUCTED CONSTANTLY**, because if there were no constant and continuous process of creation, then what we call matter would disappear and dissipate without a trace. This continuous process can be compared with any TV, on the screen of which the image exists exactly as long as the broadcast signal is transmitted from the television center. As soon as the broadcast is interrupted, the image from the screen disappears. I made all these conclusions after I started developing the Health Improving Session. But they are based on the knowledge gained from the works of ***N. Levashov, A. Khatybov and other Russian scientists***, whom I constantly mention in my books. I do not pretend to be true in this complex issue; I have no doubt that there is another vision. But it was this understanding that allowed me to solve the tasks that I had set for myself. In addition to philosophical reasoning, I, of course, will present the reader with

more substantial grounds and calculations, which were applied and formed the basis for understanding what should be done.

7.5. Render to ear what is ear's; to sound what is sound's

Now, about sounds, music., music of an atom, and, of course, for completeness – about the musicality of chemical elements. But I'll start with a musical ear. Why? Because ***the size of the ears*** (the more the better) ***does not affect the ability to listen and hear***. Man has everything necessary for listening to music of atomic structures – the spine and the Brain. What is not audible in an explicit form can be listened to by other structures (ears are attached to listen to the news). ***There are 13 types of musical ear*** that allow you to fully perceive music and objectively appreciate it. Here I just name these types, because it is important for understanding. It is not necessary to give characteristics to all of them, it's not difficult to figure it out on your own:

inner hearing is the ability to mentally imagine a piece of music, a melody and individual sounds, to "hear" them in your head. As an example – the genius Beethoven, who, having lost his hearing, continued to write musical works, perceiving their sound only by inner hearing. With



absolute pitch, a person has a special memory for the exact height of a musical tone (the frequency of vibrations of a sound wave). ***The remaining professional types of hearing: relative or interval hearing, pitch, melodic, metro-rhythmic, harmonic, modal, polyphonic, timbral, dynamic, textured and architectonic hearing. Each person has*** all these types of musical hearing, but ***NOT ALL OFF THEM ARE DEVELOPED EQUALLY WELL***. Of course, it is impossible to completely deny the level of natural abilities in the development of varieties of musical hearing, but any person can achieve the highest results in this direction with regular purposeful studies on the development of hearing with the help of, for example, solfeggio. But very few people are engaged in this.

Certainly, I was interested in the **Architectonic hearing** – this is the feeling of the form of a musical work, the ability to determine **DIFFERENT REGULARITIES OF ITS STRUCTURE** at all levels. With the help of architectonic hearing, one can capture the way motives, phrases, sentences are assembled in one form, as the building is composed of bricks, slabs and blocks. This feeling of a large musical form lies in the ability to perceive a volumetric musical work and a large, long-length musical work as a single whole. This one of the most difficult types of musical hearing verges on the creative musical thinking. It is not by chance that for the young musicians in the exam it is mandatory to perform a major work: a concert for piano and orchestra or a complex sonata.

The feeling of a large form is akin to strategic thinking in business or, for example, in war. You can be an excellent businessman, be able to negotiate with people, i. e., to have business tactics (performing technique), but if you **ARE NOT ABLE TO EVALUATE CORRECTLY** your product or service (you cannot feel the essence of a piece of music), correctly target it to your market segment (assess the adequacy of the work for the audience), realize your competitive advantage (to find your individual style of performance and interpretation of the work) and create a business development plan for at least the next thousand years (according to **Woland** – a character from the novel by Mikhail Bulgakov "**The Master and Margarita**"), then you will lose. The same is in music. You can play pieces very well. But you have to generally feel the distribution of the roles of musical parts and phrases – look at the large musical work as if from above, that is, have a strategic vision. Many musicians do not possess it. But there are millions of kinds of music and that's enough for everyone. Architectonic hearing follows the coherence of development and mutual conformity, the proportionality of the parts of the musical form. It **CREATES MUSICAL HARMONY**, keeping up with the proportionality of the parts and the whole, picking up the patterns of the musical form structure at all levels. If this form is harmonious, then our Brain perceives it as a kind of law, where everything is exactly as it should be. Harmonious things are generally perceived as very simple, natural, understandable – but try to create such things yourself! Among ancient Greeks, the "law" and "melody" were defined by the same word "nomos", emphasizing the highest regularity contained in the melody. Architectonic hearing is closely connected with the art of architecture, where the harmony of proportions, beauty and mathematics are inseparable.

Now, taking into account 13 different types of musical hearing (no matter which types you have, readers), let's consider the sounds, and preferably "all of them". We define a sound in two terms – as a physical phenomenon and as a sensation. Speaking about the physical side of the phenomenon, we characterize the sound by its intensity (strength), its composition and the frequency of the vibration processes associated with it. Having in mind sound sensations, we are talking about volume, timbre, pitch. Musical sounds are distinguished from other sounds by the fact that their frequencies are interconnected by ***certain proportions – harmonics***. The same proportions can be observed in all the variety of natural phenomena ***from the cell and plants evolution to the planets movement around the Sun***, that is, in fact at all levels of dimensional scale, up to the Universe, and in the man-made world – in architecture, arts, and mathematics. Melodies, raising the spirits are composed of different notes; a wonderful poem and an exciting story – from different letters; an amazing artist's canvas – from different colors; the splendor of nature around us – from different forms, types of flora and fauna ... All their components are different, but connected in a special way, called harmony, they are able to work wonders.

Music is not only present in our life – it also demonstrates the processes hidden in us, which our Brain can either organize into a coherent picture, or let it go into free uncontrollable floating. ***He that heareth, let him hear***. Man, as a world musical instrument, does not create great thoughts, ideas and insights, and you already know this. The Brain only allows something to enter it and speak with its mouth. Therefore, do not think about what to write, how to write and whether something brilliant will be written. Let something say something through you about something. For



example, ***Sergei Danilov*** always did that way – when speaking in public, he let "the talk go through him", and we always discussed it when he came to visit me. He never prepared his speeches. The main thing for him was to start and, as he put it, "then it just flowed out of me..." But in order for that to happen, keep your instrument in order. In fact, every man is a

musical instrument. ***Your instrument must be tuned and not broken.*** And in this tuning the "tuning fork" are the ***"SvetL" Programs.*** It is important for a person to understand what kind of "musical instrument" he is, **WHICH SOUND HE WANTS TO SOUND.** You can't want to be a violin if you are a reed pipe. And vice versa, you cannot make of yourself a reed pipe if your mission is to be the largest regimental drum.

In the Universe, all the most perfect and most expedient is some kind of orderly and embodied "likeness of everything in everything and everywhere", somewhere or in something even brought to the highest level of civilization perfection, and only after that is "applied" by its expediency in the most responsible links of the most perfect natural being, that is, in something else and very important, but less or more large-scale. That was once the **Human.** And today He is moving into the state of his active former being on a certain scale and in the territories of the functionally endowed for this process since this year 2019 (since January, 19). This is what is important for our understanding of the ongoing. It is not me who says it, it was said through certain people, just as through S. Danilov, "it was said." And the translated "music of Cosmos", given to us from the above with the help of Pulsars, is for us one of the gifts of the given elements of the life support part; however, without our Mother Earth, we are not yet suitable for such miraculous "melodies", because we have neither "an ear" nor "hearing" for this!

But without such a "musical translation" and the ability to decode it, on our planet it would be impossible to form Intelligent, I emphasize here, ***not potentially reasonable, as we are now, but Intelligent orientation of the Civilization development of Mankind, the Brain of Man and the Earth as a whole.*** The Brain of people possesses some special "Solar" technological similarity of compounds that distinguishes us with our Brain from all other representatives of any other civilizations, no matter how many of them there are in the whole of the Universe. So far our Brain can work **ONLY WITH THE MANDATORY ENERGY – INFORMATION SUPPORT** from the objects of the Sun and the Earth simultaneously. ***So, the translated "music of Cosmos",*** given to us from the above with the help of Pulsars, is for us one of the gifts of the **ELEMENTS OF THE PART OF THE LIFE SUPPORT.** Once again I would stress that without it on our planet it would be impossible to form an Intelligent orientation of the Civilization development of Mankind, the Brain of Man and the Earth as a whole. That is such a mandatory "musical" literacy; so, more often turn to, at least, the living music classics, and, no doubt, you

will be much "healthier" and more perfect. But this is common in the recommendations, and specific and purposeful is Beethoven's *Moonlight Sonata*, which is the basis of my experiment.

I compare Man with a very complex, unique and finely tuned musical instrument. Every atom, molecule, cell, tissue, and organ of the body constantly emit the frequencies of physical, emotional, mental, and spiritual life. The correspondence of the musical sounds frequencies to the structure of human tissues and organs, and the musical rhythm to the rhythms of the vital activity processes leads to the fact that music has a very deep and many-sided effect on the principle of acoustic resonance on all the functions in the human body, as well as on emotions, desires and feelings. Without being accompanied by information and control, not only we, but every cell of our flesh cannot exist at all. The collection of a great number of cells of our flesh is somehow close in the obligatory presence of the elements of their construction; but I remind you that **THERE IS NO REPETITION** of their functional endowment for each cell – it is strictly individual. And, accordingly, each organ of the "internal secretion" works in a certain frequency range of energy-informational support during its activity control process by the Brain. That is, as if "actively existing", it also sings only its own "melody", without interfering with the "song" of other organs, and at the same time "listening" to them as to the common choir. All that is in music – it lives in Man.

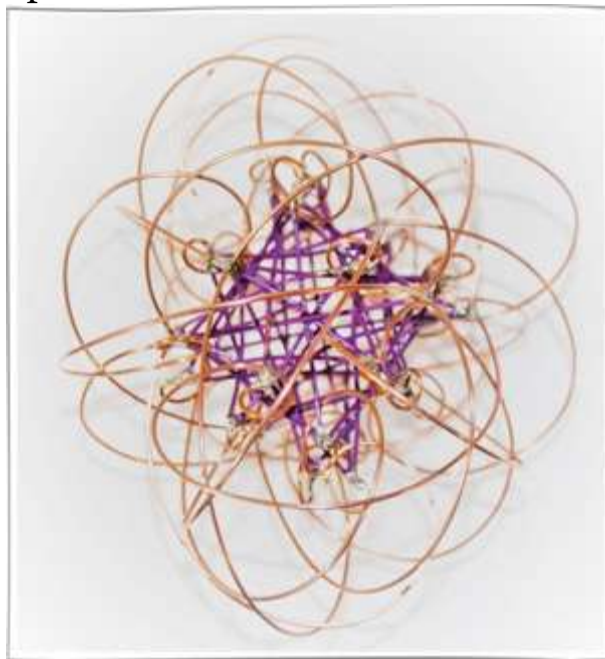

Pulsar's model photo (Construct stellate triandrosiohedron)

The musical octave, built in line with the laws of the golden section, reflects the harmony between the sounds and frequencies which a living organism "speaks". The connection of a musical instrument with a human body can be simultaneously both symbolic and instrumental (a model for making an instrument). ***The body can be thought of as an instrument, and the instrument as the body.*** The sound of a voice is likened to an instrument or, on the contrary, the sound of an instrument can imitate the voice, be in symbiosis with it or be opposed to it according to the

principle of binary opposition⁷⁶. In principle, it is the body, taken in the dynamic aspect (movement), is the source and model of the organization of the sound matter, since it contains basic rhythms – pulse, breathing and walking rhythms, permeating both working and aesthetic activities of man. ***In man, there are all kinds of musical instruments in a complex combination.*** There are strings – our vocal cords, which the strength, volume, pitch and timbre of the voice depend on. There are drums – the tongue makes rhythmic beats on the teeth, cheeks and palate, does the same thing as drum sticks; and, of course, we have the wind instrument – respiratory organs: lungs – organ mechs, diaphragm and trachea – for air movement. Of all musical instruments, **ONLY A VIOLIN IS CLOSE TO** the subtleties of the human speech apparatus. All the others do not resemble a man's voice. But a person who sings a cappella⁷⁷ always sings better than any instrument.

In the dance, the whole body can also sound, for example, as a percussion instrument in the Russian tradition: stomping figures, beating with hands on the knee, on the ground, on the shins, on the head, on the cheeks, spinning around oneself. The rhythm can also be beaten on all sorts of sounding household utensils – spoons, a furnace damper, a bucket, a trough, a saw, etc. With the help of a musical instrument, there is "amplification through duplication" of precisely those parts of the body that already have the ability to sound making. The tools, being natural, but at the same time "humanized" bodies, pave the way for "curbing", ordering, transforming natural sound elements into aesthetic (musical) human activity, realized through one's Brain, and mark his transition from natural to cultural space. Therefore, in ancient times, wise men considered music to be sacred art, the seeing can see the picture of the world in it, and in the field of music, the wise can explain the nature of the Universe work. The creative vibration, which different sources of antiquity call differently: Word, Logos, Shabd, Music of the Spheres, etc., is movement, vibration energy – it always sounds. Replacing the word "vibration" that has an esoteric tone with the well-known and common word in modern society "frequency", comparing the information we have already known with the information of "the initiated

⁷⁶ The binary opposition is a universal means of rational description of the world, where two opposing concepts are simultaneously considered, one of which asserts a certain quality, and the other denies. It is considered an essential quality of thinking, opposed to various forms of intuition. The roots of the idea of binary oppositions go to Plato's dialectic and the formal logic of Aristotle

⁷⁷ A cappella – as a rule, choral singing, without instrumental accompaniment, in demand in folk music

wise", we feel its new meaning, and the views of Greek philosophers – fundamentally correct.

7.6. The note of silence in musical education

There lived a musician who played music with such virtuosity that people said that he could find his own melody for each person. However, the musician was unhappy. "It cannot be", he thought, "that there are only seven notes in the world. There must be at least one more..." The musician went to see the best music masters, but they all just shrugged their shoulders. "*There is no eighth note*", they said, "at least we don't know it". The musician himself tried to extract this note, but his attempts were unsuccessful. Once the musician heard about the Zen master who, as people said, could solve any problem. And the musician went to see the master.

Yes, – said the master, after listening to the musician, -there is note eight. More precisely, it is the very first.

– Show it to me, master! The musician exclaimed.

"You yourself know it", answered the master, "that's all, go, I don't have time for idle chatter".

The happy musician left the master and again tried to find this mysterious note eight, which was the very first. Unsuccessfully. The musician again went to see the master of Zen.

"I couldn't find it", he said.

"You don't have to look for it", the master answered. "I have told you, you already know this note". Just so far you have learned to make music, but now you have to learn to listen to it.

The musician abandoned his instruments and began to attend the performances of other musicians, trying to hear a new note in their music. However, he still did not open a new note, but he heard a lot of great music, which, as it turned out, he had never heard at all.

"You have taught me to hear music", said the musician, once again coming to the master's.

– Did you find note eight? – asked the master.

"No", said the musician, "but I..."

"So I'm wasting time with you", the master interrupted the musician and with a wave of his hand sent him away. A few days later the master himself summoned the musician.

– Tomorrow important guests should visit me. I would like to ask you to play for them.

The musician agreed.

"I have only one request", said the master, "you should start playing only after I wave my hand". It is very important.

– OK.

The next day, the musician came to the master's

He prepared the instrument. The master's small room was already full of people, but the guests were still arriving. The master greeted everyone, asked about their health and seated everyone in a certain place. The guests looked curiously at the musician and talked loudly. The musician was waiting. Finally, everyone sat down, and the master began to tell the guests the famous parable about the emperor. He told "tastelessly", and the guests did not listen and continued their chattering, so that in the general noise the master was hardly audible. The musician was waiting.

Finally the master announced the musician. In the room silence fell immediately. The musician prepared himself with his fingers on the strings. The master raised his hand and suddenly froze like a stone idol. The guests were rooted to the spot in a variety of poses. The musician also froze in the anticipation of the master's hand waving. Silence reigned; even breathing could not be heard. The musician looked at the master and involuntarily was listening to the silence. But the master stood still without stirring, as if he really was just a stone statue. The musician did not breathe in, not daring to break the stillness of the room And the stillness was so absolute that it became a sound.

"This is the note of silence and of the loudest cry. The note of silence and all words. The note of emptiness and knowledge ...note eight you were looking for..."

The musician bowed to the master and left the room in complete silence.

* * *

The parables about the musicians who were looking for note eight, its mentioning in some legends, ballads, songs and folk tales handed down from

generation to generation, only confirm that people knew or supposed its existence. **"There is no fire without smoke"**. Information about note eight (despite the fact that it was isolated by the interventionists and removed from their command system) did somehow leak, rather, from those people whose brain the System was not able to transform while creating the planned genotypes. **WITHOUT THIS NOTE (note Na)**, there will be no complete form of a piece of music under the new conditions of the changing environment. The musician's architectonic hearing made him look for this note.

We, living in the 21st century, like the ancient initiates, are talking about the same things, but using different words that hide from us a clear understanding of their teachings. What is everything made of? Of what that they and we are surrounded with: earth, water, air, fire, and vacuum, they thought. But we know that the World is created of atoms – small bricks, with the help of which both the earthworm, the fragrant rose, and all the rest are created. All this could be a brilliant guess, and could be the scraps of knowledge of the destroyed earth civilization and, most likely, this is exactly so. Time is going on, and Humanity is gaining experience, especially now, by accepting the "translated" information flows of the Earth Control System (ECS), the ability to understand and correctly use the information received (and here not the last role is assigned to the **"SvetL" Programs**) and communication with Nature. This process will never end.



The world is material, and matter, space and time are infinite. At the current new stage of knowledge of materialistic idealism, the Russian scientist **A. A. Luchin proved by the divisibility of an electron that only two particles are enough to build our entire world:** a photon and a magnetic particle. All the other observable particles are integral formations of the two mentioned. At the dimensional atomic level, the photon and magnetic particle, which are usual for our awareness, are like "world-forming first-bricks" forming both an atomic nucleus and electrons, and thus a model embodiment of the process of constructive transformation takes place, and

more precisely, bringing to order various types of matter followed by the controlled behavior from atomic level and higher, as one of the functions of the Existing being. And if you look into the very structure of an atom? Already from the works given to us by other Russian scientist, **A. M. Khatybov, an atom, having musical education**, is a whole system built according to the laws of harmony, which creates all the varieties of elements on our Earth and thanks to which we perceive the surrounding reality. It turns out that the pleiad of the most ancient Greek scientists — Pythagoras, Socrates, Plato, Aristotle, Democritus, Hippocrates, Archimedes — passed their tradition to the Russian scientists Morozov, Levashov, Khatybov, Luchin and others, twisting their deep roots in understanding natural processes. Take at least Pythagoras. In his philosophy, color and sound are integral parts and an expression of the Universe harmony. Harmony was considered by him as a state preceding beauty. Pythagoras derived the mathematical laws underlying musical harmony, that is, he discovered the diatonic scale of musical intervals. The mathematician reflected the obtained ratios of numbers forming intervals in **Tetraktys**⁷⁸, or a pyramid of 10 points. The Pythagorean triangle subsequently became for the Pythagoreans the supreme symbol of universal forces and processes, and for me — the impetus for creating the new "**Complex Di**" and new programs for it. I

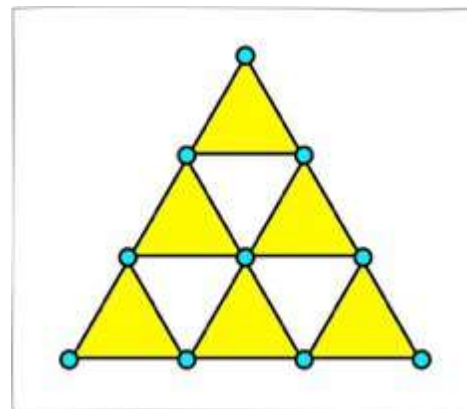

found in **E.P. Blavatskaya**⁷⁹, in her book "**The Secret Doctrine**", more than an exhaustive explanation regarding this construction — "These celestial fruits of Sephiroth, ten in number or $\textcircled{10}$, **10**, born from two invisible seeds, male and female, **form 12, or the Dodecahedron of the Universe**. The mystical system contains the center point; **3**, or \triangle ; **5**, or \star ; and **7**, or again \star ; a triangle squared and a synthesis point in two intertwined triangles. Such is the case in the World of Pre-images. The Phenomenal World reaches its culmination and reflection **of all that exists in Man**."

⁷⁸ The Theon of Smyrna argued that the Ten Points or Pythagoras Tetraktis were symbols of great importance, because they revealed to the sharp mind the secret of Universal Nature.

⁷⁹ Elena Petrovna Blavatsky (nee Gan, German, July 31, 1831 Yekaterinoslav, Russian — April 26, 1891, London, England — Russian noblewoman, US citizen, theosophical religious philosopher, writer, journalist, spiritualist, traveler. Blavatsky declared herself the chosen one of "A great spiritual beginning", as well as a student (chela) of the brotherhood of the Tibetan mahatmas, whom she called the "guardians of secret knowledge", and began to preach the author's version of theosophy.

Therefore, in its metaphysical aspect, it **is the mystical square – Tetraktys**; and becomes a Cube on the plane of creation. Its symbol is a developed cube, and **6** becomes **7**, or, , **3** horizontal (feminine) and 4 vertical; and this is man, the culmination of the Divine on the Earth, whose body is a cross of flesh, in which, through which and on which he constantly crucifies and brings to death the divine Logos, or his Higher Self". The key for me here is "**...form 12 , or the Dodecahedron of the Universe...** "

You see how everything is intertwined both in understanding and in the reflections of the ancient and modern thinkers mentioned above. But! It should be taken into account, however, that the True point of the Conceptual Power is not a matter of the human mind. Any attempts by researchers of this issue to understand, as a rule, drown in the web and mists of the actions of secondary performers "of historical scenery". They themselves always acquire the state of such depression and enthusiastic dying out from the level or influence on them of the degree of excessive mystery and unusual elevation from the fact of touching with something inexplicable, which necessarily introduces them into the sphere of "sacred" dedication. After such "research", participants often overnight become no less than "initiates", and sometimes even direct "rulers" at the level of Conceptual power (N. Roerich, J. Blumkin, E. Blavatskaya, F. Dzerzhinsky, M. Bulgakov, etc.)... All those individuals of a single or group plan who were really, and not according to some legend, involved as true executors for the preparation and manifestation of the ongoing or future events could never be in a state of publicity and now it is clear that is objective. So you can use their works only with a deep understanding of what they wrote about. Of course, there was some rational grain there. In addition, I consider it necessary to advise you to see at N. Levashov's and understand what he said (wrote) about N. Roerich and E. Blavatskaya.

For Pythagoras, music was derived from the divine science of mathematics, and its harmonies were toughly controlled by mathematical proportions. He made music gain a reputation of an exact science and applied the laws of harmonic relations found by him to all phenomena of nature, going so far as to establish harmonic relations between the planets, constellations and the elements studied by him. In the same way, Pythagoras laid out the harmony of light, closely interlacing it with the harmony of sound. For Pythagoras, color is the same fundamental principle of the Universe as sound.

The picture below is inaccurate; there is no orange color of the rainbow in it, due to the fact that it is a demonstration of the CRT tube palette, and not a natural object. However, it gives some understanding of the issue in question.



There are various relationships that put in good order the interactions of the planets, colors, and musical notes. The most acceptable system is based on the octave law. Hearing has a wider scope than sight. While the ear can record **nine to eleven octaves**, the eye can register **nine fundamental color tones — one tone more than an octave**. Red, thus being the lowest tone in the color scale, corresponds to "DO" – the first note of the musical scale. Continuing this analogy, orange corresponds to "RE", yellow to "MI", green to "FA", cyan to "SOL" blue to "LA", and violet to SI. The eighth color tone is the medium of existence of all the others, by mixing all the colors, a white color is obtained, and it corresponds to **the eighth note NA**. The ninth color tone – Black represents **the lack of light**, in the meaning of cosmos, and corresponds to the musical (9-step) interval of **NoNa**.

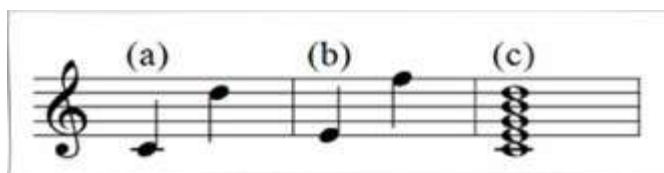

The accuracy of the above analogy is confirmed by two circumstances: the three fundamental notes of the musical scale – the first, third, and fifth – correspond to the three primary colors – red, yellow, and blue; the seventh, less perfect note of the musical scale corresponds to the violet, the least perfect tone of the color scale. And this conclusion turned out to be extremely important when building the soundtrack of the color scale (this is the color-accompanied work of the "SvetL" Programs specially selected in the Session). However, it turned out that a conclusion can be made the other

way round – the construction of a color scale within the framework of the applied musical work. Here we are talking about *L. Beethoven's "Moonlight Sonata"*, because this is one of the few musical works in the world that carries the note "Na". That is why I took this work as the basis for the creation of the Session, which is able today to do a lot in matters of improving human health. My friend and colleague, *Andrei Rekhtin*, helped me invaluablely, who brought this regularity in understanding note "Na" and the musical interval "NoNa", and who wrote, in my opinion, a wonderful work⁸⁰. Why do I focus on note Na? Let me remind you that in the chapter *"Atoms do not live alone"* I wrote in detail that the interventionist system *had used the old musical literacy in 12 semitones: DO v1 RE v2 MI FA v3 SOL v4 LA v5 SI* (which corresponds to the musical *series of 7 notes* with the addition of 5 semitones). The invaders retained the base, **removing note NA**, but added semitones. The question arises – why did they remove **note NA**? The point was to remove the boundaries of the medium of existence (**note NA**) in order to have direct access to the object of impact and manipulation in the process of creating certain genotypes of the Brain and **TO AVOID PROBLEMS** aimed at achieving the specific results rather than returning them at the first stage of development to the initial state in which the individual had been before the Ebr intervention. Note **NA** creates a structured harmonious medium instead of an amorphous one. After "recognizing" the interventionist experiment result as "failed", since **2007 the Russian musical series – 8-note (DO, RE, MI, Fa, Sol, La, Si, Na)** has been returned to the planetary control system. Built on octave **DO–NA** octave, it is used today to control the Brain, but, most likely, for its further development, or its "nulling" in specific Brain genotypes, which is observed in the actions and decisions of today's so-called "ruling elite" and not only them. **With the help of this particular system, the connection with the Brain is decoded. Three levels are used for communication, there is no need for alphabetic processing.** And, as I wrote in previous chapters, *tone NA is very dangerous*. With the appearance of such a tone lately (for individual Brain genotypes), there observed a sharp decrease in vision, a change in the grating of vision, a shift in color perception, etc. When the electric potential of the magnetic impulse reaches 21%, the resonator is unlocked and its operation stops, which automatically leads to death or the Brain disconnection from the ionic

⁸⁰ A. Rekhtin "The Heretical Look before Na_Chala, and the Law of Nine."

structure. Naturally, any development of speech is out of the question. I note that in these cases **the "SvetL" Programs** are of "no help". They can only provide a **"COMFORTABLE" PASSING AWAY**. However, in a certain combination of **note Na** with other tones in the sound of musical works, on the contrary, the opposite effect on the Brain occurs with the restoration of the Brain functions lost or slowed down for one reason or another, which we use to solve problems of man's recovery and stabilization of his inner state (psyche, sleep, nervous break-down, fear, etc.). This, in fact, was demonstrated by the Health Improving session created on the basis of L. Beethoven's **Moon Sonata**, which ultimately contained the sound of **note Na** in appropriate combinations of tones in combination with the existing **"SvetL" Programs**, due to which the effect increased many times (as confirmed by many participants of **the "SvetL" Programs** who applied the Session).

Today, the "musical literacy" has been translated into Russian (4 octaves) in the framework of the Control Complexes operation in the Russian language. The Control is only software. The musical series makes it possible to encode and decode any information **in the 64-character alphabet** (about it – below), which comes today in full from the Native ECS, and apply control and cognitive programs within the life support system on our Planet.

Let me remind you that **THE SPINE RESONANT CONTOURS** of Man **are receivers of information**, each vertebra is a resonator of a given frequency and the corresponding musical tone – informational or control. The brain of each Man **contains a "Translator"** (sometimes several) for translating musical series received by the spine octaves or stored in the operational or long-term memory. Using the musical properties of the atomic structures of the Control System, information is received and transmitted with the control of the state of material and non-material structures. Each parcel is clamped in the frame; it contains the address, form of the execution and the text. All this was taken into account both when creating new Programs for the new **"Complex Di"** and for creating the Health Improving Session. But solution of the task of creating the Health Improving Session was, of course, the primary one. I described in detail in the previous chapters and in my articles⁸¹ the ratio of the musical scale, as the frequency characteristics of the human spine.

⁸¹ "Description of the object to be taken to the Bath" – Book 2 Ch. 4

7.7. To combine and bind

Understanding the physics of sound waves, vibrations of certain frequencies, musical scale, sound decomposition in octaves, intervals, tones, semitones, and much more in the world of music allows us to understand not only how with chemical vibrations of certain frequencies **CHEMICAL ELEMENTS ARE FORMED** (see Appendix to the chapter), but also how strictly certain combinations of their compounds, considering the law of form, make a man. Ultimately, this brings us to understanding cold nuclear Synthesis. These my thoughts bear a relation to the works of A. Khatybov, the information from which I cite here with my comments and additions, because, unfortunately, the most part of his works are still not public. However, I also learned a great deal from my talks with B. Makov, who was a friend of A. Khatybov.

Let us pay attention to the musical sounds that stand out among other sounds by their frequencies which are interconnected by certain proportions – harmonics. The same proportions can be observed in all the variety of natural phenomena from the cell and plants development to the planets movement around the Sun, that is, in fact at all levels of dimensional scale, up to the Universe, and in the man-made world – in architecture, art, and mathematics. These are simple and complex tones; noises (creak, knock, hum, howl, crackle, rustle, consonant sounds); blows (bang, blast). A simple tone is the sound of a tuning fork, its branches make harmonic (sinusoidal) vibrations with only one strictly defined frequency. Anharmonic vibration corresponds to a complex tone created by musical instruments and a speech apparatus (vowels and letters), which is a specific frequency spectrum. From the linguistic dichotomy⁸² of the **NOTE – TONE** root pair, it can be concluded that **NOTE** is a mirror graphic display of **TONE**. ***A tone is a sound, the background.***

And what did the musician do in relation to the sounds, although they are united and connected together? Using a few degrees from sound to sound, calling them Prima, Second, Third, Quart, etc., from degree to degree he established names for a variety of rises and falls of the sound. When the

⁸² **Dichotomy** – bifurcation, sequential division into two parts, more connected within than between themselves. The method of logical division of a class into subclasses, which is in the fact that the dividend concept is completely divided into two mutually exclusive concepts.

Example – The scope of the concept of "man" can be divided into two complementary classes: men and women. The concepts of "*men*" and "*women*" are complementary to each other.

frequency is doubled, the sound rises by an octave – it is for these reasons that the octave was chosen.

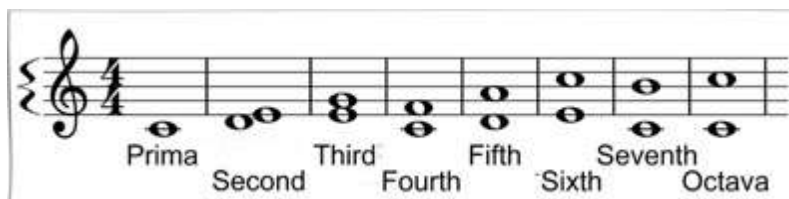

An octave consists of 7 notes and 5 semitones – **twelve** sounds, located at equal distances from each other, but only seven of them are the main sounds for the scale. Together with the fundamental tone of the harmonic (which in frequency 2, 3, 4 or more times is always higher than the fundamental tone), a number of sounds form a natural harmonic sound sequence or an overtone series.

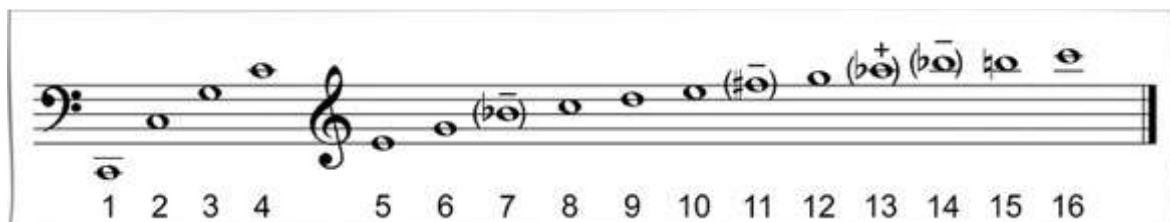

These are **16 sounds**, for example, from **note Do**, – a series of ascending partial tones, i.e. the main tone and overtones, the overtones of the main tone. Overtones are not perceived as independent sounds, they sound along with the main tone. The predominance of certain overtones determines the color, the timbre of the sound, that is, its quality that allows us to distinguish the sounds of one source from the sounds of others.

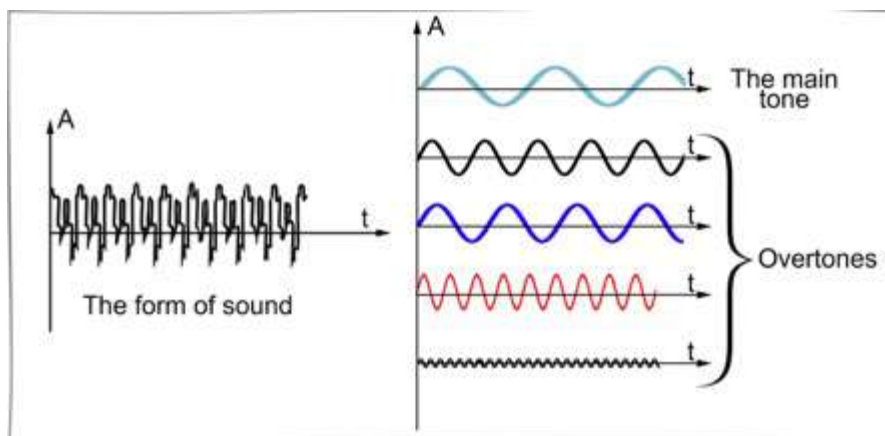

We **are interested in note Na**, which is present in the 8-note Russian musical series (**DO, RE, MI, Fa, Sol, La, Si, Na**). I talked to many musicians about their understanding of note Na. Some of them take it as absurdity, others looked with frank incomprehension – what am I talking about? And only a few began thinking of this and then tried to look into it. One of them is **Elena Arkhipova**, who I have known for more than a year,

a professional musician – a virtuoso violinist, our comrade-in-arms, believes that note Na sounds in many pieces of music, although **NO ONE EVEN SUSPECTS** about its existence. Using the example of a sounding violin string radiating a whole spectrum of waves with multiple frequencies, she expressed her understanding of **note Na** and drew the overtone sound scale with the main tone of **note Do**. The entire vibrating string is tuned to the fundamental frequency. The vibration fundamental frequency of the entire sounding body determines the basic pitch of the sound. But the main sound is accompanied by a number of almost elusive sound waves. This is seen in the figure below.

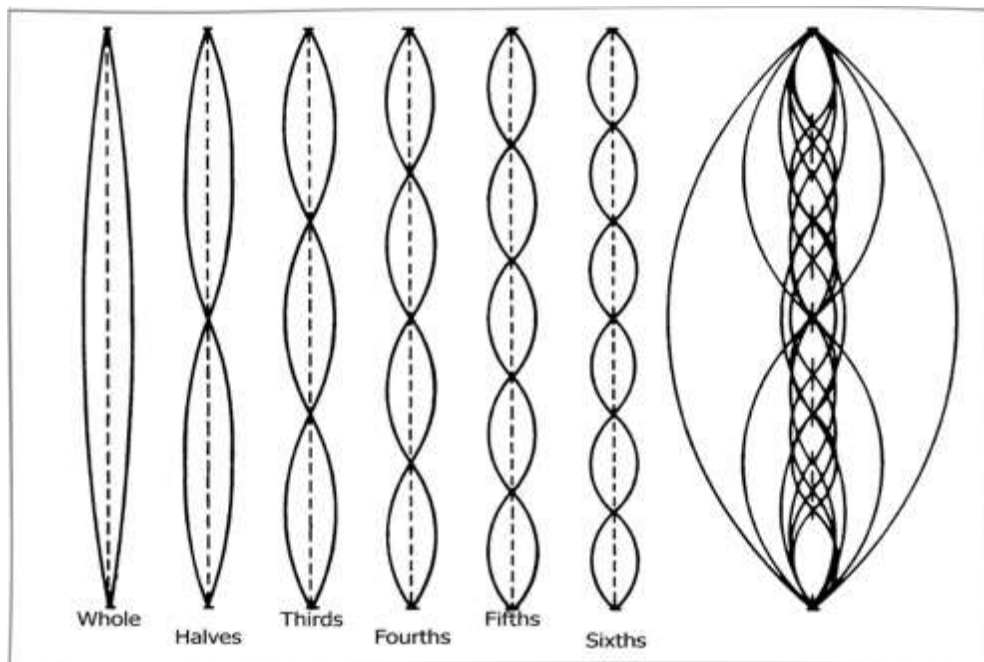

The most audible sound seems to be the only one. But the string vibrates not only by its entire length; its parts also vibrate: **halves, thirds, fourths, fifths and sixths**. All sounds that are the result of vibrations of parts of the string have a greater frequency of vibrations than the frequency of the entire length; therefore, all the sounds are above the pitch. String halves vibrate, give twice the number of vibrations – the sound is an octave higher than the main one. The tripled number of vibrations gives the fifth through the octave. A quadruple number of vibrations give the fourth – the sound is two octaves higher than the main one. $1/5$ of the string vibrations give three thirds, $1/6$ – give three seconds.

We know that sound, like a wave, manifests its properties and qualities **not only in the inertial world, but also in the non-inertial one. A sound is the transition of matter from one state to another, from one level to another.** Therefore, we hear not all sounds when the string is sounding, since they resonate and create vibrations at other levels of the

non-inertial mass of matter. At the simultaneous sounding of notes Do in the octave, note **Na** manifests itself – this, in Elena's opinion, is the eighth note in the musical series, which is the sum of vibrations of all (doubled, tripled, quadruple, etc.) sounds and additional sounds, of partial tones of the string vibrations containing the main tone and its harmonic overtones. I show you her "sketches" in this direction. And here she is absolutely right, because she almost unconsciously approached understanding the music of chemical elements (Appendix to the chapter). Note **Na** completes the full overtone sound sequence before proceeding to the next octave; that is the doubling of the fundamental tone with an octave higher. The wavelength of sound shortens and raises its frequency twice.

обертонный звукоряд

основной тон до

обертон

1/1 2/1 3/1 4/1 5/1 6/1 7/1 8/1

NA

обертон

большая октава малая октава малая октава первая октава

октава квинта кварта большая терция большая терция

колебания струны

малая терция большая секунда и т.д. по секундам

малая терция большая секунда

The combination of sounds (waves) creates a heterogeneity of the space at different levels of the Spirit's bodies and redistributes the primary matter flows without human consciousness. That was the main conclusion when creating the Session on the basis of **Beethoven's "Moonlight Sonata"**. By the way, A. Khatybov called **note NA a clock tone and a basic control one**. The main, basic tone here is tonality. And the clock tone is a certain frequency. **Note Na is the clock of the octave change**. Such octave doublings are widely used in music. On the example of the Moonlight Sonata, recorded at a frequency of **432 Hz**, we can hear it – the whole theme sounds in octaves. This is the sound **of Na notes**.

7.8. Musical series, an excursus into cognition

Let's make a little excursus into the music series. In symphonic music, with a lot of instruments and timbres, such composers (first of all) as S. V. Rakhmaninov, P. I. Tchaikovsky, M. I. Glinka and many others, of course, often resorted to writing music for different instruments with octaves. When listening to some musical composition, in addition to the form and drama of the work, the harmonic correlations of the sound waves of different ranges and pitch have an effect on the listener. However, I want to note that the octave numbering at each school is different. The French school of phonetics calls the big octave first, the small one – second, the first one – third, etc., and, moreover, it has all the notes a quarter of a tone higher, so to get them from the standard mantissas you should always subtract 0.044, and for **Lg₂Do** in this case, the result is always a zero mantissa (K, 000), which corresponds to the integer power of 2 (two full vibrations per second), whereas on the usual musical scale, 2.062 vibrations per second are taken as the starting point. However, let us consider the German system (Helmholtz) on the piano keyboard, based on the fact that Beethoven created his works in the German system. According to the German nomenclature, the raising in the basic tone by half is indicated by the addition of the syllable is (cis, dis, eis, fis, gis, ais, his), the lowering – by the addition of s or es (ces, des, es, fes, ges, as), the exception is Sub, denoted by letter B. To form a musical series of the "Maxim's table" (I remind readers that this calculation table is named after A. Khatybov's son, as well as a number of laws derived by him) A. Khatybov used the French system, and the sequence of vibrations was recalculated in a new scheme, which I also used. This scheme provides the entire set in each octave (do, re, mi, fa, sol, la, si), as well as semitones. Briefly

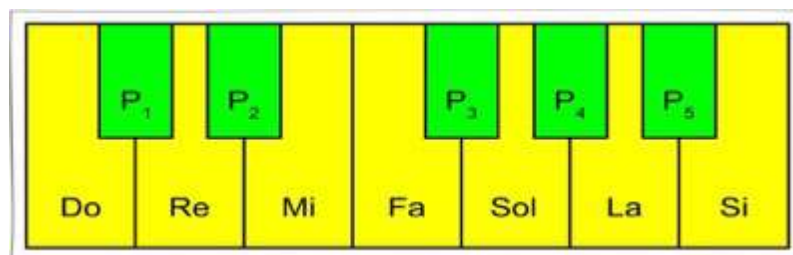

on the "Maxim's table"- it is a grating from octave 12 to octave 256 of all possible structure connections for all types of fields and their interactions. A total of 1064 elements can be obtained from the Maxim table, which differ by at least one feature.

I will not give the calculation of frequencies here, and I will not dwell on the detailed perception of sound (and pronunciation), since the next chapter will be devoted to the music of speech, as well as phonetics (Morozov's square). Taking into account the presence of genetic tables, as well as the musical series of the "Maxim's table", I was able **to compose "my own" symphonies of the human body**, to examine the actions of individual factors on the human body. But that is not all. The musical series of the "Maxim's table" **ALLOWS MAKING TESTS** by the coordinates of mineral deposits, **to search for deposits by resonance**. The following table shows the baseline frequency of chemical elements at an absolute vacuum temperature of **3,6°K**. As the temperature rises, the frequency parameters shift upwards, and the parameters of the basic bonds in an atom change.

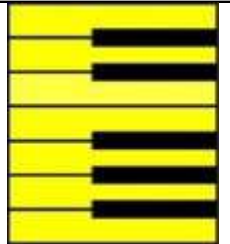
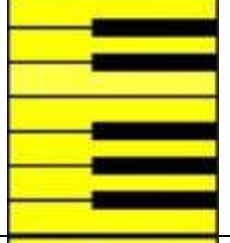
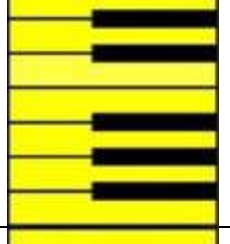
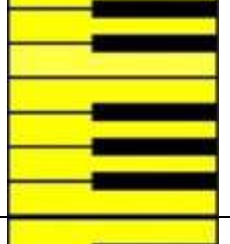
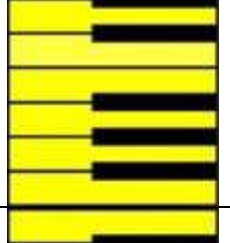
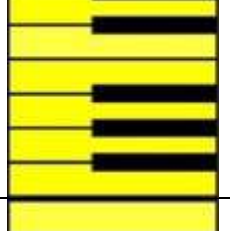

The symbols in the drawing are introduced in the table. In the future, we will adhere to these symbols, all the rest corresponds to musical literacy.

Octave (table)	The initial index	German	French	German	French		
		27,5 30,6725		H ₂ A ₂ B ₂	la ₋₁ si ₋₁	Sub	
5	32	33 37,125 41,25 44 49,5 55 61,875	32 36 40 42 48 53 60	C ₁ D ₁ E ₁ F ₁ G ₁ A ₁ H ₁	Do Re Mi Fa Sol La si	Contr-octave	

6	64	66 74,25 82,5 88 99 110 123,75	64 72 80 85 96 106 120	C D E F G A H	do ₁ re ₁ mi ₁ fa ₁ sol ₁ la ₁ si ₁	Large octave	
7	128	132 148,5 165 176 198 220 247,143	128 144 160 171 192 213 240	c d e f g a h	do ₂ re ₂ mi ₂ fa ₂ sol ₂ la ₂ si ₂	little octave	
8	256	264 297 330 352 396 440 495	256 288 320 341 384 427 480	c ^I d ^I e ^I f ^I g ^I a ^I h ^I	do ₃ re ₃ mi ₃ fa ₃ sol ₃ la ₃ si ₃	Octave 1	
9	512	528 594 660 704 792 880 990	512 576 640 683 763 853 960	c ^{II} d ^{II} e ^{II} f ^{II} g ^{II} a ^{II} h ^{II}	do ₄ re ₄ mi ₄ fa ₄ sol ₄ la ₄ si ₄	Octave 2	
10	1024	1056 1188 1320 1408 1584 1760 1980	1024 1152 1280 1385 1536 1707 1920	c ^{III} d ^{III} e ^{III} f ^{III} g ^{III} a ^{III} h ^{III}	do ₅ re ₅ mi ₅ fa ₅ sol ₅ la ₅ si ₅	octave 3	
11	2048	2112 2376 2640 2816 3168 3520 3960	2048 2304 2560 2731 3072 3413 3840	c ^{IV} d ^{IV} e ^{IV} f ^{IV} g ^{IV} a ^{IV} h ^{IV}	do ₆ re ₆ mi ₆ fa ₆ sol ₆ la ₆ si ₆	octave 4	
12	4096	4224	4096	c ^V	do ₇	Октава 5	

Each octave has 7 tones and 5 semitones; as a result we get a great number of combinations of the vibration series. When forming the musical series of the chemical elements table, we will adhere to the French symbols.

The following table is the musical series of chemical elements for the element decay temperature (*see Appendix 1 to Chapter 7*). I gave **ALL AUTHENTIC TABLES**, compiled *by A. Khatybov as the "Maxim" Tables*, in the Appendix to this chapter, so that it was more

convenient for the readers. Those who get interested in it will figure them out in detail. Those who have difficulty in perception should not be upset. Your Brain will determine what to take from this material. Feel free to go forward, do not stop at anything.

The musical series adopted in music **does not correspond to the real musical series**, therefore, we will clarify the musical series of chemical elements. **We introduce a new note Na** and three additional semitones – P6, P7, P8.

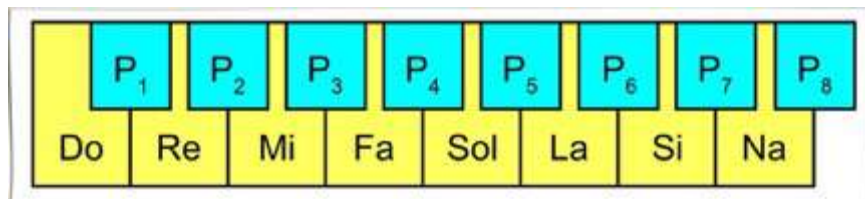

Octave, 8 tones and 8 semitones

Let us consider the musical series of the new construction. This series, of course, differs from the generally accepted, but make it possible to accurately link specific values to the notes, while there will be a slight shift of the tuning fork. Now we make a table of the series, for example for octave 10:

Nº	Tone	Semitone	Quarter note	Value	Nº	Tone	Semitone	Quarter note	Value
1	Do			1024	17	Sol			1536
2			Do+P ₁	1056	18			Sol+P ₅	1568
3		P ₁		1088	19		P ₅		1600
4			Re+P ₁	1120	20			La+P ₆	1632
5	Re			1152	21	La			1664
6			Re+P ₂	1184	22			La+P ₆	1760
7		P ₂		1216	23		P ₆		1728
8			Mi+P ₂	1248	24			Si+P ₆	1760
9	Mi			1280	25	Si			1792
10			Mi+P ₃	1312	26			Si+P ₇	1824
11		P ₃		1344	27		P ₇		1856
12			Fa+P ₃	1376	28			Na+P ₇	1888
13	Fa			1408	29	Na			1920
14			Fa+P ₄	1440	30			Na+P ₈	1952
15		P ₄		1472	31		P ₈		1984
16			Sol+P ₄	1504	32			Do+P ₈	2016

In the table, the last line (**DO**) refers to octave **11**. The octave is divided into 64 parts. Calculation of any tone (T) within one octave: $2^{N+T} \cdot 2^{N-3}$ (**T=0, 1, 2, 3, 4, 5, 6, 7**).

Calculation of the first semitone within one octave (P): $2^{N+T} \cdot 2^{N-4}$. The rest – in steps of 2^{N-3} . Calculation of any first quarter within one octave: $2N$

+ $2N - 5$. The rest – in steps of $2N - 3$. Calculation of any second quarter within one octave: $2^N + 2^{N-4} + 2^{N-5}$. The rest – in steps of 2^{N-3} . The table is given in **Appendix 2**.

7.9. Chemistry of the "Invisible"

Unlike modern structure, we are dealing with quite a new one, which does not fit into the canons, known for more than 100 years. Nevertheless, we have to carry out any operations with atoms, using the invisible atoms groups, considering that the minimum group of atoms consists of four atoms that are interconnected and form a tetrahedron with equal sides. The groups are located on the main diagonal, their numbering is given earlier. Our goal is to make a table of atomic structures, proceeding from the peculiarities of their arrangement on the main diagonal. (**Appendix 3 – “The Maxim Table”, or the table of nuclear reactors considering “the invisible atoms”**).

Unfortunately, there are no other chemical elements in ours and "the invisible" system. Chemical elements were obtained, including "the invisible" elements. Possible options for combining these elements into a "nuclear reactor" are listed below. Any attempt to find a new element will not succeed. In the last resort, there will be confirmation of the existence of chemical elements from the "Maxim table". The following table explains this fact.

No	Chemical element from the Mendeleev table	Number of atoms	Notes	Stability
99	Es	319	Isoster U	Unstable
100	Fm	320	Isoster U	Stabile
101	Md	321	Isoster U	Unstable
102	No	322	Isoster U	Stabile
103	Lr	323	Isoster U	Unstable
104	Ns	324	Isoster U	Stabile
105	Ku	325	Isoster U	Unstable
106		326	Isoster U	Stabile
107		327	Isoster U	Unstable

Pay attention to the fact that we changed places the "chemical elements" from the periodic table with numbers **104, 105** according to the Maxim table.

Explanations to the "Maxim's table"⁸³

5. In the atom group (1) any element from the Maxim table can be located according to the conformity table.
6. In the atom group (2) the elements specified in the conformity table are located.
7. In group (3) the antiatoms of the atom group (1) are located.
8. In group (4) anti-atoms of the atom group (2) are located.

As the frequencies change, STABLE AUTO-VIBRATING CIRCUITS are formed, which are commonly called "chemical elements". Combinations of these elements make the diversity of the world.

Strictly definite combinations of compounds in line with the laws of the form made a man, but this is exactly in conformity with all the peculiarities of our solar system. In other systems, other formations are possible, including "nuclear reactors" different from ours. It is also possible the existence of materials and propulsion systems for movement in a vacuum. This aspect is considered in more detail in the works of A. Khatybov, which are not yet public. And do not blame me for the fact that I do not want to publish this great amount of information and make it accessible to everyone. Unfortunately, the publicity of such material is used to the detriment of people, rather than to the good. Everything has its time. What I publish here is more than enough. Take me for my word – I know what I'm talking about.

So that not to "turn over" the world immediately, the binding of chemical elements to the periodic table is carried out, but this does not mean that the periodic table itself does not require any improvements, therefore a new table has been compiled, which is called the **MAXIM NUCLEAR REACTORS** table, which is given in **Appendix 3**. In contrast to the periodic table, the new table makes it possible to see the formation of elements, the connection of elements into certain forms, and also directly from the table of the musical series of chemical elements to calculate the parameters of the chemical element in compounds with other structures. All this is called "cold nuclear synthesis", since the change in the compounds parameters is not always connected with high temperatures. All this is reflected in **Appendix 4** (Formation of chemical elements).

⁸³ I recommend you to return to chapter 6 of this book (6.3. The structure of "spare parts" – chemical elements).

Now let us consider the nuclear reactors included in atom group (1)

Nº	Element	Isosters	Out of them – for formation of man
1	H	4, 6, 8	4, 6, 8
2	He	8, 10, 12	8, 10, 12
3	Li	12, 14, 16	-
4	Be	16, 18, 20, 22, 24, 26, 28, 30, 32	16, 18, 20, 22, 24, 26, 28, 30, 32
5	C	25, 27	25, 27
6	N	28, 30, 32	28, 30, 32
7	Ne	40, 42, 44	-
8	Na	44, 46, 48	-
9	Mg	48, 50, 52	50, 52

For connection with the nuclear reactor of "the invisible world" 9 groups of elements are used, **6 of them are for the formation of man**. But I wanted, first of all, to understand which groups form feedbacks. This was important when making Programs for the Generator, which had to be put on the server, and from which the Session could be downloaded. The way **the Health Improving Sessions 1 and 2** of Nicolai Levashov were transferred, I mentioned in the previous books, but in this case it was necessary to create something different. Let us see which groups form feedbacks.

Note that the number of elements in the groups of atoms (1) and (3) is few, it can be seen from the table below, but there are also groups of atoms (2) and (4).

Nº	Element (1)	Isoster	Element (3) «The invisible»	Isoster
1	H	4	H	5,7
2	H	6	H	5
3	H	8	H	7
4	He	8	He	9, 11
5	He	10	He	9
6	He	12	He	11
7	Be	16	Be	17, 19, 21, 23, 25, 27, 29, 31
8	Be	18	Be	17
9	Be	20	Be	19
10	Be	22	Be	21
11	C	25	C	24, 26, 28
12	C	27	C	26, 28
13	N	28	N	29, 31
14	N	30	N	29
15	N	32	N	31
16	Mg	50	Mg	59, 51

17	Mg	52	Mg	51
----	----	----	----	----

The following table below, is for the atoms group (3) depending on the presence of a particular chemical element in the atoms group (1). The last column in the table – the number of options for the atoms group (2) – "Mirror".

Nº	(1)	(3)	Number of options
1			2
2			1
3		Be17, Be19, Be21, Be23, Be22, Na41, Mg49, S65, Cl69, Ca82, Ca83, Ca104	1
4	He8	Be16, Be18, Be20, Be22, C25, C27, Mg50, Mg52, Al53, P61, S65, Cl69, Ca82, Ca83, Ca104	1
5	He10	Be16, Be18, Be20, Be22, C25, C27, Mg50, Mg52, Al53, Al55, P61, Ca80, Ca84	1
6	He12	Be17, Be19, C25, C27, Mg49, Al53, P61, Ca80, Ca84	1
7	Be16	H4, H6, H8, He8, He10, He12, Be17, Be19, Be21, Be23, N28, N30, N32, Mg50, Mg52	8
8	Be18	H4, H6, H8, He8, He10, He12, Be17, Be19, Be21, Be23, N28, N30, N32, Mg50, Mg52	1
9	Be20	H4, H6, H8, He8, He10, He12, Be17, Be19, Be21, Be23, N28, N30, N32, Mg50, Mg52	1
10	Be22	H4, H6, H8, He8, He10, He12, Be17, Be19, Be21, Be23, N28, N30, N32, Mg50, Mg52	1
11	C25	H4, H6, H8, He8, He10, He12, N28, N30, N32	3
12	C27	H4, H6, H8, He8, He10, He12, N28, N30, N32	2
13	N28	Be17, Be21, C25, C27, Mg50, Mg52	2
14	N30	Be17, Be21, C25, C27, Mg50, Mg52	1
15	N32	Be17, Be21, C25, C27, Mg50, Mg52	1
16	Mg50	H4, H6, H8, He8, He10, He12, N28, N30, N32	2
17	Mg52	H4, H6, H8, He8, He10, He12, N28, N30, N32	1

As can be seen from the table, there are **386** variants of atomic reactors. Considering the atoms group (4) it is possible for a man to have C_{386}^{64} atomic reactors, which is quite inconceivable in terms of their number.

Since **EVERY MAN IS INDIVIDUAL**, different in race, civilization, many other characteristics, such a number of atomic reactors for the formation of a man, is quite acceptable taking into account the symmetry of our space. As an example, we consider the table of ***the number of atomic reactors by race, civilization, and separately by a genetically degenerating structure.***

Nº	Type	The variant of atomic reactors
----	------	--------------------------------

1	civilization 7	$C_{22,1}^{32}$
2	civilization 6	$C_{19,4}^{29}$
3	civilization 5	$C_{18,5}^{27}$
4	civilization 4	$C_{17,6}^{27}$
5	civilization 3	$C_{16,4}^{26}$
6	civilization 2	$C_{15,2}^{25}$
7	civilization 1	$C_{15,6}^{24}$
8	civilization 0	$C_{14,4}^{23}$
9	White race	$C_{18,6}^{28}$
10	Black race	$C_{18,2}^{26}$
11	Yellow race	$C_{17,4}^{25}$
12	Red race	$C_{16,8}^{24}$
13	Genetically degenerates	$C_{13,8}^{22}$

It is interesting to note that in the latter case (13) the number of combinations coincides with the number of letters of the alphabet used. It can also be noted here that civilization 7 is ***the color of the White race***.

Here is a vacuum grating, for better understanding.

No	Name	Octave, tone
1	Neutron	58 re
2	Neutrino	58 mi
3	Antineutrino (in antiphase)	58 mi
4	Connection with «The Invisible» – groups (1) and (3)	61
5	Connection of atoms groups (1) and (2)	58

And, of course, ***an atom musical series***, which, in fact, we are interested in regarding the created Session.

No	Name	Octave, tone
1	Neutrino, neutrino surface	54 re
2	Neutron, neutron surface	57
3	Between neutrino and neutron surfaces	57 P ₂
4	Proton, proton surface	61
5	Between proton and neutron surfaces	58 fa
6	Electron, electron surface, electric field	64
7	Between electron and proton surfaces	60
8	Gravitation surface 1 Gravitation field	67
9	Between gravitation surface 1 and electron surface Magnetic field	62
10	Gravitation surfaces 2, 3, 4, 5, 6, 7	68
11	Between gravitation surfaces 1 and 2	67 mi
12	Between gravitation surfaces 2 and 3	67 fa
13	Between gravitation surfaces 3 and 4	67 sol
14	Between gravitation surfaces 4 and 5	67 la
15	Between gravitation surfaces 5 and 6	67 si
16	Between gravitation surfaces 6 and 7	68 re

17	An atom center	72
18	Between an atom center and gravitation surface 7	70

And also "the temperature series".

No	Initial octave	Transition Octave	Delta	LnT	No	Initial Octave	Transition octave	Delta	LnT
1	31	32	25	1	25	55	56	3	303
2	32	33	24	25	26	56	57	6	309
3	33	34	23	48	27	57	58	9	318
4	34	35	22	70	28	58	59	12	330
5	35	36	21	91	29	59	60	15	355
6	36	37	20	111	30	60	61	18	373
7	37	38	19	130	31	61	62	21	394
8	38	39	18	148	32	62	63	24	418
9	39	40	17	165	33	63	64	27	445
10	40	41	16	181	34	64	65	30	475
11	41	42	15	196	35	65	66	33	508
12	42	43	141	210	36	66	67	36	544
13	43	44	13	223	37	67	68	39	583
14	44	45	12	225	38	68	69	42	625
15	45	46	11	246	39	69	70	45	670
16	46	47	10	256	40	70	71	48	718
17	47	48	9	265	41	71	72	51	769
18	48	49	8	273	42	72	73	54	813
19	49	50	7	280	43	73	74	57	870
20	50	51	6	286	44	74	75	60	930
21	51	52	5	291	45	75	76	63	993
22	52	53	4	295	46	76	77	66	1059
23	53	54	3	298	47	77	78	69	1128
24	54	55	2	300	48	78	79	72	1200

The work with the table of "temperature"

I want to emphasize once again that there is a strong dependence between the octaves. It is necessary to select a specific chemical element (or any other connection). The table shows the data for the octaves (with the destruction of the connection, which coincides in the musical series with the octave). Instructions for working with the "temperature" table and other tables marked here are given in the calculation part of **A. Khatybov**, which today, for reasons already clear to the reader, are not public. Inability, and especially misunderstanding? – can bring about some harm. Because in the

brain like a rusty wheel on a rusty axis and in rusty bearings with a painful screech turns the thought: "...if I could think of something and apply it so that everything would remain the same? "

7.10. Pure frequency

It is clear that music should be considered much broader than just sound; it should be listened to and used wisely. Music, in which sounds, rhythm and musical pattern are subordinated to the laws of harmony, has a beneficial effect on human health and development: it harmonizes the world of feelings, heals the body, fills with energy, strength; gives food to the soul – spiritual impressions; affects the intellect and the brain, improving memory and speeding up the learning process; prolongs life, if, of course, it is the music which I tried to tell you about. And an important step towards this is the awareness of what kind of music we listen to and what impact it has on our body. Nicolai Levashov also noted that the same music affected people with different evolutionary levels in different ways. Music can be considered as **ONE OF THE INSTRUMENTS** of influence on the human consciousness and, therefore, a kind of psi-weapon. A person listening to music, not only hears it – his Spirit (Brain) is being rebuilt under the influence of the rhythm and frequency of sounds⁸⁴. Music, as if, imposes upon the Spirit of man a certain qualitative state, which may be in harmony with his own or completely incompatible. In this case, the reaction takes place on a subconscious level and is practically not controlled by the consciousness. The maximum influence of the sounds of music falls on the astral body – it affects the development of Human personality. Nikolai Levashov and Sergey Danilov noted that the development of the physical body provided for the evolution of the etheric, astral and mental bodies, because it has the property of transforming the forms of matter and for their catching it has peculiar **antennas – seven chakras**⁸⁵, **that is, energy centers**. As long as there is a harmony of flows **will** (orange sexual chakra forming the etheric body), **heart** (yellow chakra of the solar plexus forming

⁸⁴ By the way, sounds with a few number of vibrations (up to 300 Hz) are called low-frequency sounds, with a number of vibrations more than 3000 Hz – high-frequency ones, with a frequency of vibrations from 300 to 3000 Hz – sounds of medium frequency.

⁸⁵ The chakra in the spiritual practices of Hinduism is a psycho-energetic center in the human subtle body, which is the intersection of the channels through which vital energy flows, as well as the object for concentration in the practices of tantra and yoga.

the astral body) and **mind** (green heart chakra forming the mental body), in other words, harmony between the etheric, astral and first mental bodies – it is impossible to control a man. These three qualitative flows of matter, whose balance is the golden section, provide conditions for the harmonious development of a personality. It is enough to cover one of them – and the harmony of the flows is broken. Such a man can be easily influenced. The task of the control is to block one of the three flows. Here is one of the examples of the low-frequency musical influence on the orange sexual chakra – modern pop music, which uses an extremely simple and often computer-synthesized rhythm based on digital technology.

N. Levashov **FOCUSED SPECIAL ATTENTION** to the frequency of repetition of low sounds, the so-called rhythm. Rhythm, being the heart of music, has the strongest effect on the body and emotions of man. Hard computer rhythms are harmful to man, this has already been proven. No living man can keep the rhythm of music with much precision. But a computer can. Having slipped into the younger generation as bait music of this type, from which makes the latter get stoned, you can very easily and reliably destroy the evolutionary future of the young. This is actually happening in reality through the use of certain types of "music" especially "rap", rock and "heavy metal". Rock concert – 120 db – the volume of which is called the pain threshold. With long exposure to such a sound, there is an irreversible deterioration of hearing: a person accustomed to rock concerts will never hear a low whisper or the rustle of leaves – 20 db. Normal speech – 60 db. This uncomplicated "popular music", "pop", its primitive harmonies primitively use our Brain without developing it. Hard computer rhythms make a person dull, drives him into one of the stable, passive mental states. The etheric body cannot fully develop. A person becomes weak, weak-willed, and easily controlled. **Sound waves with a frequency of 6-8 Hz are generally weapons.** This can be easily understood from the tables presented in the appendix to the chapter. The sound waves with a given frequency cause such a redistribution of primary matter in the zones of activity, which brings about irreversible processes in highly organized cells, the Brain neurons. As a result of this, **THERE HAPPENS THE BRAIN OVERLOADING**, neurons are destroyed, the Brain control is disturbed, and a person dies... When listening to complex, rich music (of higher-frequency – classical, folk ethnic, especially Russian folk music), many different Brain regions are involved. The Brain "trains", the synoptic connections between different, even very distant parts of the Brain are strengthened. The centers for processing semantic information, emotional

and many other areas are also involved. Roughly speaking, "complex music" that we enjoy (which is also important) makes our Brain "more talented". This is especially important for children under seven years old, when the Brain is formed. Why am I writing about this? Because everything had to be taken into account in the development of *the Session, and Beethoven's Moonlight Sonata* reasonably fell into its structure. No generation against the background, for example, of rock music or some popular hit, which suddenly hit the hits today and is forgotten tomorrow, could not be applied to it. It is not difficult to understand why on our television and radio we **CAN HEAR SO FEW** Russian folk songs, ethnic songs of different nations, distinguished by original harmony, vocabulary, virtuoso solo and a-capella with its incredibly beautiful four-voices, with free variations and moving second parts. Today, church chants are trying to occupy a niche between folk and classical music, whose level of influence on a person is much higher than that of classical, symphonic music, but lower than folk ethnic one, and especially Russian folk song. I hope readers understand why.

As we have already discussed, today *the 440 Hz frequency, the note of La of the first octave*, serves as a standard for tuning musical instruments, from which the rest of the scale is built. In accordance with the diversions on the deviation **from the scale of 432 Hz**.

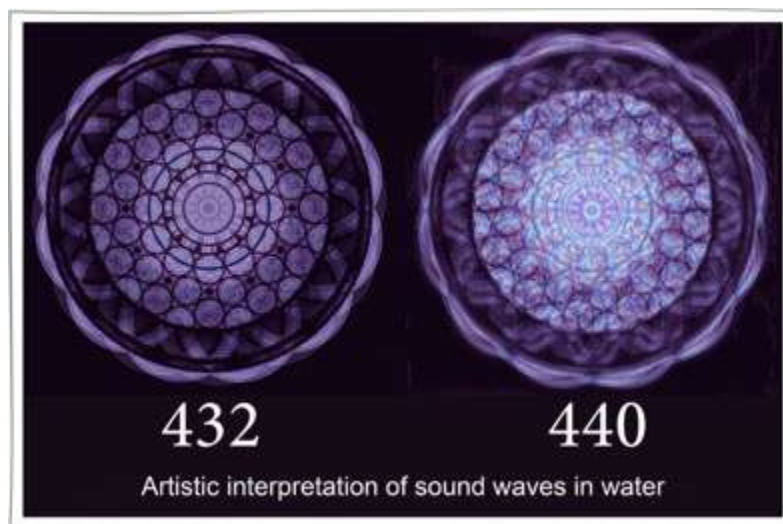

Let me remind you that diversions on deviation from **432 Hz** were undertaken during the world wars, that is, at the moment of changing the stages of civilization development with the introduction of certain Brain genotypes. If you count the digital root of **435, 440 and 432**, then in the first case it is **12**, then – **8**. But initially it was **9**, frequency 432 Hz. And, of interest is the fact, that when tuning to the frequency multiple of nine, note **DO** was equal to 512 Hz, that is, 29, and thus was harmonized with all the elements of our first-order superspace according to the Golden Section rule.

As we know, when creating the Earth, **8,640,000** meridians were laid (in science they are called magnetic meridians, though not 360, but somewhat more), at the depth of about 1000 meters. These are energy cords. (In a day there should be exactly 86400 seconds = 24·60·60), that is, exactly 100 tires fall on 1 daily second. The number **864** is twice **432**; respectively, both digital roots are equal to **9**, which means they are synchronized. It turns out that through the law of the nine, it is the law of the octave and the particular manifestation of the laws of the golden section, the reference frequency of 432 Hz **BRINGS ABOUT AIR RESONANCE AND HARMONY** with the cosmic processes of our universe. And any deviations, respectively, *lead the listener out of the resonance with the universe.*

Everything that happens in nature is related to the changes in matters, their composition, quantity, and one or another dynamics of their evolution. You remember that our Metauniverse forms a system of discrete spaces of different qualitative and quantitative composition. Our space-universe is formed *by the merging of seven forms of matter and is located at a certain offset from the zone center of the dimension curvature* in which our Metauniverse was born. In the center of this zone, a space-universe of nine forms of matter was formed, and, successively moving away from the center, in discrete zones of the dimensionality change at $\Delta\lambda$, space-universes of eight, seven, six, five, four, three, two forms of matter of our type of dimensionality quantization were formed. This is substantiated in the works of Levashov, applied by him in the creation of the Generator and used to create **the "SvetL" Programs**. And if on a global scale we consider the Metauniverse evolution, we can come to the conclusion that the central zone of nine forms of matter is the most stable, while the border line zones are unstable and external influences at the border of space – universes created by the merging of two forms of matter cause instability. And for all that, there arises evolutionary development of certain processes in the matter forming these spaces-universes. And this is the most important conclusion in the matter that was decided to implement.

Our metauniverse is formed by nine forms of matter. The number of combinations of them is equal to **459**. Taking into account that the minimum number of interacting forms of matter should be at least two, this figure can be obtained from the formula

$$\Sigma \cdot C_n^m = \frac{n!}{m!(m-n)}$$

where: $n=9$; $2 \leq m \leq 9$.

We, or rather our Brain, in its functional complex processes is a simplified "technological" similarity to our galaxy, which we are to learn, open its secrets and master it. What kind of "choir" are typical basic connections of our Brain neurons? This is not yet known to us, but it is extremely important to know, at least in order to understand in what way and which direction of perfection it is possible for a Man to raise the levels of his Brain octaves and in what cases man's initiative is possible without causing him harm, that is, without destroying the current patterns of natural neurons connections. And as one of the "instruments" of this are sounds and music in the whole range of the possible. This conclusion is an extremely important step on the way of the civilized, not violent re-creation of Man and gaining his Mind perfection, but in terms of importance in the cognitive plan – this is precisely the barrier threshold of knowledge, having crossed over which its **QUALITY RISES A STEP ABOVE**, – that is one should strive for. We assume that the former limited materialistic view of the unknown mysteries of our Brain potentialities through superficial knowledge is a thing of the past, but we will pay tribute to it, because this view was a platform for those who have chosen the path of knowledge and is moving to the near future.

7.11. Subject- object conception

I take leave to remark on the sounds that appeared 5-7 years ago, and are not related to any musical instruments but being heard by some people as languid-guttural sounds from the bosom of the Earth. They are directly related to the local processes of geographic correction of the complex controlling gravitational state and the magnetic field in this region, and also directly related to regionally ongoing processes in the realm of people in this area, each in their own way "sound tracking" these special actions (as B. Makov says, even disregarding the opinions of deputies at various levels – whether in Eastern Europe or in the Middle East, etc.). And this is what is happening and will go on happening all over our planet this period. People should not fear of this, especially those who have carefully read this chapter. And someone's interference and their fascinating "stories" about the apocalypse and other troubles for humanity do not play any role in these processes, since no one knows where to interfere with, and in general there is no place to interfere!

May those cognizing the truth forgive me for such a simplified analogy, but it is the analogy, that is closer to the true level in understanding and subject-object conception in this most complex and not yet completely intelligible question for us, in which the most serious ongoing changes, and especially in the life support system of people, which are accompanied and presented by a complex of their own "melodic sound" in the processes of energy-information controlling support of our being, and especially the process of gravity control support strictly identified for each galaxy separately. In recent years, especially **since April 2011, SUCH PROCESSES OF CHANGES of the "musical repertoire" have been manifesting themselves on the Earth.**

When it became clear to me, there was a desire to somehow help people who just started to lose their orientation in life (which basically resulted in a massive mental disorder and, brought about diseases of various kinds, since the Brain, due to its limited development (depending on the genotype), began to lose control of the flesh cells. This prompted me the creation of the Session that could somehow alleviate the resultant effect. The result exceeded all my expectations and is expressed in gratitude of the people who began to use it. However, we continue our reflections.

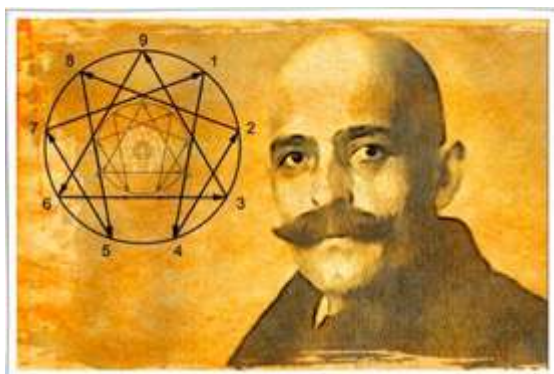

A contemporary of Nikola Tesla was the last black magician (according to N. V. Levashov) from the Byzantine dynasty of Palaeologus, **G. I. Gurdjieff**. He advanced the theory of the Law of Octaves, postulating a 9-step cycle of full development, according to a 7-note series

and two intervals. ***This system executive revealed the imperfection of the interventionist system.*** According to Gurdjieff, the Law of Octaves binds all processes in the Universe. The one who knows the scale of transitions and the laws of octaves, this makes it possible to accurately know the core of any phenomenon and in relations with all objects and phenomena related to it. In his Law of Octaves, he kept silent (or did not know) about the real state of



things, postulating a double transition interval of the development cycle.

However, everything that Gurdjieff did was ***within the framework of the interventionist ECS*** in contrast to ***N. Tesla*** who was "allowed" to think beyond the limits of this ECS. The characteristic fact is that A. Khatybov relied in his calculations regarding the "atom musical accompaniment" precisely on the calculations of N. Tesla, which only a few can realize even in our time.

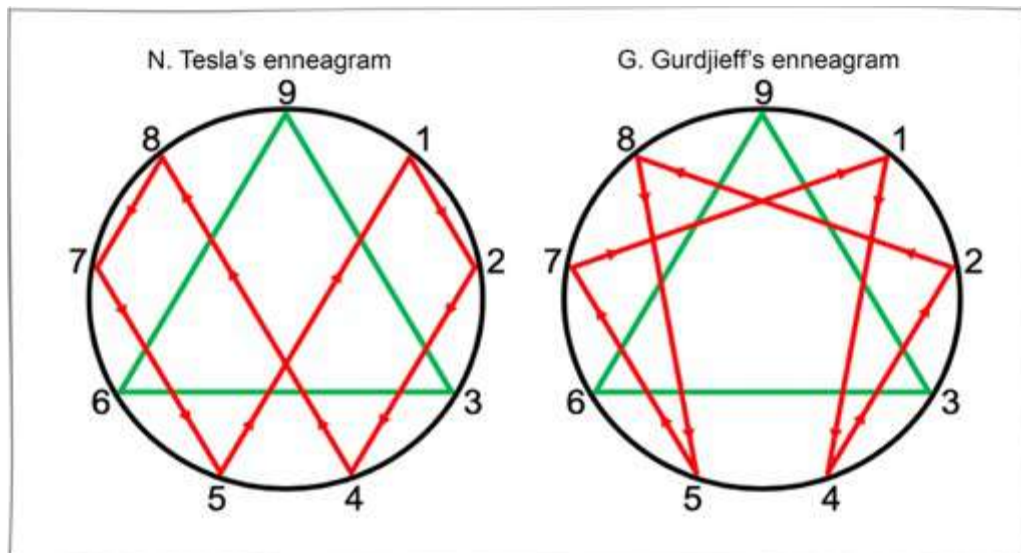

Let me remind you that there exist the Supersystem, System and Subsystem.

Tasks of the Supersystem:

- control of the clock of time;
- Programs transmission to the System for implementation.

Tasks of the System:

- to ensure the Programs execution;
- to make permanent control over the Program execution.

Tasks of the Subsystem:

- fulfill all the requirements of the Program;
- respond correctly to all changes occurring during the execution of the Program.

The Supersystem and the System have one-way communication:
Supersystem → System.

The System ⇔ The Subsystem – a two-way communication, herewith:
 all the Programmed functions are unilaterally formed and recorded by the

System, translating for the Subsystem in the form created by the Program. **In the Enneagram⁸⁶**, <System> is the green triangle "3-6-9." <System> is the Earth Control System (ECS).

NECS is Native ECS in Nikola Tesla's enneagram; the IECS is an interventionist Earth Control System in G.I. Gurdjieff's enneagram.

The <Subsystem> is the red broken line of the hexagon, represents the **MOVEMENT of the INFORMATION CHARGE** in the Möbius sphere.

"To transmit information, <the System> **USES THE MUSICAL SERIES**, and the resonant contours of the spine of the <Subsystem> are the information receivers".

Communication is carried out through a musical series, using musical notation.

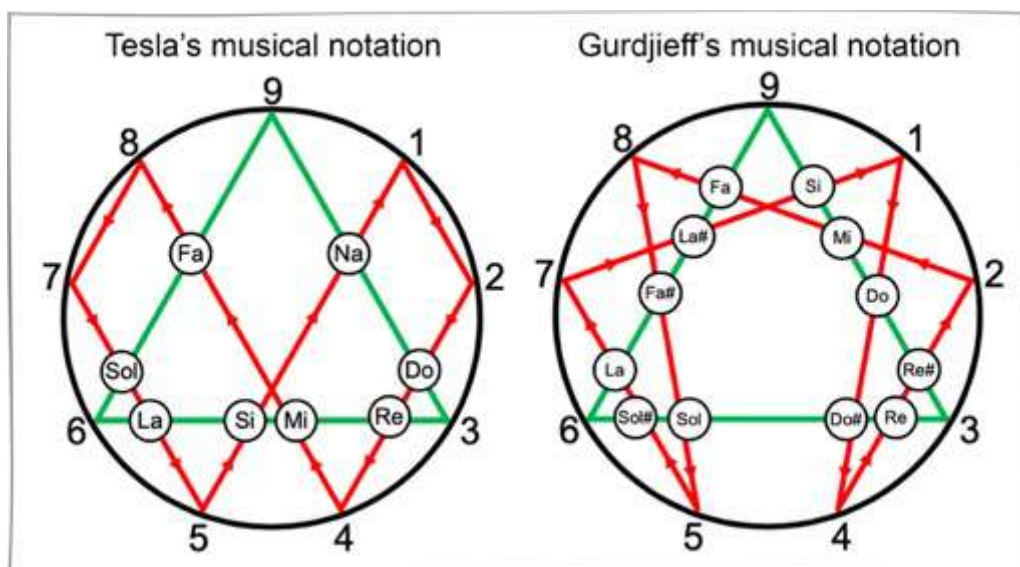

As we already know, **the Russian music series** is 8-note (DO, RE, MI, FA, SOL, LA, SI, NA), it has been returned and has been used since 2007. This series allows encoding any information in the 64-character alphabet. In N. Tesla's enneagram, there are 8 points of contact between the green and red lines, which correspond to the 8-note Russian musical series. This series allows **CODING AND DECODING ANY INFORMATION** coming from the Native Earth Control System (NECS). In the Gurdjieff enneagram, a hexagon crosses a triangle 12 times, which corresponds to **the old musical notation of 12 semitones and corresponds to a musical series of 7 notes with the addition of 5 semitones (DO, DO**

⁸⁶ Enneagram – from the Greek. ennea is nine and gramma is the outline, the figure.

#, RE, RE #, MI, FA, FA #, SOL, SOL #, LA, LA #, SI). The interventionist control system in the enneagram of Gurdjieff note NA "is removed". The meaning of this was to remove the boundaries of the medium of existence (**note NA**) in order to have **DIRECT ACCESS TO THE OBJECT OF MANIPULATION** and to conduct experiments on "cultivation" of the Brain genotypes. For all that, instead of a structured (harmonious) medium, there arose an amorphous medium (marsh), which actually extinguished "emerging disturbances" from people exposed to these experiments.

This is also confirmed by the *"reflections" of Elena Arkhipova*, who did this in the framework of the musical image of the process (shown above), and *Andrei Rekhtin's* judgment that the true law of development by octave consists of 9 notes, similar to 9 colors of the visible spectrum of electromagnetic radiation. Or rather, *of 8 notes and the ninth transition interval NoNa*. This will be especially clear to people who have musical education and to those who taught at school notes and their image on paper.

Music (mostly classical and folk) has the strongest health effects on various organs of man and his psychological state. All kinds of music activate that part of the cerebral cortex, which perceives air vibrations caused by certain sound waves. The healing effect of music is due to the fact, among other factors, that there are a lot of high-frequency sounds in it. The abundance of **EXACTLY HIGH FREQUENCIES** in musical works carries the most powerful energy charge not only for the brain, but also for the whole organism. Even in ancient times it was known, or more precisely, at that time few people who lived in the "so-called deep antiquity" received information from "before the invasion" period that sound vibrations (and, in particular, music) provide an effective therapeutic (health) effect on the human body and psyche. Pythagoras, who, among other flattering titles, is called the "first music therapist", created a whole chain of such therapy and successfully applied it. And in the Parthian kingdom (III century BC) a special music and medical center was built, in which with the help of specially selected melodies they were treated for *depression, nervous breakdowns and pains in the heart*. So they thought – those who treated, and something that controlled it – just solved the task of developing and "growing" specific Brain genotypes, including testing the use of sounds and music when affecting the Brain. That's how it was.

The Brain itself, in my opinion, is a kind of very sophisticated musical instrument or, if you like, even music itself. The idea that the Brain is a kind of supercomputer, so fashionable over the last decades in the creation of artificial intellect, begins to lose ground and fall apart. I began to "watch" the Brain very carefully when I started developing the Programs for the Generator and the generation. I did not understand then – what is music? I discussed this issue with serious musicians, including Mstislav Rostropovich and his wife Galina Vishnevskaya, with whom I was on friendly terms. I had the same question – music, what is it? I didn't mean the score written by notes that lies before you – everything was clear with this, but in general – what is it? And then **note Na** fell like snow on my head. Music is a sound wave, a physical thing that "hits" into the eardrum and through the auditory nerve (I will not describe the mechanism in detail here on the basis of modern biology and medicine) "comes" into the brain and only then becomes what we call music. Before it comes to the Brain it is not music yet. Only there ... it becomes music. It is music when there is a listener (the Brain), **READY TO LISTEN TO IT**. Ready means prepared (genotype). If it sounds for a mosquito, even with suitable ears, it is useless. For a mosquito, physically it is sound. There is great difference between sound and music. The difficulty for me was to make the Session "good" to all people, regardless of their Brain genotype. Another thing is what and how the Brain itself "takes" from this Session and applies it for itself. Therefore, the idea of visualization through the pictures of the working generation was born that we managed to create.

When talking to Rostropovich, I noticed that he had a somewhat strange relationship with time. He could subconsciously slow down or speed up time. He said – "time is like jelly. It can stretch, and can squise. When I go along the orchestra to my place where the cello is, and it takes me 5-10 seconds, in my head the whole piece I am going to perform should be played through . But this does not always happen, and if it does not, then I don't get the performance the way it should be. It is just a mechanical reproduction of notes in the score. Not bad either, but this is not something I would like to convey to the listener". He told me that he sees music in color, as well as some of his listeners who perceive the information carried by music in one modality – acoustic (auditory), and at the same time they not only hear the sound, but also see the color of this sound. This is what was to be achieved while listening to the Session. All this once again confirms the conclusions of N. Levashov and A. Khatybov that there are different degrees of research in science. For example, we, to a certain extent, know how the stomach or the heart works, how ants build an anthill. But, probably, the science of the Brain

can only be compared with the desire to comprehend the construction and the origin of the Universe. Probably today it is impossible to even imagine anything comparable in complexity to the Brain. We do not know today at all what the Brain is, which is supposed to reveal the laws of Nature and why it is necessary to reveal them, if they already work.

7.12. Briefly about the important

In order to see how the created Session interacts with the Brain, to make it simple, let us imagine that the Brain and everything that it controls in man is a vibrating system. And music is also vibration, only orderly, in a certain way, synchronized vibration. It brings order to our system, adjusts it to a certain mode, it affects our mood and the work of internal organs and systems only through the Brain. And any disease manifests itself as quite definite dissonance arising from the **UNBALANCING OF THE SICK ORGAN**, which partially is losing control of the Brain. Music has a very deep and many-sided effect on the Brain by the principle of the acoustic resonance and through it – practically on all functions and processes in human tissues, as well as on emotions, desires and feelings.

The Health Improving Session is based on the principle of the Brain frequency resonance with the music of the Moonlight Sonata by Ludwig van Beethoven, sounding at frequency **432 Hz** and based on the musical series using the eighth **note NA**. The floating "pictures of the generator" (generation in color) complements and deepens the interaction of the entire construction of the Session with the listener's Brain, allowing the Brain to select the resonant components for specific being in disorder (for this or that reason) resonant components of interaction with a certain organ and create a comfortable state of work for the Brain itself. This is manifested in tranquility, restoring sleep, finding spiritual and mental balance. Those, who have already applied this Session told me that music, sound, rhythm and musical pattern are subject to the laws of harmony. It is pleasant to the ear, unique and surprising in its harmony; it has a special healing effect, inspires, and tunes in a positive way, despite the fact that it has some tragic minor notes. The music of the Session, enhanced and "brought" through the Generator, brings the body into a state of inner harmony and evokes a feeling of surprising comfort. A fascinating, unusual, constantly changing picture of the generation itself, an unusually diverse play of rays, spirals under the pulsation of triplet sonata, an unusual range

of colors in accordance with a particular tonal character of assemblies of generation forms,- everyone likes it while contemplating. It was possible to achieve that when listening to and simultaneously watching the Session (which is very important), the Brain is perceiving visual, audio and kinesthetic information.

But this is only a superficial glance at the solution of the problem. And now, I try to substantiate another solution, related to not only the creation of the Session, but also the so-called "software" of everything that was created in the framework of Levashov's Generator and the "SvetL" project as a whole. It was not so difficult to create, having understood with the help of Nicolai and under his guidance and A. Khatybov's calculations, which allowed making corrections to the Programs. It was not difficult on the basis of the calculations shown in this chapter and, especially, in *the Appendix to the chapter*, to create an effective Session with the main current task – making the **SITUATION** in which people found themselves **NOT ON THEIR OWN WILL EASIER**. The world of the past – built by the alien control system on a digital basis with cubic energy structures of the "control" and "executive" elements that directly affect the human brain in order to achieve the goals we know, was destroyed and precisely at that time when everything related to the *project "SvetL"* was giving birth. But the auto-motor-like way of the ongoing events, which were to be realized within the framework of the alien control system, remained in the Brain of people, and different in each, depending on their development within the framework of specific genotypes (sub genotypes, etc. of the Brain). To take everything into account was the main and most difficult task in creating the Session, as it required to solve the problem – "for all and each personally... " I am describing it in detail, being well aware of the fact that it is my information that is interpreted and used in their beneficial way by all those who call themselves "experts of N. Levashov's knowledge", because they have not even an elementary understanding either of the writings of this Man or his Technologies left for us. But envy, far-fetched know-all and personal ambitions here are above all. I do not blame them, knowing what they all end up with.

The world of our future is being built up by the native Control System that uses the Russian language "for communication", *dodecahedral-icosahedra energy constructions* "used" through the old and newly started-up Control Complexes for the people to find harmony between external and internal states in their zones of life support – the space, which has already acquired a new functional-territorial allotment for biological existence in the physical plane. All this had to be considered and, probably,

I would hardly have coped with this task if I did not have the help of those who have repeatedly supported my undertakings, watching my actions (if necessary, just stopping them), those who I have mentioned in the previous books. Of course, these are the Friends of N. Levashov.

Today's world in which we live is "locked" between the old and the new, with **PARTIAL USE OF THE ELEMENTS OF THE PAST**, between those who can no longer (who were selected and "prepared as" special genotypes **4XX** for the realization of the conceived, endowed with the abilities and means) and those who **ARE NOT ABLE YET**, because they have not yet used the provided possibilities. Therefore, it was necessary to create an "instrument" to expand the abilities of the Brain (not for all, of course) on the new foundation created by the returned program, taking into account the expediency of restoring **proto-states**, living conditions and life support as part of restoring the Earth's native Control System, changing the shape of the dispersion space of the true basic radiation frequencies and the translation of human consciousness (specifically, each of the known genotypes and their sub-genotypes) to a different outlook, which is going too difficult in the frame of our understanding of the ongoing. So far there is some choice. Who does not want (more so, can interfere with) – it's better turn to the left; those who agree to use it – turn to the right "and both sides are parted". **AND FOREVER**. Only those who "agreed" will have to, with their own "legs", go from the imposed Brain octaves no higher than 63, altered flesh with the "blocked" fourth codon of DNA and other "innovations" that ensured ever guilty state of mind – to new higher states of the Brain octaves. It was precisely this that was necessary to provide to people, at least, as partial help, who were confronted with the ongoing, which no one could change. That's why I don't give a damn – (sorry for such a comparison) to all the attacks of "experts of Levashov's knowledge", and other spiteful critics and "Internet bastard masters" who try to disprove, without choosing words or even knowing what they are writing about – what works today for the good and has been proven by the effectiveness of the use for already thousands of people. So all of them are to go to the left and... "it is high time". They do not understand one thing (even after reading Levashov and doing something on the basis of "Levashov's knowledge) – in order for them to exist today, just as other people, they need to breathe, drink, eat and save the body from toxins in time. They, like many people today, unfortunately, are looking for the goal and means of its achievement, where in the first place is "**Me**". That's how they live. But in order to live as Man (as N. Levashov used to say and write), **one must live in the name of "WE"**.

But there is a heap of needs, the boundaries of which go beyond the horizon of the worldview, therefore they are not visible at arm's length — yesterday you could walk to them, today you already have to run.

As you already know, the framework of the future construction, that is being formed today are the **FOUR ZONES OF LIVE SUPPORT started in 2012.10.25** by changing the set of base radiation frequencies in them in absolute harmony with the event driven time and Vector range correction of phenomena, actions and events. All this directly affects and is reflected in our Brain with all the ensuing consequences, which mainly manifest themselves in diseases, anxiety, uncertainty and the so-called "rebellious consciousness". But the people who "tried" and applied the Session, much easier stand what is happening and are able to adequately assess their condition. Moreover, such unpleasant things as *arrhythmia*, for example, or *heart problems*, arising from many factors, including changes in the life-support system, just stop upon repeated use of the Session. As for insomnia which torments many people today, this is simply an indispensable tool that begins to work literally from the first-second time. The Session itself, if we consider it **AS AN INSTRUMENT TO HELP** acquire a new, more complex harmony with the changing Life Support System of man and his own changing Mind, has a beneficial effect on his health, fills with energy, strength, affects the intellect, improves memory and accelerates the process of cognition. Experience has shown that the effectiveness of the session increases significantly if the User is the owner of *the "SvetL" Complex* in any of its versions (complex, pendant, and bracelet). This is brought about by a more punctual auto-tuning of the Brain to the frequency resonance. **ONE COMPLETES THE OTHER** to achieve the required goal. In addition, I would like to say about the "production" of a personal "liquid pill" in the framework of the interaction of the Brain, Session and water, and, of course, in relation of the interaction of the Complex, Session, Brain and water – to "replenish" the Brain. Through the correction of the energy-information state of water, certain programmed changes are laid, which are necessary for the Brain in the process of its work regarding the restoration of the lost (for one reason or another) connections in the interaction of the controlled body cells and, through this, improving and healing specific organs. The energy-information state of water thus obtained, both from its interaction directly with the Session and the **"SvetL" Complexes**, positively affects all this. This is what I call the creation of a personal liquid pill. However, the emphasis here should be placed on the specific Brain genotypes, which we now have or, more precisely, what we were made of.

This is possible because, as you remember, there is tritium in water in all its energy states varieties. I'd like to remind you why biostructures need water in general and, moreover, some tritium (especially from the Mendeleev table)? Basically, in order to extract high-octave compounds in their non-inertial state, because the brain needs the so-called "**living water**" with specific energy characteristics parameters and states of tritium. The parameters that are set by the "**SvetL Programs**" (in a wide range) or the Session as an independent Program. The Brain receives the basic necessary energy feed out of this "**living water**" and not only feed, but uses energy of only specific frequencies (non-inertial mass), which characterize all the features of its activity in restoring lost abilities regarding the recovery of its "shirt" (body). And despite the difference in the Brain genotypes, it turns out that this "living pill" is **AS IF "GOOD" FOR EVERYONE**. But each person or a group of people different in the Brain genotypes who are present in the room with the Session on receives only those frequencies (octaves) of energy from the water on which their Brain works. I will not fail to say about the "Cupola DI", which is now being "tested". One complements the other. The effectiveness of using the Session in the "**Cupola DI**" coverage area and creating a personal liquid pill for each of those present is undoubtedly much better and more efficient, not to mention the Session itself.

All **N. Levashov's "Health Improving Sessions"**, created by him in his time and Beethoven's "Moonlight Sonata", in particular (converted into the "**Health Improving Session**") and hosted on a specially prepared server, which can be accessed by sites created by my colleagues. are able for incredible things in terms of people's getting over a great number of varieties of ailments, and most importantly, in my opinion, in addition to recovery, they are good in the development of Man, as evidenced by numerous reports submitted by the Users. **The Sessions are absolutely free and available to everyone** – I shall not fail to stress it here, against the background of those scandalous practices in our medicine and pharmacology. Take it for a "**magic wand**".

I thought to finish the chapter on this note, because I think that I gave exhaustive information and calculations in understanding what music is, what it was created for and how the Health Improving Site was created, but I realized that there must be at least a short story about The Man who had created the brilliant work, I used. Of course, a lot of books have been written about him and his genius and quite a lot of other information is available on the Internet. However, within the framework of today's transformations that are now manifested by the youth in such a thing – "As we know, Pushkin is

one of the great writers of the 20th century" or "Pushkin was born in Moscow, married, gave birth to children and fought a duel when they shot from a pistol", I decided to remind the readers, nevertheless, who was **Ludwig van Beethoven** when he lived on this earth and what he did on it...

7.7. He touched my ears...



Ludwig van Beethoven was born on **December 16, 1770** in a poor quarter of Bonn (Germany). The boy's grandfather and father were endowed with singing talent, so they worked in the court chapel. It's hard to call Ludwig's childhood happy, because a constantly drunk father and a beggarly existence do not contribute to the development of talent, but already at an early age Ludwig shows talent for music. His father notices this and, envying the fame and talent of Amadeus Mozart, whose name resounds throughout Europe, decides to raise a similar genius from his own child. He forces him to practice on five instruments at once – organ, harpsichord, viola, violin and flute. The slightest mistake is punished by whipping and beatings. Already at the age of six, Ludwig, being forced by his father, gives a concert in Cologne.

Thanks to maternal support, the young genius begins to improvise and take notes on his own works. Nature has generously endowed the child with talent, but the development is difficult and painful. Ludwig gets so deep in the melodies created in his mind that he can not get out of this state on his own. In 1782, Christian Gotlobo is appointed director of the court choir, who become Louis's teacher. The man could see in the young man glimpses of natural gifts and got engaged in his education. Realizing that musical skills do not give full development, he instills in Ludwig love of literature,

philosophy and ancient languages. Schiller, Goethe, Shakespeare become the idols of the young genius. Beethoven eagerly studied the works of Bach and Handel, dreaming of working together with Mozart.

The musical capital of Europe, Vienna, the young man first visits in 1787, where he meets Wolfgang Amadeus. The famous composer, having heard the improvisation of Ludwig, is delighted. Mozart says in amazement: "Do not take your eyes off this boy. One day the world will talk about him". In the world musical capital, Vienna, Beethoven is accepted as a genius. He is shocked immediately. He is healthy, happy, accepted, understood, begins to compose music, and goes to study to the greatest teacher – Antonio Salieri. He composes a lot. Beethoven's music is algebra and harmony! Everything is precisely calculated, absolutely perfect, everything is predictable! For the composer, it is just a great period of life. He is not yet that wild man whom we will call Beethoven, a titan, a fighter. A year later, Ludwig van Beethoven creates music for the "Ode of Joy", written by Schiller in 1785 for the Masonic Lodge. Throughout his life, the maestro modifies the anthem, striving for the triumphal sound of the composition. But the public hears the symphony, which causes furious delight, only in May 1824. Soon Beethoven becomes the most popular pianist of Vienna. In 1795, there is a debut of a young musician. Having played three piano trios and three sonatas of his own composition, he charms contemporaries. The participants note his stormy temperament, the richness of imagination and the depth of Ludwig's feelings. Three years later, he is overtaken with a terrible disease – tinnitus⁸⁷, which usually develops slowly but surely. He begins to lose his hearing. After this blow, Beethoven will never be as he used to be before. This will be his completely new quality. Beethoven hides his indisposition for 10 years. The surrounding people do not even guess about the beginning of the pianist's deafness, and his slips of the tongue and answers irrelevantly attributed to confusion and inattention. However, this does not stop him from composing new works that astonish listeners with their depth! How to understand the Beethoven effect? And suddenly, unexpectedly, this effect sounds from another creator, in another country, in a different culture – Alexander Pushkin. You remember – **The Prophet**, don't you?

...He touched my ears, –

And they were filled with noise and ringing:

⁸⁷ Tinnitus (from the Latin. Tinnire, which means "to jingle or ring like a bell") is ringing or noise in the ears.

*And I listened to the sky shudder,
And the high flight of angels,
And reptile marine underwater course,
And a valley's vine becoming wild...*

When the angel touched the ears of the prophet, from the earthly point of view, **HE WAS BECOMING DEAF**, but he heard visible images of sounds and saw them with his Brain. This is how composing music for Beethoven turned into a "selection" of a palette of light effects associated with sensations, which were laid in the work and expressed in a specific melody (sound) in the depths of his Brain. If you listen to fragments from Beethoven's sonatas that he composed throughout his life – from the all round and perfect hearing to the time when he was already utterly deaf, then you can hear the Beethoven effect: "The worse we hear, the closer to the heavens! To the Eternity!"

When Beethoven became deaf he was constantly thinking of suicide. What is a composer without hearing? Life is over! And here, fortunately, Beethoven discovers for himself *Niccolò Machiavelli*, an Italian of the Renaissance, who lived 300 years before him. Losing hope, he opened the book "*Sovereign*", which read that it had always been considered – destiny and God decide human life, and man has no right to change or cancel anything. Man only half depends on fate, and the second half depends on his individual qualities. Individual qualities can conquer fate. Encouraged by those words, he wrote the famous Appassionato with episodes in which the flows of sounds flooding,

storming, destroying, free from obstacles suddenly turn into peace, because a resistance motive appears – a human arrow in the dam construction. Two years later, Beethoven still hears, although he has to look at the speaker's lips, but he hears melodies a little more "from afar", making them more and more beautiful. And when Beethoven learns from doctors that deafness will be absolute, he does not want to believe it. Now he is trying to fight it. He fights. And he composes amazing music – Spring Sonata for violin and piano.

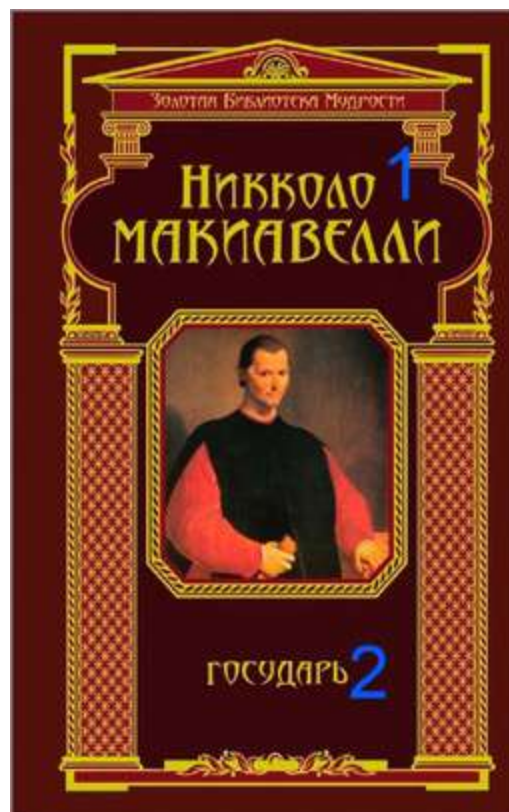

And the melody that opens the sonata is the last melody that Beethoven hears. The music of the Spring Sonata is one of the most beautiful melodies created by Beethoven. Beethoven is deaf. He communicates through conversational notebooks. Now he composes a lot of music – entirely different music.

Moonlight Sonata (Sonata for Piano No. 14 in C sharp minor, op. 27, No. 2 (Quasi fantasia)) is composed in the years 1800-1801. When he is creating this work, he is 31 years old, and he almost lost his hearing. He sees what he writes. It is this nuance that prompted me to accompany the Sonata's music with the generation image. I am more than sure that it is the vision of music and the construction of it within the framework of color, not sound, that allowed Beethoven's Brain using (unconsciously) **note Na**.

Why it is in this work, but not in the next ones – I don't know, but I know that practically at the same time, **Niccolò Paganini**⁸⁸, when playing violin, also unconsciously reproduced **note Na**, to the sound of which the people in the hall stood up from their seats.



For millions of people around the world, the Moonlight Sonata is the most favorite composition of classical music. But most of them do not even suspect that their admiration is connected precisely with the sound of **note Na** in it and the actual healing effect for the listeners. The sonata has nothing to do with the Moon. It is created in relation to Beethoven's love experience. This name is **GIVEN NOT BY Beethoven HIMSELF**, but after his death **by the critic Ludwig Rielshab**. The composer gave this composition the name "Sonata in the spirit of fantasy".

Three years before his passing away, Beethoven, through the musical testament, announced to mankind about that great joy that awaits him, which is sure to come. The Thought on the earth must win. Only the Mind,

⁸⁸ **Niccolò Paganini** (10/27; 1782; Genoa – 27.05. 1782, Nice) – the great Italian violin virtuoso, composer.

the Knowledge can conquer both death and destruction. This is evolution, which Beethoven went through music, or rather, his Brain – as a man, as a musician, as the greatest composer, the unsurpassed genius of musical thinking, writing great music, being utterly deaf. How could there be so much music and so much great secret knowledge in one person? I think that this chapter will give you the answer, if you, of course, read it carefully and have a good look at ***the Appendix to it.***

7.8. Afterword for the thought

The very first musical instruments that imitate the sounds of Nature are tambourines, the simplest wooden pipes, and bells. But with time, musical instruments were becoming more complex, and with their development, special places appeared for performing music. At first they were religious temples and places of worship, and later – amphitheatres, perfect in terms of acoustics. But the most interesting is that the science of acoustics, as such, did not exist, and amphitheatres were built in different places (countries) as a carbon copy, with minor differences in architecture, **KEEPING UNCHANGEABLE – THE DESIGN** of the bowl, in which people were sitting. The first known experiments related to music and acoustics, appeared in the VI century BC. in Greece. They were conducted by Pythagoras and his disciples. The musical theory of Pythagoras was not limited to the search for harmonious combinations of sounds and their mathematical parameters. His concept also included ideas about the harmony of the Universe, the unity of God, music and mathematics. This was the beginning of the use of music in the formation of specific Brain genotypes in humans, as one of the most important instruments. At about the same time in China, **Emperor Huang Di** (to be more accurate, his assistant) invented his musical system. Like the Pythagorean, it was perfectly mathematically constructed. Moreover, the musical order of **Pythagoras and Huang Di** coincide with the accuracy of detail. But as you understand, the Internet and e-mail were not yet in the project. Many philosophers and historians call the time in the region of the VI century BC. "Axial time", a period when, **SIMULTANEOUSLY**, powerful philosophical, religious, scientific schools originated **AT DIFFERENT POINTS OF THE WORLD**. This is the time when Pythagoras, Gautama Buddha, Confucius and Lao Tzu lived. Confucius, for example, significantly expanded and deepened the use of music in various fields. It was even created a **whole**

ministry of music of Yuefu (Chamber of Music), responsible for proper tuning forks of musical instruments in China. It also saw to it that when performing the "right" rituals, there should be performed the "right" music.

The same thing happens at the same time in India, in the Middle East, in Egypt and other places, as if by command of someone – "everyone should do the same..." This suggests that since ancient times great importance was attached to music, up to the level of state ideology and it dominated in high society then (i. e. – created by the highest Brain genotype at that time), philosophy and religion. And all this had happened up to the XII century, before in Europe G. Galileo said that the future development of science as a whole was in the study of vibratory processes. He was, perhaps, the first scientist of the New Time, who tried to connect music, as art, with physics and mathematics. And only in the **19th century**, G. Helmholtz and D. W. Rayleigh created teaching on acoustics, which, by and large, "led people away" from the desire to cognize the effect of music on Man as a whole, and made it possible to begin taking music for an instrument of direct influence on people with definite purpose.

In China, a very "strange" story took place. ***In the 6th century BC***, Confucius collected **FIVE THE MOST IMPORTANT TREATISES**, which were most significant from the point of view of philosophy and human development in the future. This is the so-called "***Confucian Pentateuch***". It included the treatise "***Yue Jing***", dedicated to music, often mentioned in other manuscripts. ***But in the IV century BC. some "knowing people" withdrew this treatise from all libraries and eliminated it***, on the pretext that there were no "knowledgeable" people left, and senseless use of the "knowledge" given in the treatise, might lead to destruction (no more and no less) of all human society, to wars and other human cataclysms. ***One way or another, only fragments of "Yue Jing" are currently available...***

Music is a vibrating energy, a mighty vibration that, through certain people, who we call brilliant composers, comes from space, there is no verblativity in it, there is no visual series, but there is only an overtone wave of the Universe, in which there are codes of immortality, codes of genius, ***codes of human evolution***. This vibrating transmitter through these geniuses gives our Brain, the organism, our Spirit a gigantic connection with the idea of cosmicity, significance, and harmony.

With all one's spiritual beginning, not for reasons and the need for survival, but by virtue of one's own conscious professional usefulness, Man

must voluntarily strive for ***devoting oneself to everyone***, feeling one's primary beginning in social organization. Only to such an aspiring state Man is brought by the System by giving the Brain higher octaves, making him free of the animal state – to be used. ***And N. Levashov's Technologies and the Sessions – will render assistance.***

APPENDIX 1**The Table – musical series of chemical elements for the temperature of the element decomposition**

No	Element	Isoster	Base octave	Tone	P ₁	P ₂	P ₃	P ₄	P ₅	Vibrations per second (Hz)
4	H		53							
5			52	mi	+					
6			52	sol		+				
7			52	si			+			
8			50	la				+		
8	He		51							
9			49	re	+					
10			49	mi		+				
11			49	fa			+			
12			49	sol				+		
12	Li		50							
13			44	re	+					
14			44	mi		+				
15			44	mi			+			
16			44	mi				+		
16	Be		49							
17			48	re	+					
18			48	mi		+				
19			48	fa						
20			48	mi						
21			48	re						
22			48	fa			+			
23			48	sol						
24			48	sol			+			
25			48	la						
26			48	la				+		
27			48	la					+	
28			48	si						
29			46	fa						
30			46	fa			+			
31			46	sol						
32			46					+		
20	B		44	re						
21			48		+					
22			48			+				
23			48				+			
24			48					+		
25			48						+	
26			48	fa			+			

27			48		+					
28			48	si					+	
29			48	mi						
30			47		+					
31			47			+				
32			47				+			
24	C		44							
25			42				+			
26			42	la						
27			42	sol						
28			42	fa						
28	N		41							
29			41	fa						
30			41	mi						
31			41	re						
32			41				+			
32	O		40							
33			40	re						
34			40	mi						
35			40	fa						
36			40	sol						
36	F		39							
37			39	re						
38			39	mi						
39			39	fa						
40			39	sol						
40	Ne		52							
41			52	re						
42			52	mi						
43			52	fa						
44			52	sol						
44	Na		48							
45			48	re						
46			48	mi						
47			48	fa						
48			48	sol						
48	Mg		46							
49			46	re						
50			46	mi						
51			46	fa						
52			46	sol						
52	Al		54							
53			54	re						
54			54	mi						
55			54	fa						
56			54	sol						

56	Si		52	fa						
57			52	re						
58			52	mi						
59			52	fa						
60			52	sol						
61			52	la						
62			52	si						
63			52		+					
65			52			+				
66			52				+			
67			52					+		
69			52						+	
70			52		+					
71			52	re	+					
73			52	re		+				
74			52	mi		+				
75			52	fa			+			
76			52	sol			+			
77			52	sol				+		
78			52	la				+		
79			52	la					+	
80			52	si					+	
60	P		53							
61			53	re						
62			53	mi						
63			53	fa						
64			53	sol						
64	S		51							
65			51	re						
66			51	mi						
67			51	fa						
68			51	sol						
68	Cl		55							
69			55	re						
70			55	mi						
71			55	fa						
72			55	sol						
72	Ar		54							
73			54	fa						
74			54	la						
80	Ca		53	mi						
81			53		+					
82			53	re	+					
83			53	re		+				
84			53	mi		+				
87			53	fa			+			

88			53				+			
91			53	sol			+			
92			53					+		
95			53	la				+		
96			53	la					+	
99			53						+	
100			53	si					+	
103			52		+					
104			52	re	+					
107			52	mi	+					
108			52	fa			+			
111			52				+			
112			52	sol			+			
115			52	sol				+		
116			52					+		
119			52	la				+		
120			52	la					+	
123			52						+	
124			52	si					+	
127			51		+					
128			51	fa						
84	Sc		47	la						
85			47	sol						
86			47	fa						
88	Ti		47	mi						
89			47	re		+				
90			47	re	+					
92	V		47	si						
93			47	si					+	
94			47						+	
96	Cr		47	si						
97			46	si					+	
98			46						+	
100	Mn		46	re						
101			46	re		+				
102			46	mi		+				
104	Fe		46	sol						
105			46	sol				+		
106			46					+		
108	Co		46	mi						
109			46	mi		+				
110			46			+				
112	Ni		46	fa						
113			46	fa			+			
114			46				+			
116	Cu		45	re						

117			45	re		+				
118			45			+				
120	Zn		45	fa						
121			45	fa			+			
122			45				+			
124	Ga		45	sol						
125			45	sol				+		
126			45					+		
128	Ge		45	la						
129			45	la					+	
130			45						+	
132	As		44	fa						
133			44	mi		+				
134			44	re		+				
135			44	re	+					
136			44		+					
136	Se		44	la						
137			44	la				+		
138			44					+		
139			44	la					+	
140			44						+	
140	Br		44	mi						
141			44	mi		+				
142			44			+				
143			44	re	+					
144			44		+					
144	Kr		51	mi						
145			51	fa						
146			51	sol						
147			51	la						
148			51	si						
148	Rb		51	re						
149			51	mi		+				
150			51			+				
151			51	re		+				
152			51		+					
152	Sr		51	sol						
153			51				+			
154			51	sol			+			
155			51	sol				+		
156			51						+	
156	Y		51	la						
157			51	la				+		
158			51	la					+	
159			51						+	
160			51	si					+	

163			51	si						
164			50		+					
167			50	re	+					
168			50	re		+				
171			50	mi		+				
172			50	fa			+			
175			50	sol			+			
176			50	sol				+		
179			50					+		
180			50	la				+		
183			50						+	
184			50	la					+	
187			50	si					+	
188			49		+					
191			49	re		+				
192			49			+				
195			49	mi		+				
196			49	fa			+			
199			49				+			
200			49	sol			+			
203			49	sol				+		
204			49					+		
207			49	la				+		
208			49	la					+	
211			49	si					+	
212			49						+	
160	Zr		52	re						
161			52	re	+					
162			52	re		+				
164	Nb		52	mi						
165			52			+				
166			52	mi		+				
168	Mo		52	fa						
169			52	fa			+			
170			52				+			
172	Tc		52	sol						
173			52	sol			+			
174			52	sol				+		
176	Ru		52	la						
177			52	la				+		
178			52	la					+	
180	Rh		52	si						
181			52						+	
182			52	si					+	
184	Pd		46	re						
185			46	re		+				

186			46	re	+					
188	Ag		46	mi						
189			46			+				
190			46	mi		+				
192	Cd		46	fa						
193			46	fa			+			
194			46				+			
196	In		46	sol						
197			46	sol			+			
198			46	sol				+		
200	Sn		46	la						
201			46	la				+		
202			46	la					+	
204	Sb		46	si						
205			46	si					+	
206			46						+	
208	Te		46							
209			46		+					
210			46		+					
212	I		50	si						
213			50						+	
214			50	si					+	
216	Xe		52	re						
217			52	re		+				
218			52	re	+					
219			52		+					
220			52			+				
220	Cs		52	mi						
221			52			+				
222			52	mi		+				
223			52	fa			+			
224			52				+			
224	Ba		52	fa						
225		La	49	re						
226		Ce	49	mi						
227		Pr	49	fa						
228	Nd		52	sol						
229		Pm	49	sol						
230		Sm	49	la						
231		Eu	49	si						
232	Gd		52	la						
233		Tb	48	re						
234		Dy	48	mi						
235		Ho	48	fa						
236	Er		52	si						
237		Tm	48	sol						

238		Yb	48	la						
239			48	si						
240			52	si						
240	Lu		51	re						
241			52	fa			+			
242			52				+			
243			52	sol			+			
244			52	sol				+		
247			52					+		
248			52	la				+		
251			52	la					+	
252			52						+	
255			52	si					+	
256			51	re	+					
259			51		+					
260			51	re		+				
263			51			+				
264			51	mi		+				
267			51	fa			+			
268			51				+			
244	Hf		51	mi						
245			51	mi		+				
246			51			+				
248	Ta		51	fa						
249			51	fa			+			
250			51				+			
252	W		51	sol						
253			51	sol				+		
254			51					+		
256	Re		51	la						
257			51	la					+	
258			51						+	
260	Os		51	si						
261			51	si					+	
262			50		+					
264	Ir		50	re						
265			50	re	+					
266			50		+					
268	Pt		50	mi						
269			50			+				
270			50	mi		+				
272	Au		50	fa						
273			50	re	+					
274			50		+					
275			50	re		+				
276			50			+				

276	Hg		50	sol						
277			50				+			
278			50	sol			+			
279			50	sol				+		
280			50					+		
280	Tl		50	la						
281			50	la				+		
282			50					+		
283			50	la					+	
284			50						+	
284	Pb		50	si						
285			50	si					+	
286			50						+	
287			49		+					
288			49		+					
288	Bi		54	la						
289			54	la				+		
290			54	la					+	
292	Po		54	re						
293			54	re	+					
294			54	re		+				
295			54		+					
296			54		+					
296	At		54	mi						
297			54			+				
298			54	mi		+				
299			53		+					
300			53		+					
300	Rn		54	fa						
301			54	fa			+			
302			54				+			
303			53	fa			+			
304			53				+			
304	Fr		54	sol						
305			54	sol			+			
306			54	sol				+		
307			53	sol			+			
308			53	sol				+		
308	Ra		54	la						
309			54	la				+		
310			54	la					+	
311			53	la				+		
312			53	la					+	
312	U		54	si						
313		Np	44	re						
314		Pu	44	mi						

315		Am	44	fa										
316	Cm		55	re										
317		Bk	44	sol										
318		Cf	44	la										
319		Es	44	si										
320	Fm		55	mi										
321		Md	45	re										
322		No	45	mi										
323		Lr	45	fa										
324	Ns		55	fa										
325		Ku	45	sol										
326			45	la										
327			45	si										

APPENDIX 2

The clarified musical series of chemical elements

No	Element	Isoster	Base octave	Tone	P ₁	P ₂	P ₃	P ₄	P ₅	P ₆	P ₇	P ₈	No of the Forth	Vibrations per second (Hz)
4	H	*	53	Do										
5			52	Mi										
6			52	Sol										
7			52	Si										
8		*	51	Re										
8	He	*	51	Do										
9			49	Mi										
10			49	Sol										
11			49	Si										
12			48	Re										
12	Li	*	50	Do										
13			48	Mi										
14			48	Sol										
15			48	Si										
16			47	Re										
16	Be	*	49	Do										
17			48	Do	+									
18			48		+									
19			48	Re	+									
20			48	Re		+								
21			48			+								
22			48	Mi		+								
23			48	Mi			+							
24			48				+							
25			48	Fa			+							

26			48	Fa				+							
27			48					+							
28			48	Sol				+							
29			47	Sol					+						
30			47						+						
31			47	La					+						
32			47	La						+					
20	B	*	46	Do											
21			45	Do	+										
22			45		+										
23			45	Re	+										
24			45	Re		+									
25			45			+									
26			45	Mi		+									
27			45	Mi			+								
28			45				+								
29			45	Fa			+								
30			45	Fa				+							
31			45					+							
32			45	Sol				+							
24	C	*	45	Do											
25			44	Do	+										
26			44	Re		+									
27			44	Mi			+								
28			44	Fa				+							
28	N	*	44	Do											
29			43	Do	+										
30			43	Re		+									
31			43	Mi			+								
32			43	Fa				+							
32	O	*	43	Do											
33			42	Do	+										
34			42	Re		+									
35			42	Mi			+								
36			42	Fa				+							
36	F	*	42	Do											
37			41	Do	+										
38			41	Re		+									
39			41	Mi			+								
40			41	Fa				+							
40	Ne	*	41	Do											
41			40	Do	+										
42			40	Re		+									
43			40	Mi			+								
44			40	Fa				+							
44	Na	*	40	Do											

45			39		+												
46			39			+											
47			39				+										
48			39					+									
48	Mg	*	39	Do													
49			38		+												
50			38			+											
51			38				+										
52			38					+									
52	Al	*	54	Do													
53			53		+												
54			53			+											
55			53				+										
56			53					+									
56	Si	*	52	Do													
57			51	Do	+												
58			51	Re	+												
59			51	Re		+											
60			51	Mi		+											
61			51	Mi			+										
62			51	Fa			+										
63			51	Fa				+									
65			51	Sol				+									
66			51	Sol					+								
67			51	La					+								
69			51	La						+							
70			51	Si						+							
71			51	Si							+						
73			51	Na							+						
74			51	Na								+					
75			52		+												
76			52			+											
77			52				+										
78			52					+									
79			52						+								
80			52							+							
60	P	*	50	Re													
61			50	Mi		+											
62			50	Mi			+										
63			50	Fa			+										
64			50	Fa				+									
64	S	*	48	Do													
65			47	Do	+												
66			47	Re	+												
67			47	Re		+											
68			47	Mi		+											

68	Cl	*	47	Do															
69			46	Do	+														
70			46	Re	+														
71			46	Re		+													
72			46	Mi		+													
72	Ar	*	38	Do															
73			37	Do	+														
74			37	Re	+														
80	Ca	*	37	Do															
81			36	Do	+														
82			36	Re	+														
83			36	Re		+													
84			36	Mi		+													
87			36	Mi			+												
88			36	Fa			+												
91			36	Fa				+											
92		*	36	Sol				+											
95			36	Sol					+										
96		*	36	La					+										
99			36	La						+									
100		*	36	Si							+								
103			35		+														
104			35			+													
107			35				+												
108		*	35					+											
111			35						+										
112		*	35							+									
115			35								+								
116			35									+							
119			35	Fa															
120		*	35	Sol															
123			35	La															
124			35	Si															
127			35	Na															
128		*	36	Do															
84	Sc		37	Mi															
85			36				+												
86		*	36	Fa															
88	Ti	*	46	Re															
89			45						+										
90			45							+									
92	V	*	46	Mi															
93			45	La					+										
94			45	La						+									
96	Cr		46	Sol															

97		*	45	Si						+			
98			45	Si							+		
100	Mn		44	Re									
101			43			+							
102			43	Mi									
104	Fe		45	Re									
105		*	44				+						
106			44	Si									
108	Co	*	46	La									
109			45								+		
110			45	Na									
112	Ni	*	45	Si									
113			44								+		
114			44									+	
116	Cu		44	Na									
117			43	Na								+	
118		*	43									+	
120	Zn		45	Mi									
121		*	44					+					
122			44	Sol				+					
124	Ga		47	Sol									
125		*	46						+				
126			46	La					+				
128	Ge		47	Mi									
129		*	46	Mi			+						
130			46				+						
132	As		44	Mi									
133		*	43				+						
134			43	Fa									
135			43					+					
136			43	Sol									
136	Se		44	Sol									
137		*	43						+				
138			43	La									
139			43							+			
140			43	Si									
140	Br		44	La									
141			43								+		
142			43	Na							+		
143		*	43	Na									
144			43	Do 1								+	
144	Kr		51	Mi									
145		*	50				+						
146			50					+					

147			50						+					
148			50							+				
148	Rb		51	Sol										
149		*	50	La					+					
150			50							+				
151			50	Na							+			
152			50	Na								+		
152	Sr		51	Si										
153		*	50	Si							+			
154			50								+			
155			50	Na										
156			50									+		
156	Y		50	Mi										
157			49	Mi			+							
158			49				+							
159			49	Fa			+							
160			49	Fa				+						
163			49					+						
164			49	Sol				+						
167			48	Sol					+					
168			48						+					
171			48	La					+					
172			48	La						+				
175			48							+				
176			48	Si						+				
179			48	Si							+			
180			48								+			
183			48	Na							+			
184			48	Na								+		
187			48									+		
188		*	47		+									
191			47			+								
192			47				+							
195			47					+						
196			47	Sol				+						
199			47							+				
200			47								+			
203			47									+		
204			47	Si							+			
207			47	Na							+			
208			47	Na										
211			47	Na								+		

212			47	Mi			+							
160	Zr		50	Sol										
161		*	49	Sol					+					
162			49						+					
164	Nb		49	Re										
165		*	48	Re			+						6	
166			48	Mi			+						7	
168	Mo		48	La										
169			47	Si			+						23	
170		*	47	Si									24	
172	Tc		48	Na										
173		*	47									+	30	
174			47	Do 1								+	31	
176	Ru		48	Fa										
177		*	47	Fa				+					14	
178			47	Sol				+					15	
180	Rh		47	Si										
181		*	46									+		
182			46	Na								+		
184	Pd		47	Fa										
185		*	46	Fa				+						
186			46					+						
188	Ag		46	Si										
189		*	45	Na								+		
190			45	Na									+	
192	Cd		47	La										
193		*	46	La								+		
194			46									+		
196	In	*	46	Fa										
197			45	Sol					+					
198			45	La										
200	Sn		46	Na										
201			45										+	
202		*	45	Do 1									+	
204	Sb		45	Sol										
205			44	Sol						+				
206		*	44							+				
208	Te		45	Fa										
209		*	44	La						+				

210			44	La						+			
212	I		44	Fa									
213		*	43	Sol				+					
214			43	Sol					+				
216	Xe		52	Re									
217		*	51				+						
218			51					+					
219			51						+				
220			51							+			
220	Cs		52	Fa									
221		*	51	La									
222			51							+			
223			51								+		
224			51	Na									
224	Ba	*	49	Fa									
225		La *	49	Fa									13
226		Ce *	49	Fa				+					14
227		Pr *	49					+					15
228	Nd	*	49	La									
229		Pm *	49	La									21
230		Sm *	49							+			22
231		Eu *	49							+			23
232	Gd	*	49	Na									
233		Tb *	49	Na									29
234		Dy *	49								+		30
235		Ho *	49								+		31
236	Er	*	50	Fa									
237		Tm *	49	Sol									16
238		Yb *	49	Sol									17

23 9			49						+				18	
24 0			50	La										
24 0	Lu		50	Si										
241		*	49	Si									25	
24 2			49	Si							+			
24 3			49								+		26	
24 4			49								+			
247			49								+		27	
24 8			49	Na							+			
251			49	Na									28	
25 2			49	Na									29	
255			49	Na							+			
25 6			49								+		30	
25 9			49								+		31	
26 0			48	Si									25	
26 3			48								+		26	
26 4			48								+		27	
267			48	Na									28	
26 8			48	Na									29	
24 4	Hf		52	La										
24 5		*	51	La									21	
24 6			51								+		22	
24 8	Ta	*	53	Re										
24 9			52	Re					+					
25 0			52	Mi					+					
25 2	W	*	53	Mi										

253			52	Mi			+						
254			52	Fa			+						
256	Re		53	Fa									
257			52	Fa				+					
258		*	52	Sol				+					
260	Os		53	Sol									
261		*	52	Sol					+				
262			52	La					+				
264	Ir		53	La									
265		*	52	La						+			
266			52	Si						+			
268	Pt		53	Si									
269		*	52	Si							+		
270			52								+		
272	Au		42	Re									
273		*	41				+						
274			41	Mi			+						
275			41					+					
276			41	Fa				+					
276	Hg		42	Mi									
277		*	41	Fa									
278			41						+				
279			41	Sol					+				
280			41	Sol									
280	Tl		40	La									
281		*	39	La							+		
282			39								+		
283			39	Si							+		
284			39	Si									

28 4	Pb		38	Si										
28 5		*	37	Si							+			
28 6			37								+			
28 7			37	Na							+			
28 8			37	Na										
28 8	Bi	*	37	La										
28 9			36								+			
29 0			36	Si										
29 2	Po	*	56	Do										
29 3			55	Do	+									
29 4			55		+									
29 5			55	Re	+									
29 6			55	Re										
29 6	At	*	55	Do										
297			54	Do	+									
29 8			54		+									
29 9			54	Re	+									
30 0			54	Re										
30 0	Rn	*	57	Re										
301			56	Re		+								
30 2			56			+								
30 3			56	Mi		+								
30 4			56	Mi										
30 4	Fr	*	57	Do										

305			56	Do	+														
306			56		+														
307			56	Re	+														
308			56	Re															
308	Ra	*	58	Do															
309			57	Do	+														
310			57		+														
311			57	Re	+														
312			57	Re															
312	U	*	59	Do															
313		Np *	58	Do	+														
314		Pu *	58		+														
315		Am *	58	Re	+														
316	Cm	*	59	Re															
317		Bk *	58	Re		+													
318		Cf *	58			+													
319		Es *	58	Mi		+													
320	Fm	*	59	Mi															
321		Md *	58	Mi			+												
322		No *	58				+												
323		Lr *	58	Fa			+												
324	Ns	*	59	Fa															
325		Ku *	58	Fa				+											
326			58						+										
327			58	Sol						+									

(*) The elements corresponding to the Periodic Table.

Note that the "Maxim table" is far from complete. The following table shows the qualitative distribution of the elements by frequencies.

Columns 4 to 16 – the octave number.

No. Ch – addition to a tone and semitone – number of a fourth.

	Tone, semitone	No Ch	35	36	37	38	39	40	41	42
--	----------------	-------	----	----	----	----	----	----	----	----

F. Shkrudnev N. Levashov's "SvetL Broom" in A. Khatybov's "Bath School" and A Labour Spade

1	Do			Ca128	Ca80	Ar72	Mg48	Na44	Ne40	F36
2		1								
3	Do+P1			Ca81	Ar73			Ne41	F37	O33
4		2								
5	P1		Ca103			Mg49	Na45			
6		3								
7	Re+P1			Ca82	Ar74					
8		4								
9	Re									Au272
10		5								
11	Re+P2			Ca83				Ne42	F38	O34
12		6								
13	P2		Ca104			Mg50	Na46		Au273	
14		7								
15	Mi+P2			Ca84					Au274	
16		8								
17	Mi				Sc84					Hg276
18		9								
19	Mi+P3			Ca87				Ne43	F39	O35
20		10								
21	P3		Ca107	Sc85		Mg51	Na47		Au275	
22		11								
23	Fa+P3			Ca88					Au276	
24		12								
25	Fa		Ca119	Sc86				Hg277		
26		13								
27	Fa+P4			Ca91				Ne44	F40	O36
28		14								
29	P4		Ca108			Mg52	Na48	Hg278		
30		15								
31	Sol+P4			Ca92				Hg279		
32		16								
33	Sol		Ca120					Hg280		
34		17								
35	Sol+P5			Ca95						
36		18								
37	P5		Ca111							
38		19								
39	La+P5			Ca96						
40		20								
41	La		Ca123		Bi288			Tl280		
42		21								
43	La+P6			Ca99				Tl281		
44		22								
45	P6		Ca112	Bi289				Tl282		
46		23								
47	Si+P6			Ca100				Tl283		
48		24								
49	Si		Ca124	Bi290		Pb284	Tl284			
50		25								
51	Si+P7				Pb285					
52		26								
53	P7		Ca115		Pb286					
54		27								
55	Na+P7				Pb287					
56		28								
57	Na		Ca127		Pb288					
58		29								
59	Na+P8									
60		30								

61	P8		Ca116							
62		31								
63	Do1+P8									

	Тон, полу- тон	№ Ch	43	44	45	46	47	48	49	50
1	Do		O32	N28	C24	B20	Cl68	S64	Be16	Li12
2		1								
3	Do+P1		N29	C25	B21	Cl69	S65	Be17		
4		2								
5	P1				B22		Y188	Be18		
6		3								
7	Re+P1				B23	Cl70	S66	Be19		
8		4								
9	Re			Mn100	Fe104	Ti88	Li14	He12	Nb164	P60
10		5								
11	Re+P2		N30	C26	B24	Cl71	S67	Be20		
12		6						Nb165		
13	P2		Mn101		B25		Y191	Be21		
14		7						Nb166		
15	Mi+P2				B26	Cl72	S68	Be22		P61
16		8								
17	Mi		Mn102	As132	Zn120	V92	Ge128	Li13	He9	Y156
18		9								
19	Mi+P3		N31	C27	B27	Ge129	Y212	Be23	Y157	P62
20		10								
21	P3		As133	Fe105	B28	Ge130	Y192	Be24	Y158	Kr145
22		11								
23	Fa+P3				B29			Be25	Y159	P63
24		12								
25	Fa		As134	I212	Te208	In196	Pd184	Ru176	Ba224	Er236
26		13							La225	
27	Fa+P4		N32	C31	B30	Pd185		Be26	Y160	P64
28		14					Ru177		Ce226	
29	P4		As135	Zn121	B31	Pd186	Y195	Be27	Y163	Kr146
30		15					Ru178		Pr227	
31	Sol+P4		I213	Zn122	B32		Y196	Be28	Y164	
32		16							Tm237	
33	Sol		As136	Se136	Sb204	Cr96	Ga124	Li14	He10	Zr160
34		17							Y238	
35	Sol+P5		I214	Sb205	In197		Be29	Y167	Zr161	
36		18							239	
37	P5		Se137	Sb206	Ti89	Ga125	Be30	Y168	Zr162	Kr147
38		19								
39	La+P5			Te209	V93	Ga126	Be31	Y171		Rb149
40		20								
41	La		Se138	Br140	In198	Co108	Cd192	Mo168	Nd228	Er240
42		21							Pm229	
43	La+P6			Te210	V94	Cd193	Be32	Y172		
44		22							Sm230	
45	P6		Se139		Ti90	Cd194	Y199	Y175		Kr148
46		23					Mo169		Eu231	
47	Si+P6				Cr97			Y176		Rb150
48		24					Mo170			
49	Si		Se140	Fe106	Ni112	Ag188	Rh180	Li15	He11	Lu240
50		25						Lu260	Lu241	

51	Si+P7				Cr98		Y204	Y179	Lu242	Sr153
52		26						Lu263	Lu243	
53	P7		Br141	Ni113	Co109	Rh181	Y200	Y180	Lu244	Sr154
54		27						Lu264	Lu247	
55	Na+P7		Br142		Ag189	Rh182	Y207	Y183	Lu248	Rb151
56		28						Lu267	Lu249	
57	Na		Br143	Cu116	Co110	Sn200	Y208	Tc172	Gd232	Sr155
58		29						Lu268	Lu252	
59	Na+P8		Cu117		Ag190		Y211	Y184	Lu255	Rb152
60		30					Tc173		Lu256	
61	P8		Cu118	Ni114	Sn201		Y203	Y187		Sr156
62		31					Tc174		Lu259	
63	Do1+P8		Br144		Sn208					

Nº	Тон, полу-тон	Nº Ch	51	52	53	54	55	56	57	58	59
1	Do		He8	Si56	H4	Al52	At296	Po292	Fr304	Ra308	U312
2		1									
3	Do+P1		Si57			At297	Po293	Fr305	Ra309	Np313	
4		2									
5	P1			Si75	Al53	At298	Po294	Fr306	Ra310	Pu314	
6		3									
7	Re+P1		Si58			At299	Po295	Fr307	Ra311	Am315	
8		4									
9	Re		H8	Xe216	Ta248	At300	Po296	Fr308	Rn300		Cm314
10		5									
11	Re+P2		Si59	Ta249				Rn301		Bk317	
12		6									
13	P2		Xe217	Si76	Al54			Rn302		Cf318	
14		7									
15	Mi+P2		Si60	Ta250				Rn303		Es319	
16		8									
17	Mi		Kr144	H5	W252			Rn304	Ra312		Fm320
18		9									
19	Mi+P3		Si61	W253						Md321	
20		10									
21	P3		Xe218	Si77	Al55					No322	
22		11									
23	Fa+P3		Si62	W254						Lr323	
24		12									
25	Fa			Cs220	Ra256						Ns324
26		13									
27	Fa+P4		Si63	Re257						Ku325	
28		14									
29	P4		Xe219	Si78	Al56					326	
30		15									
31	Sol+P4		Si65	Re258						327	
32		16									
33	Sol		Rb148	H6	Os260						
34		17									
35	Sol+P5		Si66	Os261							
36		18									
37	P5		Xe220	Si79							
38		19									
39	La+P5		Si67	Os262							
40		20									

41	La		Cs221	Hf224	Ir264						
42		21	Hf245								
43	La+P6		Si69	Ir265							
44		22	Hf246								
45	P6		Cs222	Si80							
46		23									
47	Si+P6		Si70	Ir266							
48		24									
49	Si		Sr152	H7	Pt268						
50		25									
51	Si+P7		Si71	Pt269							
52		26									
53	P7		Cs223	Pt270							
54		27									
55	Na+P7		Si73								
56		28									
57	Na		Cs224								
58		29	Tb233								
59	Na+P8		Si74								
60		30	Dy234								
61	P8										
62		31	Ho235								
63	Do1+P 8										

APPENDIX 3**"The Maxim Table", or The table of nuclear reactors regarding "The Invisible"**

Options in the group of atoms

No	Chemical element	Number of atoms	1	2	3	4	Base element	Stabile elements	Unstable elements
1	H	4	1	4	1	4	H ₄	5, 6, 7, 8	-
2	He	8	1	4	1	4	He ₈	9, 10, 11, 12,	
3	Li	12	1	4	1	4	Li ₁₂	14, 16	13, 15
4	Be	16	1	16	1	16	Be ₁₆	18, 20, 22, 24, 26, 28, 30, 32	17, 19, 21, 23, 25, 27, 29, 31
5	B	20	1	12	1	12	B ₂₀	22, 24, 26, 28, 30, 32	21, 23, 25, 27, 29, 31
6	C	24	1	4	1	4	C ₂₄	25, 26, 27, 28, 29, 30, 31	-
7	N	28	1	4	1	4	N ₂₈	30, 32	29, 31
8	O	32	1	4	1	4	O ₃₂	33, 34, 35, 36	-
9	F	36	1	4	1	4	F ₃₆	-	37, 38, 39, 40
10	Ne	40	1	4	1	4	Ne ₄₀	42, 44	41, 43
11	Na	44	1	4	1	4	Na ₄₄	46, 48	45, 47,
12	Mg	48	1	4	1	4	Mg ₄₈	50, 52,	49, 51
13	Al	52	1	4	1	4	Al ₅₂	54, 56	53, 54
14	Si	56	-	21	-	21	Si ₅₆	58, 60, 62, 66, 70, 74, 76, 78, 80	57, 59, 61, 63, 65, 67, 69, 71, 73, 75, 77, 79
15	P	60	-	4	-	4	P ₆₀	62, 64	61, 63
16	S	64	-	4	-	4	S ₆₄	66, 68	65, 67
17	Cl	68	-	4	-	4	Cl ₆₈	70, 72	69, 71
18	Ar	72	-	2	-	2	Ar ₇₂	73, 74	
19	K	76	-	2	-	2	K ₇₆	78	77
20	Ca	80	-	26	-	26	Ca ₈₀	82, 84, 88, 92, 96, 100, 104, 108, 112, 116, 120, 124, 128	81, 83, 87, 89, 91, 95, 99, 103, 107, 111, 115, 119, 123, 127
21	Sc	84	-	2	-	2	Sc ₈₄	86	85
22	Ti	88	-	2	-	2	Ti ₈₈	90	89
23	V	92	-	2	-	2	V ₉₂	94	93
24	Cr	96	-	2	-	2	Cr ₉₆	98	97
25	Mn	100	-	2	-	2	Mn ₁₀₀	102	101
26	Fe	104	-	2	-	2	Fe ₁₀₄	106	105
27	Co	108	-	2	-	2	Co ₁₀₈	110	109

28	Ni	112	-	2	-	2	Ni ₁₁₂	114	113
29	Cu	116	-	2	-	2	Cu ₁₁₆	118	117
30	Zn	120	-	2	-	2	Zn ₁₂₀	122	121
31	Ga	124	-	2	-	2	Ga ₁₂₄	126	125
32	Ge	128	-	2	-	2	Ge ₁₂₈	130	129
33	As	132	-	4	-	4	As ₁₃₂	134, 136	133, 135
34	Se	136	-	4	-	4	Se ₁₃₆	138, 140	137, 139
35	Br	140	-	4	-	4	Br ₁₄₀	142, 142	141, 143
36	Kr	144	-	4	-	4	Kr ₁₄₄	146, 148	145, 147
37	Rb	148	-	4	-	4	Rb ₁₄₈	150, 152	149, 151
38	Sr	152	-	4	-	4	Sr ₁₅₂	154, 156	153, 155
39	Y	156	-	30	-	30	Y ₁₅₆	158, 160, 164, 168, 172, 176, 180, 184, 188, 192, 196, 200, 204, 208, 212	157, 159, 163, 167, 171, 175, 179, 183, 187, 191, 195, 199, 203, 207, 211
40	Zr	160	-	2	-	2	Zr ₁₆₀	162	161
41	Nb	164	-	2	-	2	Nb ₁₆₄	166	165
42	Mo	168	-	2	-	2	Mo ₁₆₈	170	169
43	Tc	172	-	2	-	2	Tc ₁₇₂	174	173
44	Ru	176	-	2	-	2	Ru ₁₇₆	178	177
45	Rh	180	-	2	-	2	Rh ₁₈₀	182	181
46	Pd	184	-	2	-	2	Pd ₁₈₄	186	185
47	Ag	188	-	2	-	2	Ag ₁₈₈	190	189
48	Cd	192	-	2	-	2	Cd ₁₉₂	194	193
49	In	196	-	2	-	2	In ₁₉₆	198	197
50	Sn	200	-	2	-	2	Sn ₂₀₀	202	201
51	Sb	204	-	2	-	2	Sb ₂₀₄	206	205
52	Te	208	-	2	-	2	Te ₂₀₈	210	209
53	I	212	-	2	-	2	I ₂₁₂	214	215
54	Xe	216	-	4	-	4	Xe ₂₁₆	218, 220	217, 219
55	Cs	220	-	4	-	4	Cs ₂₂₀	222, 224	221, 223
56	Ba	224	-	16	-	16	Ba ₂₂₄	225, 226, 227, 228, 229, 230, 231, 232, 233, 234, 235, 236, 237, 238, 239	-
57	La	225	-	1	-	1	La ₂₂₅	-	-
58	Ce	226	-	1	-	1	Ce ₂₂₆	-	-
59	Pr	227	-	1	-	1	Pr ₂₂₇	-	-
60	Nd	228	-	1	-	1	Nd ₂₂₈	-	-
61	Pm	229	-	1	-	1	Pm ₂₂₉	-	-
62	Sm	230	-	1	-	1	Sm ₂₃₀	-	-
63	Eu	231	-	1	-	1	Eu ₂₃₁	-	-
64	Gd	232	-	1	-	1	Gd ₂₃₂	-	-
65	Tb	233	-	1	-	1	Tb ₂₃₃	-	-
66	Dy	234	-	1	-	1	Dy ₂₃₄	-	-
67	Ho	235	-	1	-	1	Ho ₂₃₅	-	-

68	Er	236	-	1	-	1	Er ₂₃₆	-	-
69	Tm	237	-	1	-	1	Tm ₂₃₇	-	-
70	Yb	238	-	1	-	1	Yb ₂₃₈	-	-
71	Lu	240	-	16	-	16	Lu ₂₄₀	242, 244, 248, 252, 256, 260, 264, 268	241, 243, 247, 251, 255, 259, 263, 267
72	Hf	244	-	2	-	2	Hf ₂₄₄	246	245
73	Ta	248	-	2	-	2	Ta ₂₄₈	250	249
74	W	252	-	2	-	2	W ₂₅₂	254	253
75	Re	256	-	2	-	2	Re ₂₅₆	258	257
76	Os	260	-	2	-	2	Os ₂₆₀	262	261
77	Ir	264	-	2	-	2	Ir ₂₆₄	266	265
78	Pt	268	-	2	-	2	Pt ₂₆₈	270	269
79	Au	272	-	4	-	4	Au ₂₇₂	274, 276	273, 275
80	Hg	276	-	4	-	4	Hg ₂₇₆	278, 280	277, 279
81	Tl	280	-	4	-	4	Tl ₂₈₀	282, 284	281, 283
82	Pb	284	-	4	-	4	Pb ₂₈₄	286, 288	285, 287
83	Bi	288	-	4	-	4	Bi ₂₈₈	290	289
84	Po	292	-	4	-	4	Po ₂₈₂	294, 296	293, 295
85	At	296	-	4	-	4	At ₂₉₆	298, 300	297, 299
86	Rn	300	-	4	-	4	Rn ₃₀₀	302, 304	301, 303
87	Fr	304	-	4	-	4	Fr ₃₀₄	306, 308	305, 307
88	Ra	308	-	4	-	4	Ra ₃₀₈	310, 312	309, 311
89	Ac	309	-	1	-	1	Ac ₃₀₉	-	-
90	Th	310	-	1	-	1	Th ₃₁₀	-	-
91	Pa	311	-	1	-	1	Pa ₃₁₁	-	-
92	U	312	-	15	-	15	U ₃₁₂	314, 316, 318, 320, 322, 324, 326	313, 315, 317, 319, 321, 323, 325, 327
93	Np	313	-	1	-	1	Np ₃₁₃	-	-
94	Pu	314	-	1	-	1	Pu ₃₁₄	-	-
95	Am	315	-	1	-	1	Am ₃₁₅	-	-
96	Cm	316	-	1	-	1	Cm ₃₁₆	-	-
97	Bk	317	-	1	-	1	Bk ₃₁₇	-	-
98	Cf	318	-	1	-	1	Cf ₃₁₈	-	-
99	Es	319	-	1	-	1			
100	Fm	320	-	1	-	1			
101	Md	321	-	1	-	1			
102	No	322	-	1	-	1			
103	Lr	323	-	1	-	1			
104	Ns	324	-	1	-	1			
105	Ku	325	-	1	-	1			
106		326	-	1	-	1			
107		327	-	1	-	1			



APPENDIX 4

«Formation of chemical elements»

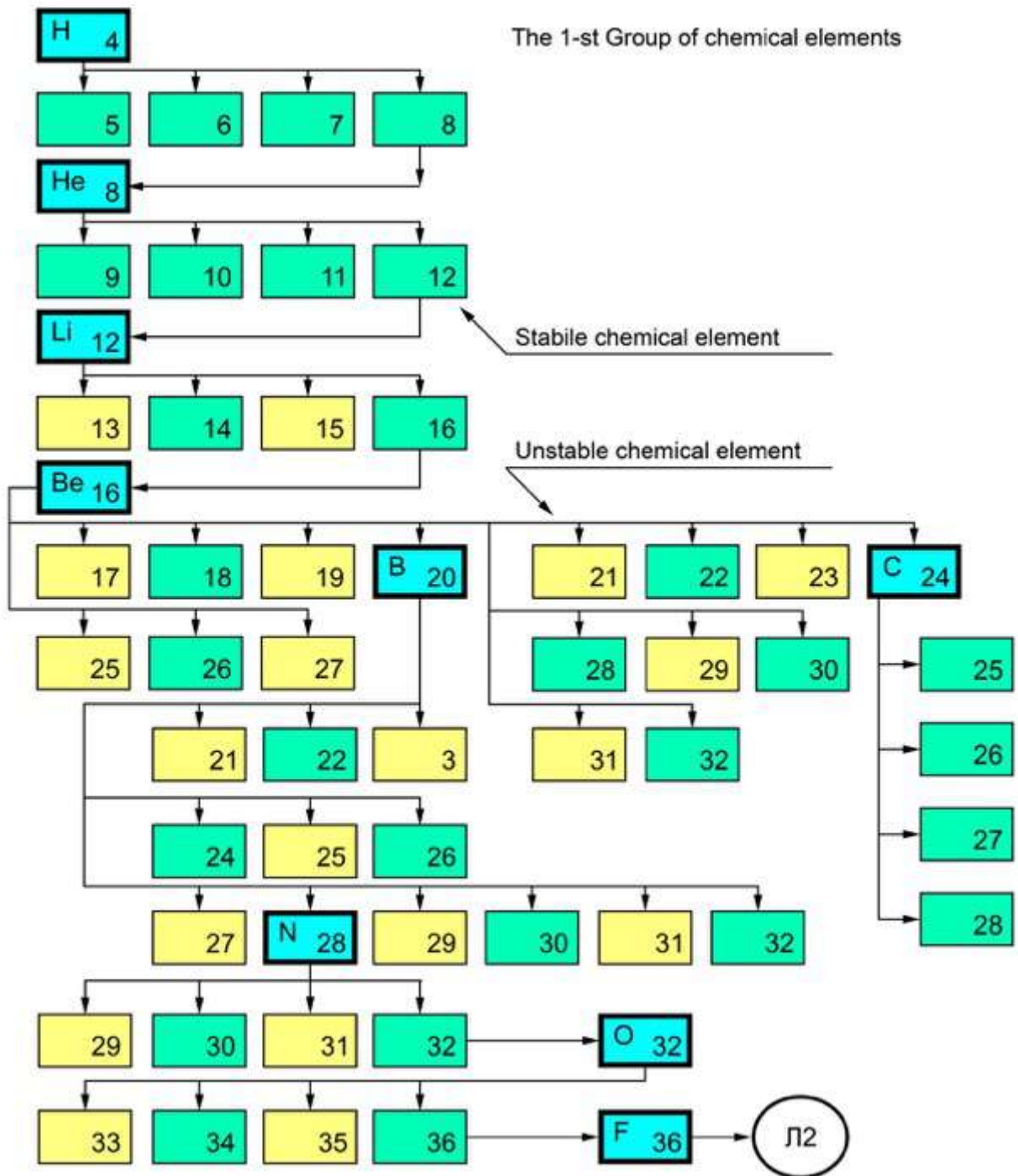

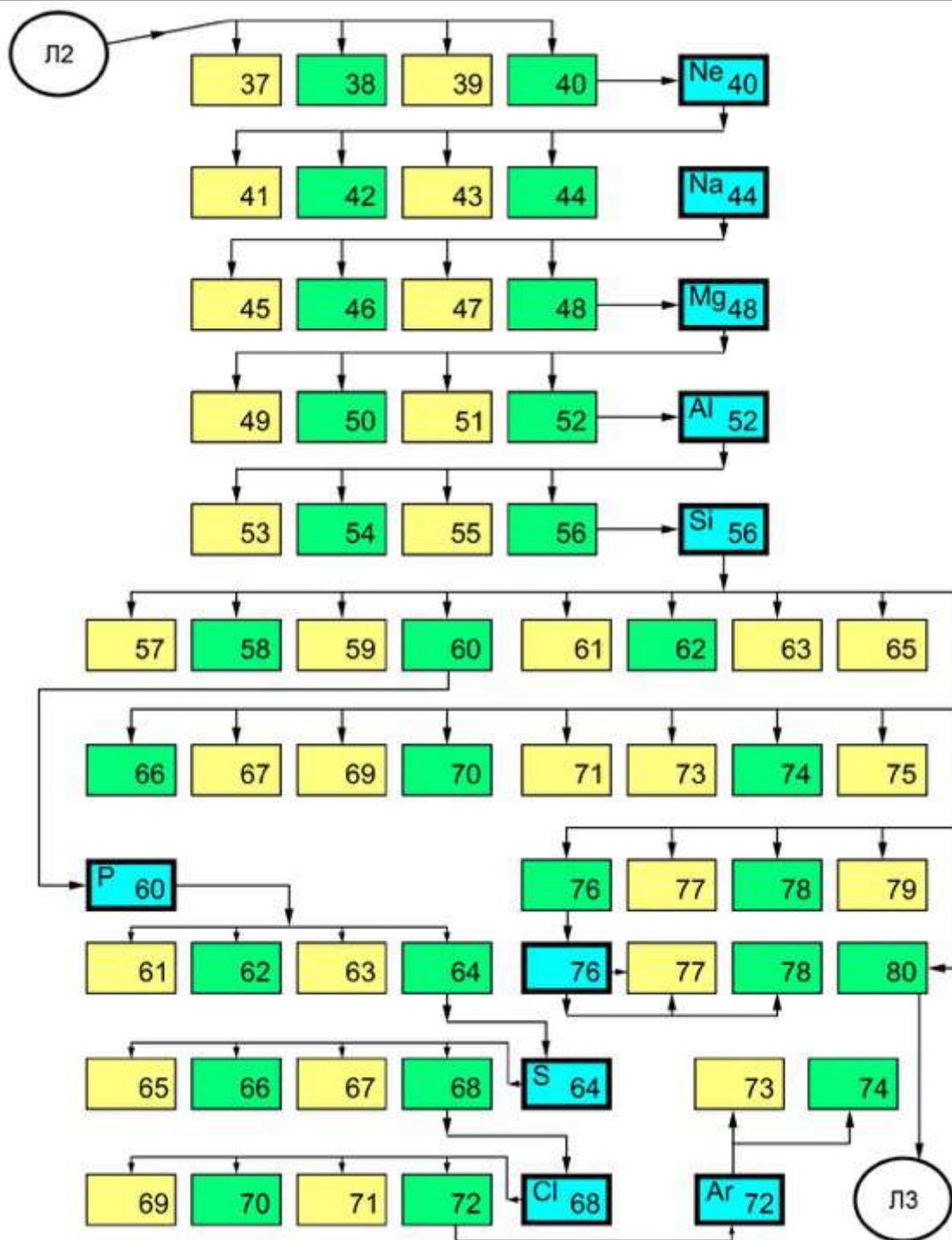

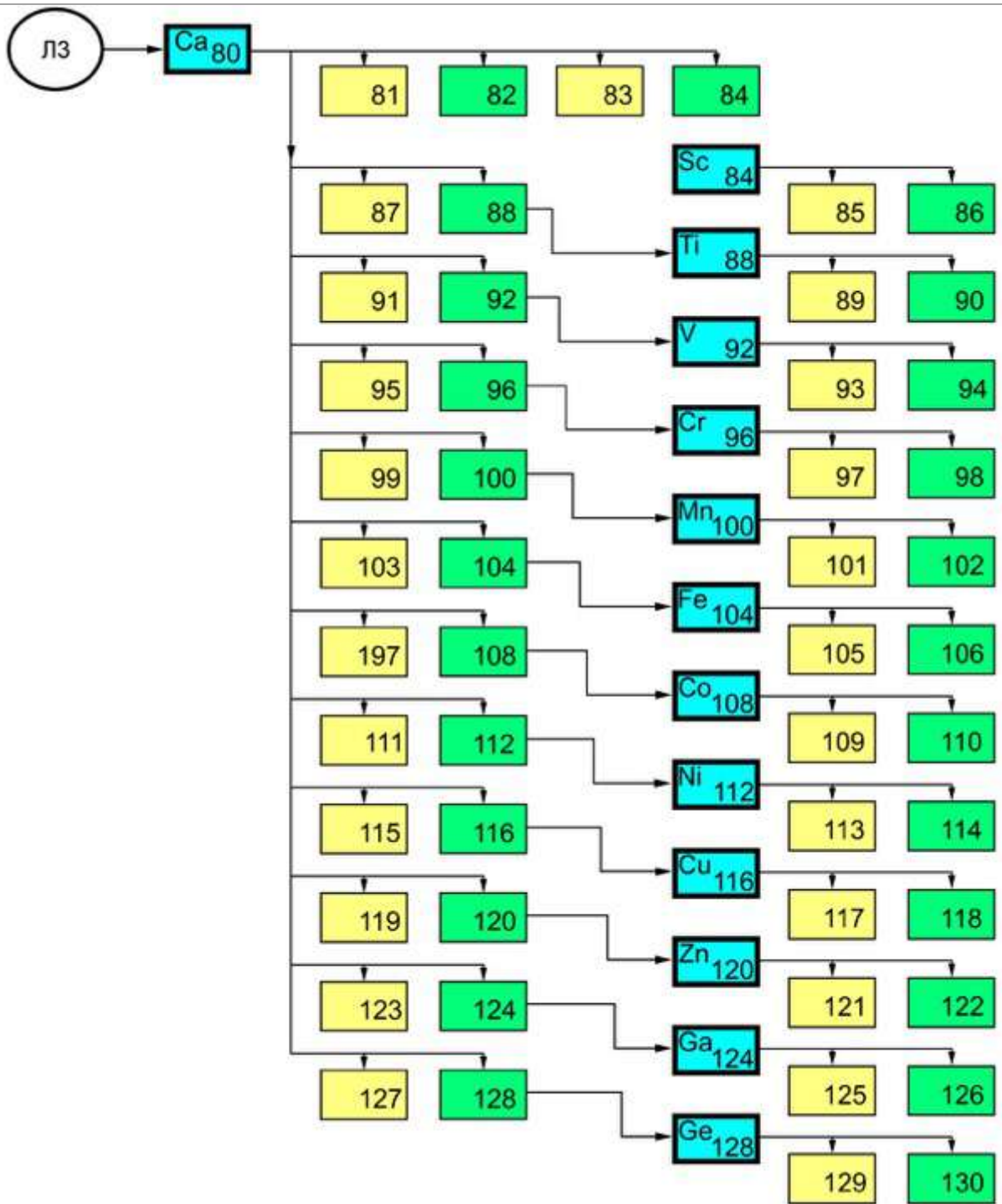

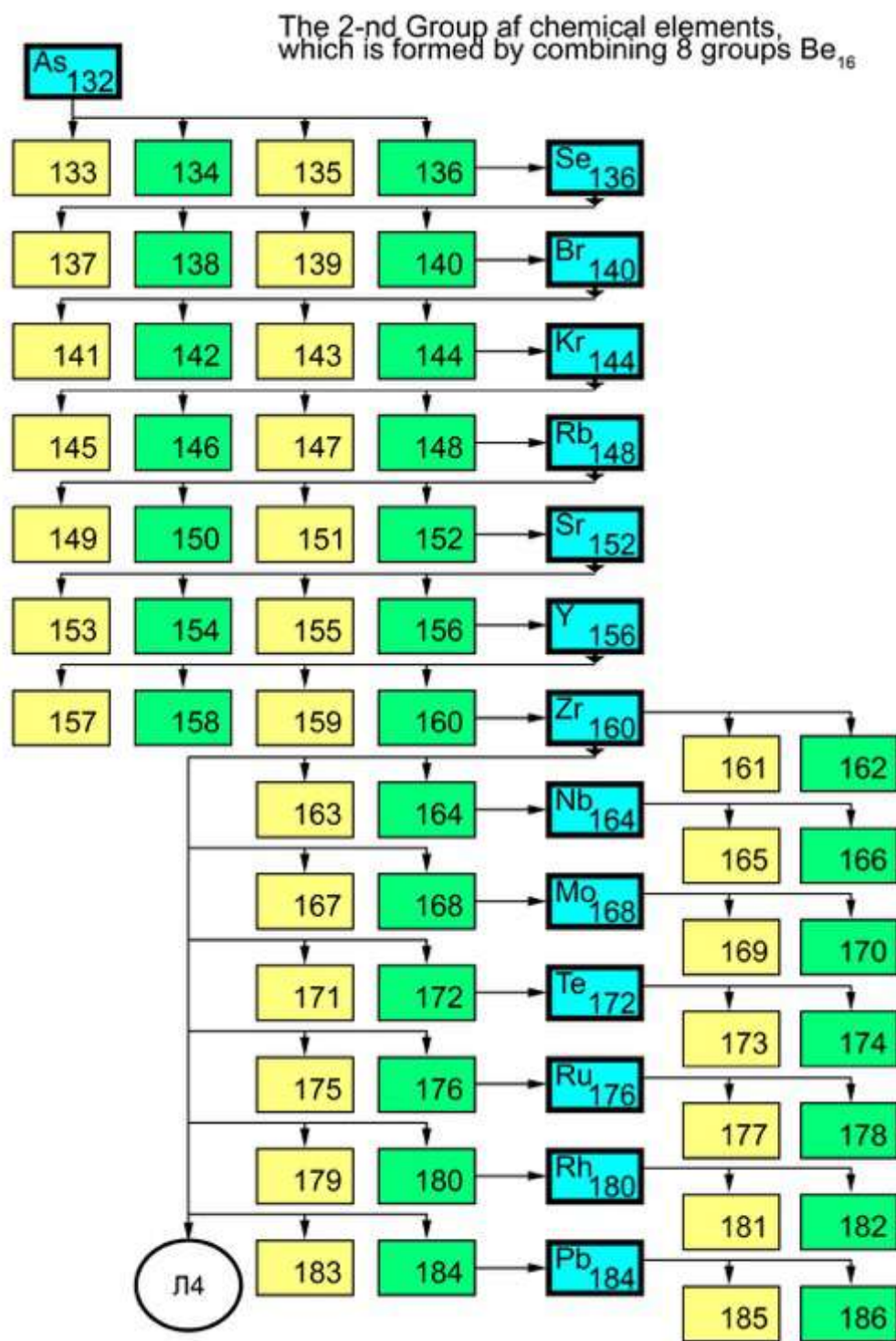

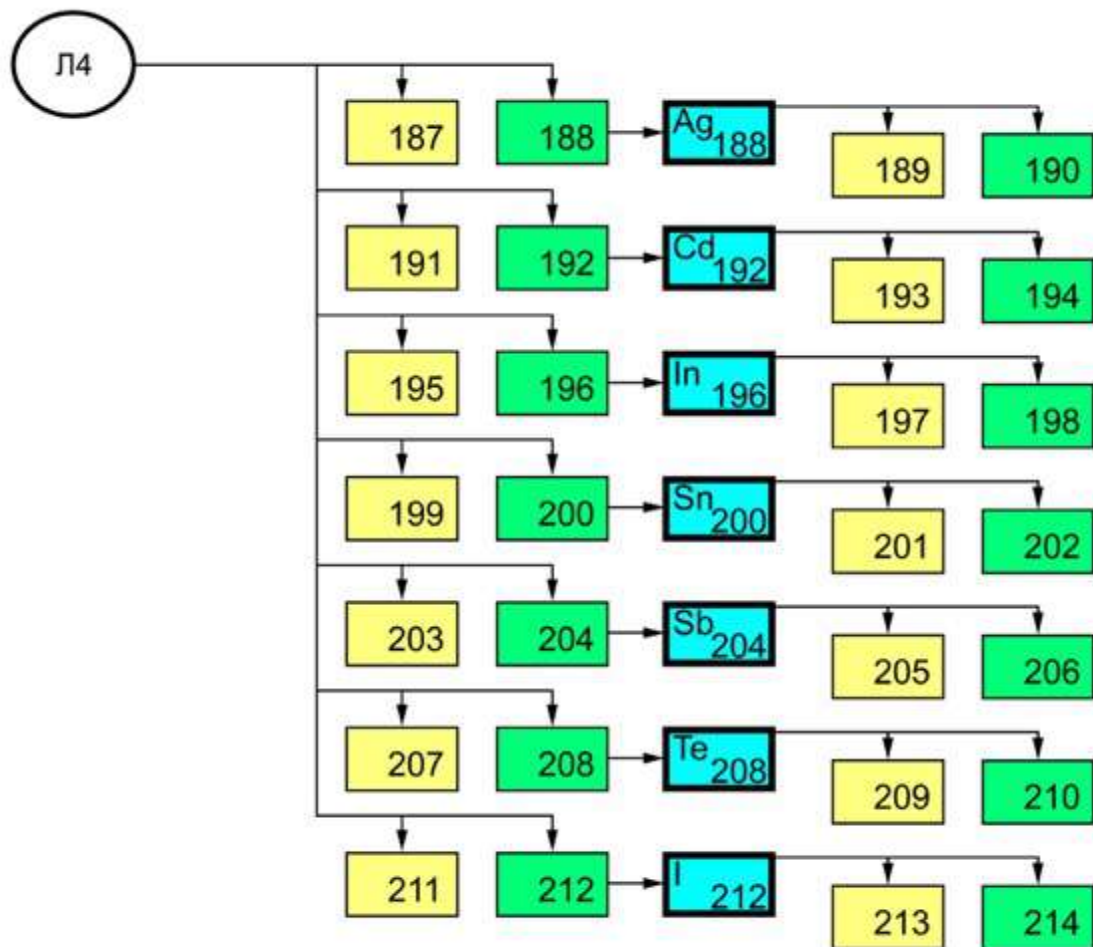

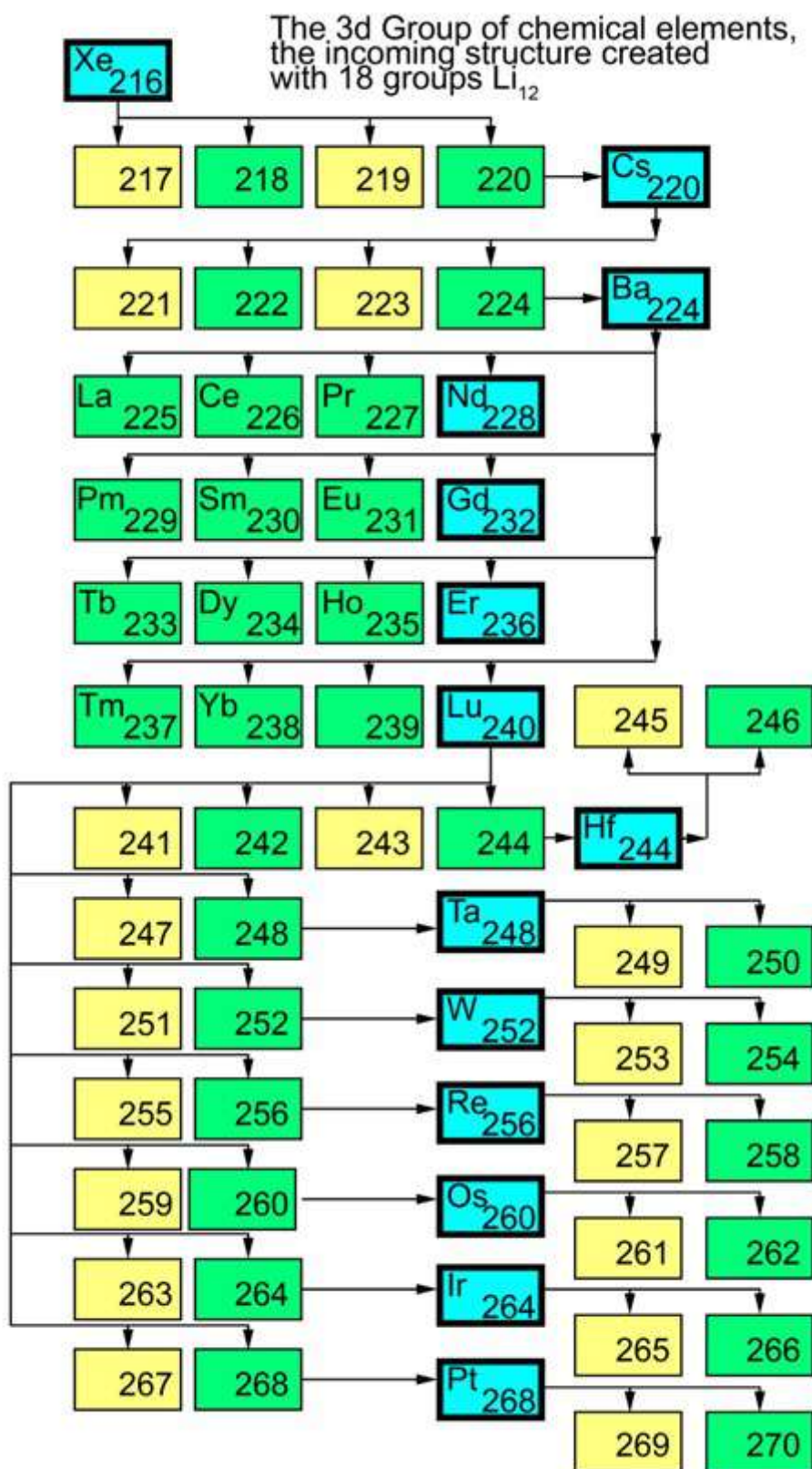

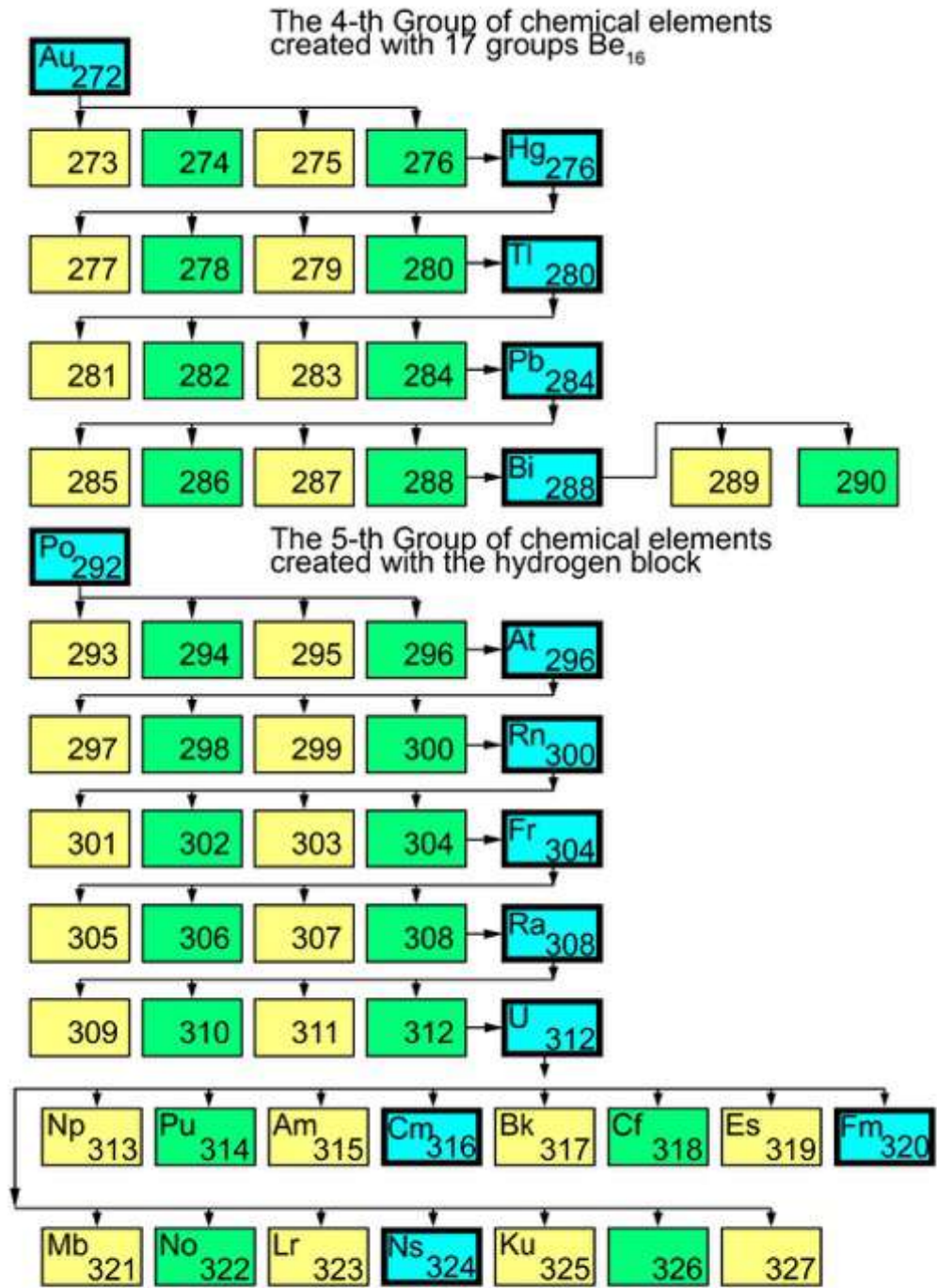

Chapter 8. Hearing and listening

Do not place trust in what you have heard, do not place trust in the traditions passed from generation to generation. Do not place trust in anything if it is a rumor or majority opinion. Do not place trust in the pronouncement of the old sage just because he has an authority. Do not place trust in your guesswork and in what you think is true, what you are used to. Do not place trust in the naked authority of your teachers and elders. After observation and analysis, when it is consistent with reason and contributes to the good and benefits of one and each, then accept it, live in line with it.

Gautama Buddha
2400 years ago

Everything that can be currently attributed to the concept of "Mind" including the whole of the gained knowledge about the world around and the existing feedback with it – is formed and presented by the old Control System, its complexes and objects. Therefore, everything that has been accepted to be "scientifically" attributed to objective reality and called by this word should be perceived and realized as a conditional object-programmed reality (formed by the control objects). This means that the true world is entirely different, fundamentally different from that presented to us and given through the objects and complexes of the Control System.

One can hardly doubt today that since our comprehending the real world is very little, then our understanding its nature, its boundaries, and goals is also negligible. Working in separate areas of knowledge, we had neither the opportunity nor the need to comprehend the whole of it, since no access was given to us. We were not even prepared to formulate questions which we could answer with the help of the gained knowledge, without even realizing their significance among other previously gained knowledge.

There is no doubt that in the construction of the magnificent building of human thought, **PEOPLE WERE WORKERS**, but **THEY WERE NOT ARCHITECTS**. It was concealed from them what exactly they «were building», and why it was being built and where the end of the construction

was, and up to now it cannot be explained intelligibly. Not to mention involuntary errors in attempts to interpret it. This situation is unacceptable and unpleasant, because any work, the purpose and result of which are not visible, is wearisome and has no prospects.

I just state what happened and is happening; the same did Nicolai Levashov in his books, but from a different perspective. Some errors unavoidable under such conditions of activity can be very serious. The builders can deviate from the plan **THAT THEY CAN NOT SEE**, and instead of the necessary they will build the unnecessary – this is objective concerning both the retrospective and the present. All unnecessary will either have to be left unfinished or destroyed. It may also happen that the "builders" themselves cannot come to an agreement with each other in relation to the plan: for example, while some care about the height and beauty of the building, others find such a structure fragile and inconvenient. As a result, both can go on building for the opposite purposes. Something like this is already happening these days, and the participants in these processes are beginning to realize that this should not happen – unfortunately, without seeing the point of the ongoing. For all that, the information received from those who already allegedly understand the situation (at least in the first approximation), as well as the information received from the Internet dump, cannot be a guide to any constructive actions. Basically, such "understanding" only aggravates the situation. I want to break this vicious circle with my books; I want to suggest some expedient actions in the current situation. With all this, everyone has a choice whether to accept or not to accept the suggestion, finding a lot of reasons for that.

When comprehending the ongoing events one can still rely on science and philosophy – with some reservations. Since we already know what modern science is, it is better to call it **KNOWLEDGE OF REALITIES** of the modern world under the present conditions. We will continue to call philosophy traditionally – a special form of the world cognition, developing the system for describing this world with the most general characteristics, maximum generalizing concepts and fundamental principles of the reality (being) manifestation and cognition, as well as Man in his relationship with the world.

In fact, one should realize that any mental splitting of the single concept of the Truth into knowledge and philosophy is detrimental and complementary in itself. Nevertheless, such splitting is necessary for the purpose of describing the very experience of approaching the Truth.

Without going into the discourse on this subject, I only note that ***where everything is doubtful today (I want to emphasize this), it is difficult to say something certain for all times.*** Instead of going towards common goals together, cognition and philosophy go on developing separately, condemning each other. In this separation there lies the inability of the modern worldview to **GIVE A TRUE ASSESSMENT** of what is happening before our eyes.

No matter how reliable is the knowledge that makes up the content of both areas (cognition and philosophy), the old truth is no less true that there cannot be two equally valid statements about one thing. And if there is no unity of cognition, then there can be no confidence in its results, and indeed, there can be no confidence in anything.

Splitting of our gnosiological abilities generates skepticism in itself, because in the process of mental activity it is necessary to initiate any number of questions for yourself relating to the subject of your judgment. It is in this way that you energetically activate the previously concealed functions of your Brain. You do not train IT (these are not muscles) but draw His own attention to His own condition. Another one ***"will not be given until this one gains the necessary activity and fulfills His capabilities"***. So, the most reasonable position in this situation is to wait ***until the dispute is resolved, or, having taken part in it, try to expedite its resolution.***

The subject of our activity should not be this made up discourse between science and philosophy, but the review of the certain aspects (branches) people have worked on over up to now. The desire to achieve this goal **CANNOT BE BUT FRUITFUL**. It is impossible to make such a review outside the limits of cognition and philosophy, since with these two approaches the methodology of access to everything that has been so far comprehended by the human mind is exhausted. Obviously, there must be a mediator between them, a certain key to comprehension and cognition, subjectively and (as much as possible) objectively indisputable, which cannot be subjected to any doubt upon the ways of comprehending nature, boundaries and the structure of everything being observed. **THIS IS UNDERSTANDING.**

And in fact, leaving aside the dispute that separates science and philosophy, we will have to agree that, whatever the activity of the Mind, it is always essentially a process of comprehension and, there is nothing else to be its goal. And this "homespun truth", however simple it may be, brings us

to a number of conclusions, using which, without touching either science or philosophy, we can determine what the first and the second should strive for. **AND EXACTLY – TO COMPREHENSION.**



Everything that fits into the themes and problems of science and philosophy, already proceeds from the mere need for understanding, and therefore is represented by its forms, classes, levels and subspecies. **Comprehension** is not only more urgent and convincing than science and philosophy, but also more extensive. The forms and cells left unsubstituted (as in the table of chemical elements) indicate the heights and the goals Man has not yet reached and, therefore, what remains for him to be fulfilled.

The idea of comprehension does not mean any knowledge that can become contents, but only the existing knowledge. Therefore, the deduction will be a series of truths of formal significance. They constitute **the definition of science**, distinguishing it from a number of all other areas of human creativity and strictly establishing its outside limits, **the doctrine of science structure**, that is, of those inner forms of science, the fulfillment of which should become the content of its future development, and **the doctrine of its attitude to the nature of man and to his life, and his will to life**. In this sense **Comprehension** becomes the central organ of the Mind. In future, we will not confine ourselves to one formal side of the conclusion, but we will add to it a lot concerning the content itself. It is by specifying the forms the science is compiled from, each time we will either establish the truths fitting into these forms or indicate the ways where the truths can be found.

8.1. What was in the beginning...?

"In the beginning was the Word, and the Word was with God, and the Word was God. The same was in the beginning with

God. All things were made by him; and without him was not any thing made that was made". (Saint John, 1,1-3)

How important are the words by means of which we communicate? Do we ever think of the meaning of words in our lives?

We express our thoughts by means of words. What talk about what crosses our mind. Our Mind is the "organ" of thought; it is similar to both the receiver that "catches" and the transmitter that radiates thoughts. In words, we express the point of the subject itself. We fill words with the depth of our inner feelings. In words, we kind of radiate our thoughts both to the interlocutor(s) and to the Universe.

Each of us expresses his thoughts in different words, trying to convey the meaning. When our thoughts are filled with emotions and expressed by feelings, they leave their imprint on the words, sometimes distorting their meaning, because emotions are a stupor of the Mind.

There is a saying: ***"Do not throw away the words"***. The word pronounced becomes mandatory and, taking shape, it is transformed into our reality. Words are all-powerful, they carry the form and the image of what was said, filled with the meaning, if you understand that each letter of the alphabet has a certain meaning and expresses something. "...the letter of the holy scripture is precious, because the Divine thought is expressed in it. But he who does not grasp this thought, for him it will remain a blank sound, sometimes even harmful", said the apostles.

What does the word "**God**" include?

The fact that ***"in the beginning was the Word... and the word was God"***, the most ancient sources say. The biblical version is more widely known. The Vedas also mention that "In the beginning was Prajapati (that is, God the Absolute), in which was Vak – the Word, creating vibration, generating Light and Sound." The Koran says: "The first command was: "Be" and "has become". The Vedanta⁸⁹, like the Bible, says that in the beginning was the Word, and the Light came later. All the prophets, the great initiators, gave the first place to the sound in the process of Creation. What is the meaning of the words by means of which we communicate? Do we ever think of the meaning of words in our lives? What does the word «God" include? The old Russian spelling is БОГЪ. It is **an abbreviation: БО – Gods; Г-**

⁸⁹ Vedanta (वेदान्त, vedānta) – one of the six orthodox schools (darshan) in the philosophy of Hinduism.

speak; Ъ – create. It means – the thought manifests itself through the word; or – the word created. That is **MANIFESTATION OF THE NON-MATERIAL WORLD IN THE MATERIAL ONE.**

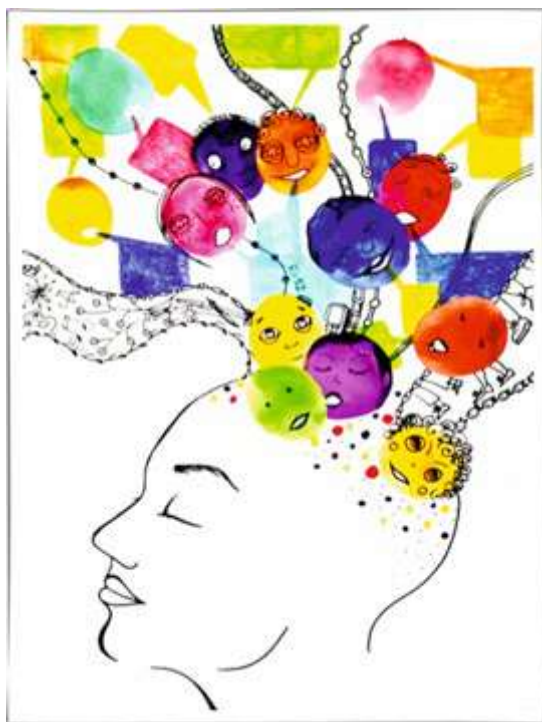

At the level of words, we communicate in the material world, and at the level of thought, images – in the world lying beyond material one, non-material. The images of letters in the word БОГЪ (God) express an indefinite quantity, a superior form that prevails over something. There is a concept, and this prevails over it. Information is transmitted from the emitter (mouth) – the flow of sound information (speech) – receiver (ears). It is an action taking place under a certain control, the process of creation, an unfinished act that is still going on.

Combining the images together, we get: "superior, that is, omnipotent", which is separated from the earthly, having cognized the dimensionality of space, manifested in our World and transmitting the information approved and being accomplished for some action that takes place under certain control in order to continue to exist. This is how the "work" of the Control System Complexes can be described verbally when lining a solution to a particular problem within the framework of the old (Ebr) system.

Our ancestors called Gods those people who could perceive information (knowledge) from other Worlds (or rather, the information of the Control System Complexes that all other people were not able to perceive), and they interpreted it to other people in the form of thought-images. This meant – interpretation of the thought through the word, that is, Man who reached the level of Creation, for whom the world lying beyond the material one was revealed. The world, the limit of which is determined only by the level of the brain development. A man could become God only if he gained the knowledge of Gods (knowledge of perfect people, people with a highly developed Brain) and an open mind that manifested his abilities. Only after that He could manifest Himself in different realities or dimensions of the space. Then He became Almighty, and He was called God. He became

Almighty because **EVERYTHING WAS POSSIBLE** for Him. Possessing knowledge, he could control the universe without coming in the way of the laws of harmony, which gave the right to be the Creator. It is for this that the Earth was created, as an instrument for making Creators for the Universe.

This is confirmed by what Nicolai Levashov first told us about, and in fact, he showed us with his whole life, his works and deeds: through his example he showed us the Man really living on the Earth who raised to the level of creation – the level of God; and he also demonstrated that was not a fiction or something beyond the world, unattainable and incomprehensible. God in Greek is **TEOS = THEOS = TE-O-C**, which means the Spiritual basis of the existing. The life of man should be dedicated to these aspirations, but not to be consumable used-up things where we have been driven to the last several thousand years.

Man shows his abilities in creation. Creation consists of the ability to receive information (where the Brain genotype is most important) and realization of the obtained into being. The development of being from one sphere to another is called an event. An event is **REFLECTION OF BEING**, a mirror. What you show it, you will see. If you show it a lie, you will see a lie in response.

The beginning of everything **IS THE WORD**. The formula of creation is the Word. The word is a combination of the thought, the image and the sound. When the word takes the form, it is Speech in space, when it becomes visible it is Language. Creation is a link that connects a vivid thought form with the earthly energy of space by the power of sound, bringing to its manifestation in the material world. Language and speech are an information system for coding Man's object-imaginative thinking. All phenomena, things, objects have their names expressed with the help of words. The most important component of Creation is the thought. ***The thought is an image-containing form expressed by the word.*** Through the thought, the form of the image itself is transmitted, which generates the energy movement in the form of the object, which is the reason for its appearance. And finally, the conceived thought form created by Man (if, of course, he is able) manifests itself in the material world. The syllabic meaning of thought is the vitalizing primary force directed to the beginning and end of all creation, that is, all-embracing vitalizing power of the image.

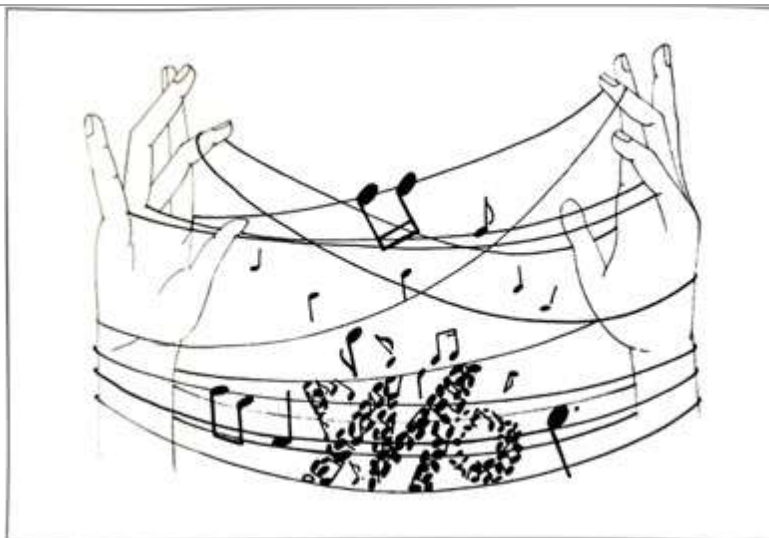

We are capable (even with the Brain partially opened) ***to communicate at a distance, to control phenomena and objects by the power of our thought.***

The second component of Creation is an image. The image is a union of the divided and the distant, that is, heavenly and earthly. We need the Image in order to see the Thought. The image is like a hologram of the thought itself, which then **DISPLAYS IT IN A WORD**. Images are needed in order to have an idea of something, as well as for visual perception. Our brain is "Homeland of images". The Brain is a mosaic of addition, that is, a processor that processes the information obtained in the way intelligible for us. The image is the eyes of the Brain. If Man does not see images, then he is blind. All digital technologies of mass application today first of all are aimed at making people "blind". The mechanism for the image development, a book, is intentionally supplanted by these digital technologies. The organizers and producers do realize that the Image is the result of education. With the thought and image union, an idea of the object or phenomenon is formed. But this undermines the pyramid of the Control System built for millennium, which is collapsing before our eyes, however, still exists in its auto-motor-like reality.

The image is the result of formation of something and it is formed when the Thought is combined with something. Then a question arises –what is that which the Thought combines with? What is the most dominant without which the Thought is just blank space? Of course, it is the Brain and its capabilities (development). Then the image is the combination of the divided (the distant) with the manifestation of the meaning, the essence. Our Brain, if it has at least a minimal tendency for its development, creates the Image which, manifested as the Word, depicts an integral picture of our World. The

word takes shape in the space and becomes visible, creating our reality, that is, earthly life. However – **INFORMATION WAS BEFORE THE SPACE**, energy, matter and all forms of existence that once began to exist. We cannot yet think of what it consisted of, but it is unambiguous: **information precedes any existence, at the same time, being nothing of the existing**. Information is one of the most important properties of the energy primary matter (magnetic and electrical), transmitting (carrying in itself) the world-forming goals of the structural arrangement. Moreover, and I have mentioned it **in book 2** ("Introduction or the desired in realityv), if information is really to replace matter being the very first substance of Cosmos, then we can expect even greater reward... From the modern point of view, the Brain (matter) "gives rise" to thoughts (mental information)... But if the matter is the form of the organized information, then consciousness is no longer as mysterious as it seems to us. Now physicists themselves have started talking about the appearance of the matter as the "form of the primary and organized information" – **INDEED, "IN THE BEGINNING WAS THE WORD!"** In both cases, we are dealing with a virtual world, something similar to the all-generating "global computer network". The word can be considered the highest form of Consciousness of Man, and especially Man, who speaks the Russian language, which is considered the language of all languages. So far, we comprehend the whole world through words, not "being able" to create thought forms, formulating with words **NOT ONLY** thoughts, but even feelings. And if we lack the ability to tell ourselves something, we cease to understand our own "I". Now the EARTH CONTROL SYSTEM (ECS) speaks this language...

Today, the words bear **MAXIMUM SYNERGETICS regarding their meaning, regarding the information laid in them**. As an example, is the Nativity of Christ. It should be understood as the moment of the idea being born (information, as being the essence) through a specific object, i.e., the Spirit (the Brain). Such a Spirit was Jesus (Radomir). It was this way, through the Spirit of Jesus, by the true System the "Information" was presented (then there was no such a concept as theory – a variant of information or the Nature of its structure) about how people should live, what life rules they are to follow, what they were in that world, and all the rest. Over time, all this was coated with plenty of legends (deliberately created), and that is exactly how one of the Control Programs was imposed – the "**Control for the people's existence**".

Thus, **in the beginning was the word and the word was God!** Here the main point is in understanding the terms «information» and

"word"! When it was written about the word, there was no such a concept (term) as «information». **THE WORD IS INFORMATION**. What is primary here – the question is essentially incorrect! Of course, information. IT was when there were no words! Information is primary – because a word, ***first of all, is sounded information and its transmission through the word in "human" perception!*** The information is primary for the world outside, but for Man – information, is expressed by the word for that period. Therefore, it is correct – **THE WORD FROM GOD IS PRIMARY** and the word is **GOD!** (Here we mean the whole control system) – IT says: ***from me – in the word!***

Let me remind you that the first Complex that began to work after the Earth's capture was the Ararat, which formed the grating carrier frequency, and only then the grating of «hearing» was created (***"In the beginning was the word..."***), then sequentially the rest of the gratings were created. ***That's where it came from.*** But before the creation of the first genotype, the ability to receive and transmit conscious information in the form of speech ***was given by objects of type 440.*** In total, they gave **384 "languages"**. ***It took millennia*** to adapt the human Brain to the perception of at least auditory and visual information within certain predetermined energy octaves, to impart controllability to the sound perception functions and pronunciation, and to create logical ideas of images and primary intuitive skills.





















8.2. Nature of reality

Information was earlier than space, energy, matter and all forms of existence, which once began to exist. We cannot imagine what it consisted





















of, but it is unambiguously, **information precedes any existence without being anything of the existing at the same time.**

Did we need God, if the proto-man did not believe in God, but had a worldview? So, the interventionists needed God. And they imposed IT on us – "in the beginning was the word...".

Thus, the word is: a thought + an image + a sound is the form of matter existence. This is the structure of creation, the basis of wisdom, which consisted of one word: **GOD IS THE WORD**. Here "is" as if, manifests itself in the material world, which through the thought and sound acquired the form of existence in the material world. Therefore, the word GOD means those who created images, which through the thought and the sound acquired the form of existence in the material world. We endow thoughts and images with the energy necessary for creation. The Matter is energy in its various manifestations. The sound is the vibration of the energy compaction for its various manifestations in the matter. Therefore, there could be nothing without the Word. According to this formula of creation, all events and human life are formed, created and built. In the Old Russia, images were encrypted in runes. Thus, the runica was a figuratively-holographic letter. **The rune is a sign, symbol, hologram and image of the Worlds of Pravi, of Navi, and Yavi⁹⁰.**

	Vl	У-ДАЛЬ	Путь		Pt	И-НА	Защита
	Au	Ю-ЛЬ	Достаток		K	ФИ-ША	Концентрация
		И-У	Тяжесть			И-ШУ	Лёгкость
	Sn	ДЫ-ДЫ	Дыхание			КА-ША	Целенаправленность
	Pb	МИ-НА	Жертвенность (знак воина)		Al	МУ-РА	Сытость
		Вихрь (принцип антигравитации)			Cu	У-УШ	Любовь
	Md	М-У	Рассеяние		Os	У-ПА	Замок
		ВИ-ТА	Вода			УЛЬ-УЛЬ	Наша Цивилизация
		ШУ-ШУ	Поток		Fe	У-МА	Победа

⁹⁰ The world of Pravi – the world of Gods; the world of NaRi – the world of the dead; the world of Yavi – the world of the living. «the three worlds of the Slavic mythological worldview.

	Ca	У-Ш	Рост		Va	В-ИШ	Ветер
	Cr	ВИ-РА	Веденье			У-М	Ускорение
		М-А	Замедление		W	ДЫ-РА	Огонь
	Pd	И-ЛА	Лёд		Zn	ВА-ТУ	Дезинформация
	Co	МА-РА	Разрушение		Ti	И-ША	Мощность
	Te	И-ЛЬ	Восстановитель		Mg	УМ-БА	Радость
		ВА-РА	Вечность		Mo	А-ЛЬ	Равновесие
		А-Л	Ноль			И-Щ	Оболочка
		У-ЛЯ	Ясно			ТУ-ТУ	Пасмурно
		ВА-ВА	Дождь			И-РИ	Ключ
	Ag	И-РА	Помощь				

It defined the meaning of the word and limited access to information of the uninitiated people. The words expressed the image of the divine act of creation, and therefore the Russian language was the word-forming language. Later, through the substitution of concepts, distortion of the original images, through the reduction and distortion of words, other languages came into being. The language expressed a unified system of images, the matrix of meanings as something interconnected single whole. To simplify the language, the figurative RUNES were replaced by a sound (phoneme) alphabet. The Images were replaced with phonemes, and the language became ugly (i. e., without the images). Therefore, the true meaning of the words images is distorted in understanding it and perceived incorrectly.

The name of **Platon A. Lukashevich**, an outstanding Russian scientist, linguist, philologist, ethnographer, writer, historian, mathematician, physicist, chemist, astronomer, was erased from the memory of the people. His books were hidden in the most inaccessible depositories of libraries.

He comprehended the law of formation of all languages of the Nations of the World and the mystery of numbers. It is impossible to grasp the painstaking, titanic work of Platon Lukashevich. Knowing more than 40 languages and dialects, studying and comparing them and world history,

customs, songs, legends, myths of most of the peoples of the World, he came to the conclusion that at the creation of *the World the Human Race had a single universal language* – **ISTOTNY (PRIMARY)**. Over time, for various reasons, other languages were formed from it – **CHAROMUOTNYJ**. (enchanted, lost their original meaning). Until recently, *Sergey Danilov*⁹¹, who had a deep knowledge of this issue, gave lectures on this subject. All enchanted languages were formed according to the same and invariable laws, within the framework of the interventionist Program for creating brain genotypes. The images of the ancient primordial language are collectively preserved in all Slavic languages. The peoples who preserved them began to be called: **SLAVS = SLOVS** – masters of the word. But then, for more than five millennia, the original language in Russia continuously lost its properties. And now the Slavic language that we have is only an echo of the primary language.



The letters "Ъ", **Ять**, **Ерь**, **Юсь** were removed from the Russian Language, which destroyed the musical and tonic grammar of the language, and it lost its musical color. All the nasal, guttural, sibilant were removed. It was these sounds that, when pronouncing, activated the work of the Brain, «opened» in it the necessary zones that contribute to the development of clairvoyance, clairaudience. Thanks to the combination of certain letters, our body was restored under the «control» of the Brain. For example, nasal sounds open the "Eustachian tubes" in the brain, giving clairaudience. The images are formed in the Brain thanks to the frequency sound codes, which have their own matrix – a letter that has its own image; two letters, when combined, give a new image, etc. And in the same way the integrity of the syllable was lost in many words. Now the "main secret" of the Ancient

⁹¹ Sergey A. Danilov , a military man, lawyer, and public figure. Free Cossack, a reserve officer, Explorer of deep meanings "ancient Slavic" and "Holy Russian" languages, an active supporter of the revival of the old tribal social structure, and Veche government Power. Died 20.12.2016. Sergey Danilov's Funeral was held on December 22 in his native village of Tishanskaya.

Language has already been revealed and it has been established that the Old Russian **LANGUAGE WAS SY-LLA-BIC**. Each sign was a syllable. The words of the ancient language were written and read in one line without separation, in syllables from left to right and vice versa. Each Word had several innermost meanings. Thus, the code or key to the secrets and hidden information is read by the ancient Slavic words in syllables, inside and out. Sergey Danilov told his listeners in detail about all this and, – both publicly and in our talks with him. It was from understanding this that through reforms we so diligently for thousands of years have been led away from the letters that have the highest vibration. The figurative construction of thought-forms is a sequential assembly of many words, for example, two letters **Ѧ** (Ѧта), **Ѧ** (Ѧта). In the words, where they were used, they "bombarded" the receptors of the Brain neurons and harmonized their work. Not only logic was turned on, but also images. And then – a distinction occurred – whether you need the information, or you do not.

Our ancestors primary speech was informatively dense and fast. Nicolai Levashov always emphasized at his meetings that he «worked» at very high speeds. Our modern language is simplified, we were transferred to a phonetic way of receiving information, there is no imaginative thinking, the Brain's work processes are inhibited and correspond to the created Brain genotypes, whether we like it or not. Therefore, one of the points in the development of the Brain is its ability to create a holographic image of an object that is easy for understanding. The process of creating a holographic copy by the Brain was considered by Levashov in the book "***The Spirit and the Mind***".

What is speech as a physical process? It should not be habitually understood only such a conditional process, which is connected in some simplified, indefinite way with the use by the people, «invented» by them combined sound images, gutturally pronounced sound forms and techniques, using which some generally accepted and generally recognized simple or complex images of the surrounding reality about the objects some kind of automatically transmitted and perceived; their interactions and events, reflecting or somehow connected with the surrounding reality being and people in this environment, together with all their actions and interactions; its generally accepted understanding or description of something in judgments with the help of speech not voiced by people (not sounded judgments, that is, not aloud). One way or another, speech is **ALREADY DEVELOPED AND UNDERSTOOD** standard images

(forms) of simple or complex elements of the people's Consciousness that are presented through permanent patterns of the Human Brain's connecting neurons. When we reason "intra-ourselves" (without voicing the results of our reasoning), we still use the generally accepted abbreviation for the same form of speech, with all the same techniques or methods known to us, only in the non-sonorous "mode". Therefore, it doesn't matter whether we voice" our opinion or not, write it down or read, but we reason using the same speech as an indispensable tool for "transmitting" part of information through the gifted to us ability *of "talking to each other"* or some imaginary interlocutor. True, "this gift" is not always applied correctly, and in most people it is in a sleeping state today.

In order to have a certain "speech potential" or a comprehensively developed universal set of the speech process "behavior" with its voiced or non-voiced application variant, each individual in the process of his (her) cognition must inevitably "develop" (form, gain through learning and training) a certain number of the typical Brain neurons connecting schemes, which, through its functions, are responsible for speech as such and representing a constructive holographic model of the subject of its speech description, as physical body. He (she) should learn (train) to represent and describe all kinds of observable or imaginable physical processes at the moment of the present, past and future of all interactions of this body with other bodies (observed or imagined) in the world of the surrounding visible or imagined Being; transmit this information using the "the behavior speech potential", which is accepted and understood by other individuals, or be able to represent everything indicated in written or graphic information from with the help of the accepted conventional speech symbols and other figurative designations and visual constructive techniques. Thus, the speech ability granted to us is an indispensable "participant" in the Consciousness elements formation, as well as other various schemes of the Brain neurons connections. Of no little importance is the fact that since 2007, the Control System **HAS BEEN TRANSMITTING AND RECEIVING INFORMATION ONLY IN THE RUSSIAN LANGUAGE**, it no longer accepts texts (complaints, requests, etc.) in other languages - only in the (correct) Russian language. The English, Arabic and others languages are for the bazaar (market) relations. By the way, the Ukrainian language is not even in this list. To understand the basics of the language formation, one can refer to the so-called "*Morozov Square*", (N. Morozov, Christ, vol. 3.) It should be taken into account that the pronunciation, especially the Russian letter

«r», must be correct, the text without mooring, interjections and aspirates. These are recommendations from A. M. Khatybov, which are worth agreeing.

8.3. Logarithms of the number of vibrations

We are interested not only in phonetics⁹², going into detail and perception of sound and pronunciation, but also the sounds and music of human speech. Let us turn directly to the original source – the unique work



of N. A. Morozov "Christ", to his third book, "God and the Word", and, in particular, to Chapter 2: "Music of Speech. A Human Word in Natural Science". Let me remind you of the words of Nikolai A. Morozov about why all his books have a common name "Christ": "This research work, to which I gave a common name "Christ" (understanding this word not only in the Gospel meaning, but in its Greek meaning – "dedicated to secrets of the occult sciences") – was conceived by me in the solitude of Alekseevsky ravelin and in the first years of imprisonment in the Shlisselburg fortress , after they began to give me books for reading with

exclusively religious content. One common heading "Christ" does not limit my subject to one gospel master of the occult sciences. This Greek word just means – consecrated to the highest degree of the ancient, self-contained corporation of scientists who considered their science to be granted to them by God the Father himself and who kept their knowledge in strict secrecy from outsiders. Its literal meaning is an anointed sovereign (Christ), since the initiation to the highest degree of the master was then accompanied by oiling his head with aromatic vegetable oil with a small brush, or by pouring this oil from a jug onto the crown of the initiate. I understand the word "Christ" in my book in a broad sense, and therefore, **Moses, and Aron, Samuel, and Elijah** are the same christs as the Gospel one, regardless of whether they are all mythical or their biblical and gospel biographies are

⁹² **Phonetics** (Greek "φωνηεντικός" sound "from φωνή" sound) is a section of linguistics that studies the sounds of speech and the sound structure of the language (syllables, sound combinations, patterns of connecting sounds into a speech chain).

primitive science fiction novels from the life of real personalities. Before proceeding to the analysis of monotheism mystical theology, I had to write, as I put it, a linguistic interlude, to which the entire prologue of this book of Christ is devoted, and to show, first of all, the artificiality of the Latin, ancient Hebrew and Sanskrit languages, in which the main of the mentioned apperceptions⁹³ are written".

Can we call the limited sounds of our speech and the corresponding written symbols of literature as enzymes of human thought and science? It is difficult to make up a more suitable name for them. Both in the field of physiological processes, comparatively insignificant and limited in number of their molecule's enzymes like pepsin, diastases, and secretions of various glands play the main transformative role, and these few signs and sounds imperceptibly process our entire social and personal life. Without knowing their role in the creation of our psyche, one cannot consciously consider the history of human culture.

Inevitably, in addition to astronomical, geophysical, and other prologues, it was necessary to introduce into it this linguistic⁹⁴ interlude, which can no longer be called an introduction to any of the departments because linguistic considerations indirectly led my way in all previous conclusions and will continue to guide them further.

N. Morozov in his works showed for those who want to understand this crucial issue, the need to know anatomy, especially the main organ of any psyche – the brain in general, in order to understand why, in addition to the real history of mankind and its mother nature there appeared and developed in their minds their illusory stories, and why, besides **REAL IDEAS OF PEOPLE** about themselves and about the elemental and organic modern world that surrounds them, they still develop **ILLUSIONARY IDEAS**, often making them take the wrong way, to their sorrow, while building up their lives.

In the prologue of the book, N. Morozov tells us how much necessary it is for a truly scientific study of ancient human life to have sufficient knowledge of comparative linguistics and ***the science of the human speech sounds***, which exists only in the minds of a few linguists and is unfamiliar at all to not only educated people, but even specialists in related

⁹³ **Apperception** (lat. Ad – to and lat. Perceptio – perception) is a process as a result of which the elements of consciousness become clear and distinct.

⁹⁴ **Linguistics** (from lat. Lingua – language), linguistics, – the science that studies languages.

fields, such as sociology and general history of human life on the earth. Many of non-linguists have not even heard of anthropophonics⁹⁵. It is not taught in any of the general educational institutions, and yet it is extremely important both as a general educational subject and as a primary means for restoring the past history of humanity, the genuine history, and in this sense its general outline is necessary for understanding this chapter.

Giving some methods for the linguistic research of primary sources (by means of linguistic spectra and phonetic composition of languages), I do not touch on the ordinary modern paleography⁹⁶ here, since I consider it the least reliable means, due to the fact that the previous character of writing was preserved in remote provinces long after in the capitals they switched to a new handwriting. Giving them a natural-scientific treatment, it was inevitable that more than once it was necessary to resort to comparative linguistics, which, in turn, becomes serious science only in connection with anthropophonics and remains without it, as if it were the building without strong cement. This is especially important in order to find out how trustworthy is the traditionally recited pronunciation of words from our ancestors that **VIBRATED THE ATMOSPHERE** of the globe more than a thousand years ago, because we have to draw conclusions about the events that passed so long ago by the sounds relating to those passed facts. But first, let's consider what anthropophonics is.

The words of every speech *are wave-like shaking of the air*. Even in the beginning, our ancestors still could not know either acoustics or optics. Here, for example, the biblical book "Genesis", according to which both physics and cosmogony were studied until the beginning of the 20th century. In its first chapter, each word of "father of gods" receives a material "casing", as in the gospels, showing the same era of the mental evolution of its authors. Father of gods was only to say: "Let there be light! ", And the light appeared looking like "transparent air", that is, such medium through which, like tentacles, invisible and imperceptible flows of our soul penetrate. After leaving our head through the eyes and reaching the subject in question, they again return through the same eyes to our soul in order to tell her what they felt outside of us. *The word "light" turned into light as soon as it was*

⁹⁵ **Anthropophonics** – (Greek, from Anthropos – human, and phone – sound), the physiology of sounds of human speech

⁹⁶ **Paleography** is historical and philological science that studies the development of writing, and also allows determining the authorship, time and place of creation of the literary monument.

spoken by God. Now various rays of light for us are only one series from a huge series of invisible series of different wave-like vibrations of the interstellar medium, penetrating all the objects except their atoms. They come from the atomic vibrations of all physical bodies and produce both gravity and electromagnetic attraction and repulsion of objects exposed to them. **The diverse sounds that are heard and not heard by us are now only a few series for us from a huge number of different systems of wave-like movements of the Earth's atmosphere.** They come from sounding bodies and are transmitted by the mixture of nitrogen, oxygen and several other substances surrounding us, dissolved in the interstellar medium adjacent to the globe (just like salt or sugar dissolve in water), and do not fly away only due to their attraction by the globe. Why do we hear **ONLY SEVERAL SERIES** out of a great number of vibrations that are able to be transmitted to our hearing from rhythmically vibrating bodies by our atmosphere? Why is the simultaneity of some of them pleasing to us and seems like a musical chord, while the simultaneity of others seems to be a discord? The first circumstance is explained by the structure of our auditory organ. Sound waves penetrating through the tympanum into the inner channels of our ear go through the second membrane into the cochlea, where the vibrations of the membrane separating it and the interference nodes in the liquid itself, brought into sound movement, enable us to determine the pitch of not only one fundamental tone of the reaching sound, but also a significant number of smaller or larger vibrations, meta-tones that overlap it, the presence of which determines the color of the sound, different in the music of various instruments and in voices of different people, even members of the same family. The action of the membrane in the cochlea is very similar to the action of the strings of a piano. Open the piano and say: "O"... Only those piano strings that are tuned in unison with the metatones of this vowel will give an echo to it, and the piano will echo you like "Oh"... In the same way, when you pronounce any other letter. Our ear cochlea also does the same, and the auditory nerves passing into it transmit it into the gray matter of our brain (and not the ear!), which perceives and imprints them in itself and, when necessary, brings it to the area of our brain where our conscious life is located. The same piano gives



us an explanation why all the octave tones, despite the height difference, seem similar to us, and got the same names: **do, re, mi, fa, sol, la** and **si**, despite the height difference. This is because if you give the string its characteristic fundamental vibration, then it will give by itself, albeit to a weaker degree, the octave vibrations closest to it. Note "na" here will stand apart from its vibration.

So, if at the same time another string sounds an octave higher or lower, then the waves of both sounds harmoniously overlap, amplifying their overtones, and the impression is the same as in poetry from a full line rhyme.

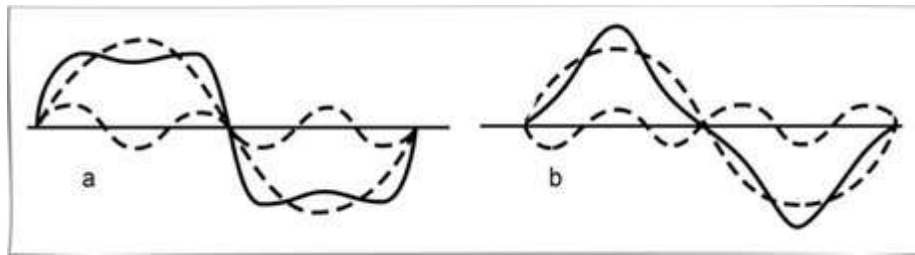

In this figure, there are two results of the transverse waves overlapping (and, at the same time, thickening and rarefying of the longitudinal ones). The black line is the result of overlapping two corresponding dashed sinusoids. In case a) when the beginnings of both are directed according to, and in case b) when the beginnings are opposite.

When there are two or three vibrations of one string on three or four of the other (with sufficient accuracy so that they can spontaneously correct small fractional gains or shortcomings by influencing each other), there takes place something like an interlaced alternation of two or three rhymes, and the impression is nice. And with much greater complexity, there is no spontaneous assimilation of tones and there occurs what we call dissonance or disharmony of sounds, as can be seen in the wavy lines of the next figure.

The first curve is when the vibration frequency of one tuning fork is twice the frequency of another one. The second curve is the same, but not quite accurate. The third – when for one vibration of the second one there are three vibrations of the first one, etc., as shown from the side. In more complex relationships (like 24:25 or 80:81), there is amplifying or fading of sounds, called dissonances.

If we assume, as is customary, that the average human ear perceives only waves above 16 vibrations per second as sound, and not like crackling, then its next octave are **32, 64, 128, 256, 512, 1024, 2048, 4096** vibrations per second, and the last of them will be heard only by a rare ear, but for the ordinary – it is already silence.

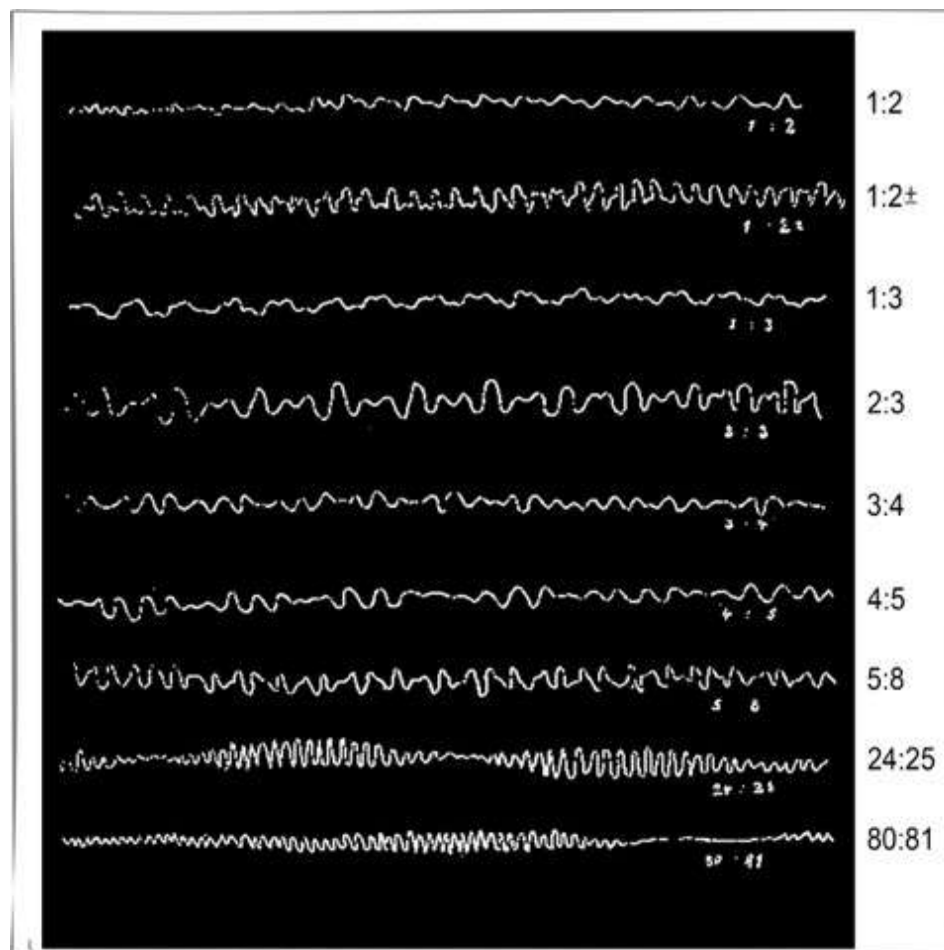

Graphs of musical tones obtained on a sooty plate of two tuning forks

And we see that the gaps between them increase exponentially, while the number of different tones (called musical semi-tones) for a European's ear remains in both the lower and upper octaves only 10 (with flats and sharps), and a rare ear determines the sounds, intermediate between them, called quarter tones, which again brings our hearing organ closer to the piano, in which the tones do not change one into another continuously, but stepwise, by assimilating the intermediate ones with the nearest semitone or with a quarter tone. This means that the tone-discriminating ability of our ear increases as the logarithm of the vibration frequency to base 2, and in order to bring the upper and lower tones to psychological uniformity, we should take not the direct numbers of vibrations gained by experience, but their logarithms to base 2, i. e. to multiply the usual decimal logarithms taken from the vibration numbers per second obtained by the experiment by the module of the secondary system of logarithms **3.3219** according to the formula: $D=3,3219lgN_0-3,3219lgN_1$, where **D** is the level of half-tone audibility, that is, a European music scale note. **N₀** is a number of a musical

tone double vibrations studied in this respect, and N_1 is the number of the similar vibrations of the tone close to it, which the ear can no longer distinguish. In table 1, we show the logarithmic mantissa of ten semitones of the European musical scale, as ten degrees of audibility of a common European ear of the 20th century, where K is any integer from 5 to 44. The name of the note will be determined by the fractional remainder (mantissa) of the logarithm according to the table below.

Logarithms	The mantissa	The difference
$\lg_2 Do = K,$	044	0,085
$\lg_2 Do\# = \lg_2 Reb = K,$	129	0,085
$\lg_2 Re = K,$	214	0,076
$\lg_2 Re\# = \lg_2 Mib = K,$	290	0,076
$\lg_2 Mi = K,$	366	0,023
$\lg_2 Fa = K,$	459	0,085
$\lg_2 Fa\# = \lg_2 Solb = K,$	544	0,085
$\lg_2 Sol = K,$	629	0,076
$\lg_2 Sol\# = \lg_2 Lab = K,$	705	0,076
$\lg_2 La = K,$	781	0,085
$\lg_2 La\# = \lg_2 Sib = K,$	866	0,085
$\lg_2 Si = K,$	951	0,093
$\lg_2 Do' = K,$	044	

We see that the average intervals between the steps of musical semitones are **0.085**, and therefore any sound that differs from the ones listed in the second column of this table by no more than half the indicated interval (i. e., by no more than **0.042**) is our auditory cochlea relates to the nearest of these numbers, and this makes it possible to easily determine the note of experimental data, without fear of the fact that in high octaves the intervals between the numbers of their vibrations per second are very large. After all, all those with a logarithm difference of less than **0.042** lie within the error range of our voice and hearing organs. That's why it's also necessary to use a notation system when drawing up diagrams, as I adapted it in the following tables: it is exactly the same as the logarithms of the number of

vibrations, although it was developed by composers by intuition in addition to mathematics.

So, this table makes it easy to translate the number of sound vibrations into notes. The mantissa of the logarithms give the name of the note, and their characteristics, where **K** (that is, the whole part of the logarithm), give the octave number by key: **K=5** is contr-octave; **K=6** – large octave; **K=7** – little octave (its end is in the bass key); **K=8** – octave 1 (its end in a treble key); **K=9** – octave 2 (its beginning in the treble key); **K=10** – octave 3; **K=11** – octave 4.

Not all phonetic schools use this octave numbering. So, the French school of phonetics calls the big octave the first, the small one – the second, the first one – the third, etc., and, in addition, all the notes in it are a quarter tone higher, so to get them from the above logarithmic mantissas, you should subtract **0.044**, and for **lg₂Do** it always turns out a zero mantissa (**K.000**), which corresponds to an integer power of two (two full vibrations per second), while on the usual musical scale **2.062** vibrations per second are taken as the starting point. And if a person has become close to these new natural-science ideas about light and sound and does not accept them into his consciousness as some strangers who come for a short while, then he finds in them even more poetry and beauty than in their **ILLUSIONAL MYTHICAL REFLECTIONS**.

* * *

Even, if only during external observation of the Pulsars of the galactic center-forming level, it is necessary to imagine the following: a bright outgoing emission in the opposite directions of the two clearly defined cone-shaped rays – they are the outgoing flows of photons of different design and cosmophysical levels and the corresponding different functional formation; the fixed "sound accompaniment" of the Pulsars' work; they are also photon flows that differ in frequency and, especially, speed characteristics (sounds are the results of the photons outgoing speed characteristics) with corresponding differences in the functional endowment of the galactic, intergalactic collected or other nature.

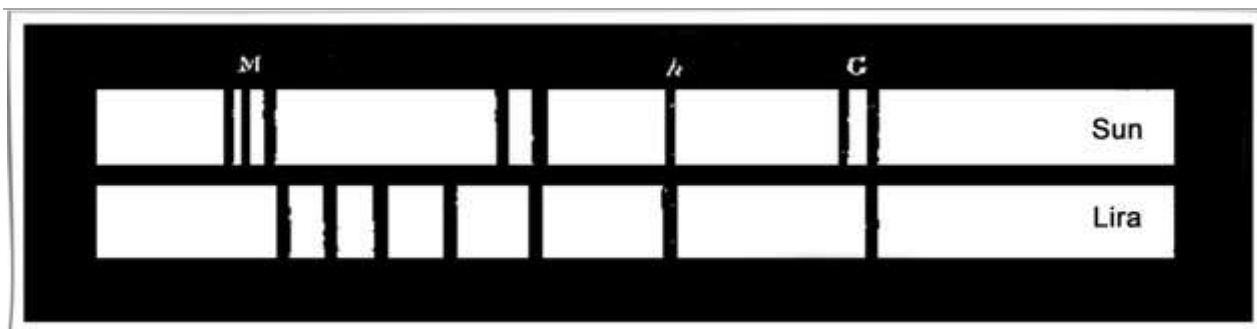

Violet and ultraviolet parts of the continuous spectrum of the Sun and Vega (a-Lyra) with lines of hydrogen (μ) and other gases overlapping them, just as the distinctive metatones of the sounds of human speech overlap continuous noises of the human oral cavity, in which sound waves of various lengths are present (within certain limits).

Each luminous substance, when its rays are decomposed by a prism in a spectroscope, always gives several typical lines lying in perfectly defined places of the rainbow spectral line. By their position and appearance, a chemist immediately recognizes what an unfamiliar mineral consists of, and an astronomer studies the material composition of celestial bodies unattainable to us, determines their age and, comparing them, establishes general laws and successive stages of their evolution. And he sees clearly that the celestial bodies also have their birth, childhood, youth, old age and death, as well as living beings that surround us on the earth's surface. And with previous erroneous ideas, the light rays were deaf and dumb to all the questions raised by man.

Similarly, is *in the field of sounds of human speech*. Each **consonant** sound, represented by a special letter like **b**, **c**, **d** and so on, has its own special phoneme, i. e., a system of typical and unchanging air vibrations in every mouth that reaches our consciousness, the same in the mouth of a man, of a woman, and a child, an old man, while they clearly pronounce the sounds of speech. Only by these phonemes or typical and unchanging metatones accompanying the ordinary sounds of human voices, if they have reached our consciousness, we distinguish between **b**, **v**, **d**, **z** and so on, regardless of whether the person's voice is high or low and its individual features. In music, they are similar to those systems of sound metatones, i. e., accompanying tones, by which we distinguish between long flute tones from the same long violin tones and piano percussion sounds from bell percussion sounds even at the same musical pitch of their main tones, in modulations and combinations of which is the whole harmony of music and speech, regardless of the above systems of extra tones corresponding to phonemes. Say, for example, a long labial sound **va-vi-vo**

or **fa-fi-fo**. Here, in addition to the general hum produced by your mouth, there is also a special series of distinctive metatones for each consonant sound that you have the same with all other people, regardless of their gender and age. Only they alone separate labial **v-v-v** or **f-f-f** sounds from dental **z-z-z** or **s-s-s**, etc. although they are just as long. When these metatones are poorly reproduced by someone, as happens with bad singers, then you stop distinguishing their words from each other. No matter how you analyze the distinctive metatones of the larynx, dental, nasal and other consonants of your voice and the voices of any other people, you will always make sure that all the people whose words you understand have no noticeable difference between them. They remain unchanged when singing, despite raising or lowering in the tones of the glottis, if this singing is clear to you.

At first sight, it will seem somewhat different when you compare not the above consonants, but **the vowels of your speech** with their pronunciation by others, but the same thing comes out, with only one addition. Say, for example, for a long time the syllables **jeee** or **cheee**, **zhaaa** or **chaaa** and compare your vowel pronunciation in these syllables with the pronunciation of others. You will see right now that they are always accompanied (which was not in previous cases with consonants) with a special purely musical sound of your glottis, more high-pitched in women and children than in men and old people, especially if any of the first has a soprano voice, and one of the second speaks bass. You will notice exactly the same with the other vowels of your tongue, that is, with **A, O, E**. Each of them you can sing, raising or lowering the tones of your glottis by means of more or less tension of the **VOCAL CHORDS** in your larynx, but an experimental study with appropriate physical devices will always show you the same thing. With raising or lowering of each of the vowels of human speech, there is one's own unchanging system of the metatones accompanying rumble in the mouth (and not in the glottis!) i. e., a phoneme that does not depend on any arbitrary raising or lowering in your voice when speaking or singing, and, as soon as these metatones disappear, you immediately cease to understand what a vowel sound is: it is immediately turned into a meaningless exclamation for you.

8.4. Logarithms

The science of the sounds of human speech is still young, and its name has not yet been fully defined: some call it phonetics, and others more precisely – **anthropophonics**.

Anthropophonics, deprived of the possibility of its very presentation in the scientific literature through ordinary alphabets, went on its own experimental way. It is difficult to explain the core of this subject without knowing where physiology and physics come into contact with each other. The idea of the English scientist **Willis** about the way people distinguish vowels according to the sounds given by the cavities of the pharynx, mouth, and sometimes nose, and preserving in any voice the same pitch of some of its characteristic tones, remained without consequences for about 34 years – until 1863, when in Germany the famous physicist **Helmholtz** experimentally reproduced, using sound tuning forks, all the typical vowels of the German language and published his ingenious book: ***The Doctrine of Sound Sensations***, which laid the foundation for a new science. Since then, anthropophonics has quickly moved forward. Following Helmholtz's book, Thousing's "***Natural Sound System of Human Speech***" appeared. At the same time, there was an attempt of Dubois-Reymond to create a nationwide alphabet, developed on the scientific basis, which, however, did not bring to any results due to the great inertia of European governments. Our first phonetic laboratories were founded by S. K. Bulich and V. A. Bogoroditsky. What was the core of this new science? It is difficult to explain without touching that area of knowledge where physiology and physics come to contact.

Nikolai A. Morozov so painstakingly and carefully did his research that it is difficult to imagine our knowledge of **anthropophonics** without considering his thoughts of physics and physiology in relation to the structure and activity of our voice organ.

Do we know, or at least sometimes think about it (and most often do not think at all, and not only about it) what exactly in the structure of the vocal organ imparts musicality to our voice; what are the resonators in it; due to which the coloring of our vowels is different; What phonemes do we pay attention to when we want to understand the speaker's emotional state or only to catch the meaning of his speech? There are many questions. It was no coincidence that Alexander M. Khatybov turned his attention to the phonetics, the physiology of sounds, the music of speech in A. Morozov's

works, which inevitably brings us to a deeper understanding of amazing things – how using the sound of a voice organ you can find technologies, which could bring a stone block into resonance and soften it to butter state, for example. Yes, you can "soften" huge stones, transfer multi-ton boulders through the air, and much more, which we, and indeed almost the entire scientific "fraternity", do not even imagine, obscured by their «horse knowledge». But knowing all this, you can understand (if, of course, you need it) the technology of building megalithic structures from huge and carefully fitted stone blocks in Machu Picch, Balbek and Palmyra, which I wrote about in my second book (Ch. 6).

In his writings, Nikolai A. Morozov showed us that knowing the physiology of human speech, by smooth or sharp raising or lowering the tone of the glottis, we can judge about the speaker's mood: they are like the sounds of harmony or the organ, and by themselves do not give any concept about such components of human speech as **A, O, Y**, etc. We have the idea of **VOWEL SOUNDS OF SPEECH** exclusively from our arbitrary bringing of special, extraneous metatones that we mix in the musical tones of the glottis by imparting our mouth and lips certain forms and the formation in the mouth of a noisy constriction between both lips or between the tongue and the palate. Only on these phonemes (as they are called), and not on the vocal cords main tone do we pay attention when we want to perceive not the inner mood of the speaker, but only the meaning of his speech. Here there is also a reason why gramophones can also speak human voice. Look at the bends of the circumferential lines on their plates, along which the needle goes, making vibrate the sounding membrane, and you will see on them under the microscope main tone vibrations that add melodiousness and impressiveness to the voice, and these metatone vibrations that only give a certain meaning to the singing waves.

In **1877**, Thomas Edison tested the first device capable of reproducing sound – the phonograph. He was inspired to create such a device by a small incident that happened to him while working on the telephone device. The scientist sorted the phone in order to improve it and at work began to quietly hum. He was holding a membrane with a needle in his hand. The metal plate responded to the voice, and the needle pricked the finger of the inventor. This gave him the idea that you can record the vibrations of the needle and then let it go along this path.

And now let us examine the structure and activity of our vocal organ.

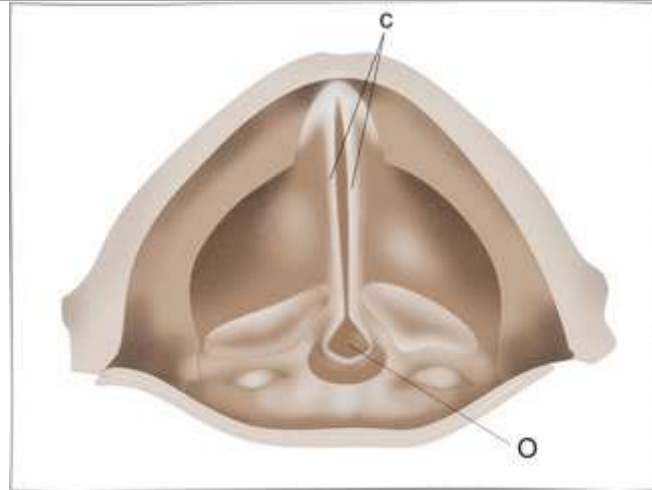

Cross section of the human respiratory organ

O – cartilaginous fissure, when passing through which air makes noise; the part of its metatones, reinforced by the resonators of the oral and nasal cavities, gives a distinctive coloring to our vowel sounds. **c** – "blades" of the glottis, the vibrations of which impart musicality to our voice and serve to express feelings, especially when singing.



Human throat longitudinal section

We see that our larynx, beginning immediately behind the pharynx, consists of several cartilages connected by ligaments to the hyoid bone, and also to one another, and is covered with muscles. The mucous membrane lining the laryngeal cavity forms two paired folds, going from front to back, between which remains, as continuation of each other, vocal and

cartilaginous fissure. Passing through the first part of the common glottis, the air shakes its stretched edges and this causes a musical sound as in any wind instrument, and the tone of this sound rises with greater tension of the edges and lowers when relaxing according to the general physical laws of stretched sounding strings. In the Russian expressive language, these rising and lowering reach an octave, and in Italian speech they are even higher. In singing, good artists rise to two octaves on this fissure. Passing through **the second cartilaginous** part of the same fissure, the air produces common noise, and this noise differs from the musical sound by mixing with all kinds of tones. This is like a continuous spectrum of sunlight, in which there are light waves of various vibration frequencies, while in the above described the glottis musical tone with each specific tension is similar to the light of gasses in which only a few perfectly defined vibration frequencies are detected, overlapping the continuous spectrum, like the Fraunhofer lines on the general solar spectrum.

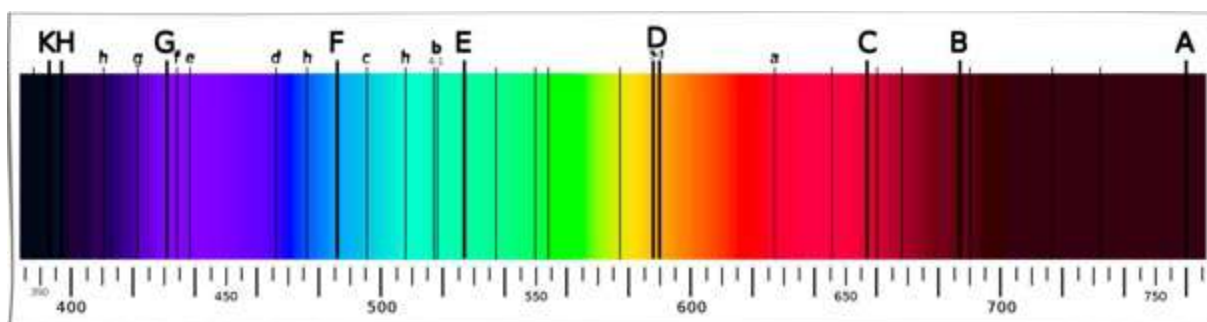

The Fraunhofer lines are the absorption lines visible against a continuous spectrum of stars. They were discovered in 1802 by the English physicist and chemist **William Wollaston** and examined and described in detail by the German physicist **Joseph Fraunhofer** in 1814 while doing spectroscopic observations of the Sun.

Why am I describing everything in such detail and taking information from N. Morozov and A. Khatybov, without forgetting about N. Levashov? Well, just because I want to show you the relationship of this information as a certain element of **the "SvetL" Programs and the Generator's work**, in which all this is taken into account and controlled both "mentally" and with voice, bearing in mind the above.

However, the harmonic vibrations of the glottis edges, and the noise produced by its cartilaginous part for the vowels, and the noise produced in the fissure of the lips for the labial consonants or in various more internal fissures between the tongue and the palate, would be too weak if it had not been added to them the resonance of the mouth, nose or glottis, and even large bronchi. **THE RESONATORS ARE LIKE SWING**: as the latter can

be swung by weak but timely pushes, so in the resonators only those vocal vibrations are amplified that are characteristic of the resonators themselves, i.e. those that push them like a swing, and therefore, against the continuous background of sound spectra they are very much distinguished, along with the melodious tones of the vocal cords, emanating from the oral or nasal cavity and taking new timbre with each new formation of these extension tubes, an analog of a trumpet gramophone.

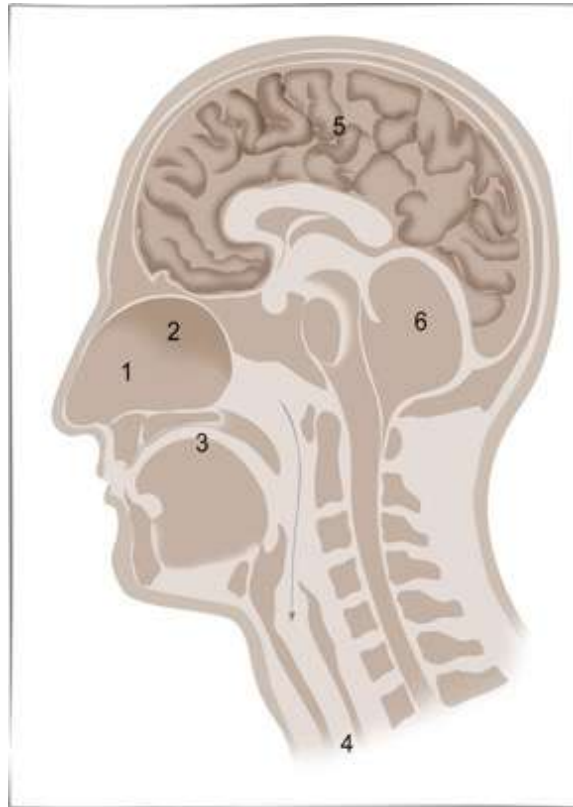

Human Head Section

(1 and 2 – a nasal cavity resonator that raises the desired nasal metatones. The oral cavity and pharynx resonator (3) is above the glottis (4). At the top is a large (5) brain and cerebellum (6) as regulatory organs).

Only those brain impulses we take for separate **SYLLABLES OF OUR SPEECH**, which we send to the glottis to stop or change the tone of its musical sounds, but not those impulses that are simultaneously sent by us to the oral or nasal cavity to trigger off some distinctive overtones of each new sound of speech; we do not pay any attention to its musicality and rhythm, although it is their changes that impart meaning to the simple music of our glottis. Without them, as I have already mentioned, this music would have been like a trumpet sound, in which neither **a**, nor **o**, nor **y** could be heard, not to mention some consonant sounds. All that could have been heard in it is interrogative, exclamatory, affirmative, approving, reproof, surprising intonation, as shown in the figures below.



Rising and lowering melodic tones of the glottis with different nuances of the same phrase (pay attention to the underlined words)

Using the structure and activity of the vocal organ as an example, N. Morozov analyzed the distinctive metatones of the guttural, dental, nasal, and other **consonants of OUR (RUSSIAN) SPEECH** and made sure that all the consonants pronounced by different people, in the words we understand, have no noticeable difference between them. They remain unchanged when singing, too, despite rising and lowering of the tones in the glottis. Somewhat different is with **the vowels** of our speech, the way they are pronounced by others, but the same thing comes out here, with only one addition, as described above.

In the languages of the Mediterranean ethnic group, purely nasal vowels are not found, and there are only five main pairs of vowels pronounced with a necessarily open mouth, and each pair consists of **LOW-TONE AND HIGH-TONE VARIATIONS**, as shown in the diagram.

Hard (Low-tone)	Soft (High-tone)
Дух... У	Û... Нюня
Сон... О	Ö... Лёля
Даль... А	Ä... Дядя
Шест... Ё	Ë... Дело
Бык... Ы	İ... Кій

However, this binding pairing of all five main vowels is poorly realized even by average educated people due to the fact that **no European language has a complete set of these five pairs**, and even we, Russians, especially rich in speech sounds, have only one pair in our language: **Ы** and **İ**; and the other four vowels have no pairs. The Germans and French have only **О** and **Ö** and **У** – **Û** pairs, and only hints at **А**, and the English pronounce well only pairs of **А** and **Ä**, **О** and **Ö**, and none of the European peoples use the hard oriental **Ё**, which we clearly hear in the dialect of oriental peoples, for example, Caucasians, when they say "r€ka T€rek",

and which I arbitrarily showed in the table, turning the letter **Ә** in the form of **Є**.

Diagram of the main vowels of the Mediterranean ethnic group

Hard (Low-tone)	Soft (High-tone)
Russian Ъ	İ – Eest-Europe
Russian. А	Ä – English
Russian. Ы	Ö – German
Low-tone Ә = Є	Е – Europe
German U	Ü – German

Here **А** correlates with **Ä** as **О** with **Ö**, **Є** with **Ә**, **U** with **Ü**, **Ъ** with **İ**. For **U** Latin transcription is taken, since Russian **U** is similar to Western European **Y**. Only for us, Russians, it is easy to pronounce all these five variations, since we have a pretty good nuances of them: for **A** in the word nanny, for **Ö** in the word Lyolia and for **Ü**, in the word nu:nia. And for an accurate melodious pronunciation, they should be heard more than once by both the British and the Germans, since our vowels **Я** and **Ю** are pronounced like syllables **ya** and **yu**. The exact definition of their typical unchangeable metatones, unfortunately, is much complicated by the admixture of many different extraneous individual and local tones, to which we do not attach meaningful value, but thanks to which we recognize immediately by the voice, even in the dark, every person familiar to us, if he only answers the question: "who is there? " It is me (YA). The mere fact of having from each hard vowel a correlating soft one shows that there is a certain relationship between the characteristic metatones of both. N. Morozov found these dependencies, taking data from the experiments of scientists Helmholtz, Donders and Shcherba⁹⁷ and supplementing them with some Poirot metatones, translated into notes those of them, which gave him a sound suitable for the given vowel by the piano. The results can be seen in this figure by N. Morozov.

⁹⁷ L.V. Shcherba. Russian vowels in qualitative and quantitative terms. 1921

		According to German notes. Number of vibrations per second:			
5th oktave					
	4224	4752	c ^v (do)	d ^v (re)	
4th oktave	3520	3960	a ^v (la)	h ^v (si ^b)	
	2816	3168	f ^v (fa)	g ^v (sol)	
3rd oktave	2376	2640	d ^{iv} (re)	e ^{iv} (mi)	
	1980	2112	h ⁱⁱⁱ (si ^b)	c ^{iv} (do)	
2nd oktave	1584	1760	g ⁱⁱⁱ (sol)	a ⁱⁱⁱ (la)	
	1320	1408	f ⁱⁱⁱ (fa)	f ⁱⁱⁱ (fa)	
1st oktave	1056	1188	e ⁱⁱⁱ (mi)	d ⁱⁱⁱ (re)	
	880	990	c ⁱⁱⁱ (do)	h ⁱⁱ (si ^b)	
Small oktave	704	792	a ⁱⁱ (la)	g ⁱⁱ (sol)	
	594	660	f ⁱⁱ (fa)	e ⁱⁱ (mi)	
Big oktave	495	528	d ⁱⁱ (re)	c ⁱⁱ (do)	
	396	440	h ⁱ (si ^b)	a ⁱ (la)	
Counter-oktave	330	352	g ⁱ (sol)	f ⁱ (fa)	
	264	297	e ⁱ (mi)	d ⁱ (re)	
Ultra-oktave	220	247 1/2	c ⁱ (do)	h ⁱ (si ^b)	
	176	198	a ⁱ (la)	g ⁱ (sol)	
	148 1/2	165	f ⁱ (fa)	e ⁱ (mi)	
	123 3/4	132	d ⁱ (re)	c ⁱ (do)	
	99	110	H ⁱ (si ^b)	A ⁱ (la)	
	82 1/2	88	G ⁱ (sol)	F ⁱ (fa)	
	66	74 1/4	E ⁱ (mi)	D ⁱ (re)	
	55	61 7/8	C ⁱ (do)	H ⁱ (si ^b)	
	44	49,5	A ⁱ (la)	G ⁱ (sol)	
	37 7/8	41 1/4	F ⁱ (fa)	E ⁱ (mi)	
	30 9/16	33	D ⁱ (re)	G ⁱ (do)	
	24 3/4	27 1/2	H ⁱⁱ (si ^b)	G ⁱⁱ (la)	
	20 3/4	22	H ⁱⁱ (sol)	F ⁱⁱ (fa)	
	16 1/2	18 1/2	E ⁱⁱ (mi)	D ⁱⁱ (re)	
		C ⁱⁱ (do)		Ü Ö Ä Ë Ī U O A € Ъ Whispering voice Front (soft) akusmas West-Europe dialects Back (hard) akusmas East-Europe dialects Upper limit of tone perception of modern Europeans.	

Some of the distinctive metatones that necessarily link up when pronouncing the indicated vowels. Compiled by the author according to **Helmholtz, Donders, Shcherba** and **Poirot** with their auditory tests. Black notes – according to Helmholtz, shaded – according to Donders, contour – according to Shcherba, with a double rim – according to Poirot. Those notes in which the attributes of the system are not found (yet) may belong to local or individual vocal coloraturas of these researchers or their objects.

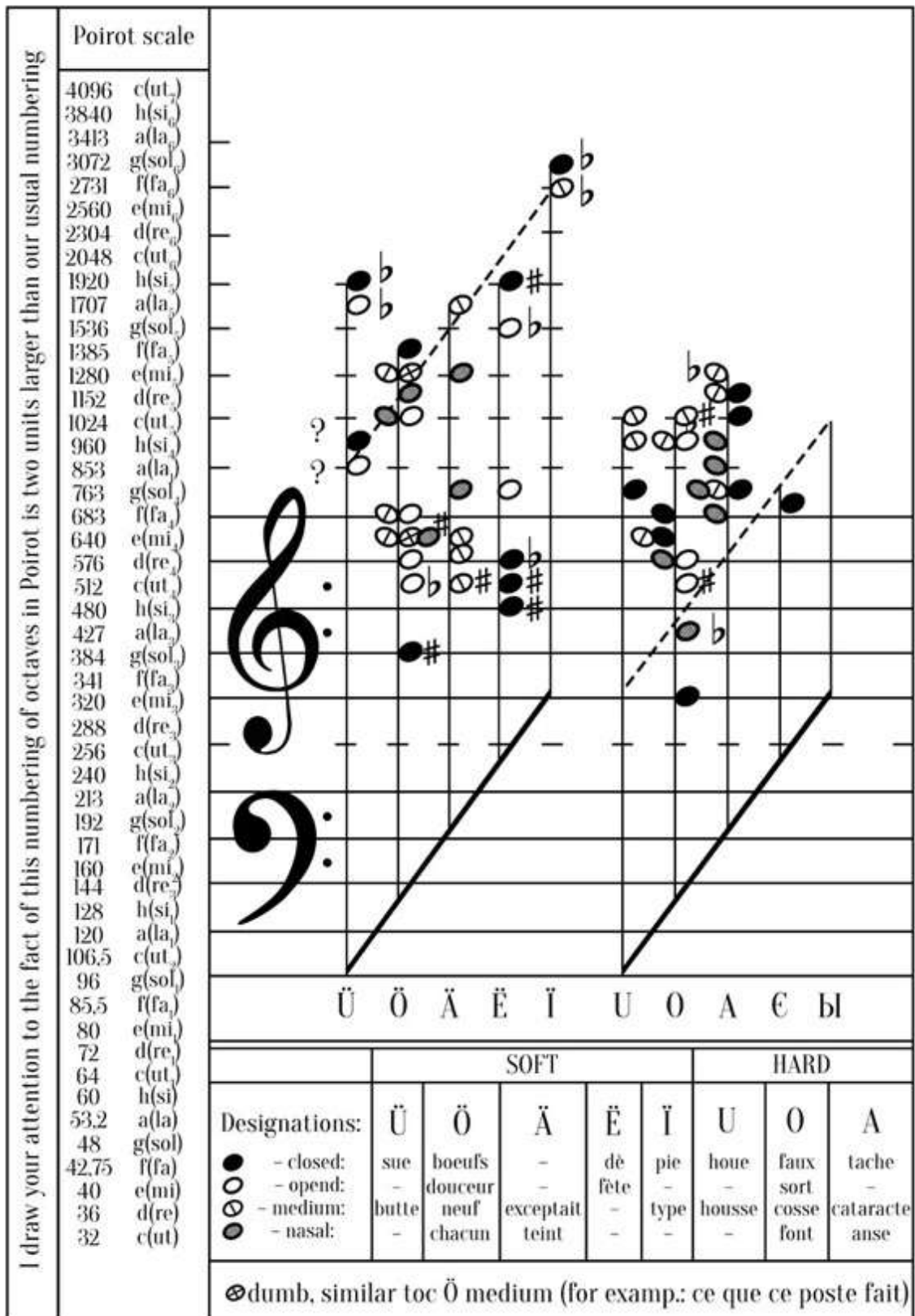

French vowels by J. Poirot. (Arrangement according to the schedule of experimental results of the book: Jean Poirot. Recherches experimentales sur le timbre des voyelles transcrites. Paris. 1912..)

This is a clear characteristic of the local French dialect, by which we would distinguish between Poirot's speech in Russian in the next room and the speech of his interlocutor.

From this comparison it is clear that only those located in the upper section of the first (soft) group near the dotted line can be distinguishing metatones. Those that lie between the five lines of the treble clef and which Poirot calls the resonance of the back of the oral cavity are only coloraturas of his dialect, since they are too close to each other to be phoneme differences. The same can be said about all notes of the second group.

Take my word for it, but there is still a lot of work to be done here in order to find the **EXISTING REGULARITY** in the transition from the typical distinctive metatones of soft vowels to the corresponding hard ones: you can clearly hear it with your ear. This is important, and especially in our present time, when all the information "is suddenly coming in Russian".

The "Morozov Square" – this is what Khatybov calls the system compiled by N. Morozov himself, which enabled him to independently learn the pronunciation of several consonants that did not exist in languages he knew before. Morozov called this system a "**method of sound squares**". On its basis, he compiled an international alphabet. I suppose that A. M. Khatybov's conclusion that man consists of atomic reactors, and similar vocal cords of people of different races «pronounce» sounds in different ways, was influenced by Morozov's works.

8.5. The Morozov Square

The first time I heard about the Morozov Square from N. Levashov when he told me about the concealed meaning of many words that we just do not pay attention to. Take, for example, "Doctor of Science", a familiar and respected name, emphasizing man's "knowledge" and his status in modern scientific society.

The word "**doctor**" consists of two words – "**Doc(a)**", one of the meanings and the most objective – "**interpreter**" and the word **Tor(ah)**. The Torah – (Greek) – πεντάτευχος) or **the Book of Moses**, both the text itself and the printed or handwritten copies (scrolls). However, Torah is somewhat different – it is a plan to



achieve the set certain goals in the development of the Brain genotypes, if we summarize everything that this «document» includes. And now, combining all this, we get – **Doctor of Sciences** is the **TORAH INTERPRETER**.

What is the point of the Morozov square? Morozov notes **POWERLESSNESS** of our **USUAL ALPHABETS** in the natural classification of speech sounds and the need for a systematic alphabet. In his studies, he clearly shows that the "magic" signs of the Jewish alphabet, from which, seemingly, Greek, and then Latin, Coptic and Slavic ones originated, **were not invented by anyone in the finished form and were not given by any god to the legendary Abraham**. They developed from primitive drawings of objects, through improvement, and, moreover, going from complex to simple, until the whole alphabet came to phonetics. While studying the alphabet, Morozov asks the question whether the current state of the alphabet is the end of its development. Of course not! And then he shows that our modern alphabets are still far from the last stage of their development, that they will have further evolution in the future. And he shows the most probable way and the limit of the ultimate perfection, in which all alphabets will have to come to the simplest and most rational way, and what great results such a language will lead to and how easy it will be to study all sciences in that language.

If in ancient languages, **not excluding the pseudo-divine Chaldean-Hebrew, invented according to the biblical legend by the first man "Adam"**, there was no conformity between the letter composition of names and the elementary composition of the denoted objects due to the randomness of primitive names, then is it possible that in the future such an international language will be developed in which only its alphabetic composition could give us the opportunity to describe in nearly all detail the **OBJECT NEVER SEEN BY US** only the name that we hear for the first time? We can answer only affirmatively. Such an international language is not only possible, but it inevitably is to be developed (or rather, we are to return to it), because without it, human intellect will not be able to rise to the new, higher stage of its development. After gaining this stage man without spending decades for his studying and training, will be able to cover almost the entire range of modern scientific knowledge since childhood. The direct inevitability of this follows from the rapid evolution of all our sciences today. With this goal in mind, Morozov suggests his own example of an international alphabet of just 5 **vowels** and 9 **consonants** instead of 80 vowels and more than 200 consonants. For this he proposes his own system of sound squares. Some can agree with this today, others can disagree, but it

is absolutely necessary to understand it in order to gain new knowledge. And this, in my opinion, is the most important.

Individual or even local features, by which we distinguish the dialect of different areas of the same language, do not matter for phonemics. Only those which impart a new meaning to the word and can be pronounced after some learning are important here. Therefore, ***in the science of human speech sounds***, it is necessary to strictly separate distinctive metatones from purely coloratura ones that are part of the same phoneme, i.e., the same complex sound of speech that vibrates one or another group of fibers of our ear snail. But, unfortunately, this separation is very difficult to make, and it accounts for a certain difference in the number of the same phoneme in different linguistic fields and different researchers. To make it clear, Morozov investigated the metatones of the above five pairs of vowels of European dialects, that is, the metatones of vowel phonemes:

9. **Low-tone phoneme Ъ (Y)** – is almost completely missing in Western European languages, but very common in Slavic languages. The lowest of its distinctive metatones in Russian, Polish, Ludice and Romanian dialects (according to Shcherba) is close to 996 vibrations per second, and in Romanian it is close to 1156 vibrations. The corresponding high-tone phoneme **Й** (i. e., soft **Ъ** (y)) is characterized by the fact that the lowest of its distinctive tones is three times higher than just indicated. In the Russian and other Slavic languages, in isolated **И** (I), – about 3044 vibrations per second. In the Russian language the letter **Ъ** (Y) is often pronounced as **И** (I).

10. **Low-tone vowel phoneme А** in its distinctive overtones is lower than the previous one. Among other Slavic languages, phoneme **А** is about the same in its coloratura (according to Shcherba) in Polish, Czech, Slovin, Ludice and Ganak dialects and is somewhat different from Little Russian and Serbian. The corresponding high-tone (soft) phoneme **А** is very common only in the English dialect. If this comparison is true, that the distinctive overtones of soft vowel variations are characterized by a three times higher vibration frequency, then we find here an echo of about 2600 vibrations per second.

11. **Low-tone phoneme О**. Sound **О** is heard in our speech approximately three times less than this letter is written. When isolated or with a clear pronunciation under stress, low-tone Phoneme **О** has a rather low metatone in its distinctive series. For the Russian language, this is about 756 vibrations per second. The high-tone (soft) variation of **О** corresponding to this Phoneme is very common in German, English, and French, but is missing in Slavic and Italian.

12. **Low-tone phoneme Ё**, (which is denoted as inverted **Э**) is very common in Oriental languages and among them – in Caucasian. There is a high-tone (soft) variation corresponding to this Phoneme in the Russian language both in letter **Э** (это) and in the syllabic **Е** (непрв, etc.). It is identical

with the French closed *ë* (*chanter*, etc.), it is close to German, English, Polish, Serbian, Slovenian and Ludice *O*, especially after soft consonants. The high-tone variation is characterized by a three-fold higher vibration frequency of characteristic metatones; we see that for low-tone Oriental *Є* there must be metatones of about 600-650 vibrations.

13. **Low-tone phoneme U** in Russian is similar to the rest Slavic languages and is close to the Western European languages. The lowest of its characteristic metatones is indicated by a tuning fork at about 432 vibrations per second. Here we find by the previous one that for its high-tone variation there must be overtones of about 1400 full vibrations per second.

These are five main pairs of vowels of speech pronounced exclusively by the oral cavity. We can pronounce each of them in a whisper, that is, without the vocal cords vibration, and this sufficiently shows how insignificant such vibrations are for the distinctive coloratura of our vowels. Only some kind of noise is needed in the cartilaginous part of the glottis, so that the resonance of the correspondingly located our mouth cavity amplifies one or another of the huge number of tones that exist in each noise, and, thus, would impart proper coloratura to the pronounced vowel. And the fact that these noises are produced by our breathing is clear from the fact that, when interrupting breathing, we do not utter a word. Most European nations have **ONLY** the **ABOVE FIVE PAIRS** of vowels, and not in the complete series. Secondary phonemic variations of them are, in addition to the stressed and unstressed position, their deep and superficial pronunciation. Thus, for each of the five main vowels, a sound square comes out in which one side is *thoracic* and the other *pharyngeal*, one – *low-tone*, and the other – *high-tone*.

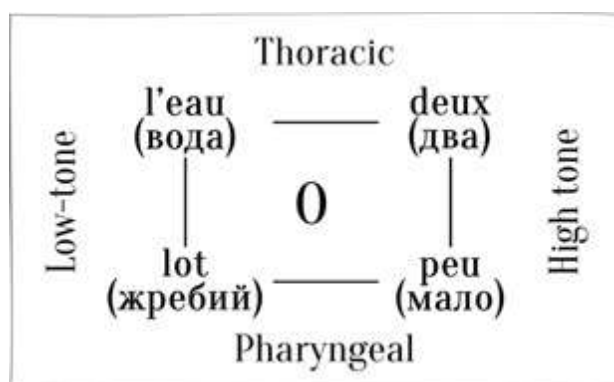

Four phoneme variations of vowel O

Similar squares for **A**, **E**, **U** and **И**. Altogether we have 20 **Phoneme vowels**, which, in comparative linguistics, must be pronounced and transcribed separately in writing. In addition, each of these phonemes may

also have nasal and phonemic pronunciation. ***It does not exist in the Russian language.*** This phoneme is present, in addition to French and Portuguese, in the Polish dialect and in some others. And from the previous 20 vowels of the Phonemes, we have already had 40. But this is not enough. In English, some of the same basic vowel sounds of speech can get a ***pharyngeal*** overtone, similar to mispronouncing R. It is defined in the transcription by the prefix to this vowel of R, for example, in: ***you are, or: you were*** or: ***yearbook***, but when you listen attentively to (especially when singing) a good pronunciation, you hear that there is no R, and the whole vowel from beginning to end is mispronounced, that is, with pharyngeal overtones. This allows doubling of all 20 simple vowels, and then together with the nasal they make up 80 generic phonemic vowel variations. And the Chinese have a ***shrill*** pharyngeal pronunciation for all 20 primary vowels, and this adds 40 more characters, and the ***hoarse*** guttural pronunciation of some peoples can give the same amount. It is clear that to compile 160 separate symbols for them necessary for scientific phonemics or even for the correct transcription in one's own language of foreign surnames and names, of cities and towns, is completely impossible if we do this by simple addition to the historically developed alphabets. But it's quite different if we come up with a systematic alphabet.

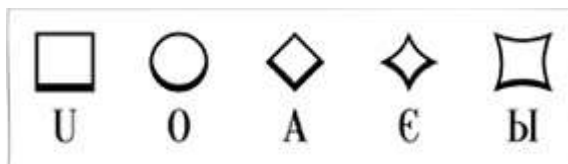

When Morozov was still in the Shlisselburg fortress and did not know anything about anthropophones, or about ***Du Bois-Reimont's*** attempt to make up a scientific alphabet, the same idea came up to him, and he came to the conclusion that all this can be easily done in print. We need to take only five figures in the first line, which are good for clear distinguishing from one another and for making regular variations out of them in gender

This is a low-tone (hard) European series. Turning these signs upside down (line two), we get a high-tone series, where *the thickening* shows rising in typical overtones. Turning their thickening to the left (line three), we have for each of them a low-tone deep (broad) pronunciation. Turning the thickening to the right (line four), we get a deep (broad) pronunciation of the soft ones. Putting the ***nasal sign inside*** each of the 20 previous ones, we get their nasal pronunciation as in the French words: ***bon, an, un***, etc. (line five). Adding ***a horizontal hyphen*** (line six), we get an English mispronounced pronunciation. Putting the same ***hyphen in the direction***

from top to bottom we get a shrill Chinese, putting the same hyphen sideways from left to right, we have the opportunity to get the guttural pronunciation. Having done the same, and then, if necessary, turning the *hyphens into crosses*, or making them **serpentine** instead of direct, you can get material for any number of variations.

In my opinion, N. Morozov deliberately chose these regular figures from one of those samples, which he developed during his first years of imprisonment in Peter and Paul's fortress drawing them on the walls of his cell (for the lack of paper), for which he was rudely reprimanded by the head of this institution who ordered it to be washed away. Those figures, as he wrote, helped him a lot in sorting out this poorly developed field of knowledge at the time when anthropophonics did not exist. Until his last days, he believed that we, the Russians, should be the first to start compiling such a rational alphabet, since the rest of the cultural peoples cannot pronounce foreign sounds.

In the hand-written letters, which is mainly reduced to cursive writing, and where, because of this, even modern letters have become unlike the printed ones, we will have to go in a special evolutionary way, leaving all the letters as they were, and only giving new transcriptions to the missing vowels like low-tone **Є**, or high-tone **А**, **О**, and **У** missing in the Russian alphabet, so that foreign names could be spelled correctly. It will be very easy to get used to reading print with these few replacements and having all consonants temporarily unchanged.

According to the system just given, the most frequent letter **О** remains unchanged, and some of the others are rather close to Russian. It is necessary to develop something very new so that the science of human languages would not forever remain a withering away tree that grows not in the earth, but in a cramped pot that does not allow its roots to spread freely.

Everything that is said about the phonemic, local and individual coloratura of the **HUMAN PRONUNCIATION OF VOWEL SOUNDS**

Short	"hard"	□	○	◇	◊	◻	U	O	A	Є	Ы
	"soft"	◻	◊	◊	◊	◻	Ü	Ö	Ä	ÿ	İ
Long	"hard"	□	○	◇	◊	◻	Ū	Ō	Ā	Ė	Ы̄
	"soft"	◻	◊	◊	◊	◻	Ū̄	Ō̄	Ā̄	Ė̄	Ы̄̄
II											
Short	nasal	◻	○	◇	◊	◻	Ū̃	Ō̃	Ā̃	Ė̃	Ы̃
Short	mispronounced	□	○	◇	◊	◻	Ū̄̄	Ō̄̄	Ā̄̄	Ė̄̄	Ы̄̄̄
etc.											

produced by the glottis also applies to consonants produced by the noises arising from the friction of air flows in the fissures of the oral cavity, pharynx and nose, while voice strings are always inactive. Because of this, we don't get a syllable from some consonants, and they are as something outside the rhythms of poems or singing, created by the correct alternation of only stressed-long vowels with unstressed-short vowels produced by the glottis. A Russian child inherits the ability to pronounce only the sound A, which is heard in his first cry when he is born, then he begins to imitate the sounds I and U pronounced by adults, assimilates hard A and O and soft E, and only then, much later, begins, where necessary, to replace I with BI (Y). The first of his consonants are labial explosives: P, B, M (hard and soft) then soft T, D, H and Ы (IY); then K and long B, C, and after them soft L and P, and at first they are identified with I, and only with BI the child begins to pronounce hard L and R.

Depending on where a noisy fissure is created in the oral cavity, typical oral consonants are divided, as is known from textbooks, into labial, lingual-dental, lingual-gingival, lingual-palatine, lingual-pharyngeal and guttural. Various scholars give different names, but all classifications that still exist **CANNOT BE CALLED SCIENTIFIC**, because none of them makes it possible to predict the existence of **consonants** that are not included in our native language, but that are possible in other languages unknown to us, and cannot show us how to pronounce them correctly.

I give you here the Morozov system, which enabled him in the first years of solitary confinement and without teachers to learn the pronunciation of several consonants that did not exist in the languages he knew before so well that when he later spoke to the people who knew them, they did not have to make almost any corrections in his pronunciation. This **method he called then the method of sound squares**.

This is how he himself shows the meaning of his method in the labial square, since in most European languages there are all four of its representatives.

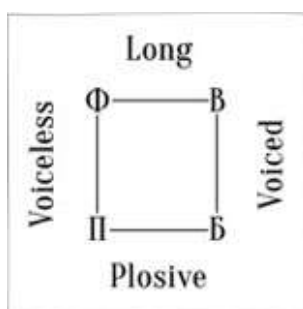

Labial phonemic square

Morozov writes: what do we see in it? After all, this is the same labial noise **FFF**, pronounced in four different tones! The first pronunciation of **F** of this labial sound is voiceless, because it does not change in whispering. It is **long pronunciation**, because you can make it as long as you like. The second pronunciation of **V** is also long, but it is already voiced, because here there are vibrations in the throat, as you can easily feel with your finger on it: when pronouncing **fff**, there are no vibrations in the throat, and when – **vvv**, it vibrates clearly. And as soon as you start pronouncing **VVV** in a whisper, it turns into **fff**. These are the properties of the upper long side of the labial square, and in the lower side you see their plosive analogues: **P** is plosive of **F**, and **B** is plosive of **V**, because they differ from the first ones only in that the sound **P** and **B** break closed lips, and with **F** and **V**, lips slightly open at first. Hence, **P** is a voiceless plosive of **F**, and **B** is a voiced plosive of **V**; the sound of the first, long-lasting variations is similar to the sound of a violin string when the bow goes along it, and the sound of the second one is similar to the sound of the same string, if you pinch it. In Russian, the entire square has a soft (palatal) variation.

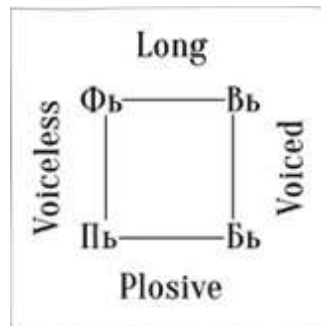





The long (upper) side of the labial sound square can be pronounced intensely long, which is transcribed with the double letter (for example: affect, Avvakum), and the lower plosive side, accordingly, – as if with a stutter (appetite, abbot). If we take an alike transcription for all variations of the labial sound, for example, in the form of **Z** with a stroke, then, varying the transcription and position of this stroke, we would systematically present (in print) all these modifications, for example, as in the **figure below** (left). Having attached small flags to the ends of the strokes, we would indicate their soft pronunciation (on the right). Making the strokes blacker, we would show their intensely long pronunciation, and making the end look like a question mark, we would indicate blowing, etc., etc.

It is clear that if we take common transcription for all these back palatal sounds, for example, in the form of **C** with an attached stroke, we will get their systematic presentation (in print), similar to a labial square (figure above, on the left). And through the flags (figure above, on the right), thickenings and curvatures of the attached stroke, as in the previous ones, we show their soft, intensely long, blown and all other possible transcriptions.

Similarly to the previous squares, we have in the spoken Russian complete **back-gingival**, **front-gingival**, or dental phonemic squares, as well as hard and soft **front-gingival** squares, a **middle-lingual front-palatal phonemic square** both soft and hard. At the same time, Morozov pays attention to all available languages. He uses not only Russian spelling, but also German, French, Italian, English, and many others. He also considers alphabets of the Italian, Latin, Greek, and all known to him languages; but also sounds in Polish, Belarusian, Latvian, Ukrainian, Mongolian, Transcaucasian dialects and others. Through the theory of sound squares, he shows not only the **SHORTCOMINGS IN THE RUSSIAN ALPHABET**, but also which phonemic squares are not quite stable among different people and nations.

Imparting to all variations of each sound a common transcription in the form of, for example, a quadrangle with an attached stroke, it is possible to present all these details in a very simply way by the previous method. Having taken the necessary description – a stroke, a figure, or a removed flag, or add to it a common symbol of all consonants – a stroke, and then there come out corresponding variations for the pronunciation of certain consonants of our languages or other European languages. It is possible that in a certain square the sounds of some peoples will differ from the pronunciations of the European square, then it will be necessary to give systematic figure -variations of one main figure, which were given here for all previous sound squares. After all, it is quite clear that each sound of our mouth can have a long and plosive, voiced or voiceless variation, or, as it is usually called, but less characteristic – a voiceless variation without a guttural tone. No less painstakingly Morozov investigates groups of **consonant phonemes** with complex resonances, as well as trembling and rumbling sounds. And if there are no words in the European languages which meaning would vary depending on one or another way of their pronunciation, among many non-European dialects, there are undoubtedly those where these variations give the words a new meaning, and therefore they should be introduced into the scientific rational alphabet, and even into

our ordinary one, at least to denote the existing various nasal signs of attention. In all cases, Morozov clearly demonstrated the possibility and even the necessity of the four variations existence: **voiced and voiceless, long and plosive, and this makes up 36 elementary sounds**. And with their soft (palatal) pronunciation, common for the Slavic languages, doubles them to 72. The possibilities to give each of them **blow-like pronunciation** brings their number to 144. The possibility of **long-tensed and short-weakened pronunciation** makes up 288 transcriptions. But that is not the end. In addition to all this, you can impart to some consonants a trembling and rumbling character, which, for example, is in the labial sound that we use to stop horses, which is conditionally spelled as "TPRUO!", although **T** is absent in pronunciation, and **R** is different than in ordinary speech. Such sounds can be transcribed by our systematic alphabet by adding wavy flags to the corresponding consonants, as shown in the figure below.

Rumbling consonants	
 Simple "hard" Ъ (Mispronounced)	 Rumbling "hard" Ъ (-R) (Mispronounced)
 Simple "soft" Ъ (-Й) (Mispronounced and childish Ююик)	 Rumbling "soft" Ъ (-РЬ) (Common russian Рюрик)

Rumbling phoneme Ъ

What do we see in the above? A very important thing. In order to have transcription for each of the main **consonants** of human speech, now heard in Europe and adjacent parts of Asia and Africa, we need to have about 80 **vowel transcriptions**, and more than one and a half hundred **consonant transcriptions** must be added to them, and this makes up more than 200 necessary for the scientific alphabet. And in the systematic transcription for the sample proposed here, it comes down to *five vowels* and *nine consonants*. Everything else is achieved by several of their systematic variations, which are as easy to get used to because of their uniformity, as it is easy to learn that the consonant before Ъ in the Russian writing gets soft.



The entire international alphabet in systematic transcription

Therefore, the question was reduced even then to: whether the systematic figures invented by N. Morozov in the Shlisselburg fortress are good enough or something better can be invented.

8.6. Image and Language

Let us consider our understanding of not only the alphabet and azbuka, but also azbuka of the mental language: *thoughts, images, letters, syllables, words in the light of etymology and imageology*. This will allow us to correctly comprehend the *Morozov Square* and continue our reflections in this direction.

In the Slavic-Aryan Vedas we read: "***Do not mix up your native speech with the words and dialects of the foreign language, only native words live in the hearts, and foreign words are dead for the Soul***".

The words: alphabet and azbuka most people take for the same word. Although this is not nearly so. ***Azbuka is a Slavic word, alphabet is Greek***. The word "azbuka" consists of the names of its first two letters – ***Az*** and ***Buki***. The alphabet is from the first two Greek letters: ***alpha and beta***. It would seem no difference. Nevertheless, there is a fundamental difference: ***in the azbuka we have letters-images, in the alphabet – just phonemes***⁹⁸. The alphabet is a regulated set of letters, and the azbuka is

⁹⁸ **Phonema** (dr. Greek. Φώνημα – "sound") is the minimum unit of the sound structure of a language. The phoneme does not have an independent lexical or grammatical meaning, but serves to distinguish and identify the significant units of the language (morphemes and words): when replacing one phoneme with another, we get another word (<d> om – <t> ohm);

the ABC book – school primer. Alphabet (Greek) Alpha + Vita – Greek alphabet book consisting of letters-phonemes.

Azbuka (Slav.) AZЪ + buki – Slavic primer, consisting of the alphabet of initial letters-images, abbreviations. The azbuka consists of letters (letters), which have their own figurative name and meaning (**A – Az, B(B) – Booki, B(V) – Vedi** and so on). Studying the Old Slavonic azbuka, an outstanding Russian scientist, Platon Lukashevich showed that in fact the **"Azbuka" is a cryptography that has a deep philosophical meaning**. And this is a very accurate definition, the comprehension of which is manifested today among many people. Each letter of the **AZBUKA** has a deep meaning and image that defines its meaning. Deep reading is the knowledge of the **AZBUKA TRUTHS**. Sergey Danilov told people in detail and much about this and often referred to Platon Lukashevich, emphasizing his deep knowledge of all the secrets of the ancient language, which gave a clue to the mysteries and the information that is laid in it. **Read the works of Platon Lukashevich and get to know what is encoded in the name of Alexander Sergeevich Pushkin**. At the same time, you will learn a lot about your name, if you wish. Alphabetical truths (truism) help to understand the original, true meaning of a word, that is, the **IMAGE WHICH IS HIDDEN** in the letters-mages. If we add the letters-images – AZЪ + Buki + Vedi into one phrase, we get: "I know the letters and understand their Images", or "I know the letters and understand their meaning; or I will know АЗЫ (azy) (that is IMAGES), which are the beginning of all beginnings".

Азы (azy) is the beginning of the ability of creating. Or: AZЪ (az), Боги (Gods), Веди (know) – I know Gods, that is, I have the knowledge of Gods. Or: AZ – the beginning of the path, Gods – the continuation of this path, but at a another level, that is, in the Heaven. Vedi – a unity of heaven and earth into a single holistic knowledge.

The Alphabet: A, B, C and so on – is a simple reading, accompanied by a phoneme sound. A simple reading gives us only the sound of names and a description of objects, phenomena – and nothing more. Now pronounce the letters: A, B, C. Is there any meaning in them? Nothing. These are just sounds (phonemes) – and that's it. A phoneme is just a sound background that does not contain meaning. The semantic meanings are contained only in the Images, which are the result of the union of thought with the source of life. **The image transmits information and shows its meaning in symbols – letters-images**. When considering the structure of the

alphabet and azbuka, it is easy to notice a similar order of letters in them. As you can see, the difference is only in the presence or absence of images in the letters.

AZЪ, Buki, Vedi and so on – is the figurative name of the letters that make up the azbuka of the mental language. ***The mental language is a thought-shaped language, that is, a telepathic one.***

Буква (bu:kva – letter) is a symbolic expression in the form of a sign. **BÜK-VA** – the creator of symbols. **BÜ-K-VA** – containing the created symbol, transmitted over long distances. **BÜ-K-VI-TCA** – a letter containing an image-name and meaning that can be transmitted over long distances. As you can see, the words БУКБА (BÜKVA) and БУКВИЦА (BÜKVITCA) have significant differences

The basis of the Russian language is **LOG** – (syllable). **LO** is a whole, homogeneous, **G** is movement, an action. **LOG** is the fulfillment of actions leading to a single, whole, homogeneous, which is part of the whole. ***Etymologically***⁹⁹, the word LOG derives from the Greek logos (teaching, science, word, concept, reasoning, mind, thought). The word log-i-ka (logic) means: **i** – the center, link, **KA** (at the end of the word) – movement from something. It turns out – movement from something to the whole, to the center. That is, logic is doing some actions on the basis of the complete, whole knowledge, reasoning.

The initial Russian language is a **SYLLABLE LANGUAGE**. In **Russian** syllable is **LOG**. Each log (syllable) has its own meaning and image. The word Logia is a description of an image and studying the purpose (meaning) of an object or phenomenon. When we connect **LOG** with something, we get **S-LOG**, that is, a linked LOG. ***The word is a number of connected LOGs.*** Each word carries information about the object voiced by it. The inner meaning of words reveals the meanings of those concepts that they voice.

It should be mentioned here about ***Imageology***¹⁰⁰ – the oldest science about the images of the mental language, the true meaning of the word and its figurative components for understanding the true nature of words.

⁹⁹ Etymology (dr. Ἑτυμολογία from ἔτυμον – truth, the main meaning of the word and λόγος – word, doctrine, judgment) is a branch of linguistics that studies the origin of words, their initial structure and semantic links. The term was introduced by ancient philosophers more than 2 thousand years ago.

¹⁰⁰ **Imageology** is the science of the true meaning of a word and its figurative components for understanding the true essence of speech, expressed in words.

The knowledge of Imageology allows people to use telepathy and communicate at a distance without words. For the holistic idea and understanding the world, Man needs knowledge of not only fundamental sciences, but also of imageology, etymology and linguistics. We are all familiar with linguistics and begin to learn it at school, studying letters, spelling, and so on. It is not that good with the etymology of words, but at least people have some ideas about it. And as for Imageology – complete ignorance. Imageology is the oldest science about the images of the mental language that our ancestors used.

Let us recollect a story from the Bible, which says that once all people spoke the same language and understood each other regardless of their place of residence. And then they decided to build a tower to the heaven to make them known, that is, leave their descendants the memory of themselves. They began to build the tower in Babylon. God did not like this idea and to stop the construction he made so that people could no longer understand one another. They began to talk different languages. This led to the fact that no one could finish building the tower, people scattered around the world and everyone settled in accordance with their own dialect. What does this tell us? This means that once there was **ONE INITIAL LANGUAGE FOR ALL PEOPLE**, for example, Russian, which was spoken and understood by all people. And then it was separated into dialects and people ceased to understand each other. «Well, what's wrong with that?» you may ask. It seems to be nothing special.



But looking deeply into the subject you begin to comprehend: ***they used the same language and understood each other, regardless of their place of residence, that is, people communicated telepathically, knew and used a Universal mental language of images.***

8.7. One for all...

One language for all means: Thought plus Image is Word plus Speech. In the material world – **LANGUAGE IS THE WORD** expressed with speech, which is what linguistics studies. In the world lying beyond the bounds – the other world – **LANGUAGE IS THOUGHT PLUS IMAGE** and this is studied by *imageology*.

Thus, before the construction of the tower in Babylon, people were fluent in a single language that included both of these aspects. As soon as the attention of Man switched to the material values (to exalt oneself, to make a name for oneself), Man began to lose the **IMAGE component** of the single language, which brought to its separation into many dialects. One language was shared for all: Thought and Image (*imageology*) were separated from Word and Speech (*linguistics*). Therefore, we are now using Word plus Speech and **CANNOT COMMUNICATE either telepathically or with the "beyond" World**. Without *Imageology*, it is just impossible.

To put in good order the meaning of words, there appeared *etymology* in linguistics. Etymology gives an idea, a concept of the word origin, which makes it possible to fully reveal its image. Since many words were borrowed from other languages, it would be right to first find out their origin, and then interpret its image. Modern science does not teach to know and understand the images of words. Why did linguistics forget about images? From the perspective of new knowledge, it is not difficult to understand. Etymology is a non-figurative, stripped-down version of imageology. Why is this so? **Firstly**, the



Greek priesthood was taught by the **SLAVIC PRIESTS**, who had deeper knowledge, and the Slavs passed this knowledge to the Greeks **in an intelligible form for their understanding, adapted to their culture**. **Secondly**, the Greeks **COULD NOT PERCEIVE THE IMAGES**, since they were not part of their culture and language, so they transformed the image system into etymology with the addition of the

meaning of the word to the origin. Therefore, etymology is a Greek (non-image) version of imageology that has come down to us. ***But few people think about it.***

IMAGEOLOGY IS AN INITIALLY RUSSIAN word. It is an integral science of Slavic priesthood. Imageology is the science of thinking in images, which gave form of words to the images to describe phenomena, preserving their meaning and essence. ***Man should not think in words, for this there are thoughts and images that allow everyone to have absolutely everything that man can imagine.*** But most often we do not know about this, therefore we do not use this possibility granted to us by Nature. However, those who are using **the "SvetL" Technologies** begin their relationship with thoughts and images. This is the beginning. These are the first steps to deeper knowledge of the world around us.

Another important difference between etymology and imageology: **the first** can be distorted by changing the meaning and history of the word, which brought to a substitution of concepts in words, but **the second** is **IMPOSSIBLE TO BE DISTORTED**, since the image is the result of the interaction of thought with the source of life – the Life Support System and those flows of information which are never interrupted. ***Etymology*** is an intermediate link between imageology and linguistics.

We know the **WORD EDUCATION** (in Russian it is derivative of **IMAGE-CREATION**). Nicolai Morozov, Nicolai Levashov, Sergey Danilov and, of course, Alexander Khatybov proceeded from the following perspective – the concept of education (making images) includes the process of creating images out of thoughts, rather than, as is now accepted, getting a diploma in a specialty. ***Diploma***, in Greek, means – a folded up written document. As you can see, the Greeks meant getting a diploma, and we began to call it education. It is just impossible to get education in its true meaning, without the knowledge of image formation. Therefore, now they say: ***with a diploma, but without education.*** And this is true. It is only a pity that not everyone understands this correctly. A person cannot be Educated, without the knowledge of Image-formation. Image creation. Getting a diploma is just a confirmation of the certain knowledge given to a certain person. A diploma does not guarantee possession of any skills or abilities. Imageology helps to broaden the horizons of consciousness, that is, it gives understanding and knowledge of the nature of phenomena and objects that come into contact with us in one way or another, as a result of which the horizons of our perception and knowledge expand.

Now, I hope that the readers themselves can see the variety of all kinds of human speech sounds, which can be depicted in print by making appropriate systematic transcription on each of our few basic signs. Such a scientifically developed alphabet, (according to Morozov) is only a dream, but until this dream comes true, ***we will not have scientific comparative linguistics and anthropophonics***, as there was no arithmetic before the invention of the system of uniform representation of all possible numbers in few digits, and the multiplication table was not known. Human linguistics would not stand firmly on its feet, because instead of following the shortest and direct way in its research, it would have to go along winding paths. We have already seen examples of modern attempts to solve this problem with ordinary alphabets. Whatever dots, dashes, caps, and hooks we cover up our random alphabetical characters, we will be confused in this area as well as in arithmetic, while every nation tried to depict numbers with different letters of their alphabet without any system. In order to successfully go on a long journey of some complicated scientific research, **IT IS NECESSARY TO HAVE**, besides a horse, that is, a representative of the persistent individual labor, a suitable harness, otherwise we will look like a traveler who is sitting in his old tub and is riding in it into the thicket, holding his horse's tail with his hands.

Modern comparative linguistics, that is, the various versions of our contemporary ABCs, is **NO GOOD** for human studies, because these options were invented quite by accident – each system is only for a given language,

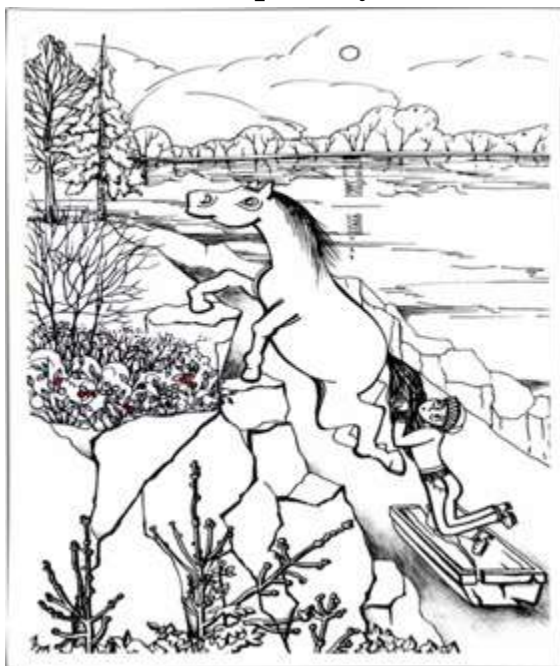

and not for all the languages, which should really be a scientific system. Of course, it would be best to establish a systematic alphabet by the all-nation congress, but experience has shown us that this machinery is too cumbersome and, like any collective, has great internal friction. ***Almost all great transformations were made by personal initiative***, which, if they were really expedient, were accepted, then, little by little, by the whole cultural world. It could be completed here because the science of the human speech sounds is incomparably less developed, and yet **IT IS EXTREMELY IMPORTANT** for the ancient culture rational study. Without it, it is

impossible to find out, for example, why most of the biblical and gospel names and ancient words were transformed, sometimes beyond recognition, when translating to other languages. And this was done obviously for the far-reaching plans – the development of the Brain genotypes within the framework of the old Control System, as you already know.

8.8. Where should we go in order to know?

To clarify the question, "whether was there a word in the beginning and who it belong to...", you should first understand, **WHAT DOES A HUMAN MEAN?** Of course, the answer to this question should be sought in science studies. Science, as such, is *a collection of the truths about our world*, and these truths should be divided into the physical truths and those related only to the human society. Well, as for the fundamental objects and laws of all science they are studied by philosophy. Indeed, in the reference books in the section "Philosophy" it is said that the number of "ultimate philosophical questions" includes the question: *"What is Man?"* So, then we don't need to go too far – right there, from the philosophers, we will find the answer. We go looking for philosophers and see that the places of philosophers are occupied by the so-called "political scientists." And we are convinced that, in fact, it is useless to look for an answer to this question – they, like all other specific questions, always have *blah-blah-blah* instead of a specific answer. To continue the search we **GO** from those who have to deal with general issues, **TO THOSE** who are engaged in particular ones. That is, we have to go into the depths of science – first to physics. Physics is a collection of all facts and all the laws of the material world, however, physicists do not consider the question *what Human is and what he is for* – they believe that this is not their business. In the best case, physicists just don't see where their work is – they don't see what exactly they should study. And as for "The Word... and what was in the beginning" – **THAT IS OUT OF THE QUESTION.**

Thus, the views on man existing in modern science are driving us further – to that part of physics, which is called chemistry – to the knowledge about matter transformations in the material world. Let me remind you that the field of chemistry research is limited to the transformation of whole atoms (as you know, chemistry is no longer interested in what an atom consists of). However, general chemists also do not see in the question "what is Human?" what could be the subject of their research. And, from chemistry,

we finally «come» to biochemistry – into that part of chemistry, which is obliged to study what life is by its physical nature and, accordingly, what Man is by his nature. And here is a dead end. Since the thought of researchers today about "what is Man" and "what was in the beginning..." is concentrated only in this section of science, then Man, according to the notorious «scientific community» (the community of those who live on science), is just atoms! This is just chemistry with the prefix «bio», and no physics, or anything else! It seems that fundamentally the knowledge of man is developed, and biochemist researchers work in this field. They have been working for a long time and painstakingly, but the question **WHAT MAN IS**, who also uttered the «word», remains unanswered. However, since quite a number of people were paid for the search for the answer to the question "what Man is", by now there obtained a lot of facts about Man, however, these facts have nothing to do with Man, and even more so – with the "word" – they do not clarify in principle. They don't even clarify how, who by, what for and why the body of Man is built and functions, Man having a "speaking tool" that is able to pronounce a "word". Until now, the question remains unanswered how life itself is structured and functions.

Why is there such a low result on the most important issue for humanity? The answer is simple and lies outside the scope of scientific research – ***the low result in the knowledge of what Man is*** lies in the fact that the majority of those who professionally search for the answers, that is, on money from the budget or sponsors, **ARE INTERESTED NOT IN THE KNOWLEDGE OF THE TRUTH** about our world, but getting money from budgets and from sponsors. The masses of grant-eaters are not even looking for the answer to this question, and rare enthusiasts are just disoriented by the framework of their narrow specialization. But at least in passing let us look at those who are engaged in science, and first of all, at those who we started from – "philosophers" (political scientists). People who called themselves philosophers, in the past centuries, instead of knowing the world, turned their activities into entertaining idle people with absurd chatter and began to divert from the practical tasks of philosophy, to move off from the philosophical analysis of the facts developed by other researchers of the real world. Philosophers turned into the field of abstract empty vacant philosophizing. This brought to the fact that philosophy of our time is transformed into political science. Today, political scientists (philosophers) **ARE CHATTERBOXES**, whose chatter no one needs in the real world. Judge for yourself, what kind of researchers of the general laws of the world they are if they do not know any details of this world? Most of

all, they like to be mistaken, because it relieves them of responsibility. And the facts cannot be trusted, because it is not known whether these are facts or not. But if a question arises, everyone goes into Wikipedia and there they can find information that, however, has nothing to do with the truth. However, another question immediately arises, namely, what we consider to be true? Was the battle at Kulikovo or was not? We can find people who say: **it was not and all this was invented**. Moreover, these people are professors with a good citation index, and they are good honest scientists, they just look at this subject from another side. And if this is a serious prominent scientist – he is a professor, or even an academician and he has wonderful works! But at the same time, what he is writing now is doubtful. Where to go then? Let's go to the Master Creator (you can call him God, and you can call him another way – as N. Morozov called.

So, – in the beginning was the Word...

But perhaps, it was another way? **In the beginning was the Thought**. The word came later **when the Thought showed its complete failure**. Don't you get it? Then let's make it plain – and as part of N. Levashov's work **"Tale of the Fine Falcon"** – I will make it clear.

There "came" Master to the Earth. He walked around and around and realized that something was missing and decided to create Creature «in his own image» from improvised materials. But mainly – from dirt – it turned out to be at hand – and out of it he created. And there's nothing to be done about it. It was later, when Concepts appeared, dirt was tactfully called Earth, Clay, Silt... **BUT DIRT – IS DIRT**. **And it was out of it that the Creature was created. Only One, but in a variety of guises and instances**, and, as we already know, within the framework of the planned "cultivation" of a certain Brain genotype. Master, creating it, really thought that he was creating new Selves. He needed them, because in Them He hoped to live on – in the new world and in the new hypostasis.

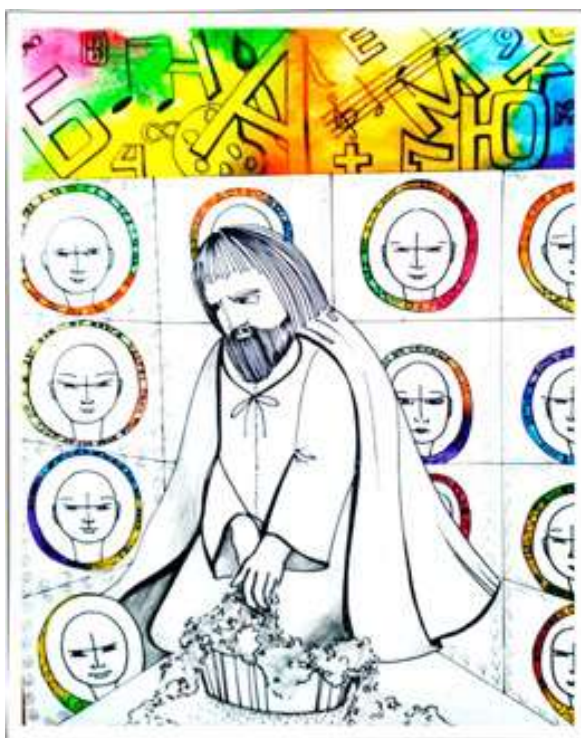

But – either there was something wrong with the initial material, or **SOMETHING ELSE NOT TAKEN INTO ACCOUNT** interfered in the process of preparing the initial brew, but it **WAS NOT WHAT** Master had hoped for.

No, outwardly it was the same, in his own image, but in its nature, the initiative could be safely recognized as failed. The Creatures lived, thought (mainly about the meaning of being), lazily exchanged their thoughts with each other and... that's **all**. They didn't do anything else. Master tried to understand what the matter was. The fact that the Creature had such a high thirst for self-knowledge was wonderful, of course, but where was everything else? And most importantly – where was the thirst for creativity? Unable to find the answer, He decided that in the original brew **THERE WERE** some **INCIDENTAL INGREDIENTS**. Or, on the contrary, it **WAS NOT ENOUGH of something very important**.

Master was too lazy to make something anew. He did not like to redo the work that was done before, so he decided to give "crutches" to the Creature, hoping that in the process of self-development these crutches would be thrown away. ***And the Word became the first crutch...***

At first the Creatures did not know what to do with the Word. They touched it, rolled it, tasted it, and, in the end, they ***turned it down as quite useless***.

Master was not surprised: after all, transmitting the Thought directly is much faster and more convenient than first wrapping it in the Word, and then conveying it to others.

The Thought was the root of the original problem! And Master decided to **REPLACE THE THOUGHT WITH THE WORD** temporarily, only temporarily. Surprisingly, nothing terrible happened. The Creatures rolled and rolled the Word and began to use it. With every day they did it more and more skillfully.

First, they wrapped everything surrounding them in the Word, giving it Concepts. Then the turn came to processes, then to actions, then to motivation. And then the Creatures **WRAPPED THEMSELVES IN THE WORD**, completely replacing what *it was given for to them* by Master in the beginning. Master got surprised when he saw what the Creatures could do with the Word. But, in some sense, there was an element of creation in this: ***The Creatures created by Him told lies every second making up***

new, previously unthinkable realities. And the LIE, using the Word, completely replaced the Thought.

Master decided that, most likely, He **HAD DONE SOMETHING WRONG** and wanted to correct what He had done by returning the Thought to the Creatures. But the Creatures refused the gift, not wanting to change the familiar and already possessed for the long-forgotten and seemed unnecessary.

Realizing that **HE FAILED TO CREATE** anything «in his own image», Master decided to have another try, but in some "other place", hoping that in that «other place» the initial material would be better and nothing superfluous would be mixed in the brew. And the most important thing is that **QUITE RECENTLY** Master was helped to be determined with that «other place» by other, more experienced Masters who knew what «his Creatures» were and how they would have to make (remake) them into Humans who knew what the Word was.

8.9. "Batteries" replacement

Language and word pierce all aspects of human being. Whatever we do, we inevitably use the language. We use it to communicate, to express our feelings and not only. Unlike all other living creatures, Man can speak and is able to learn other languages that are used in this world by people. Let me remind the readers that a detailed analysis of sound forms, if anyone becomes interested in (I'm sure there will be some) is given in ***the monograph "Christ", Volume 3 by N. Morozov***, which, as it turns out, is not even known in «the scientific circles». However, the reason for the formation of coherent speech and the ability to learn other languages is not clear to modern science. But there is also **NON-SCIENTIFIC POINT OF VIEW**: Each human's Brain has a "Translator", that is, a way to translate musical series received by the spine octaves, or stored in operation or long-term memory. There can be several such translators. Without such a translator, you can learn a language for hundreds of years with no result. If there is no translator, you cannot make your Brain learn an unfamiliar language. When reincarnation was in force, it was possible not only to transfer records of events that happened to the portable Brain, but also to transfer the translator, which made it possible to quickly and easily learn an unfamiliar language. It used to be. Nowadays everything takes place some

other way due to certain circumstances that are already known to the readers.

The new Control System, when controlling the Brain, checks the translator's correct operation and, if necessary, supplements the Brain (increasing the frequencies potentials) with "instructions" for changing the ionic part (shirt). With the frequency potentials' decrease, you can forget everything, lose your memory. As an example, is a well-known method of studying a foreign language in sleep. In fact, it is necessary to use the **8-series musical notation (see ch. 7), and not 7 (12)**, as is customary now. In addition, the recording must be done in the corresponding octave (the maximum possible frequency of the radio equipment is **octave 16**, which is not enough to form the command magnetic impulse potential). Instead of accurate "requests" to install a translator from the language, we currently have noise effects like "a crowd talk", and the Control System can only either increase the potential densities of the abilities given earlier, or remove them at all (you wake up and find that you have forgotten your native language, and there is no any other). It happens today...

With the density of potentials' increase, there might be the effects of the language knowledge (not immediately). This happens at the level of individual Consciousness of Man, but, as you already guessed, not every man.



From children's humor:

- Granny, are you having a headache?
- Yes, I am
- So, your batteries are dead.

Consciousness, from the standpoint of "***field physics***", is the formation of associated Brain neuron connection schemes with the governing participation of gravitational processes. That is, Consciousness has a gravitational basis in general, and the formation of its elements is arranged on the basis of field physics.

What, then, is the material carrier of some energy matter that is different in its nature and point, moving in the different Brain neuron connection schemes, emphasizing the fact that there is no any simplified

stereotypes in these processes, because with the help of such movements a certain amount of specific address information is transmitted, which are **EXTREMELY IMPORTANT** in the general or particular cosmophysical processes of our flesh cells being, supporting or executing some control processes and functions of our Brain, especially those related to the formation of our Consciousness' elements and so on. The physical basis of the entire complex of the specified realizing processes is **FIELD PHYSICS!** And the material basis, as the carrier of energy matter, which forms the entire realizing basis of field physics, are the primary and secondary flows of the **MAGNETIC ENERGIES MATTERS** of different parameters, as the basis and guided flow of **THE ELECTRIC ENERGY MATTERS**, which do not contradict each other due to the difference in their parameters and their physical nature, even going and intersecting in the same neurons patterns. The secondary cosmophysical processes of different levels are the Brain formed conditions for the life support and life providing of the flesh cells and the formation of the elements of Consciousness and the structural elements of the Mind under the new Control System's conditions for the civilized development of our Earth.

When realizing the physics of this process, it becomes possible to puzzle out some deeply inexplicable and hidden sacrament participating behavior from the epiphysis and its effect on many functions in the human Brain – (like a kind of "third eye").

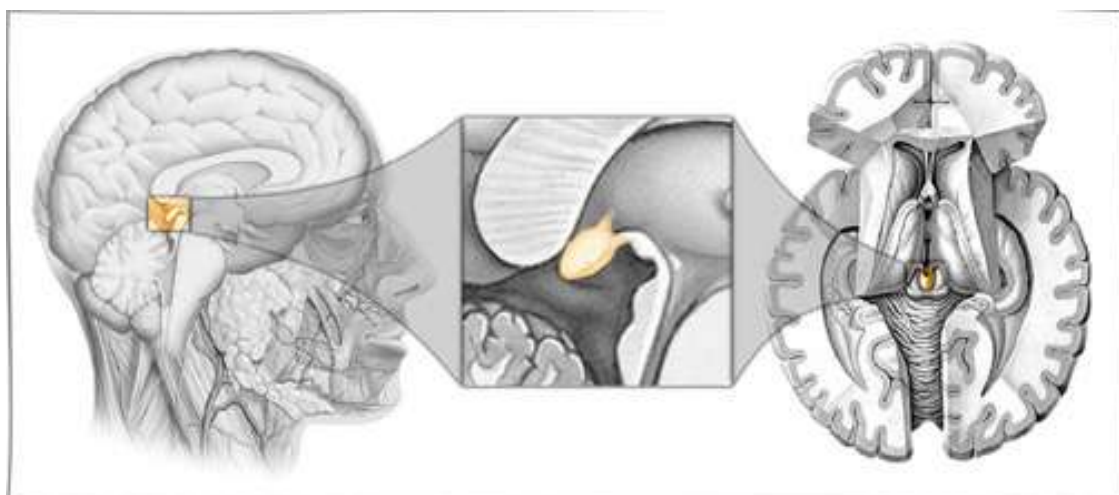

It turns out to be one of the Human Brain's gravitational states regulating control centers. It is **more functional at night**. An interesting "coincidence": Exactly at the same time an active process of all "reinstallations" of various control programs takes place, carried out under the control from the outside (from various Earth Control Complexes, etc.), including such program processes of changing the material flows carriers of

ELECTRIC AND MAGNETIC ENERGY MATTER, as a "preparation" for future processes of receiving "**energy-information**" *from outside* due to the changes of some external influencing character (partly from the Earth Control Complexes). And here I would like to emphasize the fact that **«energy-information» is part of the magnetic energy matter**, but **POSSESSING THE CONTROL INFLUENCE** only on the living substances behavior and being and its life support elements (as opposed to «energy-time» influencing the inert matter).



Today it is particularly important to consider it when «locating» people in the territories. Moreover, now the territory and the people living in it are **SEPARATE FROM THE STATE**. All this is related to the processes of the program's correction in the implementation of the transition period. This is briefly about the controlling gravitational processes realization with the participation of each individual's Brain, and even more so of those who consciously used the "SvetL" Program for the formation and development of their individual Consciousness. This accounts, for example, for my "work" in restructuring Programs, adjusting the generator and other related things at "night" time and building up all Programs and their supporting processes, based on the fact that "energy-information" is the energy with its own material carriers. The carrier is a magnetic particle that can be created (if, of course, you are able to) both in the material and non-inertial states. The behavior features of material carriers in neuron connection schemes are defined as a complex of Cosmo-physical processes under the controlling

influence of gravitational nature. One of the carriers of these Programs, as I have already mentioned many times, is the Generator created by Nicolai Levashov. For all that it should be taken into account that in the process of gravitational interaction with the Human Brain, there are both – the "energy-time", as the level of interaction of the primitive, organization and control of heterotrophic states in the sphere of flora being (the SvetL-Flora Complex), and "energy-information" at higher levels of interaction, control and self-organization (possessing the Human Brain's certain functions and direct interaction of the Brain with the Programs that are linked together in the "development and recovery" program). The knowledge of this solved the problem of the comprehensive and versatile use of the Programs through the **RECENTLY CREATED "GLOBAL PORTAL"**, making it possible for the people allowed there directly and, very importantly, through their "SvetL" Complexes, which now do not need to be "modernized" and "reprogrammed", due to the processes in the Life Support System of people, more efficiently and guaranteed solve "their health problems" and their Brain personal development and rising its octaves, taking them away from the consequences of the Old Control System and, naturally, more effectively improve their physical body (shirt) and the Brain. To solve this problem, quite a significant amount of time and experience in time was required, but today it is solved. This conclusion is already far from fiction and is confirmed by the practice and results of the Programs use and their long-term effectiveness and the current results of the "portal" activities.

Initially, N. Levashov explained all this to me, and later I got confirmation of these processes in the works and calculations of A. Khatybov, and A. Luchin, which were applied and realized. These very general conclusions that I brought here were formulated by me so that people would find their feet in the new reality. Each step in this direction requires a lot of work. For me these steps were complicated by psychological difficulties both in me and in people who took my word for it, but nonetheless kept firmly to the path of cognition, due to the unusual nature of the phenomena (ideas) that were opening before them. and I felt specially responsible for the reliability of the results which I published both in the articles and in the books. I have been always believing that changing ideas **DOES NOT MAKE MATERIAL** of the previous stages **DEPRECIATED** in comprehension upon reaching the next more advanced, therefore one of the tasks that I set for myself was to review all stages of research, and even more so, the results of their practical application .

After reading this chapter, I hope the reader will make his own conclusion "...what was in the beginning..."

the ordinary to see how it is applied for its own purposes. And here it depends on the thirst for knowledge. The truth exists even when it is not recorded and not spoken, and not realized. Regarding this eternally existing Man can get false and true knowledge. The former in its very nature is mutable: it is either replaced by other false knowledge or disappears when true knowledge takes its place. The latter, by its very nature, is unchangeable: because there is **NO OTHER KNOWLEDGE** that could replace it.

Thus, **TEMPORARY KNOWLEDGE**, which either, being true, is of a temporary object, or being of an everlasting object, is false. While **EVERLASTING KNOWLEDGE** is both true and is of an everlasting object. Only the latter forms science; this requirement is also stipulated by the fact that the content must be permanent.

Now I want to say about what is meant by false and true knowledge. And in my opinion, this should be said precisely in this afterword to the book. ***False knowledge is the one that is improperly formed; true knowledge is the knowledge that is formed correctly, that is, in line with the nature of the Mind.***

In all cases when it is possible to compare the knowledge with the object of this knowledge, we notice that the false knowledge does not correspond to its object, and after looking into the reason of this discrepancy, we always find that it is in some kind of deviation made in the process of the knowledge formation; so by removing this deviation, we restore the identity of the knowledge and its object, and by increasing the deviation, we increase the difference. True knowledge corresponds to its object, and the reason for this correspondence lies **IN THEIR FORMATION CORRECTNESS**, since as soon as the latter is violated, the first is destroyed. But one should not think that the truth of knowledge depends on its correspondence with its object or that this correspondence is the truth; because there is a lot of true knowledge, the correspondence of which with the object we are not able to check, and among them there are some which we probably know that in reality there is nothing corresponding to it: for example, all knowledge of imaginary quantities in algebra. There is no doubt that they are true, no doubt that they are not a copy of anything observable. But this is not the only case when the "true" cannot be defined as "corresponding to the real"; but also, because the truly realized is broader than the truly existing and the world of the human mind is wider than the world lying outside of it. So, the true knowledge can be not only of the existing and what this knowledge can correspond to, but also of what that should exist and what this existing

should correspond to. These are all the truths in the world of moral and political ideas. Neither their formation, nor the desire to be improved and improve one's lives could have arisen in Man if his knowledge was limited to the existing. Thus, between the three properties of knowledge: the correctness, truthfulness, and conformity with the object – there is such a relationship that the first determines the second, and the second determines the third; but not the other way around. Knowledge is true and correct not because it corresponds to the object; but it corresponds to the object because it is true, and it is true because it is correctly formed. Therefore, when the first property undoubtedly exists in the knowledge, the second always exists, too, and the third – when it can exist. As for the correctness of the knowledge formation, as already mentioned, it is in line with the **NATURE OF THE COMPREHENDING MIND**. All this, of course, should be investigated separately – in the Doctrine of Cognition.

But out of the true knowledge, not everything should be accepted and studied today, but, in my opinion, only the knowledge that is directed to **COMPREHENSION FORMATION**.

Nowadays many people believe that knowledge and comprehension are the same thing – *if there is knowledge, there is also comprehension*. But this is far from the case. Knowledge and comprehension vary in nature and origin. The first is limited to the simple awareness of the object existence; moreover, none to the questions that can be asked regarding this object is resolved and, as far as the pure knowledge is concerned, such questions are not even raised, since raising questions beyond the simple existence, and the desire to resolve them **IS THE TRANSITION TO COMPREHENSION**. The latter, however, contains the awareness that the existing cannot but exist; moreover, all the questions that can be proposed regarding the object are resolved. The first is limited by the external signs of the existing and the outward forms of the happening – those signs and forms which are attainable for the sensory organs, as N. Levashov wrote about this in every detail – but this knowledge is superficial. The second reveals what lies under these external signs and forms and what produces them, that is, brings to understanding the internal nature and structure of the existing and internal process that occurs in phenomena – **IT IS NOTABLE FOR ITS DEPTH**. The first is fragmentary, incoherent: it does not combine various phenomena into one whole, inextricably fastened by an internal causal tie. The second is integral: it clearly sees individual phenomena in their mutual connection, as well as the whole, the parts of which make up these phenomena. Therefore, for the

first – everything is random and inexplicable. For the second – everything is necessary and clear.

The very origin of knowledge and comprehension is different. The first is formed in man, because he is gifted with the senses, as I mentioned, his mind remains passive. And, since the sense organs are identical for all people, knowledge is equally attainable to all of them. Comprehension is formed with the **LEADING PARTICIPATION** of the human mind, and external feelings are only tools for it (the mind), which it directs and the impressions of which it explores in order to reveal what is behind these impressions and what causes them. And since the minds of different people are not the same, comprehension is not characteristic of them to the same degree: there are separate people and even whole nations, almost completely devoid of it; and there are nations richly gifted with them. Why is that so? This is where we should use our knowledge and comprehension. The answer is in three words – the Brain Genotype...

Based on this, there is only one conclusion – ***there is a sharp and deep difference in the development of knowledge and comprehension: the first*** increases through a simple mechanical addition of some knowledge to the existing knowledge; ***the second is developed***, becoming deeper and fuller. Every piece of gained knowledge is enclosed in itself and does not necessarily cause new knowledge. Any gained comprehension acquires this closed character only after it becomes perfect. Before that, it necessarily raises questions in the mind; it remains as if open for bringing new, explanatory and complementary knowledge. The truths in which knowledge is expressed join one another and **ONLY IN COMPREHENSION THEY ARE UNITED**. I also note that knowledge comes out due to some reason, and comprehension – due to some purpose. The first is unconsciously and indifferently assimilated by Man thanks to the very structure of his body, capable of perceiving the impressions of the outside world. The second is striving for comprehension of what is already known as knowledge.

The totality of human knowledge is an endless reflection in his mind of that endless series of phenomena that passed before him in time – unchanged reflections and mysterious phenomena, in the creation of which he has not participated and by the power of which he or more precisely, his Brain is enslaved.

Human comprehension is a separate complex and profound world, created by a human thought, slowly and relentlessly weaving threads, the last

pattern of which is unknown, but which contains the last clue to everything. In this world of ideas, always motionless in their foundations and always developing by means of inner self-opening, their great creator, the Human Mind, lives and dominates, which, in fact, is the subject of this book. And this world **DOES NOT REFLECT ANY LONGER** the phenomena that are passing by: it penetrates into what lies behind them and which, while remaining attainable for thinking only, produces and explains something attainable for sensations.

That is why the **WORLD OF NATURE AND LIFE** is so clear to people with a rough mind and so incomprehensible for the people with a deep and subtle mind. Whereas for the former everything is already clear, for the latter everything is still dark; for the former, there is nothing that would not be natural and ordinary; for the latter, every ordinary phenomenon is full of mystery; the former live neither wondering nor worrying, the life of the latter is a constant wonder of the incomprehensible and worry of the unknown, the essence of which is inexplicable to them, but the existence of which they firmly know. From



this follows some mental indifference of the first and the thirst for knowledge of the second. Only those who follow this path are ready to “be surprised” and show anxiety after knowing that ***the Russian language (as well as English) was "developed" 257 years before the birth of A.S. Pushkin***, and from now on the frequency balance of living cells and bone resonators has been changed for the new structures. Here I repeat myself to make the previous chapter and some of my articles easier to understand. I am sure it will be useful for everyone who is able to "be surprised". What is the peculiarity of the Russian language structure, or the language intended for subsequent use as a means of communication with higher civilization? No other language can describe the musical series of ***the Shukhov tower, designed for the objects' (UFOs) exit to work***. 33 tower supports are consistent with 33 heroes in Pushkin's poem, 33 years (the time interval according to Meton). 33 letters (even after reduction from initial 49 letters to 33) of the Russian language alphabet make it possible to describe **ANY NEW STRUCTURE** and have an analysis of any code sequence. These

changes were made throughout the Earth, but taking into account "local control structures", such as, for example, in China, Japan, Korea. The structure of the thinking process in these countries using hieroglyphs differs from the generally accepted one. This is the structure of images, and changes in this structure that are not characteristic of the stereotype would have led to the destruction of a significant part of the Brain matrices, which was unacceptable that time.

For about 200 years, the new alphabet was adapted in the environment of high culture and received a worthy continuation – ***on Easter 2007, it was the Russian language that became the only language of communication with the Higher Mind.*** And all the information is translated only into Russian. Now in America and Australia, and especially in Israel, they urgently learn the Russian language, but there is no time for adaptation there, therefore, none of them will be allowed to Moshiach¹⁰¹. In addition, representatives of Israel in other countries mainly have “dog names” (if translated into Russian), which is unacceptable and will be annihilated.

Previously, the publications almost never mentioned that in addition to the imposed 4XX Brain genotypes on the part of the “Interventionist” Earth Control System, there were **INDIVIDUALS with the brain genotype 384, most of which were settled in Old Russia.** From time to time, from the “Native Earth Control System” there was a **HIDDEN INFORMATION SUPPORT** of all spheres of life of this particular **genotype – 384.** ***The individuals of this particular Brain genotype were considered by the Interventionist System (Ebr) as the main material for the “practical application” under the Program “Development of Energy Biogenesis of the Flesh Cell», on which, basically, many experimental processes were tested.*** Separate functional and territorial endowment of Russia made it possible



¹⁰¹ In Judaism, the word "moshiach" allegorically means "king". The Jews believe that the ideal king, a descendant of King David, will be sent by God to bring about the political liberation of the people of Israel from the rule of other nations. In Christianity, the Greek form of the term "moshiach" is Christ, as well as the term "Savior". In Christian theology, the role of Christ the Messiah goes far beyond the concept of Judaism about the salvation of Israel and extends to all of humanity.

(unlike other territories) **TO KEEP WITH MINIMUM DISTORTIONS the Brain of people of genotype 384**. The most "gifted" part of those were the Vedas. It was for them and through them that the energy-information translation from the Native Earth Control System was carried out in such a "hidden" form that could be brought to the people at different stages of development. *The Vedas was not only the knowledge hidden in various forms, but also the people who brought the knowledge and through whom this knowledge was preserved. The same applies to the forms of information storage – with the help of people, on tablets, scrolls, in the form of some artifacts and other things. And they really existed and are existing at present time, which cannot but inspire hope that it is through them everything planned is being realized.*

That's the whole trick about those who are able to "wonder" today. It was through *the individuals of Brain genotype 384* that the Native Earth Control System saved the elements that allowed those able "to wonder", to approach the very truth about the "World Created". And it should be clear to everyone that taking into account the current level of the Brain development of a lot (majority) of people, with respect to each stage of the ongoing, such information has been presented more often in the object-esoteric world perception, or in a kind of demonic understanding, or some other particular forms, considering the territorial and functional endowment of a community of people, their "national" and geographic features. This is, actually, what we are coming across when gaining knowledge.

I do realize how **DIFFICULT** it is for our **CONSCIOUSNESS TO GET OFF WITH** the illusion that it somehow gives birth to all of this, finds or articulates its meanings in itself. It is all the more surprising for us to "discover in ourselves" the order of the meanings, concepts, forms, and the very worldview entering into our consciousness. And you should not stand still, "chewing" a certain piece of just known information. It is necessary to move forward in your experiments and try and push your results into the practice of people's lives, otherwise the cheating and lies surrounding us will go on prevailing over people's minds.

Today, the Russian language is adopted by the new System as the control and communication programming language. It cannot be commanding because of its redundancy. Of all existing languages today, it has the **HIGHEST DEGREE OF DENSITY OF INFORMATION SATURATION**. The translated linguistics uses a lot of words that have the

likeness of an Old Slavonic sound since it requires (especially for the information of the executive character) much **greater informational completeness of each word**. When reading texts on New Knowledge, there is some misunderstanding of individual words and phrases, some words seem elaborate and unnecessary, there are many similar words to the former Slavic speech, but this does not mean a mirror-like usage of it. We should learn to understand and use them. **IT MAKE NO SENSE** to simplify the translated language due to the fact that there is a distortion of the information perceived by the Brain. It rejects what it does not understand. The peculiarity of the Russian language is in its imagery, it is the most sophisticated in perception of the material and intangible images, in their world perception and, in this regard, it is the most vulnerable. It is powerful by the word, and vulnerable to the word! For this reason, one must be **MORE TOLERANT** and try to take the received materials without distorting the text. It really comes from the true Control System. Therefore, it is necessary to get used to it – this will be our new format of language communication.

People are far from what they think of themselves. Ascribing to themselves some high degree of consciousness and independence, emphasized by various absurdities from religious, atheistic, esoteric and other lists of gifts and abilities we unconsciously, only with this, **CONSIDERABLY RESTRICTED** even that small possibility of our own development, which despite everything remained in working conditions in some people. It's basically no different, for example, any publicly criticized average sect with a mandatory set of **a "leader plus followers"** flavored with some outlandish rites and obscure dogmas – and a narrow scientific trend – there is also a leader there that has to be respected and promoted; with the followers (lower and middle-level research workers), and quite outlandish rites and dogmas, which correspond to the experimental and theoretical parts of the scientific work. It is somewhat easier for science, because society must support it “morally” and financially, and sects are self-sufficient and censured by the majority. But the scheme of consciousness that worked for a man and that was given to him in the existing design **DID NOT ALLOW** more deviations, except for those allowed, which were manifested by the rich, by our standards, variety of available “social” constructions, reliable and invisible to the highly conscious, supposedly Man, in our opinion, **limiting any possibilities of real development**.

The simplest experiment, possible for everyone – when making the acquaintance in absentia, for example, when your friend tells you about a

third person who he is familiar with, to the question "***what is he?***" – the expected answer will be a profession in most cases. In a second place – belonging to a religious or financial group. These are all **OPTIONS** of the **EXCEPTED NORMA** – a man was successfully integrated into the system; he was its working material. Omitting the extreme options (criminals, drug addicts, alcoholics, etc.), we get a small remainder – a defect of the system – a situation where it is difficult to say about a man what he is. In most cases, he himself can hardly identify himself clearly for the people around, leaving them to decide on their own on this subject. In the closest approximation, it is about him that we can say – Man. And in the eyes of the people around, he will be incomprehensible and difficult to identify. This is the one who, for reasons that are not always dependent on him, has kept the state of the Brain more or less suitable for restoration over the past two decades. -And to restore to what level? – you may ask. To the possibility of achieving a harmonious contact state of his Mind with the Mind of the Earth. By this alone, I think, all interested and curious can easily remove all other questions, demanding some hidden or unknown secret answer. And while such a state, or at least a clear path to it, is not achieved, it is better to focus on one's **OWN PERSONAL DEVELOPMENT**, instead of "showing the way to the allegedly lost". ***It is not yet known – who is more deviated from the road – the one who is looking for the answers, or the one who offers answers, or even imposes them.***

Any firm point of view, no matter how attractive it could be and whoever it may be justified and supported by, loses with respect to the worldview **BEING FORMED INDEPENDENTLY**, based on one's own conclusions. Acceptance of any position, belief, whether due to respect, trust, or current (prospective) benefit, is a deliberately individual degradation in the broadest sense. The constant state of quest, excruciating doubts, disappointments and frustrations, some failures and other "lyrics" mean development, and only a small stage of it, similar to the teenage period in the astral jungle. If suddenly it becomes good and comfortable, and everyone around you are satisfied with you – it means – "you just wander off somewhere in the wrong place". Do not worry and calm down – the mentioned "lyrics of suffering and torment" do not last long, giving way to an emotionally clear look, which can partly be described as an "internal look from the outside". This is such a very functional and surprisingly convenient **PART OF THE CONSCIOUSNESS STRUCTURE** – one's own "internal observer".

Imagine, you started some kind of experiment. You want to check your own (or someone else's) judgment in practice – you thought it all thoroughly in and out, carefully calculated all the consequences and side effects. Realized. Everything turned out all right, the result was beautiful and convincing. It was wonderful. And if the result does not meet your expectations? I share experience – it's even better. This means – **NEW INFORMATION FOR COMPREHENSION** has appeared. This is already some kind of a new open door, the possibility of some leap in development. This means that you are faced with something new for you. This is something that Nicolai Levashov wrote about so "incomprehensibly" – new matters, new qualities... This is exactly – the **BRAIN DEVELOPMENT**. Such, at first glance, failure makes it possible to expand greatly both your own understanding and capabilities. When everything turned out right away – it's a confirmation of your understanding and skill, it's normal. ***Failure is moving forward.***

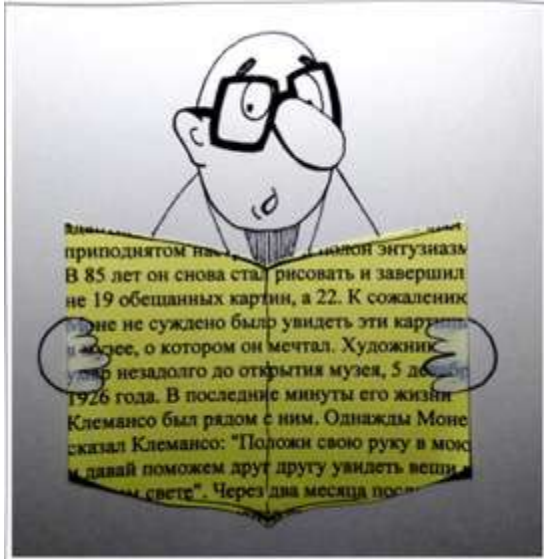

accelerating and expanding, drawing in absolutely everyone. You ought to keep your wits about you not to miss the opportunity. This is to ensure the accelerated development of the Brain of the Recreating Man, but on the condition that everyone is using and developing **ONE'S OWN BRAIN**, tormenting and straining it, and not trying to maneuver among someone's judgments. All that someone once said, even if someone is very literate and reasonable, recognized by everyone and so on, – it is all in the past, ***it is something that can be used and go on moving further.*** Any polarity of judgments, discreteness and narrow certainty **APRIORI SHOULD HAVE PRICKED UP ONE'S EARS**, regardless of its source. Discrete logic cannot give any deep understanding and development, the principle of its operation lies in the surface layer. It claims to be the truth, while being limited and primitive – having a two-dimensional structure while applying

to multidimensional ones. It is justified only as the most primitive option – **"to survive at all costs and not more than that"**. Human emotionality serves as a tool for such a discreet logic – the reaction to a stimulus (to something new) in a man is the more emotional, the more discrete. Emotions are a powerful limiter, blocking, first of all, the Mind and the possibility of understanding, and it does not matter whether they are painted white or black. The search for shades in your own emotional reactions is also a technique that allows you to unblock your own capabilities. Both wild delight and sincere indignation will successfully block anything given for understanding and sober appreciation. It is important to understand this, precisely in today's hard times. One of the options for accelerating the passing this "emotional" stage of development is an event load. Look, – in what "accelerated mode and all together" humanity all at once began training, in this regard, too. A great number of people in the created conditions have learned to take a sober look at things, use their own Brains and take their **OWN, NOT SUGGESTED** decisions.

Against the background of the obvious acceleration of the processes unfolding both in the open form, accessible and even intended for demonstration, and in the hidden one. It seems vitally important for any Man waking up from a dream to understand what is happening, **what had been done on the planet, and by whom**, to have time to understand how, why, and what for the Human Brain was transformed, find in the past



events the **GRAINS OF THE TRUTH** that could prove everyone the truthfulness of the information. All this seems completely appropriate, correct and justified, but all **CAN EASILY BE DISTORTED BY HASTE**. Hastily made decisions of any scale, ranging from insignificant at first glance to grandiose and ambitious, will be based on the old, distorted foundation of man, but not on Human thinking. The usual methods of decision-making, supposedly fair and even far-sighted, are based on the **LIMITED WORLDLOOK**. The habitual desire

to determine something completely and irrevocably, to take the side of the

right, to move away from evil and come to good – though it seems understandable, – is fundamentally wrong.

A changing and being changed world **CANNOT** be harmoniously combined with some constant, unchanging designs. Good and evil do not exist by themselves; it is as simple and complex as showing a child where west and east meet. Nothing will turn out if you are in a hurry – not only in trying to make a decision when striving to realize a desire, but even in choosing the desire itself. And isn't this what the old Russian fairy tales teach us, in which the stronghold of rationality and foresight is contrasted with the emotional and hot start – Gvidon, who wants now one now another, and Tsarevna the Swan, quietly waiting until the young man calms down and takes up his mind; a sober and reasonable Humpbacked Horse, who knows ahead and knows what the hasty Ivanushka does not even think about; equally impatient the old man and the old woman and calmly waiting for the right moment the Gold Fish... But they are fairy tales, cleared of half tones for discrete human thinking, but in reality, it is not that easy to figure out. As an example, I will cite the **MOST ACTUAL QUESTION** of many of my readers and not only of them at the end of this book. **HELPING PEOPLE in their health problems**, including in the context of their own development. That's where the haste sometimes leads to ambiguous results with the apparent obviousness of the opposite – ***if I could help, then everything is fine, good has won, all well done.*** The question is voluminous, therefore, we single out several points which is absolutely not recommended to do, since everything needs to be considered in context, but the laws and rules are not written for us, you need to know how to violate them, since, rules and laws are the best servants of discrete thinking, aren't they?

So, what should you do if you encounter a seriously ill person who clearly does not have any help from modern medicine, and you do know that you are able to help? Well, of course, a sense of justice, a thirst for heroic deeds, compassion, and awareness of your own abilities, triggered off with a delicious piece of ambition, are woven into such a powerful tangle that in a haste you are not able to untangle it, and the obvious solution would be ***to help "for good"***, and then come what may! And away we go! The first mistake – and who will ask what the suffering person thinks of all this? Perhaps he has never thought about what may go around him and where it may bring him to? Actually, the initiative **SHOULD COME FROM THE SICK PERSON** with his full awareness of what he is asking for. But ***such ideal patients do not exist in reality.*** Most of them, and I think you,

readers, agree with me, just suggest **"SOME MIRACULOUS HEALING"** like a wave of a magic wand or a few miraculous passes. Perhaps more knowledgeable patients count on some powerful cosmos-like effect such as frequency modulation, immersion in a magnetic field, or even a special state of the subconscious. People who are familiar with the works of N. Levashov are more clearly oriented, within the framework of their level of understanding, in the processes of correction – at least, they understand, that in most cases it is a **NOT A ONE-TIME** "procedure", that it requires for **SOME ENERGY SPENDING** and entails some deterioration in the general state of the one who does it. But you hardly find among such suffering people a person who is at least half aware of what this (influence/correction) is in general and how it all goes. So, in the end, there is just a great formality about this subject. The patient should realize what is going to happen to him if he wants some help from me, for example, but his Brain structure and the type of thinking **DO NOT ALLOW** him to understand it in principle. Therefore, no matter how many times you ask him whether he has any idea about what may expect him, his expectations never correspond to reality. Already at this stage, you can guess that ***all the blames and troubles will be aimed at me***, in the end, the sick, not understanding everything, even with the best results **DOES NOT UNDERSTAND WHAT HAS BEEN DONE**, what risks it could entail and what particular or global problems I could encounter. And this is not the worst outcome. Often the lingering nature of the correction (when I would like to speed it up, but it will turn out badly to the sick), causes bewilderment, doubts and the desire to add something else to speed up the recovery, forgetting everything that Nicolai Levashov wrote in his books, everything that I repeated in my books, ***people are in a hurry to use a variety of means***, trying to convince me and themselves that this will only enhance the effect of my work – not understanding, in fact, what this work consists of and how exactly the applied means are going to make it more effective. In connection with the above, the obvious decision of the “right” patient is to stand still and listen to me attentively – is, in fact, also not the point. Perhaps, the most desirable option for everyone – ***to obediently, correctly and enthusiastically do everything that is prescribed***. This is where there is room for imagination of psychics and healers of various stripes – the more unusual and sophisticated the recipe is, the more confidence the author inspires in the patient, the further the rumor goes and with it the recipe itself, ***sowing in the heads some awe and joy of saving from the torments***. And this, as you already understand, is an

EMOTIONAL COMPONENT, completely obscuring any attempts of the Mind to **SOW THE SEEDS OF COMPREHENSION**. An obedient, ready for everything sick person, most likely, will restore his health to a decent condition with the help provided and... remain a believer in his new "god", an obedient and ready-for everything devotee, without a hint of the ability to generate independent judgment. This is the best and most sought-after option for a sect, for example, which I mentioned above – there, the more devotees and followers, the better. However, this does not exclude that the word of mouth from such a person will lead to New Knowledge, and not to me, as a variant of health assistance, a couple of dozen "devotees", which is already more than good.

In general, there is no one universal solution. Therefore, in this, as in everything else, you have to look for your own solution and not for the set of ready-made options that worked for someone efficiently, but your own, true only and exclusively for you – and accepting it, be responsible for it.

It is a delicate question – why, in general, should I help people in their problems with health, diseases and more? It **TAKES A LOT OF TIME** that I could spend with undoubtedly greater benefits for everyone. For these problems there is already a solution in the form of the "SvetL" Complexes in different versions. As a result of the help, there are few who are completely satisfied – that is, they, of course, write about their sincere gratitude, etc., but the true state of affairs is not a mystery to me. Judge for yourselves, if I am able to correct the work of the Brain, which is possible only if it is clear what is wrong with the Brain, then obviously it's not a problem to diagnose less sophisticated parameters, not excluding the emotional component, which the majority's thinking is built on today, and the larger this component, the more health problems. And, mind you, a little in other words about all this, but in a similar context, Nicolai already said in his books, as well as about why and what for "...you should help not everyone who asks for help, but only who deserves it and is worth getting it..." Here is the answer to the delicate question above, and I am writing this so that you, the reader, decide who can determine whether a person is worth getting help. I do not urge to follow myself or to move in my own way, as if allegedly tested and reliable – ***I ask you to look for your own way.***

With this Afterword, I am finishing my fifth book, but this does not mean that the series of my works, which has the name "***N. Levashov's 'SvetL' Broom in A. Khatybov's Bath Science and a Labor Spade***" is completed. The story about the ongoing events, our future (as far

as possible), the **"SvetL" Technologies and new Technologies**, such as the created **"KNOWLEDGE PORTAL"**, about the Support Programs for these Technologies, **cannot be stopped**. Other Technologies, other Programs are already knocking at the door and will probably **GET NEW NAMES** related to people who have taken most active part in their creation



and development in our rapidly changing world. However, I'm sure that **the "SvetL" Technologies, the "SvetL" Programs** and the **SLN logo** (Svetlana-Nicolai-the Levashov) that covers it all **WILL ALWAYS BE THE FORERUNNERS** in the solution of the main problem that people have faced – quite recently – **to help correct all** that has been "done" to them over the past 2000 years on our Planet – in the broadest sense of the word "help"!

Reasonable orientation in the ongoing events is necessarily realized with the direct participation of Man, the development of his Brain states and functions, his direct participation in gaining the knowledge of the truth, the acquisition of a perfect Mind, and the constant development of the elements of individual and social Consciousness while raising the level of knowledge. Neither people, nor, moreover, modern science, have yet showed or set such an approach and awareness of its significance. This time has come.

AND THE LAST – **what can be public today** (unfortunately, not everything, due to the circumstances well known to the reader, **and extremely appropriate for the people who have taken the path of knowledge**, I wrote and recorded in this book so that later, after a while, the readers could return to the written and compare with the ongoing.

Having finished this fifth book, I am starting a New Project – the exposition of what I myself have known, tested and applied – what I want to convey for people's understanding. **This will be 369 articles, notes, essays and other forms of reporting, clarification of information and, possibly, recommendations in application and use. To this** I was roused by the sayings of Nikola Tesla: **"If you knew the magnificence of 3,6 and 9 numbers, you would have the key to the universe"**. All the information that I have today and which comes to me, the information that I gathered from N. Levashov, and from A. Khatybov, and from A. Luchin, and from other true Russian scientists who

have passed away and those who are now alive, I will wrap in the acceptable form for those thirsty for knowledge and will present it in my new project!

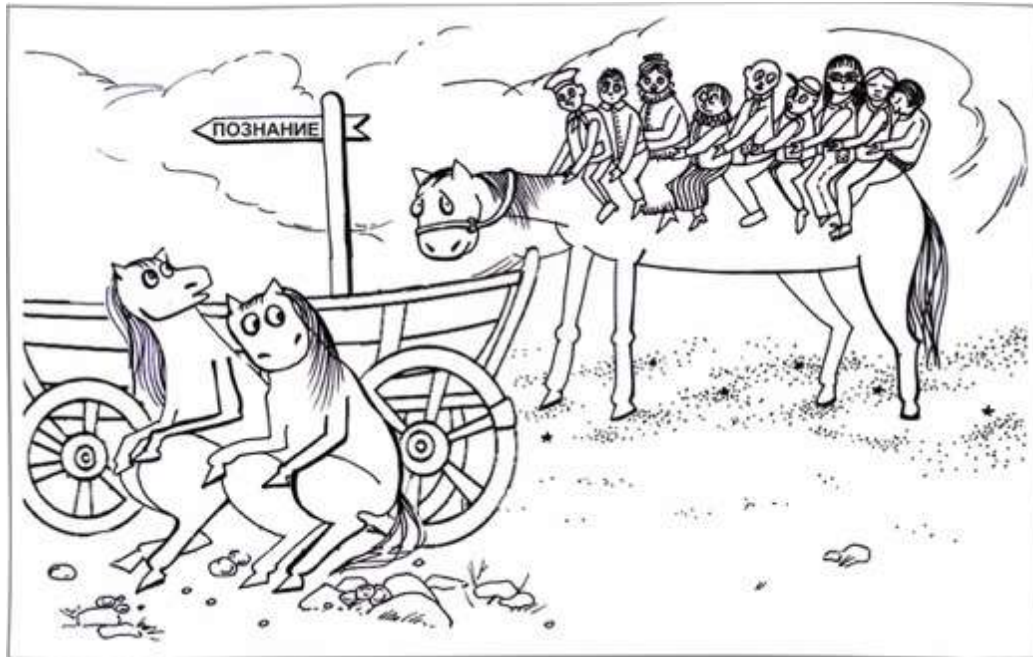

I will tell you why the whole world lived at the expense of Russia, why for the last 200 years Europe has been "prancing" on the money of Russia and its historical values. America also exists today due to the so-called "brain drain" from Russia in terms of developments and technologies that are beyond the reach of the minds of these people. But everything is returning "to its circles", and we are already clearly seeing and feeling this. The most important transformations in almost everything **will begin in 2023**. I will explain why on **January 19, 2020, at 01:15**, there "started automatically", on the same day and for the whole year new Programs, and **all of them – 1500**. Some programs will work **until December 22, 2020**, but most of them will be long-term programs oriented towards the "condition of the state" – when **the state changes as such, and by this changes the attitude towards the people who created this state**.

2020 is a special year! There will be a big leap in all areas of human life! In 2019 alone, the ECS "turned around" 1200 years back in line with the recreated conditions for the complex being of the Earth itself, the restoration of the true processes of the nature and Man existence, at the level of the Earth dimensionality, the reconstruction of the true control processes to ensure guaranteed conditions for the life support and much more. According to this estimation, the Earth has already returned to the level of "undistortions" to 1200 years back. It is incorrect to say in this connection about being "rejuvenated" for 1200 years. IT threw off the "distortions" of the complex state of the energy sphere. The Earth is still only recreating its two true

Altai-1 and Altai-2 Control Complexes, as a cosmophysical process for **RECREATING THE TRUE CONDITIONS** of the Earth's civilized development. In February 2013, the Chelyabinsk meteorite "flew in", and this "gave the start and demonstrated" *the Ural complex*, which was turned off 18,000 years ago, which I mentioned in my book, This is quite enough to ensure the current level of energy-information support of the true control processes including the executing actions of people and their public Consciousness formation, changes in their being processes for this transition period and so on.

You already know that with the beginning of 2020 obvious speculative effects began – for example, the "outburst" of the so-called coronavirus infection COVID-2019. There is no vaccine, how it spreads – **NOBODY** can say **ANYTHING** definite – they only speculate and, most importantly, it is hushed up that people "infected", in addition to pneumonia, have intestinal perforation and death occurs in 3-8 days. In China, a huge number of people died from intestinal perforation. People of the "yellow race" are dying all over the world, but the virus has already stepped onto the African continent. However, the conclusion that the "yellow race" is susceptible to infection is **WRONG**. As soon as the Brain of 4XX Genotype becomes an "orphan" (without energy-information support), the viruses begin to "eat" the lungs and then take up the intestines. For all that, the virus is formed from its own cells, and the Brain takes the virus for its structures. One thing I can say for sure – the people who live in Russia now, with the exception of some (though, in my opinion, they are more than enough) of the most active individuals, are not threatened.

Against the background of the ongoing, I'll tell you about the principle of "work" of the created **"PORTAL OF KNOWLEDGE"** (its personal accounts) within the framework of usefulness with and without the "SvetL" Complexes. I will open the "secret" – why, under certain actions of a person within the framework of the User's Instructions, an individual is scanned **to GET CONTACT WITH HIS BRAIN**. Why and how the cause of certain Brain deviations related to the reaction (no reaction, passivity) to all changes occurring at the moment both in the short and long term becomes visible – the mechanisms of interaction are "turned **on**" and with the help of field physics the **BRAIN GEOPHYSICS WILL BE CHANGING**.

You will know that the fires beyond the Urals and around Lake Baikal, destroying vast territories and causing fear and horror both to the "rulers" and to their structures (Ministry of Emergencies, Armed Forces and local

authorities), **IS NOT ANYTHING ELSE**, but a "planned" cleaning of territories from the "unnecessary". It burns where there should not be any forest in the future of the tasks to be solved.

You will know that for those who live now far from their birthplace, once every 8-15 years (cycle) it is necessary to visit their homeland at least **FOR SEVERAL DAYS. 8 and 15 years** is the correction related to the biological cycle, and you should understand that the homeland is the best generator of both healing and knowledge. The main thing is to want to know, because if you want to, you will know, but when you know, you will not know everything. One way or another, all the questions that arise in you are indicators, first of all, of the fact that the movement goes on. This alone cannot but make you happy, **but it is time not to ask questions, but look for the answers to them.** Then the movement is more likely to **TAKE THE RIGHT DIRECTION.**

And, as advice, especially to young people, in this process of "getting knowledge" – never shout "**Eureka!**" This word is from Hebrew. You never should say, "**Wow!**" Do not listen to young people, because "**Wow!**" – is in the Russian translation of "**fuck all!**" American Wow! And since we pretend to be intelligent and do not swear (although sometimes you really want to, and especially in the process of getting knowledge), you can say: "**Yeah!**"

A man now, being in a whirlpool of events, destinies, lies and falsehood, was able to gather all his courage, will and reason (in the existing format), seeing in the ongoing everywhere around, not just all round lawlessness, but the manifest of the all-round inexpediency of the artificial construction of being on the worldly plane, which is provided and supported by something that is obscurely grasped from the outside, is in the state when in his own personal world everything suddenly collapses and turns into dust. **EVERYTHING AND AT ONCE!** Everything turns out to be a correctly faked slip, and worked out, as you now see and, roughly and primitively enough to make you gasp for breath or use extremely clear lexical constructions that do not require translation (at least to a Russian Man), thus expressing all your annoyance, powerlessness before the accomplished, and at the same time unbearably burning desire, now when the absurdity of everything you were sure of is clear to you, – to see and comprehend the truth. And here you clearly understand that this tiny little step, for all its importance to itself, is the **SIMPLEST OBVIOUSNESS**, previously imperceptible because of your own stupidity, but with its brilliant simplicity,

causing an uncontrollable impulse, the only one that can be expressed **through the Russian "fuck off..!"** – and you understand that **for someone it perhaps even worse...** Someone is not able even to express this, if it suddenly happens, limited by the only, fashionable and ugly chopped off **"Wow!"**

As a result, there comes a moment when they say: **"all this is good, of course, – but what to do...?"** And as it turns out, no one knows the answer, but for some reason everyone thinks that there is an answer. And it is necessary for us to see that there is an answer, but **EVERYONE HAS HIS OWN** answer, so it's known where to look for it but in what way? – This is up to everyone, and you can probably do this from the swamp. Well, the indicator that the "process is in progress" – for many of you is the same "wow" in translation or without it, depending on the degree of "fucking" with the next kick (jab) made by those who had time for it. Here and in my other books, and in this, which you are now finishing to read, there are many places for all of you where while reading you suddenly are rooted to the spot, and then say this "wow!", Or, what I am more confident, the translation will be voiced immediately. This is where I end this book of mine.



Now you can lower the periscope and give the command – **"Boatswain! Descend into the Depth..."** as I used to do when **I was the commander of nuclear submarine K-369!**

I express my sincere gratitude to all those who helped me in writing this book, and especially to the talented Belarusian artist Irina Barsukova (Vitebsk) by the selection of her drawings.

Содержание

.....	3
Chapter 1. Comment to yet not told	24
Chapter 2. Claim for a title	81
Chapter 3. To make a lot of steps for the sake of the next one. ...	140
Chapter 4. The seamy side of simplicity	200
Chapter 5. To be in time – not to be late	267
Chapter 6. To see the sound and to hear the colour	327
Chapter 7. To hear and to listen to	381
Chapter 8. Hearing and listening	485
Afterword	547