



TM

Venieri
SPA

4.63H

5.63C

WHEEL LOADERS





4K LINKAGE.

New completely redesigned linkage to the latest state of the art, for **maximum break-out force and interchangeability with previous versions.**



AUTO SAFETY IS OUR PRIORITY.

The negative parking brake is integrated into the front axle for maximum safety in all operative conditions *(optional on 4.63H).*



SILENCE, PLEASE.

Thanks to the new sound proof technology and special "anti vibration" rubber shock absorbers it was possible to reach **a deeply noise reduction inside cabin, for maximum comfort** for the operator.



360° BREATHTAKING VIEW.

The new cabin design guarantees **360° visibility**, for **complete working control** on each attachment installed granted the **best safety condition ever. Cabin level II ROPS/FOPS.**



BE COOL.

The **brand new ventilation system** grants an high level of operator comfort. With **VENIERI CLIMATRONIC** or thanks to new technological Air-condition you can find the perfect Environment inside your cabin.



100% VENIERI DESIGN.

In the new machines our **Venieri Design Lab** follows the "family feelings" but introduces significant **stylistic innovations.**

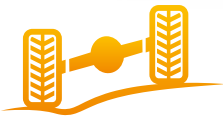

TOTAL STABILITY.

Oscillating rear axle fixed to the frame with **maintenance-free** supports.



TIER IVf ENGINE.

The new **Yanmar** and **Deutz** engines comply with the **latest emission standards** delivering **high torque** at low rpm.



AIR CYCLONE PRECLEANER

ALWAYS CLEAN AIR.

The new air cleaner system offers a **two stage filtration**, through **high efficiency primary filters** and **safety filters**, that could integrate with cyclon pre-filter (*optional on 4.63H*) for maximum engine protection.



DOUBLE ATTENTION FOR FUEL SAVING.

The new electrically controlled **dual speed cooling fan**, adjusts the rotation speed according to the working conditions, **reducing fuel consumption and noise**.



BUILT FOR POWER, DESIGNED FOR AGILITY.

The **special layout of the counterweight** grants **perfect maneuverability**, **maximum drive angle** and protection of the integrated rear lights in narrow spaces.

5.63C

WHEEL LOADER - "Z" LINKAGE



DIESEL ENGINE

4 cylinder in line, turbocharged, common-rail injection with electronic control, exhaust gas recirculation, water cooled, dry filtration, oxidation catalyst (DOC). Emissioned according to CE 97/68 - TIER IVf.

Type	Deutz TD 2.9 L4	
Max. power	58 kW - 79 HP	
Rated rpm	2.600	
Power ISO/TR 14396	55,4 kW - 75 HP	
Power EEC 80/1269	55,4 kW - 75 HP	
Economic working range	rpm 1400 - 1800	
Max. torque	ft lbf	260
Bore	mm	92
Stroke	mm	110
Displacement	in ³	178



ELECTRIC SYSTEM

Battery	12 Volt	
Capacity	110 Ah - 850 A	
Alternator rating	95 A	
Reverse warning	Standard	
Wiring according to	IP 67 - DIN 40050	



TRANSMISSION

Hydrostatic transmission with automatic power regulation and closed circuit with pumps and variable displacement engine. Gearbox with 2 mechanical selections: 2 work speeds (fwd/rev) and 2 road speeds (fwd/rev).

Work speed	Forward	Reverse
1 st gear mph	0 ÷ 2	0 ÷ 2
2 nd gear mph	0 ÷ 7	0 ÷ 7

Road speed	Forward	Reverse
1 st gear mph	0 ÷ 9	0 ÷ 9
2 nd gear mph	0 ÷ 25*	0 ÷ 25*

* Self limited max. speed



AXLES

Two heavy duty equal size axles with planetary final drives in each wheel. Fixed rigid drive axle. Oscillation rear axle on rear chassis section up to a total angle of 25°. Transfer gearbox transferring movement directly to the rear and to the front axle via transmission shaft. Self locking limited slip differential on front axle. Self locking limited slip differential on rear axle (optional).



BRAKE

Service: hydraulic multi-disc oil brake on front and rear axles. Parking brake: negative hydraulic on front axle, electrically applied.



TYRES

Standard	405/70 R20
Optional	455/70 R20 • 14.5 x 20



STEERING

Servo-assisted steering **LOAD SENSING** system.

Total steering angle	80°	
Inner tyres turning radius	ft in	8'5.77"
External tyres turning radius	ft in	14'9.76"
External bucket turning radius*	ft in	16'4.06"

* Bucket on traveling position



HYDRAULIC SYSTEM

Two gear pump, the first for loader and steering circuit with LOAD SENSING valve, the second for the fan circuit with two rotating speed. Modular two-element control valve with main relief valve. Double acting hydraulic cylinders.

Hydraulic oil cooling radiator. Full flow oil filter on return line. Single servo lever arm control with 4 position lifting system and with 3 position bucket system.

Max. flow	gpm	23.78
Max. flow with high flow (optional)	gpm	30.38
Loader relief valve pressure	psi	3,336
Steering relief valve pressure	psi	2,756
Lift cylinder	in	3.35x22.83
Bucket cylinder	in	3.54x15.83
Lifting time (full)	sec.	4.38
Lowering Time (empty)	sec.	3.41
Unloading Time	sec.	1.9
Total cycle time	sec.	9.69



SERVICES CAPACITIES

Engine	gal	2.11
Front axle	gal	1.37
Rear axle	gal	1.64
Gear box	gal	0.48
Hydraulic circuit	gal	18.49
Brake circuit	gal	0.53
Fuel	gal	19.81
Water cooling	gal	3.96



TECHNICAL FEATURES

Standard bucket capacity	yd ³	1.44
Bucket width	ft in	6'10.68"
Straight static tipping load	lbs	10,913
Full turned tipping load	lbs	9,700
Lifting capacity at max. height	lbs	9,149
Hinge pin height	ft in	11'0.28"
Dump height at 40°	ft in	2'1.98"
Reach at 40°	ft in	660
Breakout force	lbs	14,110



DIMENSIONS AND WEIGHT

Max. length in transfer position	ft in	17'4.46"
Max. width in transfer position	ft in	6'10.68"
Tyre external width	ft in	6'4.26"
Track width	ft in	5'0.24"
Wheel base	ft in	7'5.57"
Ground clearance	in	12.99
Max. height	ft in	9'0.66"
Standard operating weight	lbs	12,787
Max. permissible weight	lbs	13,823

dB NOISE LEVEL

Noise level inside cabin ISO 6396 - LpA	dB(A)	75
Exterior noise level ISO 6395 - LwA	dB(A)	99

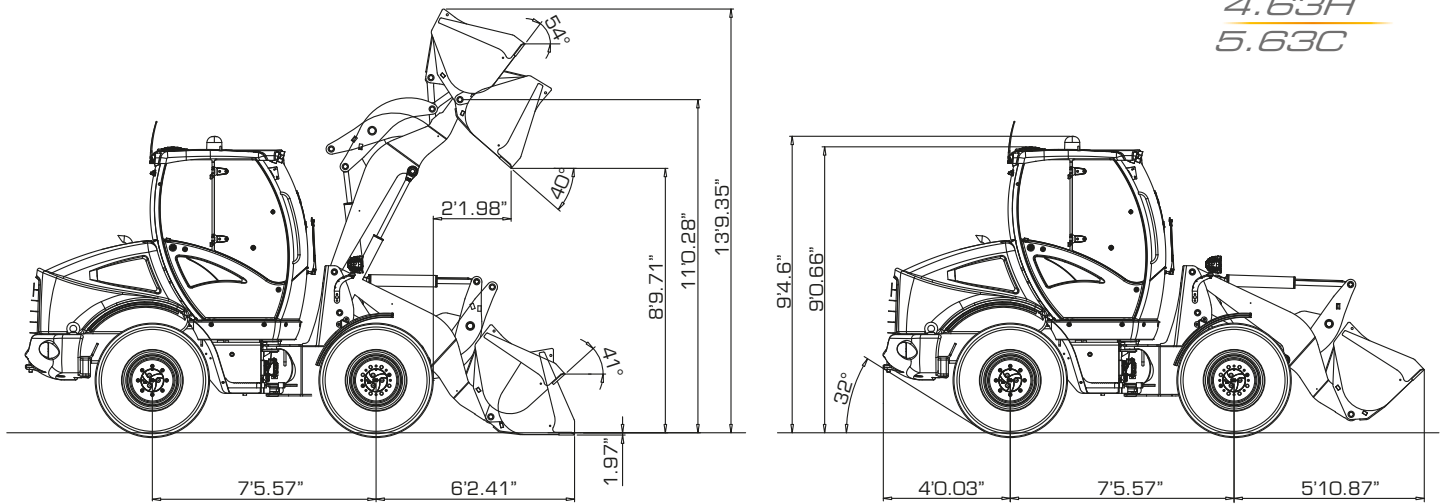

PERFORMANCE DATA



UNIVERSAL BUCKET



MULTI PURPOSE BUCKET



OVERSIZE

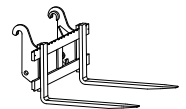

FORKS

		UNIVERSAL BUCKET	MULTI PURPOSE BUCKET	OVERSIZE	FORKS
Full load bucket capacity (SAE)	yd ³	1,44	1,18	1,96	/
Bucket width	ft in	6'10.68"	6'10.68"	7'4.58"	/
Bucket weight	lbs	882	1,102	1,102	/
Overall operating height, fully raised	ft in	13'9.35"	13'7.19"	13'11.32"	/
Forks lengthh (Standard)	ft in				3'3.37"
Forks lengthh (Optional)	ft in				3'11.24"
Hinge pin height	ft in	11'0.28"	11'0.28"	11'0.28"	/
Dump clearance	°	40°	40°	40°	/
Dump height	ft in	8'9.71"	8'8.69"	8'7.7"	/
Dump distance	ft in	2'1.98"	2'1"	2'3.95"	/
Max dump distance	ft in	3'2.58"	3'0.61"	3'4.55"	/
Bucket static tipping load, straight	lbs	10,913	11,354	10,362	/
Bucket static tipping load, full turn	lbs	9,700	10,141	9,149	/
Forks static tipping load, full turn	lbs				7,496
Payload EN 474-3 (80%) [●]	lbs				5,997
Payload EN 474-3 (60%) [●]	lbs				4,497
Breakout force	lbs	14,110	15,190	13,250	/
Total length	ft in	174.46"	179.58"	181.52"	/
External bucket turning radius	ft in	16'4.06"	16'2.49"	16'8.39"	/
Standard operating weight	lbs	12,787	13,007	12,787	/

[●] Center of gravity 19.69"

POWER

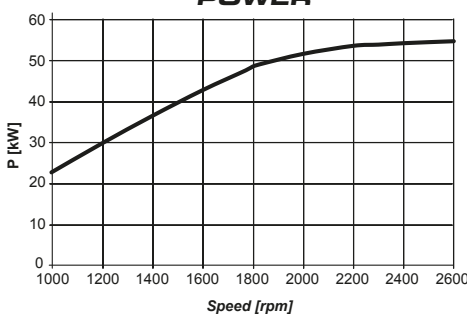

TORQUE

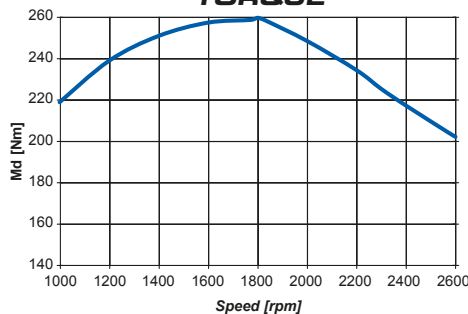

FUEL CONSUMPTION

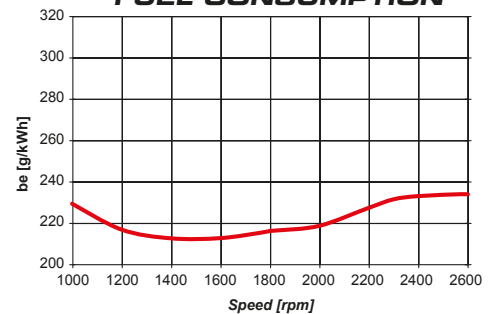

THE NEW CABIN

A BREATHTAKING VIEW.

Take a seat in your customized control room. Create your ideal work space by **adjusting** the **pneumatic seat*** and the **steering wheel** to suit your specific needs. Select the commands, **all at your fingertips**. Excellent **visibility to 360°** gives you the best view to work with maximum efficiency. The combination of **breathtaking cabin** and the **latest state of the art of 4K linkage** allows the **maximum control** of your attachments.

**Optional.*



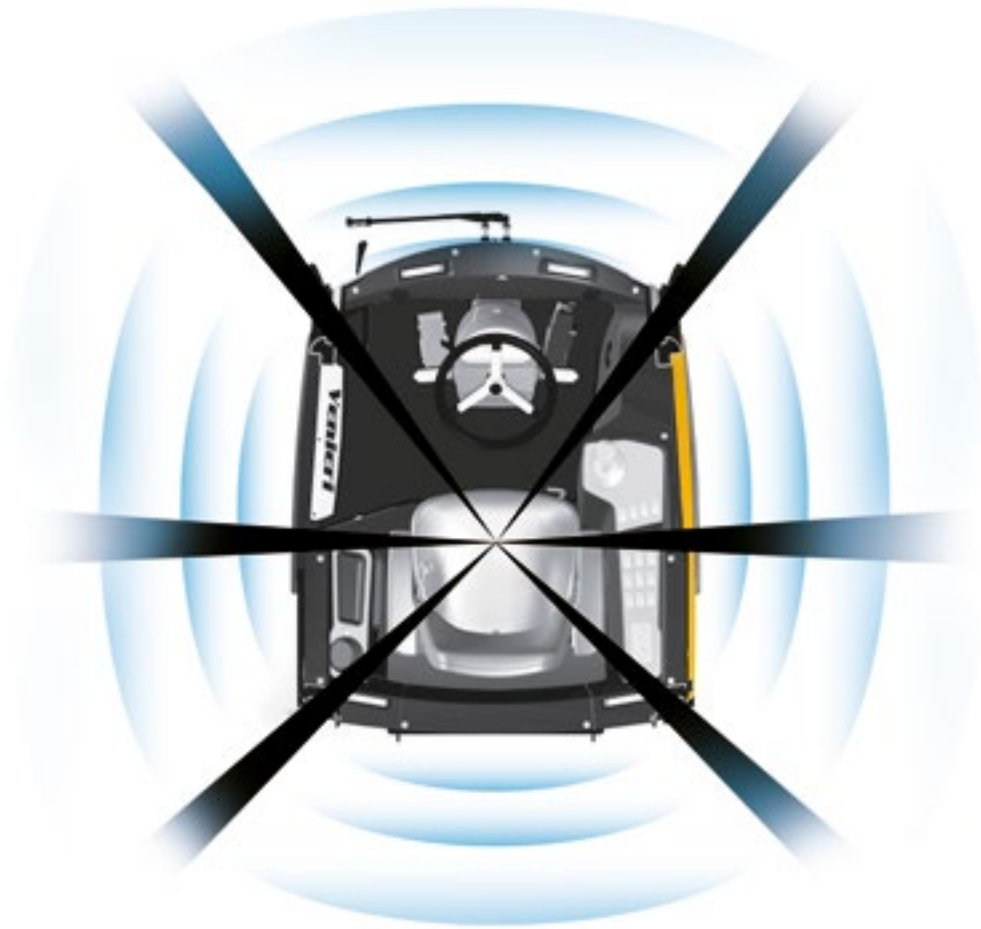

In the new 5.63C and 4.63H cabin we **minimized "blind spots"** for **superb visibility** in all working conditions.

OPEN SESAME!

The **door with double opening** allows the operator to work with the entrance door closed, with top glass opened, ensuring **maximum ventilation** even with the A/C off and **without protruding parts out of shape**.



5.63C

BEAUTY FINALLY MEETS FUNCTIONALITY.

The Venieri Design Lab, with the 5.63C new cab tried to merge **function** and **style** with the aim of become the best in the market. The new interior design has also allowed us to create different compartments useful for storing small tools, mobile phone, beverage, and more.



ARTIFICIAL INTELLIGENCE.

Advanced man/machine interface, which constantly **monitors the performance of the machine** and communicates **each diagnosis** to the operator via a large and detailed LCD screen in the dashboard.

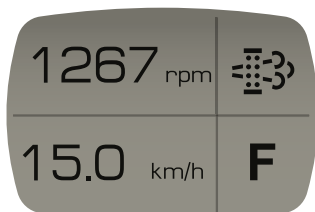

LAYOUT A

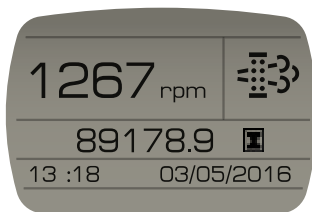

LAYOUT B

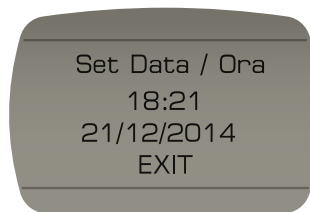

SETTINGS

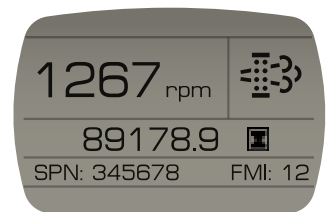

ENGINE ERROR

CLASS EVOLUTION.

CLEAN POWER, ZERO CONSUMPTION. NEW DEUTZ STAGE IIIB/TIER IVf ENGINES

The engine that equips the 5.63C is the **new Deutz TD 2.9 L4**, a four cylinder unit of **178 in³** awarded as **best engine in his class**. The impressive performance, reliability and durability distinguishing this engine have been made possible by adopting the most advanced technology, such as: **external exhaust gas recirculation, electronically controlled Common Rail injection with 23,206 psi of pressure, turbocharger and wastegate valve**, and much more for a minimum specific consumption of **just 0.5 lbs /kWh**, - an outstanding figure for an engine of this size - which, through the use of an external gas recirculation system and the diesel oxidation catalyst (**DOC**) compliance with the **Tier 4f** emissions regulations and achieved.



5.63C

Deutz TD 2.9 L4
58 kW - 79 HP

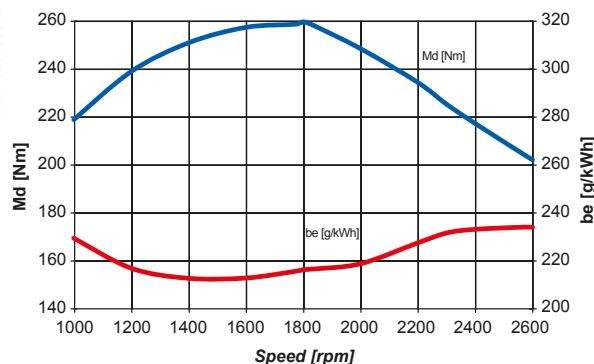
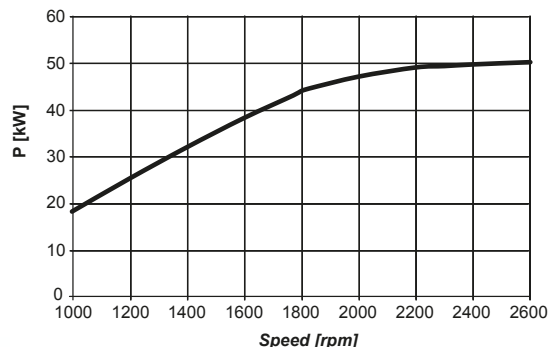

JAPANESE TECHNOLOGY YANMAR ENGINE STAGE V/TIER IVf

The engine that equips the 4.63H is the **new Yanmar 4TNV98C**, a four cylinder unit of **203 in³** with **EGR system (Exhaust Gas Recirculation)** and **Diesel Particulate Filter DPF**; this has the peculiarity to operate without additives by capturing the fine dust of the exhaust gases and burning them during the automatic regeneration process, **keeping the filter clean** and keeping operating costs down. The DPF can work in three different modes: **assist regeneration, active regeneration, stationary regeneration**.

The Yanmar engine is equipped with a **Common Rail electronic injection system**, that grant an accurate control of the injection and combined with the exhaust treatment system, ensures **low fuel consumption** and reduces pollutant emissions.



4.63H

Yanmar 4TNV98C
53 kW - 72 HP

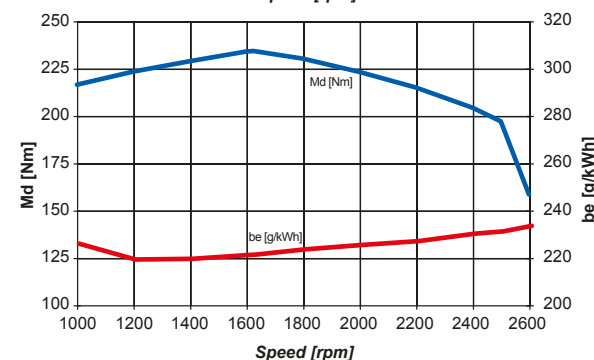
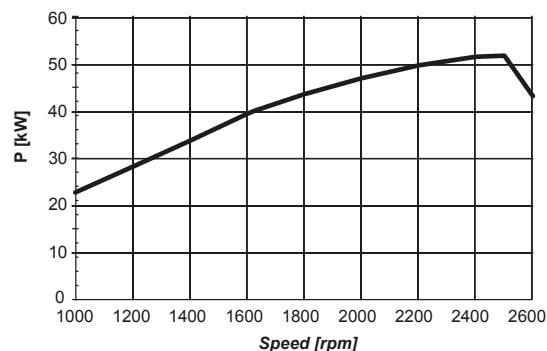

Venieri GLOBAL

CONTROL YOUR FLEET

Venieri GLOBAL™ is our brand-new satellite monitoring system, which guarantees an increase in productivity by providing detailed information about the fleet and attachments, as well as an incredible amount of data to ensure the highest performance levels and greater economic efficiency.

AVAILABLE FEATURES

Machine localisation	✓	Work shifts alarm	✓
Alerts history	✓	Standard operating procedure history	0
Maintenance plan	✓	Energy-saving guidelines history	0
Maintenance history	✓	Location log	✓
Load information	✓	(map with locations and operating procedures)	✓
Working hours	✓	Information about diesel particulate filter	✓
Security control (engine block)	0	Geo-fencing	✓
Fuel consumption (total and partial)	✓	Localisation and management fleet	✓
Fuel consumption while working	✓	Multiuser control with specific access policies	✓
Machine efficiency (while working)	✓	List of "sleeping" machines	✓
Detailed working hours	✓	Sms/e-mail notification	✓
Motion sensor alarm	✓	Anti-theft alarm	✓
Curfew alarm setting	✓	Parameters setting upon request	0

✓ Standad 0 Optional X Not available

REPORTISTICA: CONSUMO CARBURANTE
DA: 11/10/2018 00:00:00 - A: 11/10/2018

PRODUCTIVITY REPORT

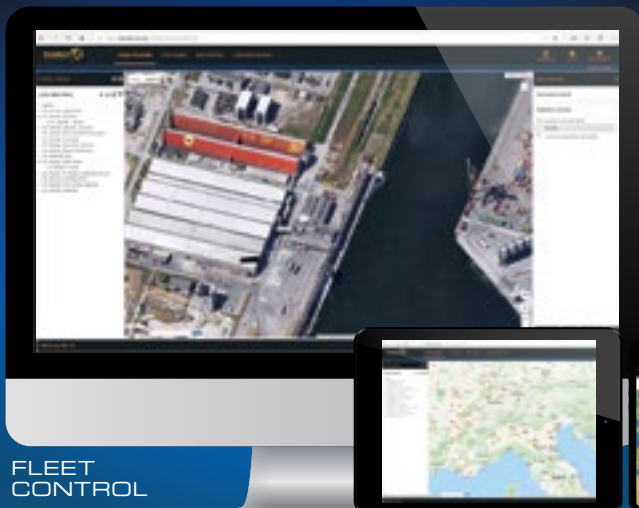
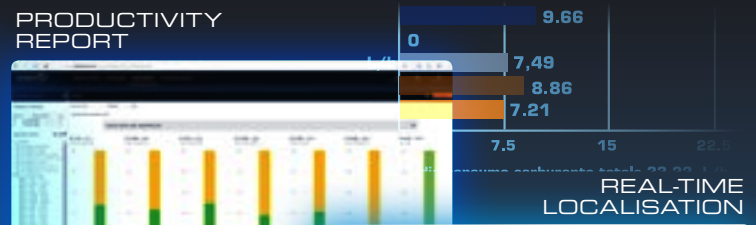

FLEET CONTROL

APP FOR SMARTPHONE
iOS™ AND ANDROID™

BASIC MACHINE



Battery main switch	•	•
Tool box	•	•
Fuel preheating (cold climates)	0	0
Plugs with keys for fuel and hydraulic tanks	•	•
Proportional self lock front differential	•	•
Proportional self lock rear differential	0	0
Differential lock 100% engageable in front axle	0	0
Trailer coupling	•	•
Warning beacon	•	•
Soundproofing	•	•
Spare parts catalogue	•	•
User manual	•	•
Type-approval for road traffic	•	•
Safety clamp for bucket and lifting cylinders	•	•
Autolevelling ground level for bucket	•	•
Speed reduction kit	0	0
"Venieri GLOBAL" system	0	0
Double-speed hydraulic fan	•	•
Reversible fan (for radiator cleaning)	0	0
Hydraulic negative parking brake	0	•
Service brake on both axles with separate circuits	0	•
Inch pedal integrated in brake pedal	0	0
Greasing points grouped on the frame	•	•
Automatic centralized greasing system	0	0
Ride control	0	0
Engine preheating system	0	0
Environmentally-friendly hydraulic oil	0	0
Hydraulic oil ISO 46 (cold climates)	0	0
Cyclone dust separator	0	•
High speed Kit	0	-

CABIN EQUIPMENT



ROPS/FOPS 2nd Level, pressurized and soundproofed	•	•
Front and rear windscreen wiper with washer	•	•
Halogen work lights (4 front + 2 rear)	•	•
LED work lights (4 front + 2 rear)	0	0
Mobile phone compartment	•	•
Bottle holder	•	•
Document compartment	•	•
Seat with mechanical suspension	•	•
Seat with pneumatic suspension	0	0
Seat with pneumatic suspension and heating	0	0
Seat armrests	•	•
Buzzer	•	•
Cabin carpet	•	•
Clothes hangers	•	•
Radio preparation	•	•
Supplementary socket 12V	•	•
Manual Air Conditioning	0	0
"Climatronic Venieri" system	0	0
Ceiling lamp	•	•
Sun visor	•	•
Rear view mirrors	•	•
Heatable rear view mirrors	0	0
First-aid kit	0	0
Fire extinguisher 4.41 lbs	0	0
Seat belt	•	•
Instrumentation and dashboard with LCD display	•	•
Safety glass breaker	•	•

SPECIAL EQUIPMENT



Hydraulic or mechanical quick coupler	0	0
Cement mixing bucket	0	0
Multipurpose bucket (4 in 1)	0	0
Lifting forks	0	0
Asphalt and cement planer	0	0
Snow blower	0	0
Snow blade and "V" type snow blade	0	0
Angle-tilt dozer blade	0	0
Hand operating hammer	0	0
Polishing brush	0	0
Trencher	0	0
High tip bucket	0	0
High flow kit	0	0
Unpressurized return pipe	0	0
Double auxiliary line	0	0
Rear hydraulic line (single effect)	0	0



VENIERI

Via Piratello, 106 - 48022 Lugo (RA) ITALY
Tel. +39 0545 904411 - Fax +39 0545 30389
e-mail: info@vf-venieri.com
www.vf-venieri.com

The illustrations on the present folder do not necessarily show the product standard version. Data and dimensions described in this folder are not binding. Venieri reserves the right of carrying out possible changes at any time and without previous notice because of its policy of steady development and improvement of the products.