

SKYWAY PITCHED

ROOFGLAZE

Lighting
by nature™

Technical data

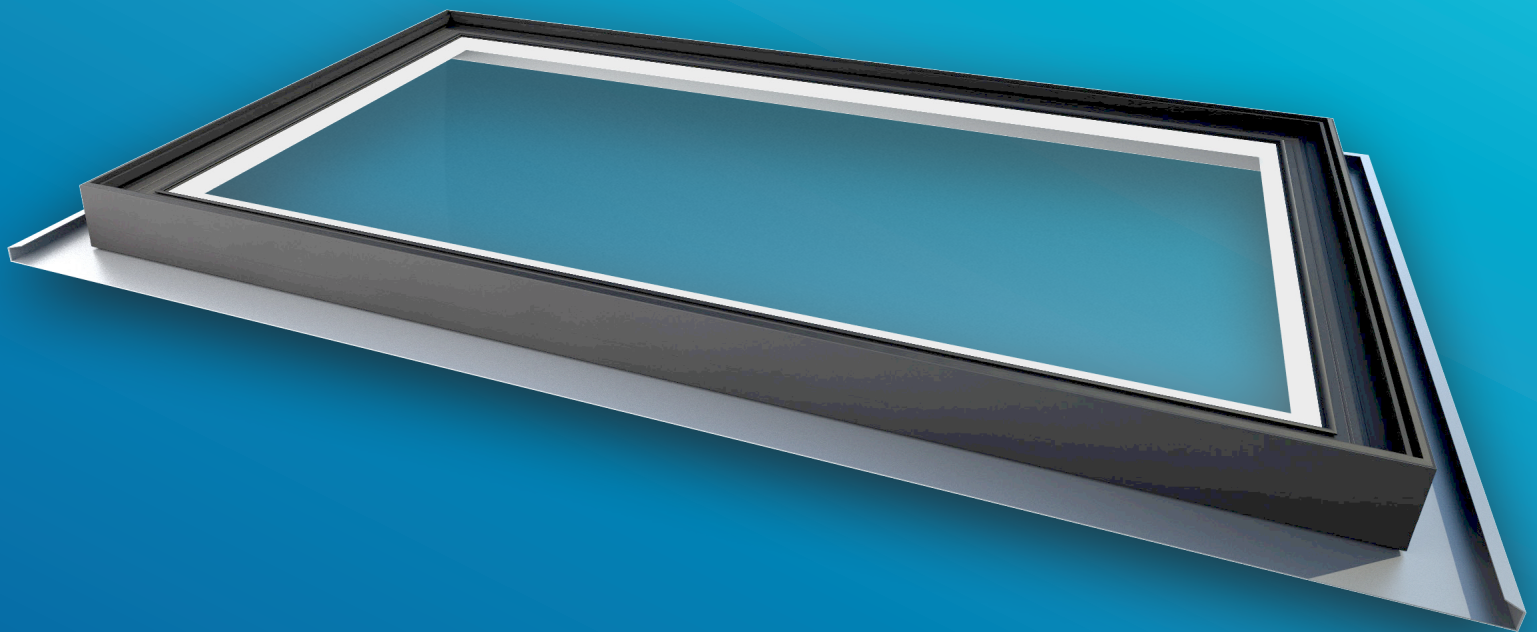

Key features

- Energy savings from maximum daylight, less artificial light required
- Quick and easy to install
- Gutter tray system to facilitate supreme waterproofing
- Designed to be installed on all roof pitches and roof types
- Stock and bespoke sizes available
- Bespoke RAL colour options also available
- Marine grade powder coating finish as standard
- Internal concealed fixings
- Stock and bespoke sizes available
- 15-Year warranty
- Unique design, minimal framework
- Low profile sight lines
- Excellent thermal performance
- U Values as low as 0.4 W/m².K
- Established British rooflight manufacturers
- Reduced risk of condensation
- Fully thermally broken aluminium frame, prevent cold bridging
- Full specification service available

A natural lighting solution for every space

Call us: 01480 474797 Email us: info@roofglaze.co.uk Visit us: roofglaze.co.uk

Skyway Pitched technical data

Framing specification

- The Skyway Pitched rooflight frame is manufactured from extruded aluminium section to BS 1474, EN 12020-1:2001 Polyamide thermal break to BS EN ISO 16396-2:2017 making the frame fully thermally broken and extremely thermally-efficient
- Marine grade coated aluminium to BS EN 12206-1:2004
- Bespoke finishes and colour options also available
- Anthracite Grey (RAL 7016)
- Matt White (RAL 9010)
- Black (RAL 9005)

Product testing and certification

- Non-fragility: CWCT TN92, with Class 1 and Class 2 compliant solutions available
- Non-Fragility Class 1 Certified by accredited third party
- Non-Fragility Class 2 Certified by accredited third party
- AA Fire-rated: AA Designation (National Class) or Broof (T4) European Class and Euro Class A1 non-combustible
- Weather tested by accredited third party to CWCT Class A4 & Class R7
- Skyway Pitch Protect+ Rooflights Part Q compliant

Critical dimensions required for order is structural opening size

- Bespoke options available
- Minimum size 500mm x 500mm
- Contact sales for maximum and bespoke sizes
- Roof design and reinforcement by others, seek professional guidance



Rooflight performance

- Building Regulations (E&W) Approved Document L compliant design to achieve low U Values
- Thermal modelling by WinIso™

U Values	As low as 0.4 W/m ² .k
G-values	As low as 0.19
Light transmission	Up to 79.1%

Design loadings

Snow	640 N/m ²
Wind	750 N/m ²

- Standard loads below

Speak to our experts about bespoke options, call 01480 474797

A natural lighting solution for every space

Call us: 01480 474797 Email us: info@roofglaze.co.uk Visit us: roofglaze.co.uk

Skyway Pitched technical data

Glass specification

- Hermetically sealed Double Glazed IGU (CWCT Class 1 & 2 Non-fragile)
- Outer: Clear toughened glass heat soak tested as standard
- Cavity: Argon filled with warm edge Swisspacer spacer + silicone bonded for a fully UV resistant edge seal
- Inner: Laminated glass with PVB interlayer and polished edges or Laminated glass with SGP interlayer and polished edges. Heat strengthened and annealed available
- Optional painted or sandblasted perimeter borders are available upon request

Contact us for a design consultation on 01480 474797

Bespoke glass options

- Solar control
- Privacy glass
- Body tinted
- Acoustic laminate
- Coloured glass
- Easy-clean coatings (Ritec)
- Triple glazed
- Low iron glass
- Switchable privacy glass
- Heated anti-condensation glass
- Paint or sandblast borders
- Artwork manifestations
- Company logo manifestations
- CUin advanced thermal performance
- Integral blind within cavity of glass IGU – zero maintenance
- **Contact us for further options**

BALANCE THE ENERGY OF YOUR SPACE

Solar control glass blocks solar radiation from passing through the IGU.

Low emissivity reflects internal heat back into the building .

Speak to us about your requirements.

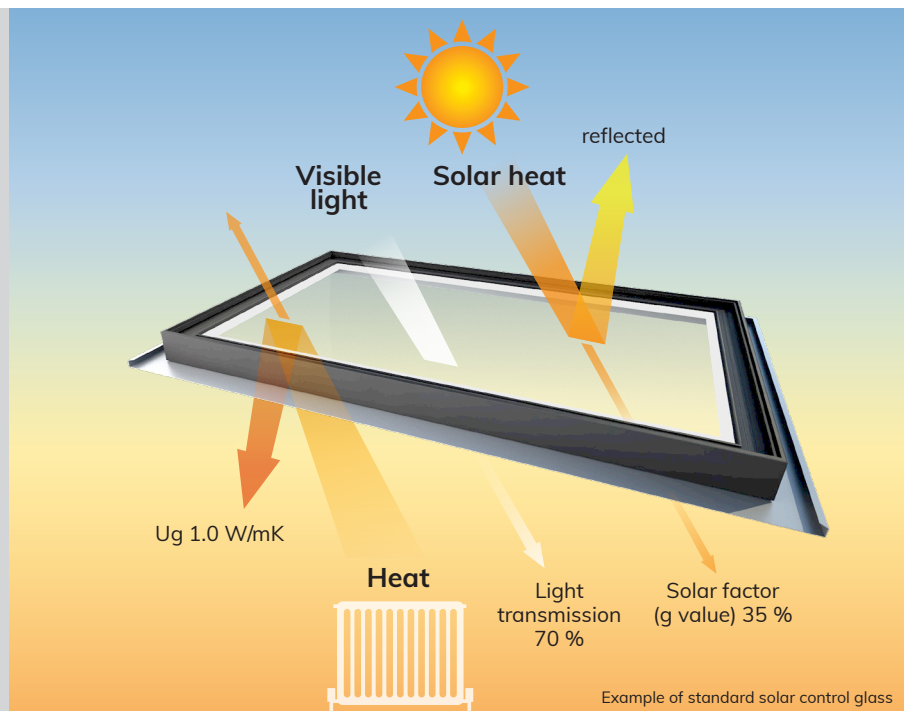

A natural lighting solution for every space

Call us: 01480 474797 Email us: info@roofglaze.co.uk Visit us: roofglaze.co.uk

Skyway Pitched technical data

Glass maintenance and aftercare

All our Skyway Flatglass rooflights can be supplied with an Easyclean Coating, the Ritec ClearShield system provides an efficient solution to greatly reduce the need for cleaning.

- Resists glass staining and contamination from tree sap, bird droppings, traffic pollution and general dirt
'Reduced cleaning time, effort, and frequency
- Keeps rooflights looking like new, staying cleaner for significantly longer
- Non-stick', easy-clean rooflight protection provides:
- Helps to maintain Window Energy Ratings
- 25 Years+ life expectancy

British Standards Compliance

BS 6375-1: 2015+A1:2016 Weathertightness

BS EN 1026:2016 Air Permeability

BS EN 1027: 2016 Watertightness

BS EN 12211: 2016 Wind Resistance

BS EN 12206-1:2004: Polyester Powder Coating

BS EN ISO 16396-2:2017 Thermal Break

BS 1474, EN 12020-1:2001 Extruded Aluminium Sections

BS EN 14351-1: 2006 + A2: 2016 Window Performance

BR443: 2019 Conventions for U Value Calculations

Available resources

- BIM objects
- NBS/ SpecifyBy specification documents
- Product CAD drawings
- Installation guides
- Install and survey services
- Thermal modelling
- Performance and structural calculations



A natural lighting solution for every space

Call us: 01480 474797 Email us: info@roofglaze.co.uk Visit us: roofglaze.co.uk

Skyway Pitched technical data

Product variations

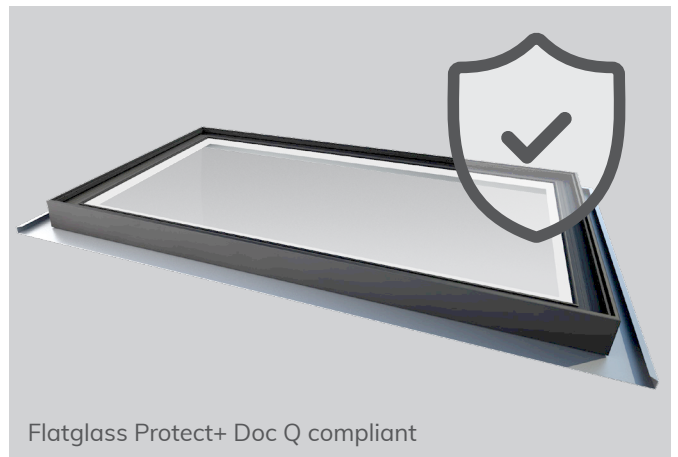
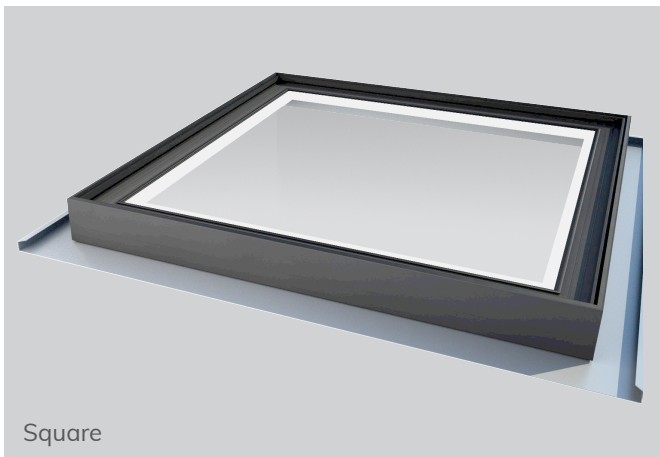
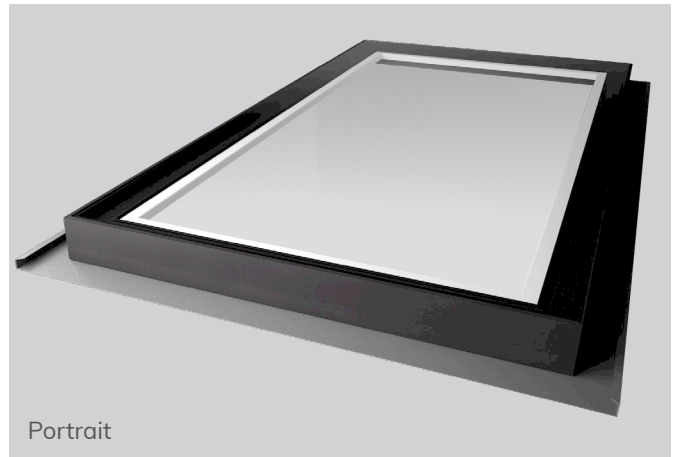
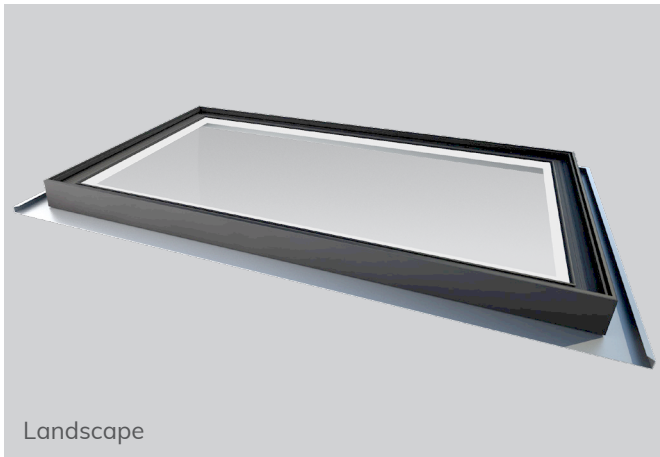

Manufactured your way

Buy with confidence from an established UK Manufacturer. The Skyway Pitched range is manufactured here in the UK, in our own factory to your personal specifications, offering glazing and shaped options to suit your project requirements.

Contemporary and unique design



Minimal frame = optimum daylight



Choice of colours and sizes



U-values as low as 0.4 W/m².k



Quick and easy to install



A natural lighting solution for every space

Call us: 01480 474797 Email us: info@roofglaze.co.uk Visit us: roofglaze.co.uk

Skyway Pitched detailing

Verge and head details

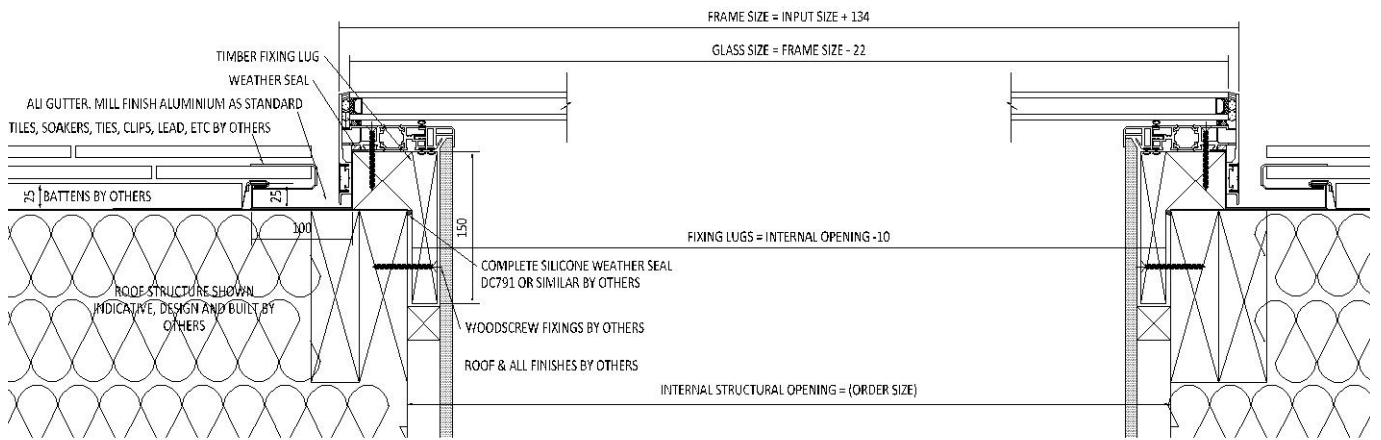

Eaves detail

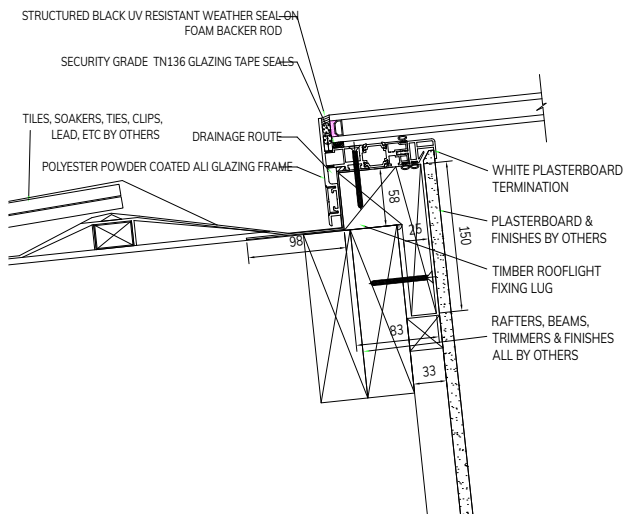

Plan view

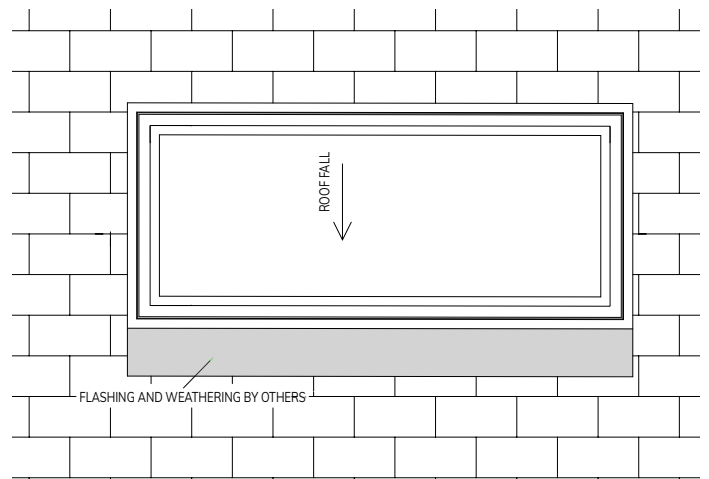

Roof underlay into gutter

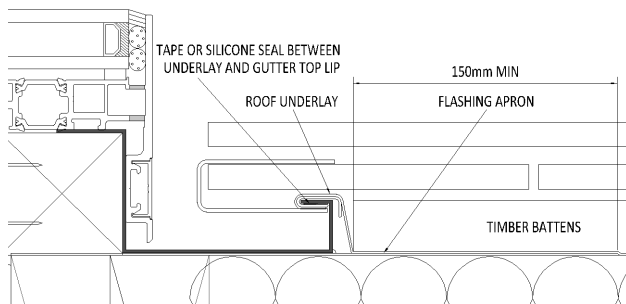

Plasterboard termination

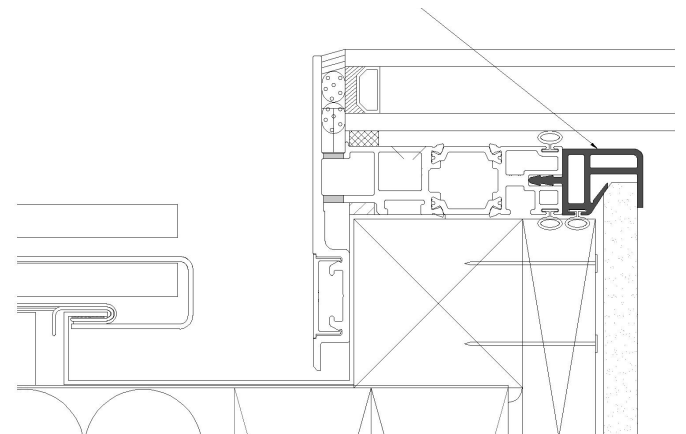

A natural lighting solution for every space

Call us: 01480 474797 Email us: info@roofglaze.co.uk Visit us: roofglaze.co.uk

A smart lighting solution for every space

Experience brighter days



A natural lighting solution for every space

Call us: 01480 474797 Email us: info@roofglaze.co.uk Visit us: roofglaze.co.uk

ROOFGLAZE

Lighting
by nature™