



CORVUS-400 Training



CLEARED
For Open Publication

Jul 15, 2025

Department of Defense
OFFICE OF PRE-PUBLICATION AND SECURITY REVIEW



The "Swiss Army Knife" Test Tool for Aircraft Maintainers and System Integrators

SLIDES ONLY
NO SCRIPT PROVIDED



CORVUS OVERVIEW

CORVUS-400 is a small, one-man carry, easy-to-use test tool for aircraft avionics and weapon systems.

A combination of hardware and software tools providing a complete MIL-STD-1553 troubleshooting/testing capability for any triax/twisted pair bus network and cable integrity testing.

CORVUS includes four testing and troubleshooting functions and associated cables.

- Bus Monitor
- VNA
- Wiremap
- D-CORVUS

CORVUS-400

NSN: 6625-01-722-8200

GSA Contract# 47QSMS25D0014



The CORVUS-400 System Includes:

CORVUS



- Size: 18" x 11.5" x 5.5"
- Weight: 18 lbs.
- Power: 60 W, 115V AC or 28V

D-CORVUS



- TX generates mimic 1553
- RX receives 1553 & analyzes result
- TX and RX can be configured "on the fly" via SW commands on CORVUS mainframe

WiFi built into RX and Mainframe
5 hours battery life between charge

VEGAS



- Size: 5.125" x 4.35" Lx 1.25"
- Weight: 1 lb.
- Power: 5 VDC 0.5 Amps

POWER PACK



- Size: 31.59" x 22.99" x 19.48"
- Weight: 42 lbs.

Min Temp -40° F (-40 ° C)
Max Temp 210° F (99 ° C)

Certifications
IP67 / Def Stan 81-41

5 Hours continuous prime power output

Includes all associated cables, connectors and adapters

TO START:

1. Connect the Grounding Cable to Ground post
2. Plug in the CORVUS - Connect the power cord to a standard 115VAC, 60Hz outlet or the Power Pack
3. Secure the power connection by hand twisting the threaded connector until it is snug.
4. Power on CORVUS by Pushing the illuminated silver Power button on the top panel.

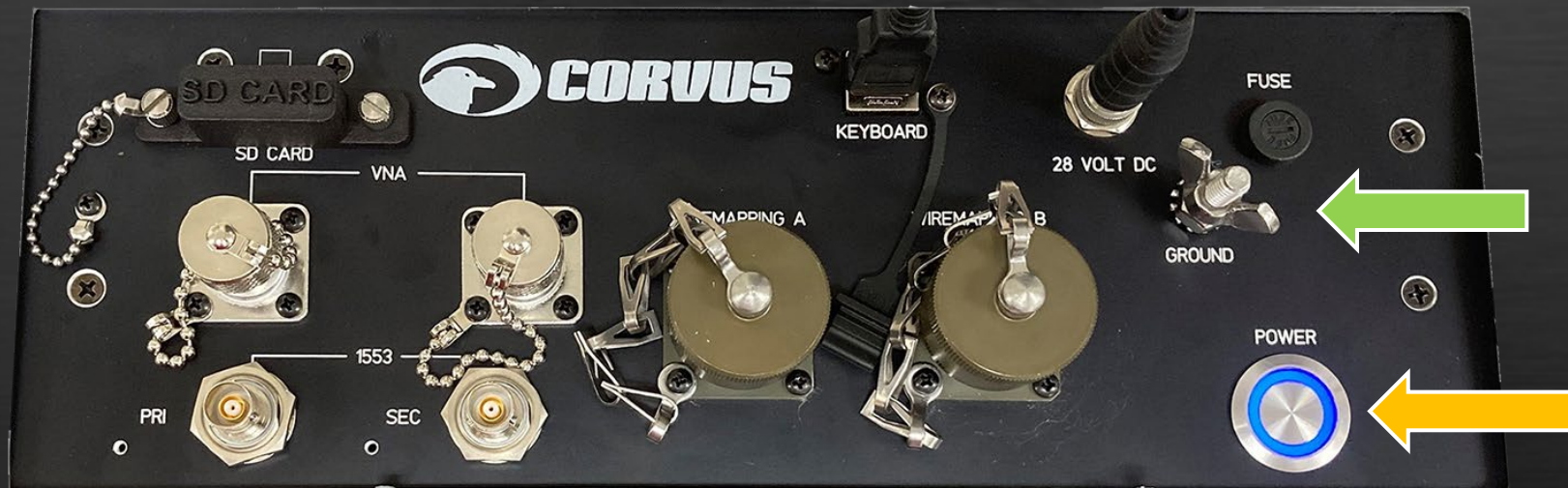

Vegas Diode

The Vegas Diode is used with the Bus Monitor to ensure that CORVUS does not transmit onto the bus. Connect the Vegas Diode to the 5 VDC output on CORVUS top connector panel. Connect the aircraft bus under test to both of the IN ports on Vegas. CORVUS is then connected to the OUT ports.

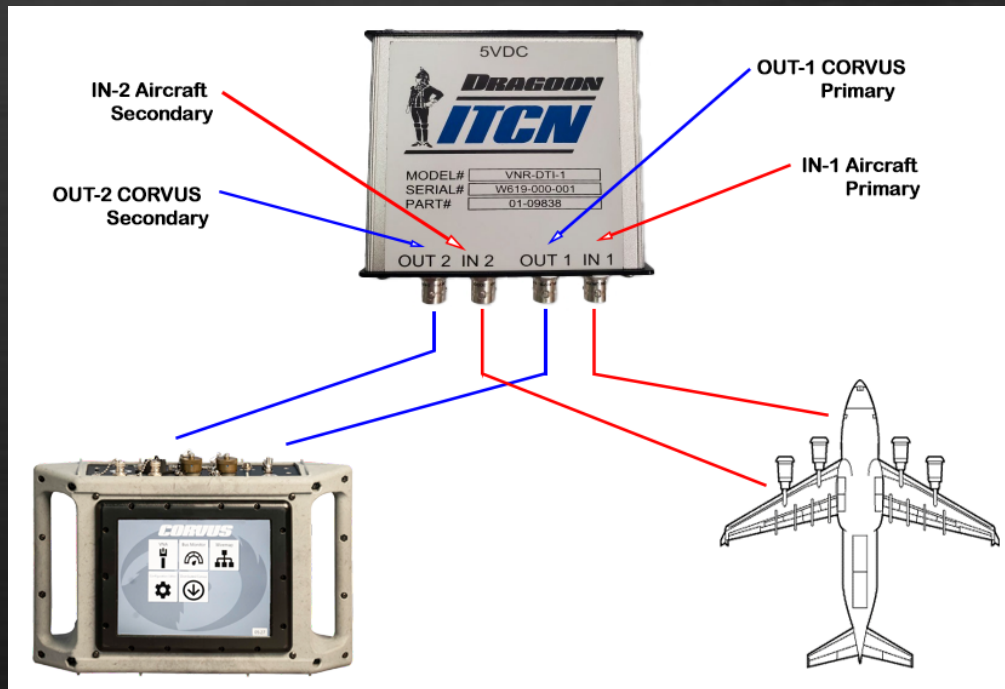

Bus Monitor

Select Bus Monitor from the Splash Screen

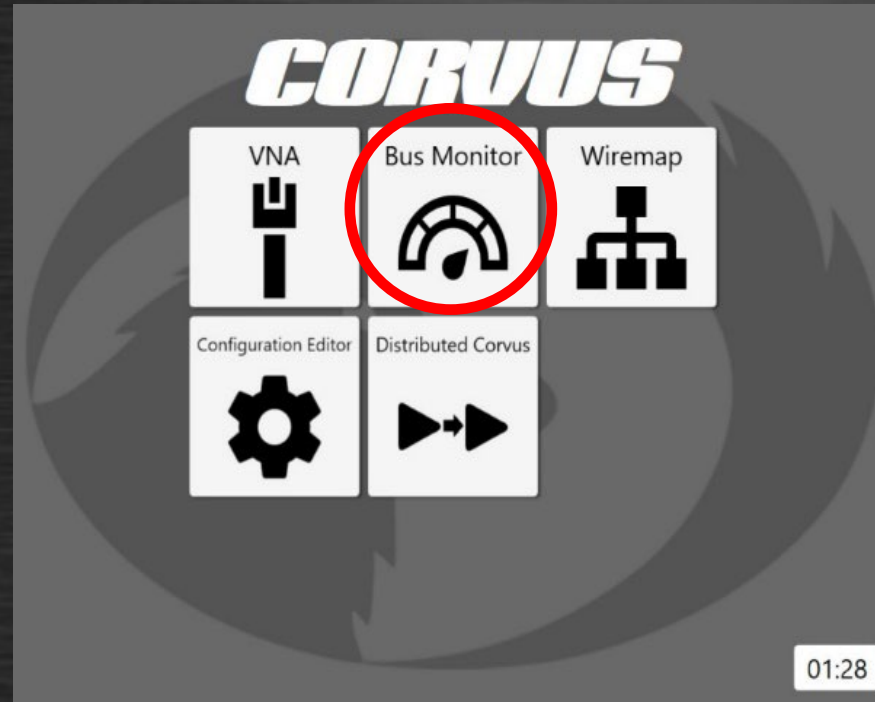

Bus Monitor ports are labeled 1553 "PRI" and "SEC" and are Trumpeter TRB connectors

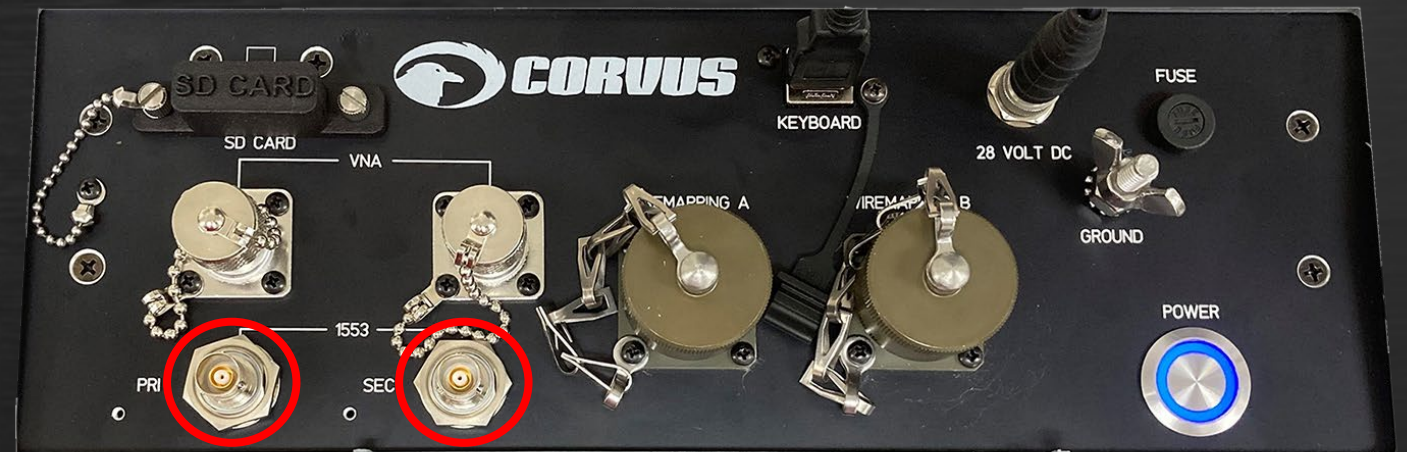

Bus Monitor 2

You can Create, View, and Edit your busses here

1. Click Yellow File icon and select your Database
2. Select Edit to build your Bus

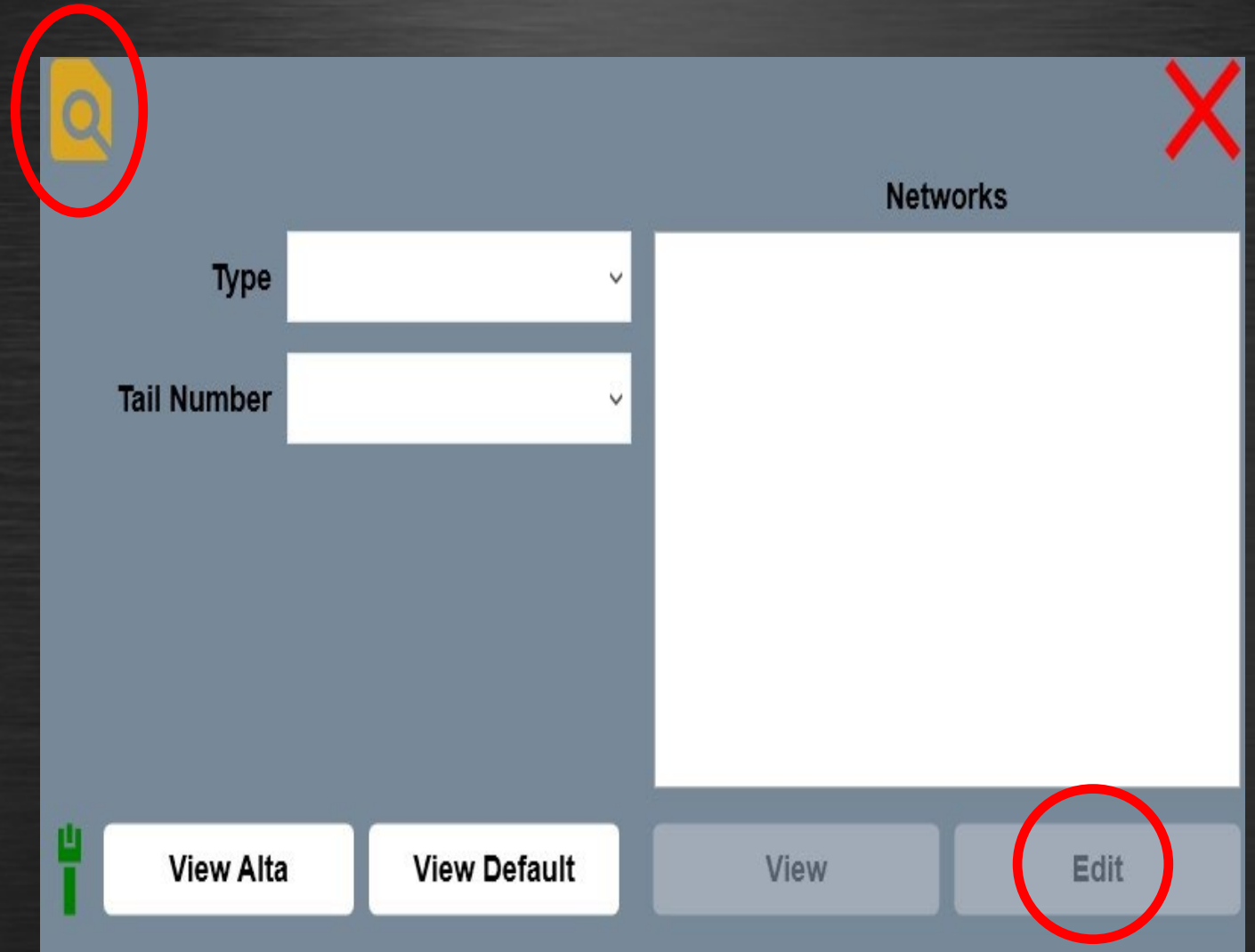

Bus Monitor 3

You will get a blank screen that looks like this

Add **couplers** and **RT's** by clicking the **blue** and **cyan** buttons

Connect RT's and couplers by clicking the stub connector icons on them

Connect couplers to each other by clicking the bus connector icons. Right clicking a bus connector will let you add/remove a terminator

You can set R/T names and addresses once they are added

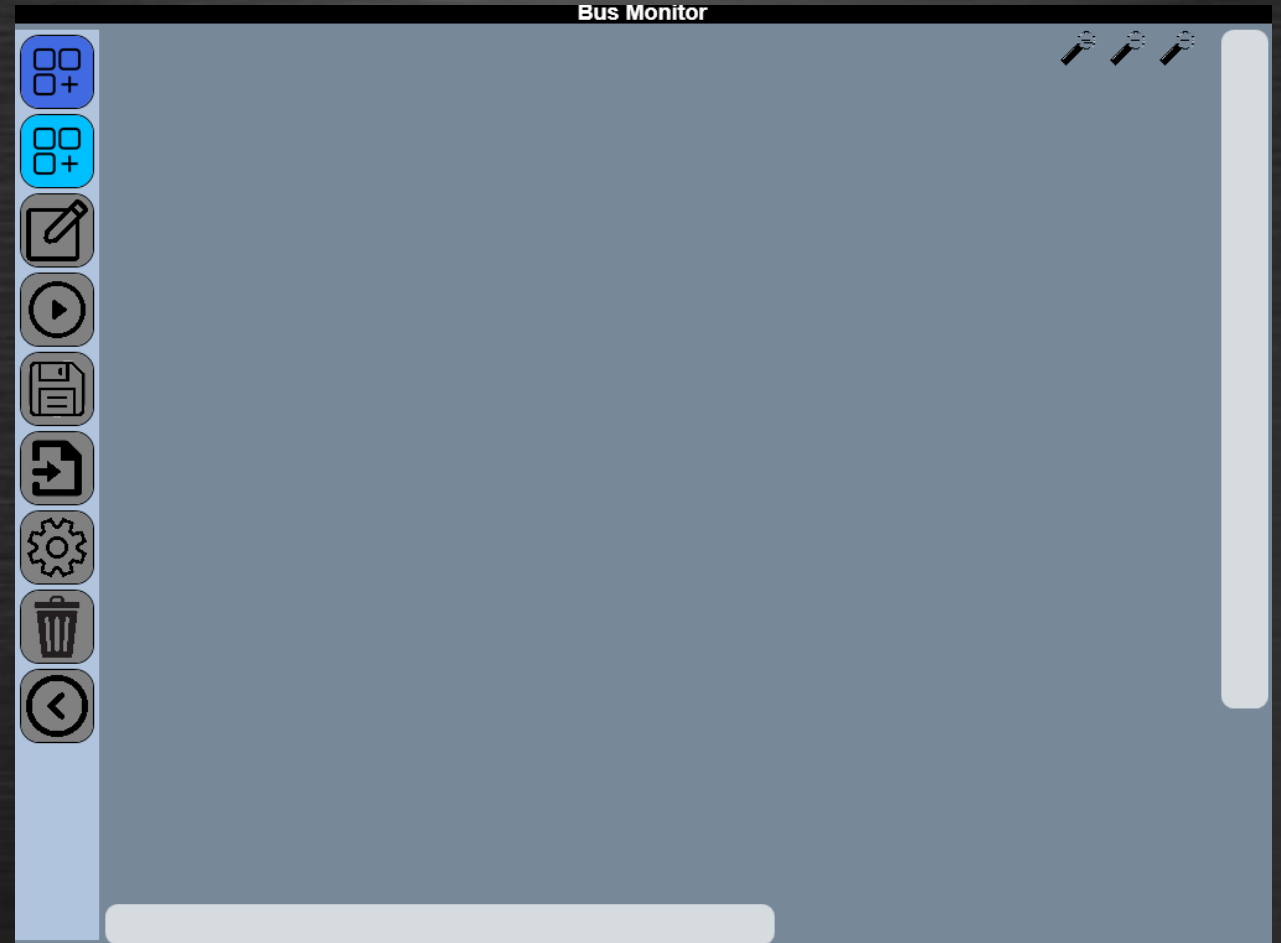

Bus Monitor 4

This is what your completed Bus will look like with a mix of good and bad data



Good Data is shown with a **Green** highlighted box

Bad Data is shown with a **Red** highlighted box

No Data is shown with a **Yellow** highlighted box

The error/message count is shown on the terminal for both primary (top) and secondary (bottom) buses

You can view errors by clicking the **red** highlight on the R/T and select filters by clicking the filter button next to it.

Bus Monitor Error/Filter

Here you can view each error that occurred and the breakdown of each command that caused the error

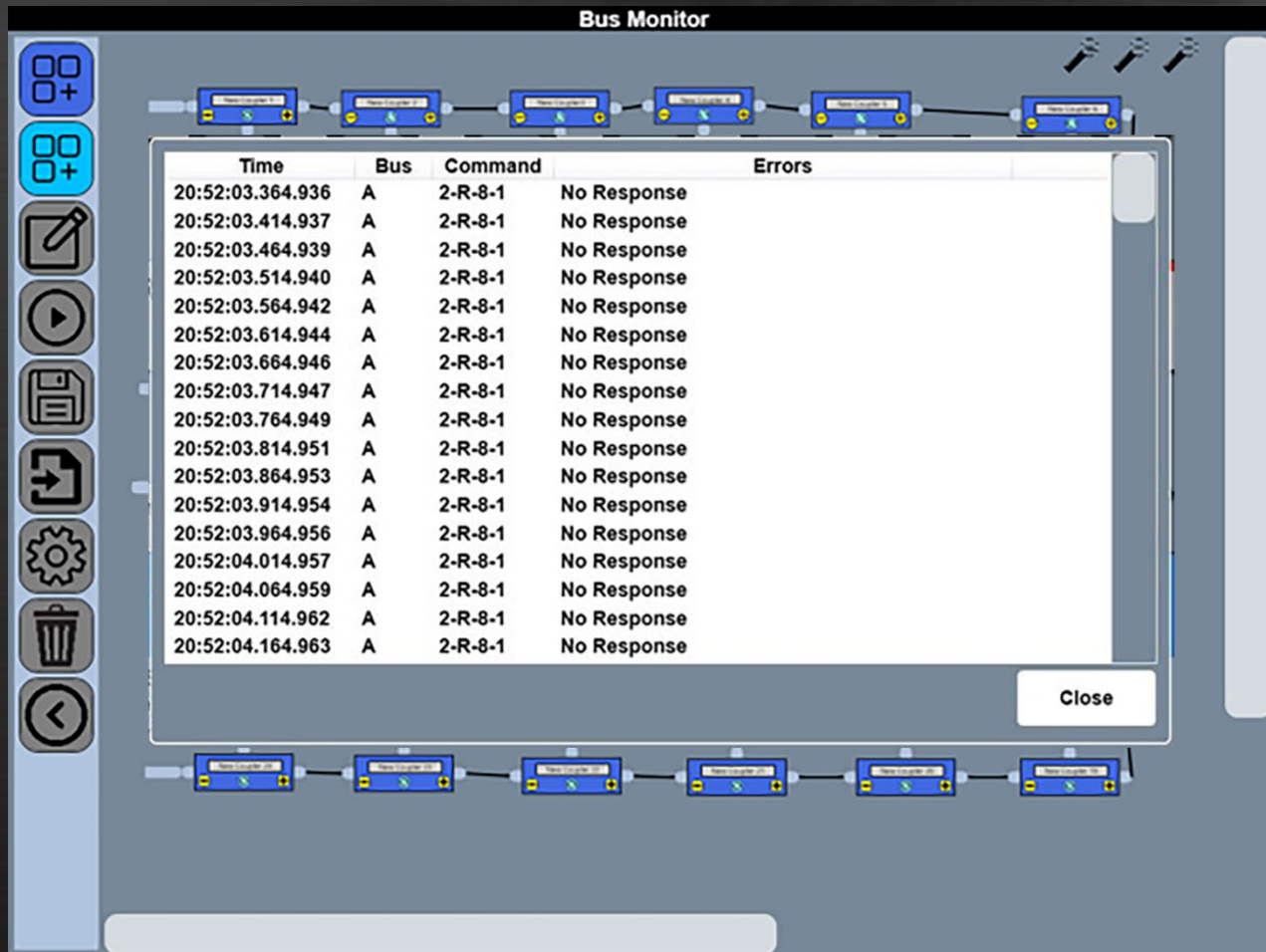

The screenshot shows the Bus Monitor application window. At the top, there is a title bar "Bus Monitor" and a diagram of a bus network with several nodes. Below this is a table with the following columns: Time, Bus, Command, and Errors. The table contains 17 rows of data, all showing "No Response" errors for the command "2-R-8-1" on bus "A". A "Close" button is located at the bottom right of the table area. On the left side of the window, there is a vertical toolbar with various icons for window management, editing, and navigation.

Time	Bus	Command	Errors
20:52:03.364.936	A	2-R-8-1	No Response
20:52:03.414.937	A	2-R-8-1	No Response
20:52:03.464.939	A	2-R-8-1	No Response
20:52:03.514.940	A	2-R-8-1	No Response
20:52:03.564.942	A	2-R-8-1	No Response
20:52:03.614.944	A	2-R-8-1	No Response
20:52:03.664.946	A	2-R-8-1	No Response
20:52:03.714.947	A	2-R-8-1	No Response
20:52:03.764.949	A	2-R-8-1	No Response
20:52:03.814.951	A	2-R-8-1	No Response
20:52:03.864.953	A	2-R-8-1	No Response
20:52:03.914.954	A	2-R-8-1	No Response
20:52:03.964.956	A	2-R-8-1	No Response
20:52:04.014.957	A	2-R-8-1	No Response
20:52:04.064.959	A	2-R-8-1	No Response
20:52:04.114.962	A	2-R-8-1	No Response
20:52:04.164.963	A	2-R-8-1	No Response

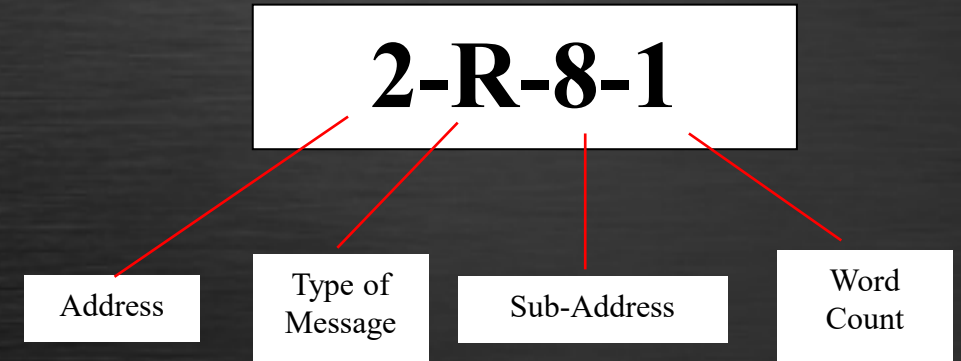

Bus Monitor Error/Filter

You can also filter errors you do not want to appear

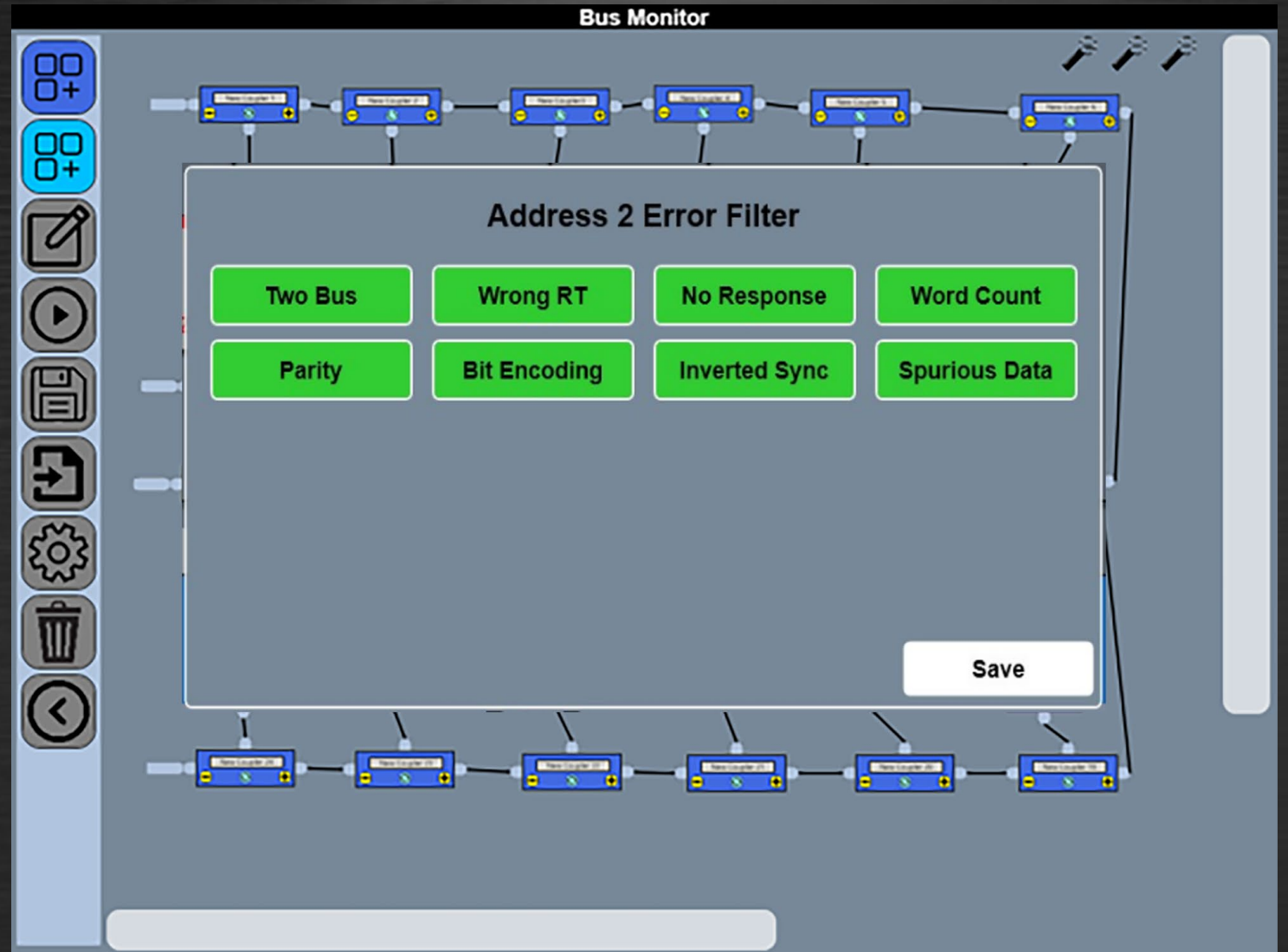

Vector Network Analyzer

Select VNA from the
Splash Screen

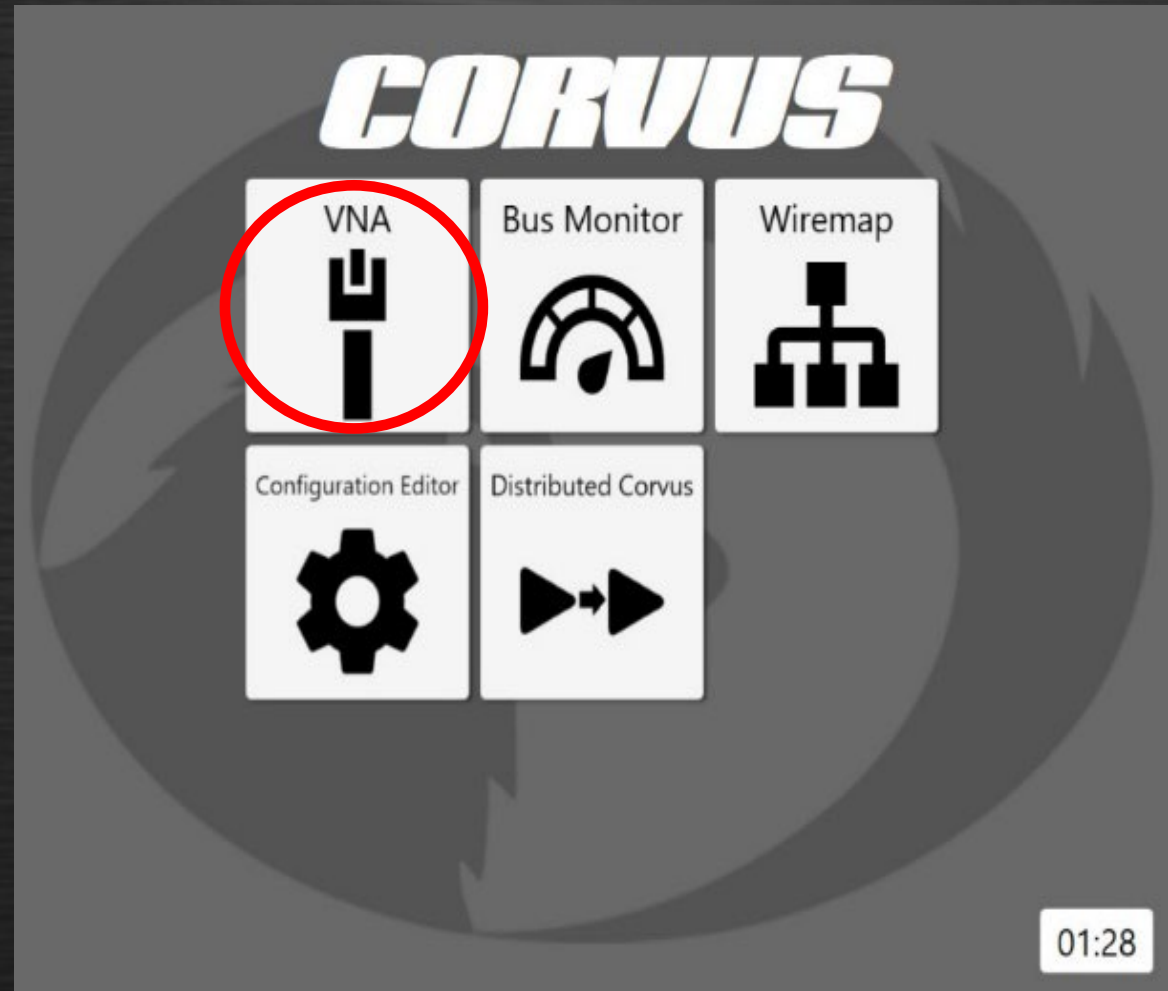

Vector Network Analyzer

CORVUS utilizes a one port VNA that operates in the range of 1 MHz – 6 GHz

There are four tests that can be performed-

- Insertion Loss
- Return Loss
- SWR
- Distance to Fault

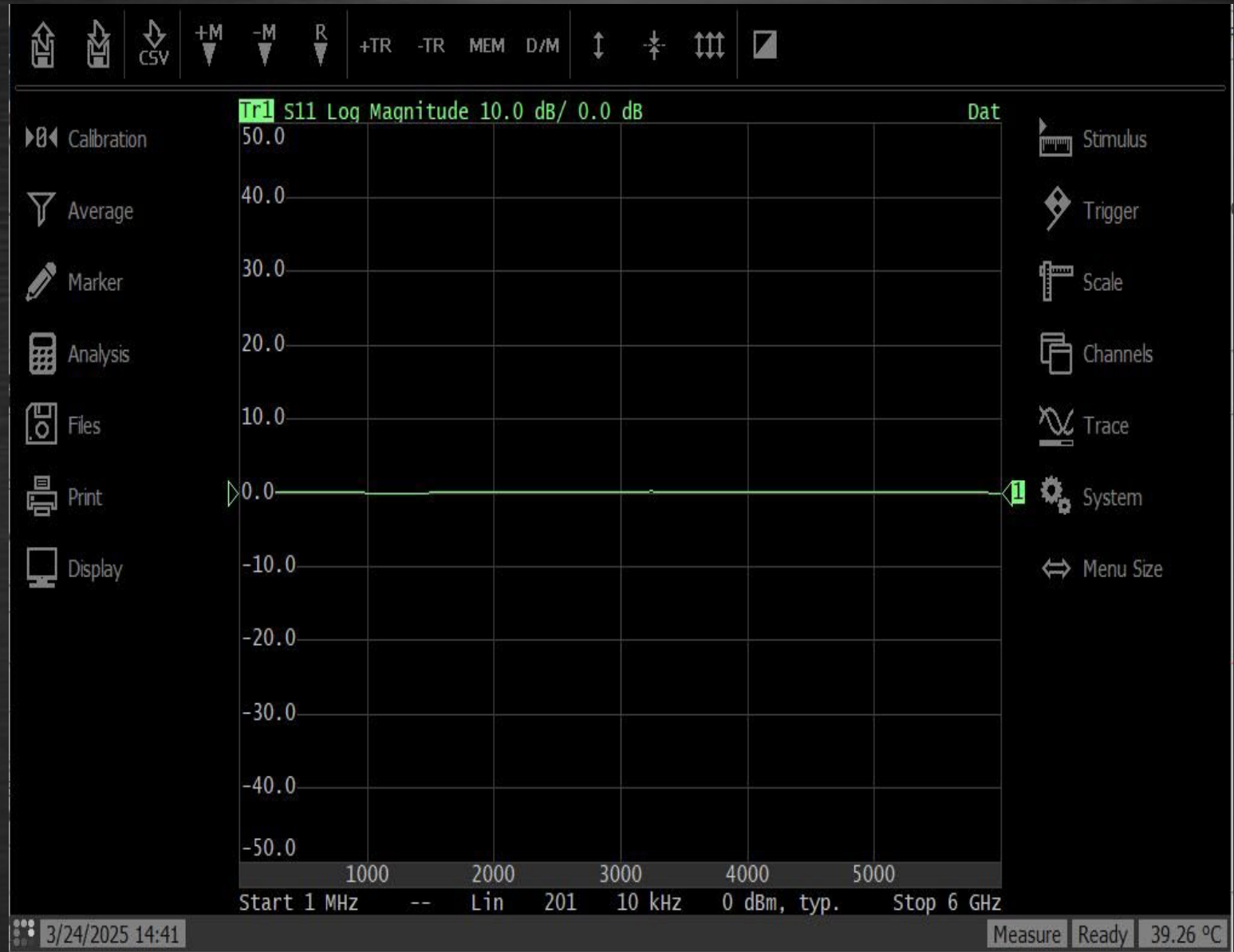

Insertion Loss

1. Set Start and Stop frequencies by selecting Stimulus
2. Connect lead cable and follow Calibration steps
3. Connect DUT
4. Select Trace and change format to cable loss
5. Connect load to opposite end of DUT
6. Save trace data in memory by clicking Trace then Memorize Trace
7. Remove Load from the end of the cable
8. Click Trace > Data Math > Data – Mem
9. Click Marker and add the marker to see dB loss



Return Loss

1. Set Start and Stop frequencies by selecting Stimulus
2. Connect lead cable and follow Calibration steps
3. Connect DUT
4. Select Trace and change format to Log Magnitude
5. Click Marker and add marker to see dB loss



SWR

1. Set Start and Stop frequencies by selecting Stimulus
2. Connect lead cable and follow Calibration steps
3. Connect DUT
4. Select Trace and change format to SWR
5. Click Marker and add marker to see dB loss



Distance to Fault

1. **Set** Start and Stop frequencies by selecting Stimulus
2. **Set** number of points to 2001
3. **Connect** lead cable and follow Calibration steps
4. **Connect** DUT
5. **Ensure** trace format is set to Log Mag
6. **Select** Analysis > Time Domain and change settings to
Unit- Imperial Ft
Reflection Type- One way
Response- Lowpass Impulse
Velocity Factor- VoP of the DUT
7. **Click** set frequency low pass
8. Turn time domain on and click Ok
9. **Click** Marker and add marker to see Ft measurement



Wiremap

Select Wiremap from the
Splash Screen

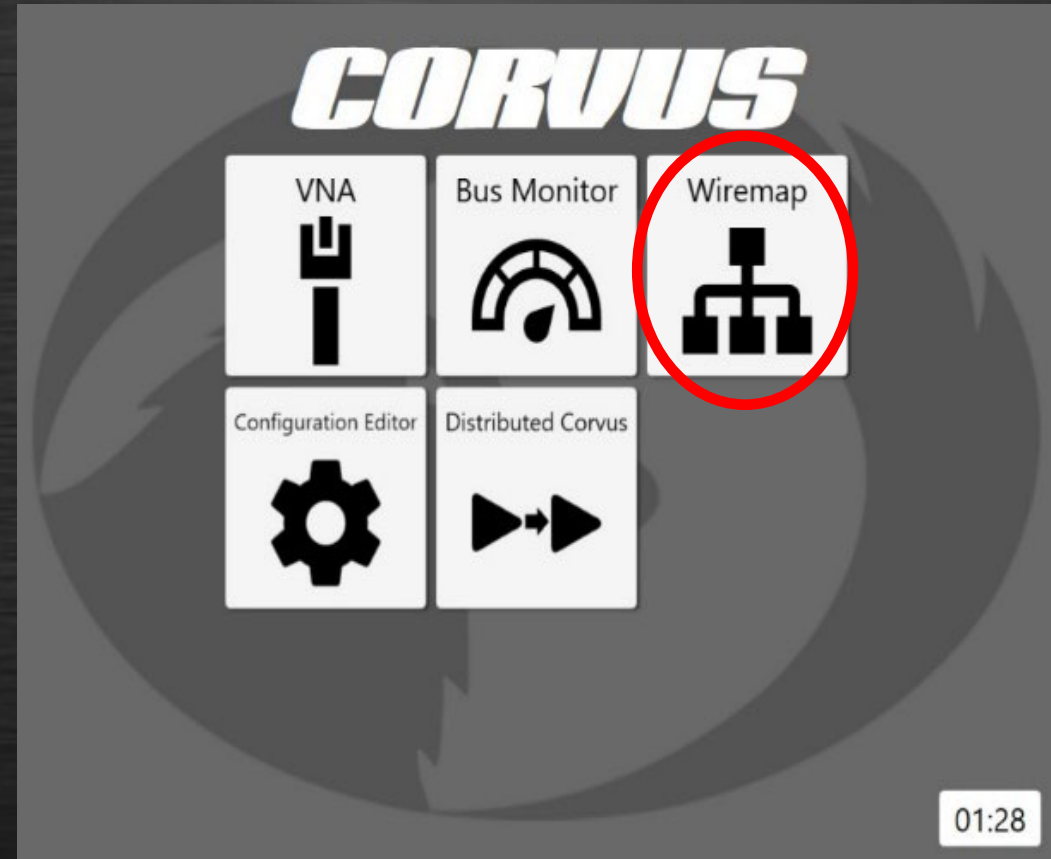

Wiremap

You will need adapter cables to utilize Wiremap

1. Connect the cable you want to test to both ports on the connector panel
2. Select Read, You will get something similar to the screenshot on the top right
3. Select Save to save this as the “golden cable”
4. You can now connect another cable and Select Compare to compare it to the original

If all connections are the same it'll show all Green

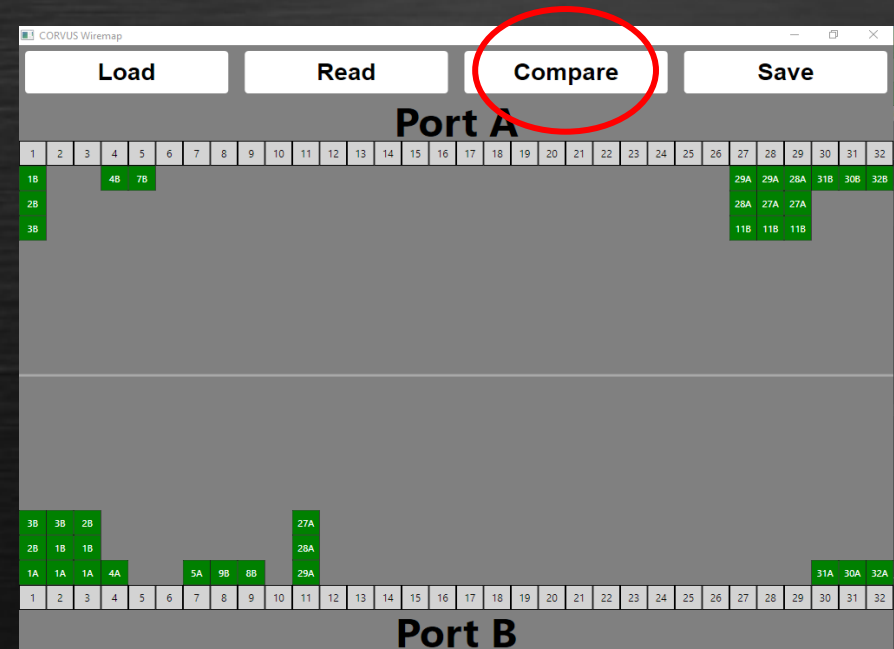
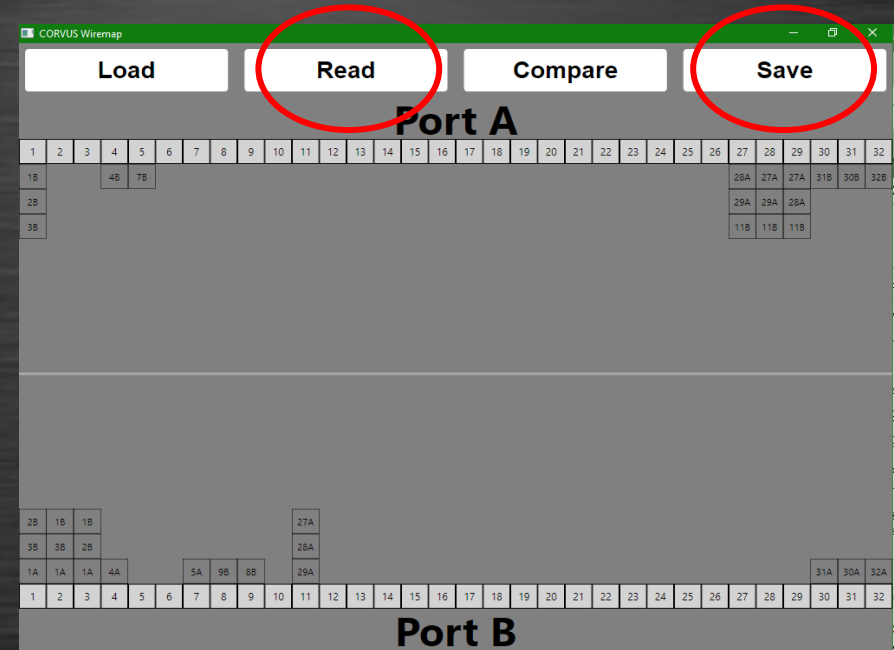

D-CORVUS



Select Distributed CORVUS from the
Splash Screen

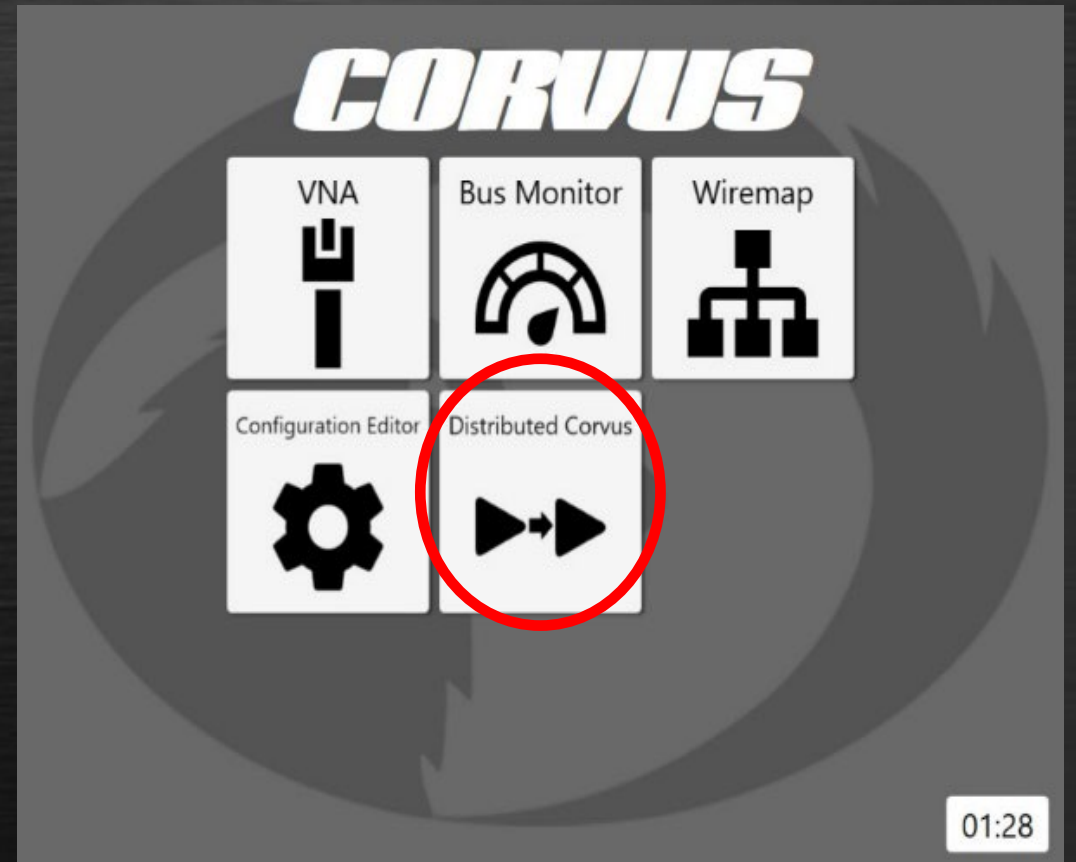

D-CORVUS

Before connecting the D-CORVUS system to the Aircraft bus make sure the bus is in a powered down state. This requires the bus controller and all remote terminals be in the powered down state.

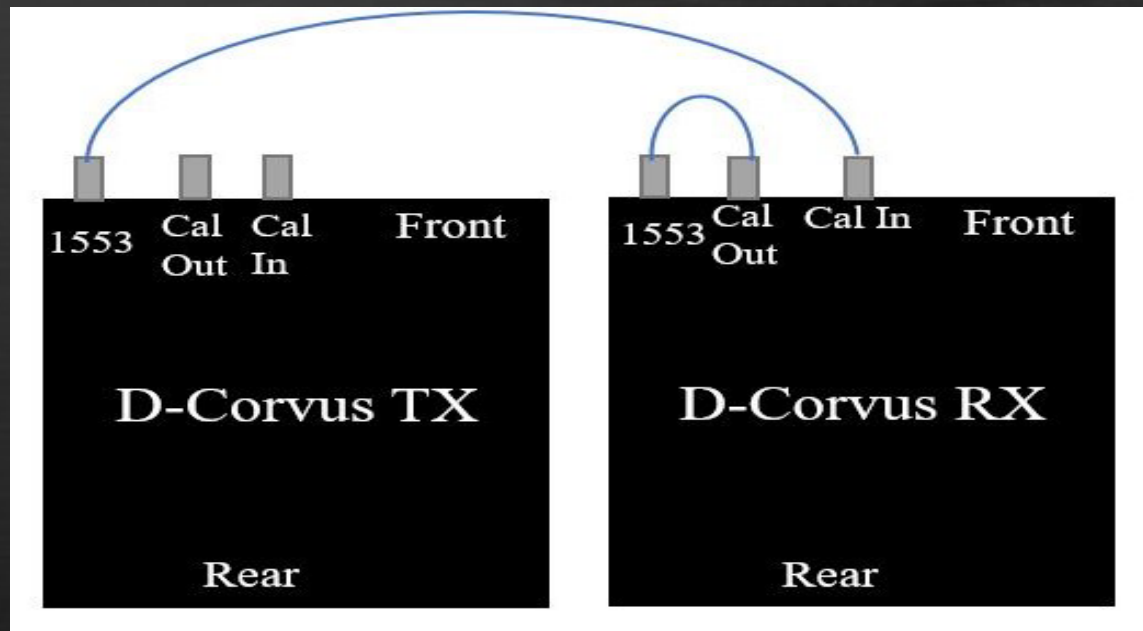

1. **Connect** the Triax cable from Tx Module (MIL 1553 port) to the Rx Module (Cal In port).
2. **Connect** Triax cable to Rx Module ports MIL1553 and Cal Out.
3. **Connect** D-CORVUS RX Module and keyboard to CORVUS via USB Splitter provided

D-CORVUS Cont.

1. Connect TX and RX modules to aircraft stubs
2. **Select Calibrate** in top left corner
3. **Select Calculate Loss** and dB loss should be $12\text{dB} \pm 1\text{dB}$

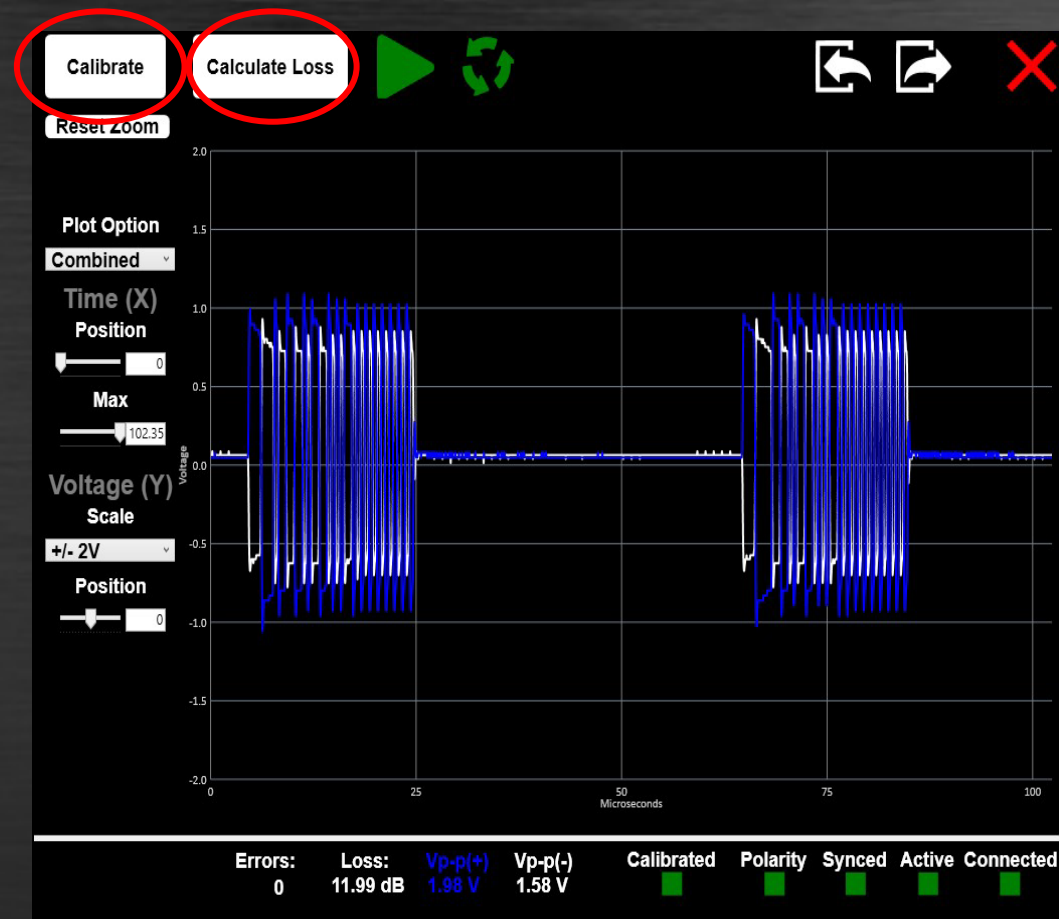

D-CORVUS Aircraft connection

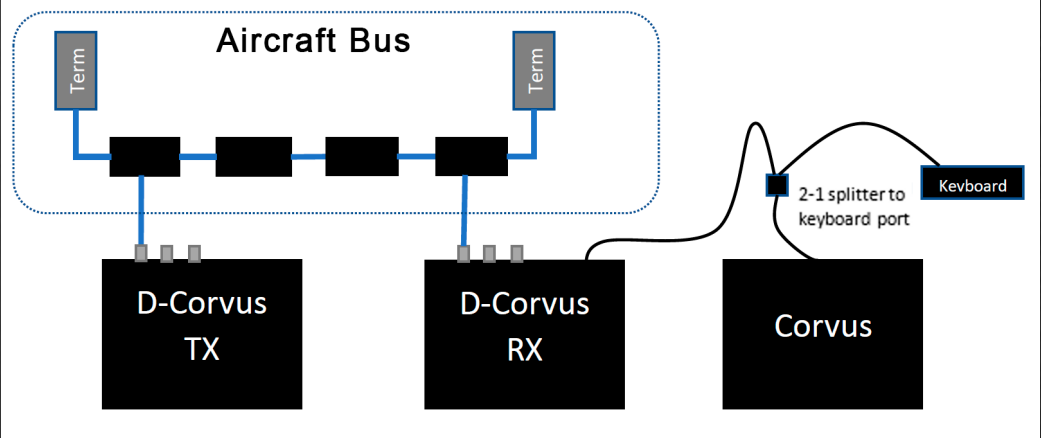

Calibrate

Calculate Loss



Reset Zoom

Calibrates out lead cables

Time (X)

Position



Max



Voltage (Y)

Scale

+/- 2V

Position

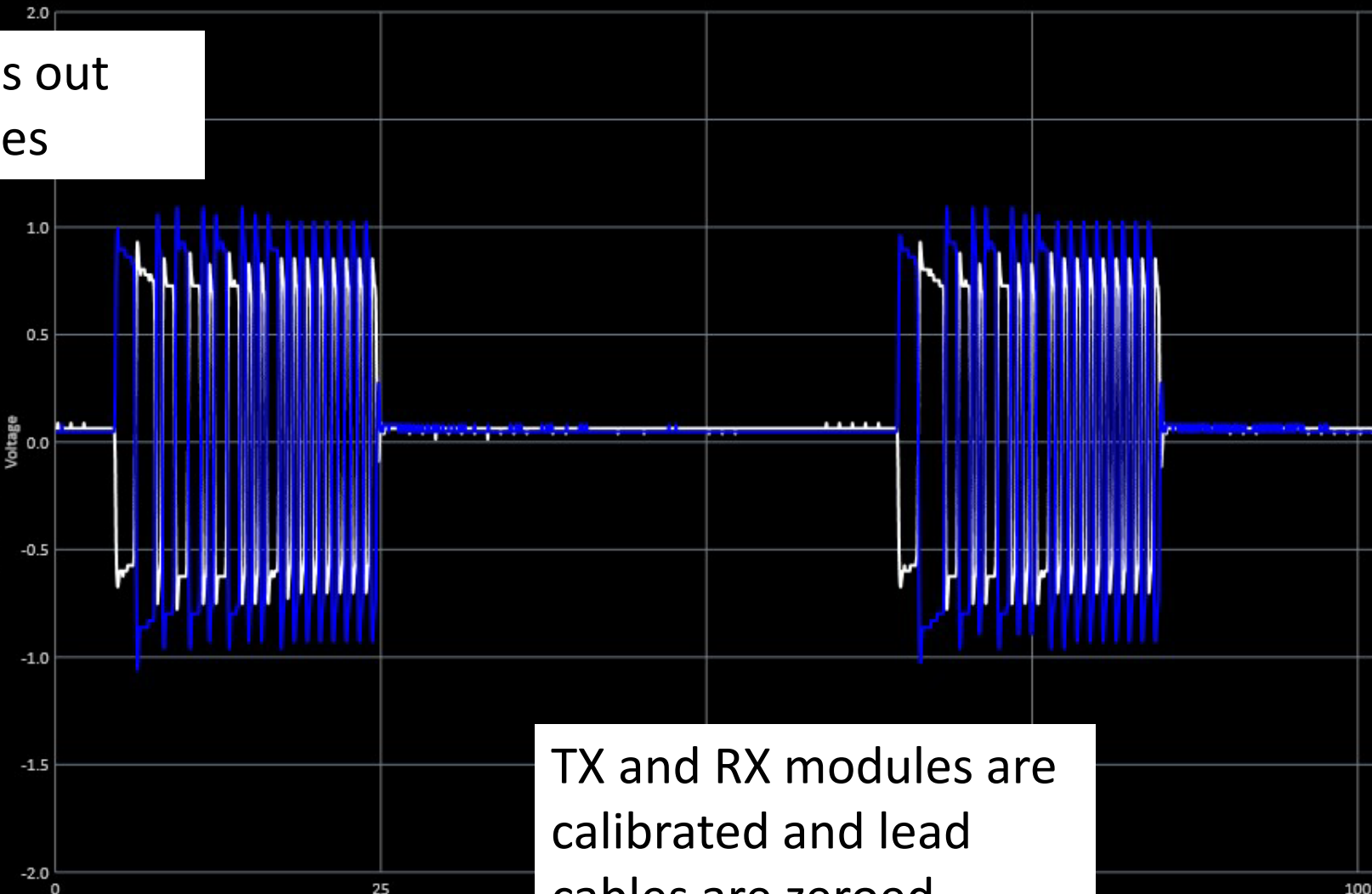

TX and RX modules are calibrated and lead cables are zeroed

Errors: 0

Loss: 11.99 dB

Vp-p(+) 1.98 V

Vp-p(-) 1.58 V

Calibrated

Polarity

Synced

Active

Connected

D-CORVUS

Calibrate

Calculate Loss



Reset Zoom

Plot Option

Split

Time (X)
Position

0

Max

102.35

Voltage (Y)
Scale

+/- 5V

Position

0

Device:

Nav

Device Count: 2

Device Manager

Stress Test

Fast Rendering

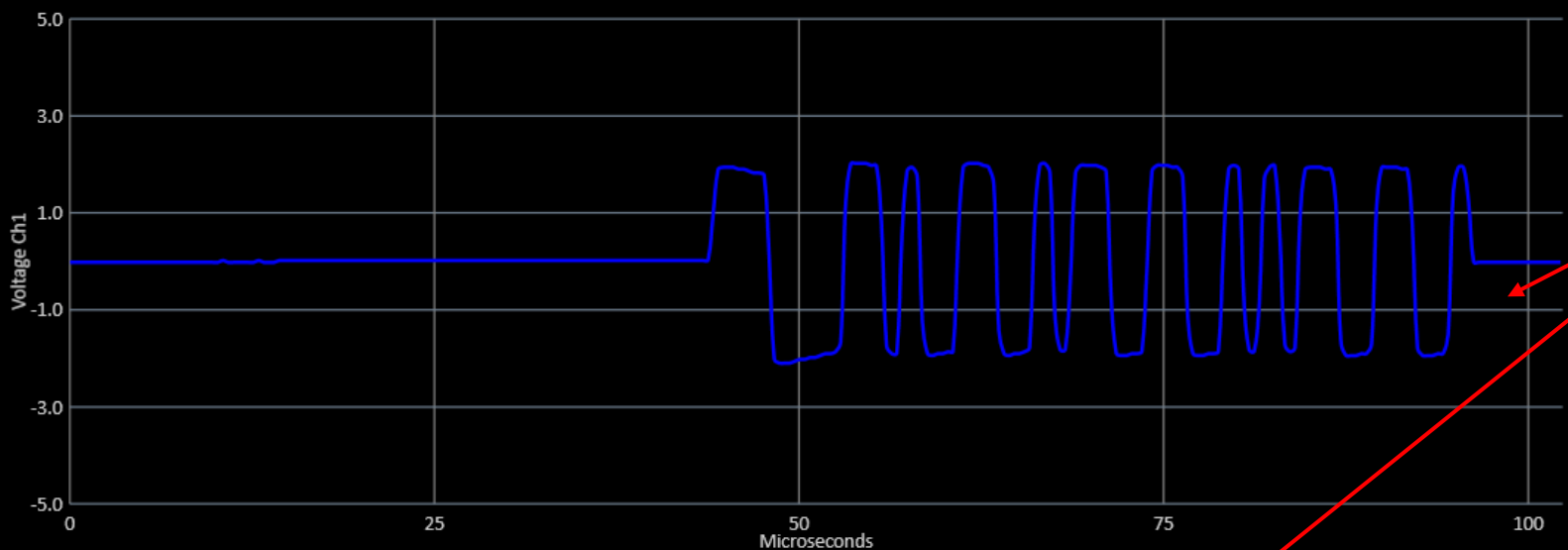

Channel 1 Voltage

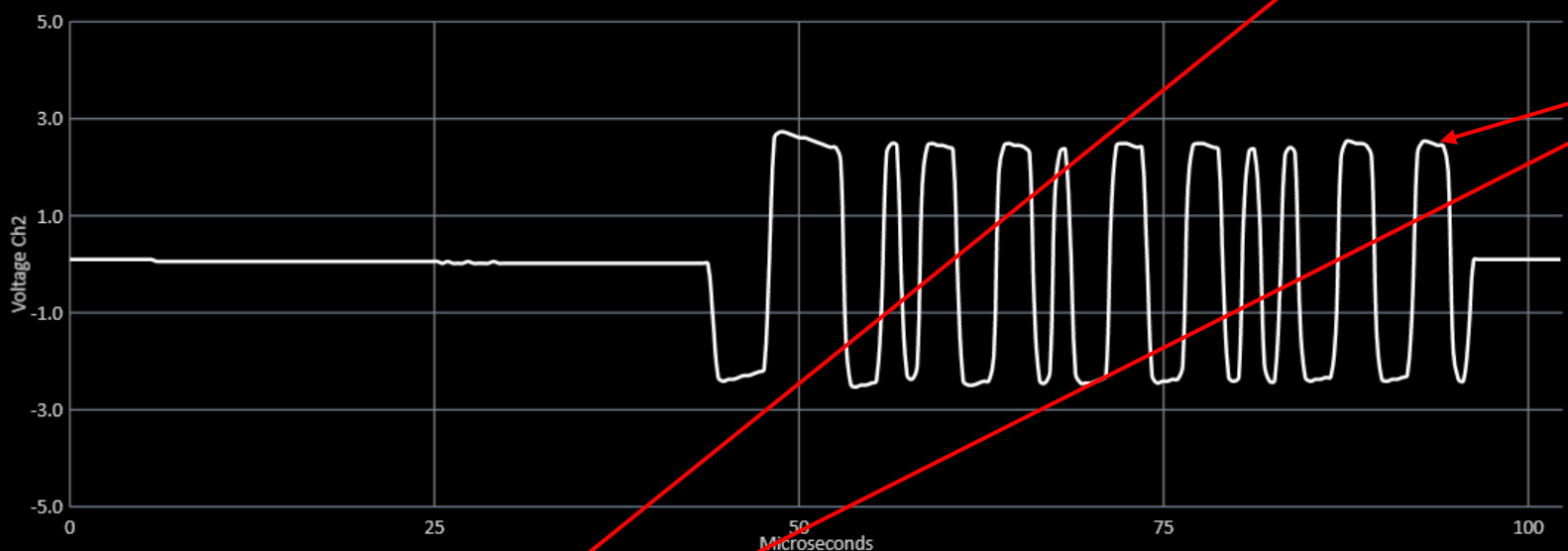

Channel 2 Voltage

Plotting options

Wi-Fi Device Controls

APP Version #

Version 2.0.0.0

Error Menu

Errors: 0

Loss:

Vp-p(+) 3.91 V

Vp-p(-) 4.92 V

Calibrated Polarity Synced Active Connected

Status Indicators

Calibrate

Calculate Loss



Reset Zoom

Plot Option

Split

Time (X)

Position



Max



Voltage (Y)

Scale

+/- 5V

Position



Device:

Nav

Device Count: 2

Device Manager

Stress Test

Fast Rendering

Device Manager

Device Name	Device ID	Code Version	Receiver
TX	2cfe8b4bb6f6	1.0.0.0<Debug>	<input type="checkbox"/>
Nav	2cfe8b4bb736	1.0.0.0<Debug>	<input checked="" type="checkbox"/>

Customizable Device Name

Unchangeable Device ID

MCU Code Version

TX/RX Control

Selected Device: Nav

Latency: -

Device Mode: RX

Back Delete Save

Stress Test



Stress test controls

Export to .CSV button

Start stress test

Export results

Duration (s):
15s

Transmitter:
TX

ID: 2cfe8b4bb6f6

Current Speed:
6.0 Mbit/s

Device Manager

Expand All ▼

Collapse All ▲

Progress:

Stop Test

Back

Nav

1.0 Mbit/s	Errors: 0	Sync: Pass
2.0 Mbit/s	Errors: 0	Sync: Pass
3.0 Mbit/s	Errors: 0	Sync: Pass
4.0 Mbit/s	Errors: 0	Sync: Pass
5.0 Mbit/s	Errors: 65535+	Sync: Fail
	15s	6.0 Mbit/s
	15s	7.0 Mbit/s
	15s	8.0 Mbit/s

Running Stress Test for device "Nav"

Additional stress tests will show up here as devices connect

Stress Test Export

The screenshot shows a Microsoft Excel spreadsheet titled "2025-06-10_15-01-58_stress-test-results.csv". The spreadsheet contains a table with the following data:

	A	B	C	D	E	F	G	H	I	J	K	L	M	N	O
1	Device ID	Name	Bit Rate	Duration	Sync	Errors									
2	2cfe8b4bb736	Nav	1	15	Pass	0									
3	2cfe8b4bb736	Nav	2	15	Pass	0									
4	2cfe8b4bb736	Nav	3	15	Pass	0									
5	2cfe8b4bb736	Nav	4	15	Pass	0									
6	2cfe8b4bb736	Nav	5	15	Fail	65535									
7	2cfe8b4bb736	Nav	6	15	Fail	65535									
8	2cfe8b4bb736	Nav	7	15	Fail	65535									
9	2cfe8b4bb736	Nav	8	15	Fail	65535									
10															
11															
12															
13															
14															
15															
16															
17															
18															
19															
20															
21															
22															

The status bar at the bottom indicates "Ready" and "Accessibility: Unavailable". The zoom level is set to 100%.

Distributed CORVUS Wi-Fi Network

- Multiple D-CORVUS devices may be connected at once.
- Each D-CORVUS device will automatically connect to the access point.
- The access point will be controlled by CORVUS to send commands to each device.
- Specific devices can be selected to plot data at that location.

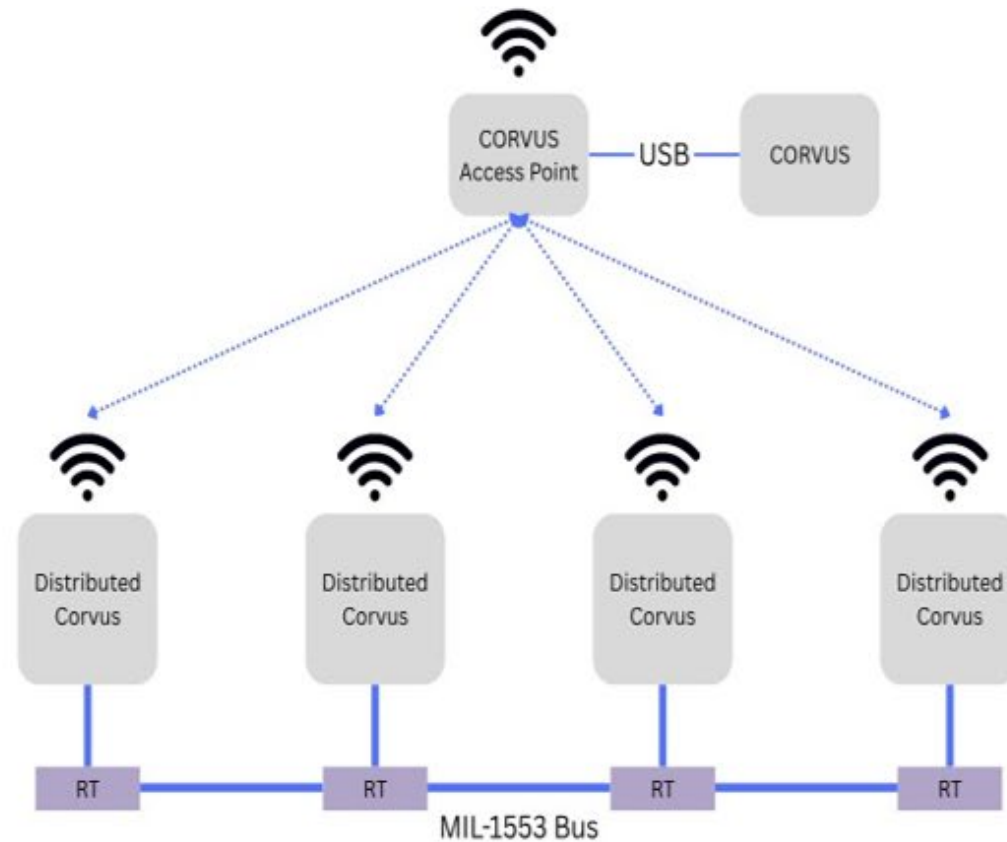

Use Cases

ISSUE	FUNCTION	APPROACH
1553 Bus Errors	Bus Monitor	Detect and capture R/T indicating RED
Reverse Polarity	D CORVUS	RX Polarity indicates RED
Cable Open and Shorts	D CORVUS VNA	Use TX and RX with D CORVUS to ensure signal path is complete. Both open and short conditions will be apparent. Use VNA in Distance to fault mode for determining distance on cable assembly.
Coupler Fault	D CORVUS	Use TX and RX on Stubs, run D CORVUS to measure insertion loss
Pushed Pins	Wiremap	Use function to determine which pin is disconnected in cable
Antenna Mismatch	VNA	

1553 Bus Monitor Use Case

1. Locate 1553 Bus PRI and SEC ports on A/C
2. Attach adaptor cable to CORVUS 1553 PRI / SEC
3. Start Bus Monitor with Icon shown by Yellow Arrow
4. Run CORVUS Bus Monitor from the Splash Screen and Load proper Bus Configuration file

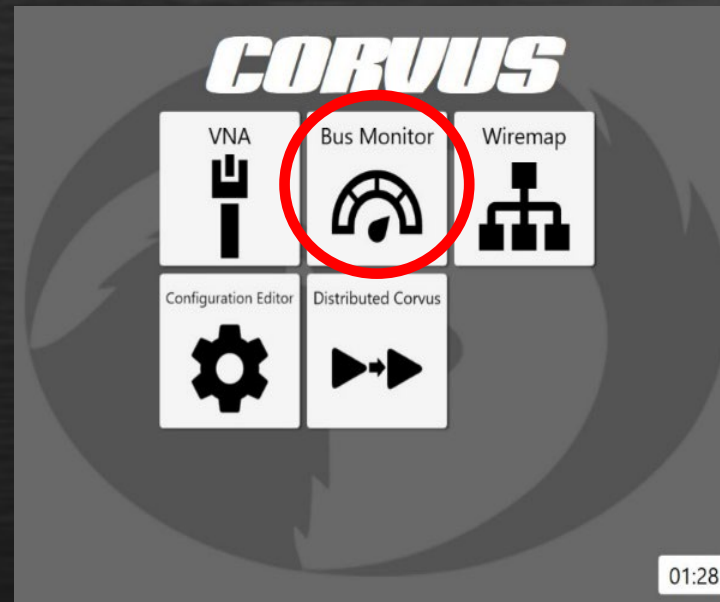
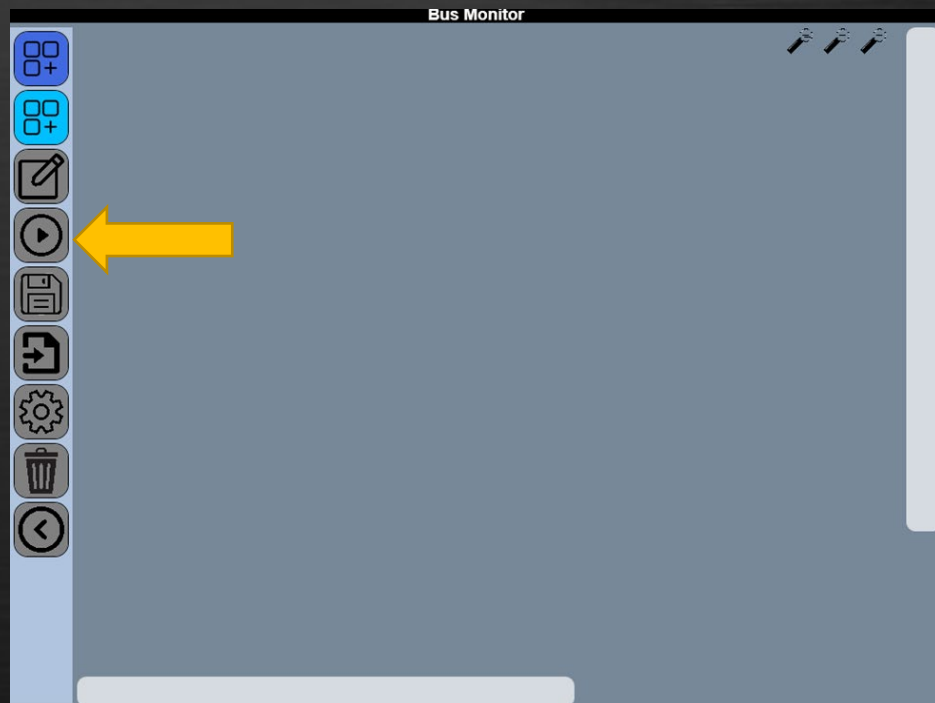
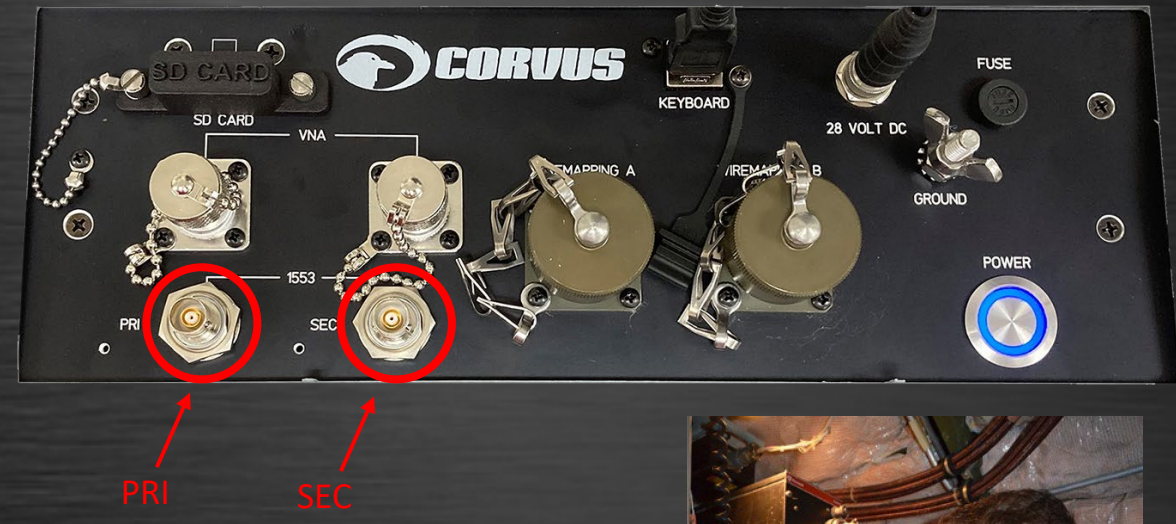

1553 Bus Monitor Use Case

5. Monitor R/T for errors (red) and view the error by selecting the R/T with red indicators.
6. Typical errors are “No Response” or Parity Error
7. Replace or repair as needed.

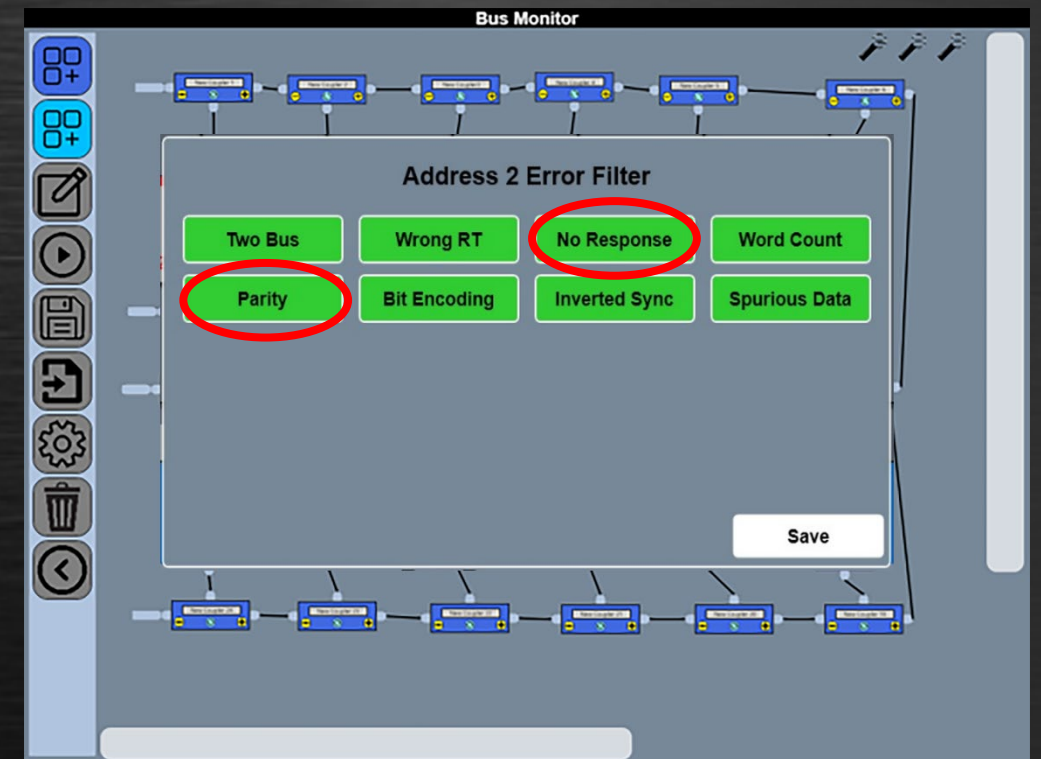
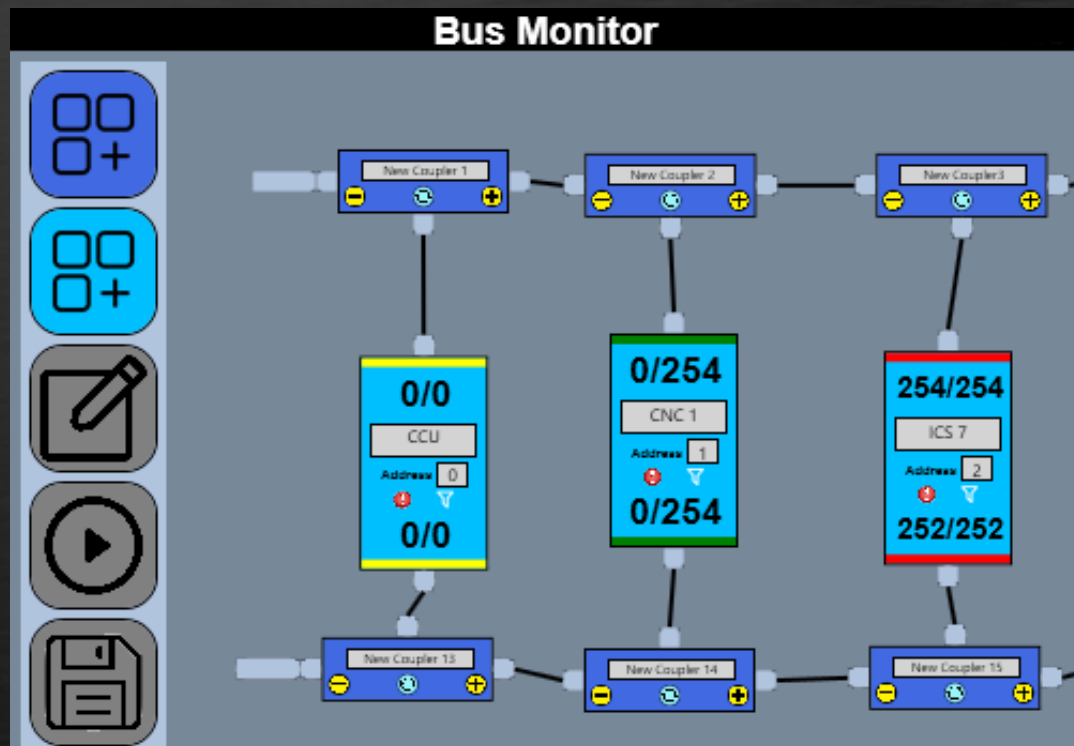

1553 Stub Coupler Use Case

1. Locate 1553 Bus STUB PRI and SEC ports on inactive A/C. Disconnect R/T if no test port.
2. Connect TX to A/C, repeat for RX on same bus (stub)
3. Using WiFi or cable (USB-Keyboard) from CORVUS to RX, ensure all modules are on and Green. (LEDs)
4. Start D CORVUS application from CORVUS Splash Screen
5. Observe mimic 1553 Test Pattern as seen in RX trace.
6. Compare to TX and prior traces (if available)
7. Coupler insertion loss is displayed as shown.

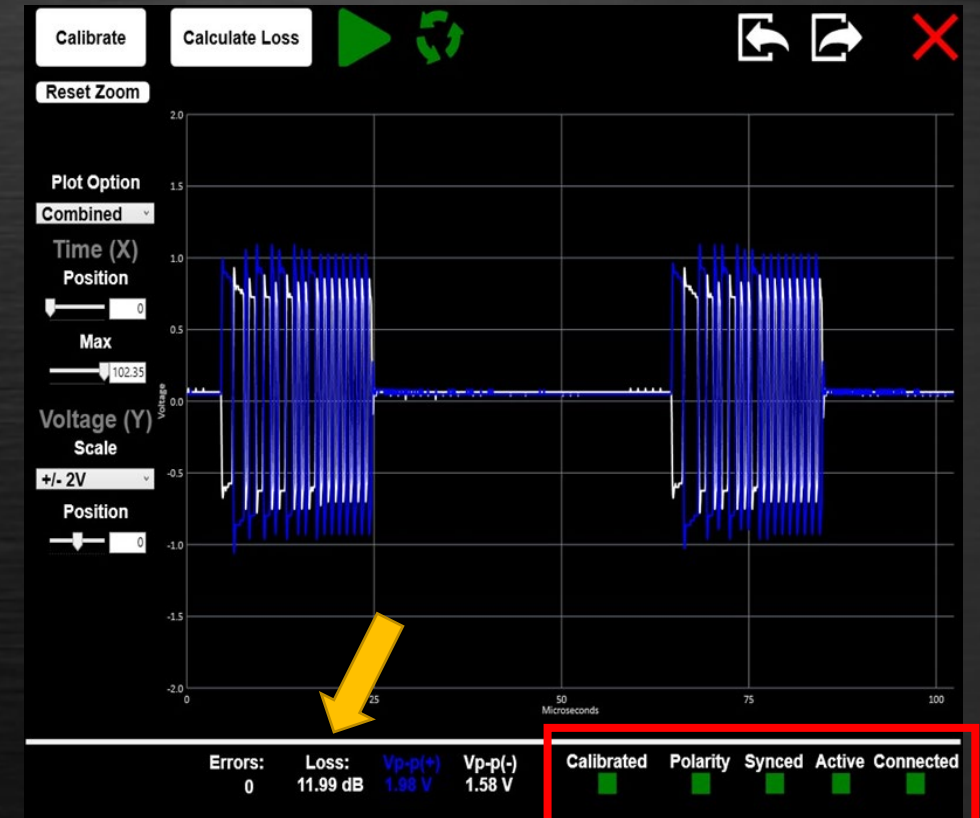
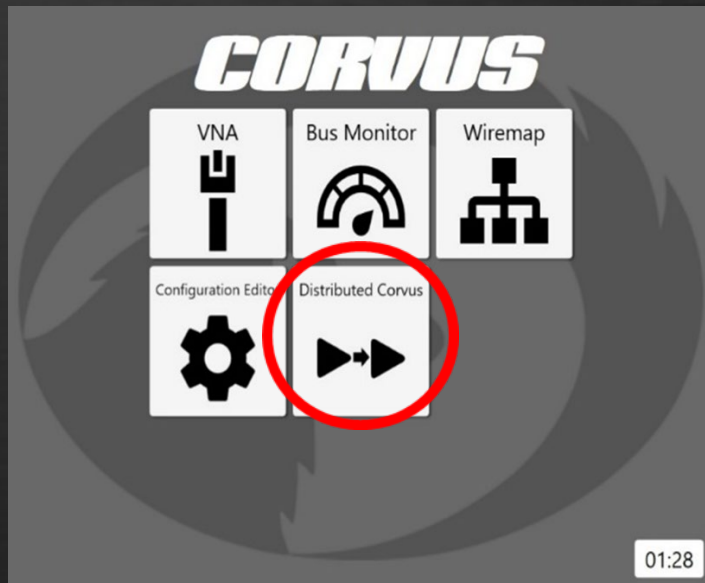

VSWR USE CASE – WHIP ANTENNA

Whip antenna operational range
225 MHz – 450 MHz

Lead Cable attaches to VNA Port

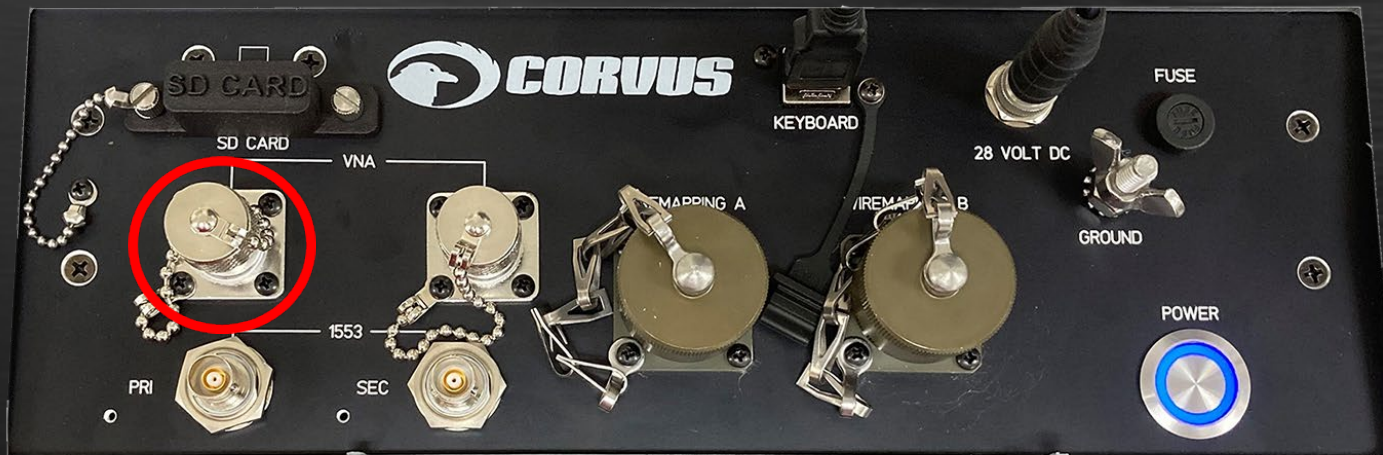

VSWR Use Case 1

1. Select S₁₁
2. Select Trace & Format
3. Set Start and Stop frequencies by selecting start & stop and entering desired frequencies
4. Follow Calibration steps (next)



VSWR Use Case 2

Calibration Steps

1. Connect N611 open select open F
2. Connect N611 short select short F
3. Connect N611 load select load
4. Select Apply
5. Lead cable is calibrated out



VSWR Use Case 3

1. Connect the end of the lead cable to the whip antenna being tested
2. Select Trace and ensure format is SWR
3. SWR should be below 2:1 in 225 – 450 MHz range for PASS





Our products and services save time and money for DoD and private industry by developing novel, advanced systems applications and test tools tailored for a wide range of specific requirements.