

Malone NY: Noise

From the desk of

Michael J. Fournier



April 8, 2018

Via Email

Hon. Kathleen H. Burgess, Secretary to the NYS PSC Siting Board

Re. Case No. 17-F-0602: Application of Franklin Solar, LLC, for a Certificate of Environmental Compatibility and Public Need Pursuant to Article 10 of the Public Service Law for Construction of a Solar Electric Generating Facility Located in the Town of Malone, Franklin County.

Dear Hon. Burgess,

On behalf of Friends Against Rural Mismanagement (FARM), I would like to submit this comment as a filed document to the DMM, responding to the PIP filed by Franklin Solar (Geronimo Energy) for case no. 17-F-0602, hereafter referred to as Geronimo.

As mentioned in previous correspondence, I head Friends Against Rural Mismanagement (FARM), being a group of individuals who live either within the boundaries of the project or within 5 miles of the Town of Malone.

On page 7 of its revised PIP, dated November 2017, Geronimo writes:

The Project will sit on approximately 950 acres of private land. With extensive experience developing solar projects in agricultural areas and in and adjacent to communities, Franklin Solar carefully considers the size, location, and environmental impact of the project, as well as local politics, landscapes, and land uses. Franklin Solar anticipates that the Project will have minimal impact on its neighbors, nearby communities, and surrounding landscapes. The proposed Project will be

relatively low in height, estimated to be no more than 15 feet, will not emit air or water pollution, will have no odors, and will produce minimal noise.

Amid yards of self-congratulation and sanguine assurances, most of it dissected and discredited in our previous submissions, there is the vague promise: “The proposed Project . . . will produce minimal noise.”

“Minimal noise.” What’s this supposed to mean? Let’s take a closer look. Here’s a schematic by GE of a solar project with all the latest, state-of-the-art whistles & bells:

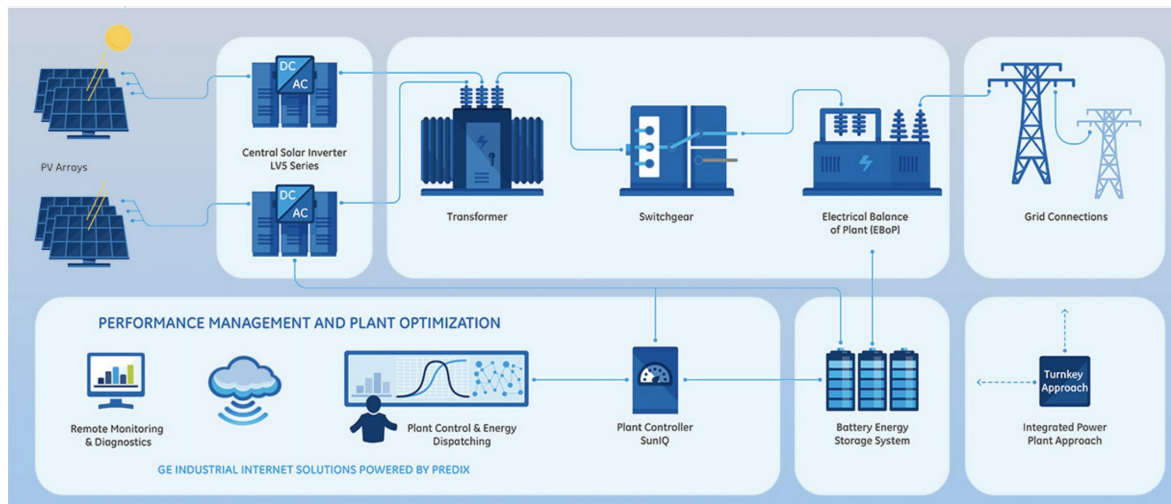

Notice all that power conversion equipment in the top row: inverters (DC to AC), transformers, switchgears, electrical balance of plant, plus battery energy storage systems in row 2. All this apparatus makes noise. Complicated noise.

Consider the inverters. I am attaching a paper on inverter noise, “Harmonics & Noise in Photovoltaic (PV) Inverters and the Mitigation Strategies.”¹ Start reading. Even a layman immediately realizes that inverters generate high frequency noise of various sorts and complexities, often with weird harmonics. In another article the German inverter manufacturer SMA Solar Technology describes its experience sleuthing out persistent inverter noise emissions, analyzing:

- structure-borne noise transfer paths
- transfer of airborne noise and its effects
- noise caused by vibrations

¹ Soonwook Hong & Michael Zuercher-Martinson, “Harmonics & Noise in Photovoltaic (PV) Inverters and the Mitigation Strategies,” Solectria Renewables, n.d. One can find innumerable such papers on the Web.

- resonance frequency testing²

And that's not even considering the other machinery, including the transformers and ESS (Energy Storage Systems).

The take-home message being: It requires a lot of tinkering and fine tuning on a regular basis to dampen, shield, cancel, suppress, filter, or otherwise get rid of this (mostly) electrically-generated cacophony. When industrial-scale PV plants are built far from homes, nobody cares about the noise. The problem is, Geronimo wants to build its huge plant next to homes, including mine, and my neighbors and I don't wish to be guinea pigs for its intractable and elusive noise emissions.

Inverter Noise



A few words about ESS (Energy Storage Systems). Geronimo holds open the option of including ESS modules in its project (pp. 7-8 of the rev. PIP). So-called energy storage systems are large storage containers housing racks of (generally) lithium batteries (famous for being temperamentally combustible), with the container heated or cooled, depending on the season, by large HVACs (Heating, Ventilation, Air Conditioning). HVACs are notorious for their infrasound and low frequency noise. Noise engineers seem agreed they are the source of what's often called Sick Building Syndrome. The ESS, by the way, are used to smooth the flow of power to the grid. Wind and solar companies hope for the day when ESS can store large quantities of electricity and release it over days or weeks, but all this is far in the future, if ever. Right now, ESS are not even

² SMA Solar Technology, "Reducing Noise in PV Power Plants: Comprehensive Testing Points the Way to Significantly Reducing Noise from Central Inverters," attached.

close to accomplishing this.³

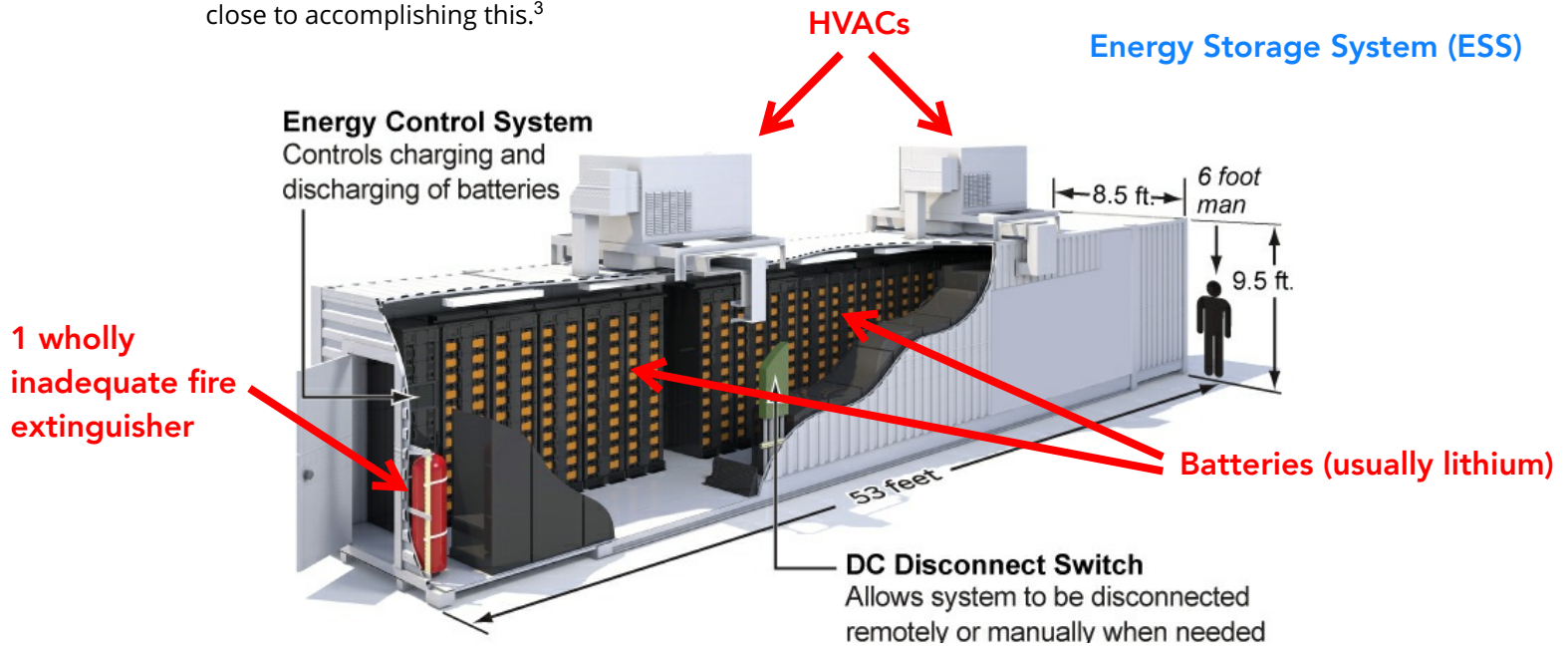

Take a look at this table showing inverter noise emissions in dBA from 4 inverters at a solar plant near West Linn in Clackamas County, Oregon. The noise level at 50 feet is well above ambient noise on a typical summer day. At greater distances (see rows 4 & 5), the noise emissions are still over ambient levels.⁴

Table 3. Inverter Noise Levels at Various Distances with Four Inverters at IM7

Location of Source (number of inverters)	Noise Level at 50 Feet	Receiver Location	Distance from Source to Receiver	Noise Level from Inverters at Receiver
	dBA		(feet)	Leq/dBA
I10 (3)	64	RM6	800	40
IM5 (3)	64		360	47
IM7 (4)	65		2040	33
I10 (3)	64	RM8	1280	36
IM5 (3)	64		1800	33
IM7 (4)	65		216	52
I10 (3)	64	R11	224	51
IM5 (3)	64		544	43
IM7 (4)	65		1336	36

“At 150 feet,” declare the Geronimo salesmen, “sound from a PV system is at a background level,” citing a 2012 report by Tech Environmental. (We have our doubts about Tech Environmental, whose wind turbine noise predictions for Wellfleet MA were thoroughly discredited some years

³ See, for instance, Roger Andrews, “Is Large-Scale Energy Storage Dead?” www.Euanmearns.com (April 8, 2016).

⁴ Damian Waco, “Electrical Noise Emissions from a Solar PV Inverter/Charger, www.CivicSolar.com (2012).

ago.⁵) Background level on Geronimo's 950 leased acres in Malone is typically 20-25 dBA.



Common Solar Concerns

SOUND

- At 150 feet sound from a PV system is at a background level

"Study of Acoustic and EMF Levels From Solar Photovoltaic Projects", Prepared for: Massachusetts Clean Energy Center. Prepared by: Tech Environmental, Inc. December 17, 2012

DECOMMISSIONING

- Equipment removal and site restoration, minimal concrete usage

WATER USAGE

- Module cleaning not anticipated



Residents on Martha's Vineyard were given the same assurances that Geronimo is peddling to us:

Smith Hollow is a quiet neighborhood in Edgartown [MA] where the ambient sounds include distant traffic and breeze moving through the trees.

But this past summer [2014], the installation of a new municipal solar array added a new sound to the mix: incessant humming that all but drowns out the other sounds at some Smith Hollow residences.

As soon as the solar project went live, inverters, the part of the system that converts direct current from the sun to alternating current, began emitting noise on sunny days. Neighbors complained, and the town hired an expert to investigate.

The inspection revealed that the sound coming from the inverters exceeds ambient sounds in all eight octaves by a significant margin, according to a report discussed by the town selectmen Monday.

"The sound from the inverters is clearly in violation of the Mass. DEP Noise Policy, and also constitutes a noise nuisance, in my opinion, based on the sound level measurements reported here," wrote Lawrence G. Copley, a sound engineer, in the noise assessment he presented to the town.

⁵ Calvin Luther Martin, "Why Wellfleet Will Get Wind Turbine Syndrome," www.WindTurbineSyndrome.com (Nov 7, 2010).

CVEC [Cape & Vineyard Electric Cooperative] says they did not anticipate a noise issue. . . . "I feel a little bit embarrassed for not knowing that this was going to be a problem because they are classically not very noisy but we clearly have a noisy inverter or more than one that we need to remedy," said Liz Argo, special projects coordinator at CVEC. "So I just wanted to let you know that there are situations where this is not a problem."

But resident James Cimeno said Monday that he and others did raise sound as a possible concern, but were assured that it would not be a problem. "Right from the start I suggested that they move them because of noise," he said. "We were told they weren't going to make any noise."⁶

Liz Argo and CVEC are the same gang who told Falmouth MA residents that industrial wind turbines would be noiseless, despite repeated warnings from town residents and outside experts that turbines make unbearable infrasonic noise—unbearable for migraineurs. After years of town hearings and court cases, and a number of people being forced to leave their homes, the courts have shut down the turbines for this very reason.



Those of us living cheek-by-jowl with Geronimo's solar project, with its inverters, transformers, switchgears, electrical balance machinery, and possibly HVAC cooled/heated electric storage systems, don't want to go through what «les miserables» on Martha's Vineyard experienced.

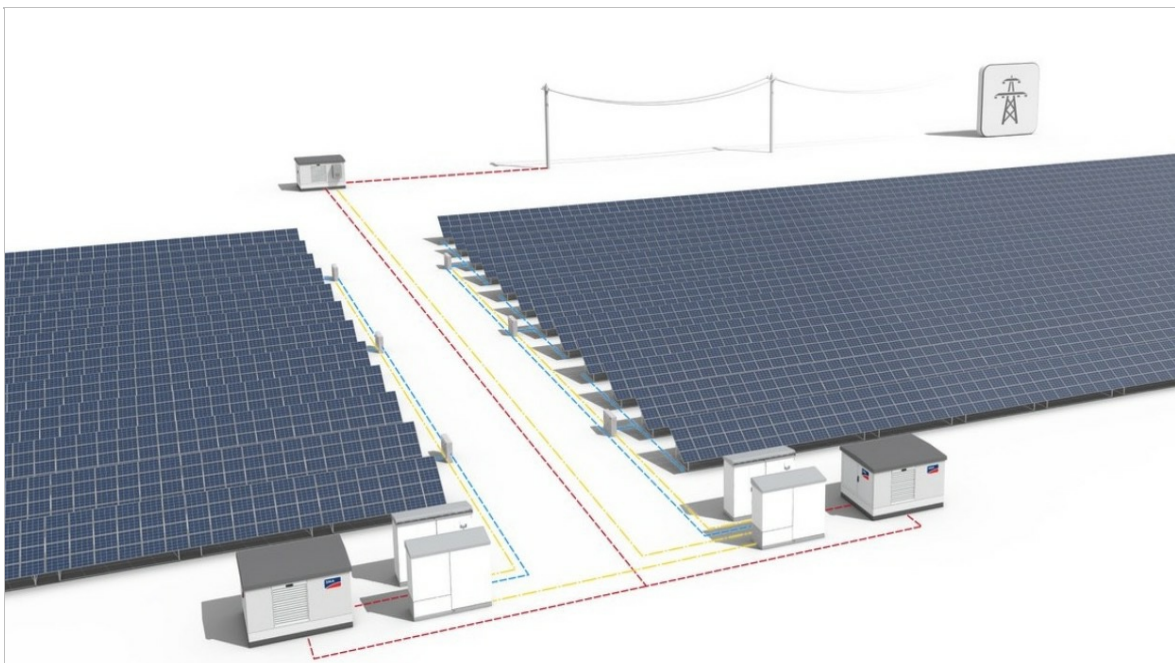

⁶ Olivia Hull, "Solar Panels Create Noise Nuisance in Edgartown," Vineyard Gazette (Martha's Vineyard), Sept 24, 2014.

Finally, consider this from Ontario, Canada in 2011:

There wasn't an open chair at the Simcoe Solar Farm Awareness Project (SSFAP) symposium held at the Coldwater community centre on Saturday. Approximately 200 people packed into the upper hall to hear the SSFAP presentation on the importance of preserving agricultural land from large-scale solar farms and issues surrounding the construction of these projects.

There are 10 large-scale solar panel projects proposed by Recurrent Energy, a San Francisco-based power producer, in Simcoe County, located in Oro-Medonte, Severn, Springwater and Tay townships.

Frank Coyle, retired civil engineer and former general manager for Simcoe Hydro [Ontario, Canada], spoke about his experience building municipal substations for the production of electricity. He said the proposed transformers on these solar panel farms are basically like a big substation. The concept is the same, they are moving electrons down the wire to produce energy, and with that process comes noise. "There's an awful hum to it," he said. "If you put that hum in a rural territory, you will hear it for miles. It becomes the most annoying sound that you will ever experience. . . . It's a constant hum that you will always hear."⁷

Sincerely,



Michael J. Fournier
President of FARM and party to case no. 17-F-0602

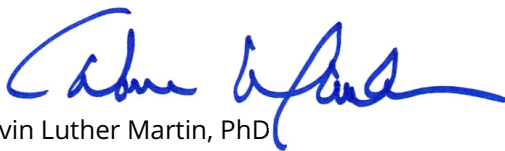

Calvin Luther Martin, PhD
Member of FARM and party to case no. 17-F-0602

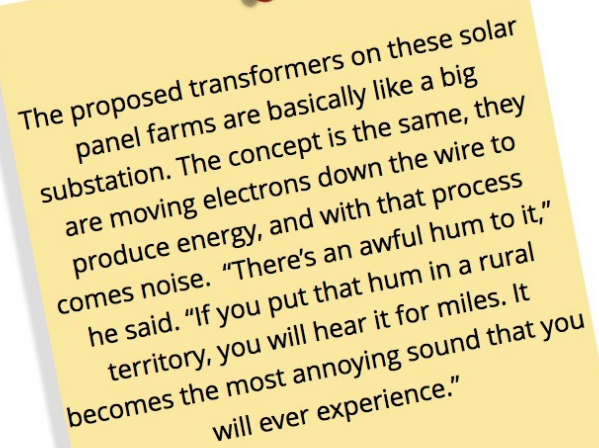

The proposed transformers on these solar panel farms are basically like a big substation. The concept is the same, they are moving electrons down the wire to produce energy, and with that process comes noise. "There's an awful hum to it," he said. "If you put that hum in a rural territory, you will hear it for miles. It becomes the most annoying sound that you will ever experience."

⁷ "Solar Farm Forum Gets Heated," Orillia Packet & Times (Ontario), Jan 31, 2011.

From The Desk Of

Michael J. Fournier



April 8, 2018

Appendix

to

Fournier to Burgess 4-8-18

Re. Case No. 17-F-0602: Application of Franklin Solar, LLC for a Certificate of Environmental Compatibility and Public Need Pursuant to Article 10 of the Public Service Law for Construction of a Solar Electric Generating Facility Located in the Town of Malone, Franklin County.

This appendix consists of all the articles referred to in DMM submission, "Fournier to Burgess 4-8-18." Articles are attached in "footnote sequence," clearly marked with a bold stamp at the top of each article. (Thus the first article corresponds with footnote 1. The second with footnote 2. Etc.)

Footnote 1

Soonwook Hong, Ph. D.
Michael Zuercher-Martinson

Harmonics and Noise in Photovoltaic (PV) Inverter and the Mitigation Strategies

1. Introduction

PV inverters use semiconductor devices to transform the DC power into controlled AC power by using Pulse Width Modulation (PWM) switching. PWM switching is the most efficient way to generate AC power, allowing for flexible control of the output magnitude and frequency. However, all PWM methods inherently generate harmonics and noise originating in the high dv/dt and di/dt semiconductor switching transients. In order to reduce harmonics and switching noise, external filtering needs to be added. The following conceptual figure shows how the AC output voltage is generated at the inverter power stage output using PWM switching.

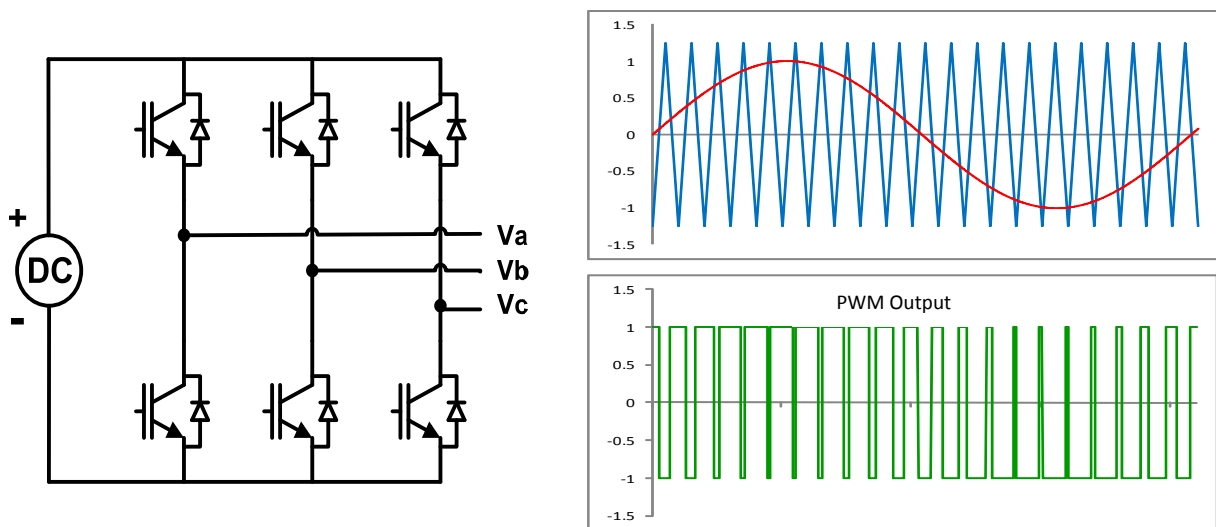

Figure 1. Three Phase Inverter PWM Generation

As shown in Figure 1, the PWM waveform is generated by comparing a reference signal (sinusoidal red trace) and a carrier waveform (triangular blue trace). The PWM waveform controls the Insulated Gate Bipolar Transistor (IGBT) switches to generate the AC output. When the reference signal is bigger than the carrier waveform, the upper IGBT is triggered on (lower IGBT being off) and positive DC voltage is applied to the inverter output phase (A). In the other case, when the reference signal is smaller than the triangular carrier waveform, the lower IGBT is turned on (upper IGBT being off) and negative DC voltage is applied to the inverter output. The reference signal magnitude and frequency determine the amplitude and the frequency of the output voltage. The frequency of the carrier waveform is called the modulation frequency. In order to generate more precise sinusoidal AC voltage waveforms and keeping the size of the LC filter small, high modulation frequencies are generally used.

There are many industrial standards that control the noise and harmonic contents in an inverter system, such as AC motor drives, Uninterrupted Power Supplies (UPS) or other AC power applications. In the case of grid-tied PV inverters, the Institute of Electrical and Electronics Engineers (IEEE) 1547, Underwriters Laboratories (UL) 1741 and FCC Part 15B standards specify the guidelines to control the harmonic contents of the output current and the Electro Magnetic Interference (EMI) generation in the inverter. The guidelines guarantee that:

- The inverters do not generate excessive noise and harmonics, which can contaminate the AC grid voltage.
- The inverters are immune to electrical and magnetic noise from other sources and provide reliable operation in an environment of high electromagnetic noise.
- The inverters do not generate unwanted radiated or conducted noise, which can disturb the stable operation of other equipment coupled either electrically or magnetically.

Most of the PV inverters manufactured in the United States are designed to meet UL 1741 and IEEE 1547 standards. As the capacity of PV generation in power distribution systems grows, utility companies become increasingly concerned that the noise and harmonics from the PV inverter systems will adversely impact the power quality or affect the operation of other equipment and cause it to malfunction or otherwise disrupt the stable operation of the power distribution system.

This article lists the possible sources of the harmonics and switching noise generated by the PV inverter and describes how they can be controlled to meet customer requirements and relevant industrial standards. To present the theoretical and experimental analysis of this phenomenon, a Solectria Renewables PVI 82kW - 480VAC PV inverter system is being used. However, since most PV inverters have similar types of component configurations, the information in this article can be used to understand the harmonics and EMI issues in a variety of inverter systems.

2. PV Inverter System Configuration

Figure 2 shows the block diagram of a Solectria PVI 82kW inverter, including the filters used for attenuating the high frequency noise on the inverter output voltages and currents. There are two main sources of high frequency noise generated by the PWM inverters. The first one is the PWM modulation frequency (2 ~ 20kHz). This component is mainly attenuated by the LC filter and the transformer. The second source originates in the switching transients of the power electronics switching devices (IGBTs). The frequency of the switching transients is dependent on the device switching characteristics, gate drive circuit and the snubber circuit in the inverter, and ranges from several hundred kHz to 100MHz. The series filter and the shunt filter are designed to attenuate the frequency components caused by these switching transients and also the harmonics from other subsystem components such as the switched mode power supply (SMPS) and other inverter control circuitry.

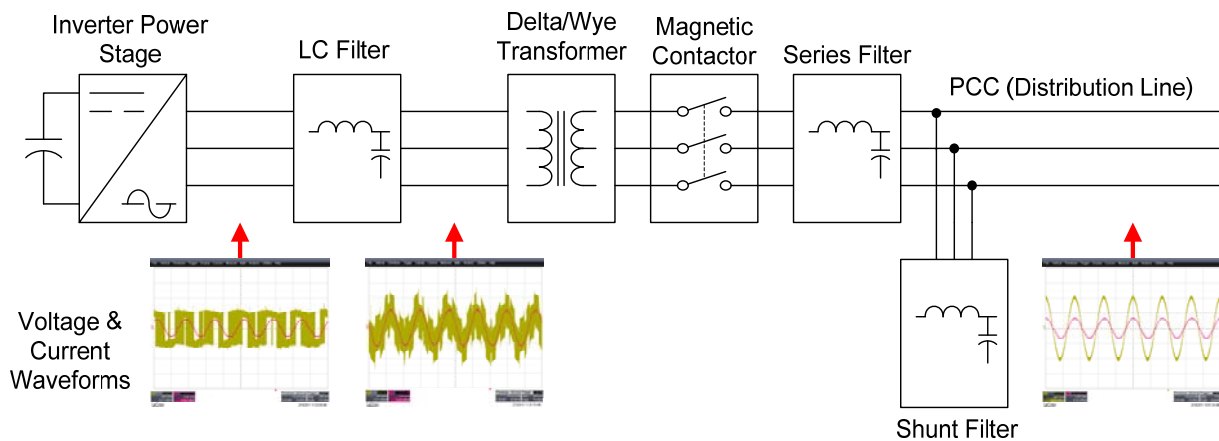

Figure 2. PVI 82kW Inverter Filtering Configuration and V/I Waveforms

Figure 2 also shows the voltage and current waveforms in each stage of the inverter. Most of the harmonic components in the voltage and current waveforms are filtered out by the LC, series and shunt filters. The inverter output current is in phase with the voltage (unity power factor) and the total harmonic distortion (THD) is less than 5% at rated operation, which is far better than the current THD of most industrial loads, and is comparable to the output current waveforms of an Uninterruptable Power Supply (UPS).

2.1. PWM frequency and LC filter

An LC filter is used to attenuate the PWM modulation frequency and its harmonics in the inverter system. The leakage inductance of the integrated isolation transformer further attenuates the high frequency component so that the output current will be sinusoidal and meet the desired THD limit. A symmetrical PWM scheme is generally preferred to reduce the ripple in the inverter output current. A symmetrical PWM scheme compared to an asymmetrical PWM reduces the effective peak-to-peak ripple current by half when using the same switching frequency.

As shown in Figure 2, the inverter’s power stage output voltage waveform is composed of a series of square waveforms and includes high frequency components. The current waveform is relatively smooth and sinusoidal as the inverter output current flows into the inductor in which it cannot change instantaneously.

Figure 3 compares the power stage output to the inverter output current. In the time domain, the waveforms do not look very different. However, the Fast Fourier Transformation (FFT) results show that the inverter current after the LC filter has much less high frequency components than the unfiltered power stage output current.

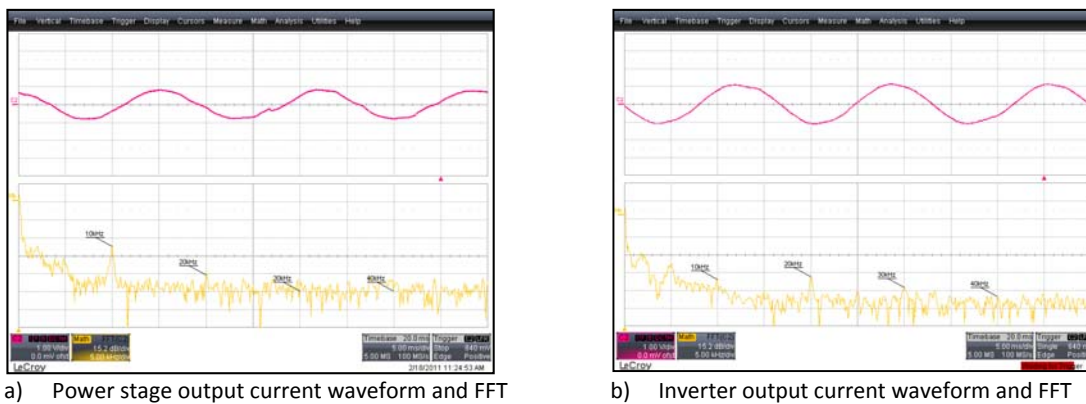
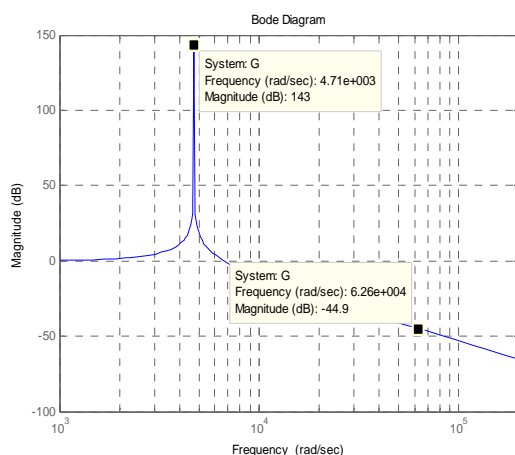

Figure 3. PVI 82kW Current Harmonic Analysis

This filtering effect can be illustrated in a Bode Plot. Figure 4 (a) shows the LC filter frequency characteristics using the theoretical frequency analysis and the measured harmonic components with a frequency analyzer when the inverter operates at full power. In the example the LC filter resonant frequency is tuned to 750Hz. Assuming a PWM modulation frequency of 10 kHz it would be attenuated to 45dB below the fundamental current component. The actual inverter output current FFT result shows that the 10 kHz ripple component is further attenuated to 60dB below the fundamental component by the shunt filter, which is about 0.1% of the fundamental 60Hz current. Figure 4 (b) shows that all the harmonic component frequencies are well controlled and the overall THD is 2.31%.



a) LC Filter Bode Plot (Theoretical Result)

THD	2.31%	12 th	0.08%
		13 th	0.16%
2 nd	0.71%	14 th	0.25%
3 rd	1.85%	15 th	0.05%
4 th	0.57%	16 th	0.05%
5 th	0.52%	17 th	0.06%
6 th	0.10%	18 th	0.04%
7 th	0.61%	19 th	0.05%
8 th	0.07%	20 th	0.04%
9 th	0.08%	21 st	0.05%
10 th	0.12%	22 nd	0.03%
11 th	0.24%	23 rd	0.07%

b) Inverter output current FFT (Test Result)

Figure 4. PVI 82kW System Output Current Harmonics Analysis

2.2. High frequency noise generated by switching transients

When the switching devices are turned on and off, high dv/dt and di/dt cause oscillations during the transients, which contain high frequency noise in the range of 100kHz or higher. Figure 5 shows the switching transients of the IGBT voltage and current with two different gate drive circuit designs.

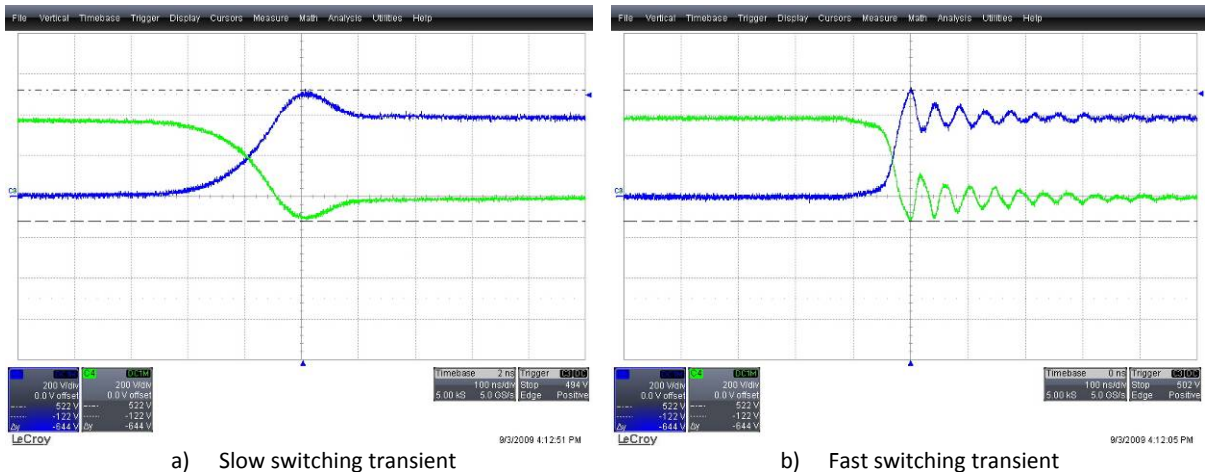

Figure 5. High Frequency Noise Generated by IGBT Switching Transients

By using a slow switching transient (a), the oscillation can be minimized but switching losses are increasing due to longer operation of IGBTs in the active region. With a faster switching speed, the switching losses can be kept lower but oscillations in voltage and current are being generated due to the parasitic inductance and capacitance in the inverter stack. This high frequency oscillation falls into the frequency band regulated by FCC. In order to increase the overall efficiency of the inverter and at the same time to minimize EMI, the IGBT switching speed and noise filter design must be carefully coordinated.

There are other sources of switching noise in the inverter system caused by the Switch Mode Power Supplies SMPS and the digital control logic circuits. The noise from these components can reduce the system performance by contaminating internal analog feedback signals, resulting in logic level or communication errors and could also cause EMI interference with the outside world.

The high frequency noise can be further classified into radiated noise and conducted noise. The radiated noise can be controlled in many ways at the board level and at the system level such as shielding, component layout, wiring routing, and signal grouping. The conducted noise can be controlled by grounding or the use of proper filters, carefully designed to eliminate specific frequency components. In Solectria's PVI 82kW inverter, excellent noise levels were achieved by implementing a robust printed circuit board (PCB) layout in combination with hardware and software filters. Noise in signal circuits is solely controlled by ferrite beads and proper grounding. The PVI 82kW inverter also features series and shunt filters in the final output stage of the system. These filters are frequency band limiting and designed to filter out switching frequency transients.

Series Filter

The IGBT switching transients normally last 0.1 ~ 10usec, therefore, the filter should be tuned to between 100kHz and several MHz. Also, the controller uses a SMPS switched at 150kHz. The series filter in the PVI 82kW attenuates both common mode and differential mode noise. It provides 80dB common mode attenuation for the frequencies between 100kHz and 1MHz, and 70dB differential mode attenuation for the frequencies between 200kHz and 3MHz. The filter is selected to eliminate the system specific dominant frequency components, and is not active in the lower PWM modulation frequency range.

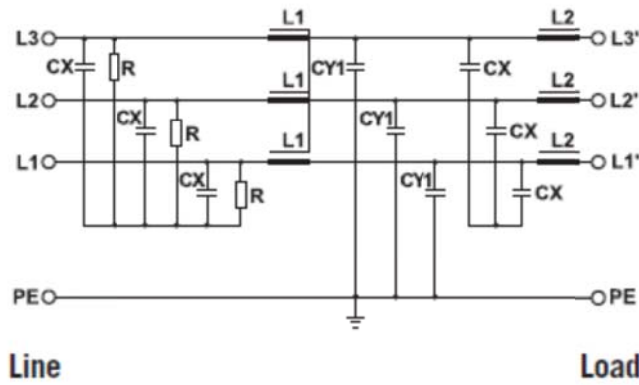

COMMON MODE ATTENUATION

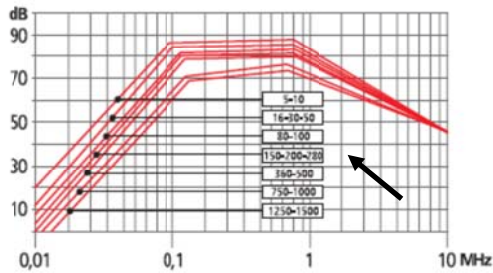

DIFFERENTIAL MODE ATTENUATION

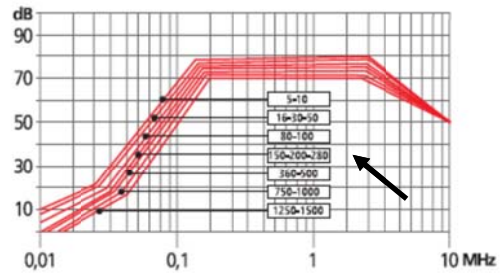
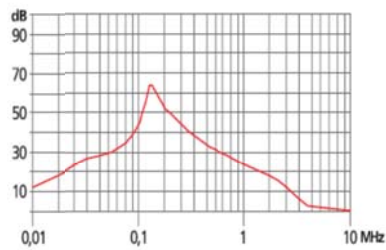

Figure 6. Series Filter Characteristics

Shunt Filter

The selected shunt filter for the PVI 82kW inverter has a resonance point around 150kHz and provides a reduction of noise interference particularly in the frequency range between 50kHz and 5MHz. This filter is added to further reduce the switching noise from the power stage as well as from the switch mode power supply in the inverter control system. The shunt filter also provides a protection circuit against surges of atmospheric origin to the grid, typically caused by lightning and characterized by high current levels of short duration. The filter reacts in a few microseconds to current spikes of a few kA, and protects the system against impulse surges of up to 1000 volts.

RESONANCE CIRCUIT RESPONSE



RESPONSE TO CURRENT PULSE

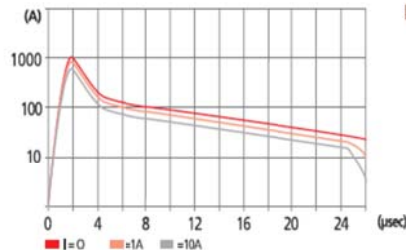

ELECTRIC DIAGRAM

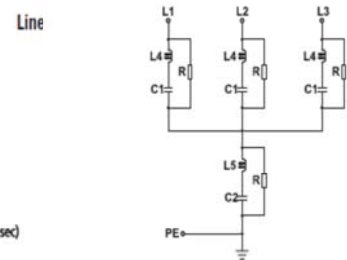

Figure 7. Shunt Filter Characteristics

3. System wide EMI Control

The following pictures show some of the EMI reduction strategies that are used in a PVI 82KW inverter.



Solid Grounding



Controlled Wire Routing



Board Level Filtering and EMI Reduction Layout



Wire Twisting

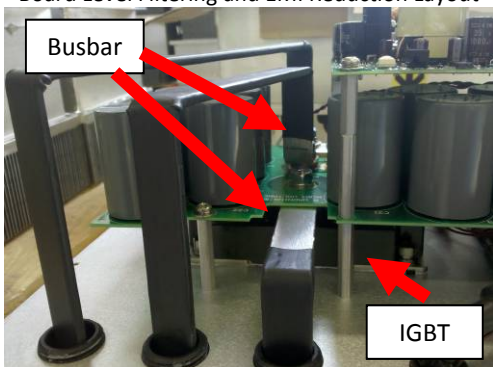

Stack Configuration for Reduced Stray Inductance

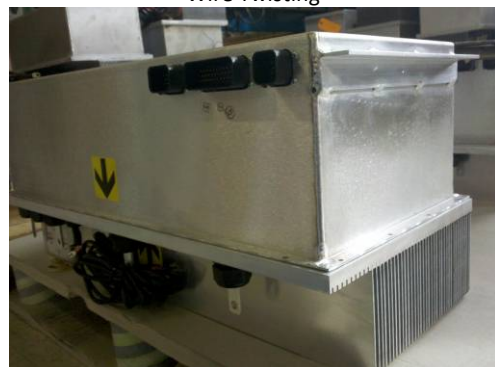

Power Electronics Enclosure for EMI Shielding

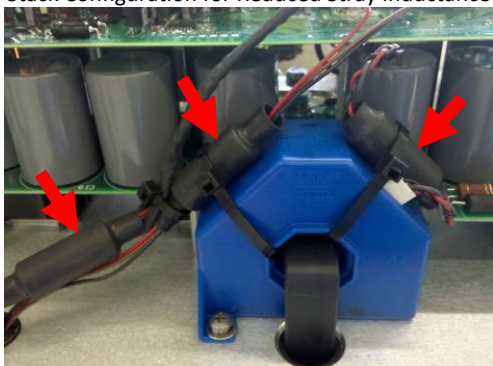

Analog Signal Conditioning using Ferrite Beads



DC side High Power Wiring for EMI shielding

4. Harmonics Generated by Firmware Control

Conventional PV inverters firmware runs at least two nested control loops. One is the AC current control loop to control the inverter output current, purely sinusoidal and in phase with the grid voltage, generating active power. The other is the DC voltage control loop in conjunction with a Maximum Power Point Tracking (MPPT) algorithm to most efficiently harvest the DC power generated by the solar panels.

When grid conditions change due to power grid transients, power line faults or load based voltage fluctuations in the distribution line, the inverter output current is controlled to balance the power transfer from the PV array to the grid. If the current control loop gains are tuned properly, the dynamic response due to the transients can be controlled at the bandwidth usually less than 1kHz. The DC voltage control loop is around the current control loop and is usually controlled at a lower sampling rate. If the DC voltage fluctuates due to sudden changes in weather conditions, the DC voltage control loop has a certain bandwidth to react and stabilize the system output. During sunlight transients, the system might generate even slower oscillations in the DC bus voltage and output AC currents control. Since the DC voltage control loop bandwidth is low, it does not cause any harmonics or EMI issues. However, if the voltage control loop were not tuned properly, the generation efficiency would decrease due to failure to track the maximum power point of the PV panels.

Solectria Renewables' inverters have been fully tested at different load conditions to have excellent dynamic characteristics for both the AC current and DC voltage control loops. The AC current control bandwidth is about 2kHz and the DC voltage control bandwidth is more than 100Hz.

5. Conclusion

This article described how the current harmonics and EMI are controlled in PV inverters. IEEE 1547, UL 1741 and FCC Part 15B standards impose strong guidelines for grid-tied PV inverters to reduce current harmonics and eliminate electromagnetic noise. Extra attention is given by the PV inverter manufacturer to design inverters that are immune to EMI problems and guarantee reliable operation of the inverter in all worst case operating conditions.

Different types of practical harmonics and noise reduction strategies for a commercial three-phase PV inverter were introduced in this article. The filtering of harmonics and EMI needs to be carefully designed to maintain the control bandwidth of the inverter and to provide clean and reliable control signals in both analog and digital electronic circuits. The PVI 82kW inverter system is equipped with several levels of harmonics and EMI filtering and its effectiveness and reliability have been proven in the harshest commercial and utility scale applications.



Controlled Workmanship



8 Hour HASS Burn-in Test and Final Verification

Reducing Noise in PV Power Plants

Comprehensive testing points the way to significantly reducing noise from central inverters



Photovoltaics in Japan: SMA Sunny Central CP JP inverters are in operation in the Kagoshima PV power plant and in densely populated areas of the island country.

Typically, PV power plants are spread out over several acres of land far from residences, towns or cities. Up until now, central inverter manufacturers have not had to deal with noise emissions from the central inverters in and near such large industrial PV farms. In collaboration with the Rheinisch-Westfälischen Technischen Hochschule Aachen (RWTH University Aachen), SMA Solar Technology AG carried out comprehensive and complex testing to identify the sources of noise and ways to reduce it. We found that because noise emissions behave logarithmically, a 10dB reduction will cut the central inverter's noise emissions by half.

"We've been asked to look into reducing the noise generated by our central inverters, especially those in the more densely populated regions in Japan," said Aaron Gerdemann, Global Product Manager at SMA Solar Technology AG and expert for the Japanese market.

As more and more major PV power plants are operating near residential areas, villages and towns, there is a growing demand for quieter central inverters. The findings of the tests have already led to implementing the first noise reduction measures, and a retrofit kit is available now for central inverters already in operation.

Test Scenario for Extensive Inspection

The experts from RWTH Aachen have extensive experience in industrial noise emission testing for machines and machine systems. However, this project was the very first time that inverters had been the focus of noise emission tests. Using extensive test equipment, the team performed a multitude of different acoustic tests to identify and classify all sources of noise in the central inverter during operation.

They performed a number of assessments and analyses including:

- Investigation of structure-borne noise transfer paths
- Transfer of airborne noise and its effects
- Analysis of noise caused by vibrations
- Resonance frequency testing

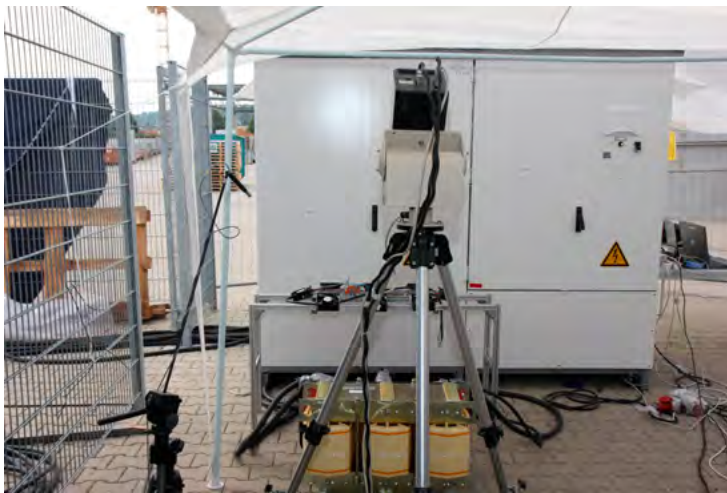

To visualize from exactly which sources noise is generated, an acoustic camera was used to closely examine a stock Sunny Central 500 CP-JP central inverter during normal operation up to full load.

Once the test team was able to identify the choke as the main source of noise, it was removed and went through the same testing.

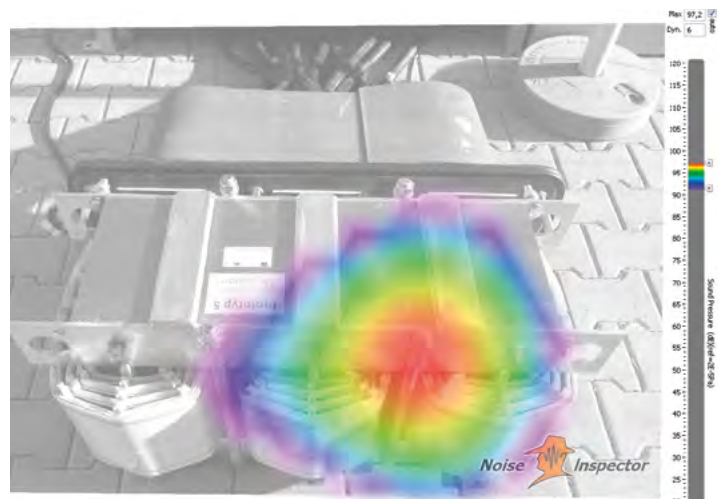

Measuring Airborne and Structure-Borne Noise



They intentionally produced structure-borne vibrations inside the central inverter with a shaker unit in place of the choke, and closely observed how individual components reacted.

Using an omnidirectional loudspeaker inside the central inverter, the test team was able to identify where structure noise and airborne noise occurred.



Considerable Reduction in Noise

Taking into account all the test results, the Sunny Central CP central inverter can now be operated with considerably reduced noise emissions. The actual noise of the central inverter depends on different parameters and varies individually in for example power class, installation (concrete base or plinth) optional equipment, and component tolerances.

The Sunny Central CP inverters underwent extensive hardware and software modifications to reduce noise. For example, the inverter's modulation process has been changed and the air exhaust equipped with a specially designed splitter silencer. The internal structure of the splitter silencer was configured specifically for wave lengths resulting from the inverter bridge's 3 kHz cycle frequency. Also, other inverter components have been acoustically improved by adding base paneling and an air baffle. On average these measures lead to a reduction to half of the perceived noise level in a 10 meters distance.

These noise reducing measures are available for central inverters as an option but can also be used to retrofit existing installations. Long term, plans are underway to find a choke manufacturer to produce a "quieter" choke.



Splitter silencers with rain protection attached on the rear of the central inverter.

SMA Solar Technology AG
Sonnenallee 1
34266 Niestetal, Germany
Tel: +49 561 9522-0
Fax: +49 561 9522-100
E-mail: Powerplants@SMA.de
www.SMA.de/powerplants

Is large-scale energy storage dead?

Footnote 3

Is large-scale energy storage dead?

Posted on [April 8, 2016](#) by [Roger Andrews](#)



Many countries have committed to filling large percentages of their future electricity demand with intermittent renewable energy, and to do so they will need long-term energy storage in the terawatt-hours range. But the modules they are now installing store only megawatt-hours of energy. Why are they doing this? This post concludes that they are either conveniently ignoring the long-term energy storage problem or are unaware of its magnitude and the near-impossibility of solving it.

The graphic below compares some recent *Energy Matters* estimates of the storage capacity needed to convert intermittent wind and solar generation into usable dispatchable generation over different lengths of time in different places. The details of the scenarios aren't important; the key point is the enormous differences between the red bars, which show estimated future storage requirements, and the blue bars, which show existing global storage capacity (data from [Wikipedia](#)). It's probably not

an exaggeration to say that the amount of energy storage capacity needed to support a 100% renewable world exceeds installed energy storage capacity by a factor of many thousands. Another way of looking at it is that installed world battery + CAES + flywheel + thermal + other storage capacity amounts to only about 12 GWh, enough to fill global electricity demand for all of fifteen seconds. Total global storage capacity with pumped hydro added works out to only about 500 GWh, enough to fill global electricity demand for all of ten minutes.

Yet microscopic additions to installed capacity are apparently considered a cause for rejoicing. [Greentechmedia](#) recently waxed lyrical about the progress made by energy storage projects in 2015. "Last year will likely be remembered as the year that energy storage got serious projects of all sizes were installed in record numbers" But when it goes on to list "the Biggest Energy Storage Projects Built Around the World in the Last Year" we find they're all 98-pound weaklings:

Also notice that while megawatts are specified MWh usually aren't. There are two possible explanations for this. First the facilities aren't designed to store energy. They are primarily for frequency control, load following etc. The *MW* are important but the *h* aren't, or at least not very. Second, the policymakers who mandate these facilities don't see any difference between a MW and a MWh.

And I say "mandate" because that is what the state of California recently did. California recognized that it would have to solve some grid stability problems before it could expect to meet its 50% renewable energy by 2030 target, so in 2013 it passed a "[Huge Grid Energy Storage Mandate](#)" that required the state's big three investor-owned utilities to add 1.3 gigawatts of energy storage to their grids by 2020. Three points are worthy of note here:

- Relative to California's 50GW peak load 1.3GW can hardly be described as "huge".
- The mandate again doesn't say how long the storage should last, i.e. how many gigawatt-hours are needed.
- The proposal specifically excludes pumped hydro storage projects of 50 megawatts or more.

And [the rationale](#) for excluding pumped storage projects over 50 MW deserves a paragraph all to itself:

The California Public Utility Commission concluded that although large-scale pumped storage hydro meets the statute's definition of an energy storage system, it must limit the size of eligible pumped storage systems in order to encourage the development and deployment of a broad range of energy storage technologies. In the CPUC's view, the goal of creating a new market for a range of storage technologies would be

undermined if the IOUs could meet their targets by acquiring a pumped storage facility: The majority of pumped storage projects are 500 MW and over, which means a single project could be used to reach each target within a utility territory.

What is this broad range of storage technologies that pumped hydro threatens to undermine? Based on proposals received to date they include bi-directional EV charging stations, molten sulfur batteries, zinc hybrid cathode batteries, lithium-ion batteries, thermal energy stored in ice, in used EV batteries and in rechargeable electrolytes. In short, California will consider any type of energy storage system provided it isn't pumped hydro, the only large-scale energy storage technology that can be guaranteed to work.

Which brings up the question of which of the technologies don't work. In the recent ARES post Greg Kaan made the following comment:

This thread is turning into complete nonsense, not due to the commentators here (*thanks Greg*) but simply through the "solutions" being presented to try and cope with intermittent power production.

And Greg is quite correct. The solutions being presented to cope with intermittent power production range from green dreaming to downright bonkers. Here's a selection, courtesy of Wikipedia:

- Compressed air
- Liquid air
- Batteries
- Electric vehicles
- Flywheels
- Underground hydrogen storage
- Power to gas
- Hydro and pumped hydro
- Superconducting magnets
- Thermal storage.

To which I will add:

ARES rail storage, which we recently looked at.

The 500m-diameter underground granite cylinder that moves up and down without ever cracking, leaking or getting stuck

Flat Land Energy Storage, which was reviewed [here](#).

Anyone who can see a way of commercializing any of the unproven technologies on the list is encouraged to provide details. (Although two of them are in fact capable of providing meaningful amounts of storage. The first is power-to-gas, which was dismissed [here](#) as being far too complicated, inefficient and uneconomic. The second is very-large-scale pumped hydro, which was discussed [here](#). The project delivered 6.8TW of storage but involved turning a large chunk of the Scottish Highlands into an inland sea.

So here we have an impossible situation, with green pipe-dreamers and utilities whom one suspects should know better trying to solve an unsolvable problem with technologies that have no chance of solving it. So what happens next? Well, at some point something obviously has to give, but what, where and when is the question.

— by Damian Waco in CivicSolar (2012)

Footnote 4

Electrical interference is a problem that might be encountered with solar power system electronics. Noise emissions from inverters are generally reduced by a combination of shielding, noise cancellation, filtering, and noise suppression.

Electrical interference is a problem that might be encountered with solar power system electronics. Any digital electronic equipment produces at least some noise and nearly all equipment now used in PV systems is digital. The most common problems arise from charge controllers and many inverters (particularly modified sine wave inverters). Nearly all charge controllers send power to batteries in the form of pulses and high power digital pulses are one of the worst interference sources.

Electrical interference can be in the form of radio waves emitted from a device (termed RFI – radio-frequency interference) or can be non-radiated, such as line noise coming in from power or control lines (termed EMI – electromagnetic interference). Nearly all consumer appliances and electronic equipment sold today must comply with FCC part B - which regulates the maximum amount of EMI that devices can radiate. But nearly all DC and solar equipment is exempt from Part B, which means that they can put out much more EMI and still be legal. In the case of grid-tied PV inverters, the IEEE 1547, UL 1741 and FCC Part 15B standards specify the guidelines to control the harmonic contents of the output current and EMI generation in the inverter. These guidelines guarantee that inverters do not generate excessive noise and harmonics, which can contaminate the AC grid voltage.

Inverters can be classified by their output waveform as square wave inverters (basic and least efficient), modified sine wave (an approximation to sine wave output), and true sine wave. Any deviation from a true sine wave means that high-frequency harmonics are being generated and can either be radiated or conducted into the environment. A simple square wave inverter simply switches between positive and negative outputs each half cycle. Such inverters often have difficulty starting motors, are least efficient and produce a lot of distortion that can sometime be heard as a buzzing sound. Sine wave inverters are the most expensive inverters but produce the purest AC current that matches the current in the grid, have the highest efficiency and the least distortion. Modified sine wave inverters are in between and are used in PV systems that do not operate sensitive equipment. Modified square wave inverters are appropriate for operating a wide variety of loads, including motors, lights and standard electronic equipment like TVs and stereos. Motors, such as refrigerator motor, pumps, and fans will use more power from the inverter due to lower efficiency, some fluorescent lights will not operate quite as bright, and some may buzz or make annoying humming noises. Appliances with electronic timers and/or digital clocks will often not operate correctly.

Noise emissions from inverters are generally reduced by a combination of shielding, noise cancellation, filtering, and noise suppression. Metal enclosures are common for inverters and some other equipment. The use of shielded, twisted pairs for wiring is a common and effective practice. Filtering

is a common feature of nearly all electronics. The most common method is to use capacitors across a signal line or wire to ground to get rid of the noise. More recently, the use of noise suppression provided by ferrite chokes, cores, and beads has become more commonplace in PV installations. With appropriate equipment choices, noise reduction techniques and proper installation practices, noise emissions from PV installations are not a significant problem.

What about actual sound from the inverter?

The electronic noise of an inverter can also have an audible component. Most electronic noise cannot be heard, but in larger commercial inverters and some residential grid tied or off grid models, it's a good idea to review the decibel rating of the inverter before selecting the installation location.

Sample Noise Emission Values of a three phase commercial solar inverter

This table is from the NOISE REPORT ODOT Solar Highway Project: West Linn Site Clackamas County, it shows the dBA noise level of commercial inverters at the Clackamas solar project. Understanding the dBA noise from a commercial inverter is an important component in siting an inverter at solar project.

Location of Source (number of inverters)	Noise Level at 50 Feet	Receiver Location	Distance from Source to Receiver	Noise Level from Inverters at Receiver
	dBA			(feet)
I10 (3)	64	RM6	800	40
IM5 (3)	64		360	47
IM7 (4)	65		2040	33
I10 (3)	64	RM8	1280	36
IM5 (3)	64		1800	33
IM7 (4)	65		216	52
I10 (3)	64	R11	224	51
IM5 (3)	64		544	43
IM7 (4)	65		1336	36

Note: Locations of inverter pads can be see on Figure 3.

Noise Emission Value of Solar Inverter

Footnote 5

Why Wellfleet will get Wind Turbine Syndrome (Massachusetts)



windturbinesyndrome.com/2010/why-wellfleet-will-get-wind-turbine-syndrome/

Editor's note: The following article was published on this site in March 2010, when the Town of Wellfleet, Mass., was careening toward installing a huge wind turbine on the edge of town.

Happily, the Town Selectmen stopped the project dead in its tracks when they learned of the health hazards and other manifold shortcomings of this screwball plan. We are reposting the article because, alas, it somehow got misplaced when we created our new website. It now appears on the present website, again, for the first time. We are reprinting it, as well, because we get many questions from communities and individuals facing the prospect of one, two, or three turbines, wondering if one or two turbines pose a problem to health. The answer is, "yes"!

—Calvin Luther Martin, PhD (3/15/10, reprinted 11/7/10)

Wellfleet, Massachusetts. Nice town out on Cape Cod. Ever been there?

Me neither. But it's gotta be nice. National Seashore. Outstanding bird-watching. (Big migratory corridor; zillions of shorebirds come through.) Plus there's marshes and ponds. And loads of really interesting people. What's not to like?

▫ Coming soon is one colossal wind turbine. Then it won't be so nice. At least for people living within 2 km (1.25 miles) of that thing's acoustic shadow.

The plan is for a Vestas V90 1.8/2.0 MW.

Photo from Vestas website, with human figure added for perspective

What's not to like? "Clean, green, renewable," after all. Right?

I'll try to be brief and keep it simple. (This isn't going to be a happy story. If you don't like sad stories, better bail out now.)

Wellfleet hired an engineering firm (Tech Environmental) to predict how much noise this thing will make. (The report refers to it antiseptically as the Project. It's not the *Project*; it's a stupendously big goddam wind turbine with 3 propellers churning an area the size of a football field at approx. 200 mph at the blade tips, and 200 gallons of lubricating oil in the nacelle—bus-sized box at the top—waiting to start leaking. Plus access roads, immense steel rebar-reinforced concrete base, and underground or above-ground powerlines—and the possibility

of “stray voltage,” depending on whether the underground lines are properly insulated, which often they are not, and depending on how surplus power is disposed of when the grid can’t handle it. Let’s start this story by getting the language right.)

Here’s the full report. Be prepared to doze off, which may well be its intent. [“Acoustic Study of the Community Wind Project for One V90 Turbine, Wellfleet, MA.”](#)

Peter H. Guldberg, Founder & President,
Tech Environmental

Download it. Look at p. 2, paragraph 1. Notice the sentences highlighted (by me) in italics.

“The frequency spectrum of predicted maximum sound levels at the nearest residences was analyzed for low-frequency sound. *In the two lowest octave bands (31.5 Hz and 16 Hz), the project’s sound levels will be below the threshold of human hearing. This means very low-frequency sound from the wind turbine will not be audible at the nearest residences or at White Crest Beach and there will be no perceptible infrasound. The project will not cause vibration effects inside residences.*”

Now p. 19, bottom paragraph. Notice the sentence highlighted (by the author, presumably Peter Guldberg—the guy in the suit) in italics.

“The frequency graphs (Figures 4 through 11) reveal that in the two lowest octave bands (31.5 Hz and 16 Hz) the project’s sound levels will be below the threshold of human hearing. *This means very low-frequency sound from the wind turbine will not be audible at the nearest residences or at White Crest Beach.*”

Okay, turn to Fig. 4. I copied it, below, and added a few overlays. First, note Guldberg’s explanatory legend in the upper right corner. It says the broken red line shows the “Threshold of Human Hearing.” So far, so good.

Take a look at the path of that broken red line. On the left side of the graph it shows that at very low frequency (20 Hertz and below), *whatever noise & vibration this thing makes will be well below human hearing.* (This claim, by the way, is probably true.)

Notice where the broken red line crosses the heavy blue line—somewhere less than 45 dB. (That heavy blue line shows “V90 Maximum Continuous Sound,” according to the legend.) In other words, as the noise & vibration of the V90 continues to climb, Wellfleeters have nothing to worry about, because humans can’t hear it. “*This means very low-frequency sound from the wind turbine will not be audible at the nearest residences or at White Crest Beach*” (p. 19).

Do you smoke? Mind if we go outside? (Can I bum one?)

Nice evening. Um, all the stuff on the graph? Like I said, it’s correct. *But irrelevant.*

Take another look at Guldberg's graph, above. See where I've doctored it a bit on the left side. I did what the guy in the suit should have done: I extended the frequency (Hertz = Hz) down to zero. I then highlighted the Sound Pressure Level (which is in decibels = dB) for 0-20 Hz with a wide blue band.

Still with me? Focus on the wide blue band I drew in.

(Mind if I bum another smoke?) Notice that any turbine noise/vibration within that wide blue band is well below the threshold of human hearing.

Here we need to get into a little physiology. (Don't panic; it's painless.) So what's "human hearing" mean? Human hearing is what the *cochlea* detects. The cochlea's the snailshell-shaped organ in this diagram.

When Guldberg writes,

The frequency graphs (Figures 4 through 11) reveal that in the two lowest octave bands (31.5 Hz and 16 Hz) the project's sound levels will be below the threshold of human hearing. *This means very low-frequency sound from the wind turbine will not be audible at the nearest residences . . .*

. . . he means *the cochlea (which is the organ we hear with) won't detect it.*

He's right, as I said above. (There are some minor quibbles one could interject here, but for all practical purposes he's right.) The broken red line in Fig. 4 corresponds to what the cochlea is detecting and, to flog the issue once more, the cochlea won't hear that low-frequency noise and infrasound.

While we were smokin' the first cigarette, I sand-bagged you by saying that what the cochlea "hears" is irrelevant. Guldberg is focusing on the wrong organ. *It's not the cochlea that matters; it's the little organs immediately adjacent to it that matter.* Three weird little organs you vaguely remember from high school biology.

They're called the (1) semi-circular canals, (2) utricle, and (3) saccule. All together, as a triad, they're known as the "vestibular organs."

Better take a deep drag on that cigarette, 'cause these cute little organs are gonna determine whether you live in heaven or hell in the months ahead. (Click [here](#) and [here](#) and [here](#) for hell on earth. Then re-read the "Inferno." Living 2 km from a turbine is to live in one of Dante's circles of hell—precisely 2 km from ground zero.)

The utricle and saccule, arguably the most interesting of the vestibular organs, are known as the otolith organs. Because they have "otoliths" in them. What's an otolith? (If you'd paid more attention in biology, instead of gazing at the pretty girl in row 1 . . .) It's an "ear stone." Yeah, that's what it means. "Ear rocks." Except they're minute. Made out of calcium carbonate. Yeah, same stuff as seashells and chalk.

Wellfleeters have seashells in their heads. In fact, we all do. In fact, all vertebrates do. Everything that climbed aboard Noah's Ark, and a lot that didn't—they've all got them. This means they're *Very Important Structures* (VIS) in Mother Earth's great big complicated scheme of things.

In these seashell organs—the otolith organs (utricle & saccule)—lies the key to much of your brain function, dear Wellfleeter—some otolaryngologists think they're the Sixth Sense—and the explanation for why many of you are surely going to get Wind Turbine Syndrome when the town throws the switch on that V90.

Stop here. If you live within 2 km of that proposed V90, you absolutely must read this long passage taken from Pierpont's "Wind Turbine Syndrome" book ("Report for Non-Clinicians," pp. 200-204). If you're a Wellfleeter living outside that 2 km strike zone, skip this section. If you're not a Wellfleeter at all, you too can skip this section—until you, too, find yourself targeted by a wind turbine (or natural gas compressor) 2 km or less from your back door.

The otolith organs are key to understanding Wind Turbine Syndrome. They consist of two little membranous sacs, the utricle ("you-trick-ul") and saccule ("sack-ule"), which are attached to the cochlea ("coke-lee-ah," the spiral-shaped, membranous organ that transduces the mechanical energy of sound into neural signals) and to the semicircular canals (membranous organs which make a semi-circle in each of the three planes of movement—vertical forward, vertical sideways, and horizontal—and transduce angular acceleration: when your head is nodding or turning, they detect it).

Embedded in the two otolith organs are—believe it or not—rocks. (*Oto* = ear and *lith* = rock. Remember when your teacher declared you must have rocks in your head?) Well, not really rocks. They're tiny. In fact they're microscopic crystals of calcium carbonate (like calcite or oyster shells), called otoconia ("oto-cone-ia"), stuck together in a mass on top of the patch (macula, pronounced "mack-you-la") of movement-sensing hair cells. The weight and mass of these stones allows the hair cells to detect gravity and linear acceleration.

Things now get truly beautiful. Imagine God "with his broad sculptor-hands leaf[ing] through the pages in the dark book of the beginning" (Rilke), showing us the blueprints for the semicircular canals and otolith organs. Structures so fundamental to brain function that they are shared by fish, amphibians, and (so-called) higher vertebrates. Yes, including us. In each of these creatures these organs perform a function not only older than the mind can grasp, but so profound it has come to define what mind itself is. (Note: the cochlea, the organ we use for hearing, evolved much later in mammals.)

We are in the presence of a master key to the mammalian mind. (Not just mammalian, but the entire backboned animal world.) It is this master key, dear reader, that is counterfeited by the low frequency noise from the massive, spinning wind turbine outside your window.

We're in the presence, here, of truly ancient anatomical structures. Many millions of years old. Fish, amphibians, and "higher" vertebrates all have semicircular canals and otolith organs.

Consider this. Teleost fish, such as cod, hear with their otolith organs. Their otolith organs are their detectors of sound and vibration, such as the movements of nearby predators or prey. Their otolith organs also detect gravity (which way is up) and acceleration (if the fish moves or turns). Atlantic cod otolith organs are so sensitive to water perturbations from infrasound (at 0.1 Hz, or one wave every 10 seconds) that the fish may be able to use seismic sounds from the Mid-Atlantic Ridge or the sounds of waves breaking on distant shores to guide them during migration, hundreds of miles away.

Consider this. In frogs, the saccule (one of the otolith organs) remains the part of the ear most sensitive to substrate-borne vibration. Both the saccule and a newly evolved part of the frog ear, the basilar papilla, detect both sound and vibration, with the saccule capturing lower frequencies and the papilla higher frequencies.

All by way of laying the groundwork for the idea that our own otolith organs have been, ancestrally, detectors of sound, vibration, and low frequency sound, in addition to detecting gravity and body movements. Human otolith organs have retained some of these functions, it turns out: they respond to noise or vibration by sending out vestibular signals.

If stimulated by a loud click or abrupt tone, normal human vestibular organs trigger a measurable, specialized reflex: an electrical signal to muscles in the front of the neck (called the "vestibular evoked myogenic potential" or VEMP). Let me rephrase this, since it's important: a noise, delivered to the ear without any movement of the head or body, sets off a rapid (neural) chain of events that changes neck muscle tone. This neck muscle signal is part of the vestibulo-collic reflex (*collic* meaning "neck," like *collar*). The purpose of the vestibulo-collic reflex is to stabilize the head during body or head movement. *A noise, albeit a loud and distinctive type of noise, sets off a reflex chain of events showing that the vestibular system thinks the body or head is moving, even when it is not. Yes, in normal, healthy adult humans.* (Wind developers, are you reading this?)

Noise doesn't necessarily come in via the air, eardrum, and middle ear, however. Vibrations or "bone-conducted sound" can reach the inner ear directly through the bone in which the inner ear is sculpted. To do this in experiments or as a clinical test, a vibrating object is put against the skin over the mastoid bone behind the ear. It takes less energy (a lower decibel level) to trigger the vestibular response when the signal comes in through bone conduction than when it comes in through the air-middle ear route. Bone conduction also works better at lower sound or vibration frequencies.

Most exciting, *it was shown in 2008 that the normal human vestibular system has a fish- or frog-like sensitivity to low frequency vibration.* In this experiment, a vibrating rod was applied to the skin over the mastoid bone, using carefully calibrated force. Subjects could hear the vibrations as tones, and the researchers detected vestibular responses by measuring electrical signals coming from the subjects' eye muscles. Interesting that this response has a distinct tuning peak at 100 Hz, meaning there is a much bigger vestibular and eye muscle response at 100 Hz than at higher or

lower frequencies. (By way of comparison, 100 Hz is equivalent to G-G#, 1½ octaves below middle C. That is, keys 23– 24 on a piano.) *At this tuning peak the vibration still produced a measurable vestibular response (eye muscle electrical signals) when the vibration intensity had been reduced so much that the subjects could no longer hear the tones. In fact, the power of the vibration that produced a vestibular response was only about 3% of the power the subjects could hear (15 dB lower).*

This means that some part of the vestibular organs in the inner ear is more sensitive to vibration or bone-conducted sound than the cochlea is. The authors of this study think it's the utricle, one of the two otolith organs, and some special, vibration-sensitive hair cells and nerve fibers that occur mixed in with the other hair cells in the utricle and other vestibular organs.

This is amazing. (It would be heretical if it hadn't been shown in a well-conducted experiment.) It has been gospel among acousticians for the past 70 years that if a person can't hear a sound, it's too weak for it to be detected or registered by any other part of the body. We can now write this as follows: If a person can't hear a sound, it's too weak for it to be detected or registered by any other part of the body. Because it turns out it's wrong. (It also means that using the A-weighted network for community noise studies is probably outdated.)

And silent be,
That through the channels of the ear
May wander like a river
The swaying sound of the sea.

—W. H. Auden, from “Look, Stranger”

Okay so far? I'm going to talk, now, as though you skipped that long passage from Pierpont. (A pity if you did; it's outstanding.) For years, Big Wind has denied that turbines produce infrasound & low frequency noise (ILFN). Either denied it exists or dismissed its significance as so trivial, it's not worth considering. The (lucrative) rule of thumb being, “If you can't hear it, it can't hurt you.”

This has been definitively proved wrong. Wrong on two counts.

□(1) It turns out the vestibular organs of the inner ear, along with other bodily organs of *balance, motion, and position* sense, are profoundly affected (“dis-regulated”) by sub-audible ILFN. It turns out that the frequency range of the normal human vestibular system (semi-circular canals, utricle, and saccule) is 0 (DC) to 20 Hz. Yes, this is infrasound, ladies and gentlemen. (Yes, DC means “direct current.”)

(2) Secondly, it turns out that industrial wind turbines produce strong infrasound and low frequency noise, precisely in the range (0 to 20 Hz) “listened to” by the vestibular organs—the body's principal organs of *balance, motion, and position* sense. There are, now, numerous noise/vibration studies unequivocally demonstrating turbine ILFN. This being one of the best:

“The Inaudible Noise of Wind Turbines,” by Lars Ceranna, Gernot Hartmann, and Manfred Henger. Presented at the Infrasound Workshop, November 28 – December 02, 2005, Tahiti. Federal Institute for Geosciences and Natural Resources (BGR), Section B3.11. Stilleweg 2, 30655 Hannover, Germany. [Click here for the full report](#) (PDF).

Graph taken from [Ceranna et al., “The Inaudible Noise of Wind Turbines” 2005, p. 14](#) with overlaid explanatory text by KS.com

The graph demonstrates unambiguous and powerful wind turbine infrasound. Infrasound (which, mind you, is lower than low frequency noise) is defined as noise & vibration less than 20 Hz—except this is “noise” you can’t hear. The point is, your vestibular organs register this as alarming, confusing signals. Signals that disrupt (hijack) these multimillion-year-old, exquisitely sensitive inner ear structures. Thus creating the panic (“fight or flight”) response upon awakening in the night, plus the vertigo and nausea, plus the more long-term memory and concentration deficits (yes, the vestibular organs affect cognition). And so on.

Think of it this way. *Wind turbines make people seasick—yet worse, because it’s long-term.* “Worse,” too, in the sense that people become sensitized to the ILFN. No, I didn’t say “desensitized”; I said “sensitized.” Meaning, you become *increasingly sensitive* to ILFN the longer the exposure. (Yes, there is plenty of clinical evidence for this. Read Pierpont’s book.)

Internationally acclaimed noise expert George Kamperman calls *Ceranna et al.* “the best documentation I have seen on wind turbine infrasound. This is a careful study on a single wind turbine utilizing instrumentation appropriate for measuring very low frequency infrasound.”

George Kamperman, P.E., INCE Bd. Cert., past member of the acoustics firm *Bolt, Beranek & Newman* (USA), currently CEO of *Kamperman Associates*

Turn to the final page of *Ceranna et al.*, p. 23, for the authors’ conclusions: “Wind turbines and wind farms generate strong infrasonic noise which is characterized by their blade passing harmonics (monochromatic signals).”

Mind if I bum another cigarette? Guldberg’s report for the Town of Wellfleet? It’s irrelevant because it focuses on the wrong organ. It’s referring to the cochlea. The whole report is built on a theory dreamed up a century ago by some acoustics professor (George Kamperman can tell you who it was) and, alas, it’s been gospel ever since. That theory being, “If you can’t hear it, it can’t hurt you.” As Pierpont demonstrates, that theory is now more properly rendered, “If you can’t hear it, it can’t hurt you.” One of the many “science” dogmas consigned to the scrapheap of history—except it’s there, hidden in plain view, serving as the linchpin of Guldberg’s report to the good people of Wellfleet.

“The frequency spectrum of predicted maximum sound levels at the nearest residences was analyzed for low-frequency sound. *In the two lowest octave bands (31.5 Hz and 16 Hz), the project’s sound levels will be below the threshold of human hearing. This means very low-frequency sound from the wind turbine will not be audible at the nearest residences or at White Crest Beach and there will be no perceptible infrasound. The project will not cause vibration effects inside residences,*” p. 2.

“The frequency graphs (Figures 4 through 11) reveal that in the two lowest octave bands (31.5 Hz and 16 Hz) the project’s sound levels will be below the threshold of human hearing. *This means very low-frequency sound from the wind turbine will not be audible at the nearest residences or at White Crest Beach,*” p. 19.

Wellfleeters might have seashells in their heads, but they don’t have garbage in their heads. This, ladies and gentlemen, is nonsense—literally, irrelevant noise.

(Note to Wellfleeters: Beware of noise engineers and acousticians making clinical pronouncements, explicit or implied. Like, “if you can’t hear it, it can’t hurt you.” These people are not clinicians. They have no clinical training whatsoever.)

But don’t believe me. Go ahead and allow your town board to build that V90 and flip the switch at a big town celebration. Balloons, hot dogs, rousing speeches, kids running around—the whole nine yards. “Let’s have a big hand for the big marvels of Big Wind!”

Then pull out this article when you’re waking up in the night in a panic and can’t get back to sleep. Or you start feeling the nausea. And vertigo. And tinnitus (ringing in the ears). And headaches. And pressure in the head and ears.

And, my favorite, a weird sensation of internal quivering, like your insides are vibrating (which they in fact are). It’s called *Visceral Vibratory Vestibular Disturbance* (VVVD). Pierpont named it that. (She will likely be reading a paper on VVVD at a clinical conference soon. She’s been invited. Wellfleeters can provide her with more data. She’d like that.) Lots of WTS victims get VVVD. The person who described it best was a medical doctor in Pennsylvania suffering from turbines next door (closest one being 2400 feet, a little under half a mile). Here’s how Pierpont defines it in her book:

Visceral Vibratory Vestibular Disturbance (VVVD): a sensation of internal quivering, vibration, or pulsation accompanied by agitation, anxiety, alarm, irritability, rapid heartbeat, nausea, and sleep disturbance. See pp. 55–60, 76–79, 224, and 235–36.

No, I’m not done listing your symptoms. There’s also cognitive problems. Your memory starts eroding. And concentration, too. Yes, that’s vestibular as well, as Pierpont explains.

Some of you will perhaps get ocular strokes, or something similar. That’s in her book, too.

Anyhow, when these strange symptoms start showing up (Wind Turbine Syndrome), pull out this article. Join the dots—to that V90.

One thing you needn't bother doing: complaining to the town board. The board will contact a noise engineer who will come out and take noise/vibration measurements. I assure you—better yet, I guarantee you—the measurements will show the turbine is compliant with town law, which will say something along the lines, “the turbine shall not exceed 50 dBA.”

Here's the key to understanding the “weighting game.” Noise engineers who come out and take measurements do so in the *audible range of hearing*. That's what the “A” refers to in the “50 dBA.” I repeat, *their measurements will unequivocally show that the turbine is compliant with your town law: it does not exceed 50 dB in the audible range.*

Whereupon the Wellfleet Town Administrator, undoubtedly a decent and honest man, will say, “Sorry folks! It's within the noise limits set out in the ordinance.”

The problem being, of course, that the noise engineer won't be measuring in the 0-20 Hz (infrasound) range, where the dB is HUGE, with frequent (several times a second) pressure bursts up to 90 dB. (Turbines, again, produce an enormous amount of infrasound.)

If, by some miracle of God, you manage to browbeat the town administrator into hiring a noise engineer to take (warning: they're very expensive) *linear* noise measurements (i.e., not limited to the A = audible range—called A-weighting), you will find, *Aha! that damn turbine is generating loads of infrasound after all!*

Not so fast! You're not out of the woods yet, because the *First Law of Noise Engineers* is still, “if you can't hear it, it can't hurt you.” No kidding. And when you get mad as hell and bellow, “*Goddammit, I'm getting sick from that turbine, and yes I can hear it!*”—you will be told it's all psychosomatic. (This is what the much ballyhooed AWEA and CanWEA “expert” report, rebutting Pierpont's “Wind Turbine Syndrome,” concludes. No kidding. It's that corny.)

It's called the “nocebo” effect. Look it up in Wikipedia. You're a nut case. You need to see a shrink. (The media will go along with it, by the way. They'll write that you “claim” to have health effects. Not that you *have* them; you *claim* to have them. And they'll call them your health “concerns,” by the way. You're not sick; you have *health concerns*. Don't look for any help from the media; most of them are stenographers for Big Wind.)

Nothing violates the *First Law of Noise Engineers*. It's like gravity. Like Jehovah, it is the great industrial “I am.” It's gotta be the Industrial Supreme Being, otherwise the whole industrial noise reign of terror which has been around since, Jeez, the first steam engine!—will start to collapse.

Then what do you do? I dunno. Punch a hole in the wall, I guess.

Back to Wellfleet. Whoever is promoting this project—that is, whoever is selling your town board on this V90—has managed to hornswoggle the board into believing the 0-20 Hz infrasound is irrelevant. *On the contrary, it's the most relevant thing about the whole project!* And, by the way, when Geof Karlson, Chair of the Wellfleet Energy Committee, states the following, he's wrong.

What is most important is the attenuation of sound over the distance from the turbine nacelle to the closest residence, almost 1/2 mile away. By the time the sound reaches the closest residences, it has attenuated to an extremely low level and its contribution to the decibel level at those residences is minor. ([Wellfleet Forum—Wellfleet Wind Turbine Program—3/1/10, p. 12](#))

Infrasound does not attenuate like this, Mr. Karlson. (Did these guys ever study physics? Or does wishful thinking and bombast trump Physics 101?) Nor does wind turbine audible noise, for that matter. Depending on topography and geology, infrasound can travel very far. (In and over the ocean, for huge distances.) Furthermore, infrasound will readily pass through walls—like proverbial butter—oftentimes setting up resonance/vibration patterns within the home, depending on room dimensions.

Again, don't believe me; just remember where you put this article when your Wind Turbine Syndrome kicks in. For some of you it will be pretty quick. For others, more gradual. For those with migraine disorder, you're at special risk, as Pierpont demonstrates statistically.

Migraine disorder? Did you get seasick and carsick as a kid? Then you're motion sensitive. That V90 will make you seasick/carsick again. And worse, because it's long-term.

The end. I promised to be brief. I lied. And, before you ask: *No, there is no cure for WTS.* All you can do is move away. Since the V90 will be operating within specs and code, it won't be turned off. Trust me, they never are.

Go buy a "for sale" sign and hammer it in your front yard.

d'Entremont home, Pubnico Point, Nova Scotia

Then start worrying whether your property is worth anything. After all, your home is acoustically toxic. But that's another sad story for another day. (Just as the windies will load you with documents *proving* that Pierpont is blowing smoke about Wind Turbine Syndrome, they've got another stack of documents *proving* that living near turbines absolutely does not hammer property value. I'm not kidding.)

Daniel & Carolyn d'Entremont pounded a "for sale" sign in their front yard—only to discover no one would buy it. So they locked the door and left. Yes, they are still gypsies, going from rental to rental. Still fighting the wind developer. The good news is, their Wind Turbine Syndrome (which the whole family got) disappeared once they abandoned their home.

So. There you have it. This is what prompted Pierpont to write the following letter to the Wellfleet Town Administrator. [Download it here.](#) And [download Pierpont's c.v. here.](#)

Thanks for the cigarettes. (Don't you know smoking's bad for your health?)

On the way to Naushon (1984)

March 12, 2010

Paul Sieloff, Town Administrator
300 Main
Wellfleet, MA 02667

Dear Mr. Sieloff,

I am told that the Town of Wellfleet is proposing to build an industrial-scale wind turbine as close as 2 km to people's homes.

Permit me to speak plainly. This is a reckless and violent act. The evidence for turbines producing substantial low frequency noise and, worse, infrasound, is no longer in dispute. Second, the clinical evidence is unambiguous that low frequency noise and infrasound profoundly disturb the body's organs of balance, motion, and position sense. Third, the case studies performed by me and other medical doctors have demonstrated unequivocally that people living within 2 km of turbines are made seriously ill, often to the point of abandoning their homes. Fourth, there is no doubt among otolaryngologists and neuro-otologists who have studied the evidence that wind turbine low frequency noise and infrasound are seriously disrupting the body's vestibular organs, resulting in the constellation of illness I have called Wind Turbine Syndrome.

The cure for Wind Turbine Syndrome is simple: Move away from the turbines or shut them off. The prevention of Wind Turbine Syndrome is even simpler: Don't build these low frequency/infrasound-generating machines within 2 km of people's homes. Governments and corporations who violate this principle are guilty of gross clinical harm. Such governments and corporations should be taken before whatever level of court is necessary to stop this outrage.

These are strong words. They are carefully chosen. They are strong because governments and the wind industry stubbornly—I would now add, criminally—refuse to acknowledge that they are deliberately and aggressively harming people. This must stop. The evidence is overwhelming.

I repeat, this must stop.

Sincerely,

Nina Pierpont, MD (Johns Hopkins), PhD (Population Biology, Princeton)
Fellow of the American Academy of Pediatrics
Former Clinical Assistant Professor of Pediatrics,
College of Physicians & Surgeons,
Columbia University

Solar Panels Create Noise Nuisance in Edgartown

Olivia Hull

vineyardgazette.com

Published in the Vineyard Gazette (Martha's Vineyard), Sept 24, 2014

Footnote 6

Smith Hollow is a quiet neighborhood in Edgartown where the ambient sounds include distant traffic and breeze moving through the trees.

But this past summer, the installation of a new municipal solar array added a new sound to the mix: incessant humming that all but drowns out the other sounds at some Smith Hollow residences.

As soon as the solar project went live, inverters, the part of the system that converts direct current from the sun to alternating current, began emitting noise on sunny days. Neighbors complained, and the town hired an expert to investigate.

The inspection revealed that the sound coming from the inverters exceeds ambient sounds in all eight octaves by a significant margin, according to a report discussed by the town selectmen Monday.

"The sound from the inverters is clearly in violation of the Mass. DEP Noise Policy, and also constitutes a noise nuisance, in my opinion, based on the sound level measurements reported here," wrote Lawrence G. Copley, a sound engineer, in the noise assessment he presented to the town.

Mr. Copley's proposed solution is to install an acoustic screen at each inverter pad, deflecting sound away from the nearby residences.

Town administrator Pam Dolby said this solution will exceed state standards and satisfy the neighbors. "He is guaranteeing there will not be an issue if it's done the way he wants to do it," she said.

The array, the largest of two Edgartown town solar projects, is located in an area known as Nunnepog, a Wampanoag name for Edgartown. It was built as part of a series of municipal projects managed by the Cape and Vineyard Electrical Cooperative (CVEC), a group founded in 2007 to oversee renewable energy initiatives. The network of solar panels occupy 5.8 acres and required the removal of trees and other vegetation.

Though mitigation plans are in place for the restoration of vegetation and fencing to obstruct the neighbors' view of the panels, the CVEC says they did not anticipate a noise issue.

"I feel a little bit embarrassed for not knowing that this was going to be a problem because they are classically not very noisy but we clearly have a noisy inverter or more than one that we need to remedy," said Liz Argo, special projects coordinator at CVEC. "So I just wanted to let you know that there are situations where this is not a problem."

But resident James Cimeno said Monday that he and others did raise sound as a possible concern, but were assured that it would not be a problem.

"Right from the start I suggested that they move them because of noise," he said. "We were told they weren't going to make any noise."

Zac Osgood, project manager for the contractor American Capital Energy, said the inverter pads were placed in their present location, beside the residences instead of along the opposite treeline, because of its

convenience to the grid.

His company is also responsible for site maintenance, which neighbors and town officials said has lagged. The site is overgrown with weeds, they said.

“It doesn’t appear that the property is actually being maintained,” Mrs. Dolby said.

Conservation agent Jane Varkonda said the same problems exist at the solar array at Katama, which ACE installed earlier this year.

“We have been asking them to mow, to water the trees, to come in and mulch the trees a little better and also to plant the berm,” she said.

Mr. Osgood said some site work had been done recently, and agreed to give a timeline for the dates of anticipated completion of each of the items on the punch list.

“Our plan is once the site is electrically complete...we bring back the civil guys, so that we make the site beautiful,” he said. “That is our end goal.”

Footnote 7

[thesolarworkroom](#)

[“Solar farm forum gets heated,” Orillia Packet & Times, January 31 2011](#)

June 5, 2011

www.dotorilliapacketdotcom

There wasn't an open chair at the **Simcoe Solar Farm Awareness Project (SSFAP)** symposium held at the Coldwater community centre on Saturday.

Approximately 200 people packed into the upper hall to hear the SSFAP presentation on the importance of preserving agricultural land from largescale solar farms and issues surrounding the construction of these projects.

There are 10 large-scale solar panel projects proposed by **Recurrent Energy**, a San Francisco-based power producer, in Simcoe County, located in **Oro-Medonte, Severn, Springwater** and **Tay** townships.

Marko Smiljanic, SSFAP member, kicked off the symposium with a **presentation on the proposed projects and their impact on agricultural land, such as the stripping of topsoil and the unlikely probability that the land could ever be returned to its original use after the projects' 30-year lease.**

“We should not be displacing food producing land for this type of energy source,” Smiljanic said.

Smiljanic also criticized the Green Energy Act for its exclusion of municipal input on these kinds of projects.

A slate of special guest speakers also addressed the audience on issues surrounding the proposed solar farms.

Frank Coyle, retired civil engineer and former general manager for Simcoe Hydro, spoke about his experience building municipal substations for the production of electricity.

He said the proposed transformers on these solar panel farms are basically like a big substation. The concept is the same, they are moving electrons down the wire to produce energy, and **with that process comes noise.**

“There’s an awful hum to it,” he said. **“If you put that hum in a rural territory, you will hear it for miles.** It becomes the most annoying sound that you will ever experience...It’s a constant hum that you will always hear.”

Maurice McMillan, former employee of **Orillia Water, Light and Power Commission**, discussed the cost model for different forms of electrical generation.

“No cost impact study has been done on solar costing,” McMillan said.

At 64.2 cents per kWh paid by the Ontario Power Authority for all new ground-mounted solar panel project applications to the Feed-in-Tariff program (FIT), he said solar energy gets “really expensive.”

Bernard Pope, founder of **Ontario Farmland Preservation**, encouraged attendees to get involved in fighting the solar farm projects in their area.

“Any obstacle can be moved and the force that is needed is the good citizens and the persistent lobbying of their own,” Pope said.

Harold Boker, an organic farmer in **Tiny Township** who has been farming in the province since 1963, was approached two years ago by a company to lease his land for a solar project. He turned them down.

“I said ‘You better go packing,’ and I warned my neighbours,” Boker said. **“This massive coercion talking young and old farmers into turning their farmland into solar farms... gives me goose-bumps.”**

But not everyone in the room was vehemently opposed to the idea of solar farms in Simcoe County.

When the floor was opened up for a question and answer period, many stood up challenging the opinions and facts of the SSFAP.

One corn farmer inquired what the difference was between farming for the production of ethanol, a clean energy source that has been their livelihood for years, and putting solar panels on a farm.

Robinson replied the difference was that the farmland was still being worked by growing corn for ethanol. It was not being left to bake under these panels.

Robinson’s comment prompted Don Fenwick to stand up and dispel that “myth,” saying he had visited a 100-acre solar farm in Napanee and the soil was in great condition.

“It’s all false. It’s not true,” Fenwick, who owns a farm on Foxmead Road, said.

The Napanee solar farm he visited had its rows of panels separated by a fair distance allowing the soil to stay

healthy and continue to grow grass. Also, **there was very little concrete used to secure the panels**, he said.

Fenwick was approached by a company to build a solar farm on his property.

He declined, not because of the impact on the agricultural land, but because he doesn't agree with the payment structure for solar energy.

"I don't agree with the system that they've got. I'm not against green energy," he said.

Nancy Robinson, chairperson of the SSFAP, was "extremely impressed" with the turnout. She had expected only 50 people to attend.

"To have more than 200 people show up is phenomenal," she said. "The government really needs to stand up and go 'Wow, if a small group of people can assemble that many people over this cause, maybe there's an issue that needs to be addressed here.'"

After the meeting, Robinson said she was happy with people standing up and voicing their opinions — even if they weren't in line with the SSFAP.

"Even the questions at the end which contradicted some of our statements or facts was all good because it's creating debate and awareness. That's what we want to achieve — awareness," she said.

Robinson is hoping that as many people will attend the final public meetings on three of Recurrent Energy's solar farm projects. **If nothing is stopped after this meeting, Recurrent Energy can go ahead with their plans.**

The final meeting for the Orillia 2 project, located on Line 13 N., Hawkestone, is Feb. 10 at 7:15 p.m. at the Township of Oro-Medonte Community Arena, 71 Line 4 N.

The Midhurst 6 project meeting, located on Russell Road in Midhurst, is on Feb. 22 at 6 p.m. at the Elmvale Community Centre, 33 Queen St. W.

The Waubaushene 4 project meeting, located on Quarry Road in Coldwater, and the Waubaushene 5 project, located on Taylor Line in Coldwater, is on Feb. 23 at 6 p.m. at the Coldwater Community Centre, 11 Michael Anne Dr.