

Solutions to CSEC Maths P2 January 2021

SECTION I

Answer ALL questions.

All working must be clearly shown.

1. (a) (i) Using a calculator, or otherwise, calculate the EXACT value of [2]

$$1\frac{4}{7} + \frac{2}{3} - 1\frac{5}{6}$$

$$\begin{aligned} 1\frac{4}{7} + \frac{2}{3} - 1\frac{5}{6} &= \frac{11}{7} + \frac{2}{3} - \frac{11}{6} \\ &= \frac{11(6)+2(14)-11(7)}{42} \\ &= \frac{66+28-77}{42} \\ &= \frac{17}{42} \quad \text{(in exact form)} \end{aligned}$$

- (ii) Write the value of
- $\frac{\sqrt[3]{27}}{9^2}$
- as a fraction in its LOWEST terms. [2]

$$\begin{aligned} \frac{\sqrt[3]{27}}{9^2} &= \frac{3}{81} \\ &= \frac{1}{27} \quad \text{(in its lowest terms)} \end{aligned}$$

(b) The thickness of one sheet of cardboard is given as 485×10^{-2} mm. A construction worker uses 75 sheets of the cardboard, stacked together, to insulate a wall.

(i) Show that the exact thickness of the insulation is 363.75 mm. [1]

$$1 \text{ sheet of cardboard} = 485 \times 10^{-2}$$

$$75 \text{ sheets of cardboard} = 75 \times 485 \times 10^{-2}$$

$$= \frac{1455}{4}$$

$$= 363.75 \text{ mm}$$

(ii) Write the thickness of the insulation

(a) correct to 2 significant figures [1]

$$363.75 = 360 \quad (\text{to 2 significant figures})$$

(b) correct to 1 decimal place [1]

$$363.75 = 363.8 \quad (\text{to 1 decimal place})$$

(c) in standard form [1]

$$363.75 = 3.6375 \times 10^2 \quad (\text{in standard form})$$

(c) Marko is on vacation in the Caribbean. He changes 4500 Mexican pesos (MXN) to Eastern Caribbean dollars (ECD). He receives 630 ECD.

Complete the statement below about the exchange rate.

1 ECD = MXN [1]

$$630 \text{ ECD} = 4500 \text{ MXN}$$

$$1 \text{ ECD} = \frac{4500}{630}$$

$$= \frac{50}{7}$$

$$= 7.14 \quad (\text{to 3 significant figures})$$

Total 9 marks

2. (a) Factorize the following expression completely. [1]

$$12n^2 - 4mn$$

$$12n^2 - 4mn = 4n(3n - m)$$

- (b) (i) Show that $\frac{x}{1-x} - 4x = \frac{x(4x-3)}{1-x}$. [2]

Taking L.H.S:

$$\begin{aligned} \frac{x}{1-x} - 4x &= \frac{x}{1-x} - \frac{4x}{1} \\ &= \frac{x-4x(1-x)}{1-x} \\ &= \frac{x-4x+4x^2}{1-x} \\ &= \frac{-3x+4x^2}{1-x} \\ &= \frac{x(-3+4x)}{1-x} \\ &= \frac{x(4x-3)}{1-x} \end{aligned}$$

$$\therefore \frac{x}{1-x} - 4x = \frac{x(4x-3)}{1-x}$$

Q.E.D.

(ii) Hence, solve the equation

[2]

$$\frac{x}{1-x} - 4x = 0$$

$$\frac{x}{1-x} - 4x = 0$$

$$\frac{x(4x-3)}{1-x} = 0$$

$$x(4x - 3) = 0$$

$$\text{Either } x = 0 \quad \text{or} \quad 4x - 3 = 0$$

$$4x = 3$$

$$x = \frac{3}{4}$$

(c) Make v the subject of the formula $p = \sqrt{5 + vt}$.

[2]

$$p = \sqrt{5 + vt}$$

$$p^2 = (\sqrt{5 + vt})^2$$

$$p^2 = 5 + vt$$

$$p^2 - 5 = vt$$

$$v = \frac{p^2 - 5}{t}$$

- (d) The distance needed to stop a car, d , varies directly as the square of the speed, s , at which it is travelling. A car travelling at a speed of 70 km/h requires a distance of 40 m to make a stop. What distance is required to stop a car travelling at 80 km/h? [2]

$$d \propto s^2$$

$$d = ks^2$$

$$\begin{aligned} \text{Firstly, } 40 \text{ m} &= \frac{40}{1000} \\ &= 0.04 \text{ km} \end{aligned}$$

Substituting $d = 0.04$ and $s = 70$ into $d = ks^2$ gives:

$$0.04 = k(70)^2$$

$$k = \frac{0.04}{4900}$$

So, we have

$$d = ks^2$$

$$= \frac{0.04}{4900} (80)^2$$

$= 0.052 \text{ km}$

$= 52 \text{ m}$

Total 9 marks

3. (a) The diagram below shows two pentagons, P and Q , drawn on a grid made up of squares.

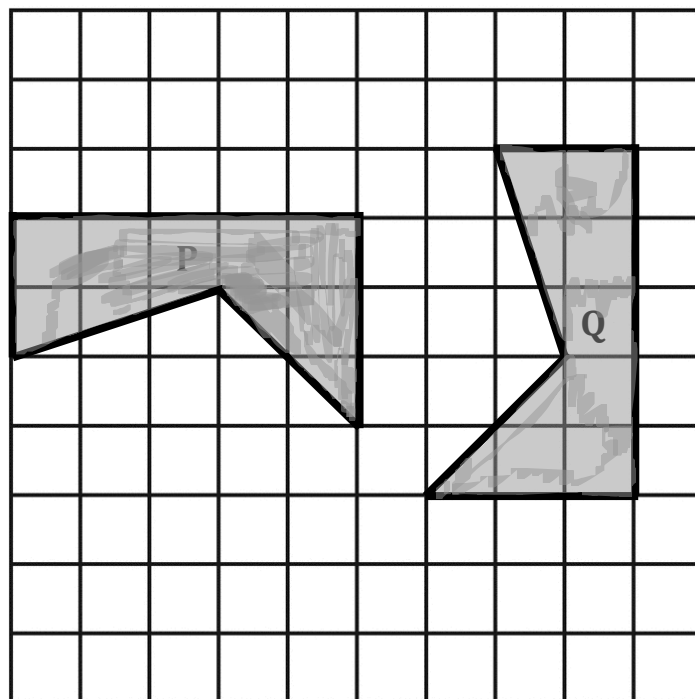

- (i) Select the correct word from the following list to complete the statement below.

opposite	reflected	congruent	translated
----------	-----------	-----------	------------

Pentagon P is **congruent** to Pentagon Q . [1]

(ii) Give the reason for your choice in (a) (i). [1]

The corresponding angles and sides are of equal length. Pentagon P can be mapped on to Pentagon Q .

(b) The diagram below, **not drawn to scale**, shows the pentagon $VWXYZ$. In the pentagon, YZ is parallel to XW and YX is parallel to VW . Angle $XYZ = 114^\circ$ while angle $VZY = 98^\circ$.

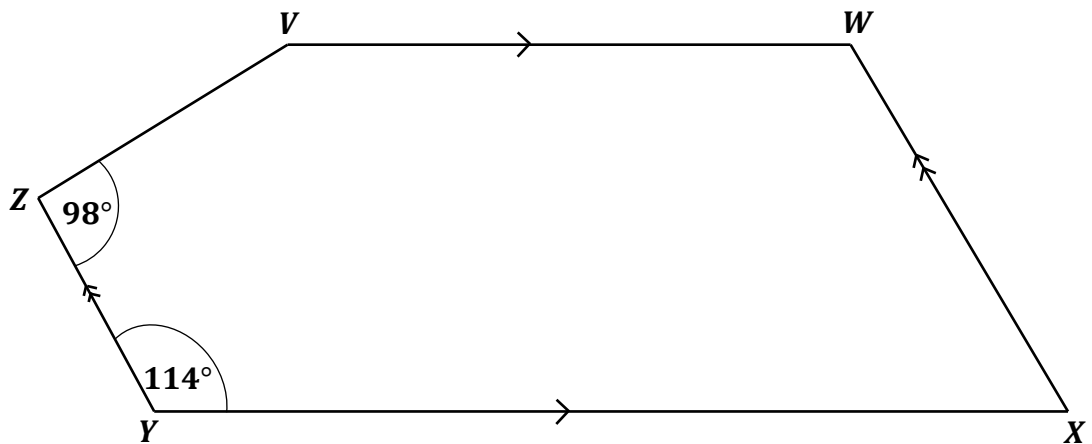

Determine the value of

(i) angle WXY [1]

When parallel lines (XW and YZ) are cut by a transversal (YX), the co-interior angles are supplementary.

$$\widehat{ZYX} + \widehat{WXY} = 180^\circ$$

$$114^\circ + \widehat{WXY} = 180^\circ$$

$$\widehat{WXY} = 180^\circ - 114^\circ$$

$$\widehat{WXY} = 66^\circ$$

(ii) angle ZVW

[2]

Co-interior angles are supplementary.

$$\widehat{XWV} + \widehat{WXY} = 180^\circ$$

$$\widehat{XWV} + 66^\circ = 180^\circ$$

$$\widehat{XWV} = 180^\circ - 66^\circ$$

$$\widehat{XWV} = 114^\circ$$

$$\text{Internal angles in a pentagon} = (n - 2)180^\circ$$

$$= (5 - 2)180^\circ$$

$$= (3)180^\circ$$

$$= 540^\circ$$

Hence,

$$\widehat{ZVW} = 540^\circ - (114^\circ + 114^\circ + 98^\circ + 66^\circ)$$

$$= 540^\circ - 392^\circ$$

$$= 148^\circ$$

(c) The letter 'A' and a point C(6, 6) are shown on the grid below.

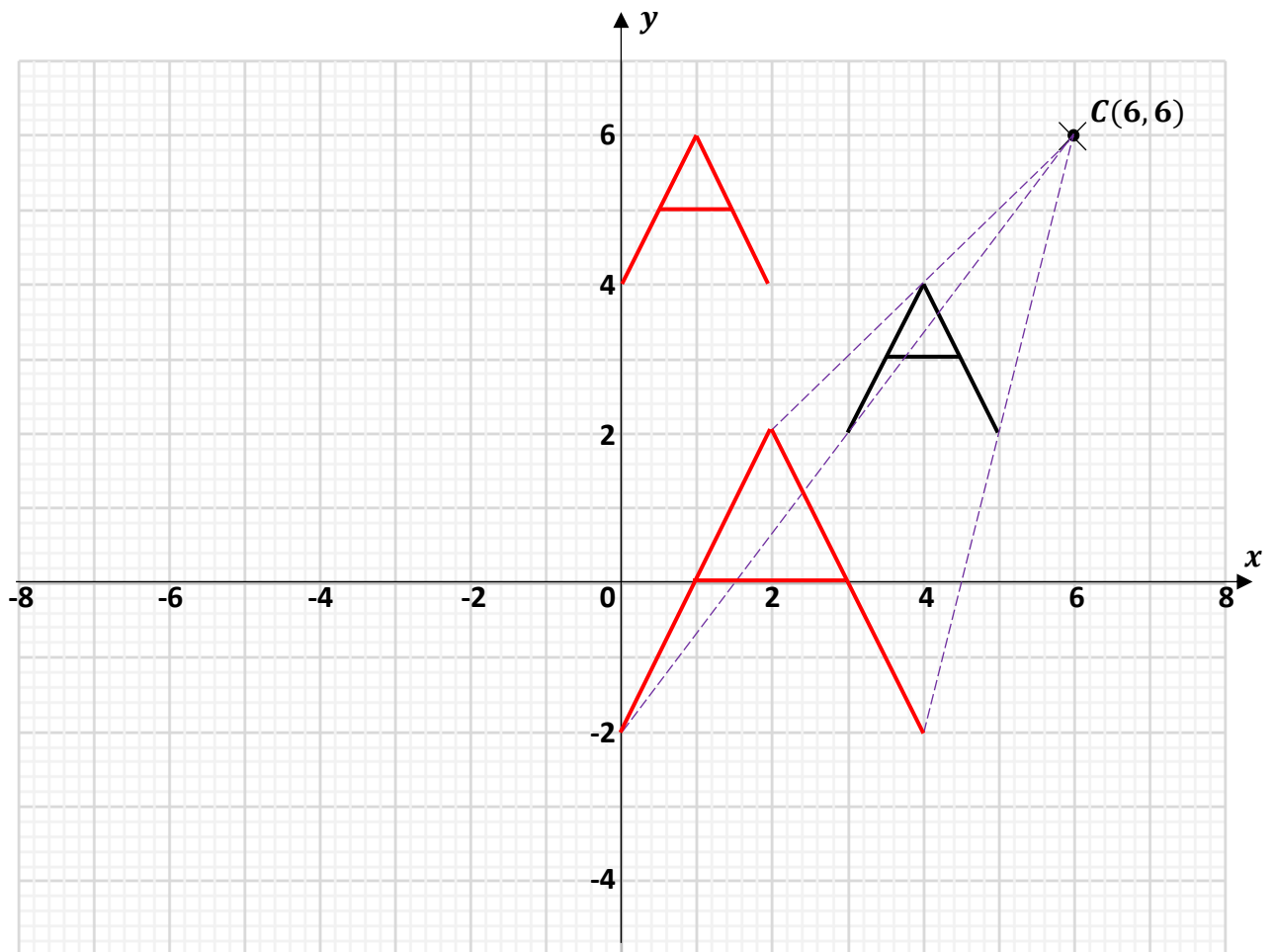

On the diagram, draw accurately, EACH of the following transformations.

- (i) The enlargement of letter 'A' by scale factor 2, about centre, $C(6, 6)$. [2]

(See diagram above.)

- (ii) The translation of letter 'A' using the vector $T = \begin{pmatrix} -3 \\ 2 \end{pmatrix}$. [2]

(See diagram above.)

Total 9 marks

4. (a) The function f is defined as

$$f: x \rightarrow 3 - 2x.$$

- (i) The diagram below shows the mapping diagram of the function, f .
Determine the value of a .

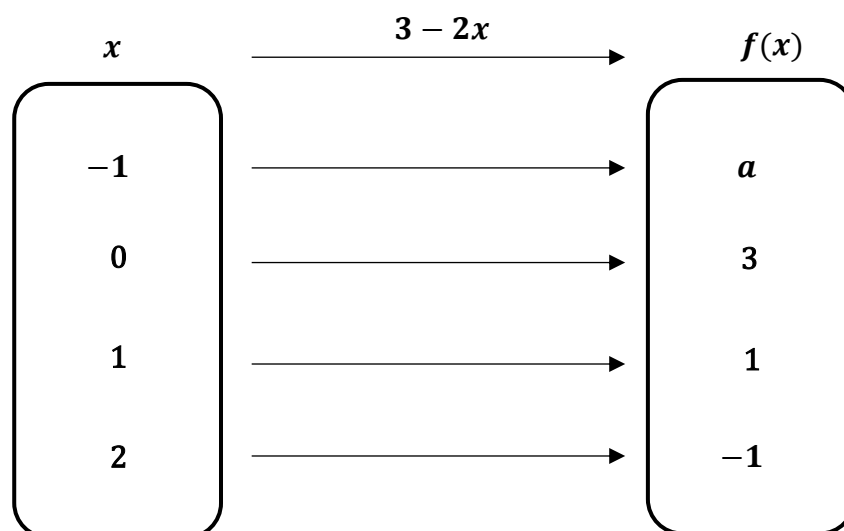

$$a = \dots\dots\dots 5 \dots\dots\dots \quad [1]$$

$$\begin{aligned} f(-1) &= 3 - 2(-1) \\ &= 3 - (-2) \\ &= 3 + 2 \\ &= 5 \end{aligned}$$

$$\therefore a = 5$$

(ii) Determine, in their simplest form, expressions for

(a) the inverse of the function $f, f^{-1}(x)$ [1]

$$f(x) = 3 - 2x$$

Let $y = f(x)$.

$$y = 3 - 2x$$

Interchange variables x and y .

$$x = 3 - 2y$$

Make y the subject of the formula.

$$x - 3 = -2y$$

$$2y = 3 - x$$

$$x = \frac{3-x}{2}$$

$$\therefore f^{-1}(x) = \frac{3-x}{2}$$

(b) the **composite** function $f^2(x)$ [2]

$$\begin{aligned} f^2(x) &= f[f(x)] \\ &= f(3 - 2x) \\ &= 3 - 2(3 - 2x) \\ &= 3 - 6 + 4x \\ &= -3 + 4x \\ &= 4x - 3 \end{aligned}$$

(iii) State the value of $ff^{-1}(-2)$. [1]

$$\begin{aligned} f^{-1}(x) &= \frac{3-x}{2} \\ f^{-1}(-2) &= \frac{3-(-2)}{2} \\ &= \frac{3+2}{2} \\ &= \frac{5}{2} \end{aligned}$$

$$\begin{aligned} ff^{-1}(-2) &= f\left(\frac{5}{2}\right) \\ &= 3 - 2\left(\frac{5}{2}\right) \end{aligned}$$

$$= 3 - 5$$

$$= -2$$

(b) (i) Using a ruler, draw the lines $x = \frac{1}{2}$, $y = x$ and $x + y = 5$, on the grid below. [3]

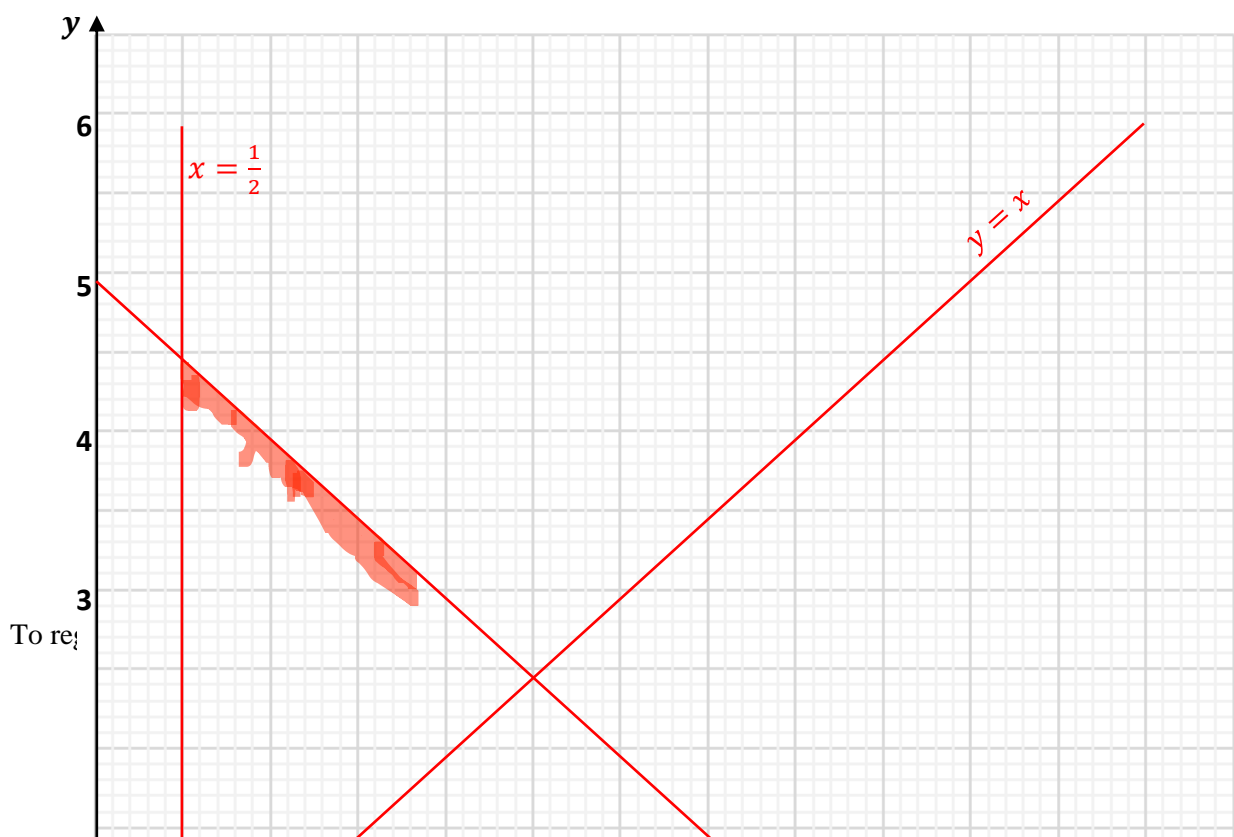

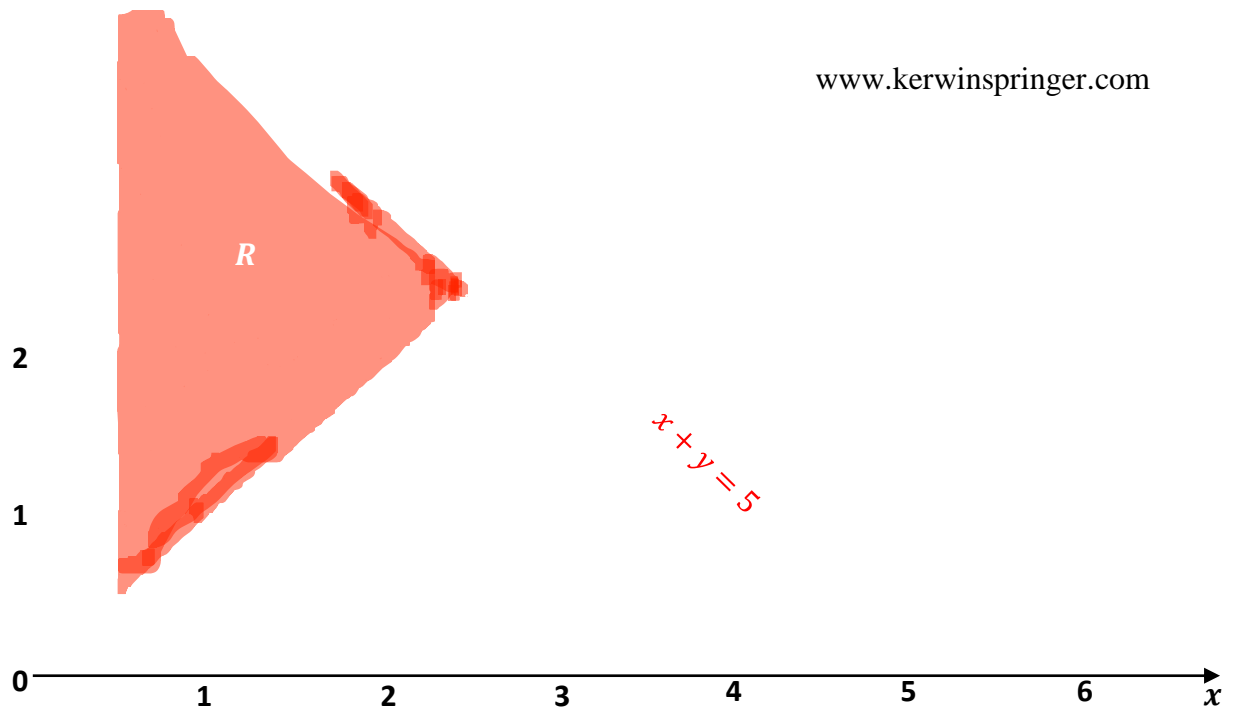

- (ii) On the grid, label as R , the region where $x \geq \frac{1}{2}$, $y \geq x$ and $x + y \leq 5$. [1]

(See diagram above.)

Total 9 marks

5. (a) Sixty students took an algebra test, which comprised 15 multiple choice questions. The number of correct answers that each student obtained is recorded in the table below.

Number of Correct Answers	Number of Students
8	6
9	14

10	2
11	6
12	2
13	11
14	9
15	10

Using the table, determine

- (i) the number of students who had exactly 13 correct answers [1]

The number of students who had exactly 13 correct answers is 11.

- (ii) the modal number of correct answers [1]

The modal number of correct answers is 9.

- (iii) the median number of correct answers [1]

The median occurs at $\frac{n+1}{2}$ th value which is,

$$\frac{n+1}{2} = \frac{60+1}{2}$$

$$= \frac{61}{2}$$

$$= 30.5^{\text{th}} \text{ value}$$

The 30th value is 12.

The 31st value is 13.

$$\begin{aligned} \text{Median number of correct answers} &= \frac{12+13}{2} \\ &= 12.5 \end{aligned}$$

- (iv) the probability that a student chosen at random had at **least** 12 correct answers. [1]

$$\begin{aligned} P(\text{student had at least 12 answers}) &= \frac{\text{Number of desired outcomes}}{\text{Total number of possible outcomes}} \\ &= \frac{2+11+9+10}{60} \\ &= \frac{32}{60} \\ &= \frac{8}{15} \end{aligned}$$

- (b) A group of students wrote a Physics examination. Each of the students achieved a Grade I, II, III or IV. The pie chart below shows the results.

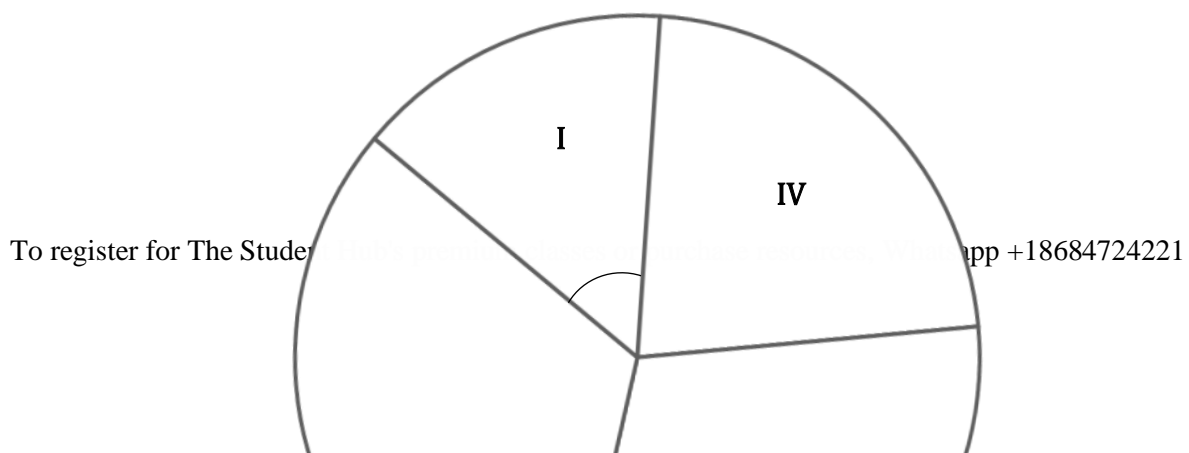

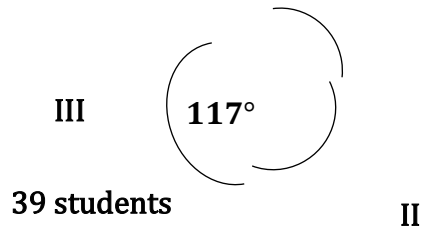

Thirty-nine students achieved a Grade III.

- (i) Determine the TOTAL number of students who wrote the examination. [2]

$$117^\circ = 39 \text{ students}$$

$$1^\circ = \frac{39}{117}$$

$$360^\circ = \frac{39}{117} \times 360$$

$$= 120 \text{ students}$$

- (ii) The ratio of the number of students who achieved a Grade I, II or IV is 2:4:3.

A student passed the examination if he/she achieved a Grade I, II or III.

How many students passed the examination? [2]

$$I : II : IV$$

$$2 : 4 : 3$$

This ratio totals 243° .

$$9 \text{ parts} = 243^\circ$$

$$1 \text{ part} = \frac{243^\circ}{9}$$

$$= 27^\circ$$

$$\text{Grade I} = 2 \times 27^\circ$$

$$= 54^\circ$$

$$\text{Grade II} = 4 \times 27^\circ$$

$$= 108^\circ$$

$$\text{Grade IV} = 3 \times 27^\circ$$

$$= 81^\circ$$

$$\text{Students passing} = \text{Grade I} + \text{Grade II} + \text{Grade IV}$$

$$= 54^\circ + 108^\circ + 81^\circ$$

$$= 279^\circ$$

$$1^\circ = \frac{39}{117}$$

$$279^\circ = \frac{39}{117} \times 279$$

$$= 93 \text{ students}$$

∴ The number of students who passed the examination is 93 students.

- (iii) Determine the value of the angle for the sector representing Grade I in the pie chart. [1]

$$\begin{aligned}\text{The angle of the sector representing Grade 1} &= 2 \times 27^\circ \\ &= 54^\circ\end{aligned}$$

Total 9 marks

6. In this question, take π to be $\frac{22}{7}$.

The diagram below shows a rectangular tank, with base 50 cm by 40 cm, that is used to store water. The tank is filled with water to a depth of 15 cm.

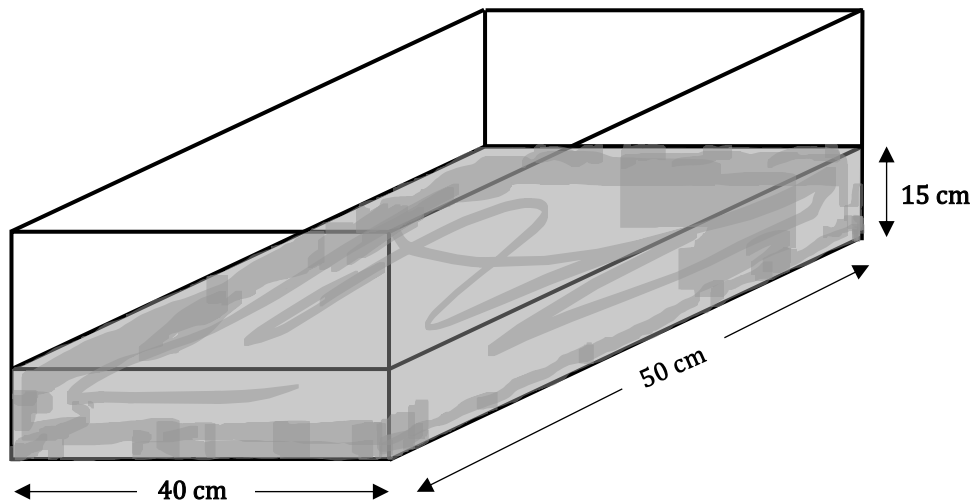

(a) Calculate the volume of water in the tank.

[2]

$$\text{Volume of water in the tank} = l \times b \times h$$

$$= 40 \times 50 \times 15$$

$$= 30\,000 \text{ cm}^3$$

(b) The cylindrical container shown in the diagram below is used to fetch **more** water to fill the rectangular tank. The container, which is completely filled with water, has a radius of 20 cm and a height of 21 cm.

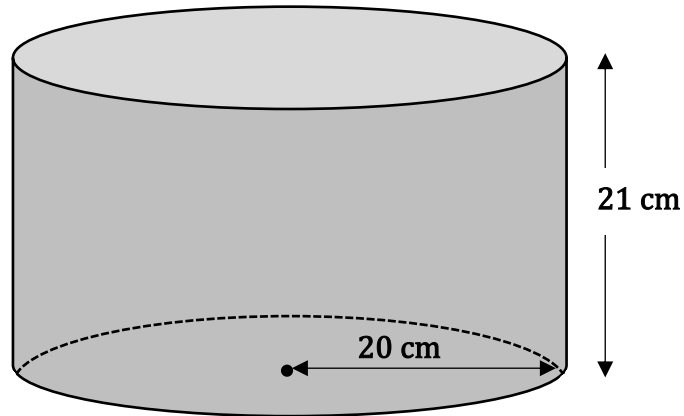

All the water in this container is added to the water in the rectangular tank.
Calculate the TOTAL volume of water that is now in the rectangular tank. [3]

$$\begin{aligned}\text{Volume of the cylindrical container} &= \pi r^2 h \\ &= \frac{22}{7} \times (20)^2 \times 21 \\ &= 26\,400 \text{ cm}^3\end{aligned}$$

After the water from the cylindrical container is added,

$$\begin{aligned}\text{Total volume of water in rectangular tank} &= 30\,000 + 26\,400 \\ &= 56\,400 \text{ cm}^3\end{aligned}$$

(c) Show that the **new** depth of water in the rectangular tank is 28.2 cm. [2]

Volume of water in the rectangular tank = $56\,400\text{ cm}^3$

Let h represent the new depth of water.

Then, we have,

$$50 \times 40 \times h = 56\,400$$

$$h = \frac{56\,400}{50 \times 40}$$

$$h = \frac{56\,400}{2\,000}$$

$$h = 28.2\text{ cm}$$

- (d) The vertical height of the rectangular tank is 48 cm . Determine how many more cylindrical containers of water must be poured into the rectangular tank for it to be completely filled. [2]

Volume of the rectangular tank = $l \times b \times h$

$$= 40 \times 50 \times 48$$

$$= 96\,000\text{ cm}^3$$

Volume of water already in the tank = $56\,400\text{ cm}^3$

Additional volume of water needed to fill the rectangular tank

$$= 96\,000 - 56\,400$$

$$= 39\,600\text{ cm}^3$$

1 cylindrical container has a volume of $26\,400\text{ cm}^3$.

$$\begin{aligned}\text{Required number of cylindrical containers} &= \frac{39\,600}{26\,400} \\ &= 1.5 \text{ containers}\end{aligned}$$

Total 9 marks

7. The diagrams below show a sequence of figures made up of circles with dots. Each figure has one dot at the centre and 4 dots on the circumference of each circle. The radius of the first circle is one unit. The radius of each new circle is one unit greater than the radius of the previous circle. Except for the first figure, a portion of each of the other figures is shaded.

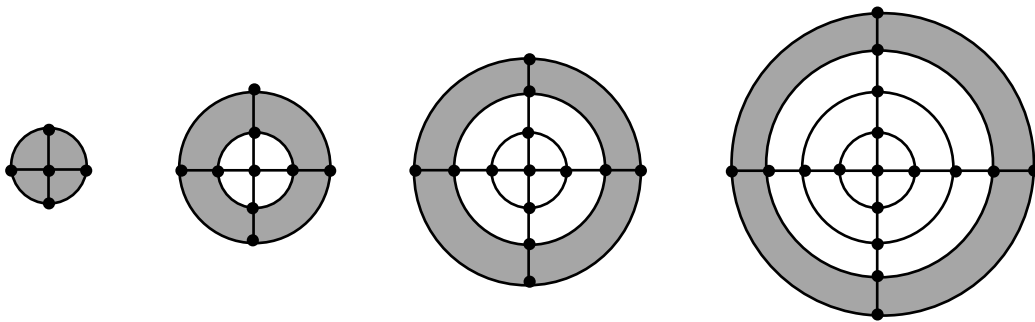

Figure 1

Figure 2

Figure 3

Figure 4

(a) Complete the rows in the table below for Figure 5 and Figure n .

Figure Number	Number of Dots	Area of Outer (Largest) Circle	Area of Shaded Region	Total Length of Circumference of all Circles
1	5	π	π	2π
2	9	4π	3π	6π
3	13	9π	5π	12π
4	17	16π	7π	20π
(i) 5	_____	25π	_____	_____
\vdots	\vdots	\vdots	\vdots	\vdots

[3]

(ii)

[4]

n	_____	_____	_____	_____
-----	-------	-------	-------	-------

Consider the n th figure.

$$\text{Number of dots} = 4n + 1$$

$$\text{Area of Outer (Largest) Circle} = n^2\pi$$

$$\text{Area of shaded region} = (2n - 1)\pi$$

$$\text{Total length of Circumference of all Circles} = n(n + 1)\pi$$

When $n = 5$,

$$\text{Number of dots} = 4(5) + 1$$

$$= 20 + 1$$

$$= 21$$

When $n = 5$,

$$\text{Area of shaded region} = (2n - 1)\pi$$

$$= (2(5) - 1)\pi$$

$$= (10 - 1)\pi$$

$$= 9\pi$$

When $n = 5$,

$$\text{Total length of Circumference of all Circles} = 5(5 + 1)\pi$$

$$= 5(6)\pi$$

$$= 30\pi$$

(b) Determine the value of n , when the number of dots in Figure n is 541. [2]

$$\text{Number of dots} = 4n + 1$$

So, we have,

$$541 = 4n + 1$$

$$541 - 1 = 4n$$

$$540 = 4n$$

$$4n = 540$$

$$n = \frac{540}{4}$$

$$n = 135$$

\therefore When the number of dots in Figure n is 541, the value of $n = 135$.

(c) Write down, in terms of p and π , the area of the LARGEST circle in Figure $3p$. [1]

When $n = 3p$,

$$\text{Area of the largest circle} = n^2\pi$$

$$= (3p)^2\pi$$

$$= 9p^2\pi$$

Total 10 marks

SECTION II

Answer ALL questions.

ALGEBRA, RELATIONS, FUNCTIONS AND GRAPHS

8. (a) The straight line graph of $x = 5 - 3y$ intersects the x -axis at P and the y -axis at Q .

(i) Determine the coordinates of P and Q . [2]

$P(\dots\dots, \dots\dots)$ $Q(\dots\dots, \dots\dots)$

A line cuts the x -axis at $y = 0$.

When $y = 0$,

$$x = 5 - 3(0)$$

$$= 5 - 0$$

$$= 5$$

\therefore The coordinates of P are $(5, 0)$.

A line cuts the y -axis at $x = 0$.

When $x = 0$,

$$0 = 5 - 3y$$

$$3y = 5$$

$$y = \frac{5}{3}$$

∴ The coordinates of Q are $\left(0, \frac{5}{3}\right)$.

- (ii) Calculate the length of PQ , giving your answer to 2 decimal places. [2]

Point $P(5, 0)$ and Point $Q\left(0, \frac{5}{3}\right)$.

$$\begin{aligned} \text{Length of } PQ &= \sqrt{(x_2 - x_1)^2 + (y_2 - y_1)^2} \\ &= \sqrt{(0 - 5)^2 + \left(\frac{5}{3} - 0\right)^2} \\ &= \sqrt{(-5)^2 + \left(\frac{5}{3}\right)^2} \\ &= \sqrt{25 + \frac{25}{9}} \\ &= \sqrt{\frac{250}{9}} \\ &= 5.27 \text{ units} \quad (\text{to 2 decimal places}) \end{aligned}$$

- (iii) R is the midpoint of PQ . Determine the coordinates of R . [1]

$$\begin{aligned} \text{Midpoint of } PQ, R &= \left(\frac{x_1+x_2}{2}, \frac{y_1+y_2}{2}\right) \\ &= \left(\frac{0+5}{2}, \frac{\frac{5}{3}+0}{2}\right) \end{aligned}$$

$$= \left(\frac{5}{2}, \frac{\frac{5}{3}}{2} \right)$$

$$= \left(\frac{5}{2}, \frac{5}{6} \right)$$

\therefore The coordinates of R are $\left(\frac{5}{2}, \frac{5}{6} \right)$.

(b) The functions f and g are defined as follows

$$f: x \rightarrow 5 - x \text{ and } g: x \rightarrow x^2 - 2x - 1$$

The graphs of $f(x)$ and $g(x)$ meet at points M and N . Determine the coordinates of the points M and N . [4]

$$f(x) = 5 - x$$

$$g(x) = x^2 - 2x - 1$$

We need to solve simultaneously to find M and N .

$$y = 5 - x \quad \rightarrow \text{Equation 1}$$

$$y = x^2 - 2x - 1 \quad \rightarrow \text{Equation 2}$$

Equating Equation 1 and Equation 2 gives:

$$5 - x = x^2 - 2x - 1$$

$$x^2 - 2x - 1 + x - 5 = 0$$

$$x^2 - x - 6 = 0$$

$$x^2 - 3x + 2x - 6 = 0$$

$$x(x - 3) + 2(x - 3) = 0$$

$$(x + 2)(x - 3) = 0$$

$$\text{Either } x + 2 = 0 \quad \text{or} \quad x - 3 = 0$$

$$x = -2$$

$$x = 3$$

When $x = -2$,

$$y = 5 - (-2)$$

$$y = 5 + 2$$

$$y = 7$$

When $x = 3$,

$$y = 5 - 3$$

$$y = 2$$

\therefore The coordinates are $M(-2, 7)$ and $N(3, 2)$.

(c) Monty is cycling at 12 metres per second (m/s). After 4.5 seconds he starts to decelerate and after a further 2.5 seconds he stops. The speed-time graph is shown below.

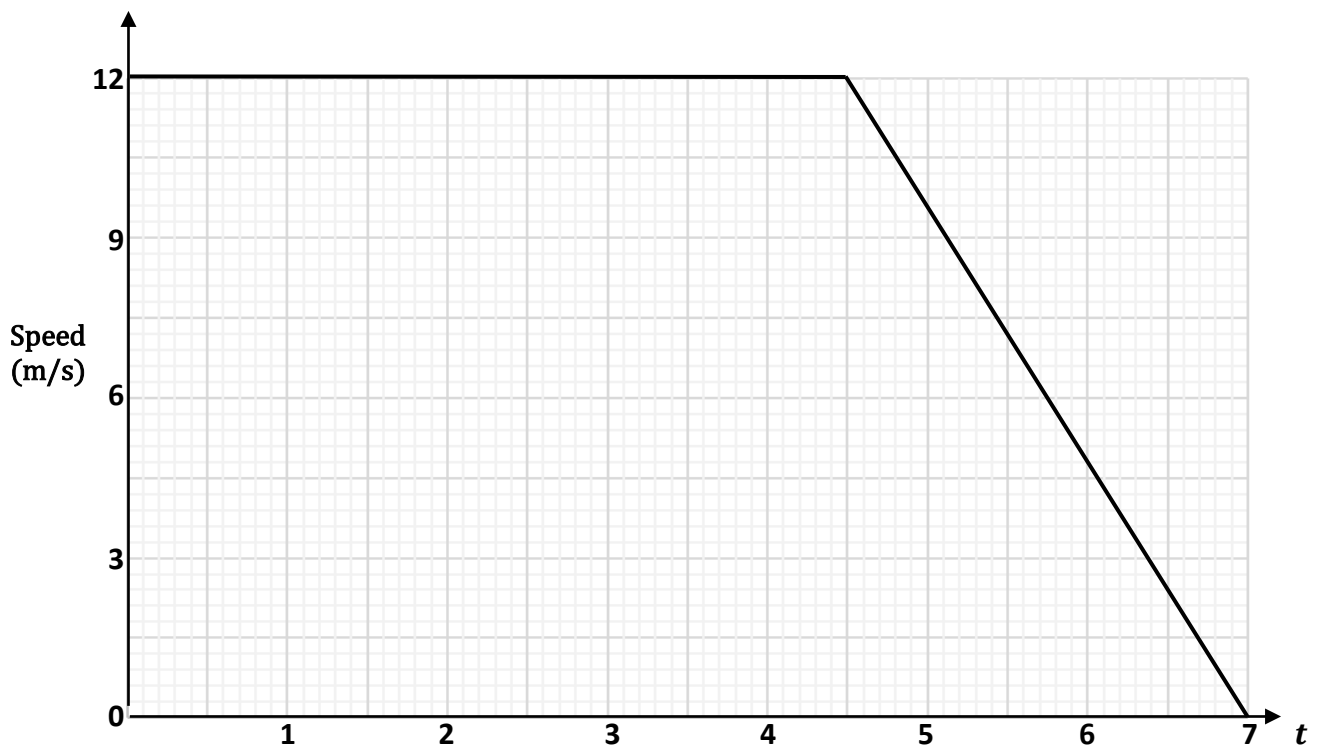

Calculate

- (i) the constant deceleration [1]

Points are (7, 0) and (4.5, 12).

$$\begin{aligned} \text{Gradient} &= \frac{y_2 - y_1}{x_2 - x_1} \\ &= \frac{12 - 0}{4.5 - 7} \\ &= \frac{12}{-2.5} \\ &= -4.8 \text{ ms}^{-2} \end{aligned}$$

Since the acceleration is -4.8 ms^{-2} , then the deceleration is 4.8 ms^{-2} .

- (ii) Monty's average speed over the 7 seconds [2]

Distance covered = Area under the graph

$$\begin{aligned} &= \frac{1}{2}(4.5 + 7) \times 12 \\ &= 69 \text{ m} \end{aligned}$$

$$\begin{aligned} \text{Average Speed} &= \frac{\text{Total distance covered}}{\text{Total time taken}} \\ &= \frac{69}{7} \\ &= 9.86 \text{ ms}^{-1} \quad (\text{to 3 significant figures}) \end{aligned}$$

Total 12 marks

GEOMETRY AND TRIGONOMETRY

9. (a) In the diagram below, A, B, C and D are points on the circumference of a circle, with centre O , AOC and BOD are diameters of the circle. AB and DC are parallel.

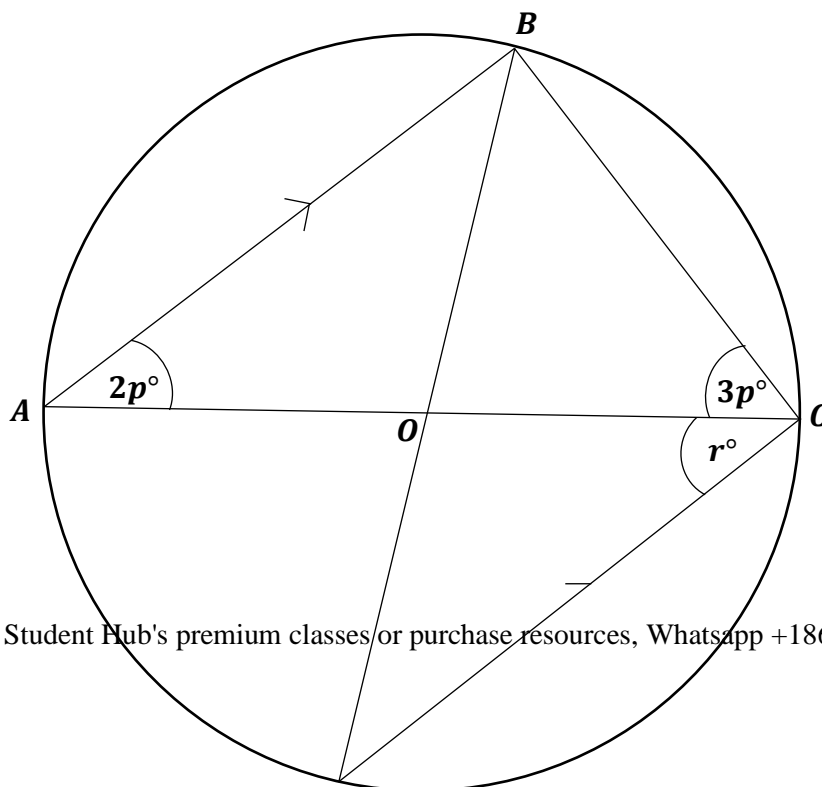

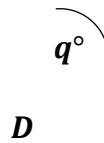

- (i) State the reason why angle ABC is 90° . [1]

O is the centre of the circle. So, line AOC is a diameter of the circle.

The angle formed in a semicircle is always a right angle.

Hence, angle $ABC = 90^\circ$.

- (ii) Determine the value of EACH of the following angles. Show detailed working where necessary and give a reason to support your answer.

- (a) Angle BAC [2]

Consider $\triangle ABC$.

The sum of the angles in a triangle add up to 180° .

Hence,

$$90^\circ + 2p^\circ + 3p^\circ = 180^\circ$$

$$5p^\circ = 180^\circ - 90^\circ$$

$$5p^\circ = 90^\circ$$

$$p^\circ = \frac{90^\circ}{5}$$

$$= 18^\circ$$

$$\begin{aligned}\text{Now, } \widehat{BAC} &= 2p \\ &= 2(18) \\ &= 36^\circ\end{aligned}$$

(b) Angle q [2]

Angles from the same chord in the same segment are equal.

$$\text{So, } \widehat{BDC} = \widehat{BAC}.$$

Hence, angle $q = 36^\circ$.

(iii) Calculate the value of angle r . [1]

Consider $\triangle BCD$.

Since the angle in a semi-circle is 90° , then $\widehat{BCD} = 90^\circ$.

So, we have,

$$r + 3p = 90^\circ$$

$$r + 3(18) = 90$$

$$r + 54 = 90$$

$$r = 90 - 54$$

$$r = 36$$

\therefore Angle $r = 36^\circ$

(b) From a harbour, H , the bearing of two buoys, S and Q , are 185° and 311° respectively. Q is 5.4 km from H while S is 3.5 km from H .

(i) On the diagram below, which shows the sketch of this information, insert the value of the marked angle, QHS . [1]

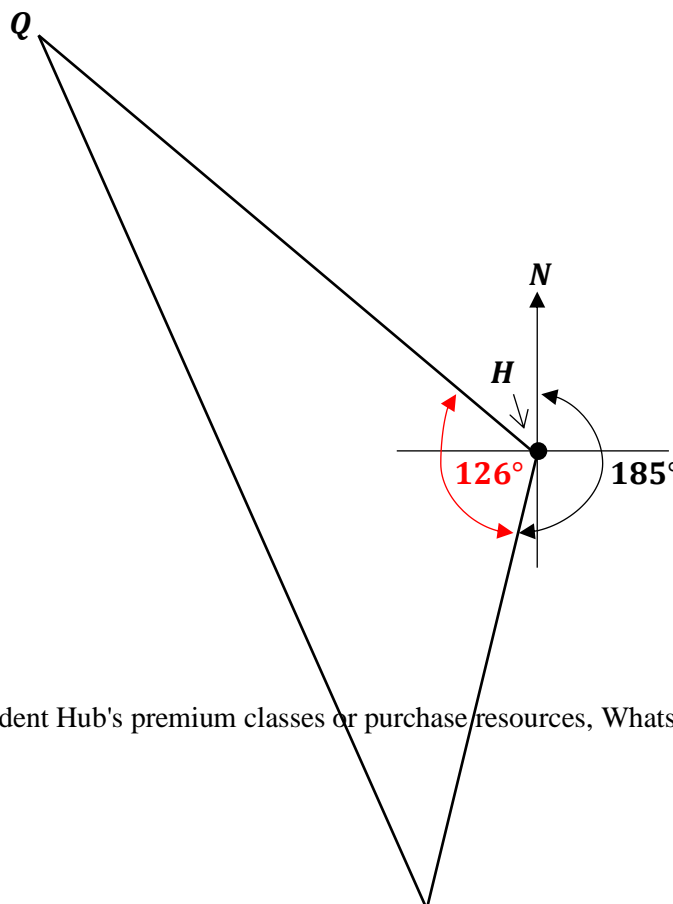

S

$$\begin{aligned} Q\hat{H}S &= 311^\circ - 185^\circ \\ &= 126^\circ \end{aligned}$$

(ii) Calculate QS , the distance between the two buoys. [2]

Consider $\triangle QHS$. Using the cosine rule,

$$\begin{aligned} QS^2 &= QH^2 + SH^2 - 2(QH)(SH) \cos Q\hat{H}S \\ &= (5.4)^2 + (3.5)^2 - 2(5.4)(3.5) \cos 126^\circ \\ &= 29.16 + 12.25 - (-22.218) \\ &= 63.628 \\ QS &= \sqrt{63.628} \\ &= 7.98 \text{ km} \quad (\text{to 2 decimal places}) \end{aligned}$$

(iii) Calculate the bearing of S from Q . [3]

Using the sine rule,

$$\frac{3.5}{\sin H\hat{Q}S} = \frac{7.977}{\sin 126^\circ}$$

$$\sin H\hat{Q}S = \frac{3.5 \times \sin 126^\circ}{7.977}$$

$$\sin H\hat{Q}S = 0.355$$

$$H\hat{Q}S = \sin^{-1}(0.355)$$

$$= 20.8^\circ$$

$$\therefore \text{The bearing of } S \text{ from } Q = 90^\circ + 41^\circ + 20.8^\circ$$

$$= 151.8^\circ$$

Total 12 marks

VECTORS AND MATRICES

10. (a) Given the matrix $W = \begin{pmatrix} 3 & 6 \\ -2 & 5 \end{pmatrix}$, determine

(i) the 2×2 matrix, L , such that $W + L = \begin{pmatrix} 0 & 0 \\ 0 & 0 \end{pmatrix}$ [1]

$$W + L = \begin{pmatrix} 0 & 0 \\ 0 & 0 \end{pmatrix}$$

$$\begin{pmatrix} 3 & 6 \\ -2 & 5 \end{pmatrix} + L = \begin{pmatrix} 0 & 0 \\ 0 & 0 \end{pmatrix}$$

$$L = \begin{pmatrix} 0 & 0 \\ 0 & 0 \end{pmatrix} - \begin{pmatrix} 3 & 6 \\ -2 & 5 \end{pmatrix}$$

$$= \begin{pmatrix} 0 - 3 & 0 - 6 \\ 0 - (-2) & 0 - 5 \end{pmatrix}$$

$$= \begin{pmatrix} -3 & -6 \\ 2 & -5 \end{pmatrix}$$

(ii) the 2×2 matrix, P , such that $WP = \begin{pmatrix} 1 & 0 \\ 0 & 1 \end{pmatrix}$ [2]

$$WP = \begin{pmatrix} 1 & 0 \\ 0 & 1 \end{pmatrix}$$

$$P = W^{-1} \begin{pmatrix} 1 & 0 \\ 0 & 1 \end{pmatrix}$$

$$\det(W) = ad - bc$$

$$= (3)(5) - (6)(-2)$$

$$= 15 - (-12)$$

$$= 15 + 12$$

$$= 27$$

(b) A right-angled triangle, M , has vertices $X(1, 1)$, $Y(3, 1)$ and $Z(3, 4)$. When M is transformed by the matrix $N = \begin{pmatrix} 0 & 1 \\ 1 & 0 \end{pmatrix}$, the image is M' .

Find the coordinates of the vertices of M' . [2]

The transformation matrix $N = \begin{pmatrix} 0 & 1 \\ 1 & 0 \end{pmatrix}$ is a reflection in the line $y = x$.

$$X(1, 1) \rightarrow X'(1, 1)$$

$$Y(3, 1) \rightarrow Y'(1, 3)$$

$$Z(3, 4) \rightarrow Z'(4, 3)$$

Hence, the coordinates of the vertices M' are $X'(1, 1)$, $Y'(1, 3)$ and $Z'(4, 3)$.

(c) The diagram below shows triangle OPQ in which $\overrightarrow{OP} = 3u$ and $\overrightarrow{OQ} = v$. Q is the midpoint of OR and M is the midpoint of PQ . L is a point on OP such that $OL = \frac{2}{3}OP$.

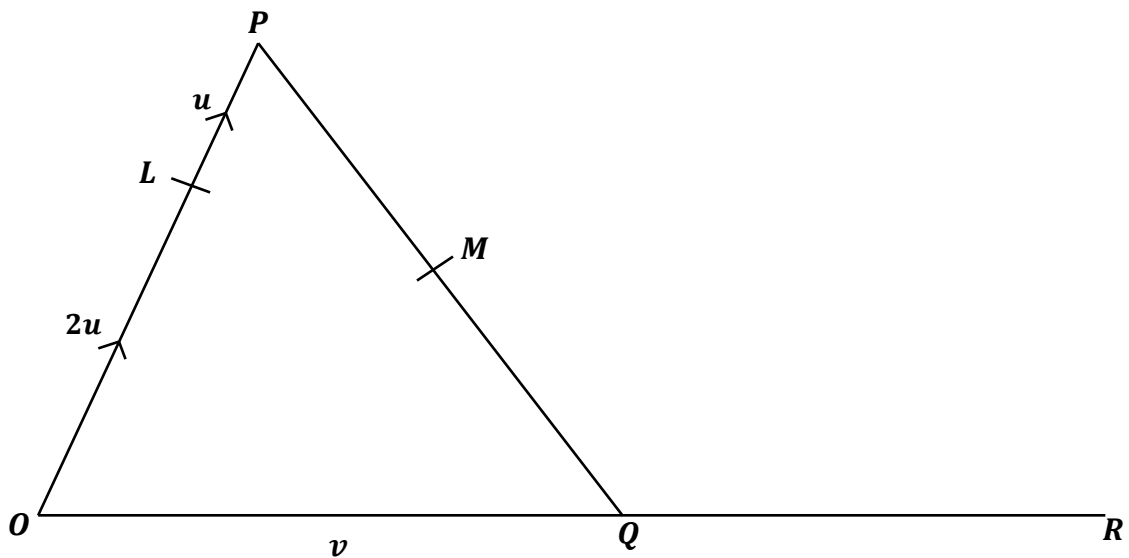

(i) Write in terms of u and v , an expression for

(a) \overrightarrow{LM} [2]

$$\begin{aligned}\overrightarrow{PM} &= \frac{1}{2}\overrightarrow{PQ} \\ &= \frac{1}{2}(\overrightarrow{PO} + \overrightarrow{OQ}) \\ &= \frac{1}{2}(-3u + v)\end{aligned}$$

$$\begin{aligned}\overrightarrow{LM} &= \overrightarrow{LP} + \overrightarrow{PM} \\ &= u + \frac{1}{2}(-3u + v)\end{aligned}$$

$$\begin{aligned}
 &= u - \frac{3}{2}u + \frac{1}{2}v \\
 &= -\frac{1}{2}u + \frac{1}{2}v \\
 &= \frac{1}{2}(-u + v) \quad \text{or} \quad \frac{1}{2}(v - u)
 \end{aligned}$$

(b) \overrightarrow{PR} [1]

$$\begin{aligned}
 \overrightarrow{PR} &= \overrightarrow{PO} + \overrightarrow{OR} \\
 &= -(3u) + 2v \\
 &= -3u + 2v
 \end{aligned}$$

(ii) Prove that the points L , M and R are collinear. [4]

$$\begin{aligned}
 \overrightarrow{LM} &= \frac{1}{2}(-u + v) \\
 2\overrightarrow{LM} &= -u + v \\
 \overrightarrow{LR} &= \overrightarrow{LO} + \overrightarrow{OR} \\
 &= -2u + 2v \\
 &= 2(-u + v) \\
 &= 2(2\overrightarrow{LM}) \\
 &= 4\overrightarrow{LM}
 \end{aligned}$$

\overrightarrow{LR} is scalar multiple of \overrightarrow{LM} .

Since LR is parallel to LM and L is a common point to both lines, then, L , M and R are collinear.

Total 12 marks

END OF TEST

IF YOU FINISH BEFORE TIME IS CALLED, CHECK YOUR WORK ON THIS TEST.