

C1

Zentrischspanner  
Centric vice

8

**Backenschnellwechsel, komplett gekapselt, präzise**

Zentrischspanner C1 in mechanischer Ausführung mit 100% Kapselung und Backenschnellwechsel. Ideal geeignet für Roh-  
teil- und Fertigteilbearbeitung, Mehrfach-Spannungen und Au-  
tomation auf Palettspeichern.

**Quick jaw change, fully encapsulated, precise**

Centric vice C1 in mechanical version with 100% encapsulation and quick jaw change. Ideally suited for machin-  
ing blanks and finished products, multiple clamping and automation of pallet storage.



## **Backenschnellwechsel**

- Backenwechsel in wenigen Sekunden
- einfaches Handling
- unterschiedliche Wechselbacken

## **Quick jaw change**

- jaw change in a few seconds
- easy handling
- different jaws

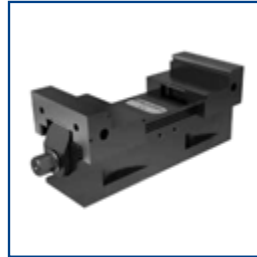

## **Komplett gekapselt + präzise**

- komplett geschlossenes System
- günstige Version für die Rohteilspannung mit Wendebacken grip
- präzise Version zum Spannen von Fertigteilen mit Backen, die im gespannten Zustand überschliffen werden

## **Fully encapsulated + precise**

- completely encapsulated system
- economic version for blank clamping with reversible grip jaw
- precise version for clamping finished parts with jaws which are ground in clamped position



## **Spannsystem für die Automation**

- direkt integrierbar in Paletten – idealer Einsatz im GRESSEL Werkstückspeicher
- zentrische Mehrfachspannung auf Grundplatten oder Türmen
- kostengünstige Lösung für Palettenspeicher
- adaptierbar für verschiedene markt- begleitende Nullpunkt-Spannsysteme

## **Clamping system for automation**

- can be directly integrated into pallets – ideal for use in the GRESSEL workpiece storage
- centric multiple clamping on base plates or tombstones
- low cost solution for pallet storage
- adaptable for various supplementary zero-point clamping systems

# Systemübersicht System overview

- 1 Komplett gekapselt**
- Schutz vor Verschmutzung
  - unempfindlich gegen Späne
  - hohe Funktionsicherheit
- Completely encapsulated**
- protection against contamination
  - resistant to chips
  - high functional reliability

- 2 Spannungsbereichseinstellung**
- C1 40 mit Drehmomentschlüssel SW 7
  - C1 65 mit Drehmomentschlüssel SW 12
- Clamping range adjustment**
- C1 40 with SW 7 torque wrench
  - C1 65 with SW 12 torque wrench

- 3 Backen Schnellwechsel**
- Backenwechsel in Sekunden
  - einfaches Handling
  - mehrere unterschiedliche Aufsatzbacken
- Quick jaw change**
- jaw change in seconds
  - easy handling
  - several different top jaws

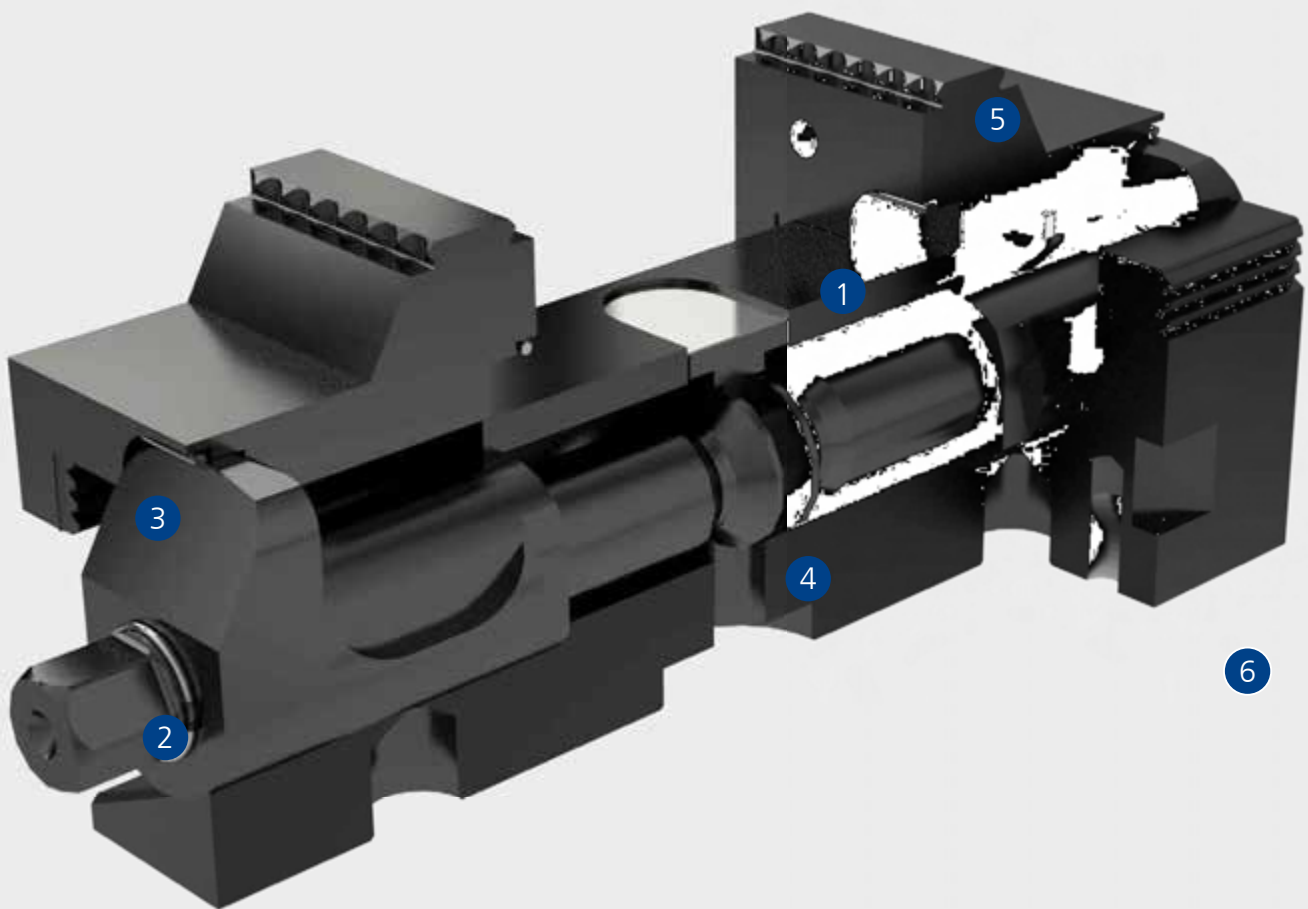

- 4 Zentrierungseinstellung**
- Das Zentrum kann jederzeit ganz einfach und schnell neu eingestellt werden
- Centre adjustment**
- the centre can be easily and quickly readjusted

- 5 1. + 2. Seiten Bearbeitung**
- Wendebacken grip für Erstseitenbearbeitung
  - Präzisionsausführung mit überschleiften Backen im gespannten Zustand für Zweitseitenbearbeitung
  - optimaler Zugang bei 5-Achsen-Bearbeitung
- Machining sides 1 + 2**
- reversible grip jaws for 1<sup>st</sup> side machining
  - precision version with ground jaws for 2<sup>nd</sup> side machining
  - optimum access for 5-axis machining

- 6 Kompakte Ausführung**
- geeignet für 4. + 5. Achse
  - C1 direkt in Palette integriert z. B. für den Einsatz im GRESSEL Werkstückspeicher
- Compact design**
- suitable for 4<sup>th</sup> and 5<sup>th</sup> axis
  - C1 integrated directly in pallet, e.g. for use in the GRESSEL workpiece storage

# Baukasten Construction kit



**C1 grip** · grip  
Seite · page 258

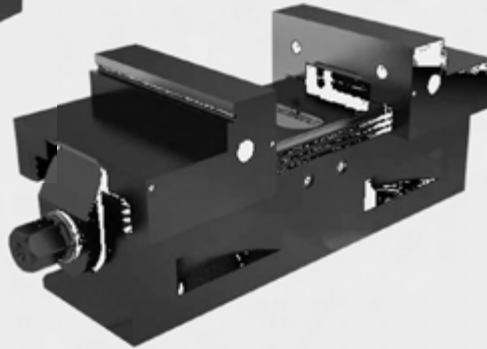

**C1 Präzision** · precision  
Seite · page 259



**C1 grip**  
Wendebacken grip  
reversible grip jaw



**C1 grip**  
Wendebacken grip  
reversible grip jaw

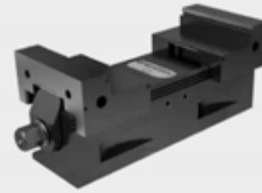

**C1 Präzision** · precision  
Backen glatt überschleiffen im gespannten  
Zustand  
jaws ground smooth in clamped position



**C1 Präzision** · precision  
Backen glatt überschleiffen im gespannten  
Zustand  
jaws ground smooth in clamped position



**C1**  
weiche Stahlbacken  
soft steel jaws



**C1 65-IP-WSP**  
IP Palette für GRESSEL Werkstückspeicher  
IP pallet for GRESSEL workpiece storage



**C1 65-IP**  
Palette Wendebacken grip für marktbeglei-  
tende Nullpunkt-Spannsysteme  
Reversible pallet grip jaws for zero point  
clamping systems available on market

## Anwendungen Applications



**C1 65 grip**  
Auf Unterbau  
**C1 65 grip**  
On base support



**C1 65-IP-WSP**  
IP Palette für GRESSEL Werkstückspeicher P60  
**C1 65-IP-WSP**  
IP pallet for GRESSEL P60 workpiece storage



## Anwendungen Applications

∞ C1



### **C1 65 Präzision**

3 Stück auf Zwischenplatte montiert und mit Nullpunkt Spannsystem gredoc rund gespannt

### **C1 65 precision**

3 pieces mounted on an intermediate plate and clamped with gredoc round zero point clamping system



### **C1 40 grip**

Spannpalette 4-fach mit 4 C1 40 grip montiert

### **C1 40 grip**

Clamping pallet 4-fold mounted with 4 C1 40 grip

## Anwendungen Applications

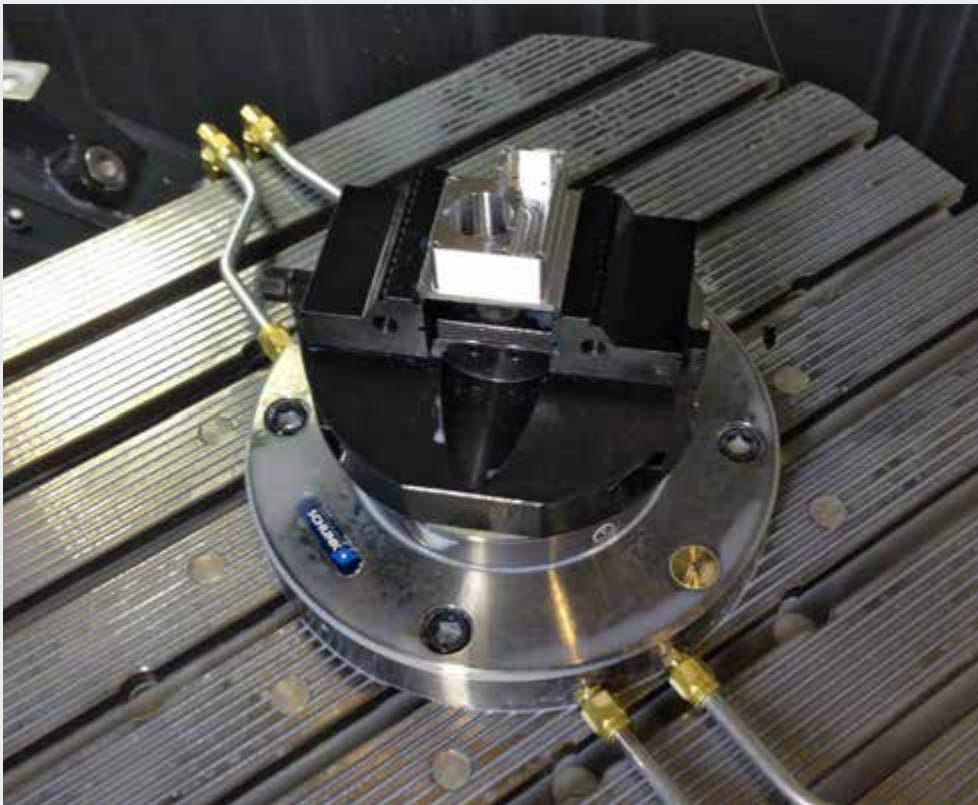

### **C1 65-IP-WSP**

Mit Wendebacken grip auf SCHUNK VERO-S Nullpunkt Spannsystem mit GRESSEL Werkstückspeicher P60

### **C1 65-IP-WSP**

With reversible grip jaws on SCHUNK VERO-S zero point clamping system with GRESSEL workpiece storage P60



### **C1 65-IP-WSP + C2 auf Palette WSP**

Beladungsbeispiel eines GRESSEL Werkstückspeicher P60

### **C1 65-IP-WSP + C2 on pallet WSP**

Loading option of GRESSEL workpiece storage P60

# Anwendungen Applications

∞ C1



**C1 40**  
C1 40 mit Wendebacken grip in einer Häberle Automation an einer FANUC Robodrill Maschine  
**C1 40**  
C1 40 with reversible jaw in a Häberle automation on a FANUC Robodrill machine



**C1 40**  
Mit Wendebacken grip auf Paletten einer Häberle Automation an einer FANUC Robodrill Maschine  
**C1 40**  
With reversible grip jaws on palletized with Häberle automation on a FANUC Robodrill machine



# Standard Schnittstelle Standard interface

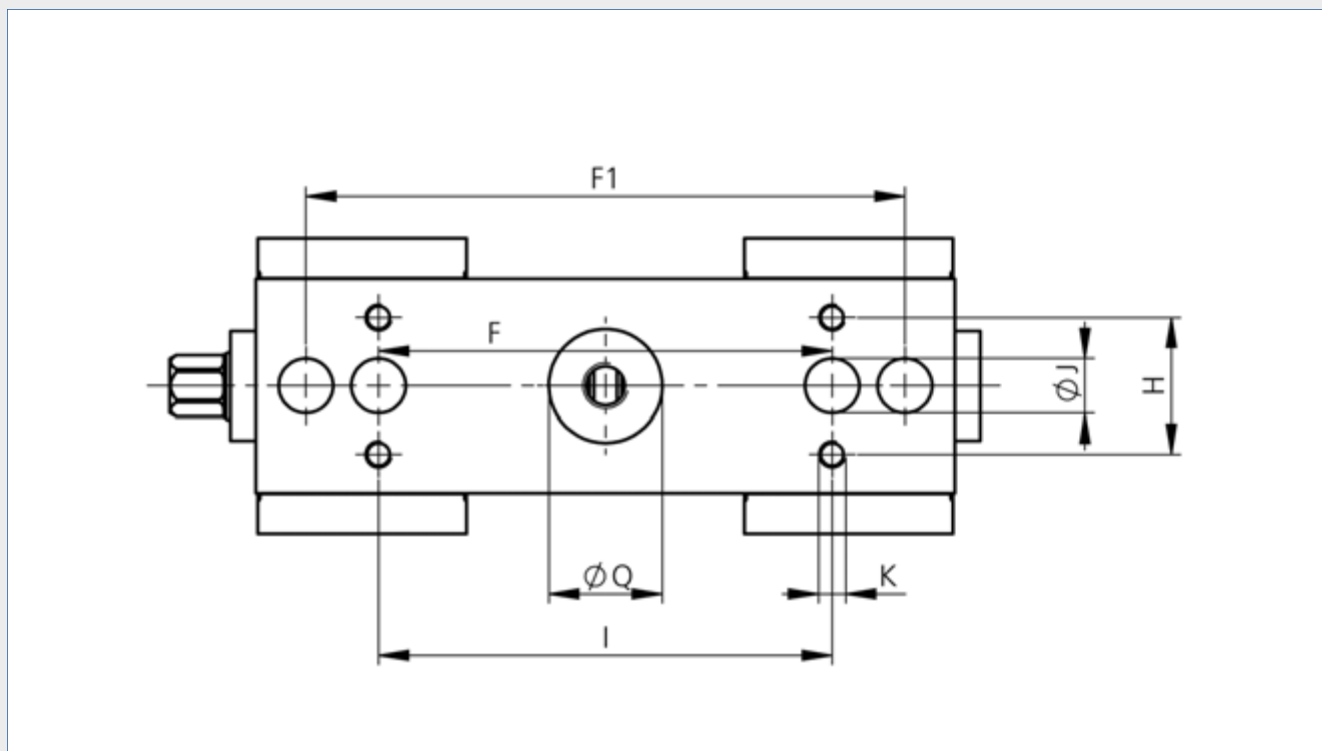

Masse (mm) Dimensions (mm)

Typ	Type	F <sub>±0.015</sub>	F1 <sub>±0.015</sub>	I	øJ <sub>H7</sub>	K	øQ <sub>H7</sub>
C1	40	60	--	60	8	M6	-
C1	65	100	132	100	12	M6	25

# Technische Informationen

## 1. Funktionsprinzip Zentrischspanner C1

Die Zentrischspanner C1 40 und C1 65 sind mechanische Direktspanner. Der Antrieb erfolgt über ein komplett abgedichtetes Gewinde. Der Kraftaufbau erfolgt direkt, ohne Kraftverstärker und ist linear. Die Spannkraft ist abhängig vom Drehmoment. Der Spannungsbereich richtet sich nach dem verwendeten Backensortiment und reicht von 3 bis max. 73 mm (C1 40) und von 0 bis max. 123 mm (C1 65).

## 2. Spannkraften Zentrischspanner C1

Baugröße Assembly size	max. Anzugs-Drehmoment max. torque	max. Spannkraft max. clamping force
C1 40	20 Nm	7 kN

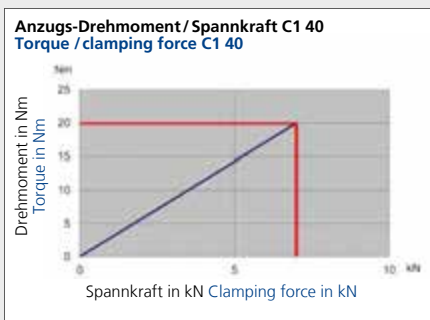

# Technical information

## 1. Functional principle centric vice C1

The centric vices C1 40 and C1 65 are mechanical direct vices. The drive takes place with a completely sealed thread. The clamping force is applied directly without force amplification and is linear. The clamping force depends on the torque. The clamping range depends on the size of jaws used, from 3 to max. 73 mm (C1 40) and from 0 to max. 123 mm (C1 65).

## 2. Clamping forces centric vice C1

Baugröße Assembly size	max. Anzugs-Drehmoment max. torque	max. Spannkraft max. clamping force
C1 65	50 Nm	15 kN

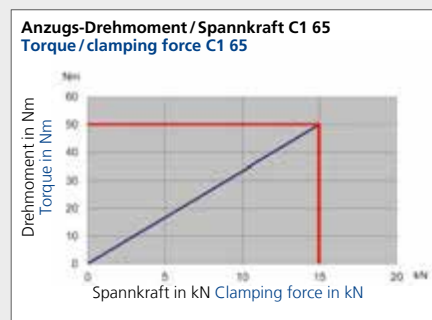

## 3. Aufspannen / Ausrichten

In der Grundausführung sind 2x  $\varnothing 8H7$  (C1 40), 2x  $\varnothing 12H7$  (C1 65) Präzisionsbohrungen vorhanden, mit denen die C1 auf Rasterplatten sowie T-Nuten-Tischen positioniert werden können. Die C1 werden von oben mit 4 Schrauben M12x35 und 4 Spannpratzen befestigt.

Alternativ können die Zentrischspanner C1 auch von unten mit 4 Schrauben M6 x 12 (C1 40) und M6 x 16 (C1 65) befestigt werden.

Beim C1 65 ist der Grundkörper mit einer Schnittstelle ausgestattet, die es ermöglicht, den Aufnahmebolzen für das mechanische Nullpunkt-Spannsystem gredoc zu befestigen. Der C1 40 braucht dafür eine Zwischenplatte.

Die Zentrischspanner C1 können werkseitig auch mit kundenspezifischen Positionier- und Befestigungsbohrungen ausgeführt werden.

Adaptierbar für verschiedene marktbegleitende Nullpunkt-Spannsysteme.

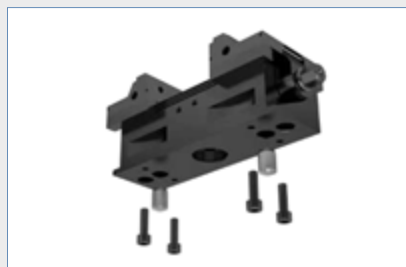

## 3. Clamping / alignment

In the basic version, 2x  $\varnothing 8H7$  (C1 40), 2x  $\varnothing 12H7$  (C1 65) precision holes are provided which can be used to position the C1 units on grid plates and T-slot tables. The C1 units are mounted from the top using 4 screws M12x35 and 4 clamping claws.

Alternatively, the C1 centric vices can also be attached from below using 4 screws M6 x 12 (C1 40) and screws M6 x 17 (C1 65).

The basic body of the C1 65 is equipped with an interface for attaching the holding bolt for the mechanical gredoc zero-point clamping system. The C1 40 requires an intermediate plate for this purpose.

It is also possible to supply the C1 centric vices ex factory with customer-specific positioning and attachment holes.

The units can be adapted to various supplementary zero-point clamping systems.

## Technische Informationen

## Technical information

### 4. Backenschnellwechsel Zentrischspanner C1

### 4. Quick jaw change centric vice C1

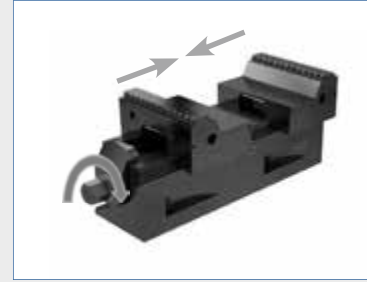
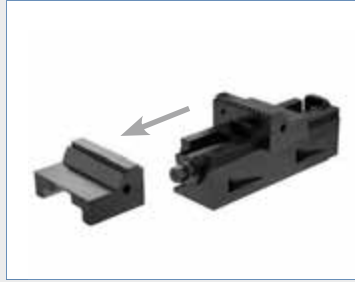

### 5. Kontur-Einfräsung weiche Backen C1

### 5. Cutting contours into soft jaws C1

Die weichen Stahlbacken müssen für das Ausfräsen der Kontur im C1 gespannt werden. Legen Sie für die geplante Backenöffnung ein Distanzstück ein. Spannen Sie die Hauptspindel mit dem geplanten Drehmoment und fräsen Sie die Spannkontur aus.



In order to cut a contour the soft steel jaws have to be clamped into the C1 vice. Place a space holder into the planned jaw opening. Tighten the main spindle with the planned torque and proceed to cut the clamping contour.

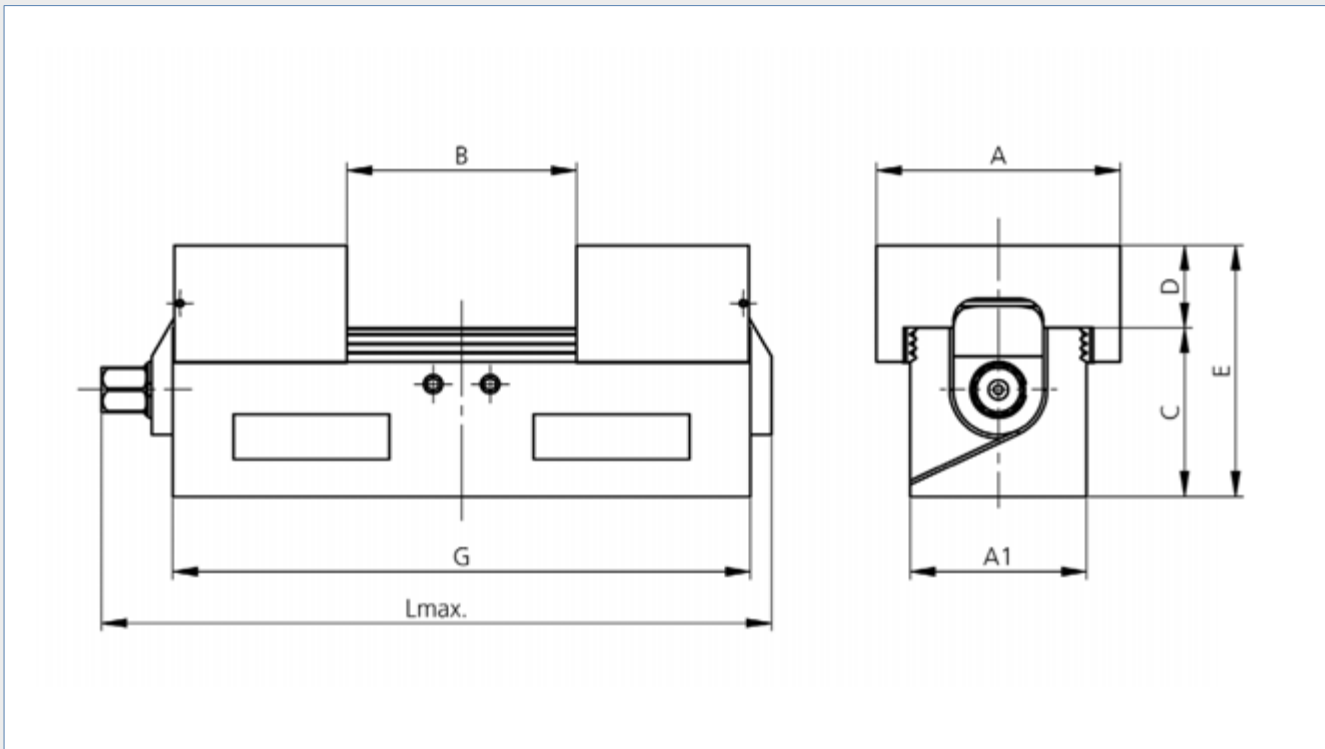

Masse (mm) Dimensions (mm)

Typ Type	A	A1	B	C	D	E	G	L <sub>max.</sub>
C1 40	40	30	0-34	30	16	46	89	106
C1 65	65	47	0-60	45	22	67	154	178,5

## C1 grip

mit Wendebacken grip  
with reversible grip jaw



Typ Type	Beschreibung Description	Backenbreite Jaw width	Spannkraft Clamp. force	Gewicht Weight	Lieferumfang Delivery details	Bestell-Nr. Order No.
		mm	kN	kg		
C1 40 grip	Zentrischspanner mit Wendebacken grip Centric vice with reversible grip jaw	40	max. 7	0.8	inkl. 2 Stifte $\varnothing 8m6$ und Öffner für Backenschnellwechsel incl. 2 pins $\varnothing 8m6$ and changing tool for quick jaw change	CGM.040.001.01
C1 65 grip	Zentrischspanner mit Wendebacken grip Centric vice with reversible grip jaw	65	max. 15	2.9	inkl. 2 Stifte $\varnothing 12m6$ , Schrauben für Ausatzbacken und Öffner für Backenschnellwechsel incl. 2 pins $\varnothing 12m6$ , screws for top jaw and changing tool for quick jaw change	CGM.065.001.01

Masse (mm) Dimensions (mm)

Typ Type	A	A1	B	B1	B2	C	D	E	F	G	L <sub>max.</sub>
C1 40 grip	40	30	0-34	4-38	37-71	30	16	46	2	89	106
C1 65 grip	65	47	0-60	6-65	64-123	45	22	67	3	154	178,5

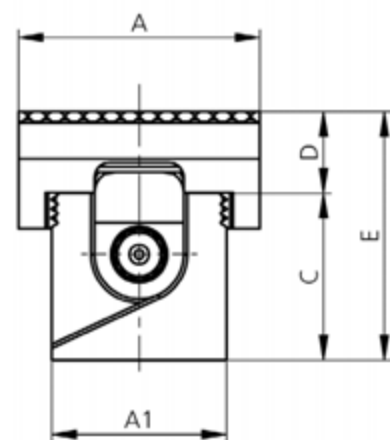
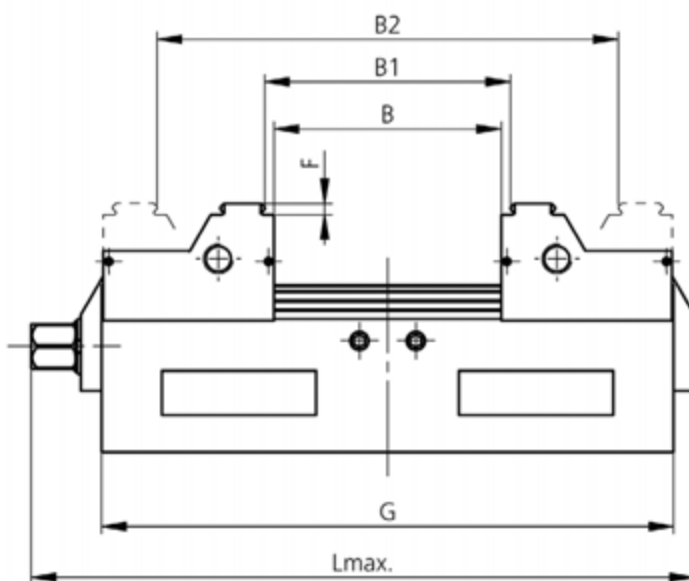



## C1 Präzision · Precision

mit Wendeböcken Stufen geschliffen  
with ground reversible step jaws



Typ Type	Beschreibung Description	Backenbreite Jaw width	Spannkraft Clamp. force	Gewicht Weight	Lieferumfang Delivery details	Bestell-Nr. Order No.
		mm	kN	kg		
<b>C1 40</b> Präzision · Precision	Zentrischspanner Backen im gespannten Zustand überschliffen Centric vice, ground jaws in the clamped position	40	max. 7	0.8	inkl. 2 Stifte ø8m6 und Öffner für Backenschnellwechsel incl. 2 pins ø8m6 and changing tool for quick jaw change	CGM.040.002.01
<b>C1 65</b> Präzision · Precision	Zentrischspanner Backen im gespannten Zustand überschliffen Centric vice, ground jaws in the clamped position	65	max. 15	2.9	inkl. 2 Stifte ø12m6, Schrauben für Aufsatzbacken und Öffner für Backenschnellwechsel incl. 2 pins ø12m6, screws for top jaws and changing tool for quick jaw change	CGM.065.002.01

Masse (mm) Dimensions (mm)

Typ Type	A	A1	B	B1	C	D	E	F	G	L <sub>max.</sub>
<b>C1 40</b> Präzision · Precision	40	30	0-34	33-67	30	16	46	5	89	106
<b>C1 65</b> Präzision · Precision	65	47	0-60	61-120	45	22	67	5	154	178,5

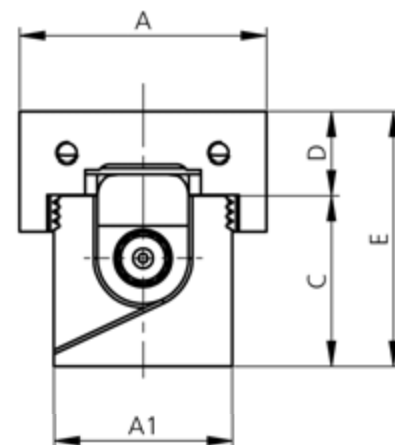
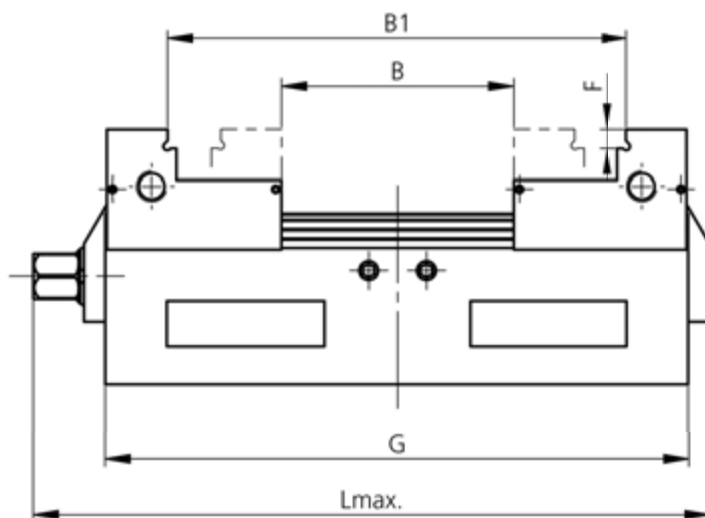

## C1 40/65

ohne Backen  
without jaws



Typ Type	Beschreibung Description	Backenbreite Jaw width	Spannkraft Clamp. force	Gewicht Weight	Lieferumfang Delivery details	Bestell-Nr. Order No.
		mm	kN	kg		
C1 40	Zentrischspanner ohne Backen Centric vice, without jaws	40	max. 7	0.6	inkl. 2 Stifte $\varnothing 8m6$ und Öffner für Backenschnellwechsel incl. 2 pins $\varnothing 8m6$ and changing tool for quick jaw change	CGM.040.003.01
C1 65	Zentrischspanner ohne Backen Centric vice, without jaws	65	max. 15	2.1	inkl. 2 Stifte $\varnothing 12m6$ und Öffner für Backenschnellwechsel incl. 2 pins $\varnothing 12m6$ and changing tool for quick jaw change	CGM.065.003.01

Masse (mm) Dimensions (mm)

Typ Type	A1	C	G	L <sub>max.</sub>
C1 40 ohne Backen * without jaws	30	30	89	106
C1 65 ohne Backen * without jaws	47	45	154	178,5

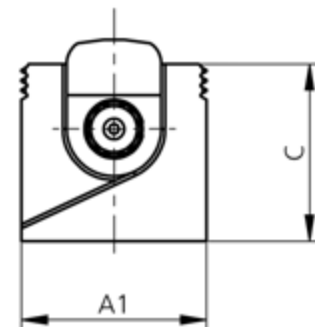
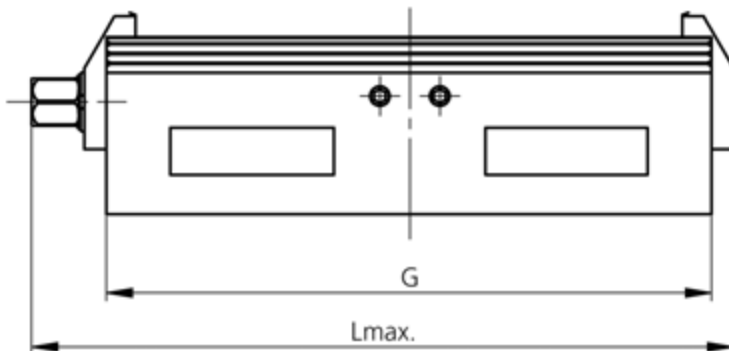

## C1 65-IP-WSP

**IP Palette für GRESSEL Werkstückspeicher**  
**IP pallet for GRESSEL workpiece storage**



Typ Type	Beschreibung Description	Backenbreite Jaw width	Spannkraft Clamp. force	Gewicht Weight	Lieferumfang Delivery details	Bestell-Nr. Order No.
		mm	kN	kg		
C1 65-IP-WSP	Zentrischspanner mit Wendebacken grip Centric vice with reversible grip jaw	65	max. 15	5.7	Spannbolzen, 2 Stifte $\phi 12m6$ , Schrauben für Aufsatzbacken, Öffner für Backenschnellwechsel Clamping pins, 2 pins $\phi 12m6$ screws for top jaws, changing tool for quick jaw change	CGM.065.021.01
C1 65-IP-WSP	Zentrischspanner ohne Backen Centric vice without jaws	65	max. 15	5.0	Spannbolzen, 2 Stifte $\phi 12m6$ , Öffner für Backenschnellwechsel, ohne Systembacken Clamping pins, 2 pins $\phi 12m6$ changing tool for quick jaw change without system jaws	CGM.065.023.01

Masse (mm) Dimensions (mm)

Typ Type	A	B	B1	B2	C	D	E	F	G	L <sub>max.</sub>	$\phi TK$
C1 65-IP-WSP	65	0-60	6-65	64-123	55	22	77	3	150	178.5	118

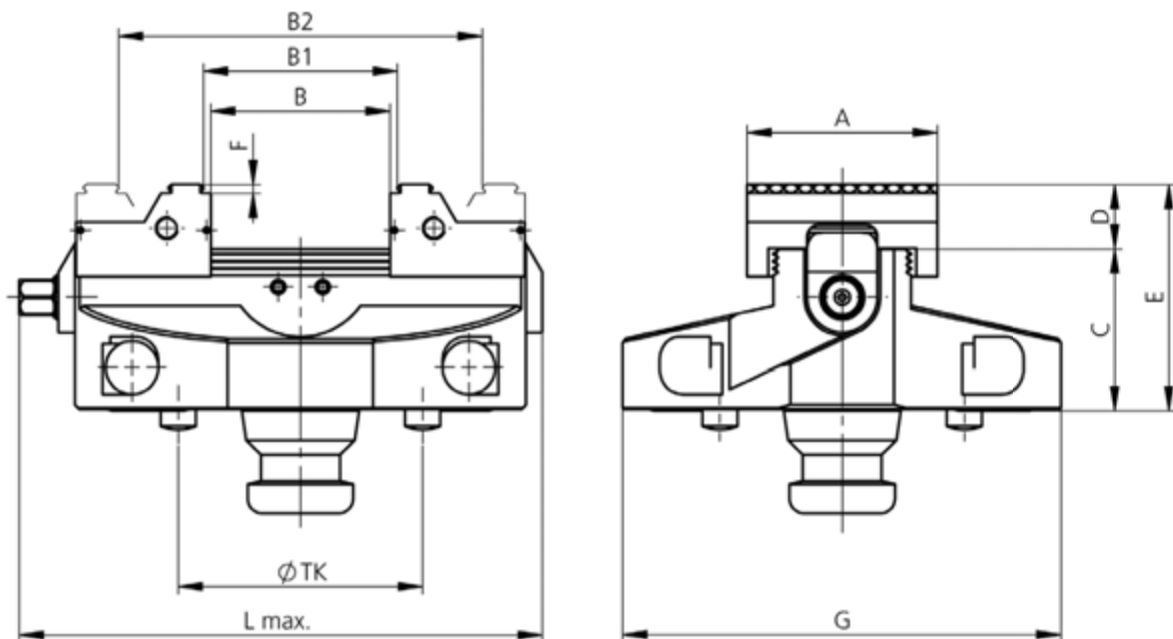

## C1 65-IP-WSP

**IP Palette für GRESSEL Werkstückspeicher**  
**IP pallet for GRESSEL workpiece storage**



Typ Type	Beschreibung Description	Backenbreite Jaw width	Spannkraft Clamp. force	Gewicht Weight	Lieferumfang Delivery details	Bestell-Nr. Order No.
		mm	kN	kg		
C1 65-IP-WSP	Zentrischspanner mit geschliffenen Wendebacken Centric vice with ground reversible jaws	65	max. 15	5.7	Spannbolzen, 2 Stifte $\phi 12m6$ , Schrauben für Aufsatzbacken, Öffner für Backenschnellwechsel Clamping pins, 2 pins $\phi 12m6$ screws for top jaws, changing tool for quick jaw change	CGM.065.022.01

Masse (mm) Dimensions (mm)

Typ Type	A	B	B1	C	D	E	F	G	L <sub>max.</sub>	$\phi TK$
C1 65-IP-WSP	65	0-60	61-120	55	22	77	5	150	178	118

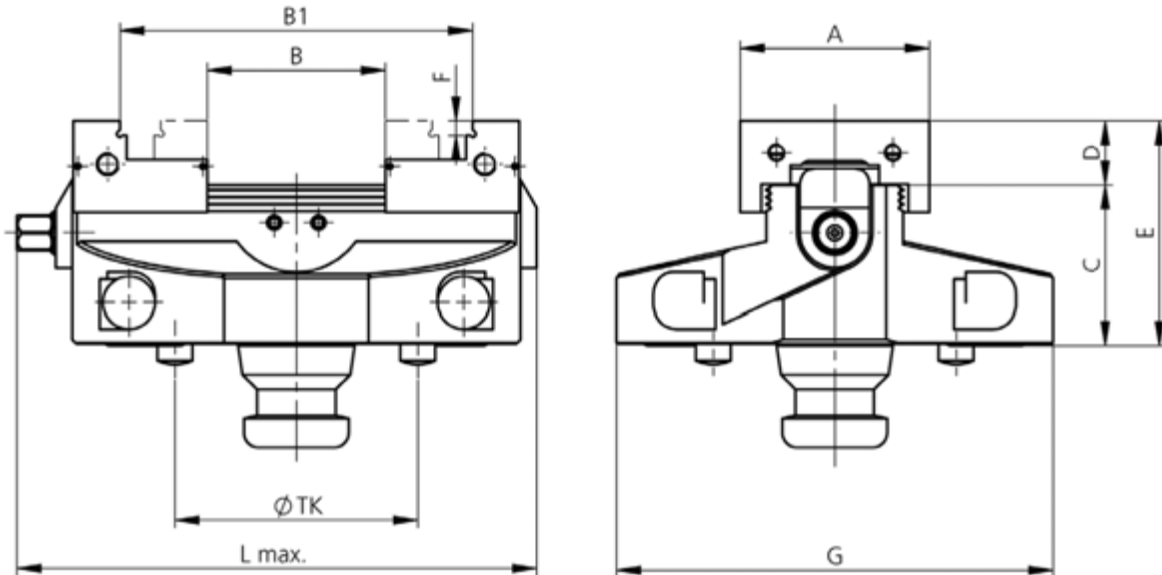



## C1 65-IP

passend auf Lang und Zero Clamp Nullpunkt-Spannsystem  
suitable for Lang and Zero Clamp zero point clamping system



Typ Type	Beschreibung Description	Backenbreite Jaw width	Spannkraft Clamp. force	Gewicht Weight	Lieferumfang Delivery details	Bestell-Nr. Order No.
		mm	kN	kg		
C1 65-IP Lang + Zero Clamp	Zentrischspanner mit Wendebacken grip Centric vice with reversible grip jaw	65	max. 15	5.7	inkl. Schrauben für Aufsatzbacken und Öffner für Backenschnell- wechsel incl. screws for top jaws and changing tool for quick jaw change	CGM.065.031.01
C1 65-IP Lang + Zero Clamp	Zentrischspanner ohne Backen Centric vice without jaws	65	max. 15	5.7	inkl. Öffner für Backenschnell- wechsel incl. changing tool for quick jaw change	CGM.065.033.01

Masse (mm) Dimensions (mm)

Typ Type	A	B	B1	B2	C	D	E	F	G	L <sub>max.</sub>
C1 65-IP Lang + Zero Clamp	65	0-60	6-65	64-123	55	22	77	3	125	178.5

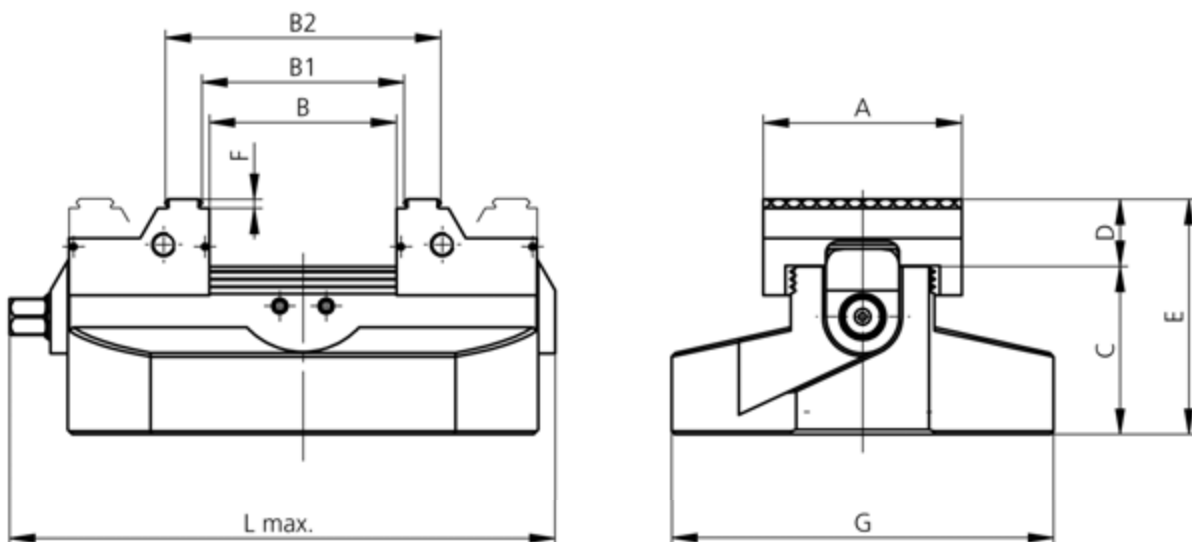

Lang Quick Point 52x52  
Lang Quick Point 52x52



Lang Quick Point 96x96  
Lang Quick Point 96x96



Zero Clamp  
Zero Clamp

# C1 65-IP

passend auf Lang und Zero Clamp Nullpunkt-Spannsystem  
suitable for Lang and Zero Clamp zero point clamping system



Typ Type	Beschreibung Description	Backenbreite Jaw width	Spannkraft Clamp. force	Gewicht Weight	Lieferumfang Delivery details	Bestell-Nr. Order No.
		mm	kN	kg		
C1 65-IP Lang + Zero Clamp	Zentrischspanner mit geschliffenen Wendebcken Centric vice with ground reversible jaws	65	max. 15	5.7	inkl. Schrauben für Aufsatzbacken und Öffner für Backenschnell- wechsel incl. screws for top jaws and changing tool for quick jaw change	CGM.065.032.01

Masse (mm) Dimensions (mm)

Typ Type	A	B	B1	C	D	E	F	G	L <sub>max.</sub>
C1 65-IP Lang + Zero Clamp	65	0-60	61-65	55	22	77	5	125	178.5

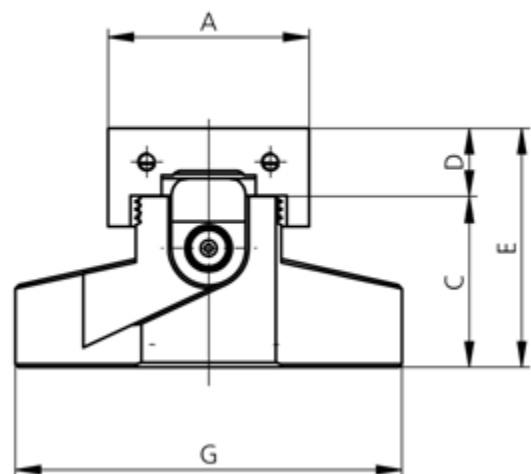
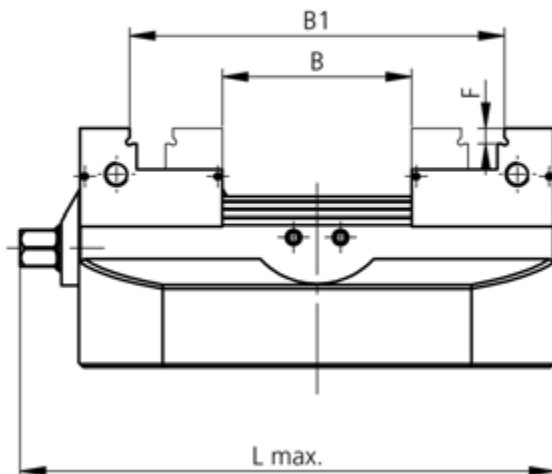

Lang Quick Point 52x52  
Lang Quick Point 52x52



Lang Quick Point 96x96  
Lang Quick Point 96x96



Zero Clamp  
Zero Clamp

## C1 65 grip

mit Mittelbacke  
with central jaw



Typ Type	Beschreibung Description	Backenbreite Jaw width	Spannkraft Clamp. force	Gewicht Weight	Lieferumfang Delivery details	Bestell-Nr. Order No.
		mm	kN	kg		
C1 65 grip	Zentrischspanner mit Wendebacken grip Centric vice with reversible grip jaw	65	max. 15	2.9	inkl. 2 Stifte ø12m6, Schrauben für Aufsatzbacken und Öffner für Backenschnellwechsel incl. 2 pins ø12m6, screws for top jaws and changing tool for quick jaw change	CGM.065.001.01
Systembacke System jaw	Mittelbacke grip Central grip jaw	65		0.2	Mittelbacke grip inkl. Schrauben Central grip jaw incl. screws	CGA.065.008.01

Das Spannmittel und die Systembacken müssen für diese Version jeweils separat zusammengestellt werden.  
The clamping device and the system jaws have to be separately assembled for this version.

Masse (mm) Dimensions (mm)

Typ Type	A	A1	B	B1	C	D	E	F	G	L <sub>max.</sub>
C1 65 grip	65	47	6-26	35-55	45	22	67	3	154	178,5

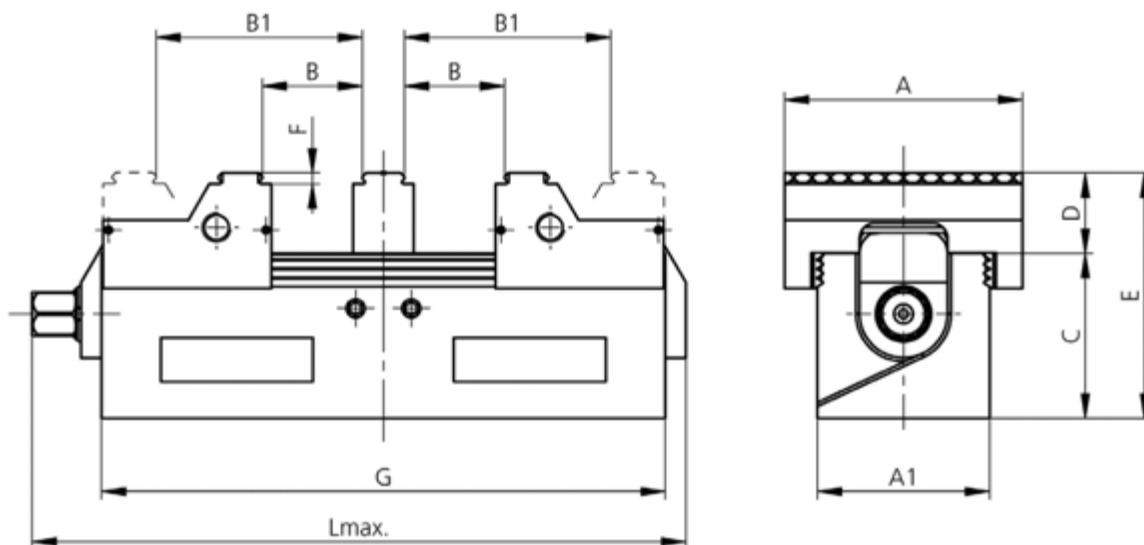

# C1 65

mit Mittelbacke weich  
with central soft jaw



Typ Type	Beschreibung Description	Backenbreite Jaw width	Spannkraft Clamp. force	Gewicht Weight	Lieferumfang Delivery details	Bestell-Nr. Order No.
		mm	kN	kg		
C1 65	Zentrischspanner ohne Backen Centric vice, without jaws	65	max. 15	2.1	Inkl. 2 Stifte Ø12m6 und Öffner für Backenschnellwechsel Incl. 2 pins Ø12m6 and changing tool for quick jaw change	CGM.065.003.01
Systembacke System jaw	Weiche Stahlbacke (pro Spanner 2 Stk.) Soft steel jaw (per vice, 2 pcs.)	65		0.3	Weiche Stahlbacke Soft steel jaw	CGA.065.007.01
Systembacke System jaw	Mittelbacke weich Central soft jaw	65		0.5	Mittelbacke weich inkl. Schrauben Central soft jaw incl. screws	CGZ.065.009.01

Das Spannmittel und die Systembacken müssen für diese Version jeweils separat zusammengestellt werden.  
The clamping device and the system jaws have to be separately assembled for this version.

Masse (mm) Dimensions (mm)

Typ Type	A	A1	B	C	D	E	F	G	H	I	J	K	L <sub>max.</sub>
C1 65	65	47	10	45	22	67	40	154	32	17	12	16	178.5

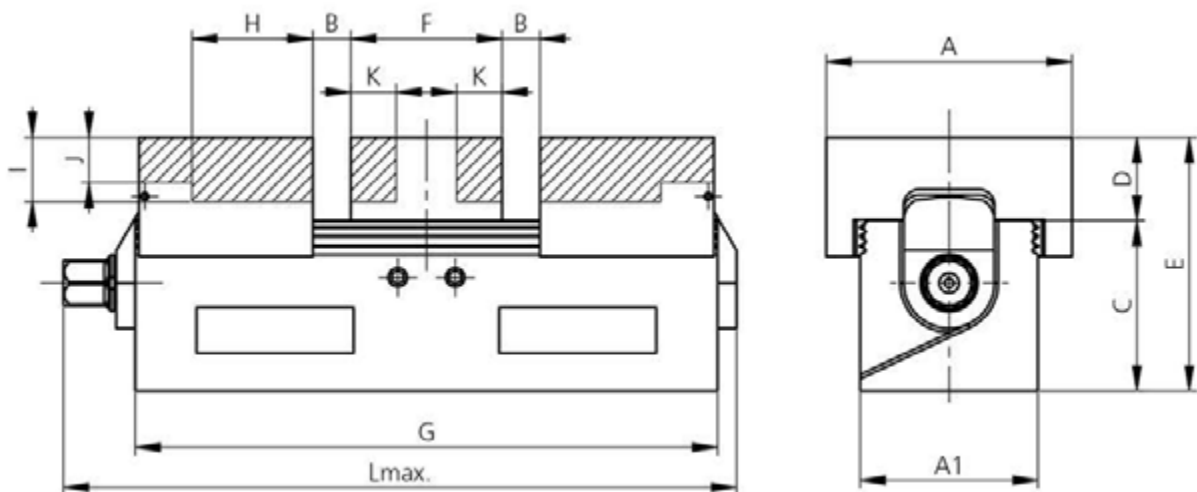



## C1 40-IP-ITS 50

für Erowa ITS 50  
for Erowa ITS 50



Typ Type	Beschreibung Description	Backenbreite Jaw width	Spannkraft Clamp. force	Gewicht Weight	Lieferumfang Delivery details	Bestell-Nr. Order No.
		mm	kN	kg		
C1 40-IP-ITS 50	Zentrischspanner mit Wendebacken grip für Erowa ITS 50 Centric vice with reversible grip jaw for Erowa ITS 50	40	max. 7	1.25	Spannzapfen, Öffner für Backen- schnellwechsel Clamping spigots, opener for quick jaw change	CGM.040.041.01

Masse (mm) Dimensions (mm)

Typ Type	A	B	B1	B2	C	D	E	F	G	L <sub>max.</sub>
C1 40-IP-ITS 50	40	0-34	5-38	37-71	41.2	16	57.2	2	72	106.7

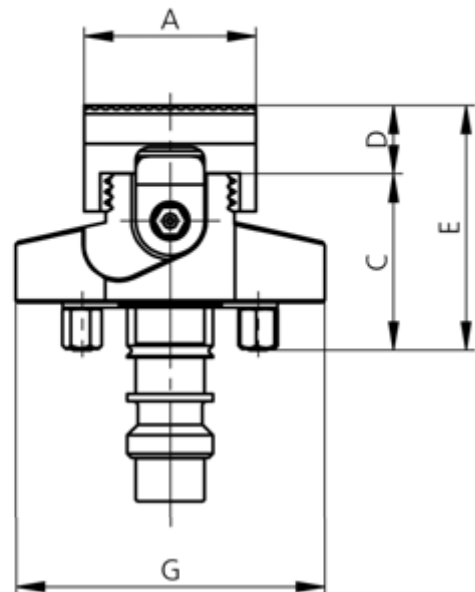
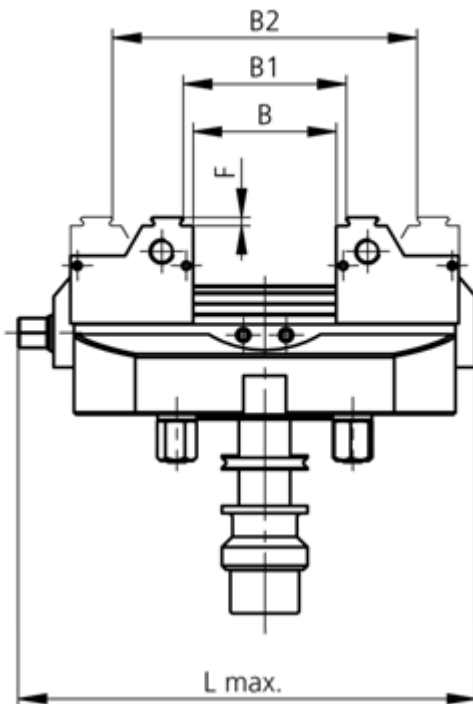

# C1 65-IP-ITS 148

für Erowa ITS 148  
for Erowa ITS 148



Typ Type	Beschreibung Description	Backenbreite Jaw width	Spannkraft Clamp. force	Gewicht Weight	Lieferumfang Delivery details	Bestell-Nr. Order No.
		mm	kN	kg		
C1 65-IP-ITS 148	Zentrischspanner mit Wendebacken grip für Erowa ITS 148 Centric vice with reversible grip jaw for Erowa ITS148	65	max. 15	6.0	Spannzapfen, Schrauben für Aufsatzbacken, Öffner für Backenschnellwechsel Clamping spigots, screws for top jaw, changing tool for quick jaw change	CGM.065.041.01

Masse (mm) Dimensions (mm)

Typ Type	A	B	B1	B2	C	D	E	F	øG	L <sub>max.</sub>
C1 65-IP-ITS 148	65	0-60	6-65	64-123	68	22	90	3	148	178.5

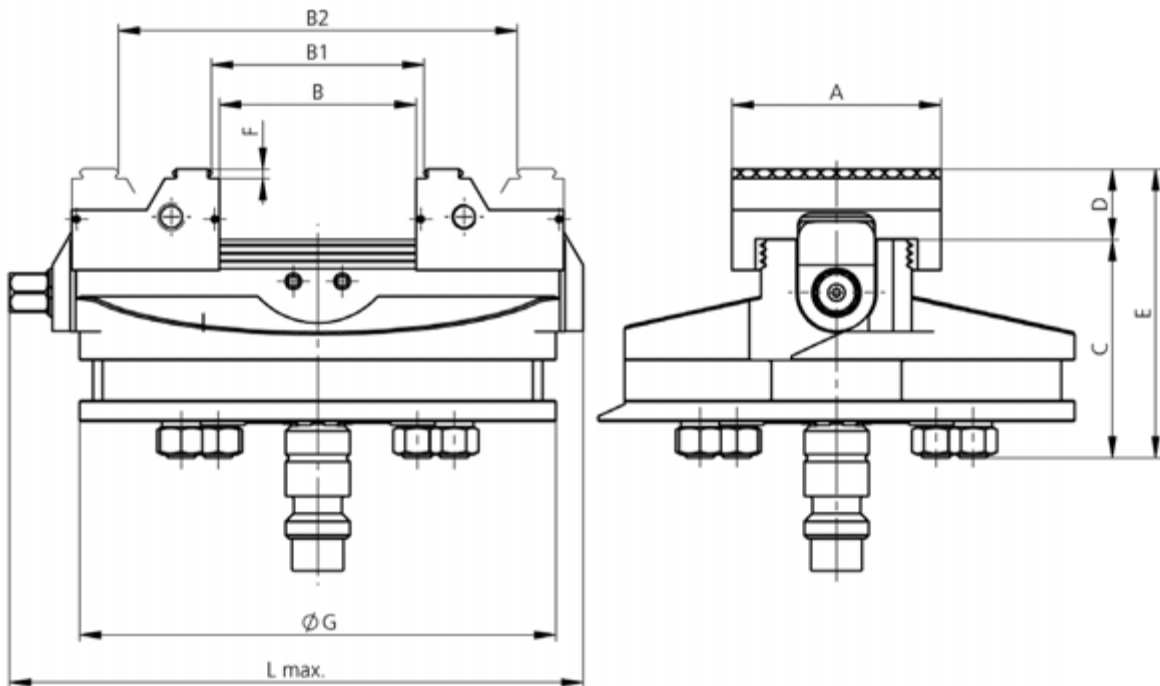

## C1 65-IP-MTS

für Erowa MTS  
for Erowa MTS



Typ Type	Beschreibung Description	Backenbreite Jaw width	Spannkraft Clamp. force	Gewicht Weight	Lieferumfang Delivery details	Bestell-Nr. Order No.
		mm	kN	kg		
C1 65-IP-MTS	Zentrischspanner mit Wendebacken grip für Erowa MTS Centric vice with reversible jaw grip for Erowa MTS	65	max. 15	6.3	Spannzapfen und Zentrierplatte, Öffner für Backenschnellwechsel Clamping spigots and centring, changing tool for quick jaw change	CGM.065.051.01

Masse (mm) Dimensions (mm)

Typ Type	A	B	B1	B2	C	D	E	F	øG	L <sub>max.</sub>
C1 65-IP-MTS	65	0-60	60-65	64-123	68	22	90	3	ø148.3	178.5

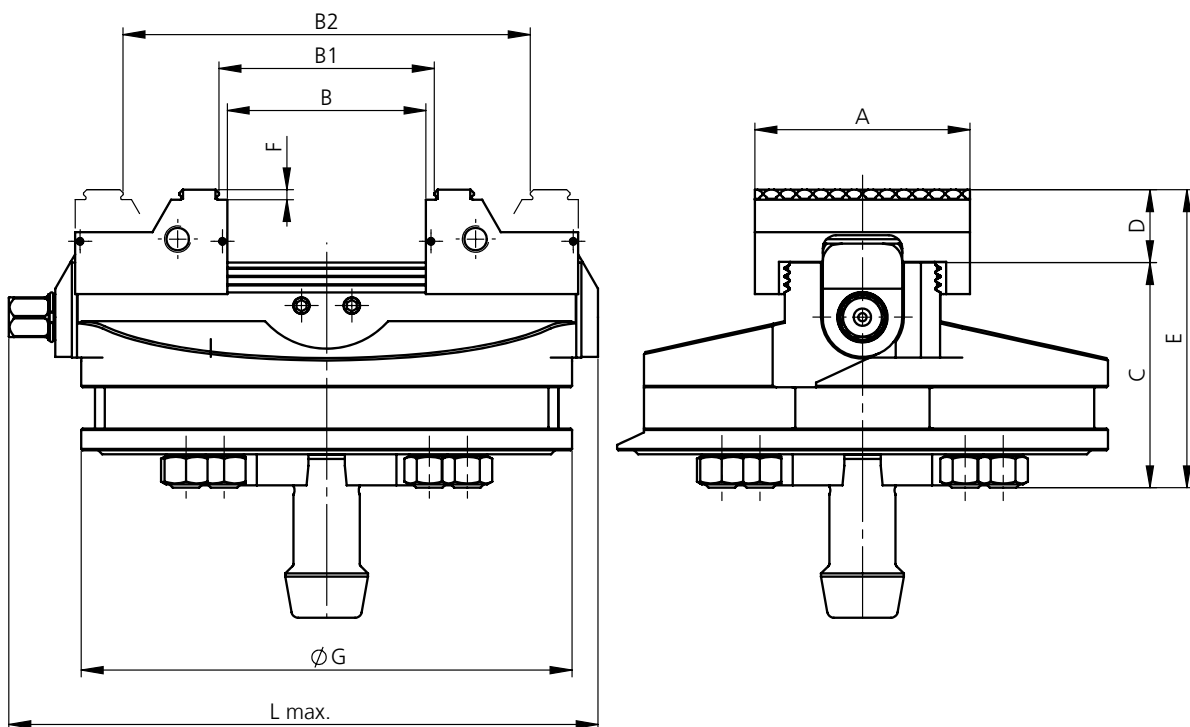

# C1 65-IP-MTS

für Erowa MTS  
for Erowa MTS



Typ Type	Beschreibung Description	Backenbreite Jaw width	Spannkraft Clamp. force	Gewicht Weight	Lieferumfang Delivery details	Bestell-Nr. Order No.
		mm	kN	kg		
C1 65-IP-MTS	Zentrischspanner mit geschliffenen Wendebacken für Erowa MTS Centric vice with ground reversible jaws for Erowa MTS	65	max. 15	6.3	Spannzapfen und Zentrierplatte, Öffner für Backenschnellwechsel Clamping spigots and centring, changing tool for quick jaw change	CGM.065.052.01

Masse (mm) Dimensions (mm)

Typ Type	A	B	B1	C	D	E	F	øG	L <sub>max.</sub>
C1 65-IP-MTS	65	0-60	60-120	68	22	90	5	148.3	178.5

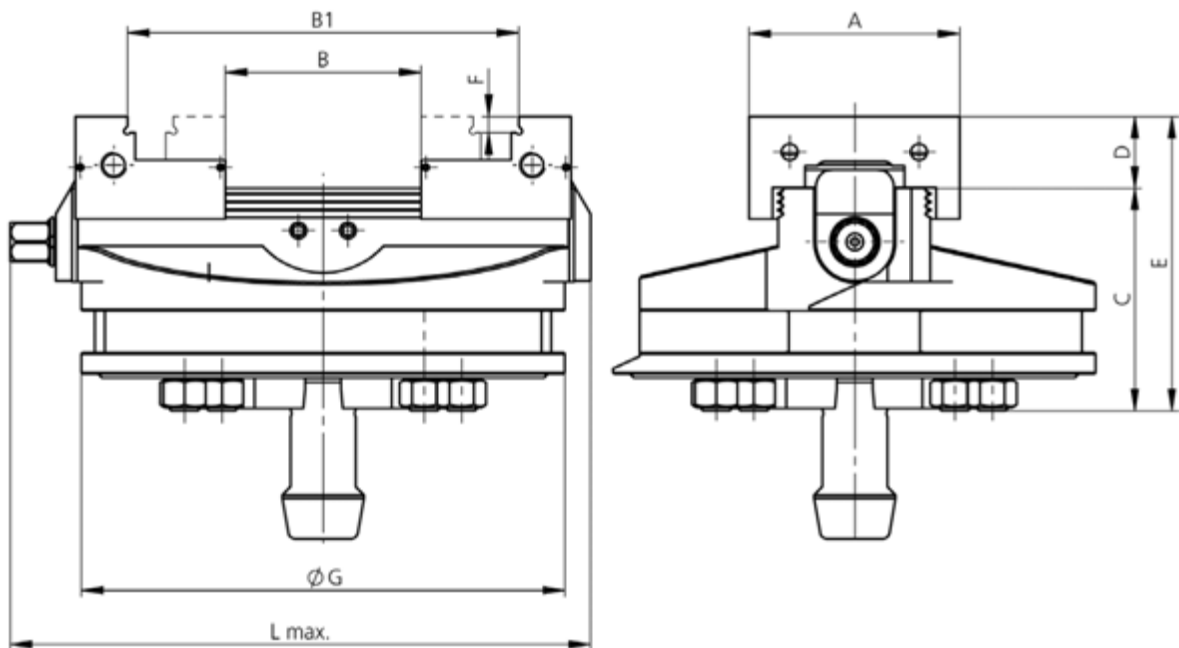



# C1 65-IP-ITS 148

für Erowa ITS 148  
for Erowa ITS 148





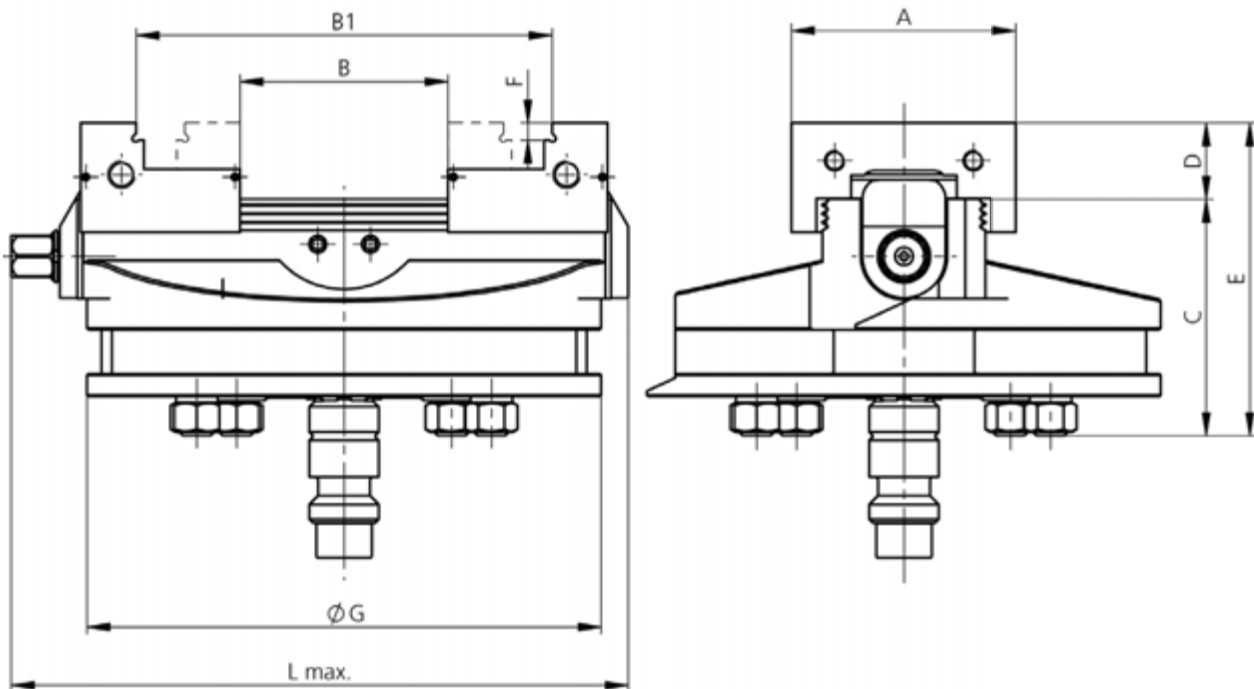

Typ Type	Beschreibung Description	Backenbreite Jaw width	Spannkraft Clamp. force	Gewicht Weight	Lieferumfang Delivery details	Bestell-Nr. Order No.
		mm	kN	kg		
C1 65-IP-ITS 148	Zentrischspanner mit geschliffenen Wendebacken für Erowa ITS 148 Centric vice with ground reversible jaws for Erowa ITS 148	65	max. 15	6.0	Spannzapfen, Schrauben für Aufsatzbacken, Öffner für Backenschnellwechsel Clamping spigots, screws for top jaw, opener for quick jaw change	CGM.065.042.01

Masse (mm) Dimensions (mm)



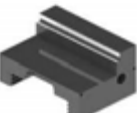





Typ Type	A	B	B1	C	D	E	F	ØG	L <sub>max.</sub>
C1 65-IP-ITS 148	65	0-60	60-120	68	22	90	5	148	178.5



## C1 Systembacken · System jaws

	Bezeichnung Designation	passend zu Typ suitable for type	Bestell-Nr. Order No.
	<b>Wendebacke grip</b> inkl. Schrauben für Aufsatzbacken (C1 65) Einspanntiefe C1 40 = 2 mm, C1 65 = 3 mm (1 Stk.) <b>Reversiblegrip jaw</b> incl. screws for top jaws (C1 65) Clamping depth C1 40 = 2 mm, C1 65 = 3mm (1 pc.)	C1 40	CGA.040.001.01
		C1 65	CGA.065.001.01
	<b>Wendebacke Stufe geschliffen</b> inkl. Schrauben für Aufsatzbacken (C1 65) Einspanntiefe = 5 mm (1 Stk.) <b>Reversible jaws stepped and ground</b> incl. screws for top jaws (C1 65) Clamping depth = 5 mm (1 pc.)	C1 40	CGA.040.002.01
		C1 65	CGA.065.002.01
	<b>Weiche Stahlbacke</b> (1 Stk.) <b>Soft steel jaw</b> (1 pc.)	C1 40	CGA.040.007.01
		C1 65	CGA.065.007.01
	<b>Mittelbacke grip</b> Einspanntiefe 3 mm (1 Stk.) <b>Central grip jaw</b> Clamping depth 3 mm (1 pc.)	C1 65	CGA.065.008.01
	<b>Mittelbacke weich</b> (1 Stk.) <b>Central soft jaw</b> (1 pc.)	C1 65	CGZ.065.009.01

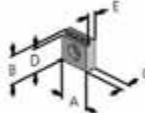
# C1 Aufsatzbacken · Top jaws

	Bezeichnung Designation	Masse (mm) Dimensions (mm)					passend zu Typ suitable for type	Bestell-Nr. Order No.
		A	B	C	D	E		
							C1 65	
	<b>Federblech-Niederzugbacke</b> (1 Stk.) <b>Pull-down jaw with spring-plate</b> (1 pc.)	65	23	10			•	CSA.065.011.01
	<b>Backe geschliffen</b> Höhe = 22 mm (1 Stk.) <b>Ground jaw</b> Height = 22 mm (1 pc.)	65	22	7.7			•	FSA.065.036.11
	<b>Backe grip</b> Höhe = 22 mm (1 Stk.) <b>Grip jaw</b> Height = 22 mm (1 pc.)	65	22	7.8			•	FSA.065.039.01
	<b>Backe weich</b> Höhe = 22 mm (1 Stk.) <b>Soft jaw</b> Height = 22 mm (1 pc.)	65	22	20			•	FSA.065.037.11
	<b>Backe gehauen</b> Höhe = 22 mm (1 Stk.) <b>Serrated jaw</b> Height = 22 mm (1 pc.)	65	22	8			•	FSA.065.035.11
	<b>Universal-Stufenbacke</b> (1 Stk.) <b>Universal stepped jaw</b> (1 pc.)	65	22	8	19	5.5	•	CSA.065.002.11
	<b>Backe grip</b> (1 Stk.) Breite 22 = 65, wendbar <b>Grip jaw</b> (1 pc.) Width 22 = 65, reversible	22	22	8	19	5.5	•	CSA.065.005.11
	<b>Backe grip wendbar</b> Stufe mit 3 mm vertikal, Stufe mit 5 mm horizontal (1 Stk.) <b>Reversible grip jaw</b> Step with 3 mm vertical, Step with 5 mm horizontal (1 pc.)	65	22	8	19	5.5	•	CSA.065.003.11
	<b>Prismabacke geschliffen</b> ø11-22 mm (1 Stk.) <b>Ground prismatic jaw</b> ø11-22 mm (1 pc.)	65	22	20			•	CSA.065.007.11