

Installation And Operation Instructions

**For BLEM Series Emergency LED Drivers
(20 Vdc - 50 Vdc Models)**

IMPORTANT SAFEGUARDS

When using electrical equipment, basic safety precautions should always be followed, including the following:

READ AND FOLLOW ALL SAFETY INSTRUCTIONS:

- 1) *The BLEM series driver is designed for both factory or field installation only when determined to meet the as installed egress requirements as outlined on page 4 of these instructions.*
- 2) *Installation should be performed by qualified personnel only.*
- 3) *Install in accordance with the National Electric Code and applicable local codes.*
- 4) *The BLEM series requires an unswitched AC power source of 120 to 277 volts, 50/60 HZ.*
- 5) *The BLEM series is suitable for use in dry and damp location where ambient temperature is 10 to 55°C.*
- 6) *The BLEM series driver should be mounted in locations and at heights where it will not readily be subjected to tampering by unauthorized personnel.*
- 7) *The BLEM series driver is suitable for use only with LED lamps having an operating voltage of 20 Vdc minimum, 50 Vdc maximum and will provide 90 minutes of emergency operation.*
- 8) *To reduce the risk of electrical shock, do not connect BLEM series driver's converter connector until installation is complete and AC power is applied to the luminaire.*
- 9) *The BLEM series driver has more than one power source. To reduce the risk of electrical shock, remove the normal AC power source(s) to the luminaire and disconnect the BLEM series driver's converter connector before servicing.*
- 10) *The use of accessory equipment not recommended by the manufacturer may cause an unsafe condition and will void warranty.*
- 11) *Do not use this equipment for other than intended use.*
- 12) *Do not mount near gas or electric heaters.*
- 13) *Servicing of this equipment should be performed by qualified personnel only*
- 14) *The BLEM series driver is a sealed unit. Components are not replaceable. Replace entire unit when necessary.*
- 15) *The BLEM series driver comes with a sealed rechargeable NiCad battery that must be recycled properly. Do not attempt to service the battery.*

SAVE THESE IMPORTANT SAFETY INSTRUCTIONS

The installation and use of this product must comply with all national, federal, state, municipal, or local codes that apply. Please read this manual thoroughly before installing or operating BLEM series Emergency LED Drivers.

INSTALLATION INSTRUCTIONS

CAUTION: Before installing, make certain the AC power is off and the BLEM series driver's converter connector is disconnected.

1. MOUNTING THE EMERGENCY LED DRIVER (BLEM series)

Mount BLEM series driver to the top of the housing or on the inside of the luminaire using mounting tabs and suitable fasteners (not provided). When top-mounting the driver, use wire bundle covers (not provided) to avoid exposed wiring. Refer to Figures 1 and 2.

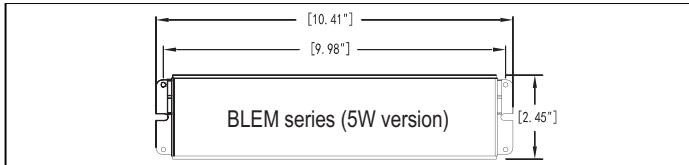

Figure 1

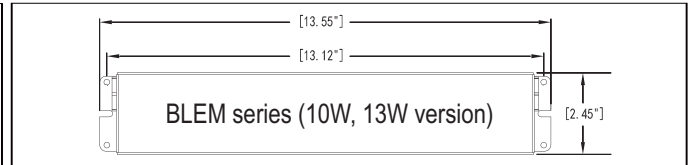

Figure 2

2. WIRING THE BLEM series

Perform all wiring with the exception of the Violet and Brown wires. Note: Wiring must be performed in accordance with the National Electric Code and applicable local codes. Consult Customer Service for additional wiring diagrams.

Refer to Figure 3.

Caution: Use only with LED driver with Output current less than 2.5A.

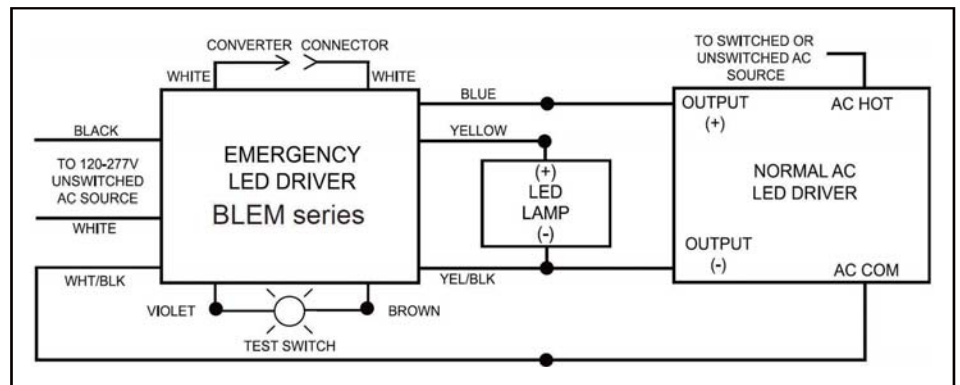

Figure 3

3. INSTALLING THE LED COMBO TEST SWITCH (LCTS)

Recessed Troffer Luminaire – Select a convenient location with proper clearance in the LED Driver cover and drill or punch a 7/8" hole (1/2" knockout). Insert the 7/8" bushing into the hole. Push the plastic tube through the bushing. Route the leads of the LCTS through the plastic tube. Connect the wires from the BLEM series driver to the LCTS (Violet to Violet, Brown to Brown).

Refer to Figure 4 at right.

Strip Luminaire - Select a convenient location on the fixture where the LCTS will be visible after installation. Allow for proper clearance inside the fixture and drill or punch a 1/2" hole. Push the LCTS housing into the 1/2" hole and secure with nut. Connect the wires from the BLEM series driver to the LCTS (Violet to Violet, Brown to Brown).

Refer to Figure 5 at right.

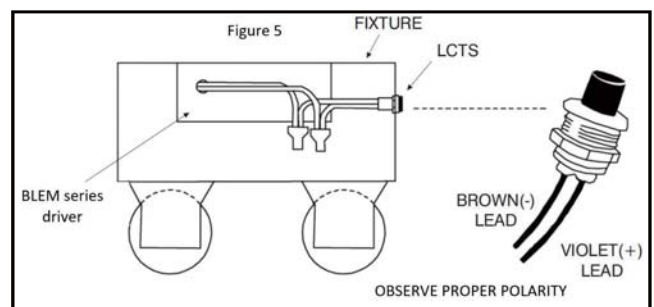
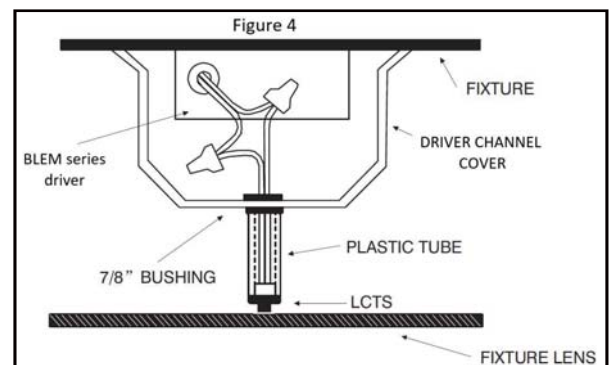

4. WIRING THE AC INPUT

- A) The BLEM series driver and AC LED Driver must be on the same branch circuit.
- B) The BLEM series driver requires an unswitched AC power source of 120 to 277 volts.
- C) When the BLEM series driver is used in a switched luminaire, the AC input to the BLEM series driver must be connected to ahead of the luminaire switch (line side of luminaire switch).

Refer to Figure 3.

5. COMPLETING INSTALLATION

When the installation is complete, switch the AC power ON and join the BLEM series driver's converter connector.

Refer to Figure 3.

OPERATION

Normal Mode – AC power is present. The AC LED Driver operates the LED lamp(s) as intended. The LCTS will be illuminated indicating that the BLEM series driver is in the standby charging mode.

Emergency Mode – AC power fails. The BLEM series driver senses the AC power failure and automatically switches to Emergency Mode. One or multiple LED lamps will be illuminated for a minimum of 90 minutes. When AC power is restored, the BLEM series driver switches the system back to the Normal Mode and resumes battery charging.

TESTING AND MAINTENANCE

Pressing the LCTS simulates an AC power failure and forces the system into the Emergency Mode. Only the emergency LED lamp (s) will be illuminated. Testing may also be performed by opening circuit breaker powering the system.

Initial Testing – Allow the unit to charge for approximately 1 hour, then press the LCTS to conduct a short test. Allow a 24 hour charge before conducting a 1 ½ hour test.

Monthly – Ensure that the LCTS is illuminated. Conduct a 30 second test by depressing the LCTS

Annually – Ensure that the LCTS is illuminated. Conduct a 1 ½ hour test by opening circuit breaker controlling the BLEM series driver(s) to be tested.

Written records of testing shall be kept on file for inspection by the authority having jurisdiction.

BLEM Series System Coordination Guidelines

These guidelines were developed to allow the lighting system Designer/Specifier to predict the operating performance levels of LED luminaires when powered by an electrically compatible BLEM series model. It is ultimately the responsibility of the Designer/Specifier to ensure that the as installed system delivers code-compliant path of egress illumination.

1) Determine Electrical Compatibility

- A) Verify that the Luminaire LED Driver, where applicable, is Class 2 compliant.
- B) Verify that the Luminaire LED Lamp(s) have an operating voltage between 20Vdc and 50Vdc.
- C) Verify that the Luminaire LED Lamp(s) have a power rating equal to, or greater than, the emergency power rating of the BLEM series driver model under consideration.

Refer to Table 1 below.

TABLE 1

MODEL	EMERGENCY OUTPUT (CONSTANT)
BLEM series driver	5.0 WATTS or 10.0 WATTS or 13.0 WATTS

2) Calculate Lumen Output During Emergency Operation

- A) Access luminaire data by logging onto Design Lites Consortium (www.designlights.org).
- B) Select "Search the DLC Qualified Product List" on the DLC homepage.
- C) Enter manufacturer name and P/N of luminaire under consideration in the "search by keyword" text window.
- D) Select "Search" tab to open the "Qualified Products List".
- E) Determine luminaire Lumens per Watt efficacy in "Rated Data" specifications.
- F) Multiply luminaire Lumens per Watt by Emergency Output of the BLEM series model under consideration.

Refer to Table 1 above.

This figure is the Lumens available from the luminaire during emergency operation.

3) Determine Suitability of Means of Egress Lighting Levels

- A) Using industry standard lighting design software, along with IES files for the luminaire under consideration, verify that the as installed available Lumens (as calculated in 2F above) are sufficient to meet Code-compliant path of egress illumination levels.

While the BLEM series driver has been found compliant with the requirements of UL Standard 924, it is ultimately the responsibility of the Designer/Specifier to assure the as-installed system delivers code-compliant path of egress illumination in accordance with Federal, State or local municipal requirements.