

Installation

1. Remove 2x2 or 2x4 or 1x4 the from ceiling

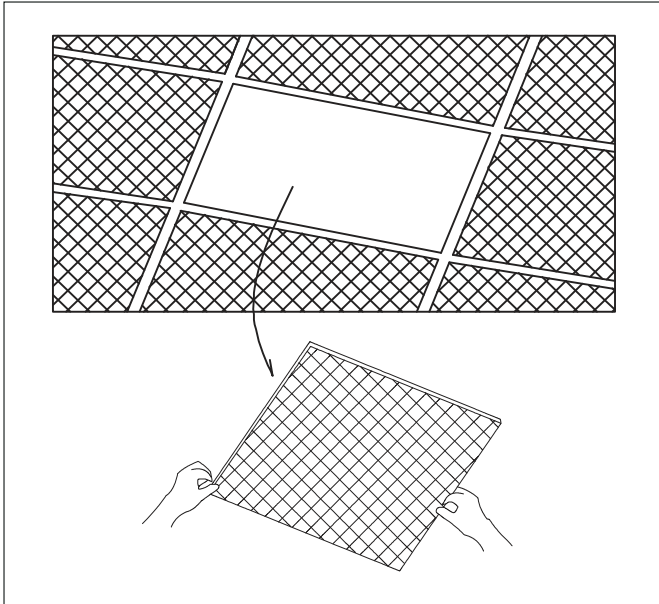

2. Put on the LED panel.

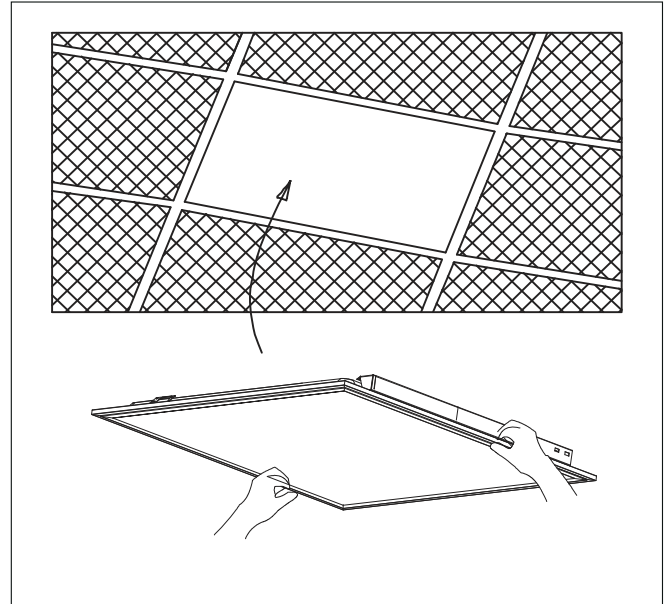

3. Connecting wire: Pls connect AC wire of driver at L(Black),N(White) and G(Green) for normal working; if dimming function needed, it also needs be connected for the both dimmable wires in grey and purple.

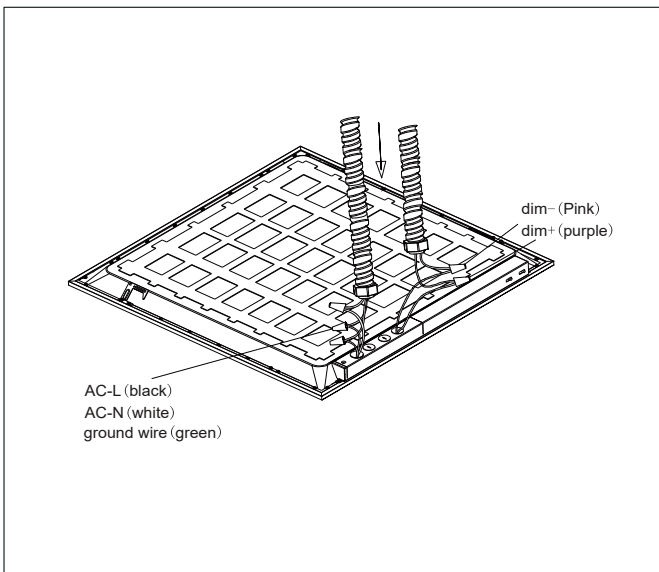

4. Fixed wire hose on the panel, Then installation is completed.
(0-10V CCT&Watts adjustable isolated-driver)

