

# Specification

Mode	Size	Power	Input Voltage	Dimmable	PF	Light Efficacy	Ra	CCT
OSL-ST-4	4FT	30/35/40W	AC100-277V	0-10V	>0.9	150lm/w	80	3500/4000/5000K
OSL-ST-8	8FT	60/70/80W	AC100-277V	0-10V	>0.9	150lm/w	80	3500/4000/5000K

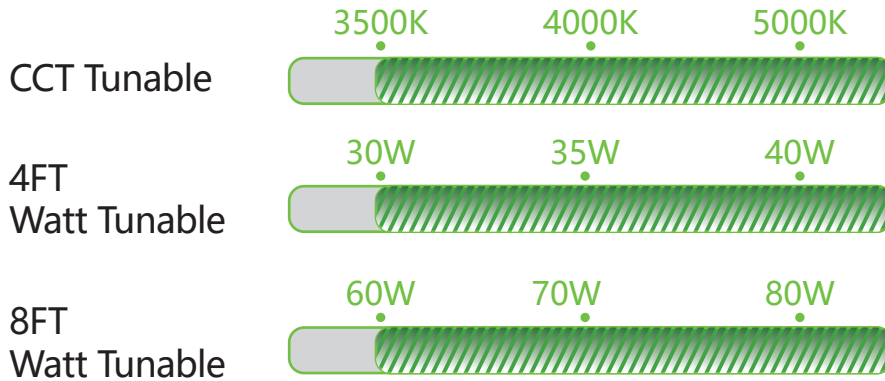

# Installation

## Surface Mounted Installation

1. Insert the Anchors into the hole as picture.

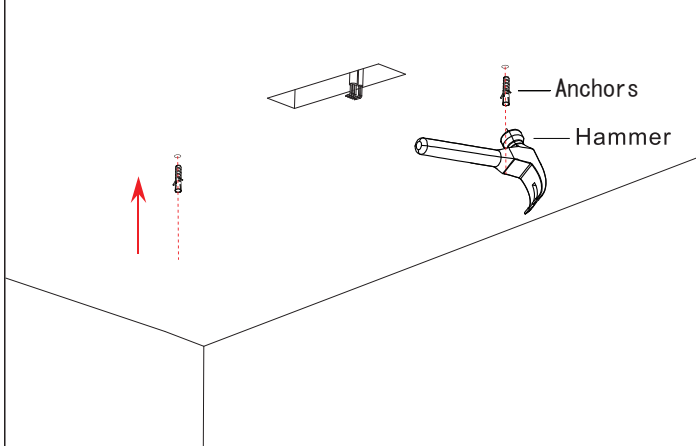

2. Press the button then open the PC housing.

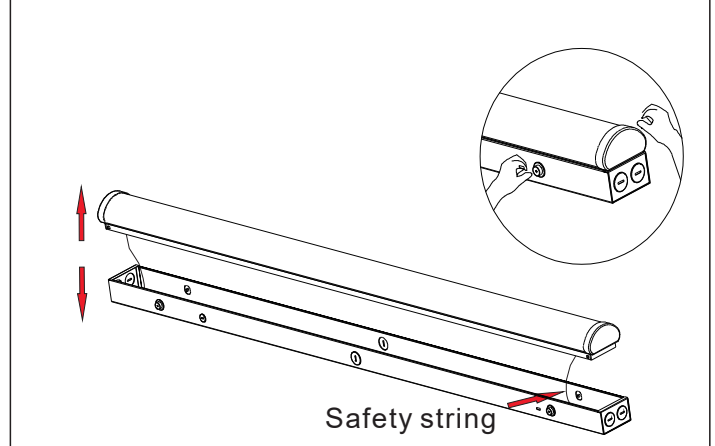

3. Adjust the hole of bottom cover align at anchors, then fasten it by screw.

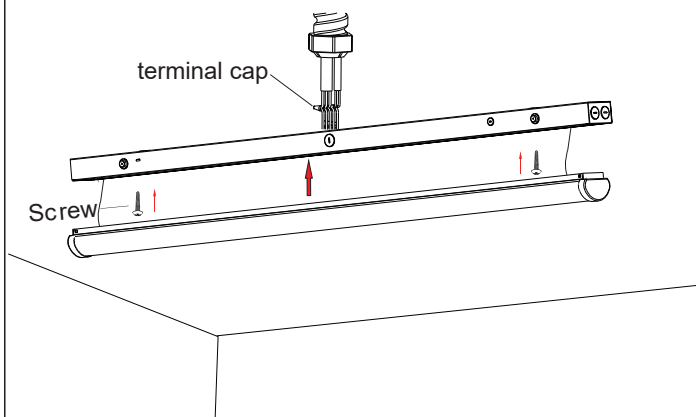

4. Press the button, then let the PC housing return to original place. Open the PC cover then adjust the DIP switch

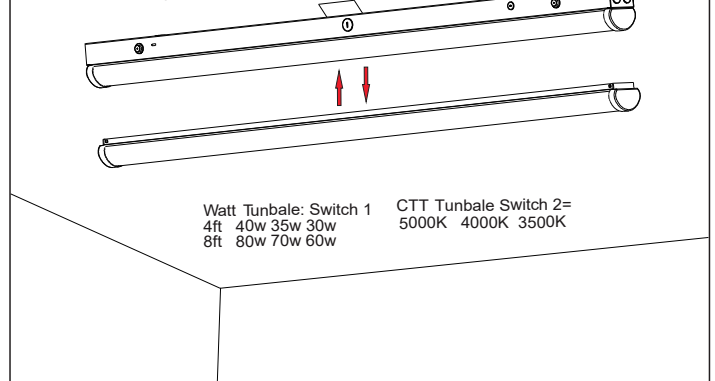

# Installation

## Suspension installation

1. Drill two holes in the ceiling with electrodrill, put the hook into the hole.

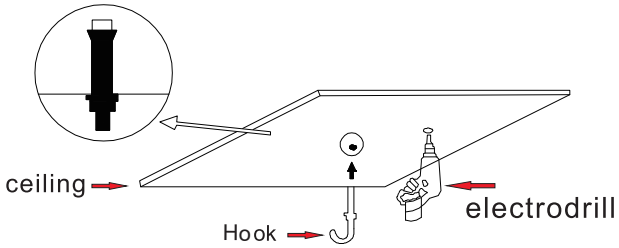

2. Put the hook into the holes as picture.

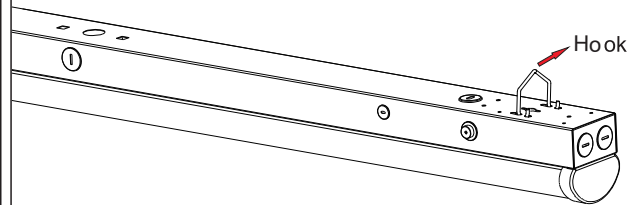

3. One side of safety rope to connect the hook, the other connect the lifting hook.

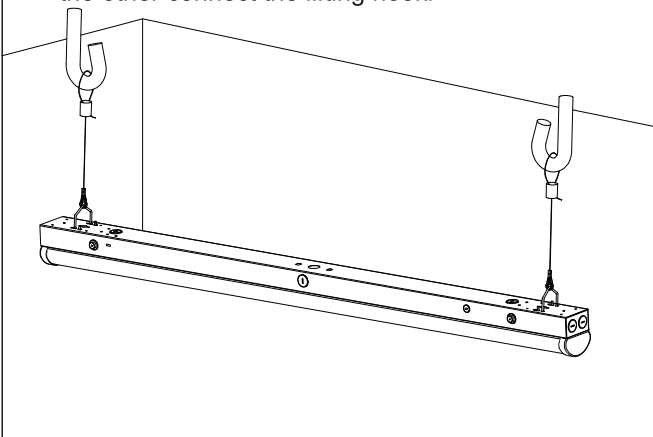

4. Turn off power, and make wiring connections with terminalcap.(see wiring instruction below).

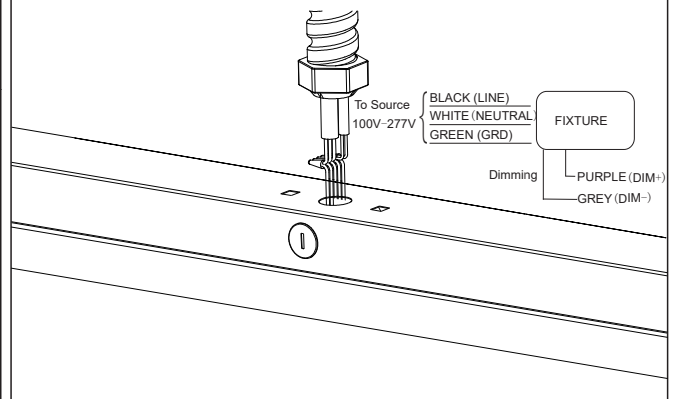

5. Insert the terminal block and wires into the strip.

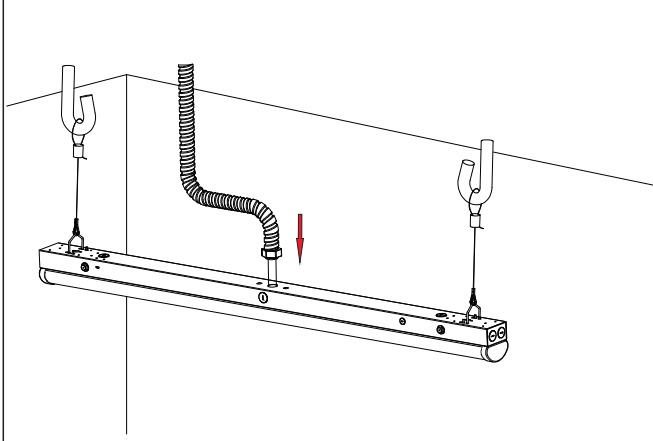

6. Insert the wire terminal joint to the wire entry.

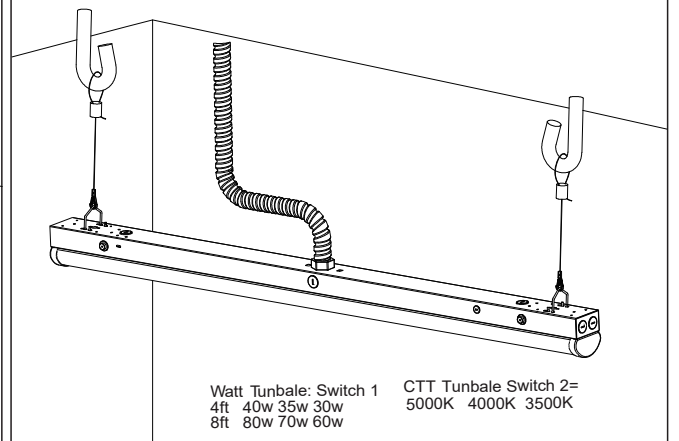

**The Installation must be carried out by a qualified electrician.**

# Installation

## Connection for option

1. Fix the connection bracket on the wall.

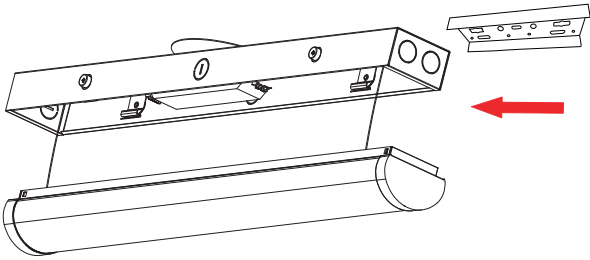

2. Insert the strip light into the connection bracket, then drill holes at a suitable position in the wall for installing the next strip light.

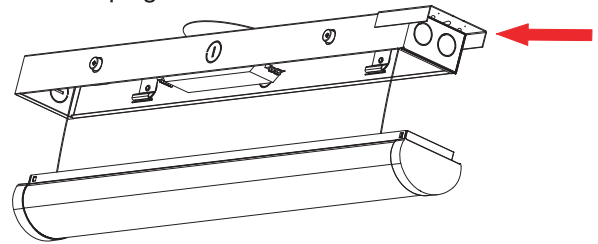

3. Fix the lamp body on the wall by screws, complete the installation; repeat the previous procedure to install the 3rd strip light, 4th strip light etc.

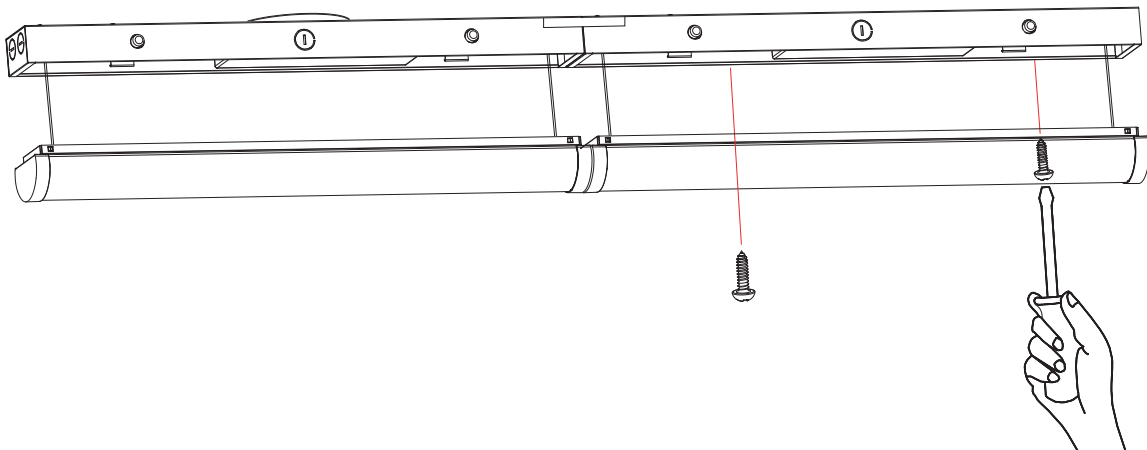

4. Wiring schematic as shown.

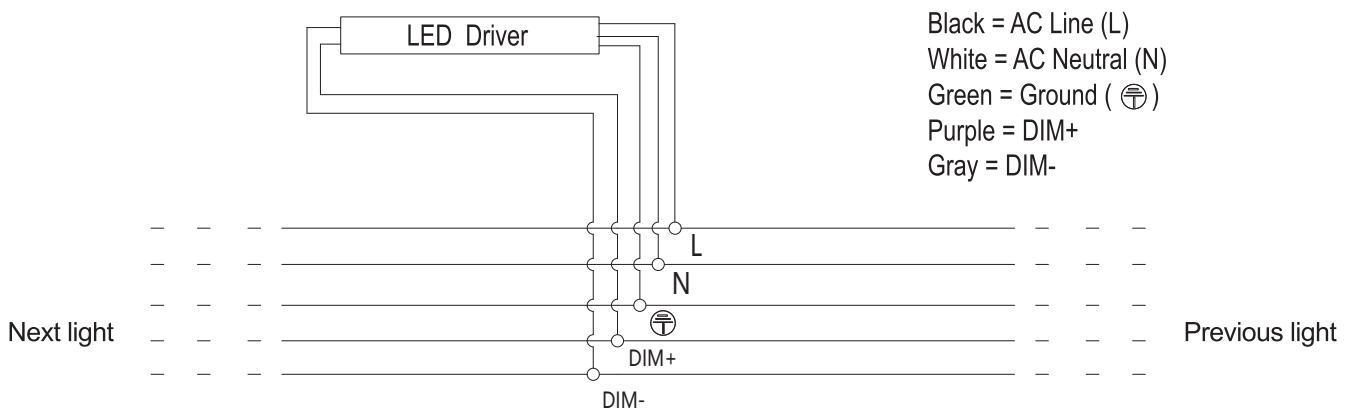

# Installation

## Connection for option

5. Pass wires through the knockout hole, fix the wires with 3M glue.

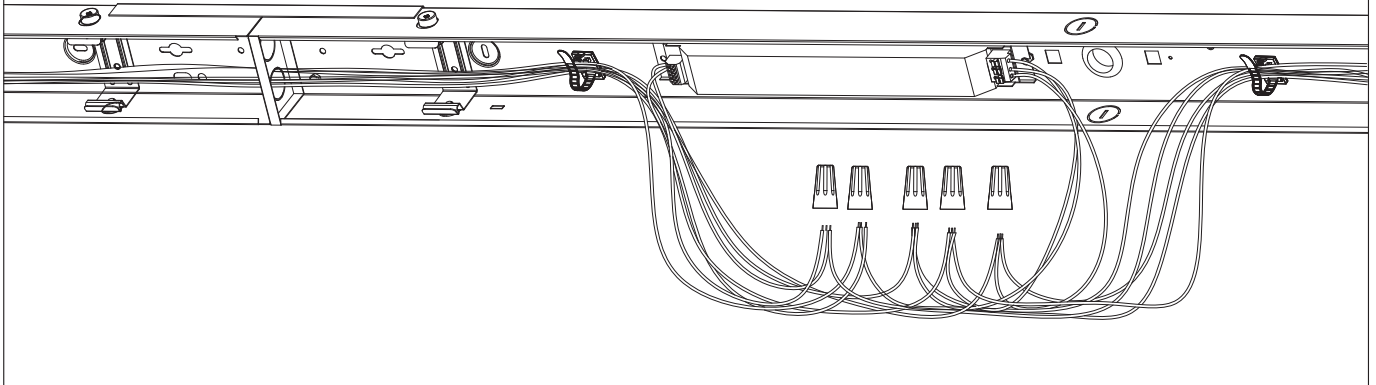

6. The same type of electronic wires are inserted into the same quick connector and combined into a parallel circuit.

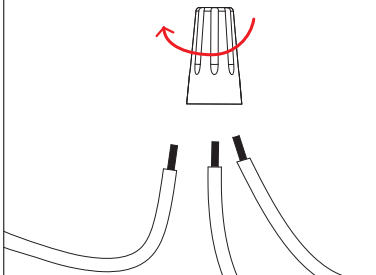

7. Tighten the wires in the quick connector, as the photo shows below.

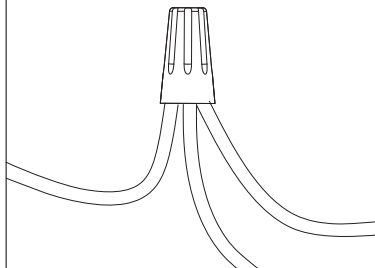

8. As shown in the figure, it is the diagram of wiring completion.

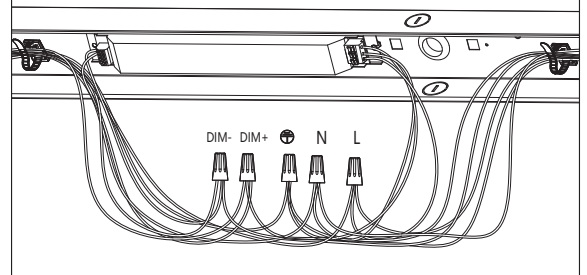

9. After finished wire connecting and install back the housing, Light up.

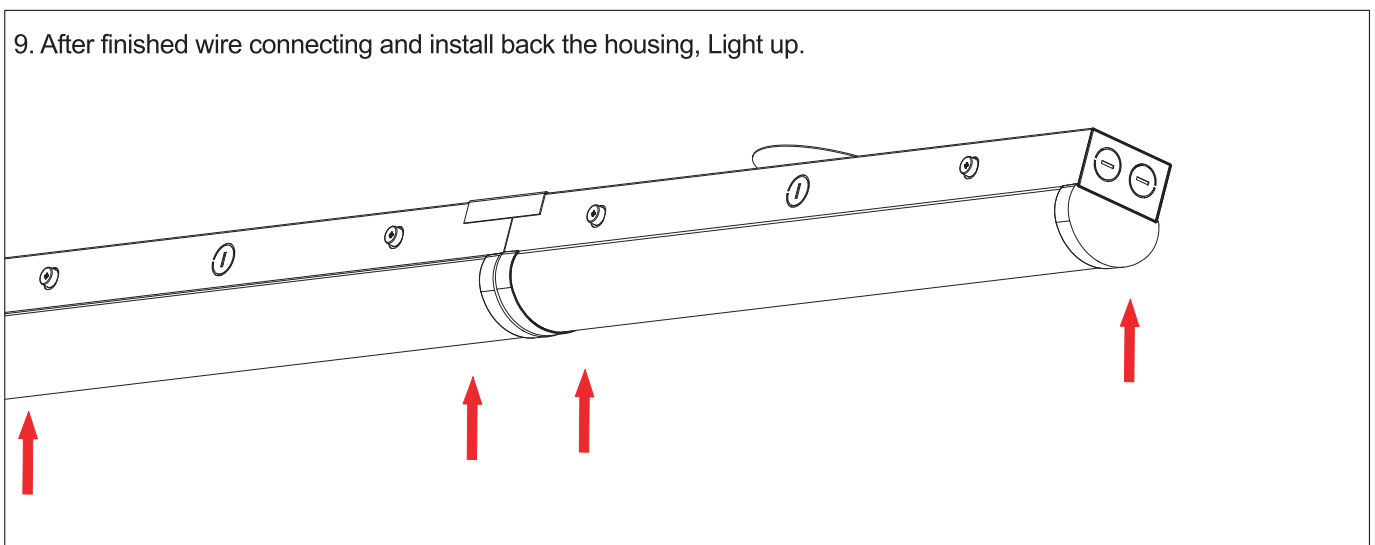

# Infrared integrated sensor

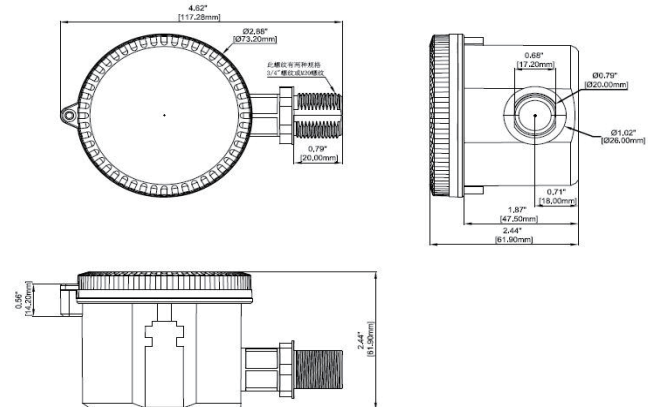

1/On/Off function /3-step dimming function: After power on, the sensor automatically turns on light at 100% brightness. After 10sec, it turns off the light. During the initialization, the sensor is not able to detect movement.

2/2-step dimming function: After power on, the sensor automatically turns on light at 100% brightness. After 10sec, it dims the light to a low light level(set by stand-by dim level). During the initialization, the sensor is not able to detect movement.

Input	Operating Voltage Range	108-305V AC, 50Hz/60Hz
	DC Input Voltage	N/A
	Rated Voltage	120/277Vac, 50/60Hz
	No-load Power	N/A
	Stand-by Power	<1W
	Surge Test	L--N: 2kV
Output	Working Mode	ON/OFF function, 1-10V step dimming
	Type of Load	Inductive or resistive Load
	Load Capacity	120VAC: 4A; 277VAC: 3A
	Current of Load	N/A
	Max. Surge Capacity	50A (50% I <sub>peak</sub> , t <sub>width</sub> =500uS, 277Vac full load, cold start); 80A (50% I <sub>peak</sub> , t <sub>width</sub> =200uS, 277Vac, full load, cold start)
Dim Interface	1-10V Dimming	< 50mA (Non-constant source) 10%(1.4-1.6V), 20%(1.9-2.1V), 30%(2.9-3.1V), 50% (4.9-5.1V)
	Synchronous Control	N/A
	High Low-level	N/A
	PWM Control	N/A
Sensor Parameters	Operating Frequency	5.8 GHz ±75 MHz, ISM Band.
	Transmitting power	0.5mW Max.
	Hold time	DIP switch: 5s/30s/1min/3min/20min/30min Remote control: 5s/30s/1min/3min/5min/10min/20min/30min
	Stand-by DIM Level	DIP switch & Remote control: 10%/20%/30%/50%
	Stand-by Period	DIP switch: 0s/1min/3min/10min/30min/+∞ Remote control: 0s/10s/1min/3min/5min/10min/30min/+∞

# Mounted to led strip lowbay light

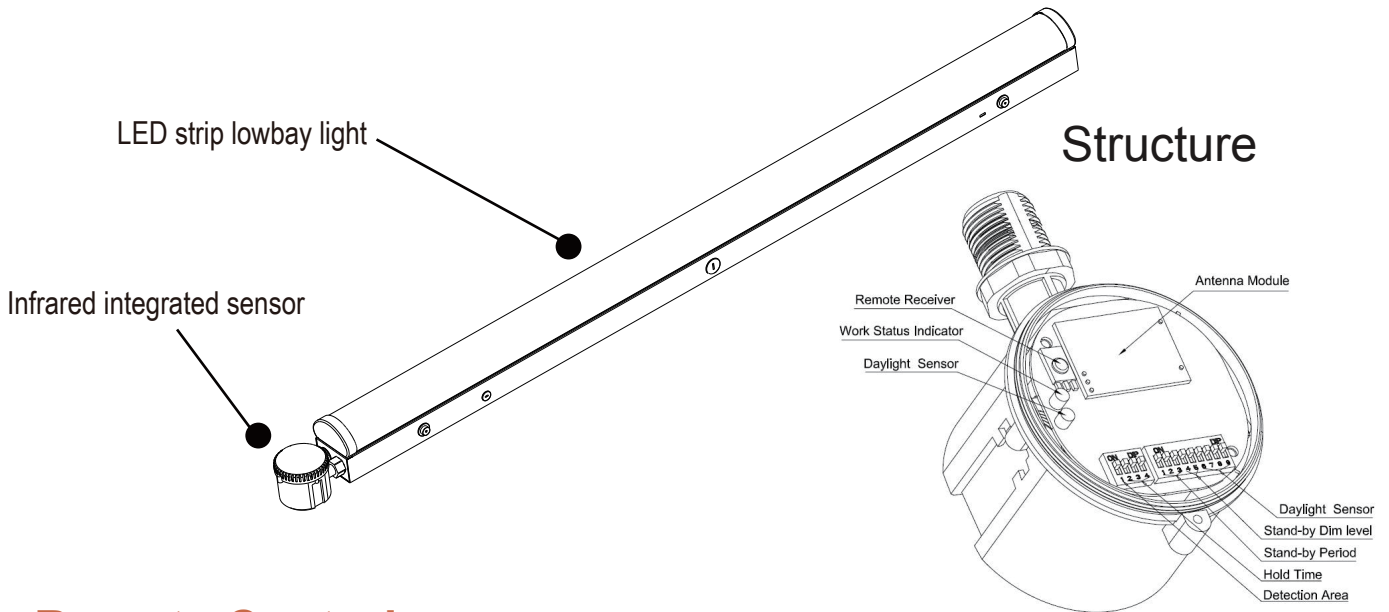

# Remote Control

Remote Control Setting	Button	Remarks																												
	ON/OFF	Press the "ON/OFF" button, the light goes to constant on/off mode, sensor is disabled. Press "Reset" "Sensor motion" button to quit from this mode and the sensor starts to work.																												
	Reset	Press "Reset" button, all parameters are same as setting of factory settings.																												
	Sensor motion	Press "Sensor motion" button, the light quits from the constant on/ off mode, and the sensor starts to work ( The latest setting stays in validity )																												
	DIM Test	Press "DIM Test" button, the 1-10 V dimming works to test whether the 1-10Vdc dimming ports are connected properly. After 2s, it returns to the latest setting automatically.																												
	Override DH, Disable, DIM+, DIM-, DH Mode	"Override DH", and "DH Mode" that the two functions are not applicable for MC054V RC2.																												
	Q1, Q2, Q3	<table border="1"> <thead> <tr> <th>Scene Options</th> <th>Detection Area</th> <th>Hold Time</th> <th>Stand-by period</th> <th>Stand-by dim level</th> <th>Daylight Sensor</th> <th>Sensitivity model</th> </tr> </thead> <tbody> <tr> <td>Q01</td> <td>100%</td> <td>5min</td> <td>10min</td> <td>10%</td> <td>30Lux</td> <td>Hs</td> </tr> <tr> <td>Q02</td> <td>100%</td> <td>10min</td> <td>30min</td> <td>10%</td> <td>Disable</td> <td>Hs</td> </tr> <tr> <td>Q03</td> <td>100%</td> <td>20min</td> <td>30min</td> <td>10%</td> <td>Disable</td> <td>Hs</td> </tr> </tbody> </table> <p>Note: Detection area / Hold time / Stand-by period / Stand-by dim level / Daylight sensor can be adjusted by pressing the corresponding button. The latest setting will stay valid.</p>	Scene Options	Detection Area	Hold Time	Stand-by period	Stand-by dim level	Daylight Sensor	Sensitivity model	Q01	100%	5min	10min	10%	30Lux	Hs	Q02	100%	10min	30min	10%	Disable	Hs	Q03	100%	20min	30min	10%	Disable	Hs
Scene Options	Detection Area	Hold Time	Stand-by period	Stand-by dim level	Daylight Sensor	Sensitivity model																								
Q01	100%	5min	10min	10%	30Lux	Hs																								
Q02	100%	10min	30min	10%	Disable	Hs																								
Q03	100%	20min	30min	10%	Disable	Hs																								
	TEST 2S	Press the "TEST 2S" button can enter the test mode any time. At the mode, the sensor parameters as below: Detection Area is 100%, Hold Time is 5s, Stand-by Dim Level is 10%, Stand-by Period is 0s, daylight sensor disable. This function only for testing. Quit the mode by pressing "RESET" or any other function buttons.																												
	HS, LS	Press "HS" button to set the detection area to be high sensitive. Press "LS" button to set the detection area to be low sensitive. The adjustment bases on the "Detection Area" parameter you set.																												
	Daylight Sensor	Set up daylight threshold: 5Lux/15Lux/30Lux/50Lux/100Lux/150Lux/ Disable.																												
	Stand-by period	Set up stand-by time: 0S/10S/1min/3min/5min/10min/30min/+∞																												
	Hold time	Set up hold time: 5S/30S/1min/3min/5min/10min/20min/30min																												
	Stand-by dim level	Set up stand-by dim level: 10%/20%/30%/50%																												
	Detection Area	Set up detection area: 25%/50%/75%/100%																												
	Remote Distance	Toggle button can set the remote distance of remote control and sensor.																												



# Function

## 1.(On/OFF Function(stand-by period be set to "0"s)

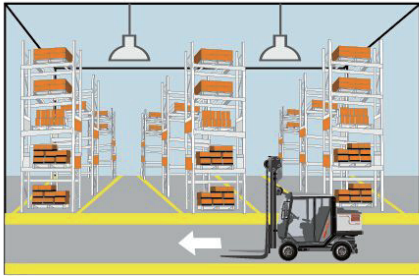

1 With sufficient ambient light, the light will not be switched on even if with motion signal.

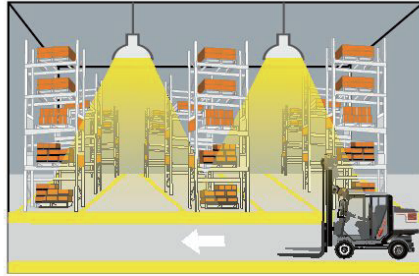

2 With insufficient ambient light, the sensor switches on the light when motion is detected.

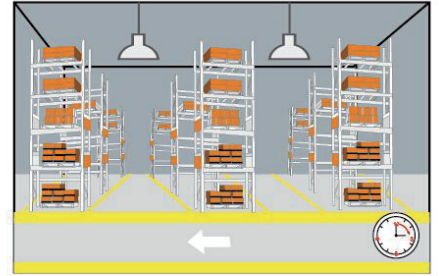

3 After elapse of hold time, the sensor switches off the light when no motion is detected.

## 2.(step dimming function(stand-by period be set to "+o")

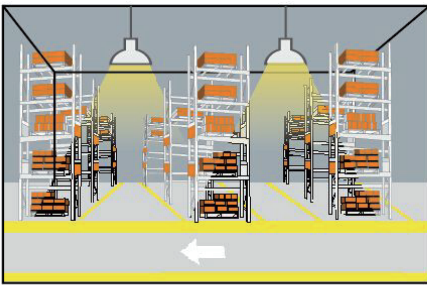

1 If there is no motion detected, the light will be remained at a low light level all the time.

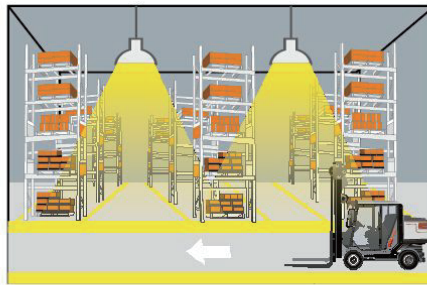

2 When motion is detected, the sensor will switch on the light to 100% brightness

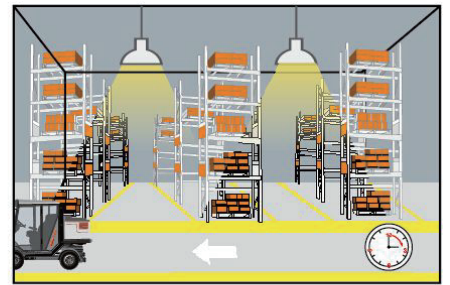

3 After elapse of hold time, the sensor dims the light at the present low light level if no motion is detected.

## 3.(step dimming function(stand-by period be set to "10s/1min/3min/5min/10min/30min")

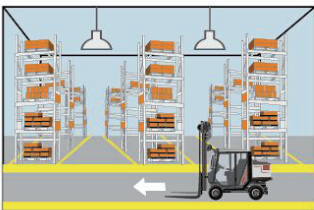

1 With sufficient ambient light, the light will not be switched on even if with motion signal.

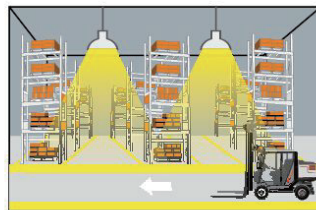

2 With insufficient ambient light, the sensor switches on the light when motion is detected.

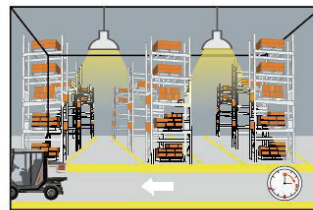

3 After elapse of hold time, the sensor dims the light at a low light level if no new motion is detected.

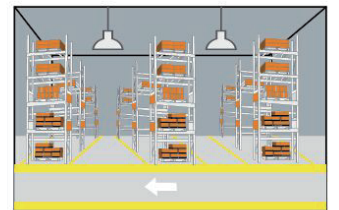

4 After elapse of standby period, the sensor switches off the light if no motion is detected in the detection zone.

# Emergency LED Driver

## Wiring Diagram

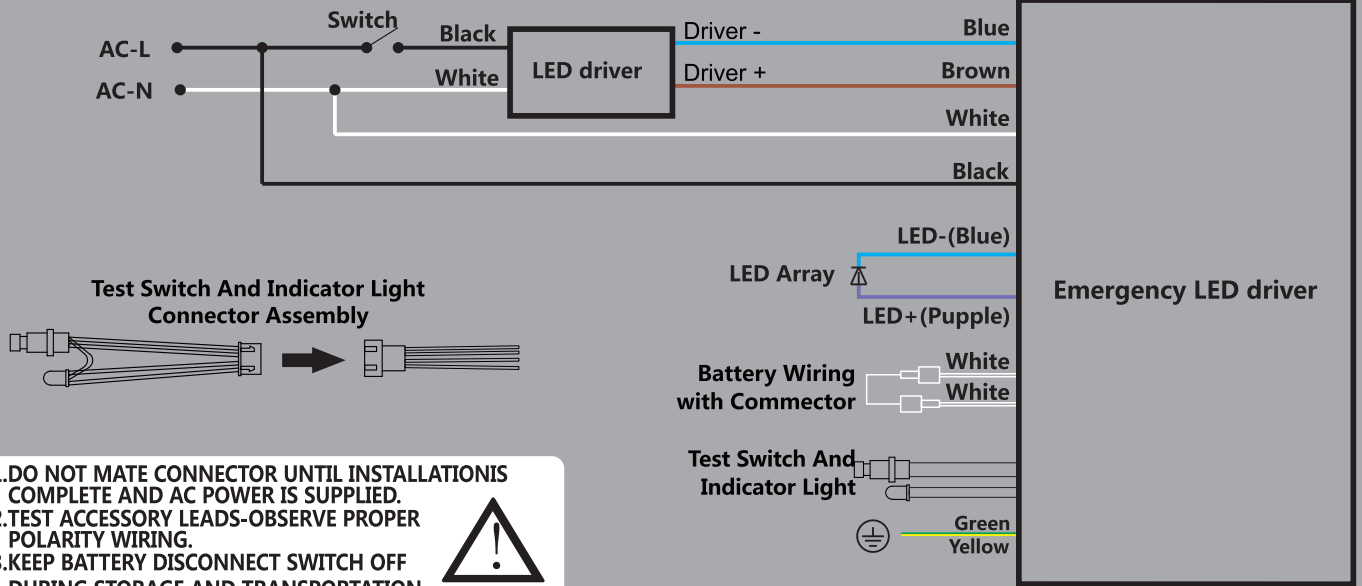

1. DO NOT MATE CONNECTOR UNTIL INSTALLATION IS COMPLETE AND AC POWER IS SUPPLIED.
  2. TEST ACCESSORY LEADS-OBSERVE PROPER POLARITY WIRING.
  3. KEEP BATTERY DISCONNECT SWITCH OFF DURING STORAGE AND TRANSPORTATION
- 

## Dimensions

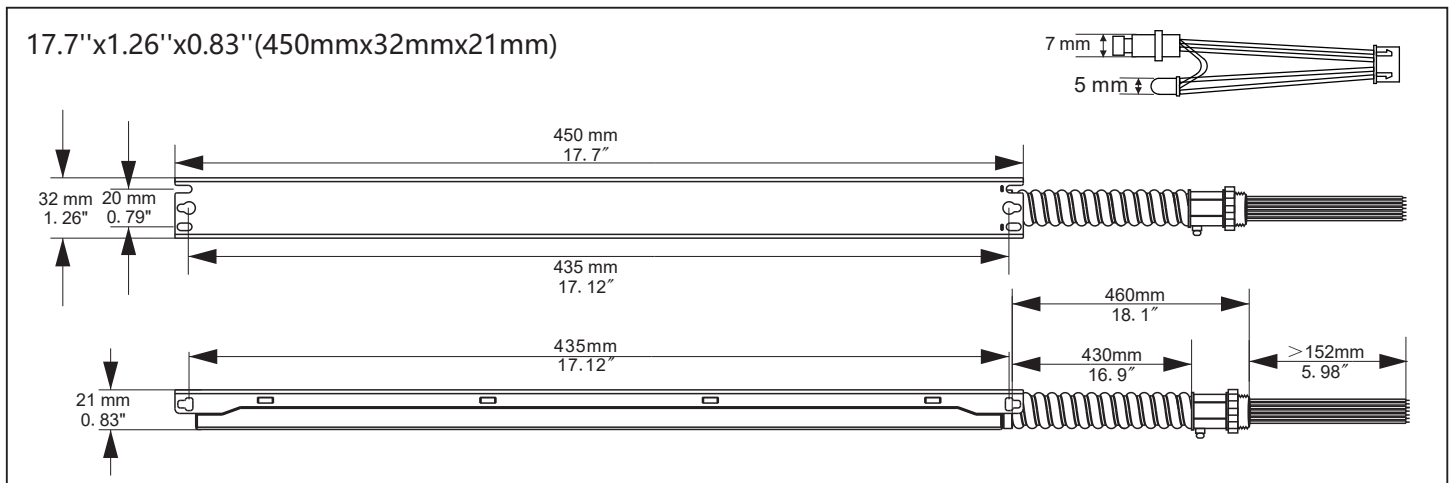



## Operation

### AC Operation:

AC power is present, The LED load from the LED driver is normal power supply, AC LED driver output current can not exceed 150W or 4A, the emergency driver is charging in a standby mode. The green LED light flashes indicates that it is charging. The green LED light on indicates that it is full charged. After the AC power supply working 48h, The emergency LED drive will automatically from AC power working switch into emergency working mode for 30S every month and then automatically backs to the working mode of the AC power supply, the AC power supply works per year for automatically from the AC power mode backs to the working emergency mode Until the emergency discharge is completed.

### Emergency operation:

When the AC power goes out, The emergency driver detects the AC power outage and automatically switch to the emergency mode.

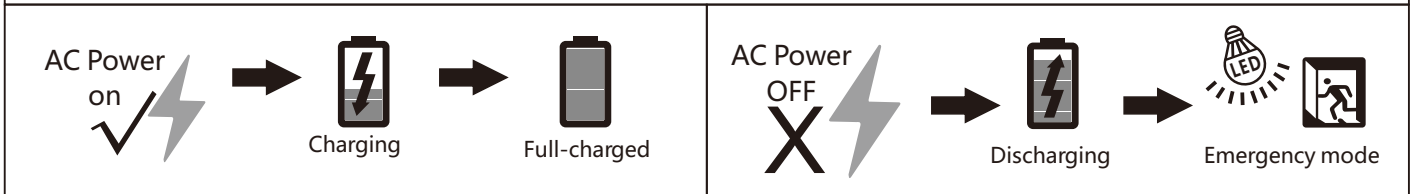

## Indicator light introduction

- ① Green/flashing: Charging
- ② Green/on: Full-charged
- ③ Red/on: Discharging(emergency mode)
- ④ Red/flashing: Discharging(emergency mode) finished soon
- ⑤ Yellow/on: Error

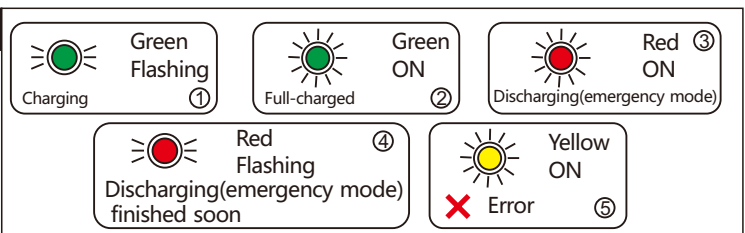

## Test switch introduction

Press the test switch to confirm whether the emergency function is normal



## IMPORTANT SAFEGUARDS

When using electrical equipment, basic safety precautions should always be followed including the following

### READ AND FOLLOW ALL SAFETY INSTRUCTIONS.

- Risk of fire or electric shock. Luminaire wiring and electrical parts may be damaged when drilling for installation of LED Emergency Backup. Check for enclosed wiring and components.
- Risk of fire or electric shock. This LED Emergency Backup installation requires knowledge of luminaire. electrical systems. If not qualified, do not attempt installation. Contact a qualified electrician.
- Before installing, make certain the AC power to the fixture is off.
- The electrical rating of this product is 100-347Vac. Installer must confirm that there is 100-347Vac to the fixture before installation.
- To prevent electrical shock only mate unit connector after installation is complete and before the AC power to the fixture is back on.
- This LED Emergency Backup unit requires an un-switched AC power source of 100-347Vac, 50/60Hz. The AC driver must be on the same branch circuit as the LED Emergency Backup unit.
- Do not let power supply cords touch hot surfaces.
- Do not mount near gas or electric heaters.
- Do not use outdoors.
- Do not connect battery pack connector until all other wiring is complete and AC power is on.
- The emergency LED driver is for use with grounded, UL listed LED luminaires, shall be enclosed by the LED luminaire and bonded to the grounding of LED luminaire.
- Verify that all replacement lamp types marked on the installed luminaire are also identified as suitable for use with this emergency battery pack.
- The battery pack is fixed by the screw and the indicator lamp is attached to the shell of the luminaire by 3M tape.
- Equipment should be mounted in locations and at heights where it is not be subjected to tampering by unauthorized personnel.
- The use of accessory equipment not recommended by the manufacturer and may cause an unsafe condition.
- Do not use this equipment for other than its intended use.
- Use with grounded, UL Listed, dry or damp location rated fixtures.

