

T-Grid Linear

Recessed | Architectural LED Linear



T-Grid LED Linear is a new generation green lighting solution that integrated into T-Grid suspended ceilings, allowing to be fully and integrated into 9/16" flat, 9/16" slot, 9/16" interlude or 15/16" flat T-grid. It can replace selected cross tees of the suspended grid ceiling system where light is desired. The innovative separable design of led module and T-grid bracket makes it more flexible. One T-grid bracket allows for integration of multiple LED modules with different CCT with easy and tool-free installation. This innovative produce design brings both performance and aesthetics to any design applications.

Feature

US Patent, UL, cUL, DLC

Available in 2' and 4' with remote driver

Flexible separable design of LED module and T-grid bracket

Plenum rated cable, connector, emergency option available

Continuous runs and custom pattern

CCEA option available

Fit most ceiling types



9/16" Flat 9/16" Slot 9/16" Interlude 15/16" Flat

PERFORMANCE

Grid Type	Efficacy
9/16"	580LM/FT, 5W/FT
15/16"	650LM/FT, 5W/FT

All efficacy is ±5% base on different CCT. Check the IES file to gain the accurate data.

US PATENT
10125934



*DesignLights Consortium Qualified and classified for DLC standard/premium, refer to www.designlights.org for details

T-Grid Linear

Recessed | Architectural LED Linear

STRUCTURE

► Optics

Unique design with triple sides allows the light to diffuse for a direct and indirect lighting combination with 120° beam angle.

► Electrical

Remote LED Driver	<ul style="list-style-type: none">•3pcs 2' LED lights per 30w remote driver•3pcs 4' LED lights per 60w remote driver•Max distance from fixtures to power supply is 8 feet with 24 AWG wire with RJ45 terminal, which makes easy installation and safe wiring.
Dimming	Standard constant current electronic driver with 1-10V dimming input; dimming range from 100% down to 10%. Tested Dimmers: Lutron® Diva-Dvtv, Leviton® IP-710-DL. Thermal overload protection shuts down the luminaire when system temperatures exceed designed operating conditions.
THD	<20%
Power Factor	>0.9
Input Voltage	Standard electronic drivers are cULus recognized and available for 100-277V AC or 24VDC*.

► LED System

CRI	Minimum 80 color rendering index
CCT	3000K, 3500K, 4000K and 5000K with a great color consistency
LED	life Minimum 50,000h with 87.8% of lumen maintenance in 25°C ambient temperature, in compliance with IES LM-80 testing measurements.
Thermal Management	Aluminum housing acting as the heat sink to maximize life.

► Mounting

- It is a lighting solution that can be replaced with 9/16" and 15/16" removable cross tee of the grid ceiling, allowing our linear light to be integrated into the suspended ceiling.
- Custom pattern
- Plenum rated cable and connector option

► Approvals

- US Patent (10125934)
- cULus listed for damp locations
- Tested to IESNA LM-79 and LM-80
- DesignLights Consortium Qualified and classified for DLC standard, refer to www.designlights.org for details
- CCEA listed
- IC Rated
- 5 years limited warranty

► Optional Function

Emergency Option



Optional high voltage 8W emergency LED driver EM-H08170-LBF can be provided. When AC power fails, it immediately switches to the emergency mode, operating for lighting up to 120 minutes. When AC power is restored, it automatically returns to the charging mode which meets critical life-safety lighting requirements.

For more info or spec sheet, please visit our website or contact sales.

Emergency Lumen Output:

Fixture Efficacy	Output Power 8w
110lm/w	880 Lumens

PRODUCT ORDERING GUIDE

Sample

$\frac{TB}{1} \frac{4}{2} - \frac{DM}{3} - \frac{35}{4} \frac{U}{5}$

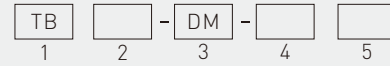

1. Base Model

TB

2. Length & Wattage

- 2 2' 10w
 4 4' 20w

3. Dimming

DM 1-10V Dimming (10%-100%)

4. CCT

- 30 3000K *
 35 3500K
 40 4000K
 50 5000K *

5. Grid Type

- F 9/16" Flat - Custom pattern
 S 9/16" Slot - Custom pattern
 I 9/16" Interlude *
 U 15/16" Flat - Custom pattern

OPTIONAL ORDERING GUIDE

Optional Functions

LED Emergency Driver (Order Separated)

*Additional cost and/or lead time on customized fixtures may apply. Some fixtures require an MOQ. Please contact your sales rep for more information.

T-Grid Linear

Recessed | Architectural LED Linear

T-GRIDS CEILING COMPATIBILITY

9/16" Flat



Suprafine® XL

9/16" Slot



Silhouette® 1/4" XL



Silhouette® 1/8" XL

9/16" Interlude



Interlude® XL



Sonata® XL

15/16" Flat



Prelude® XL



Clean Room

CUSTOM PATTERN



T-Grid LED can be installed in many configurations by replacing any of the cross tees between the main runners of the grid ceiling assembly.

It is free to create compelling spaces, and your space no longer has to be restricted to a single pattern on the ceiling. Custom pattern such as "L", "T", "+", "□" etc.

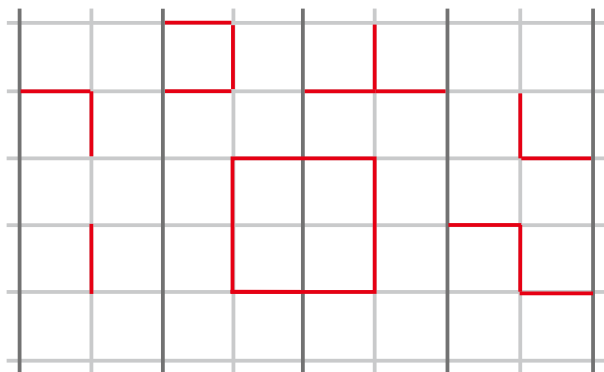

- Examples of configurations
- Possible positions for T-grid LED light modules
- One-piece main runner cannot be replaced

Custom Pattern Version

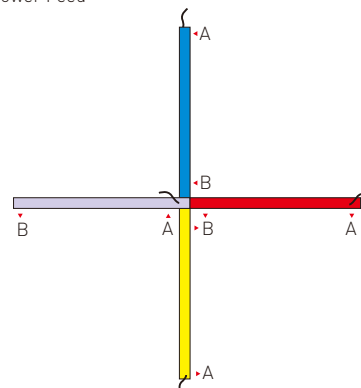

Remark: Only one A-end with wire in joint

T-Grid Linear

Recessed | Architectural LED Linear

DIMENSION

9/16" Flat
Custom pattern

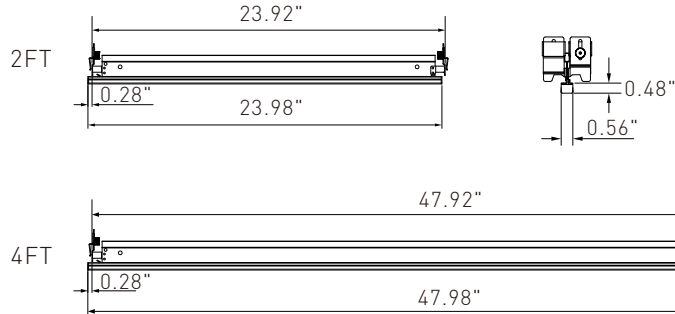

9/16" Slot
Custom pattern

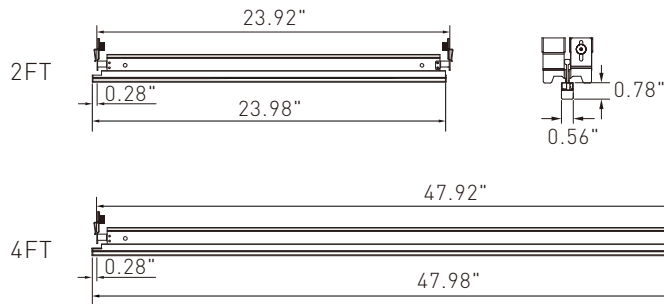

9/16" Interlude

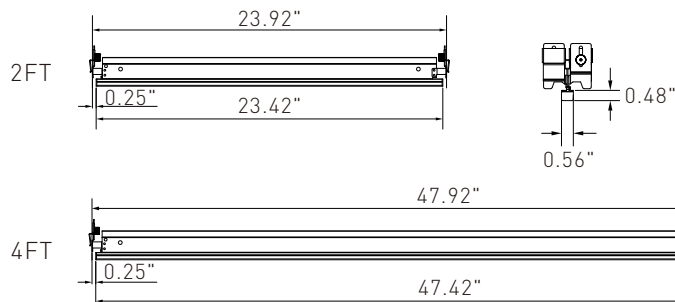

15/16" Flat
Custom pattern

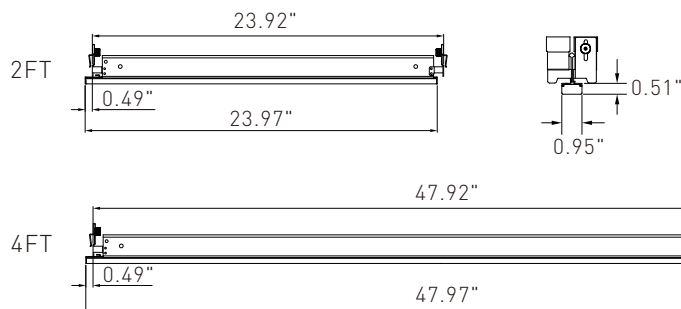

T-Grid Linear

Recessed | Architectural LED Linear

DISTRIBUTION DIAGRAM

2' : 9/16" Flat

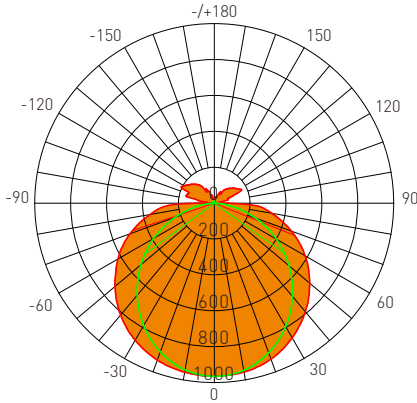

AVERAGE BEAM ANGLE(50%): 123.8°

Test Number: TB2-DM-35F
 Lumens: 3648.5 Lm
 Watts: 30 W
 LPW: 121.62 Lm/W
 CCT: 3500K

UNIT: cd
 — CD/180,139.6
 — C90/270,108.0

Zonal Flux Diagram

τ	C0	C45	C90	C135	C180
10	955.6	950.8	945.9	951.0	956.1
20	924.4	910.7	887.0	913.1	930.1
30	867.6	839.9	795.0	848.5	882.2
40	789.3	746.1	678.0	758.4	813.4
50	693.1	635.1	545.0	653.8	722.6
60	583.9	512.6	399.3	535.0	620.3
70	458.0	379.2	245.9	405.5	500.9
80	324.6	242.7	95.57	269.6	364.7
90	80.83	70.90	4.782	90.84	103.1
100	10.41	40.45	4.675	79.89	92.34
110	80.23	101.4	3.240	132.4	156.4
120	157.0	92.75	3.333	126.5	194.7
130	130.3	79.22	4.397	111.0	164.9
140	103.6	46.74	4.536	83.33	134.2
150	74.85	31.85	4.673	37.28	94.14
160	33.69	21.34	4.675	30.00	39.77
170	19.10	10.73	4.538	14.30	24.94
180	4.119	5.222	5.184	5.553	5.017
DEG	LUMINOUS INTENSITY:cd				

Zonal Lumens

τ	φ total
0-10	91.38
10-20	354.8
20-30	758.5
30-40	1255
40-50	1787
50-60	2299
60-70	2738
70-80	3062
80-90	3249
90-100	3274
100-110	3348
110-120	3448
120-130	3534
130-140	3591
140-150	3625
150-160	3642
160-170	3648
170-180	3649
UNIT: lm	

Luminance cd/(m2)

G(DEG)	C0/180	C90/270
85	30352	4171
80	18706	5562
75	15121	6540
70	13398	7179
65	12392	7643
60	11685	7987
55	11183	8254
50	10789	8480
45	10526	8670

4' : 9/16" Flat

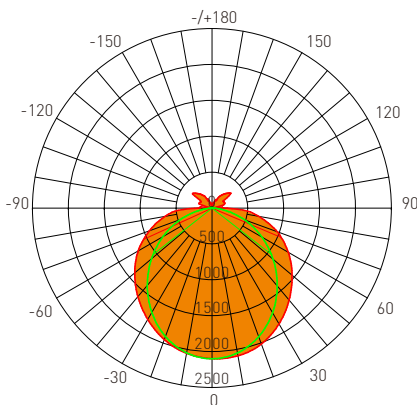

AVERAGE BEAM ANGLE(50%): 118.0°

Test Number: TB4-DM-35F
 Lumens: 7350.5 Lm
 Watts: 60 W
 LPW: 122.51 Lm/W
 CCT: 3500K

UNIT: cd
 — CD/180,132.4
 — C90/270,103.7

Zonal Flux Diagram

τ	C0	C45	C90	C135	C180
10	2089	2083	2050	2048	2054
20	2014	1987	1906	1924	1950
30	1866	1817	1687	1745	1792
40	1672	1584	1415	1522	1609
50	1456	1328	1113	1277	1407
60	1227	1062	799.1	1027	1186
70	968.4	781.5	480.8	758.3	932.0
80	658.2	505.1	182.5	491.4	664.0
90	166.4	127.1	7.781	142.4	194.9
100	24.14	32.97	7.796	34.79	27.17
110	188.3	112.3	7.871	115.5	192.8
120	185.1	226.2	5.416	234.0	180.1
130	327.7	194.3	6.904	198.3	323.6
140	258.3	121.8	7.795	150.2	255.5
150	129.0	69.50	7.713	106.4	173.5
160	70.62	59.56	7.549	63.88	72.90
170	23.81	27.35	10.02	21.93	23.77
180	6.392	8.461	11.08	8.867	7.927
DEG	LUMINOUS INTENSITY:cd				

Zonal Lumens

τ	φ total
0-10	198.5
10-20	766.6
20-30	1626
30-40	2663
40-50	3756
50-60	4791
60-70	5667
70-80	6305
80-90	6650
90-100	6732
100-110	6819
110-120	6951
120-130	7108
130-140	7235
140-150	7307
150-160	7338
160-170	7349
170-180	7351
UNIT: lm	

Luminance cd/(m2)

G(DEG)	C0/180	C90/270
85	56718	7419
80	37914	10508
75	31404	12596
70	28323	14056
65	26049	15130
60	24546	15981
55	23458	16667
50	22655	17309
45	22163	17901

T-Grid Linear

Recessed | Architectural LED Linear

DISTRIBUTION DIAGRAM

2' : 15/16" Flat

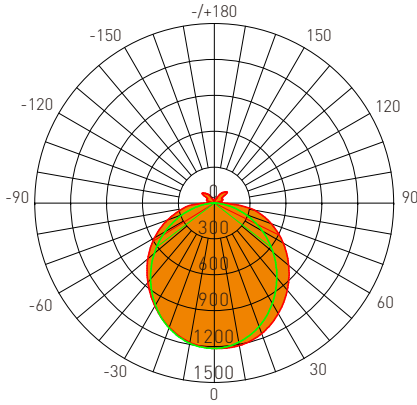

Test Number: TB2-DM-35U
 Lumens: 3929.5 Lm
 Watts: 30 W
 LPW: 130.98 Lm/W
 CCT: 3500K

UNIT: cd
 — CD/180,121.7
 — C90/270,104.7

Zonal Flux Diagram

τ	C0	C45	C90	C135	C180
10	1209	1197	1182	1179	1183
20	1160	1135	1097	1100	1106
30	1069	1032	969.8	981.5	994.4
40	949.8	897.5	813.5	838.9	865.9
50	812.1	745.3	642.4	684.7	726.7
60	665.0	586.4	462.4	525.3	577.4
70	507.6	421.5	279.9	359.8	418.5
80	337.4	255.9	106.9	201.9	266.4
90	70.64	54.47	7.822	52.54	64.96
100	6.505	14.63	1.276	15.31	7.789
110	73.37	49.46	8.152	47.50	68.83
120	74.42	99.24	8.385	95.48	69.09
130	141.6	94.10	4.775	82.93	130.5
140	117.7	68.19	4.555	63.01	104.1
150	75.28	39.68	4.531	41.25	69.66
160	32.87	29.51	4.638	25.03	26.27
170	12.04	11.16	5.354	8.723	9.498
180	5.843	6.003	5.683	6.647	5.171
DEG	LUMINOUS INTENSITY:cd				

Zonal Lumens

τ	φ total
0-10	114.8
10-20	442.4
20-30	935.1
30-40	1525
40-50	2139
50-60	2708
60-70	3174
70-80	3494
80-90	3642
90-100	3675
100-110	3709
110-120	3761
120-130	3824
130-140	3879
140-150	3911
150-160	3924
160-170	3929
170-180	3929
DEG	UNIT: lm

Luminance cd/(m2)

G(DEG)	C0/180	C90/270
85	22893	4464
80	19432	6155
75	16424	7374
70	14844	8184
65	13906	8764
60	13303	9246
55	12894	9636
50	12636	9993
45	12484	10320

4' : 15/16" Flat

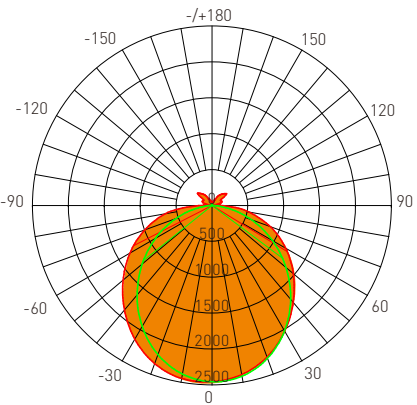

Test Number: TB4-DM-35U
 Lumens: 7877.7 Lm
 Watts: 60 W
 LPW: 131.30 Lm/W
 CCT: 3500K

UNIT: cd
 — CD/180,121.3
 — C90/270,104.4

Zonal Flux Diagram

τ	C0	C45	C90	C135	C180
10	2392	2411	2415	2440	2446
20	2246	2270	2264	2324	2343
30	2024	2042	2020	2117	2152
40	1760	1749	1705	1842	1900
50	1480	1431	1346	1526	1617
60	1185	1104	969.9	1200	1318
70	869.2	763.0	588.5	856.8	998.9
80	518.9	435.3	227.8	515.9	659.8
90	118.9	97.66	10.90	105.9	139.6
100	16.83	26.28	10.90	25.35	15.79
110	144.9	87.28	9.517	85.58	140.5
120	141.5	184.0	6.146	180.9	141.7
130	262.5	157.3	6.719	165.4	267.7
140	206.3	114.7	7.622	125.7	214.2
150	132.2	66.79	8.359	88.85	145.4
160	56.40	46.52	8.359	58.15	61.68
170	22.69	20.41	10.74	24.82	26.87
180	8.597	9.841	12.29	10.70	9.323
DEG	LUMINOUS INTENSITY:cd				

Zonal Lumens

τ	φ total
0-10	232.2
10-20	895.5
20-30	1984
30-40	3088
40-50	4326
50-60	5470
60-70	6405
70-80	7042
80-90	7329
90-100	7389
100-110	7456
110-120	7556
120-130	7675
130-140	7780
140-150	7841
150-160	7868
160-170	7876
170-180	7878
DEG	UNIT: lm

Luminance cd/(m2)

G(DEG)	C0/180	C90/270
85	37355	9611
80	29897	13118
75	26506	15533
70	25426	17208
65	24387	18425
60	23713	19399
55	23266	20203
50	23035	20947
45	22937	21625