



Appendix A

Vizion PMA Autopilot 172 Installation

**RESTRICTION ON USE, DUPLICATION, OR DISCLOSURE OF
PROPRIETARY INFORMATION**

THIS DOCUMENT CONTAINS PROPRIETARY INFORMATION OF TRUTRAK FLIGHT SYSTEMS, INC. AND MAY NOT BE REPRODUCED, COPIED, DISCLOSED OR UTILIZED IN ANY WAY, IN WHOLE OR IN PART, WITHOUT THE PRIOR WRITTEN CONSENT OF TRUTRAK FLIGHT SYSTEMS, INC.

Prepared by

TruTrak Flight Systems, Inc.

	Function/Title	Name
Prepared by	Engineering	Zach Williamson
Prepared by	President	Andrew Barker
Checked by	GM	Moss Foster
Approved by	President	Andrew Barker



Table of Contents

1. Document Revision History	3
2. Cessna 172 Roll Servo Installation.....	4
2.1. Materials List.....	4
2.2. Roll Servo Mounting Instructions	5
2.3. Cessna 172 F – S Vizion Roll IPC.....	17
3. Cessna 172 F – 172R Pitch Servo Installation	18
3.1. Pitch Servo Mounting Materials List.....	18
3.2. Pitch Servo Mounting Instructions.....	19
3.3. Cessna 172 F – S Vizion Pitch IPC.....	30
4. Cessna 172 F – 172 R Controller / Wiring Harness Installation	32
4.1. Wiring Harness Materials List.....	32
4.2. Wiring Harness / Controller Mounting Instructions	33
4.3. Cessna 172 F – S Vizion Wiring Harness IPC.....	46
5. Cessna 172 F – 172 R Autopilot Settings	48
5.1. Lateral Autopilot Settings.....	48
5.2. Vertical Autopilot Settings	49



1. Document Revision History

Rev	Description	Pages	Date
Prelim	Preliminary manual created	39	2-8-17
Rev A	Adjusted pitch installation to accommodate trim sensor	44	6-15-17
Rev B	Corrected rivet part numbers (pages 4, 17)	44	6-19-17
Rev C	Added Placard information (pages 28, 29, 41)	44	7-12-17
Rev D	Added 24 Volt Servo option and added installation clarification to pages 10,11,12,15,16,17,27,28, and 41.	44	9-6-17
Rev E	Added alternate pitch servo connection to yoke (pages 18, 25, 26, 27)	45	10-27-17
Rev F	Added MAC setting to autopilot setup page 43	45	11-2-17
Rev G	Added Pitch, Roll, and wiring IPC and pitch wiring option. Pages 17, 30, 37, 46	50	1-8-18

2. Cessna 172 Roll Servo Installation

2.1. Materials List

- 1 ea. 60 inch/lb PMA servo, TruTrak P/N 8100-064
- OR
- 1ea. 60 inch/lb 24 Volt PMA servo, TruTrak P/N 8100-065

- 1 ea. Cessna 172 Upper Roll Bracket, Trutrak P/N 1450-107
- 1 ea. Cessna 172 Lower Roll Bracket, Trutrak P/N 1450-108
- 1 ea. Cessna 172 Roll Inboard Pushrod, Trutrak P/N 7200-088
- 1 ea. Cessna 172 Roll Outboard Pushrod, Trutrak P/N 7200-090
- 1 ea. Cessna 172 Roll Servo Arm, Trutrak P/N 7200-091
- 1 ea. Servo Bolt Pattern Plate, TruTrak P/N 1420-216
- 3 ea. 8-32 x 3/8 Flat Head Socket Cap Screw SS, Trutrak P/N 2500-216
- 2 ea. MM-3-300 Rod End Bearing, Trutrak P/N 2510-051
- 2 ea. AN345-10 nut
- 7 ea. AN526C-832R8 Screw
- 7 ea. MS21051-08 Anchor Nut
- 14 ea. MS20426AD3-4 Rivet
- 4 ea. AN3-3A Bolt
- 1 ea. AN3-14A Bolt
- 3 ea. AN3-7A Bolt
- 4 ea. MS35333-39 Internal Lock Washer
- 4 ea. AN960-10 Washer
- 2 ea. AN970-3 Washer
- 2 ea. MS20364-1032 Nut

2.2. Roll Servo Mounting Instructions

1. The roll servo will be mounted in the right wing just forward of the inboard end of the aileron.
 - 1.1. Begin by removing the inspection cover on the lower wing skin located forward of the inboard end of the aileron.
 - 1.2. Figure 2-1 shows the roll servo mounting location from above the right wing and figure 2-2 shows the mounted servo in the wing.
- 1.3. **NOTE: Apply torque seal to all bolts after final torquing is achieved.**



Figure 2-1



Figure 2-2

2. The Cessna 172 Upper Roll Bracket (P/N 1450-107) will be mounted to the flange of the rear wing spar using 3 ea. AN526C-832R8 screws.
 - 2.1. Locate the inboard screw hole as shown in figure 2-3 on the upper wing skin.
 - 2.2. Drill the inboard hole only at this time with a #19 drill.

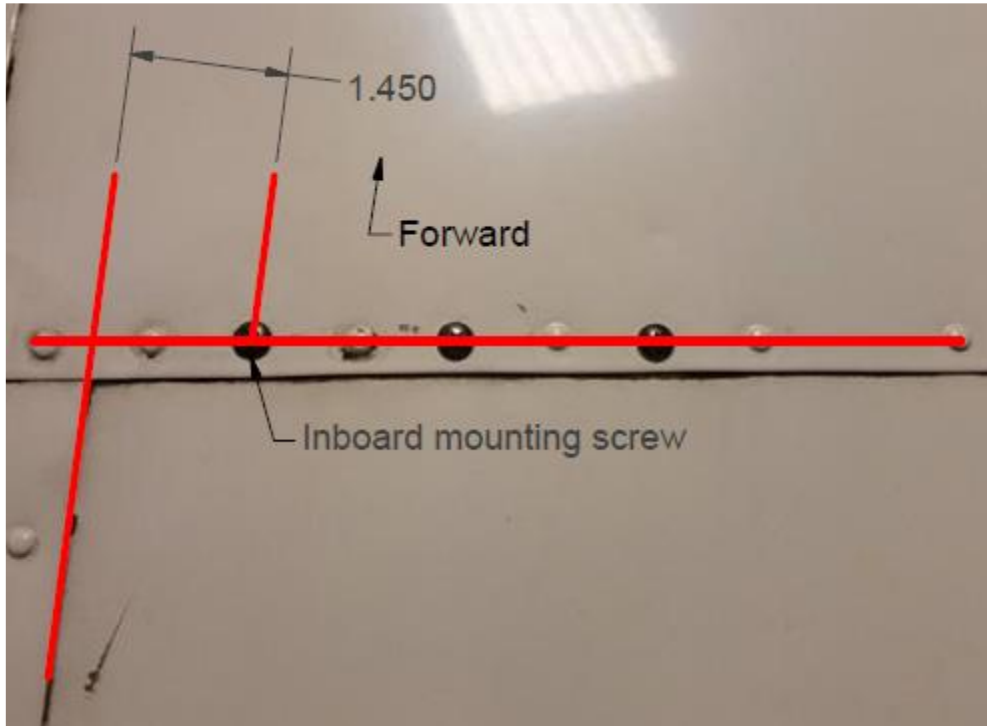

Figure 2-3

3. Drill Cessna 172 Upper Roll Bracket (P/N 1450-107) mounting holes.
 - 3.1. Place the upper roll servo bracket in the wing and temporarily attach the bracket using a cleco in the previously drilled hole.
 - 3.2. Rotate the bracket so that the outboard hole is aligned with the row of rivets in the spar flange.
 - 3.3. Use a right angle drill to match drill the outer screw hole from inside the wing.
 - 3.4. Use a cleco to temporarily attach the outer screw hole and then match drill the center screw hole on the top bracket to the spar flange.

4. Install anchor nuts in Cessna 172 Upper Roll Bracket (P/N 1450-107)
 - 4.1. Remove the bracket from the aircraft.
 - 4.2. Rivet 3 ea. MS21051-08 anchor nuts in place using 6 ea. MS20426AD3-4 rivets as shown in figure 2-4.

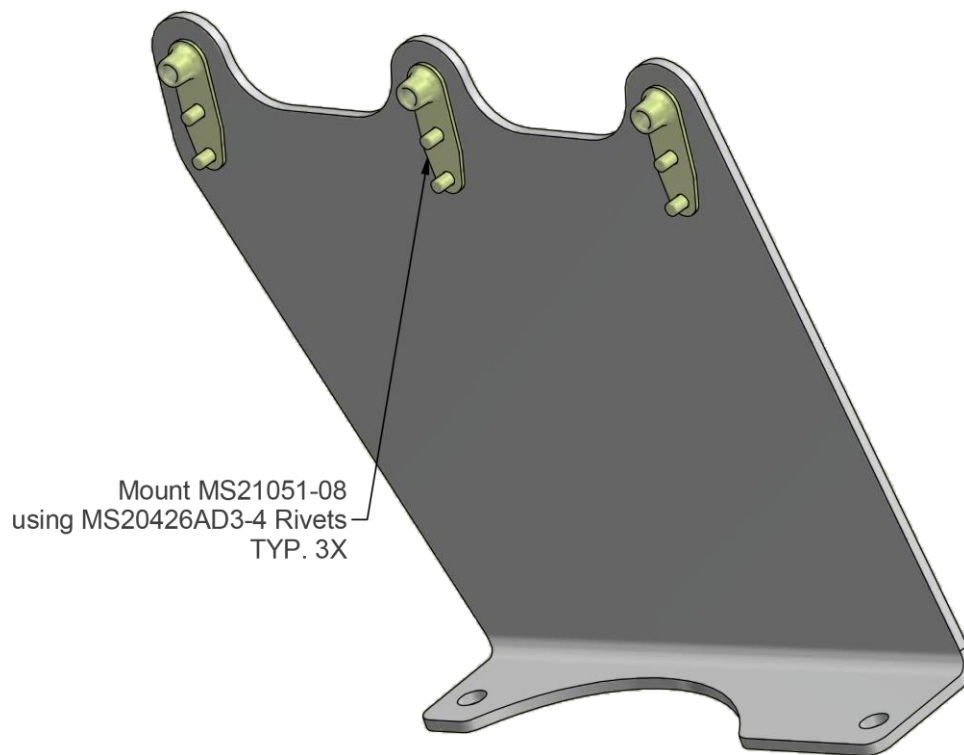

Figure 2-4

5. Install and temporarily assemble Cessna 172 Upper Roll Bracket (P/N 1450-107), Servo Bolt Pattern Plate (P/N 1420-216), and Cessna 172 Lower Roll Bracket, (P/N 1450-108)
- 5.1. Attach the Cessna 172 Upper Roll Bracket (P/N 1450-107) to the upper spar flange using 3 ea. AN526C-832R8 screws.
 - 5.1.1. **Ensure that screws are tight, as this part will not be removed after this step!**
- 5.2. Temporarily attach the Servo Bolt Pattern Plate (P/N 1420-216) to the upper bracket using 2 ea. AN3-3A as shown in figure 2-5.
- 5.3. Temporarily attach the Cessna 172 Lower Roll Bracket, (P/N 1450-108) to the Servo Bolt Pattern Plate (P/N 1420-216) using 2 ea. AN3-3A as shown in figure 2-5.

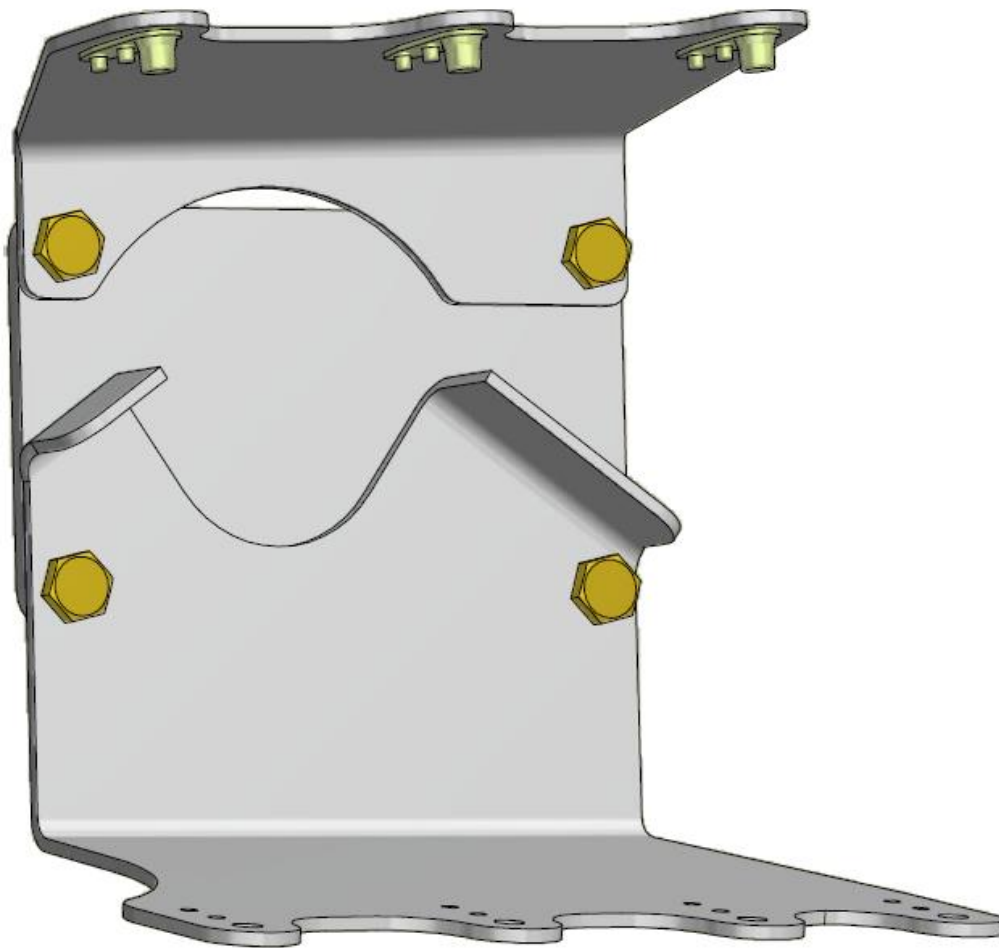

Figure 2-5

6. Drill Cessna 172 Lower Roll Bracket, (P/N 1450-108) mounting holes.
 - 6.1. Align the lower bracket mounting holes with row of rivets on the lower spar flange.
 - 6.2. Match drill the outboard mounting hole using a #19 bit.
 - 6.3. Secure the outboard hole with a cleco.
 - 6.4. Match drill the remaining 3 holes on Cessna 172 Lower Roll Bracket, (P/N 1450-108), installing a cleco after each hole is drilled.

NOTE: Do not install the bracket until step 13.

7. Install anchor nuts in Cessna 172 Lower Roll Bracket (P/N 1450-108)
 - 7.1. Remove Servo Bolt Pattern Plate (P/N 1420-216), and Cessna 172 Lower Roll Bracket, (P/N 1450-108))
 - 7.2. Rivet 4 ea. MS21051-08 anchor nuts in place using 8 ea. MS20426AD3-4 rivets as shown in figure 2-6.

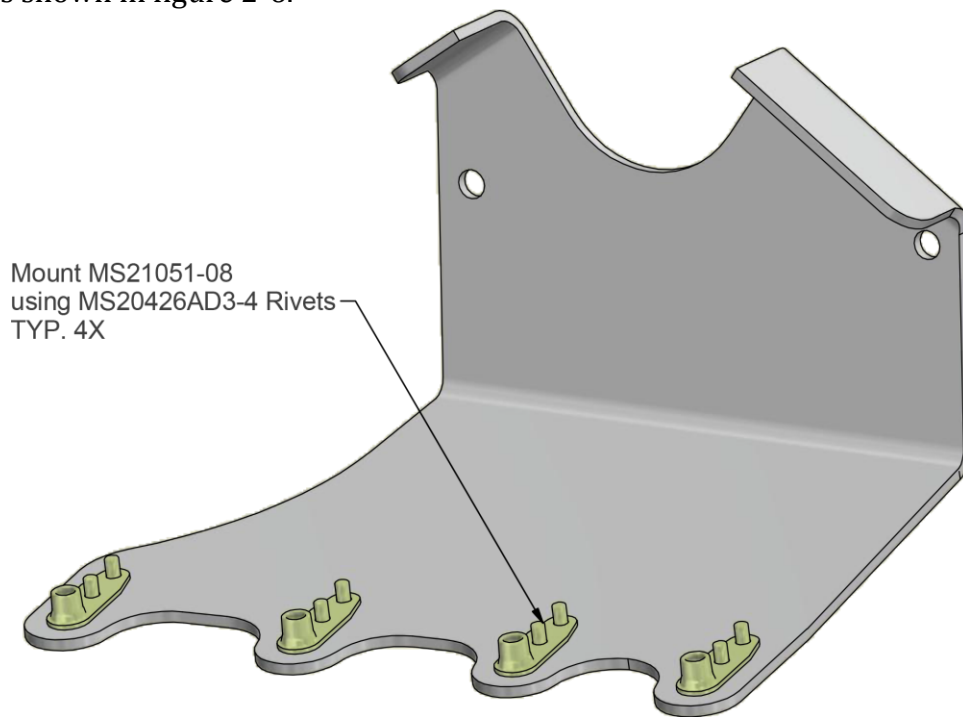

Figure 2-6

8. Install and assemble the Cessna 172 Roll Inboard Pushrod (P/N 7200-088) and Cessna 172 Outboard Pushrod (P/N 7200-090). Figure 2-7 shows the assembled joint of these two parts.
 - 8.1. Verify that Cessna 172 Roll Inboard Pushrod, Cessna 172 Outboard Pushrod, and AN3-7A bolts all mate properly prior to inserting parts through inspection hole.
 - 8.2. Ensure that both threaded inserts are free of burrs and rod end bearings can be properly inserted.
 - 8.3. Slide the Cessna 172 Roll Inboard Pushrod (P/N 7200-088) through the inspection hole toward the cabin until the pushrod is entirely in the wing.
 - 8.4. Make sure that the 10-32 threaded insert is toward the cabin and the cross drilled insert is outboard.
 - 8.5. Place the Cessna 172 Outboard Pushrod (P/N 7200-090) through the inspection hole with the 10-32 threaded insert outboard.
 - 8.6. Align the cross bolt holes and slide the inner and outer pushrods together.
 - 8.7. Bolt the sections together using 2 AN3-7A bolts and MS20364-1032 nuts torqued to 20-25 in-lb.
 - 8.8. Apply torque seal to this assembly at this point, as it is difficult to reach once attached to servo and bellcrank.
 - 8.9. Remove the aileron bellcrank inspection panel and slide the assembled pushrod outward until it reaches the aileron bellcrank.

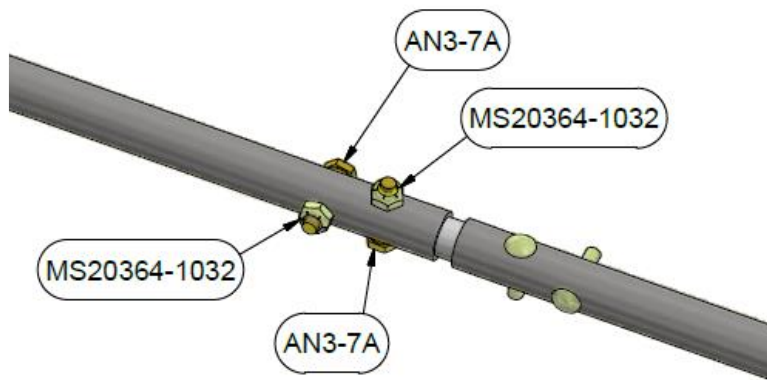

Figure 2-7

9. Attach rod end bearing to bellcrank.

- 9.1. Remove the rear aileron bellcrank cable attachment bolt and replace with an AN3-14A , MM-3-300, 2 ea. AN960-10, and AN970-3 washer as shown in figure 2-8.
- 9.2. Torque bolt to 20-25 in-lb.
- 9.3. Verify that the feel of the controls in roll have not changed as this could indicate that a control cable has come off of the pulley. This bolt replacement should be able to be accomplished without re-tensioning the aileron control cables.

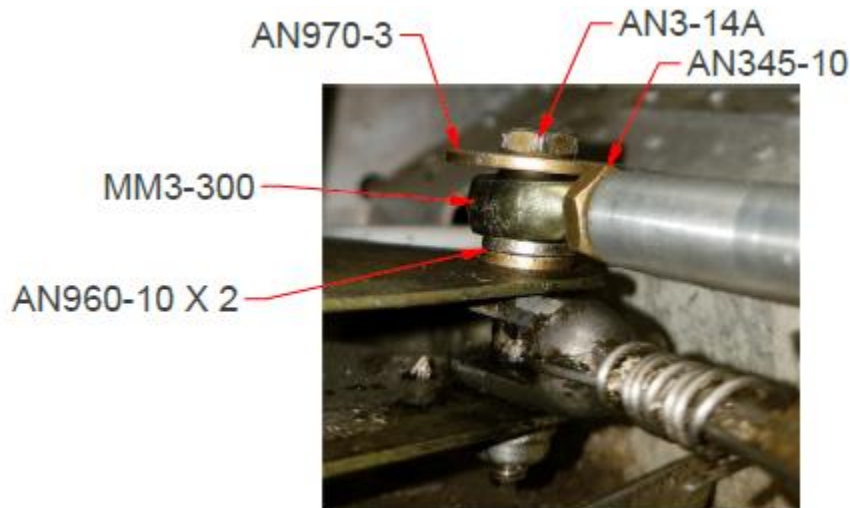

Figure 2-8

10. Attach assembled pushrod to bellcrank rod end bearing.

- 10.1. Fully thread an AN345-10 nut on both MM-3-300 rod end bearings and start threading the pushrod assembly to the outer rod end bearing.
11. Assemble Cessna 172 Roll Servo Arm (P/N 7200-091) and 60 inch/lb PMA servo (P/N 8100-064).
- 11.1. Attach the Cessna 172 Roll Servo Arm (P/N 7200-091) to the 60 inch/lb PMA servo (P/N 8100-064 for 12 volt or P/N 8100-065 for 24 volt) using the provided 8-32 x 3/8" flat head screws.
 - 11.2. Use blue threadlocker (Loctite 242 or equivalent) and torque the screws to 18-20 in-lb.

12. Roll servo installation should be paused at this step, and continued once the wiring is installed per section 4.
13. Install Cessna 172 Lower Roll Bracket, (P/N 1450-108) and 60 inch/lb PMA servo (P/N 8100-064 for 12 volt or P/N 8100-065 for 24 volt).
 - 13.1. Place the lower roll servo bracket in the wing and start 4 AN526C-832R8 screws but leave the screws loose so that the lower bracket can still move.
 - 13.2. Attach the electrical connector to the roll servo and secure it in place with the mounting screws.
 - 13.3. Place the servo behind the mounting bracket with the arm oriented between the servo stops as shown in figure 2-9.
 - 13.4. Start the 2 AN3-3A bolts with MS35333-39 lock washers and blue threadlocker (Loctite242 or equivalent) in the upper servo mounting holes then start the lower mounting bolts in the same manner.
 - 13.5. Finally torque the 4 servo mounting bolts to 20-25 in-lb and tighten the lower bracket mounting screws to the spar flange. Figure 2-10 shows the 4 screws in the lower spar flange.

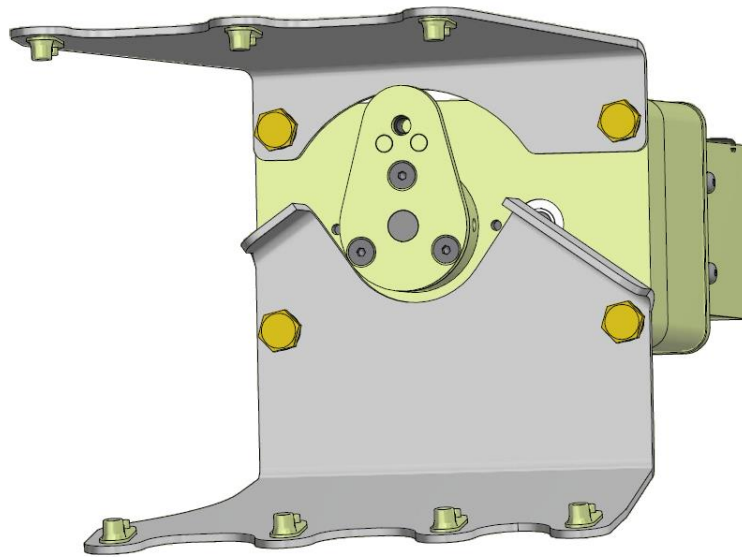

Figure 2-9



Figure 2-10



14. Install servo side rod end bearing in push rod assembly.

- 14.1. Have an assistant hold the yoke in the full left position and rotate the servo arm against the outboard stop as shown in figure 2-11.
- 14.2. Thread the MM-3-300 rod end bearing into the servo end of the pushrod until the pushrod is the correct length to align with the drive point on the servo arm. The pushrod must be positioned aft of the rear aileron control cable at the servo and above the control cable at the aileron bellcrank.
- 14.3. Verify that the control cable is not twisted around the pushrod.

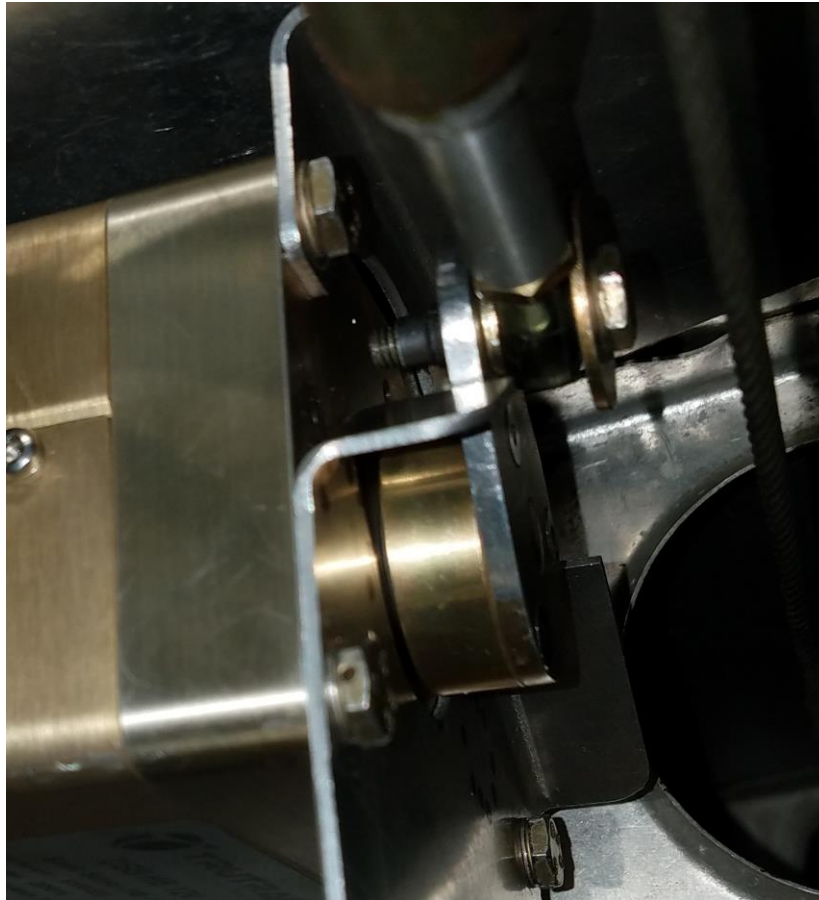

Figure 2-11

15. Attach the pushrod assembly to the Cessna 172 Roll Servo Arm (P/N 7200-091).
 - 15.1. Attach the pushrod with hardware as shown in figure 2-12 and torque to 20-25 in-lb.
 - 15.2. Rotate the pushrod until the rod end bearings on each end are threaded in equally then tighten the jam nuts to 20-25 in-lb.
 - 15.3. Move the yoke throughout the full range of travel and check for binding in the rod end bearings. If binding exists adjust the rod end bearings and jam nuts to eliminate it.
 - 15.4. Ensure that aircraft stops are contacted prior to servo stops. Adjust length of pushrod as needed until servo stops are not contacted when controls are moved to both ends of travel.**

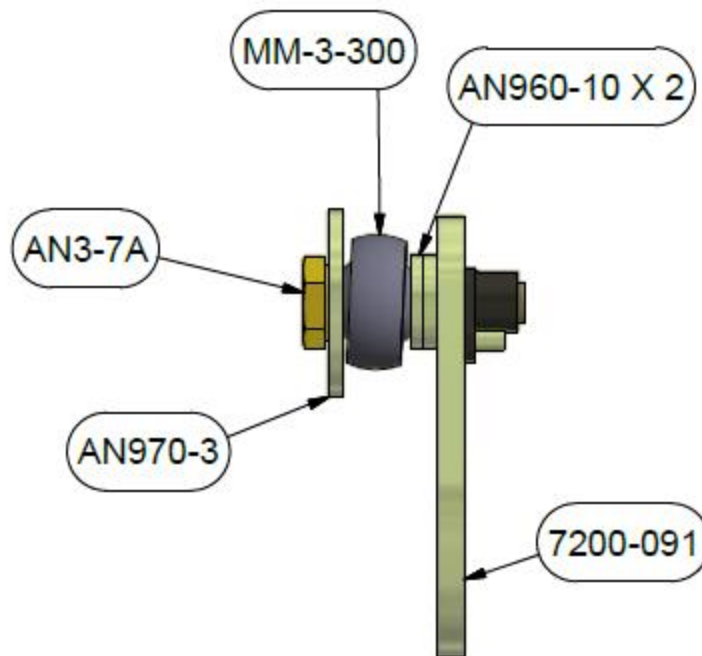
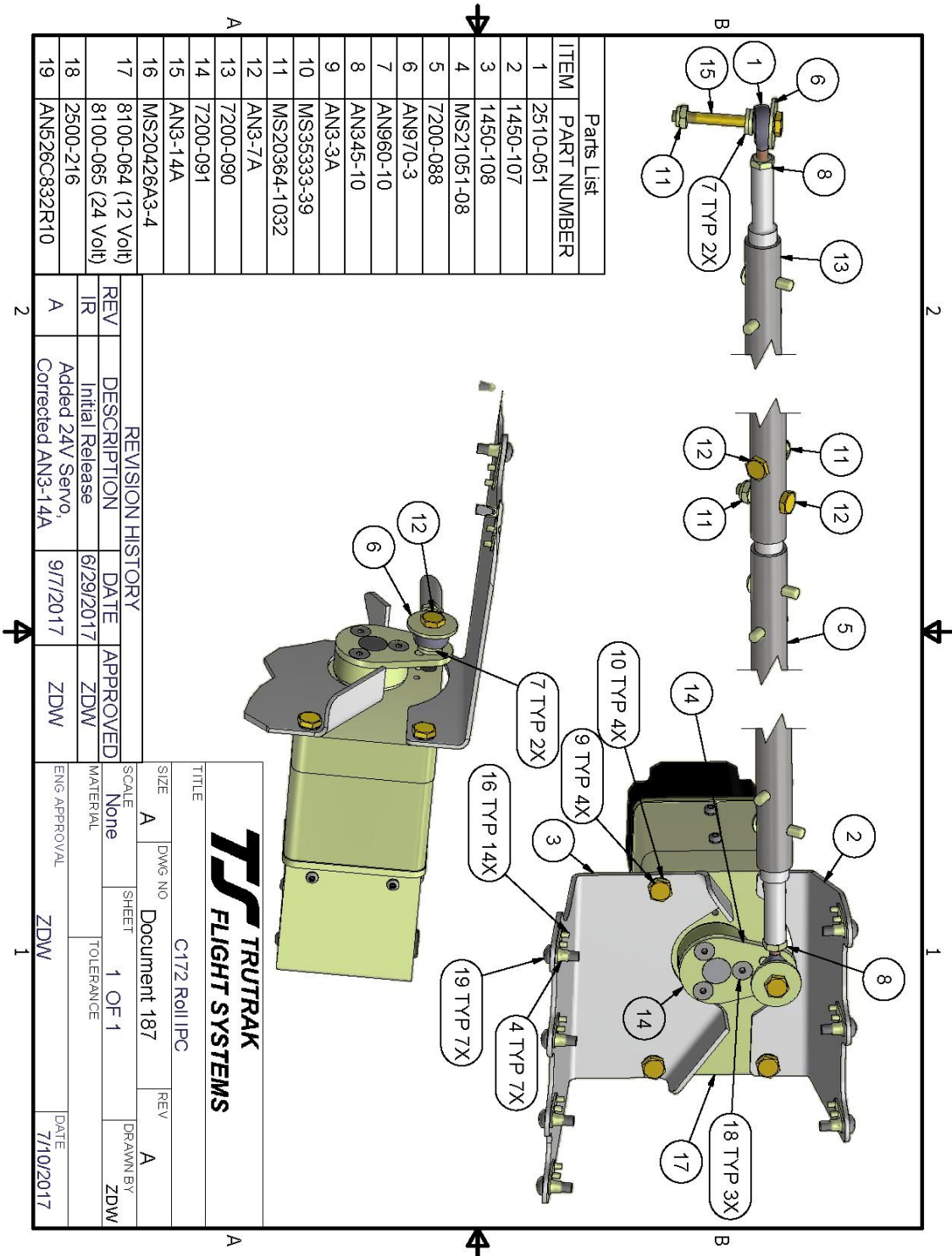

Figure 2-12

16. Verify that the servo and pushrod motion are unobstructed throughout the full control travel. Once wiring harness is installed, ensure that the wiring harness is properly secured to prevent interference.
- 17. Apply torque seal to all bolts after final torquing is achieved.**

2.3. Cessna 172 F - S Vizion Roll IPC



3. Cessna 172 F – 172R Pitch Servo Installation

3.1. Pitch Servo Mounting Materials List

- 1 ea. 60 inch/lb PMA servo, TruTrak P/N 8100-064
- OR
- 1ea. 60 inch/lb 24 Volt PMA servo, TruTrak P/N 8100-065

- 1 ea. Cessna 172 Late Model Pitch Bracket, Trutrak P/N 1450-109
- 1 ea. Cessna 172 Late Model Pitch Servo Stop, Trutrak P/N1450-110
- 2 ea. Cessna 172 Late Model Pitch Clamp Half, Trutrak P/N 1420-208
- 1 ea. Cessna 172 Late Model Pitch Servo Arm, Trutrak P/N 1420-209
- 1 ea. PMA Link Sensor, Trutrak P/N 8000-177
- 1 ea. Microfit 6 Position Cable 500MM, Trutrak P/N 6000-061
- 2 ea. 3/16" Bore Large Male Rod End Bearing, Trutrak P/N 2510-052
- 3 ea. 8-32 x 3/8 Flat Head Socket Cap Screw SS, Trutrak P/N 2500-216
- 2 in. MS22529/2-1R Grommet Edging
- 4 ea. MS3367-1-0 Cable Tie
- 6 ea. 10-32 Anchor Plate MS21047-3 OR use appropriate floating nutplates
- 12 ea. Rivet MS20426AD3-5
- 10 ea. MS35333-39 Internal Lock Washer
- 10 ea. AN3-3A Bolt
- 2 ea. AN315-4 1/4-28 Nut
- 4 ea. MS20364-1032 Nut
- 2 ea. AN3-11A Bolt
- 1 ea. AN3-10A Bolt
- 1 ea. AN3-22A Bolt
- 6 ea. AN960-10 Washer
- 2 ea. AN970-3 Washer
- 1 ea. AN3-23A Bolt

3.2. Pitch Servo Mounting Instructions

1. The pitch servo will be mounted under the instrument panel between the rudder pedals as shown in figure 3-1.

1.1. NOTE: Apply torque seal to all bolts after final torquing is achieved.



Figure 3-1

2. Drill holes for mounting of Cessna 172 Late Model Pitch Bracket, (P/N 1450-109)
 - 2.1. Remove the cover plate that attaches to the top of the center tunnel.
 - 2.2. Drill, countersink and debur the center tunnel flanges as shown in figure 3-2.

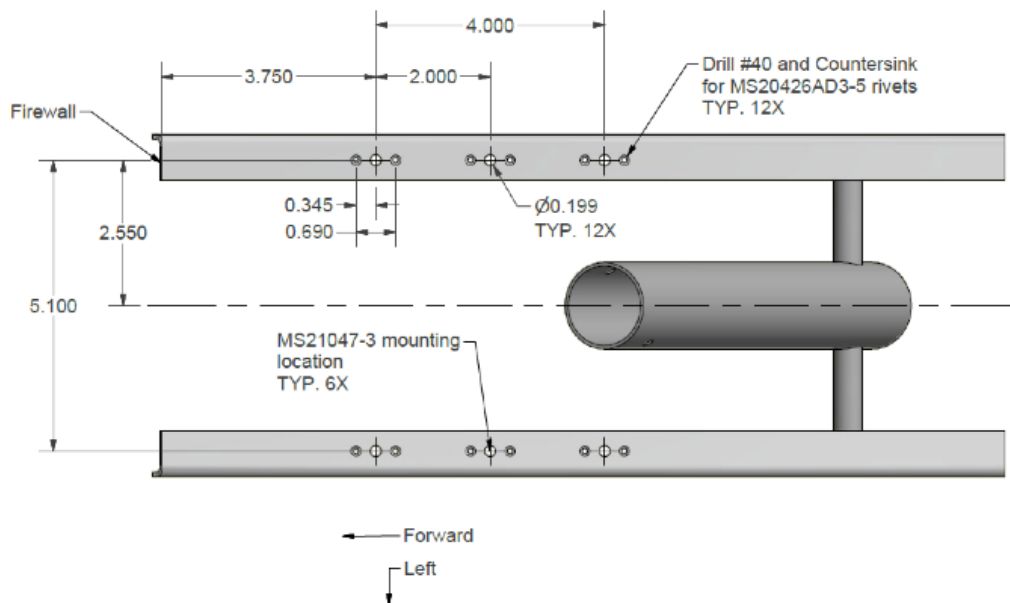

Figure 3-2

3. Install anchor plates in flanges of center tunnel.
 - 3.1. Rivet 6 ea. MS21047-3 anchor plates to the bottom side of the servo flanges using 12 ea. MS20426AD3-5 rivets as shown in Figure 3-3.

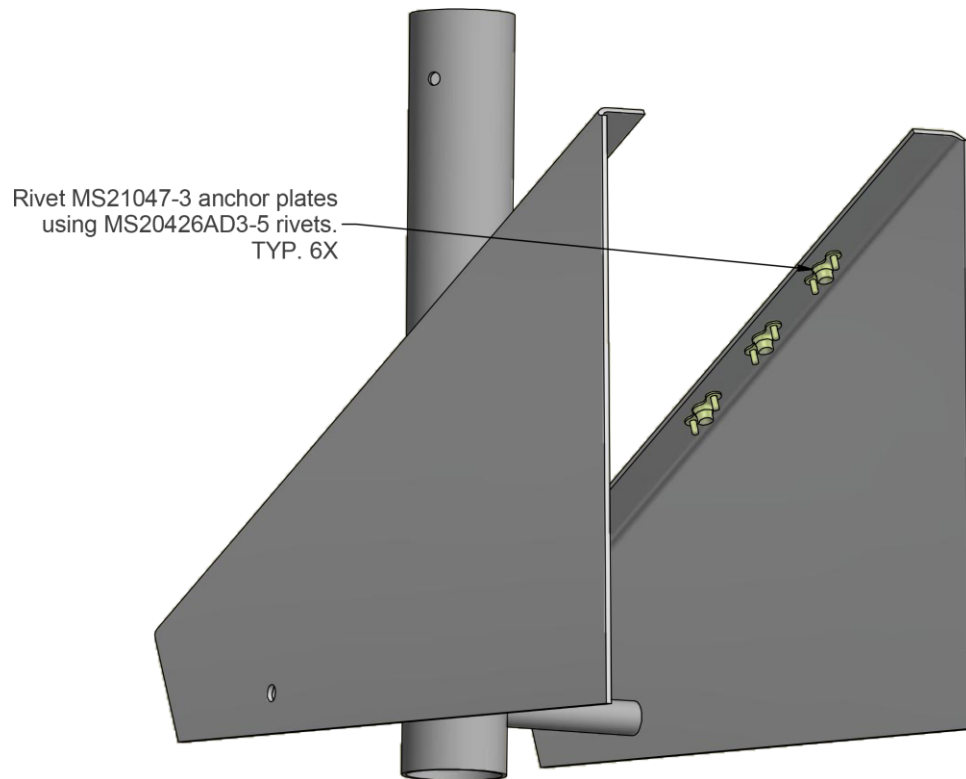

Figure 3-3

4. Assemble the 60 inch/lb PMA servo (P/N 8100-064 for 12 volt or P/N 8100-065 for 24 volt), Cessna 172 Late Model Pitch Servo Stop (P/N1450-110), and Cessna 172 Late Model Pitch Bracket (P/N 1450-109).
 - 4.1. Assemble using 4 ea AN3-3A bolts and MS35333-39 lock washers as shown in figure 3-4.
 - 4.2. Use blue threadlocker (Loctite 242 or equivalent) and torque the bolts to 20-25 in-lb.



Figure 3-4

5. Attach Cessna 172 Late Model Pitch Servo Arm (P/N 1420-209) to 60 inch/lb PMA servo (P/N 8100-064 for 12 volt or P/N 8100-065 for 24 volt). This assembly is shown in Figure 3-4 above.
 - 5.1. Assemble Cessna 172 Late Model Pitch Servo Arm (P/N 1420-209) and 60 inch/lb PMA servo (P/N 8100-064 for 12 volt or P/N 8100-065 for 24 volt) using the provided 8-32 x 3/8" flat head screws.
 - 5.2. The servo arm must be rotated so that it is between the servo stop.
 - 5.3. Use blue threadlocker (Loctite 242 or equivalent) and torque the screws to 18-20 in-lb.

6. Pitch servo installation should be paused at this step, and continued once the wiring is installed per section 4.
7. Connect wiring harness to 60 inch/lb PMA servo (P/N 8100-064 for 12 volt or P/N 8100-065 for 24 volt).
 - 7.1. Connect the pitch servo wiring harness connector to the servo and secure the connector screws.
 - 7.2. Connect one end of the Microfit cable (P/N 6000-061) to the corresponding servo connector.
 - 7.3. Install 2" of M22529/2-1R on the front left side of the servo bracket.
 - 7.4. Route the servo wiring harness forward around the left side of the servo bracket then secure the wiring to the servo bracket with 2 MS3367-1-0 cable ties in the provided slots.
 - 7.5. Route the Microfit cable aft of the servo toward the control yoke.
8. Attach servo bracket assembly to mounting flanges. Figure 3-5 and 3-6
 - 8.1. Attach the servo bracket assembly to the mounting flanges using 6 AN3-3A bolts and MS35333-38 lock washers.
 - 8.2. Torque bolts to 20-25 in-lb.



Figure 3-5



Figure 3-6

9. Begin installation of Cessna 172 Late Model Pitch Clamp Half (P/N 1420-208).
 - 9.1. Mark the control yoke 9" up from the center of the pivot point. This will be the location of the center of the clamp. Note the location where the yoke bends forward. If the bend is below the 9" mark follow the directions in 10.6.1. If the bend is above the 9" mark follow the directions in 10.6.2.

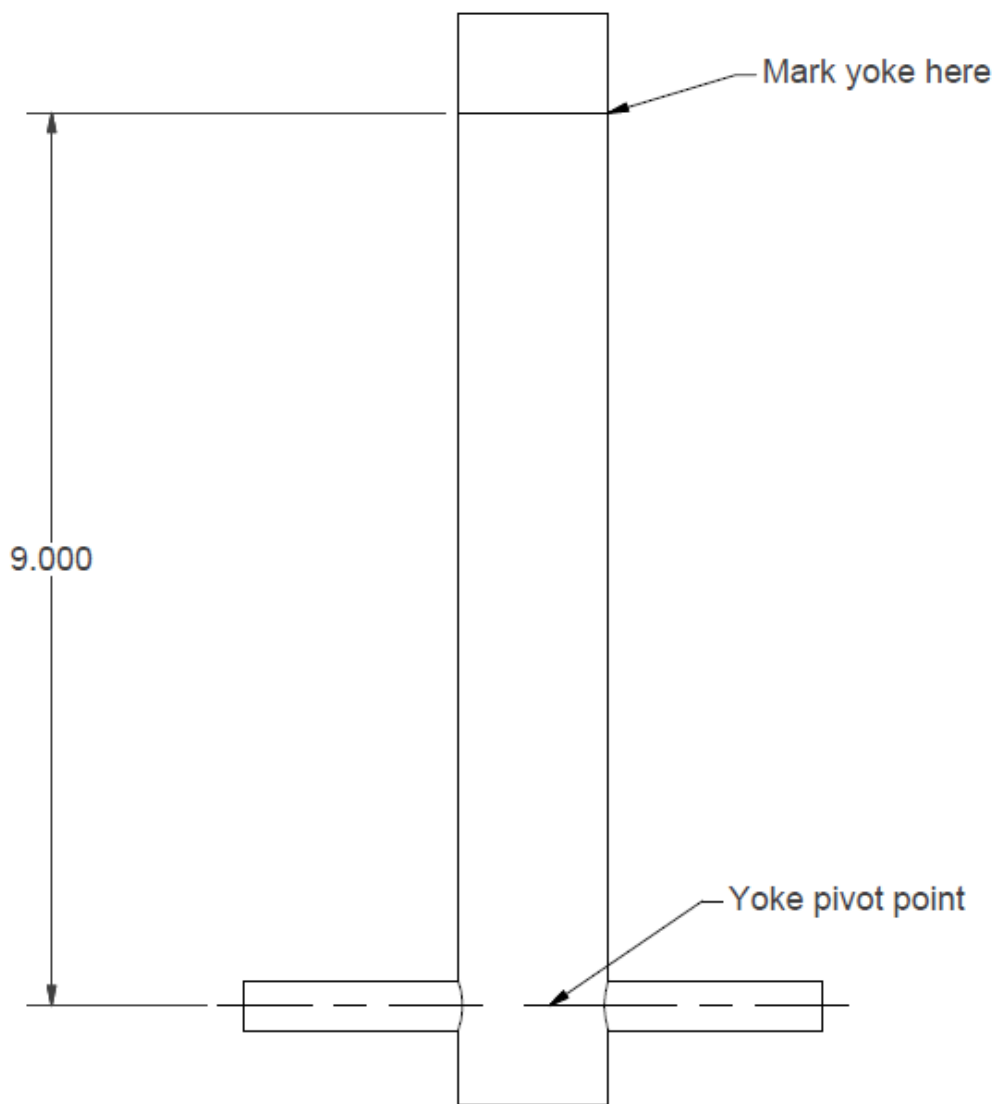

Figure 3-7

10. Assemble Cessna 172 Late Model Pitch Clamp Half (P/N 1420-208) (two parts) to yoke.
 - 10.1. Assemble the clamp as shown in figure 3-8 around the yoke tube.
 - 10.2. Align the center of the clamp with the mark made previously and the rod end bearing directly to the front of the aircraft.
 - 10.3. Tighten the forward AN3-11A bolt to 20-25 in-lb and then torque the rear bolt to 20-25 in-lb.
 - 10.4. With the clamp halves in place match drill a .199" hole in the yoke with the anti-rotation bolt holes in the clamp halves.
 - 10.5. Drill each side of the yoke tube using the clamps as a guide.
 - 10.5.1. **Do not attempt to drill through both walls of the tube from one side!**
 - 10.6. Final connection to yoke tube. See section 9.1
 - 10.6.1. Remove the clamp assembly from the yoke tube. Assemble as shown and torque to 20-25 in-lb.

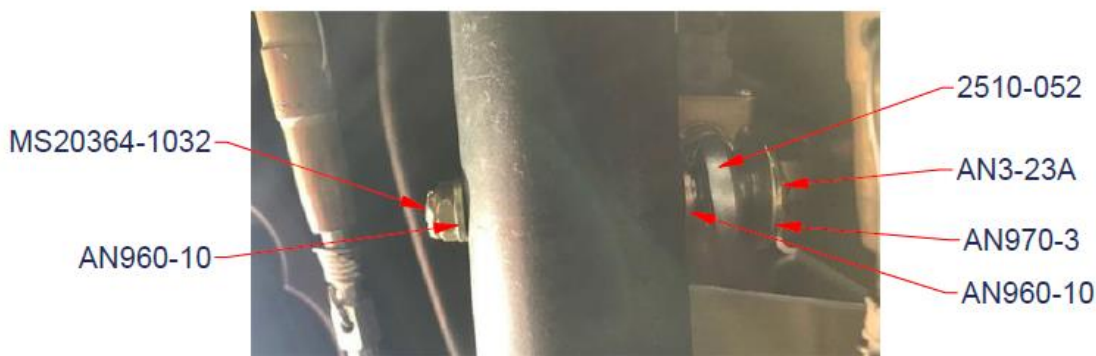

Figure 3-8



Figure 3-9

10.6.2. Place the AN3-22A bolt thru the assembly and torque to 20-25 in-lb.

Parts List	
ITEM	PART NUMBER
1	Control Yoke
2	1420-208
3	2510-052
4	MS20364-1032
5	AN960-10
7	AN3-22A
8	AN3-11A

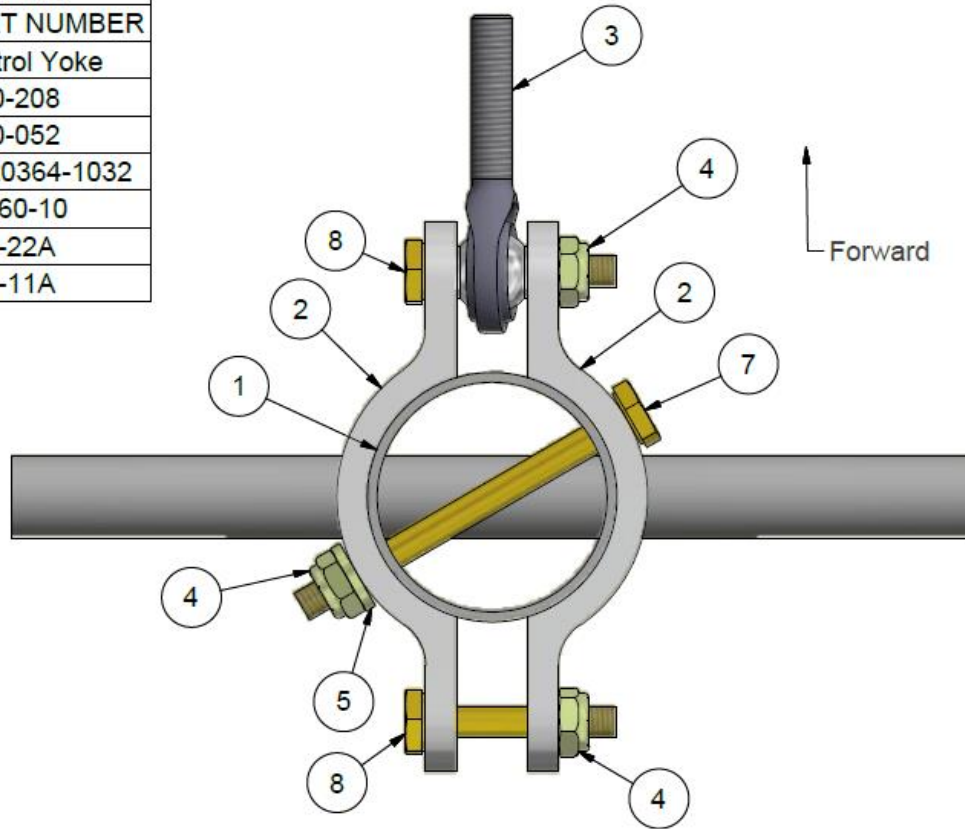

Figure 3-10

11. Assemble and install PMA link sensor (P/N 8000-177).
 - 11.1. Thread an AN315-4 nut approximately $\frac{3}{4}$ of the way down each rod end bearing.
 - 11.2. Hold the yoke in the full aft position and the servo arm against the rear servo stop.
 - 11.3. Thread both rod end bearings equally into the link sensor with the connector oriented upward and aft until the rod end bearing aligns with the outer hole in the servo arm. Figure 3-9 shows the fully assembled pitch servo, bracket, link sensor, and clamp.
 - 11.4. Fasten the rod end bearing to the servo arm using fasteners as shown in figure 3-11 and torque to 20-25 in-lb.

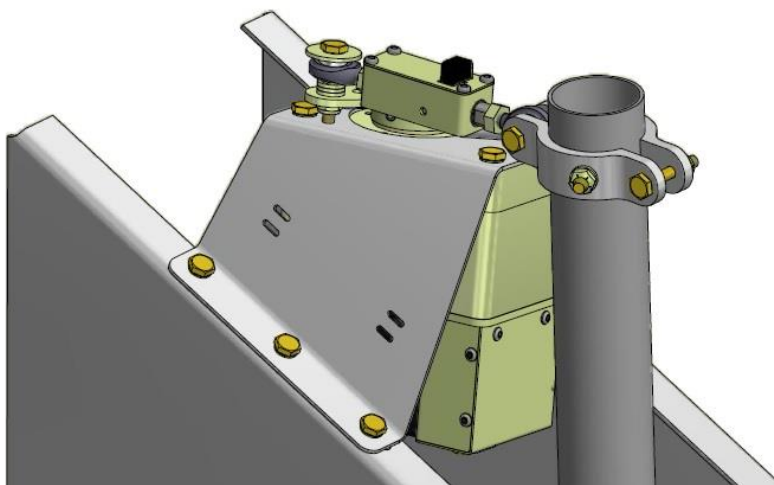

Figure 3-11

Parts List		
ITEM	QTY	PART NUMBER
1	1	1420-209
2	3	AN960-10
3	1	MS20364-1032
4	1	2510-052
5	1	2500-047
8	1	AN3-10A

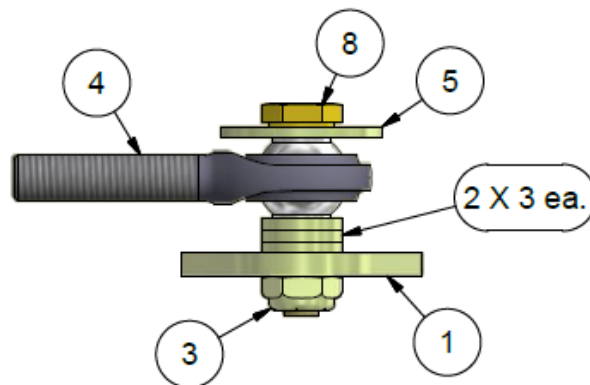
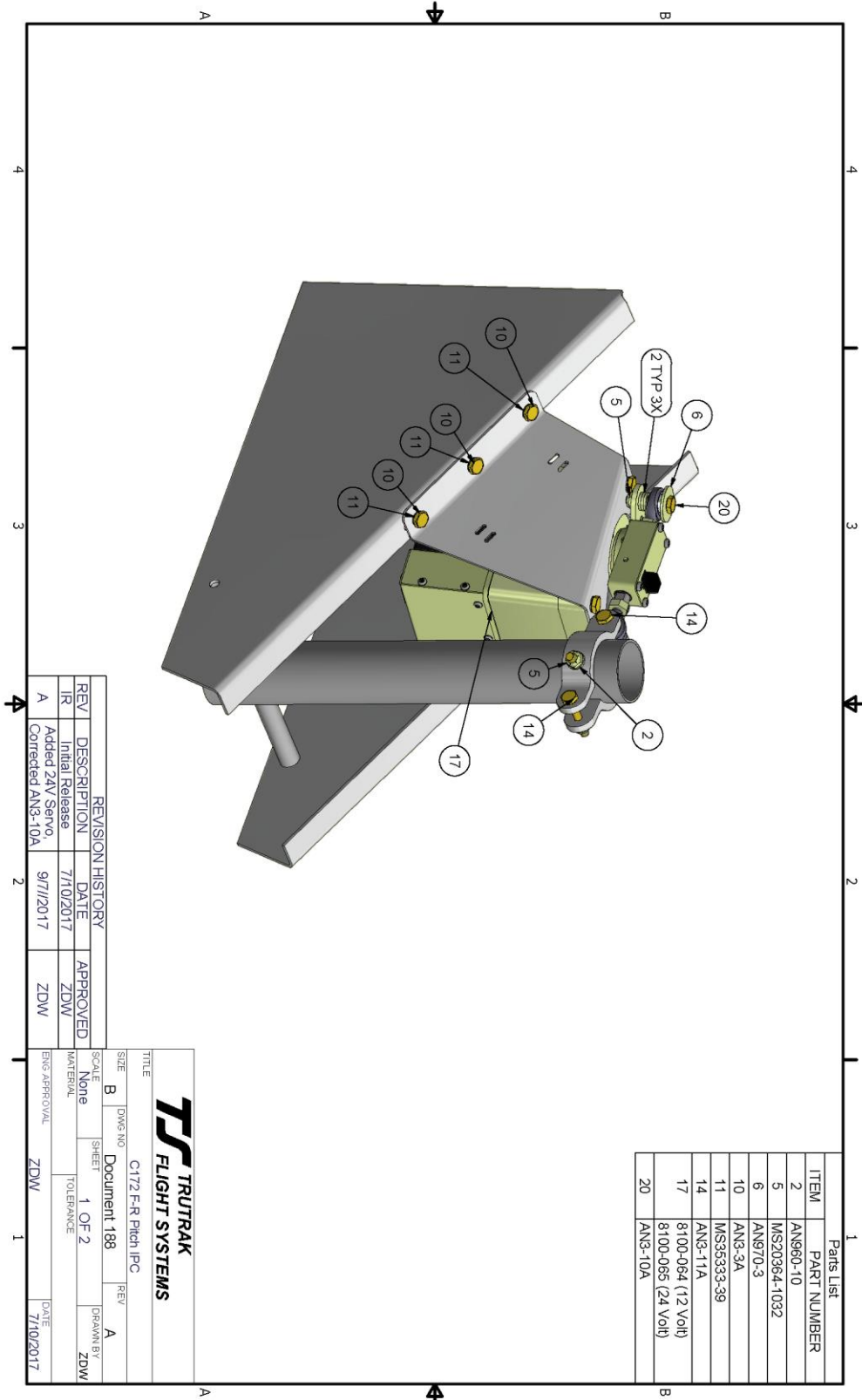

Figure 3-12



12. Finish PMA Link Sensor installation.
 - 12.1. With the link sensor centered on the rod end bearings torque the AN315-4 jam nuts to 30-40 in-lb against the link sensor. The link sensor connector must point upward.
 - 12.2. Route the Microfit cable up the control yoke and connect to the link sensor.
 - 12.3. Secure the Microfit cable to the control yoke with 2 MS3367-1-0 cable ties. Ensure that the cable has adequate strain relief at both ends throughout the full range of control yoke travel. Maintain adequate clearance between the cable and all moving parts.
 - 12.4. Move the yoke throughout the full range of travel and check for binding in the rod end bearings.
 - 12.5. If binding exists adjust the rod end bearings and jam nuts to eliminate it.
13. Verify that the servo and link sensor motion are unobstructed throughout the full control travel. Once installed, ensure that the wiring harness is properly secured to prevent interference.
14. **Apply torque seal to all bolts after final torquing is achieved.**

3.3. Cessna 172 F - S Vizion Pitch IPC



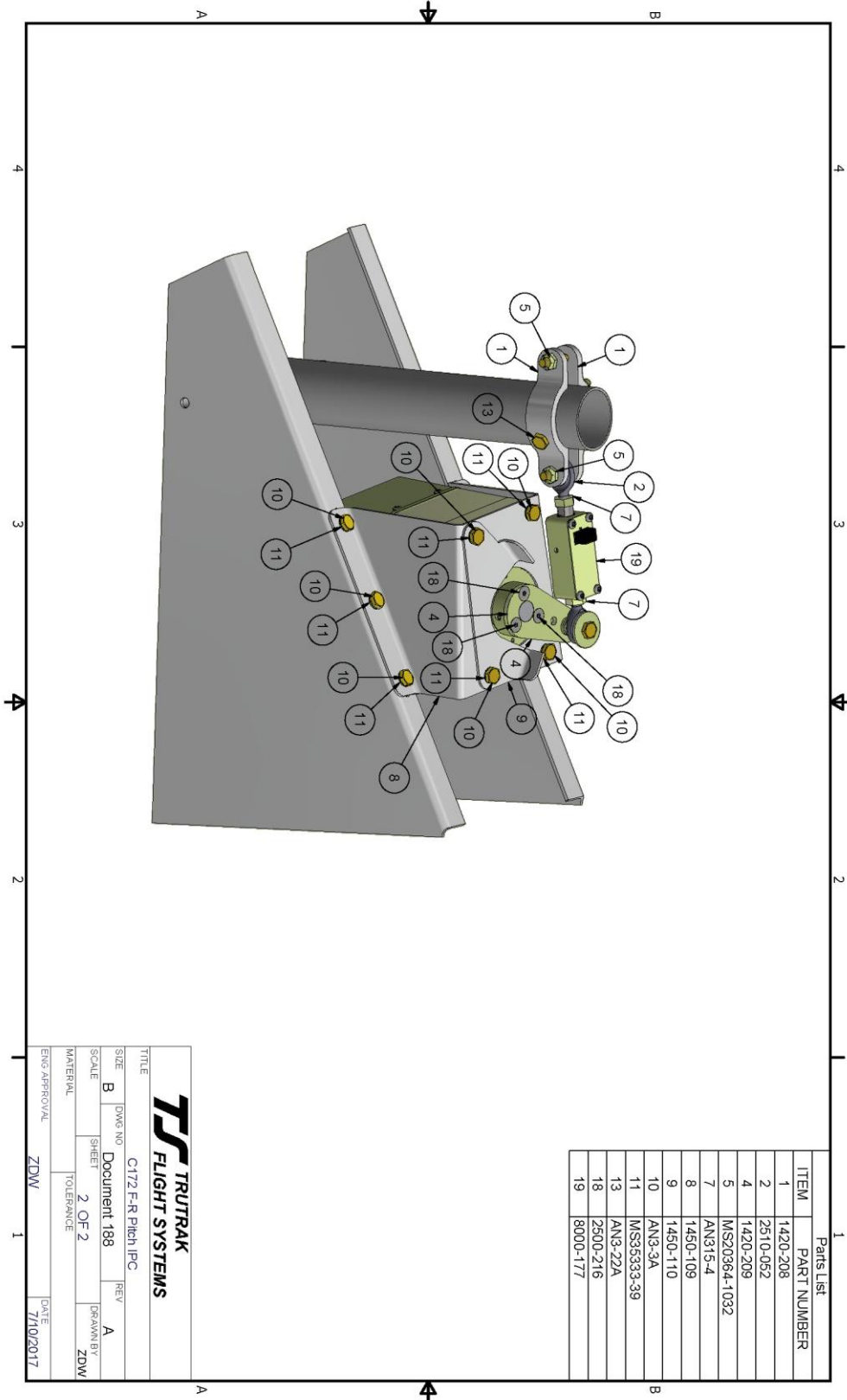

Parts List	
ITEM	PART NUMBER
1	1420-208
2	2510-052
4	1420-209
5	MS20364-1032
7	AN315-4
8	1450-109
9	1450-110
10	AN3-3A
11	MS35333-39
13	AN3-22A
18	2500-216
19	8000-177

TRU TRAK		FLIGHT SYSTEMS	
TITLE	C172 F-R Pitch IPC	REV	A
SIZE	B	DWG NO	Document 188
SCALE	2 OF 2	SHEET	2 OF 2
MATERIAL	TOLERANCE	DRAWN BY	ZDW
ENG. APPROVAL	ZDW	DATE	7/10/2017



4. Cessna 172 F – 172 R Controller / Wiring Harness Installation

4.1. Wiring Harness Materials List

- 1 ea. Cessna 172 Vizion Wiring Harness, Trutrak P/N 8220-031
- 1 ea. Vizion 2" Controller Trutrak P/N 8000-174 OR Vizion 3" Controller Trutrak P/N 8000-176 OR Vizion Flat Pack Controller Trutrak P/N 8000-175
- 25 ea. MS3367-1-0 Cable Tie
- 14 in. MS22529/2-1R Grommet Edging
- 1 ea. Vizion Emergency Level Button Kit, Trutrak P/N 8100-113
- 1 ea. Vizion Limitations Placard, Trutrak P/N 8300-092
- 1 ea. 5A AP circuit breaker (not supplied)
- 1 ea. Control Wheel Steering Switch (not supplied, but MUST be RED in color)
- 1 ea. AP Master Switch (not supplied)
- 4 ea. 6-32 X 3/8" Instrument mounting screw (not supplied)
 - Various terminals and pins for connection of power and GPS
 - 1/8"-27 NPT male fittings and tees for connecting the A/P pitot and static to the aircraft systems.

4.2. Wiring Harness / Controller Mounting Instructions

1. Begin by disconnecting the aircraft battery.
2. Select a mounting location for the autopilot controller.
 - 2.1. Consider the overall mounting depth of the controller with pitot, static, and electrical connections and allow clearance where necessary, especially surrounding the moving yoke assembly.
 - 2.2. Ensure that mounting location does not require autopilot servo lines to run near com antenna coax.
 - 2.3. Ensure that there is sufficient space near the autopilot controller to install the Vizion Limitations Placard (Trutrak P/N 8300-092)
3. Open required inspection panels and access panels for harness routing.
 - 3.1. Remove the right and left panel overlays and the left instrument panel.
 - 3.2. Remove interior trim from covering the right forward door pillar to expose the areas shown in figures 4-1 and 4-2.



Figure 4-1

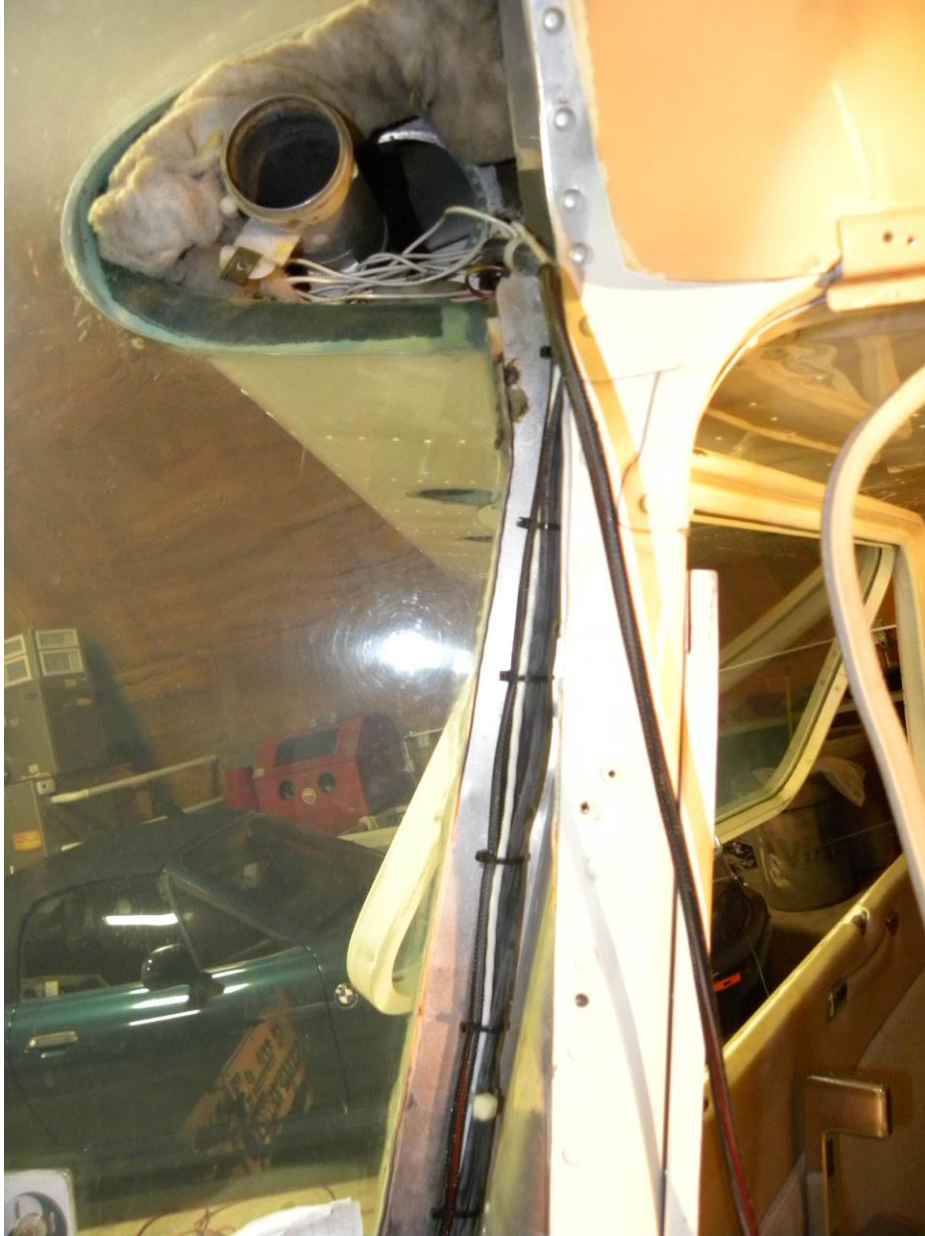

Figure 4-2

4. Continue with opening of access panels
 - 4.1. Open inspection covers as shown in figure 4-3.



Figure 4-3

5. Begin routing wiring harness.
 - 5.1. Route the pitch (short) and roll (long) servo harnesses down the left side of the center stack as shown in figures 4-4 and 4-5. The blue line in Figure 4-4 shows the main autopilot bundle. The red line in figure 4-5 shows the roll servo harness and the green line shows the pitch servo harness.



Figure 4-4

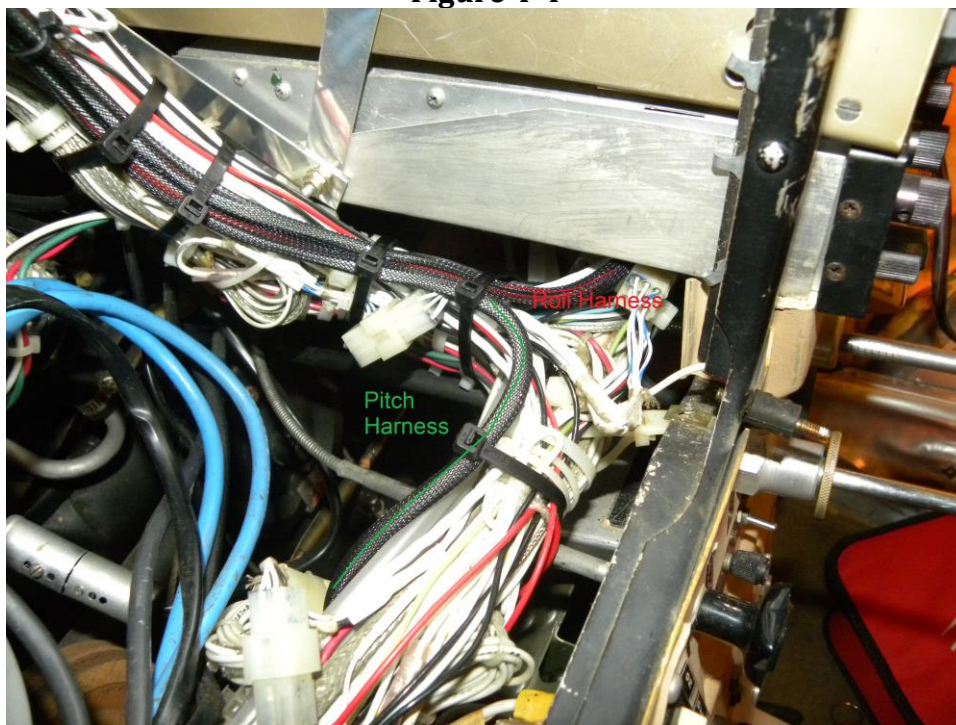

Figure 4-5

6. Continue routing wiring harness. The green line in Figure 4-6 shows the path the harness should take.
 - 6.1. Continue running the pitch servo wiring harness down the front left side of the center console to the pitch servo located under the panel as shown in figure 4-6.



Figure 4-6

7. Terminate the pitch servo wiring harness per the Vizion wiring diagram in the Vizion PMA Installation Guide (TruTrak Doc. 166) using **OPTION A**.

8. Begin routing roll servo harness as shown in Figure 4-7. The red line shows the approximate path the harness should take.
 - 8.1. Route the roll servo wiring harness under the avionics stack and over the right yoke to the right side of the panel.
 - 8.2. Secure the harness to the existing wiring bundle using cable ties.

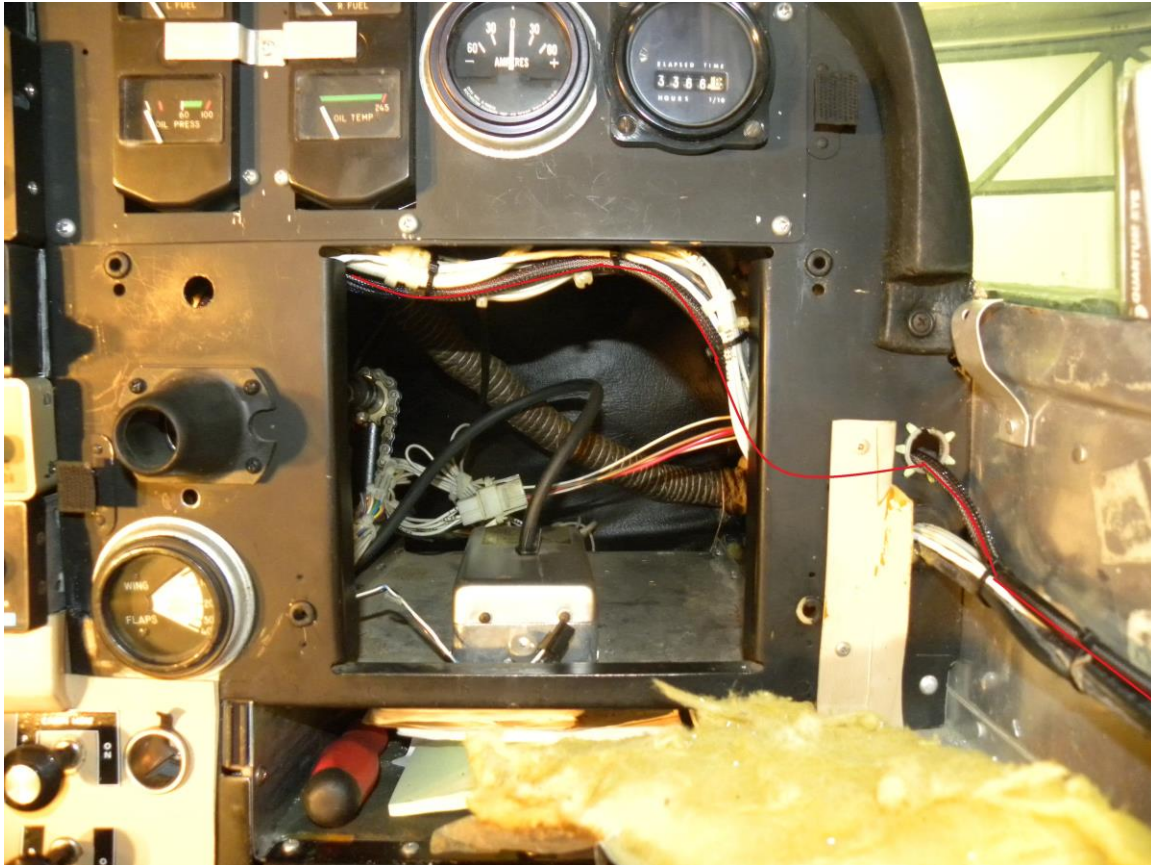

Figure 4-7

10. Continue roll servo harness routing. The red line in Figures 4-8, 4-9, and 4-10 shows the path the harness should take.

10.1. Follow the existing wiring harness up the right front door post and through the grommets into the first inspection panel in the leading edge of the wing.



Figure 4-8



Figure 4-9



Figure 4-10

12. Continue roll harness routing in right wing.

- 12.1. Continue following the existing wiring harness through the grommets in the leading edge ribs past the second inspection hole. The red line in Figure 4-11 shows the pathway the harness should take.

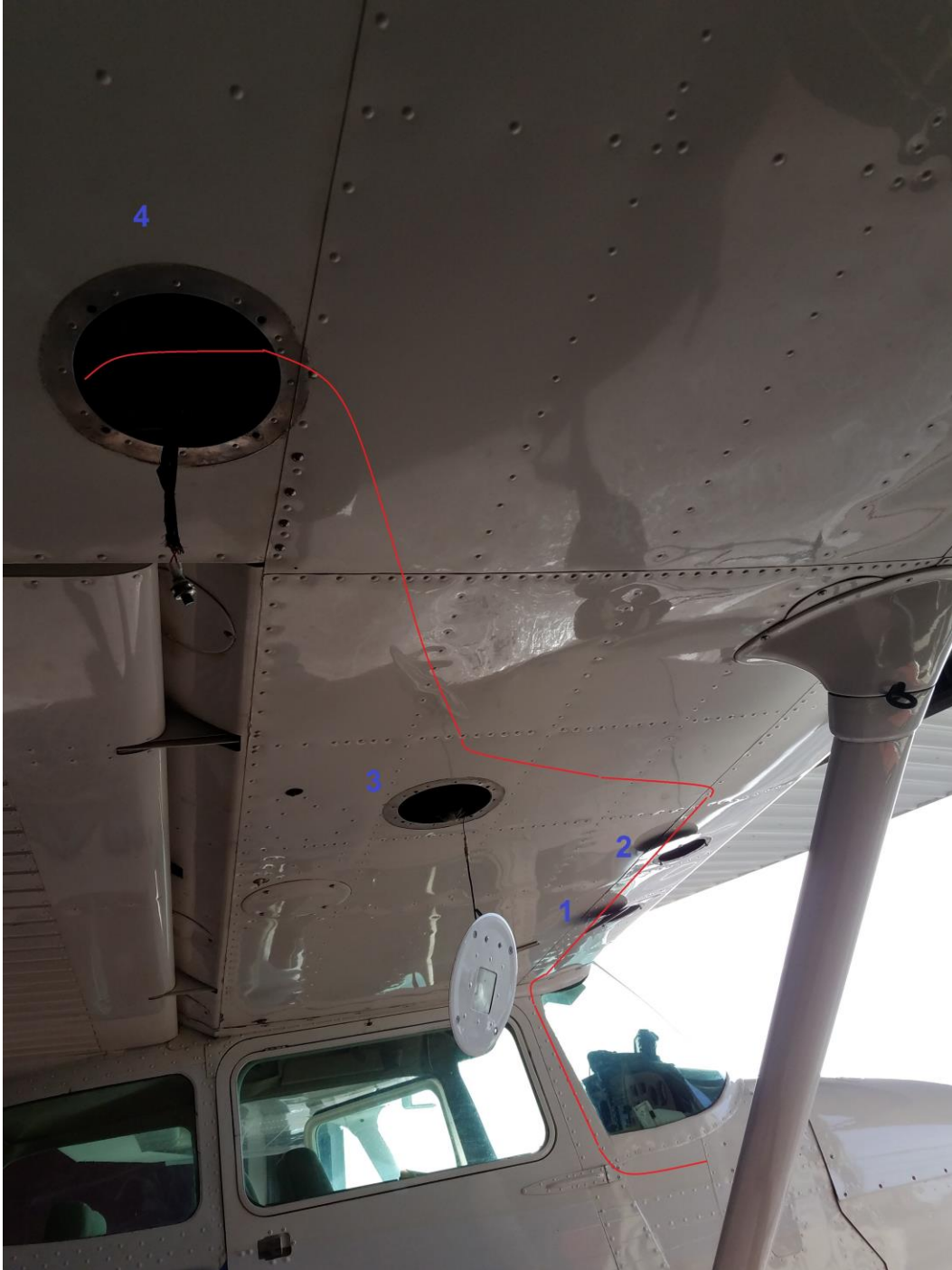

Figure 4-11

13. Install grommet edging on the lightning hole outboard of inspection hole 3 as shown in figure 4-12.



Figure 4-12

15. Continue installation of grommet edging.

- 15.1. Install grommet edging on the outer lightening hole forward of inspection hole 4 as shown in figure 4-13. The wiring harness must run through this lightening hole to prevent interference with servo and control cable movement.



Figure 4-13

16. Terminate the roll servo wiring harness per the Vizion wiring diagram in the Vizion PMA Installation Guide (TruTrak Doc. 166).
17. Reinstall cover plates on inspection holes 1, 2, and 3. Leave cover plate 4 open until the roll servo installation is complete.
18. Select appropriate mounting locations for the AP Master, AP Circuit Breaker, Emergency Level and control wheel steering switches. Connect these items per the Vizion wiring diagram in the Vizion PMA Installation Guide (TruTrak Doc. 166).
19. **All items in step 18 are required to be installed. The AP Master Switch, AP Circuit Breaker, and Control Wheel Steering switches must be labeled. The Control Wheel Steering Switch must be red.**

20. Connect GPS inputs per the Vizion wiring diagram in Vizion PMA Installation Guide (TruTrak Doc. 166)
21. Reinstall interior trim.
- 22. Conduct pitot / static check of aircraft system before opening any pitot/ static connections!**
23. Mount autopilot controller in panel using 4 6-32 X 3/8" screws. Connect wiring harness and connect pitot and static per Vizion PMA Installation Guide (TruTrak Doc. 166).
24. Install Vizion Limitations Placard (TruTrak P/N 8300-092) near the Vizion autopilot. A sample panel with potential placard location is shown below:

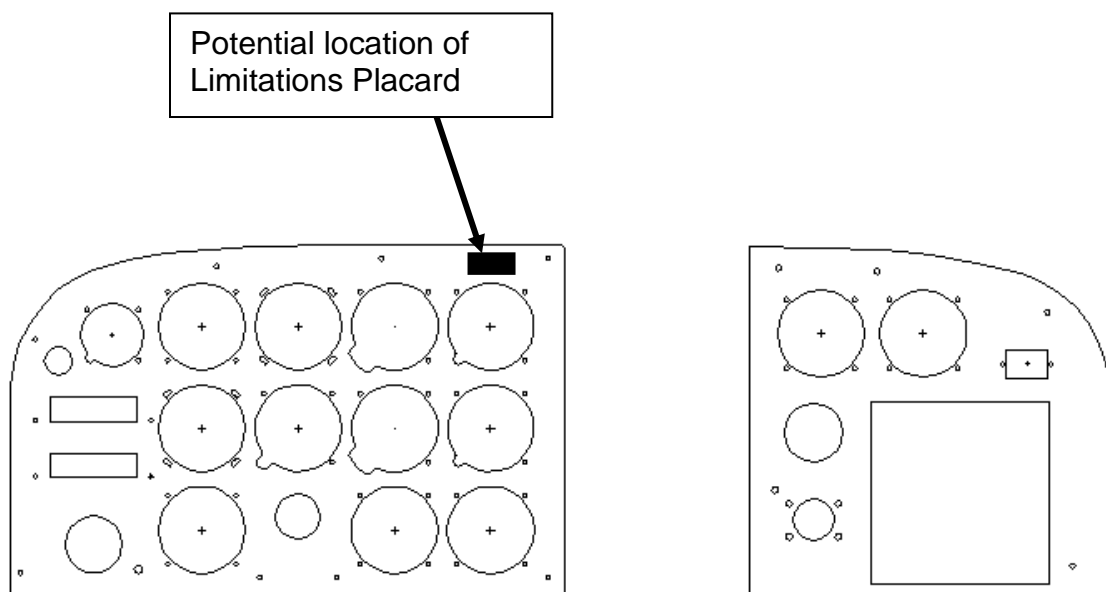

25. Reinstall the instrument panel and panel overlays.
26. If not already installed, install pitch and roll servos.
27. Reconnect battery.
28. Once autopilot settings are confirmed, perform autopilot system test per the Vizion PMA Installation Guide (TruTrak Doc. 166).

4.3.Cessna 172 F – S Vizion Wiring Harness IPC

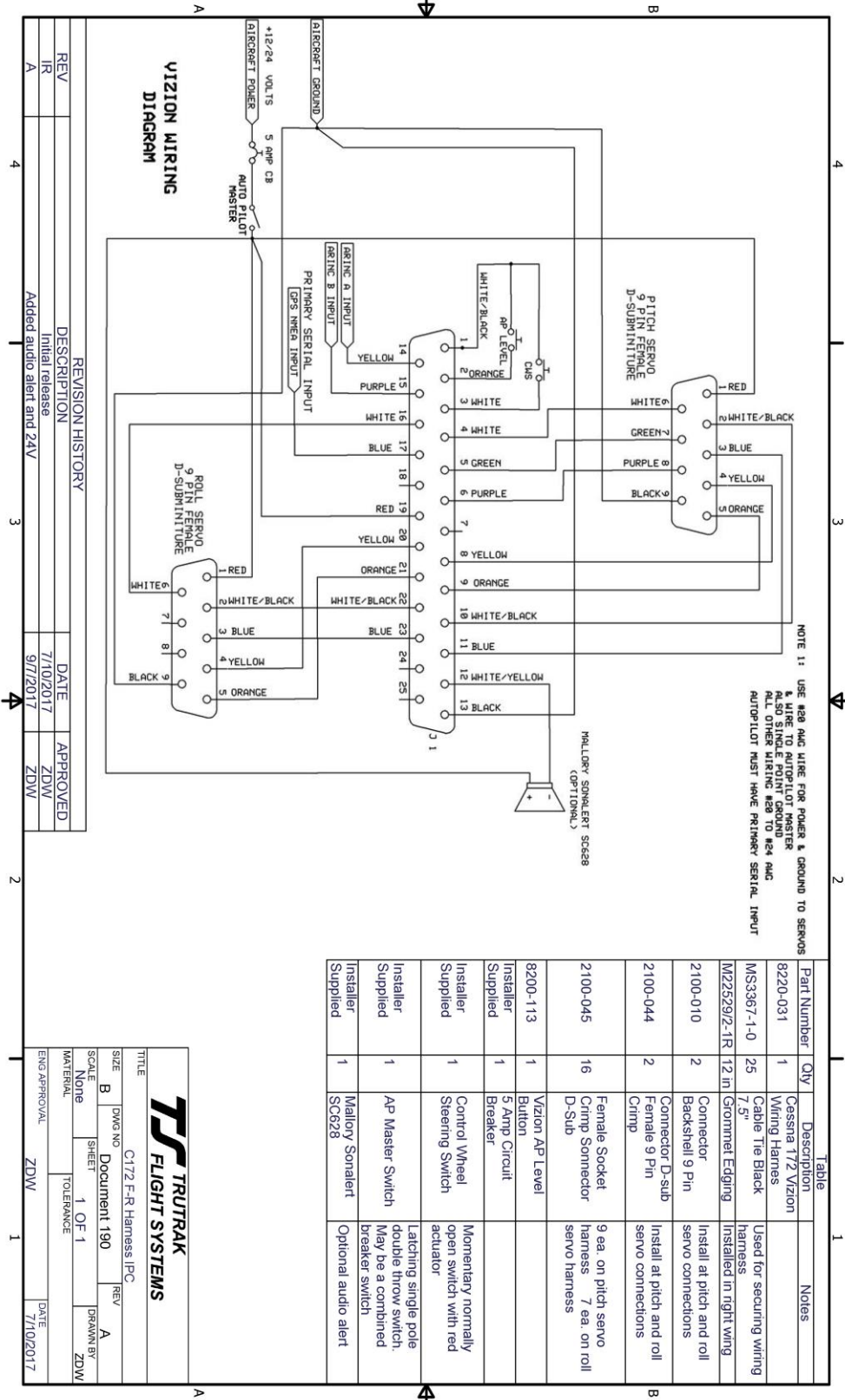

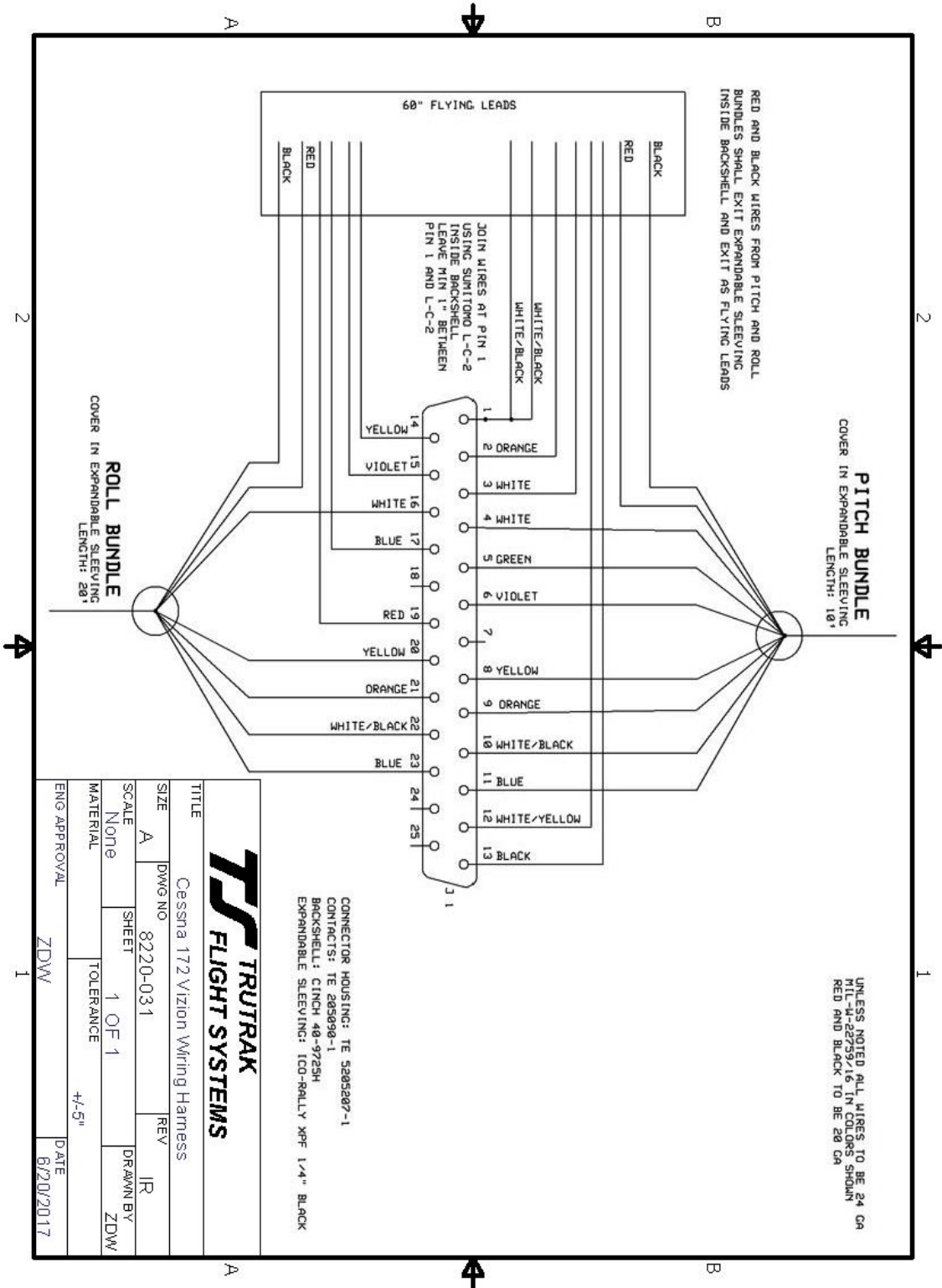

5. Cessna 172 F – 172 R Autopilot Settings

Once all wiring is complete, verified, and the GPS setup has been completed (Vizion PMA Installation Guide (TruTrak Doc. 166)), follow the steps below to verify proper autopilot settings.

THIS STEP MUST BE COMPLETED PRIOR TO GROUND CHECK AND FLIGHT CHECK!!!

5.1. Lateral Autopilot Settings

- 1) PRESS and HOLD KNOB
- 2) Apply power to autopilot and GPS
- 3) Release KNOB.
- 4) PRESS KNOB to advance to min backlight
- 5) PRESS KNOB to advance to SETUP ENABLE.
- 6) ROTATE KNOB to select a value of **10**.
- 7) PRESS KNOB to exit.
- 8) PRESS and HOLD MODE button until LAT ACTIVITY is shown.
- 9) ROTATE KNOB to select a LAT ACTIVITY of **17**
- 10)PRESS ALT button to advance to next setup screen.
- 11)ROTATE KNOB to select a BAUD that matches the baud rate of the GPS (this will be either **4800** or **9600**).
- 12)PRESS ALT button to advance to next setup screen.
- 13)ROTATE KNOB to select a BANK ANGLE of **MED**.
- 14)PRESS ALT button to advance to next setup screen.
- 15)ROTATE KNOB to select a MICROACTIVITY of **10**.
- 16)PRESS ALT button to advance to next setup screen.
- 17)ROTATE KNOB to select a GPSS GAIN of **16**.
- 18)PRESS ALT button to advance to next setup screen.
- 19)ROTATE KNOB to set ROLL REV to **Y**.
- 20)PRESS KNOB exit lateral setup and return to the home screen.
- 21)PRESS ALT AND HOLD alt button until VRT AVTIVITY is shown.
- 22)WHILE CONTINUING TO HOLD ALT, PRESS MODE.
- 23)RELEASE MODE AND ALT.
- 24)PRESS MODE until MAC is displayed.
- 25)ROTATE KNOB to set MAC to **2**.
- 26)PRESS KNOB to exit menu and return to home screen.
- 27)Do not remove power from autopilot.

5.2. Vertical Autopilot Settings

- 1) PRESS and HOLD ALT button until VRT ACTIVITY is shown.
- 2) ROTATE KNOB to select a VRT ACTIVITY of **16**.
- 3) PRESS ALT button to advance to next setup screen.
- 4) ROTATE KNOB to select a MIN AIRSPD of (Refer to aircraft POH and set a value equal to 1.3 V_s in knots).
- 5) PRESS ALT button to advance to next setup screen.
- 6) ROTATE KNOB to select a MAX AIRSPD of (Refer to aircraft POH and set a value equal to 0.9 V_{NE} in knots).
- 7) PRESS ALT button to advance to next setup screen.
- 8) ROTATE KNOB to select a PITCH REV of **N**.
- 9) PRESS ALT button to advance to next setup screen.
- 10) ROTATE KNOB to select a STATIC LAG of **0**.
- 11) PRESS ALT button to advance to next setup screen.
- 12) ROTATE KNOB to select a MICROACTIVITY of **6**.
- 13) PRESS ALT button to advance to next setup screen.
- 14) ROTATE KNOB to select a HALF STEP of **N**.
- 15) PRESS KNOB exit vertical setup and return to the home screen.
- 16) Cycle power on the autopilot.



TruTrak Flight Systems, Inc.