



Appendix C

Vizion PMA Autopilot 175 and 172 All Models Installation

**RESTRICTION ON USE, DUPLICATION, OR DISCLOSURE OF
PROPRIETARY INFORMATION**

THIS DOCUMENT CONTAINS PROPRIETARY INFORMATION OF TRUTRAK FLIGHT SYSTEMS, INC. AND MAY NOT BE REPRODUCED, COPIED, DISCLOSED OR UTILIZED IN ANY WAY, IN WHOLE OR IN PART, WITHOUT THE PRIOR WRITTEN CONSENT OF TRUTRAK FLIGHT SYSTEMS, INC.

Prepared by

TruTrak Flight Systems, Inc.

	Function/Title	Name
Prepared by	Engineering	Moss Foster
Prepared by	President	Andrew Barker
Checked by	GM	Moss Foster
Approved by	President	Andrew Barker



Table of Contents

1. Document Revision History	3
2. Cessna 175/172 All Models Roll Servo Installation	4
2.1. Materials List	4
2.2. Roll Servo Mounting Instructions	5
2.3. Cessna 175/172 All Models Vizion Roll IPC	17
3. Cessna 175/172 All Models Pitch Servo Installation	18
3.1. Pitch Servo Mounting Materials List	18
3.2. Pitch Servo Mounting Instructions	19
3.3. Cessna 175/172 All Models Vizion Pitch IPC	29
4. Cessna 175/172 All Models Wiring Harness Installation	30
4.1. Wiring Harness Materials List	30
4.2. Wiring Harness / Controller Mounting Instructions	31
5. Cessna 175/172 All Models Autopilot Settings	49
5.1. Lateral Autopilot Settings	49
5.2. Vertical Autopilot Settings	50



1. Document Revision History

Rev	Description	Pages	Date
IR	Preliminary manual created	51	1-8-18
A	Corrected part number references for 7100-099, 7100-100, and 7100-101	18-28	3-22-19



2. Cessna 175/172 All Models Roll Servo Installation

2.1. Materials List

- 1 ea. 60 inch/lb PMA servo, TruTrak P/N 8100-064
- OR
- 1ea. 60 inch/lb 24 Volt PMA servo, TruTrak P/N 8100-065

- 1 ea. Cessna 172 Upper Roll Bracket, Trutrak P/N 1450-107
- 1 ea. Cessna 172 Lower Roll Bracket, Trutrak P/N 1450-108
- 1 ea. Cessna 172 Roll Inboard Pushrod, Trutrak P/N 7200-088
- 1 ea. Cessna 172 Roll Outboard Pushrod, Trutrak P/N 7200-090
- 1 ea. Cessna 172 Roll Servo Arm, Trutrak P/N 7200-091
- 1 ea. Servo Bolt Pattern Plate, TruTrak P/N 1420-216
- 3 ea. 8-32 x 3/8 Flat Head Socket Cap Screw SS, Trutrak P/N 2500-216
- 2 ea. MM-3-300 Rod End Bearing, Trutrak P/N 2510-051
- 2 ea. AN345-10 nut
- 7 ea. AN526C-832R8 Screw
- 7 ea. MS21051-08 Anchor Nut
- 14 ea. MS20426AD3-4 Rivet
- 4 ea. AN3-3A Bolt
- 1 ea. AN3-14A Bolt
- 3 ea. AN3-7A Bolt
- 4 ea. MS35333-39 Internal Lock Washer
- 4 ea. AN960-10 Washer
- 2 ea. AN970-3 Washer
- 2 ea. MS20364-1032 Nut

2.2. Roll Servo Mounting Instructions

1. The roll servo will be mounted in the right wing just forward of the inboard end of the aileron.
 - 1.1. Begin by removing the inspection cover on the lower wing skin located forward of the inboard end of the aileron.
 - 1.2. Figure 2-1 shows the roll servo mounting location from above the right wing and figure 2-2 shows the mounted servo in the wing.
 - 1.3. **NOTE: Apply torque seal to all bolts after final torqueing is achieved.**



Figure 2-1

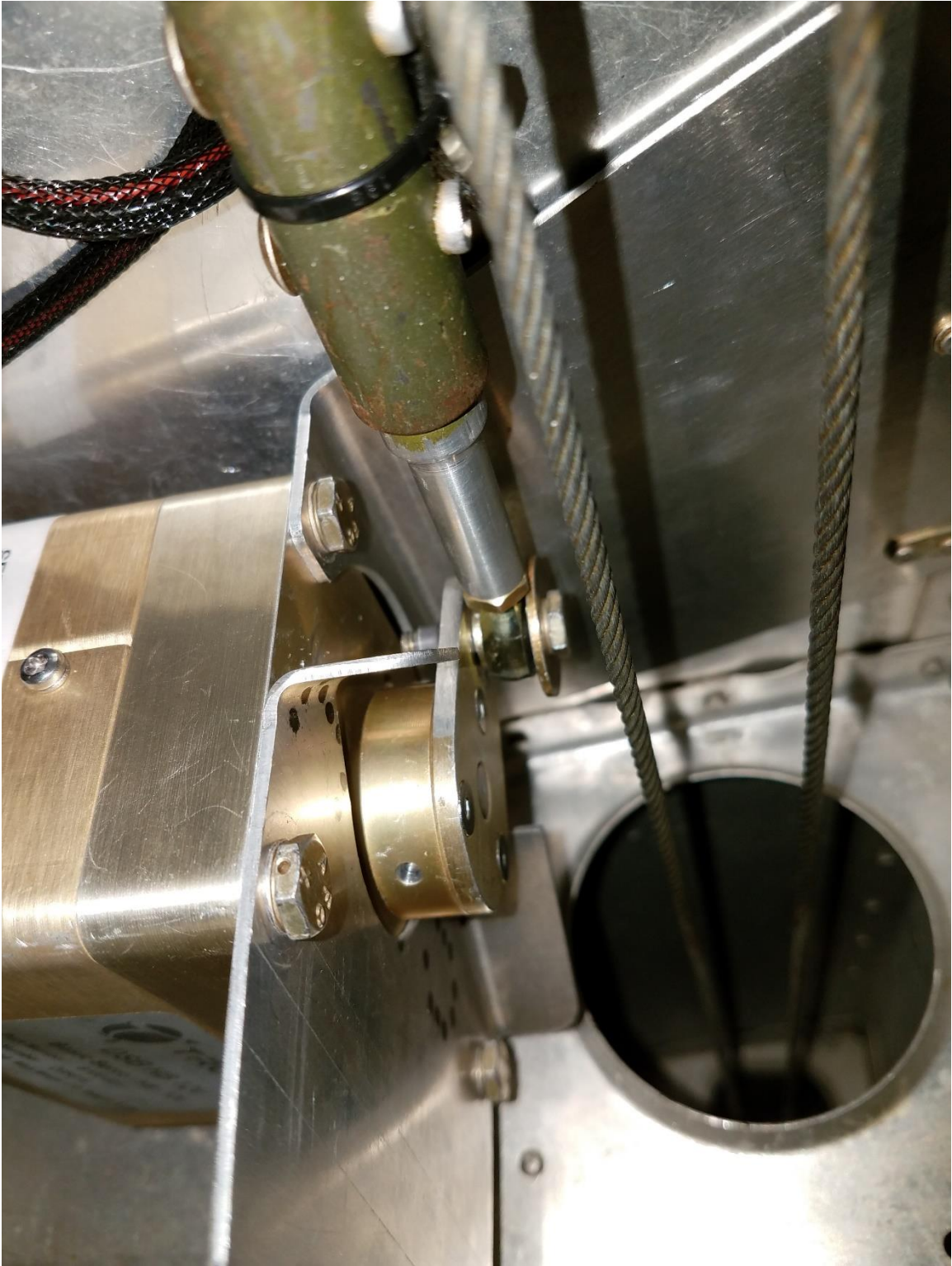

Figure 2-2

2. The Cessna 172 Upper Roll Bracket (P/N 1450-107) will be mounted to the flange of the rear wing spar using 3 ea. AN526C-832R8 screws.
 - 2.1. Locate the inboard screw hole as shown in figure 2-3 on the upper wing skin.
 - 2.2. Drill the inboard hole only at this time with a #19 drill.

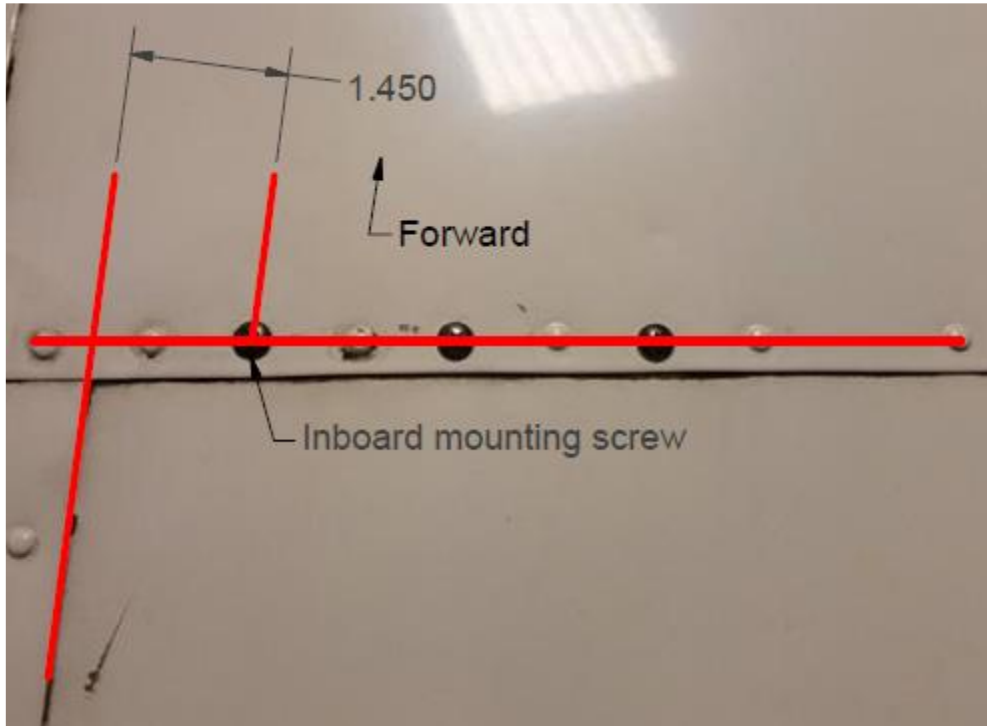

Figure 2-3

3. Drill Cessna 172 Upper Roll Bracket (P/N 1450-107) mounting holes.
 - 3.1. Place the upper roll servo bracket in the wing and temporarily attach the bracket using a cleco in the previously drilled hole.
 - 3.2. Rotate the bracket so that the outboard hole is aligned with the row of rivets in the spar flange.
 - 3.3. Use a right angle drill to match drill the outer screw hole from inside the wing.
 - 3.4. Use a cleco to temporarily attach the outer screw hole and then match drill the center screw hole on the top bracket to the spar flange.

4. Install anchor nuts in Cessna 172 Upper Roll Bracket (P/N 1450-107)
 - 4.1. Remove the bracket from the aircraft.
 - 4.2. Rivet 3 ea. MS21051-08 anchor nuts in place using 6 ea. MS20426AD3-4 rivets as shown in figure 2-4.

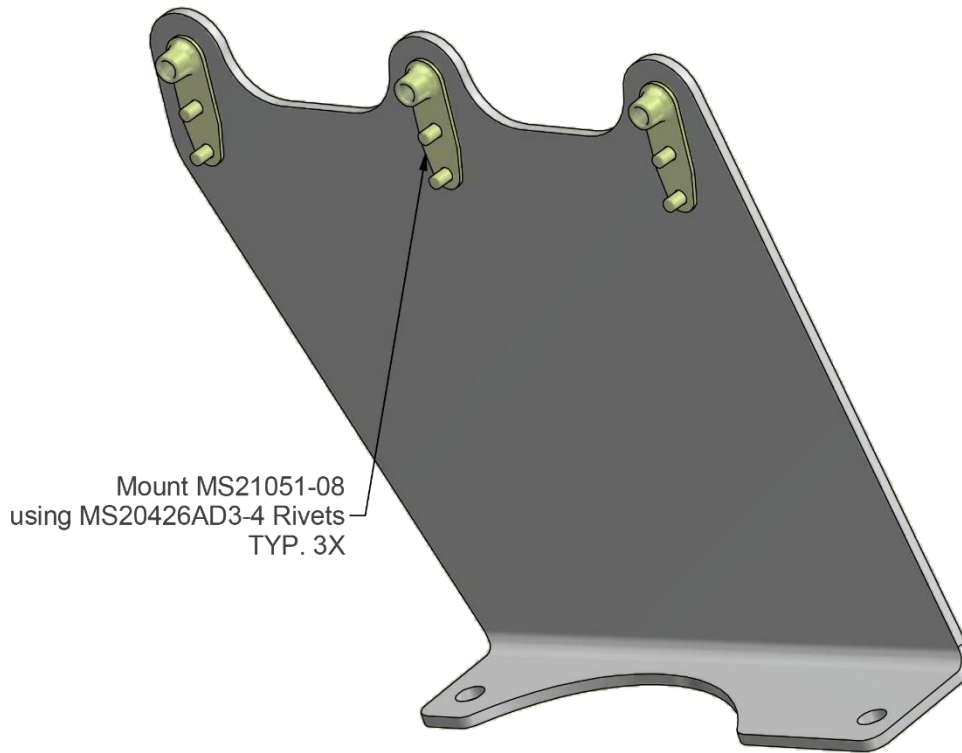

Figure 2-4

5. Install and temporarily assemble Cessna 172 Upper Roll Bracket (P/N 1450-107), Servo Bolt Pattern Plate (P/N 1420-216), and Cessna 172 Lower Roll Bracket, (P/N 1450-108)
 - 5.1. Attach the Cessna 172 Upper Roll Bracket (P/N 1450-107) to the upper spar flange using 3 ea. AN526C-832R8 screws.
 - 5.1.1. Ensure that screws are tight, as this part will not be removed after this step!**
 - 5.2. Temporarily attach the Servo Bolt Pattern Plate (P/N 1420-216) to the upper bracket using 2 ea. AN3-3A as shown in figure 2-5.
 - 5.3. Temporarily attach the Cessna 172 Lower Roll Bracket, (P/N 1450-108) to the Servo Bolt Pattern Plate (P/N 1420-216) using 2 ea. AN3-3A as shown in figure 2-5.

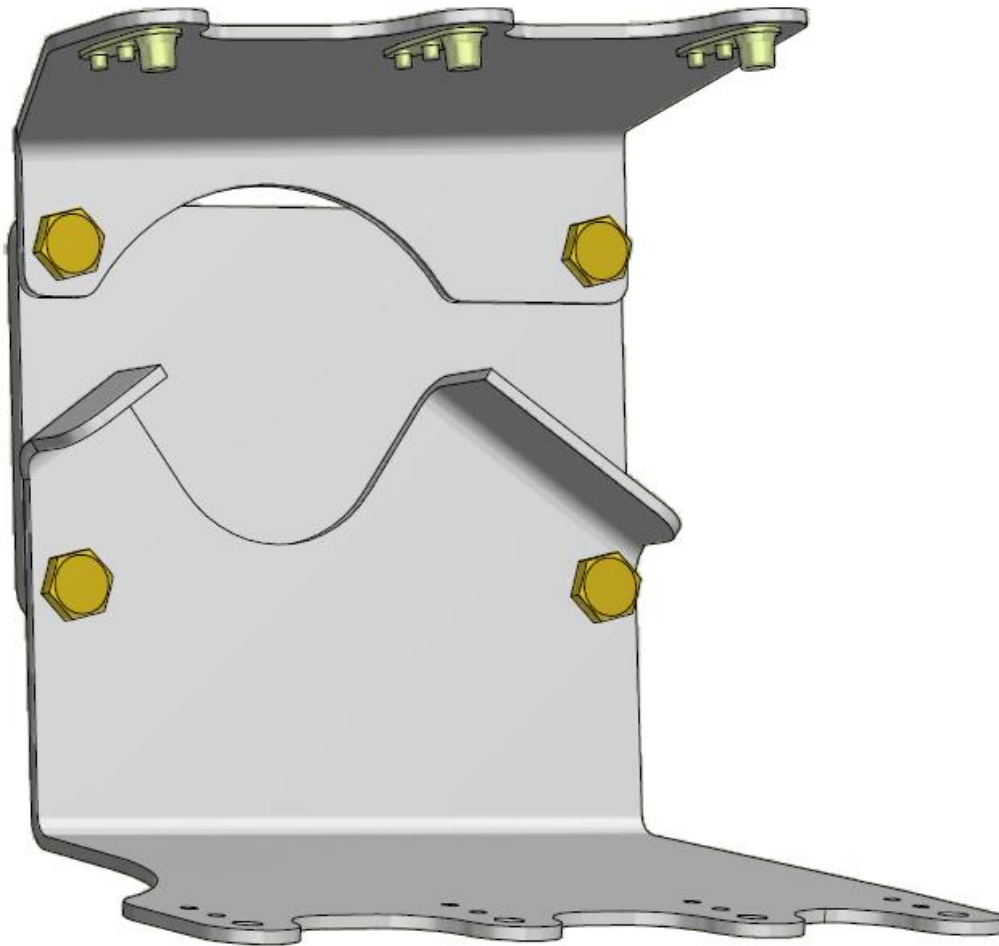

Figure 2-5

6. Drill Cessna 172 Lower Roll Bracket, (P/N 1450-108) mounting holes.
 - 6.1. Align the lower bracket mounting holes with row of rivets on the lower spar flange.
 - 6.2. Match drill the outboard mounting hole using a #19 bit.
 - 6.3. Secure the outboard hole with a cleco.
 - 6.4. Match drill the remaining 3 holes on Cessna 172 Lower Roll Bracket, (P/N 1450-108), installing a cleco after each hole is drilled.

NOTE: Do not install the bracket until step 13.

7. Install anchor nuts in Cessna 172 Lower Roll Bracket (P/N 1450-108)
 - 7.1. Remove Servo Bolt Pattern Plate (P/N 1420-216), and Cessna 172 Lower Roll Bracket, (P/N 1450-108))
 - 7.2. Rivet 4 ea. MS21051-08 anchor nuts in place using 8 ea. MS20426AD3-4 rivets as shown in figure 2-6.

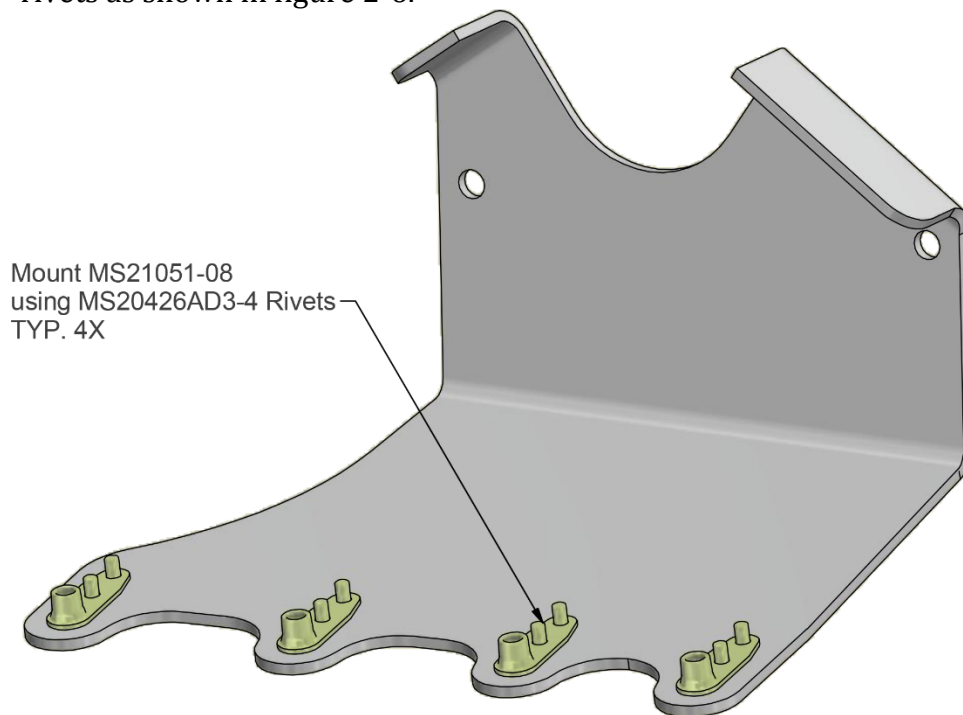

Figure 2-6

8. Install and assemble the Cessna 172 Roll Inboard Pushrod (P/N 7200-088) and Cessna 172 Outboard Pushrod (P/N 7200-090). Figure 2-7 shows the assembled joint of these two parts.
 - 8.1. Verify that Cessna 172 Roll Inboard Pushrod, Cessna 172 Outboard Pushrod, and AN3-7A bolts all mate properly prior to inserting parts through inspection hole.
 - 8.2. Ensure that both threaded inserts are free of burs and rod end bearings can be properly inserted.
 - 8.3. Slide the Cessna 172 Roll Inboard Pushrod (P/N 7200-088) through the inspection hole toward the cabin until the pushrod is entirely in the wing.
 - 8.4. Make sure that the 10-32 threaded insert is toward the cabin and the cross drilled insert is outboard.
 - 8.5. Place the Cessna 172 Outboard Pushrod (P/N 7200-090) through the inspection hole with the 10-32 threaded insert outboard.
 - 8.6. Align the cross bolt holes and slide the inner and outer pushrods together.
 - 8.7. Bolt the sections together using 2 AN3-7A bolts and MS20364-1032 nuts torqued to 20-25 in-lb.
 - 8.8. Apply torque seal to this assembly at this point, as it is difficult to reach once attached to servo and bellcrank.
 - 8.9. Remove the aileron bellcrank inspection panel and slide the assembled pushrod outward until it reaches the aileron bellcrank.

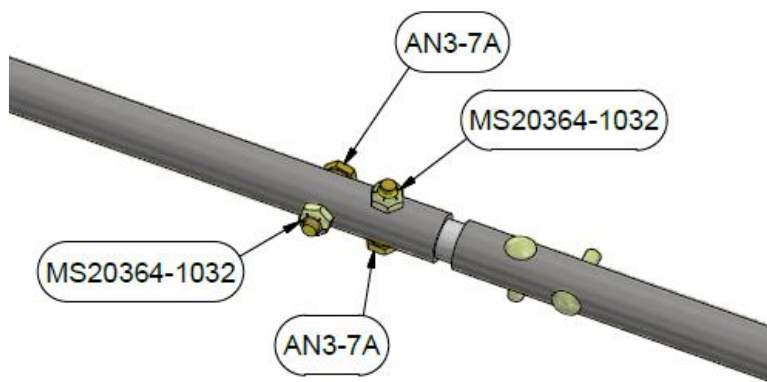

Figure 2-7

9. Attach rod end bearing to bellcrank.
 - 9.1. Remove the rear aileron bellcrank cable attachment bolt and replace with an AN3-14A, MM-3-300, 2 ea. AN960-10, and AN970-3 washer as shown in figure 2-8.
 - 9.2. Torque bolt to 20-25 in-lb.
 - 9.3. Verify that the feel of the controls in roll have not changed as this could indicate that a control cable has come off of the pulley. This bolt replacement should be able to be accomplished without re-tensioning the aileron control cables.

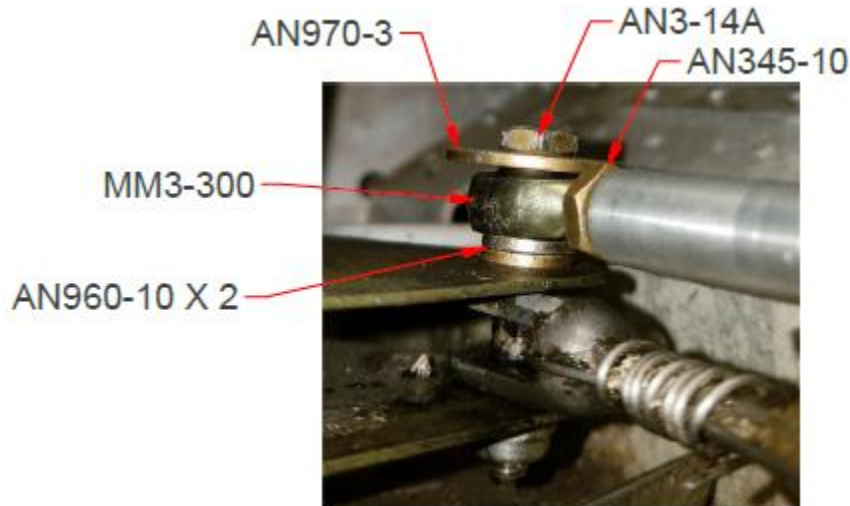

Figure 2-8

10. Attach assembled pushrod to bellcrank rod end bearing.
 - 10.1. Fully thread an AN345-10 nut on both MM-3-300 rod end bearings and start threading the pushrod assembly to the outer rod end bearing.
11. Assemble Cessna 172 Roll Servo Arm (P/N 7200-091) and 60 inch/lb PMA servo (P/N 8100-064).
 - 11.1. Attach the Cessna 172 Roll Servo Arm (P/N 7200-091) to the 60 inch/lb PMA servo (P/N 8100-064 for 12 volt or P/N 8100-065 for 24 volt) using the provided 8-32 x 3/8" flat head screws.
 - 11.2. Use blue threadlocker (Loctite 242 or equivalent) and torque the screws to 18-20 in-lb.

12. Roll servo installation should be paused at this step, and continued once the wiring is installed per section 4.
13. Install Cessna 172 Lower Roll Bracket, (P/N 1450-108) and 60 inch/lb PMA servo (P/N 8100-064 for 12 volt or P/N 8100-065 for 24 volt).
 - 13.1. Place the lower roll servo bracket in the wing and start 4 AN526C-832R8 screws but leave the screws loose so that the lower bracket can still move.
 - 13.2. Attach the electrical connector to the roll servo and secure it in place with the mounting screws.
 - 13.3. Place the servo behind the mounting bracket with the arm oriented between the servo stops as shown in figure 2-9.
 - 13.4. Start the 2 AN3-3A bolts with MS35333-39 lock washers and blue threadlocker (Loctite242 or equivalent) in the upper servo mounting holes then start the lower mounting bolts in the same manner.
 - 13.5. Finally torque the 4 servo mounting bolts to 20-25 in-lb and tighten the lower bracket mounting screws to the spar flange. Figure 2-10 shows the 4 screws in the lower spar flange.

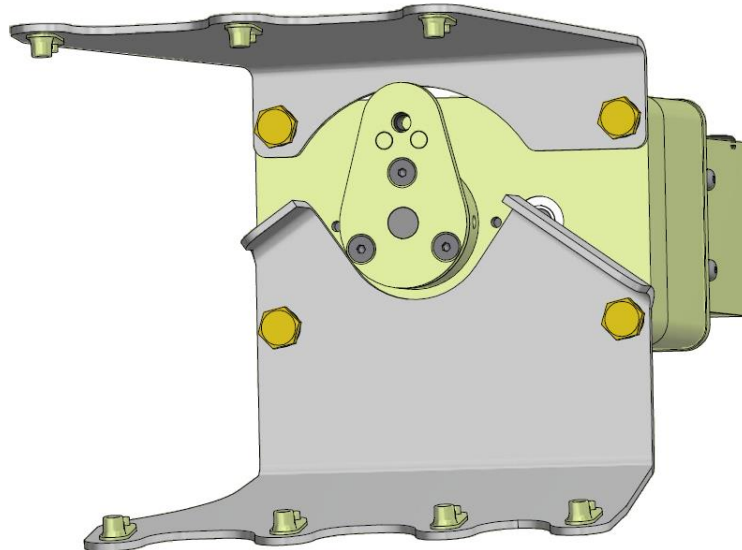

Figure 2-9



Figure 2-10

14. Install servo side rod end bearing in push rod assembly.
 - 14.1. Have an assistant hold the yoke in the full left position and rotate the servo arm against the outboard stop as shown in figure 2-11.
 - 14.2. Thread the MM-3-300 rod end bearing into the servo end of the pushrod until the pushrod is the correct length to align with the drive point on the servo arm. The pushrod must be positioned aft of the rear aileron control cable at the servo and above the control cable at the aileron bellcrank.
 - 14.3. Verify that the control cable is not twisted around the pushrod.

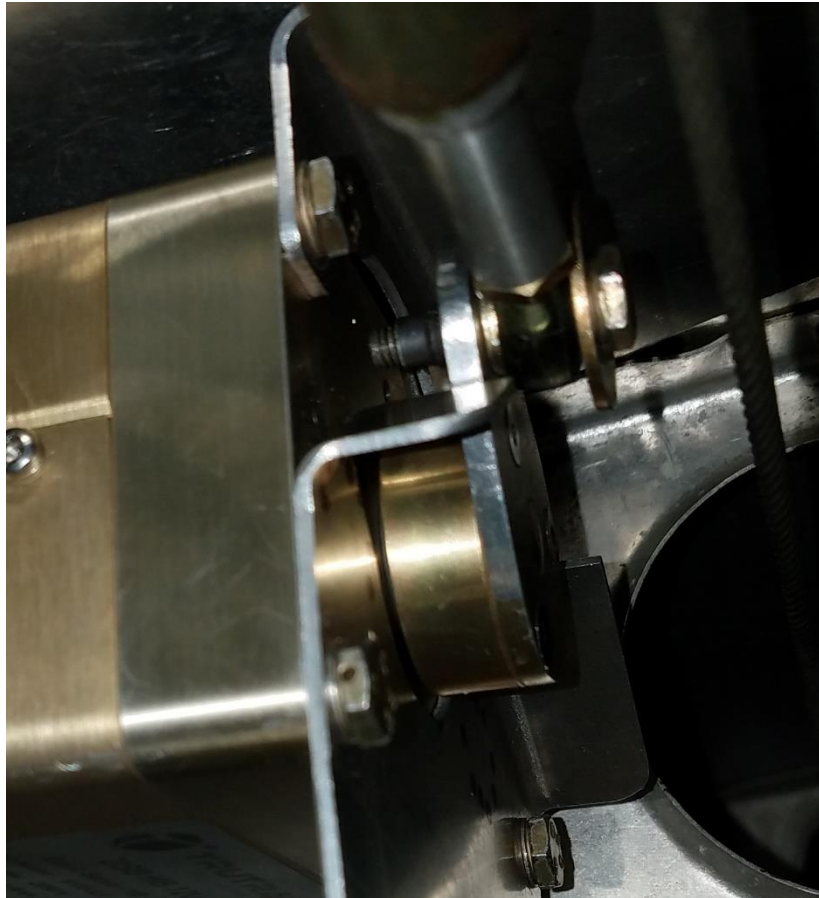

Figure 2-11

15. Attach the pushrod assembly to the Cessna 172 Roll Servo Arm (P/N 7200-091).
 - 15.1. Attach the pushrod with hardware as shown in figure 2-12 and torque to 20-25 in-lb.
 - 15.2. Rotate the pushrod until the rod end bearings on each end are threaded in equally then tighten the jam nuts to 20-25 in-lb.
 - 15.3. Move the yoke throughout the full range of travel and check for binding in the rod end bearings. If binding exists adjust the rod end bearings and jam nuts to eliminate it.
 - 15.4. **Ensure that aircraft stops are contacted prior to servo stops. Adjust length of pushrod as needed until servo stops are not contacted when controls are moved to both ends of travel.**

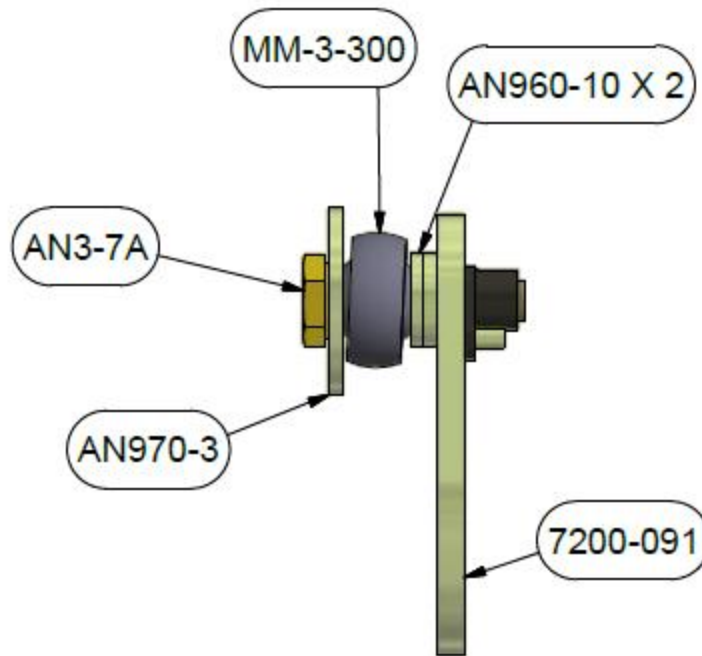
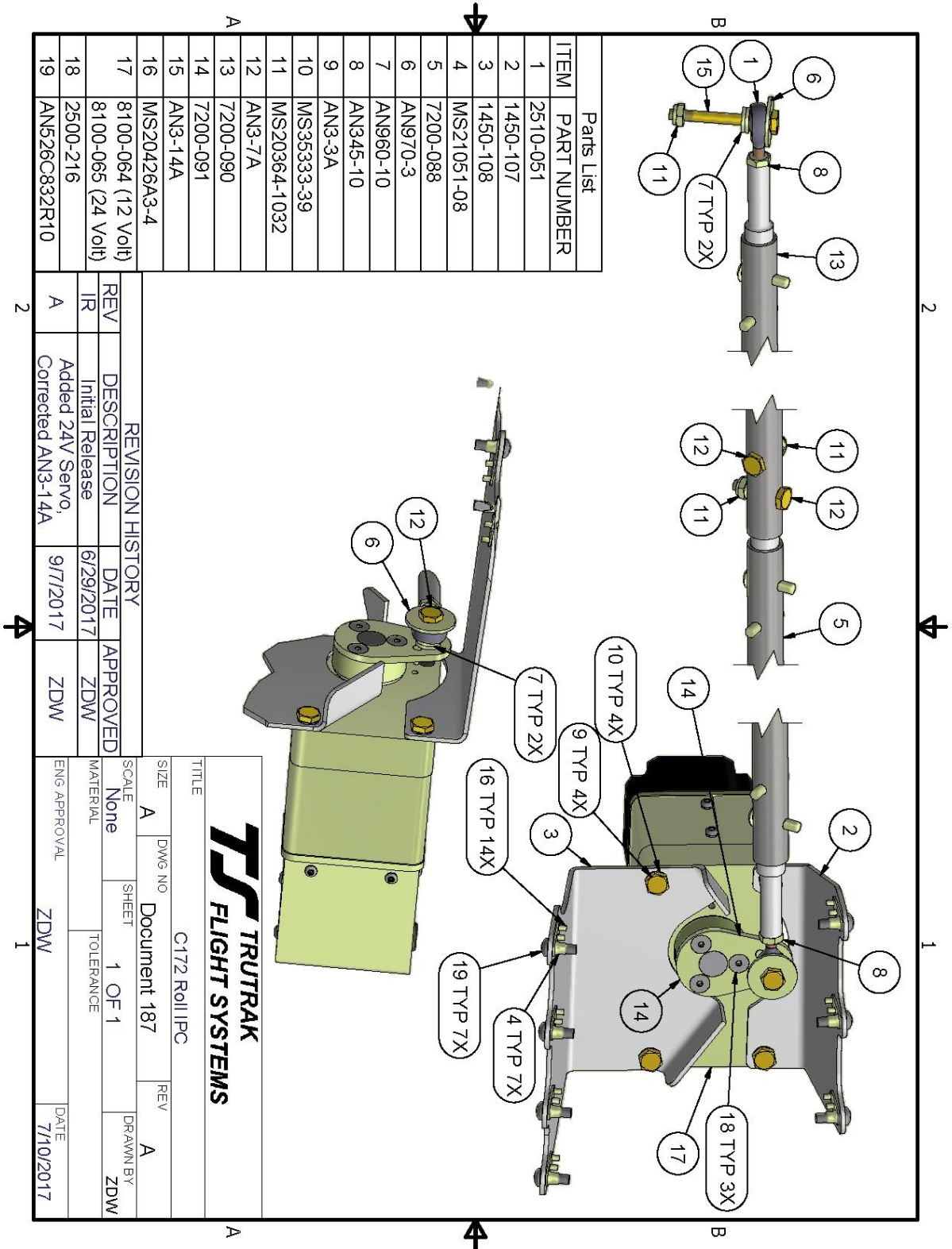

Figure 2-12

16. Verify that the servo and pushrod motion are unobstructed throughout the full control travel. Once wiring harness is installed, ensure that the wiring harness is properly secured to prevent interference.
17. **Apply torque seal to all bolts after final torquing is achieved.**

2.3. Cessna 175/172 All Models Vizion Roll IPC



ITEM	PART NUMBER
1	2510-051
2	1450-107
3	1450-108
4	MS21051-08
5	7200-088
6	AN970-3
7	AN960-10
8	AN345-10
9	AN3-3A
10	MS35333-39
11	MS20364-1032
12	AN3-7A
13	7200-090
14	7200-091
15	AN3-14A
16	MS20426A3-4
17	8100-064 (12 Volt)
18	8100-065 (24 Volt)
19	AN526C832R10

REVISION HISTORY			
REV	DESCRIPTION	DATE	APPROVED
IR	Initial Release	6/29/2017	ZDW
A	Added 24V Servo, Corrected AN3-14A	9/7/2017	ZDW

TITLE		C172 Roll IPC	
SIZE	DWG NO	REV	
A	Document 187	A	
SCALE	SHEET	DRAWN BY	
None	1 OF 1	ZDW	
MATERIAL	TOLERANCE	DATE	
		7/10/2017	
ENG APPROVAL		DATE	
ZDW		7/10/2017	

3. Cessna 175/172 All Models Pitch Servo Installation

3.1. Pitch Servo Mounting Materials List

Qty	Description	Part Number
1	60 inch/lb 12 Volt PMA Servo OR 60 inch/lb 24 Volt PMA Servo	8100-064 OR 8100-065
1	1.5" PMA Servo Arm	1420-209
1	C172 Early Pitch Clamp Link Sensor Half	1420-227
1	C172 Early Pitch Clamp Half	1420-228
1	Cessna 172 Early Aft Pitch Bracket	1450-121
9	MS20364-1032	
1	AN970-3	
1	AN345-10	
8	AN3-5A	
2	AN3-6A	
1	AN3-10A	
10	AN3-3A	
3	AN960-10	
4	MS35333-39	
3	8-32 x 3/8 Flat Head Socket Cap Screw SS	2500-216
1	AN4H-3A	
1	MM-3-300 Rod End Bearing	2510-051
16	Cherry BSPQ-42 Rivet	
1	Sheathed Microfit Cable Assembly 1M	6000-064
1	C172 Early Pitch Pushrod Assembly	7100-099
1	C172 Early Fore Pitch Bracket Assembly	7100-100
1	C172 Early Pitch Servo Bracket Assembly	7100-101

3.2. Pitch Servo Mounting Instructions

1. **Before beginning installation ensure elevator cable tension is within factory specification.**
2. The pitch servo will be mounted in the empennage below the vertical stabilizer as shown in figure 3-1.



Figure 3-1

3. Assemble the PMA Servo Bracket Assembly.
 - 3.1. Assemble PMA Servo (P/N 8100-064 OR 8100-065) and 1.5" PMA Servo Arm (P/N 1420-209) using 3 8-32 x 3/8 Flat Head Socket Cap Screws (P/N 2500-216) with blue threadlocker (Loctite 242 or equivalent) and torque the screws to 18-20 in-lb.
 - 3.2. Assemble PMA Servo (P/N 8100-064 OR 8100-065) and C172 Early Pitch Servo Bracket Assembly (P/N 7100-101) using 4 AN3-3A bolts and 4 MS35333-39 lock washers with blue threadlocker (Loctite 242 or equivalent) as shown in figure 3-2. Torque AN3-3A bolts to 20-25 in-lb.



Figure 3-2

- 3.3. Fasten Cessna 172 Early Aft Pitch Bracket (P/N 1450-121) and C172 Early Fore Pitch Bracket Assembly (P/N 7100-100) to the assembly using 6 AN3-3A bolts as shown in figure 3-3. Torque AN3-3A bolts to 20-25 in-lb.



Figure 3-3

4. Prepare the aircraft for installation of the servo bracket assembly.
 - 4.1. Remove the tail fairings on both the left and right side of the aircraft as shown in figure 3-4.



Figure 3-4

- 4.2. Disconnect and remove the beacon resistor from the horizontal bulkhead.
5. Match drill bracket assembly to the horizontal bulkhead beneath the vertical stabilizer.
 - 5.1. Place bracket and servo assembly under the vertical stabilizer in the forward hole in the horizontal bulkhead with the wider bracket forward as shown in figure 3-5.

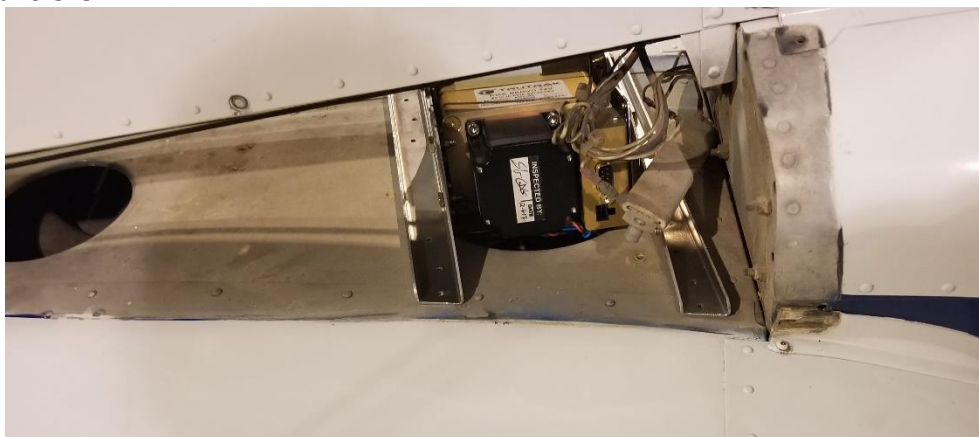

Figure 3-5

- 5.2. Position the bracket assembly so that it is equally spaced left to right from the edge of the horizontal bulkhead and forward and aft so that the servo is not in contact with the rim of the hole. See figures 3-6, 3-7, and 3-8.

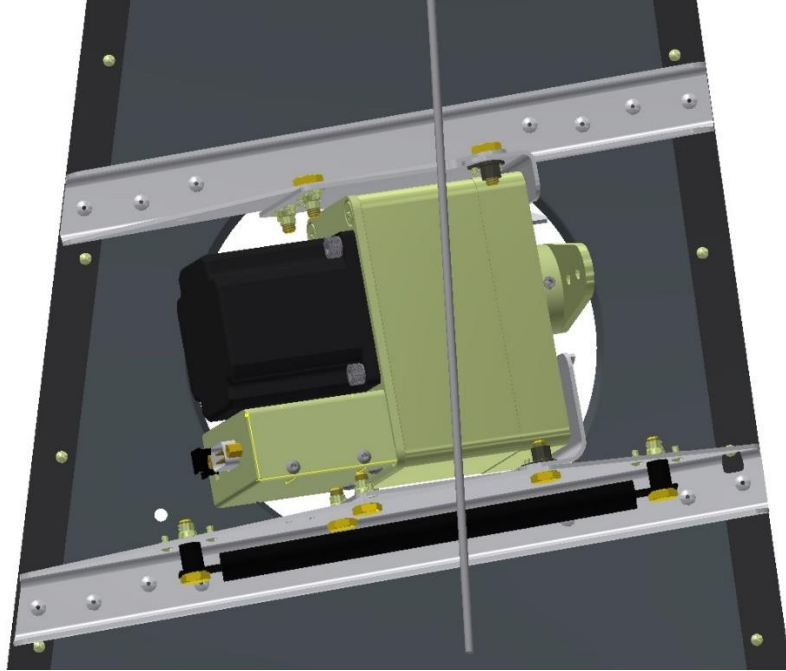

Figure 3-6

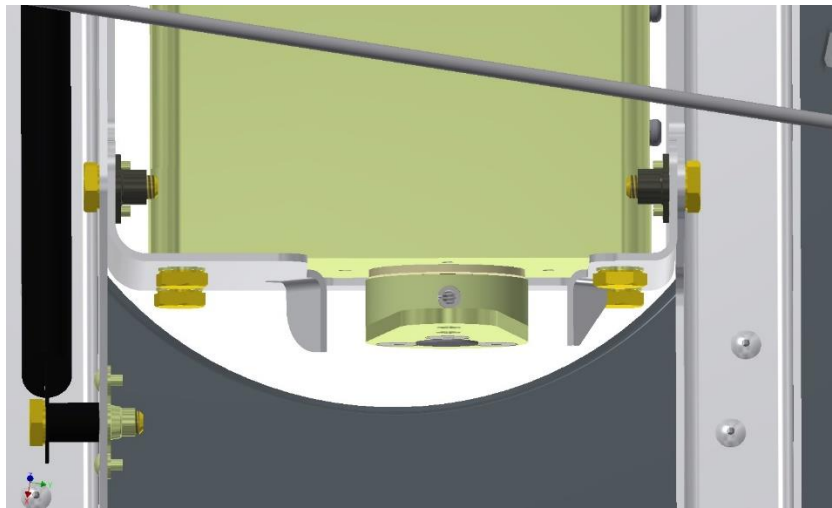

Figure 3-7

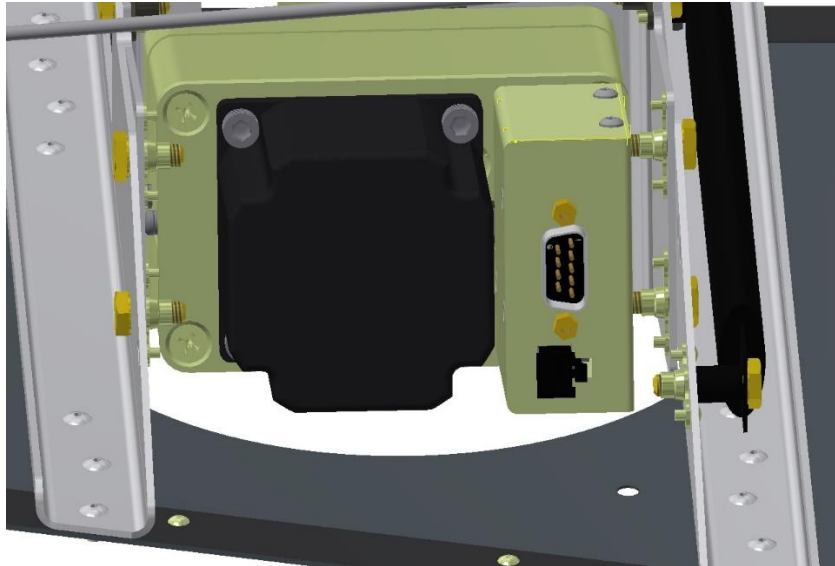

Figure 3-8

- 5.3. Match drill and Cleco clamp each of the 16 holes in the forward and aft bracket with the horizontal bulkhead with a #30 drill bit.
- 5.4. Remove Cleco clamps and remove bracket assembly.
- 5.5. Deburr drilled holes and remove shavings.
6. Place bracket assembly into position and rivet to horizontal bulkhead using 16 BSPQ-42 rivets.
7. Attach beacon resistor.
 - 7.1. Fasten beacon resistor to bracket assembly with electrical leads facing upward using 2 AN3-6A bolts torqued to 20-25 in-lb.
 - 7.2. Reattach beacon resistor electrical connections.
8. Prepare pushrod assembly for installation.
 - 8.1. The C172 Early Pitch Pushrod Assembly (P/N 7100-099) is a factory built assembly and should not be disassembled.
 - 8.2. Fully thread an AN315-4 nut on the MM-3-300 Rod End Bearing (P/N 2510-051).
 - 8.3. Thread the MM-3-300 Rod End Bearing (P/N 2510-051) half way into the C172 Early Pitch Pushrod Assembly (P/N 7100-099) as seen in figure 3-9.



Figure 3-9

- 8.4. Assemble the C172 Early Pitch Pushrod Assembly (P/N 7100-099) to the C172 Early Pitch Clamp Link Sensor Half (P/N 1420-227) using an AN4H-3A bolt with blue threadlocker (Loctite 242 or equivalent) and torque the bolt to 40-60 in-lb. The assembly should be oriented as shown in figure 3-10.



Figure 3-10

9. Attach the pushrod assembly to the servo assembly.
- 9.1. Fasten the MM-3-300 Rod End Bearing (P/N 2510-051) to the outer hole of the 1.5" PMA Servo Arm (P/N 1420-209) using 3 AN960-10, 1 AN970-3, 1 AN3-10A, and 1 MS20364-1032 in the configuration shown in figure 3-11.

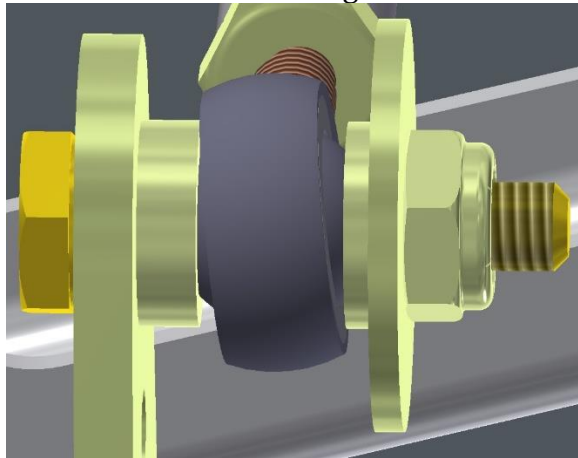

Figure 3-11

- 9.2. Torque the MS20364-1032 to 20-25 in-lb.
10. Install cable clamp to elevator cable
- 10.1. Hold the yoke in the full forward position and the servo arm 1/16 inch from the rear servo stop. See figure 3-12.

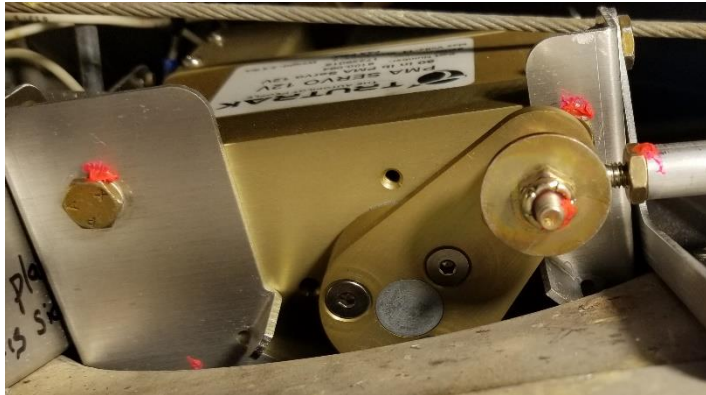

Figure 3-12

10.2. Clamp the elevator cable between the C172 Early Pitch Clamp Link Sensor Half (P/N 1420-227) and C172 Early Pitch Clamp Half (P/N 1420-228) and fasten with 8 AN3-5A and 8 MS20364-1032 as in figure 3-13.

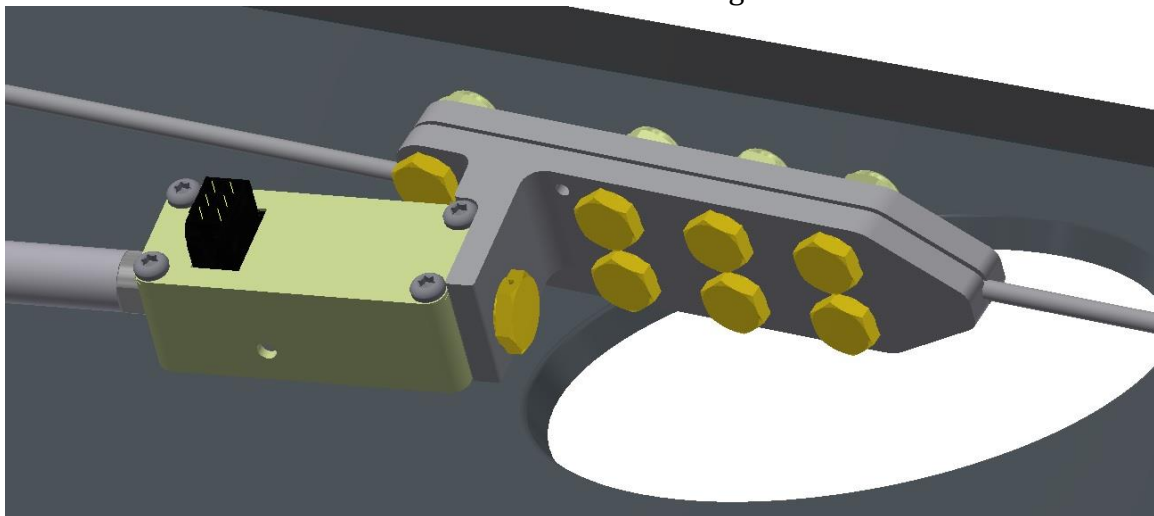

Figure 3-13

- 10.3. Tighten the fasteners on each side of the cable evenly so the spacing between each clamp half is even.
- 10.4. Torque each fastener to 20-25 in-lb.
- 10.5. Move the yoke to the full aft position and ensure the servo arm is not in contact with the forward servo stop. See figure 3-14. If the servo arm is contacting the servo stop perform factory setup procedure for elevator stops.

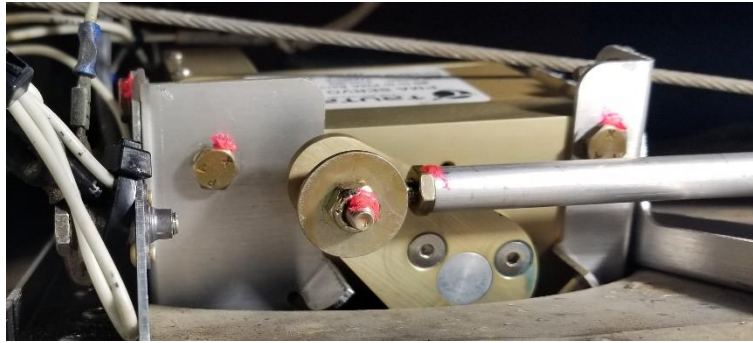

Figure 3-14

- 10.6. Lock wire the AN4H-4A bolt through the holes in both C172 Early Pitch Clamp Link Sensor Half (P/N 1420-227) and C172 Early Pitch Clamp Half (P/N 1420-228).
11. Install M22529/2-1R grommet edging on the forward edge of the lightening hole shown in figure 3-15. This lightening hole is approximately 2" aft of the rear of the servo bracket assembly.



Figure 3-15

12. Route the Microfit cable (P/N 6000-064) through the lightning holes in the bottom of the vertical stabilizer as shown in figure 3-15. Secure the Microfit cable in the locations shown in Figure 3-16, 3-17, 3-18 with 4 MS3367-1-0 cable ties.

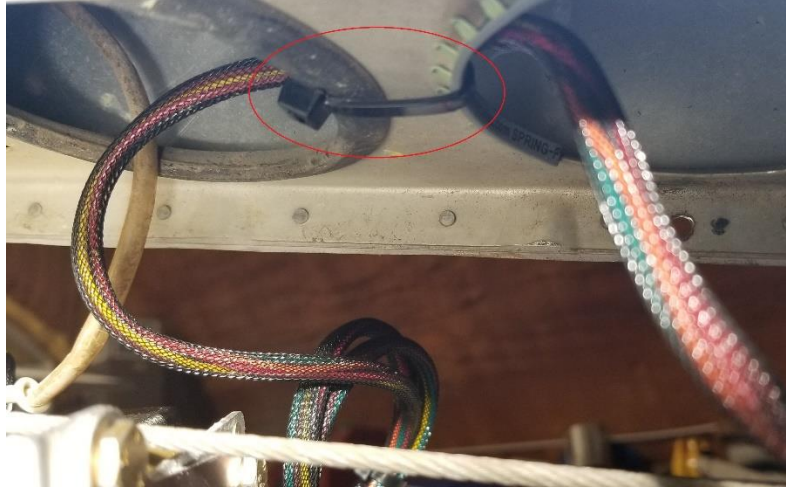

Figure 3-16

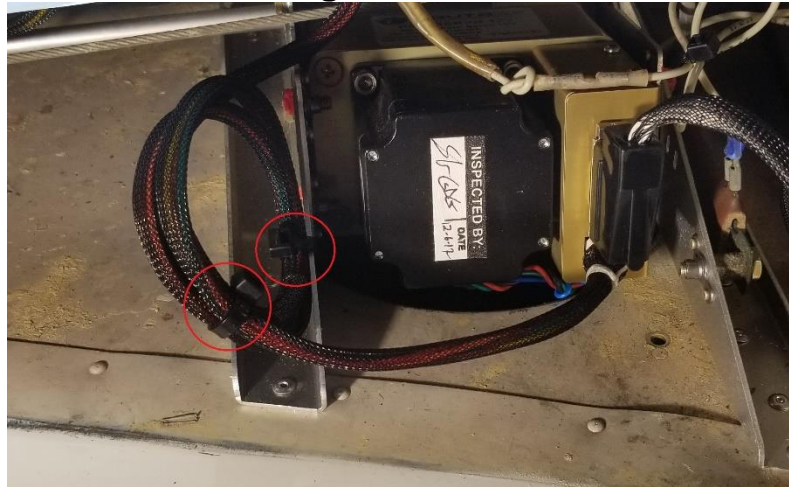

Figure 3-17

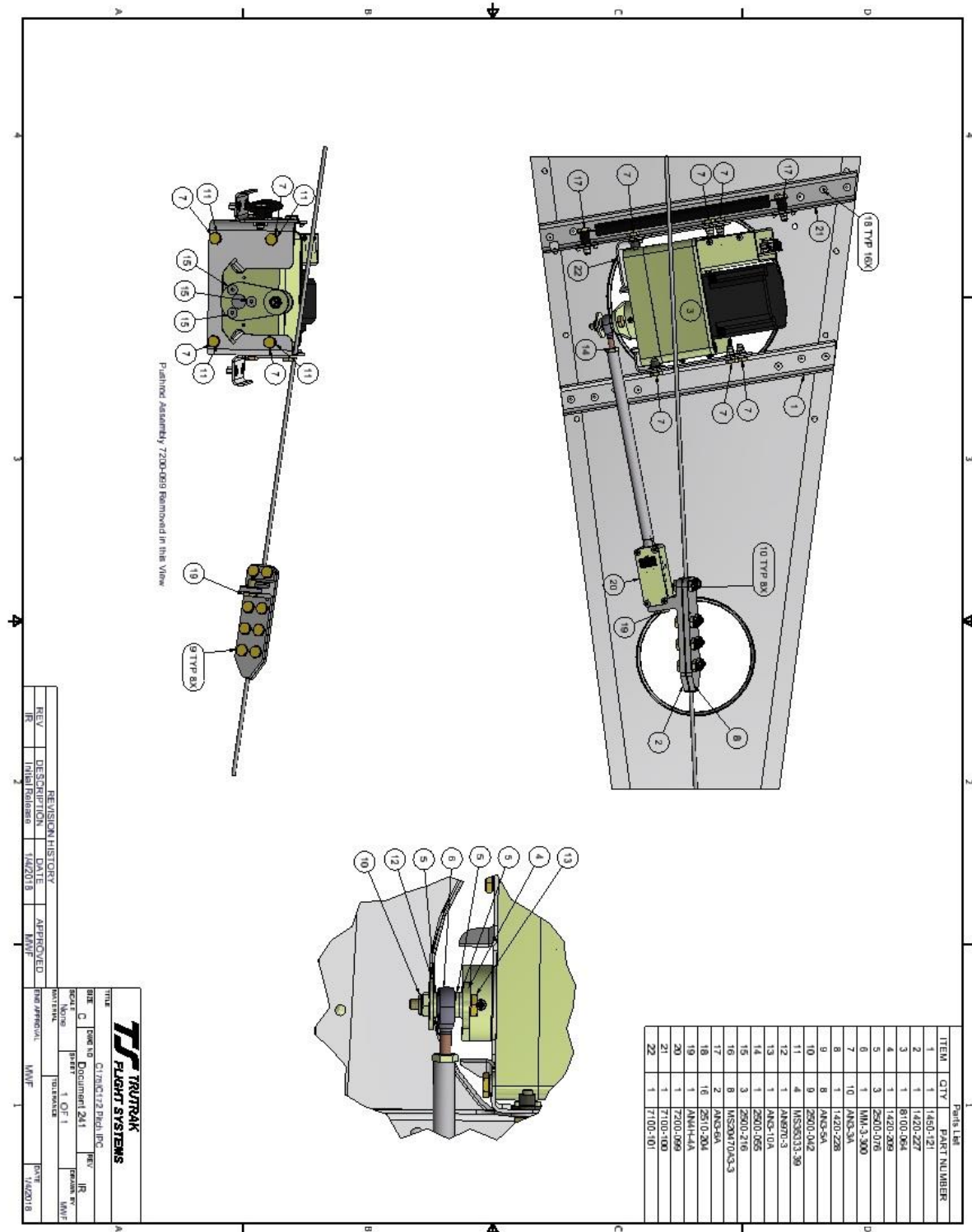

Figure 3-18



13. Ensure that the cable has adequate strain relief at both ends throughout the full range of travel. Maintain adequate clearance between the cable and all moving parts.
14. Secure right angle DB9 connector to pitch servo as seen in figure 3-17.
15. Insert Microfit cable into into mating connector on servo as seen in figure 3-17.
16. Secure any loose wires to prevent interference with any moving parts.
- 17. Apply torque seal to all bolts after final torquing is achieved.**

3.3. Cessna 175/172 All Models Vizion Pitch IPC



4. Cessna 175/172 All Models Wiring Harness Installation

4.1. Wiring Harness Materials List

Qty	Description	Part Number
1	Vizion Wiring Harness 25'	8220-033
1	Vizion 2" Controller OR Vizion 3" Controller OR Vizion Flat Pack Controller	8000-174 OR 8000-176 OR 8000-175
100	MS3367-1-0 Cable Tie	
1	Connector Backshell 9 Pin	2100-010
2	Connector D-sub Female 9 Pin Crimp	2100-044
16	Female Socket Crimp Connector D-sub	2100-045
1	Right Angle D-sub 9 Pin Backshell Kit	8210-011
1	Vizion Emergency Level Button Kit	8100-113
1	Vizion Limitations Placard	8300-092
17 IN	M22529/2-1R Grommet Edging	
1	5A AP circuit breaker (not supplied)	
1	Control Wheel Steering Switch (not supplied, but MUST be RED in color)	
1	AP Master Switch (not supplied)	
4	6-32 X 3/8" Instrument mounting screw (not supplied)	
N/A	Various terminals and pins for connection of power and GPS	
N/A	1/8"-27 NPT male fittings and tees for connecting the A/P pitot and static to the aircraft systems	

4.2. Wiring Harness / Controller Mounting Instructions

1. Begin by disconnecting the aircraft battery.
2. Select a mounting location for the autopilot controller.
 - 2.1. Consider the overall mounting depth of the controller with pitot, static, and electrical connections and allow clearance where necessary, especially surrounding the moving yoke assembly.
 - 2.2. Ensure that mounting location does not require autopilot servo lines to run near com antenna coax.
 - 2.3. Ensure that there is sufficient space near the autopilot controller to install the Vizion Limitations Placard (Trutrak P/N 8300-092)
3. Open required inspection panels and access panels for harness routing.
 - 3.1. Remove the right and left panel overlays and the left instrument panel.
 - 3.2. Remove interior trim from covering the right forward door pillar to expose the areas shown in figures 4-1 and 4-2.



Figure 4-1

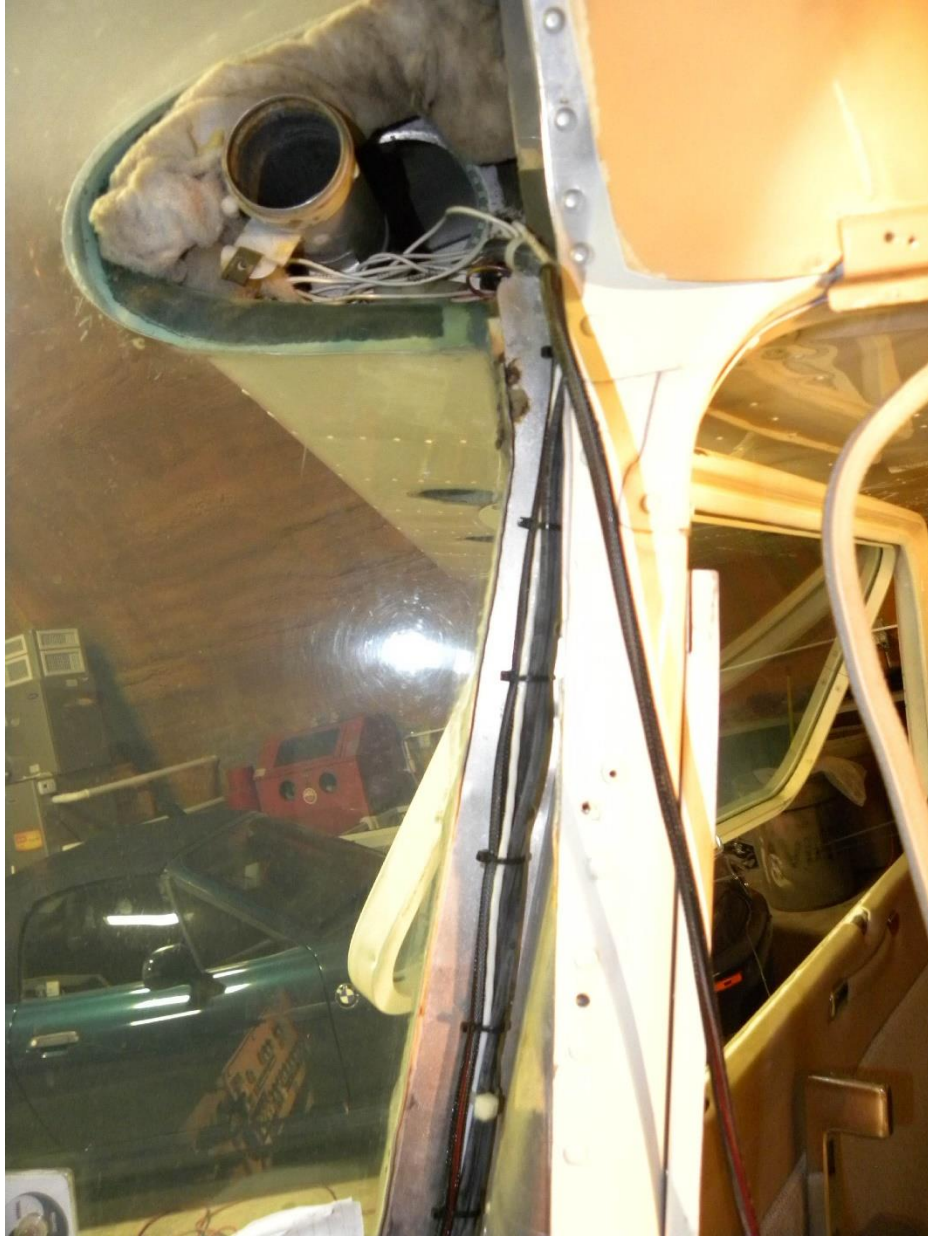

Figure 4-2

3.3. Remove the seats, carpet, and lower left kick panel to expose the wiring underneath the floor as seen in figure 4-3 and 4-4.



Figure 4-3



Figure 4-4

3.4. Remove baggage compartment bulkhead seen in figure 4-5.



Figure 4-5

3.5. Open inspection covers as shown in figure 4-6.



Figure 4-6

4. Begin routing wiring harness.
 - 4.1. Route the pitch (white) and roll (black) servo harnesses down the left side of the center stack as shown in figures 4-7 and 4-8. The blue line in Figure 4-7 shows the main autopilot bundle. The red line in figure 4-8 shows the roll servo harness and the green line shows the pitch servo harness.

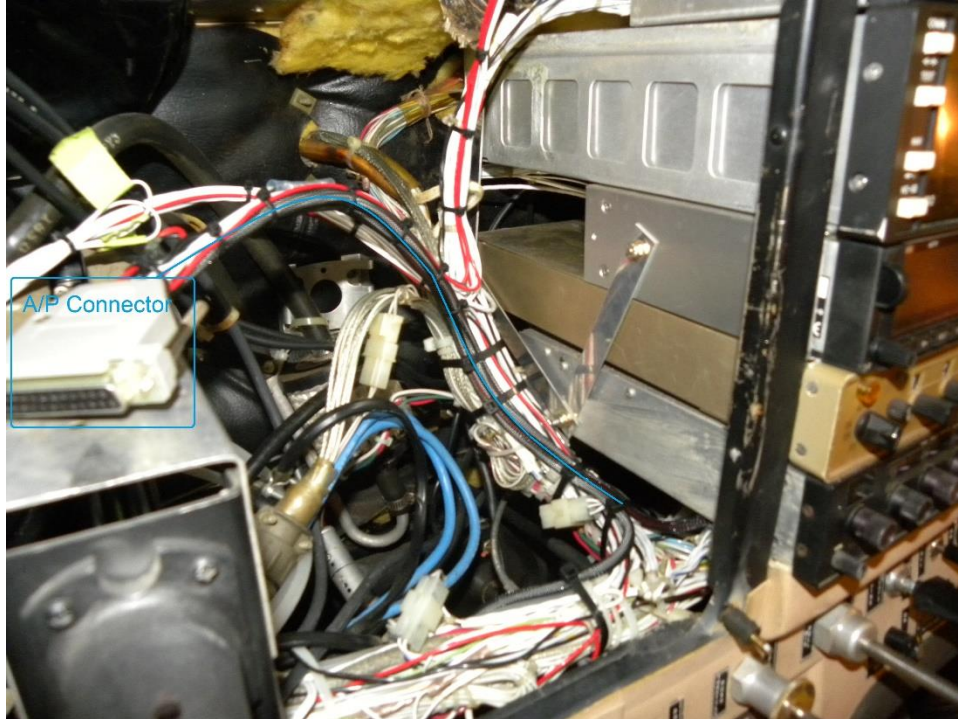

Figure 4-7

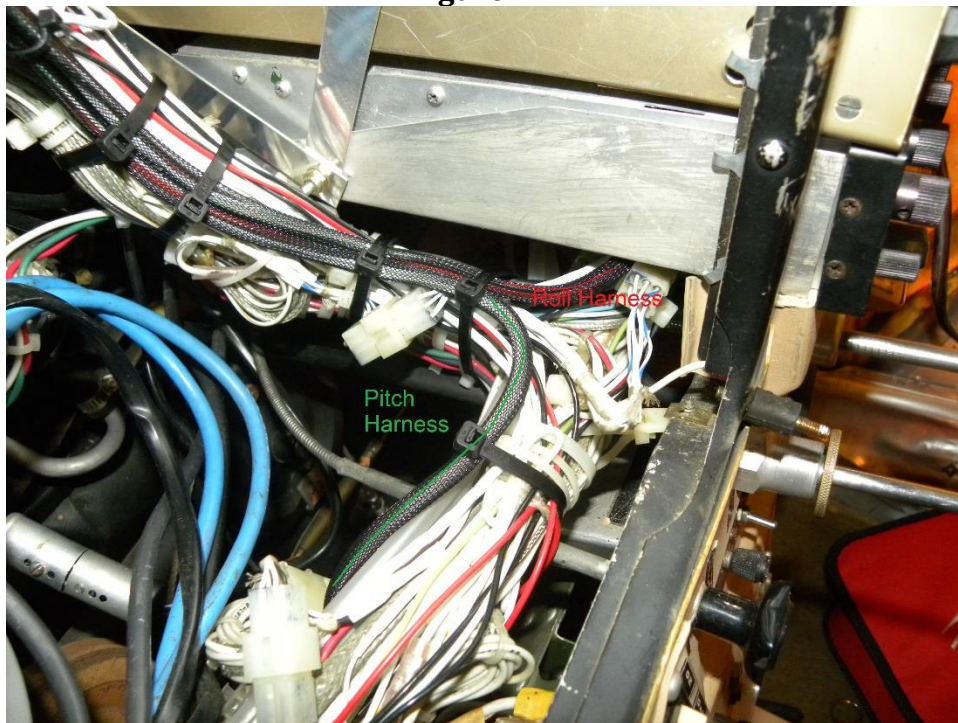

Figure 4-8

5. Continue routing wiring harness. The green line in Figure 4-9 shows the path the harness should take.
 - 5.1. Continue running the pitch servo wiring harness left over the yoke and down the left side of the as shown in figure 4-9.



Figure 4-9

- 5.2. Continue routing pitch servo harness underneath the floor following the existing wire bundle as seen in figure 4-10.



Figure 4-10

- 5.3. Continue routing under the the floor until the harness exits into the rear fuselage. Then route the harness to the left following the original wiring bundle as shown in figure 4-11.



Figure 4-11

- 5.4. Continue routing the harness up the side of the fuselage on the outside of the brackets for the hat rack as shown in figure 4-12.



Figure 4-12

5.5. Continue routing aft in the rear fuselage through the existing grommet in the middle former as shown in figure 4-13.



Figure 4-13

- 5.6. Route the harness through the lower grommet in the rear bulkhead as shown in figure 4-14.



Figure 4-14

- 5.7. Secure pitch servo harness with MS3367-1-0 Cable Ties every 6-12" ensuring that there is no interference with any moving parts.
6. Terminate the pitch servo wiring harness per the Vizion wiring diagram **USING OPTION B** in the Vizion PMA Installation Guide (TruTrak Doc. 166) using Right Angle D-sub 9 Pin Backshell Kit (P/N 8210-011).
7. Begin routing roll servo harness as shown in Figure 4-15. The red line shows the approximate path the harness should take.
- 7.1. Route the roll servo wiring harness under the avionics stack and over the right yoke to the right side of the panel.
- 7.2. Secure the harness to the existing wiring bundle using cable ties.

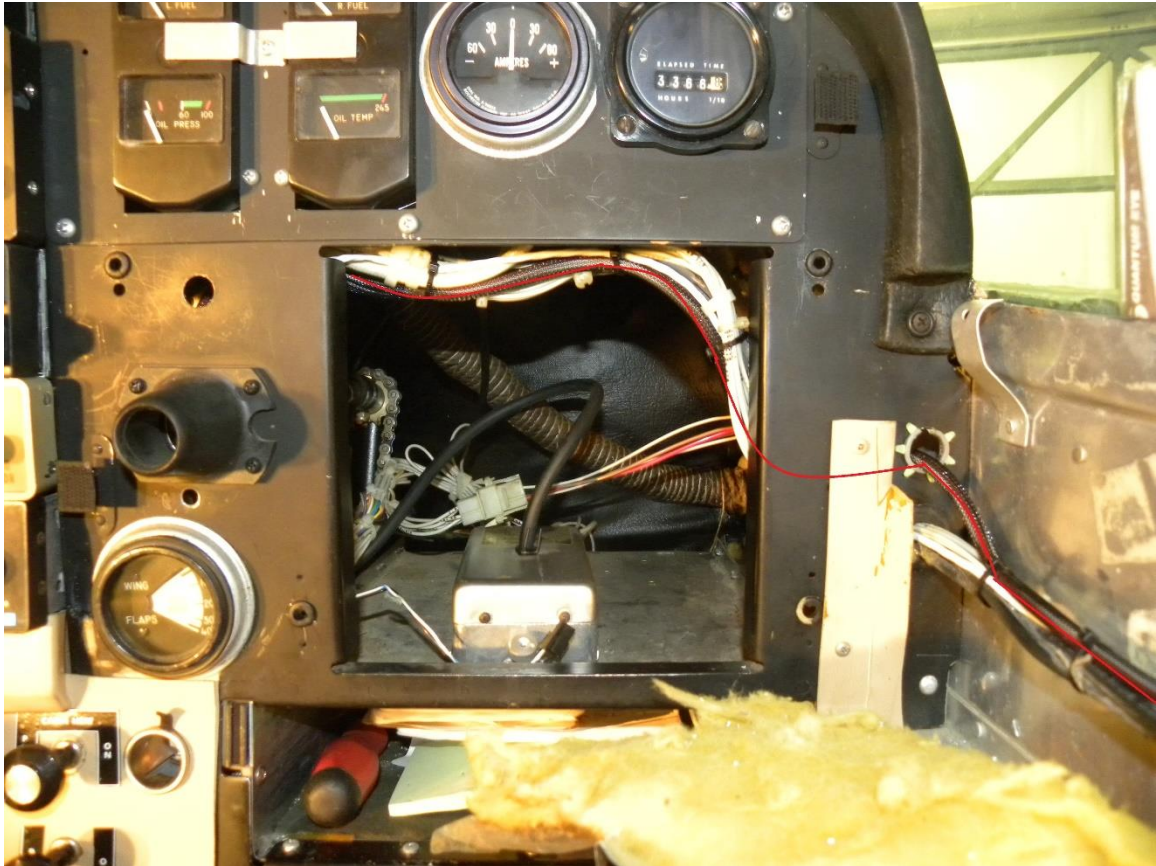

Figure 4-15

9. Continue roll servo harness routing. The red line in Figures 4-16, 4-17, and 4-18 shows the path the harness should take.
 - 9.1. Follow the existing wiring harness up the right front door post and through the grommets into the first inspection panel in the leading edge of the wing.



Figure 4-16



Figure 4-17



Figure 4-3

11. Continue roll harness routing in right wing.

- 11.1. Continue following the existing wiring harness through the grommets in the leading edge ribs past the second inspection hole. The red line in Figure 4-19 shows the pathway the harness should take.

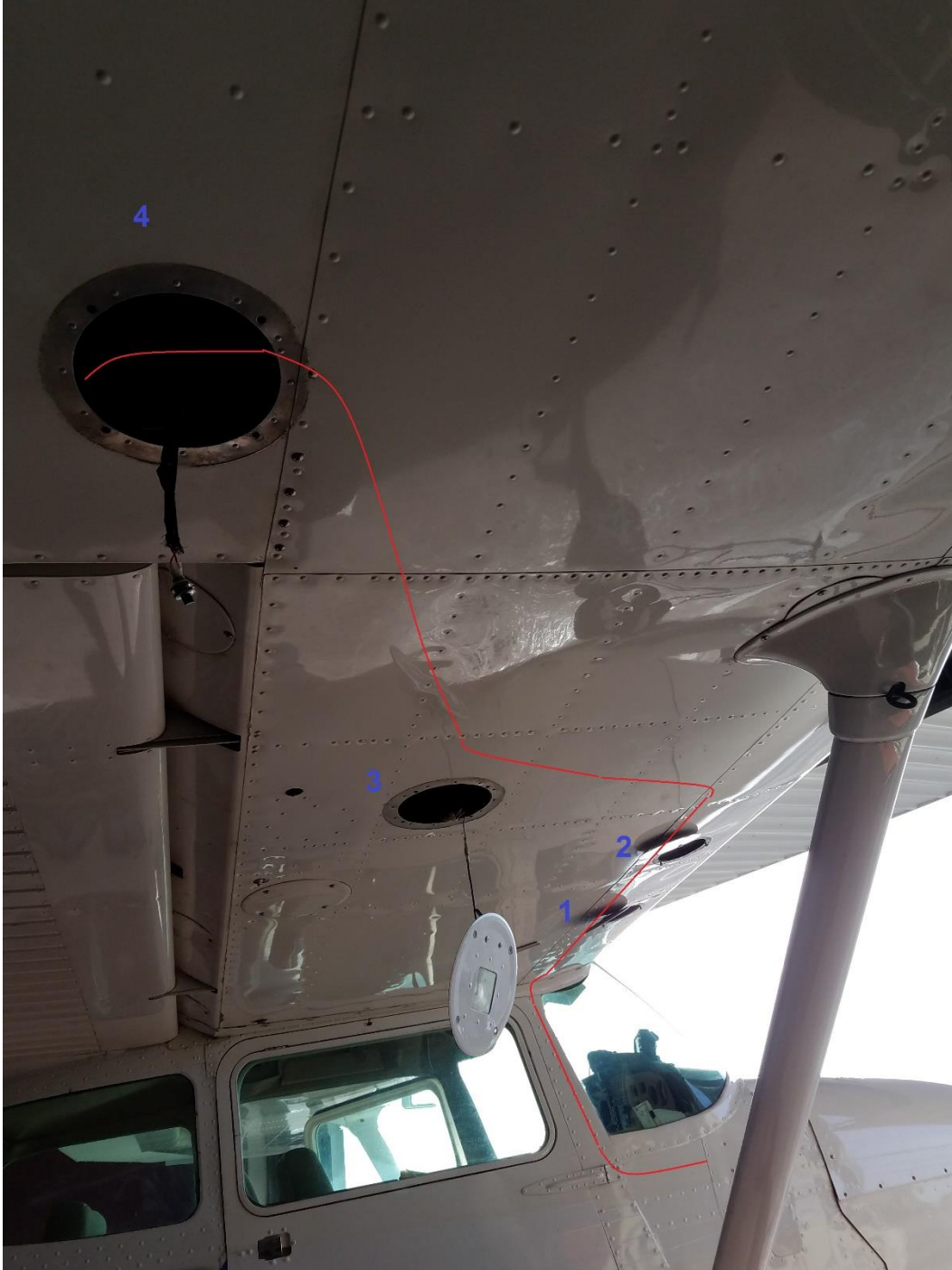

Figure 4-4

12. Install grommet edging on the lightning hole outboard of inspection hole 3 as shown in figure 4-20.



Figure 4-20

14. Continue installation of grommet edging.

- 14.1. Install grommet edging on the outer lightening hole forward of inspection hole 4 as shown in figure 4-21. The wiring harness must run through this lightening hole to prevent interference with servo and control cable movement.



Figure 4-21

15. Terminate the roll servo wiring harness per the Vizion wiring diagram in the Vizion PMA Installation Guide (TruTrak Doc. 166).
16. Reinstall cover plates on inspection holes 1, 2, and 3. Leave cover plate 4 open until the roll servo installation is complete.
17. Select appropriate mounting locations for the AP Master, AP Circuit Breaker, Emergency Level and control wheel steering switches. Connect these items per the Vizion wiring diagram in the Vizion PMA Installation Guide (TruTrak Doc. 166).
18. **All items in step 18 are required to be installed. The AP Master Switch, AP Circuit Breaker, and Control Wheel Steering switches must be labeled. The Control Wheel Steering Switch must be red.**

19. Connect GPS inputs per the Vizion wiring diagram in Vizion PMA Installation Guide (TruTrak Doc. 166)
20. Reinstall interior trim.
- 21. Conduct pitot / static check of aircraft system before opening any pitot/ static connections!**
22. Mount autopilot controller in panel using 4 6-32 X 3/8" screws. Connect wiring harness and connect pitot and static per Vizion PMA Installation Guide (TruTrak Doc. 166).
23. Install Vizion Limitations Placard (TruTrak P/N 8300-092) near the Vizion autopilot. A sample panel with potential placard location is shown below:

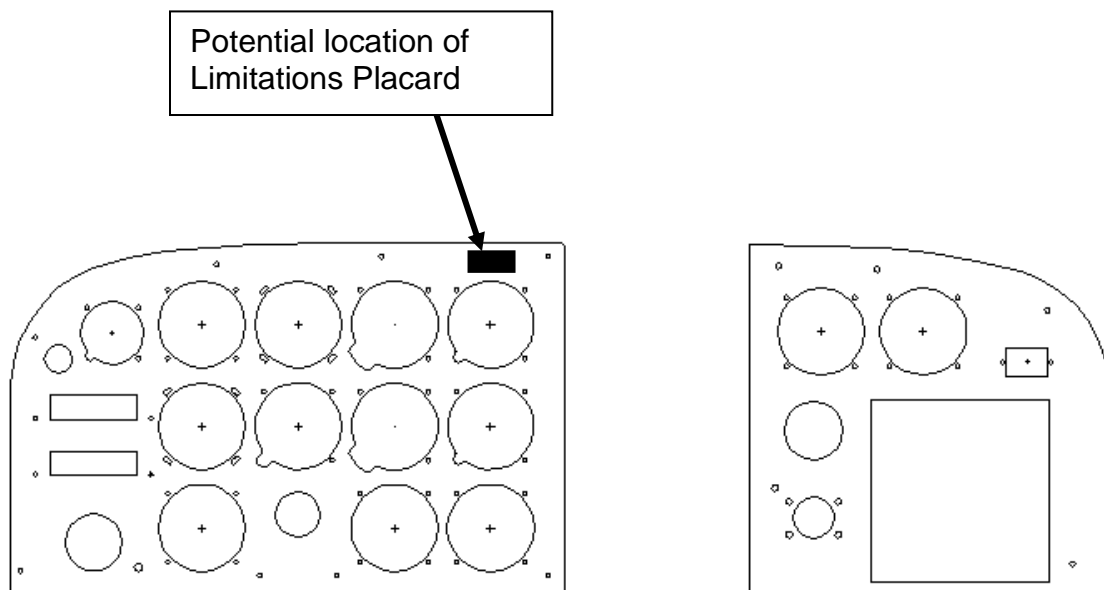

24. Reinstall the instrument panel and panel overlays.
25. If not already installed, install pitch and roll servos.
26. Reconnect battery.
27. Once autopilot settings are confirmed, perform autopilot system test per the Vizion PMA Installation Guide (TruTrak Doc. 166).

5. Cessna 175/172 All Models Autopilot Settings

Once all wiring is complete, verified, and the GPS setup has been completed (Vizion PMA Installation Guide (TruTrak Doc. 166)), follow the steps below to verify proper autopilot settings.

THIS STEP MUST BE COMPLETED PRIOR TO GROUND CHECK AND FLIGHT CHECK!!!

5.1. Lateral Autopilot Settings

- 1) PRESS and HOLD KNOB
- 2) Apply power to autopilot and GPS
- 3) Release KNOB.
- 4) PRESS KNOB to advance to min backlight
- 5) PRESS KNOB to advance to SETUP ENABLE.
- 6) ROTATE KNOB to select a value of **10**.
- 7) PRESS KNOB to exit.
- 8) PRESS and HOLD MODE button until LAT ACTIVITY is shown.
- 9) ROTATE KNOB to select a LAT ACTIVITY of **17**
- 10)PRESS ALT button to advance to next setup screen.
- 11)ROTATE KNOB to select a BAUD that matches the baud rate of the GPS (this will be either **4800** or **9600**).
- 12)PRESS ALT button to advance to next setup screen.
- 13)ROTATE KNOB to select a BANK ANGLE of **MED**.
- 14)PRESS ALT button to advance to next setup screen.
- 15)ROTATE KNOB to select a MICROACTIVITY of **10**.
- 16)PRESS ALT button to advance to next setup screen.
- 17)ROTATE KNOB to select a GPSS GAIN of **16**.
- 18)PRESS ALT button to advance to next setup screen.
- 19)ROTATE KNOB to set ROLL REV to **Y**.
- 20)PRESS KNOB exit lateral setup and return to the home screen.
- 21)PRESS ALT AND HOLD alt button until VRT AVTIVITY is shown.
- 22)WHILE CONTINUING TO HOLD ALT, PRESS MODE.
- 23)RELEASE MODE AND ALT.
- 24)PRESS MODE until MAC is displayed.
- 25)ROTATE KNOB to set MAC to **2**.
- 26)PRESS KNOB to exit menu and return to home screen.
- 27)Do not remove power from autopilot.



5.2. Vertical Autopilot Settings

- 1) PRESS and HOLD ALT button until VRT ACTIVITY is shown.
- 2) ROTATE KNOB to select a VRT ACTIVITY of **21**.
- 3) PRESS ALT button to advance to next setup screen.
- 4) ROTATE KNOB to select a MIN AIRSPD of (Refer to aircraft POH and set a value equal to 1.3 V_s in knots).
- 5) PRESS ALT button to advance to next setup screen.
- 6) ROTATE KNOB to select a MAX AIRSPD of (Refer to aircraft POH and set a value equal to 0.9 V_{NE} in knots).
- 7) PRESS ALT button to advance to next setup screen.
- 8) ROTATE KNOB to select a PITCH REV of **Y**.
- 9) PRESS ALT button to advance to next setup screen.
- 10) ROTATE KNOB to select a STATIC LAG of **0**.
- 11) PRESS ALT button to advance to next setup screen.
- 12) ROTATE KNOB to select a MICROACTIVITY of **5**.
- 13) PRESS ALT button to advance to next setup screen.
- 14) ROTATE KNOB to select a HALF STEP of **N**.
- 15) PRESS KNOB exit vertical setup and return to the home screen.
- 16) Cycle power on the autopilot.



TruTrak Flight Systems, Inc.