



October 5, 2020

ADDENDUM No. 1

Mossyrock Fire Station Phase 2 – Project No. MSR20-0213

This Addendum forms a part of the Contract Documents and modifies the original Contract Documents as described. There are 3 pages to this addendum including all attachments. This Addendum is issued to all known Plan Holders.

1. Update to plan and plumbing schedule in accordance with Mechanical, Electrical, and Plumbing addendum. See Sheets listed below for specific information. Changes to plan and plumbing schedule are limited to the following item: removal of the water heater (noted as plumbing fixture P4) which was previously located in Room 116. See Mechanical, Electrical, and Plumbing drawings for specifics about tying into existing hot water and hot water recirculation lines.

ARCHITECTURAL DRAWINGS

1. Sheet A-201 - Plans: REPLACE drawing with the attached revised Sheet A-201.
2. Sheet A-801 - Schedules: REPLACE drawing with the attached revised Sheet A-801.

PLAN LEGEND

- ▲ ARROW INDICATES PRIMARY BUILDING ENTRANCE
- ① A101 SECTION MARKER, NUMBER BELOW INDICATES PAGE WHERE SECTION CAN BE FOUND, NUMBER ABOVE INDICATES THE SECTION LOCATION ON THE PAGE.
- ① A101 DETAIL MARKER, NUMBER BELOW INDICATES PAGE WHERE DETAIL CAN BE FOUND, NUMBER ABOVE INDICATES THE DETAIL LOCATION ON THE PAGE.
- ① A101 INTERIOR ELEVATION MARKER, NUMBER IN CENTER INDICATES PAGE WHERE DETAIL CAN BE FOUND, NUMBER BY ARROW INDICATES THE DETAIL NUMBER.
- ◇ INDICATES WINDOW TYPE, SEE SCHEDULE SHEET A-801
- INDICATES DOOR TYPE, SEE SCHEDULE SHEET A-801
- INDICATES WALL TYPE, SEE DETAILS SHEET A-601

GENERAL NOTES

1. DIMENSIONS TO FACE OF STUD UNLESS NOTED OTHERWISE.
2. GENERAL CONTRACTOR TO VERIFY EXISTING CONDITIONS AND MEASUREMENTS PRIOR TO CONSTRUCTION.
3. ACCESSIBLE UNISEX RESTROOM LOCATED IN EXISTING BUILDING. PROVIDE CLEAR DIRECTIONAL SIGNAGE TO LOCATION.
4. DIMENSIONS TO DOOR CENTERLINES WHERE NOTED. SEE INTERIOR ELEVATIONS SHEET A-701 FOR OTHER DOOR LOCATIONS.

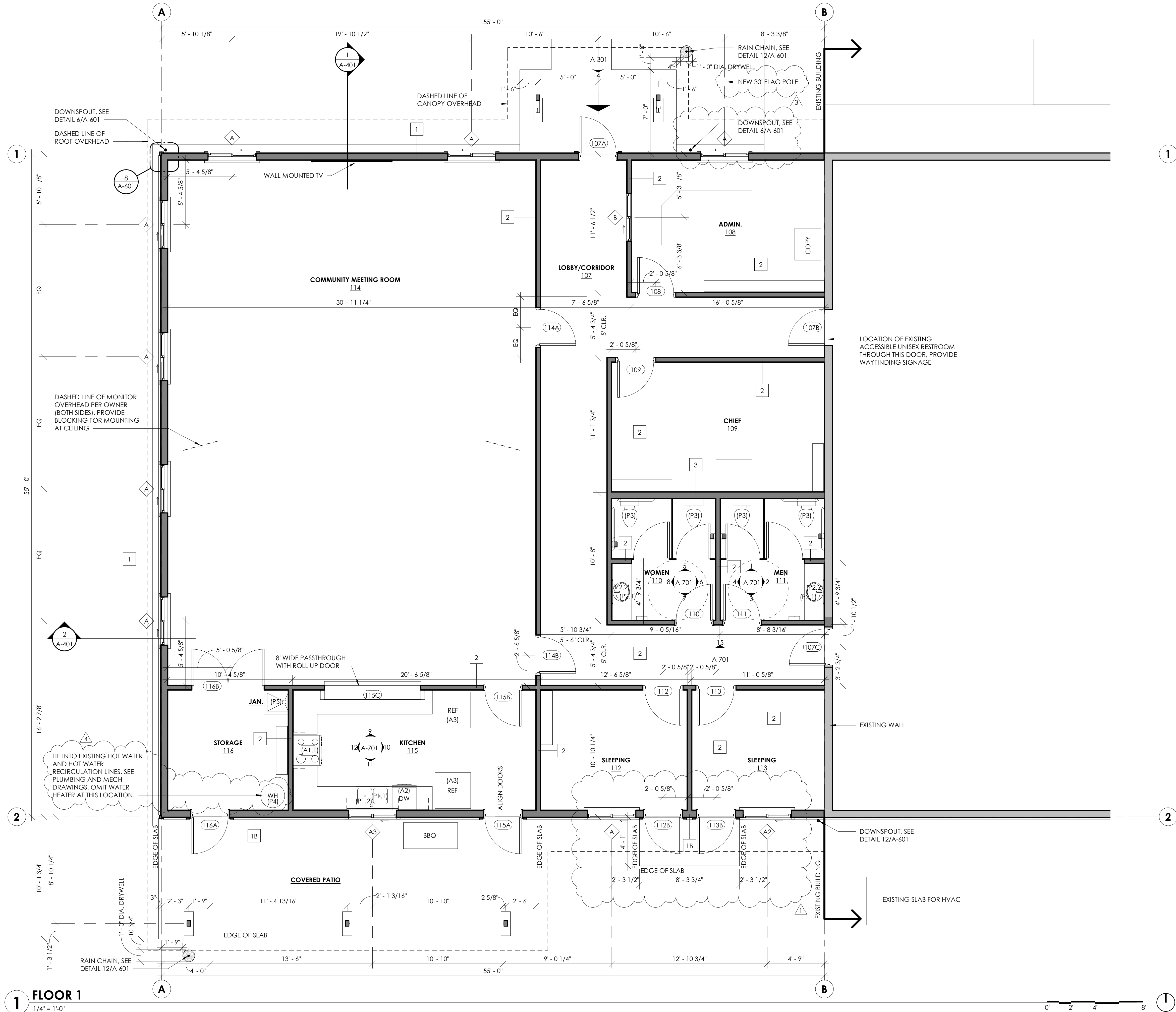

1 FLOOR 1
1/4" = 1'-0"

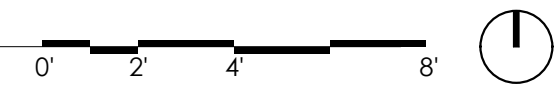

THOMAS
architecture studios
525 COLUMBIA ST. | OLYMPIA, WA 98501
360.915.8775 | tasoympia.com

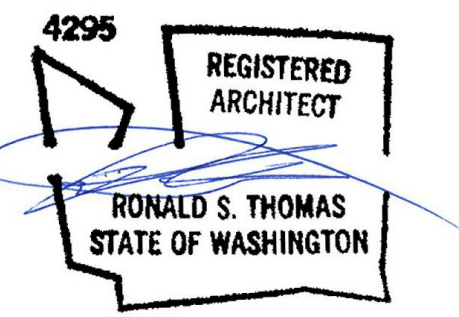

LEWIS COUNTY FIRE DISTRICT #3
MOSSYROCK FIRE STATION
 238 MOSSYROCK ROAD E | MOSSYROCK, WA 98564

Project No: 1927
BUILDING PERMIT SUBMITTAL
 APRIL 15, 2020

1	REVISION 1	6/11/2020
3	REVISION 3	9/18/2020
4	REVISION 4	10/5/2020

PLANS

A-201

All material herein constitutes the original and unpublished work of the architect and may not be used, duplicated, or disclosed without the written consent of the architect. Copyright © 2020 by Thomas Architecture Studio. All rights reserved.

ABBREVIATIONS

ACT	ACOUSTICAL CEILING TILE
CONC	CONCRETE
CPT	CARPET
EX	EXISTING
GWB	GYPSUM WALL BOARD
HM	HOLLOW METAL
MTL	METAL
PC	POLISHED CHROME (PER MANUFACTURER)
P-LAM	PLASTIC LAMINATE
PT	PAINT
RBR	RUBBER
SS	STAINLESS STEEL
SV	SHEET VINYL
VYL	VINYL
WD	WOOD
WGWB	WATER RESISTANT GYPSUM WALL BOARD
WHT	WHITE (PER MANUFACTURER)

WINDOW TYPES

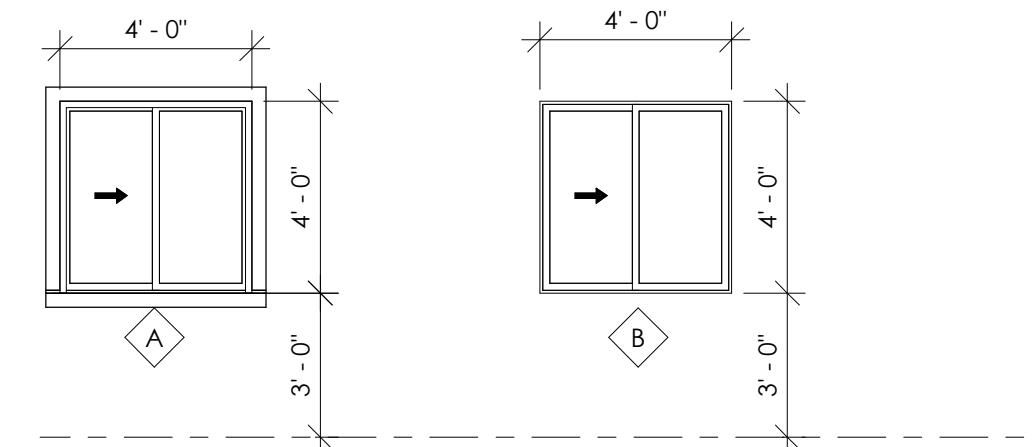

WINDOW SCHEDULE

MARK	SIZE	MAT/FIN	MANUF.	MODEL	OPERATION	COUNT	REMARKS
A	48" x 48"	VYL, WHT	MILGARD	TRINSIC	OPERABLE	9	EXTERIOR SLIDER, TO MATCH EXISTING, TRIM PER DETAILS
A2	48" x 48" R	VYL, WHT	MILGARD	TRINSIC	OPERABLE	1	EXTERIOR SLIDER, REUSE FROM BUILDING, TRIM PER DETAILS
A3	48" x 48"	VYL, WHT	MILGARD	TRINSIC	OPERABLE	1	EXTERIOR SLIDER, TO MATCH EXISTING, NO INTERIOR TRIM
B	48" x 48"	VYL, WHT	MILGARD	TRINSIC	OPERABLE	1	INTERIOR SLIDER, SILL PER DETAIL 7/A-602

DOOR TYPES

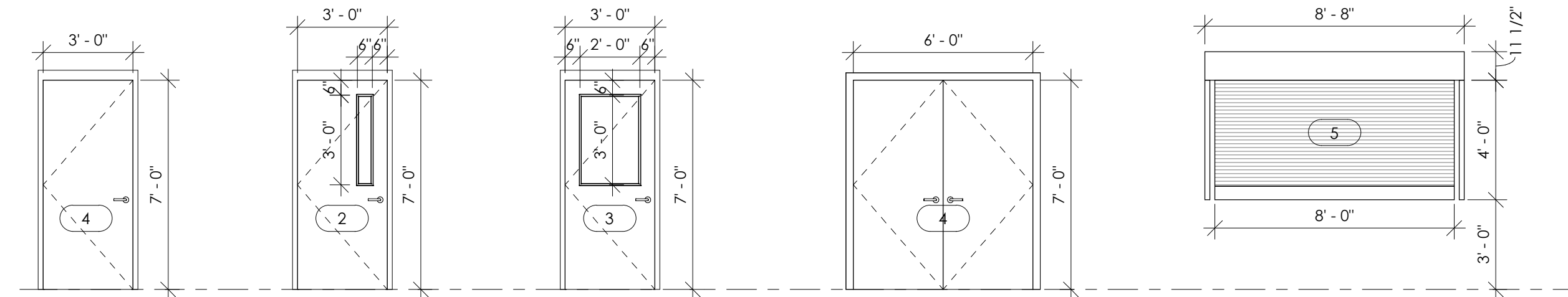

DOOR SCHEDULE

NO.	SIZE	TYPE	MAT/FIN	PAINT COLOR	MANUF.	MODEL/TYPE	REMARKS
107A	36" x 84" W/ 24" WIDE LITE	3	HM, PT	SW0024	CURRIES	607 SERIES, HG	VISION PANEL PER DIMENSIONS
107B	36" x 84" EXISTING	EX	EX	EX	EX	607 SERIES, F	DOOR TO REMAIN
107C	36" x 84"	1	HM, PT	SW0024	CURRIES	607 SERIES, F	NO VISION PANEL, INSTALL IN DEMOLISHED WINDOW OPENING
108	36" x 84"	1	HM, PT	SW0024	CURRIES	607 SERIES, F	
109	36" x 84"	1	HM, PT	SW0024	CURRIES	607 SERIES, F	
110	36" x 84"	1	HM, PT	SW0024	CURRIES	607 SERIES, F	
111	36" x 84"	1	HM, PT	SW0024	CURRIES	607 SERIES, F	
112	36" x 84"	1	HM, PT	SW0024	CURRIES	607 SERIES, F	
112B	36" x 84"	1	HM, PT	SW0024	CURRIES	607 SERIES, F	NO VISION PANEL, EXTRA 1/2" DEPTH ON FRAME
113	36" x 84"	1	HM, PT	SW0024	CURRIES	607 SERIES, F	
113B	36" x 84"	1	HM, PT	SW0024	CURRIES	607 SERIES, F	NO VISION PANEL, EXTRA 1/2" DEPTH ON FRAME
114A	36" x 84"	1	HM, PT	SW0024	CURRIES	607 SERIES, F	
114B	36" x 84"	1	HM, PT	SW0024	CURRIES	607 SERIES, F	
115A	36" x 84" W/ 6" WIDE LITE	2	HM, PT	SW0024	CURRIES	607 SERIES, FNV1	VISION PANEL PER DIMENSIONS, EXTRA 1/2" DEPTH ON FRAME
115B	36" x 84"	1	HM, PT	SW0024	CURRIES	607 SERIES, F	
115C	96" x 48"	5	MTL	N/A	OVERHEAD DOOR	650 SERIES	COUNTER DOORS 650 SERIES, OVERHEAD ROLLUP
116A	36" x 84"	1	HM, PT	SW0024	CURRIES	607 SERIES, F	NO VISION PANEL, EXTRA 1/2" DEPTH ON FRAME
116B	72" x 84"	4	HM, PT	SW0024	CURRIES	607 SERIES, F	

APPLIANCE SCHEDULE - OWNER SUPPLIED, CONTRACTOR INSTALLED

MARK	APPLIANCE TYPE	MANUFACTURER	MODEL	FINISH	REMARKS
A1.1	RANGE	SAMSUNG	NE59R4321SS/AA	SS	29-15/16"W x 28-7/8"D
A1.2	RANGE HOOD	SAMSUNG	NK36R5000WS/AA	SS	36"W
A2	DISHWASHER	SAMSUNG	DW80R7061US/AA	SS	24.9"W x 24.8"D
A3	REFRIGERATOR	SAMSUNG	RF261BEAESR/AA	SS	35-3/4"W x 35-3/4"D

PLUMBING SCHEDULE - SEE PLUMBING FOR ADD'L COMMENTS

MARK	FIXTURE TYPE	MANUFACTURER	MODEL	FINISH	REMARKS
P1.1	KITCHEN SINK	KOHLER	K-5267-1	SS	VERSE MODEL, 33"W x 22"D, STAINLESS STEEL FINISH
P1.2	FAUCET	KOHLER	K-596-CP	PC	SIMPLICE MODEL, SINGLE HOLE MOUNT, PULL-DOWN SPOUT
P2.1	BATHROOM SINK	KOHLER	K-2202-1	WHT	BROOKLINE MODE
P2.2	FAUCET	KOHLER	K-97060-4	PC	HINT MODEL, SINGLE HOLE MOUN
P3	TOILET	KOHLER	K-3551	WHT	
P4	WATER HEATER	RHEEM	GHE80SU/SS-130(A)	N/A	26-3/8" DIAMETER
P5	MOP SINK	FLORESTONE	MSR-2424	N/A	24" SQUARE

ROOM SCHEDULE - BASIS OF DESIGN

NO.	NAME	AREA	FLOOR	WALL			CEILING		REMARKS
				MAT.	FINISH	BASE	MAT.	FINISH	
107	LOBBY/CORRIDOR	439 SF	CONC	GWB	PT	RBR	GWB	GWB	
108	ADMIN.	176 SF	CONC	GWB	PT	RBR	GWB	GWB, ACT	GLUE UP ACOUSTICAL TILE PER MANUFACTURER
109	CHIEF	190 SF	CONC	GWB	PT	RBR	GWB	GWB, ACT	GLUE UP ACOUSTICAL TILE PER MANUFACTURER
110	WOMEN	87 SF	SV	WGWB	PT, SV	SV	GWB	GWB	SEE INTERIOR ELEVATIONS SHEET A-701
111	MEN	87 SF	SV	WGWB	PT, SV	SV	GWB	GWB	SEE INTERIOR ELEVATIONS SHEET A-701
112	SLEEPING	121 SF	CONC	GWB	PT	RBR	GWB	GWB	
113	SLEEPING	110 SF	CONC	GWB	PT	RBR	GWB	GWB	
114	COMMUNITY MEETING ROOM	1331 SF	CONC	GWB	PT	RBR	GWB	GWB, ACT	GLUE UP ACOUSTICAL TILE PER MANUFACTURER
115	KITCHEN	201 SF	CONC	GWB	PT, SV	RBR	GWB	GWB	SEE INTERIOR ELEVATIONS SHEET A-701
116	STORAGE	95 SF	CONC	GWB	PT	RBR	GWB	GWB	



THOMAS
architecture studios
525 COLUMBIA ST. | OLYMPIA, WA 98501
360.915.8775 | thosolympia.com

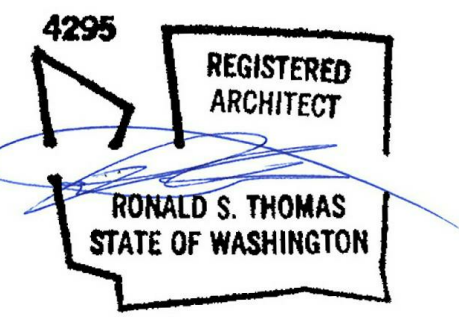

LEWIS COUNTY FIRE DISTRICT #3
MOSSYROCK FIRE STATION
238 MOSSYROCK ROAD E | MOSSYROCK, WA 98564

Project No: 1927
BUILDING PERMIT SUBMITTAL
APRIL 15, 2020

1 REVISION 1 6/11/2020
4 REVISION 4 10/5/2020

SCHEDULES

A-801

All material herein constitutes the original and unpublished work of the architect and may not be used, duplicated, or disclosed without the written consent of the architect. Copyright © 2020 by Thomas Architecture Studio. All rights reserved.