

# Lights Out Manufacturing

and a Compressor named  
"Dream Girl"

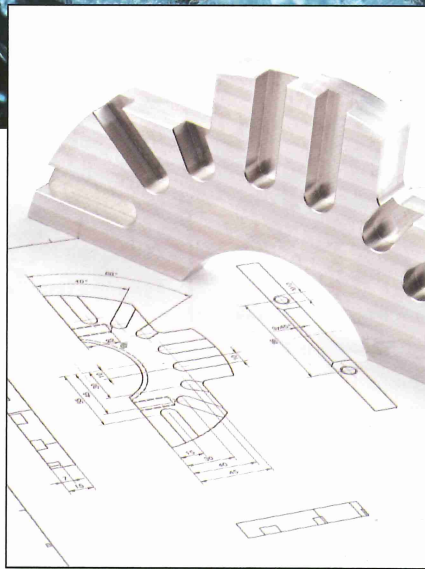

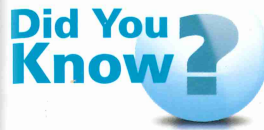

10 years ago...the top played song in the US was "In Da Club" by 50 Cent.

People name their children and pets. Some even name their boats, cars and motorcycles. So why wouldn't machine shop owners name the machines on their shop floor?

There's one who does. "My machines are my livelihood," says Eric Scobee, owner of EMSwiss LLC in Long Lake, Minnesota. "When we're adding a new member to our machine family, we give it a name. We could refer to machines with a number, I suppose, but names give them a bit more personality. It's also practical because when we refer to machines by name, there's no misunderstanding. We know exactly which one we're talking about."

Those machines-with-a-name at EMSwiss are at work, often around the clock, doing CNC machining with operations performed in as many as seven axes. "We can do high-precision turning, boring, drilling, milling – everything – all on one machine," says Scobee. "The parts we make are highly engineered and typically one inch in diameter and under. I can handle multiple ma-

chines myself, and once I have the process developed the machines can run 'lights out.' I set up cameras so I can see machines running and check their status remotely on a smart phone."

EMSwiss does prototyping and orders as small as 10 pieces, all the way up to volume production of 15,000 to 20,000 pieces a month. "We make a lot of parts for medical products, military applications, and parts that go into 4-wheel side-by-side ATVs and agriculture tractors," Scobee says. "We make parts used in crime scene forensics to help process DNA evidence. Most of our growth comes from word-of-mouth or from other machine shops that don't have swiss machining capabilities."

Professionally, Scobee focuses on machining as a process. "When I started machining, I didn't just do the work, I always tried to figure out the processes involved," he explains. "That got me involved in R&D and product development, and that led me to become a plant manager. I started teaching swiss machining classes at a technical school. At some point I asked myself, 'Can you make this part? Can you manage processes? Can you teach people how to do this?' It dawned on me that I needed to take the risk and go into business on my own, and in the fall of 2006 I got started. The first three or four years were a struggle, trying to get my name out and build my own customers, but then business started booming."





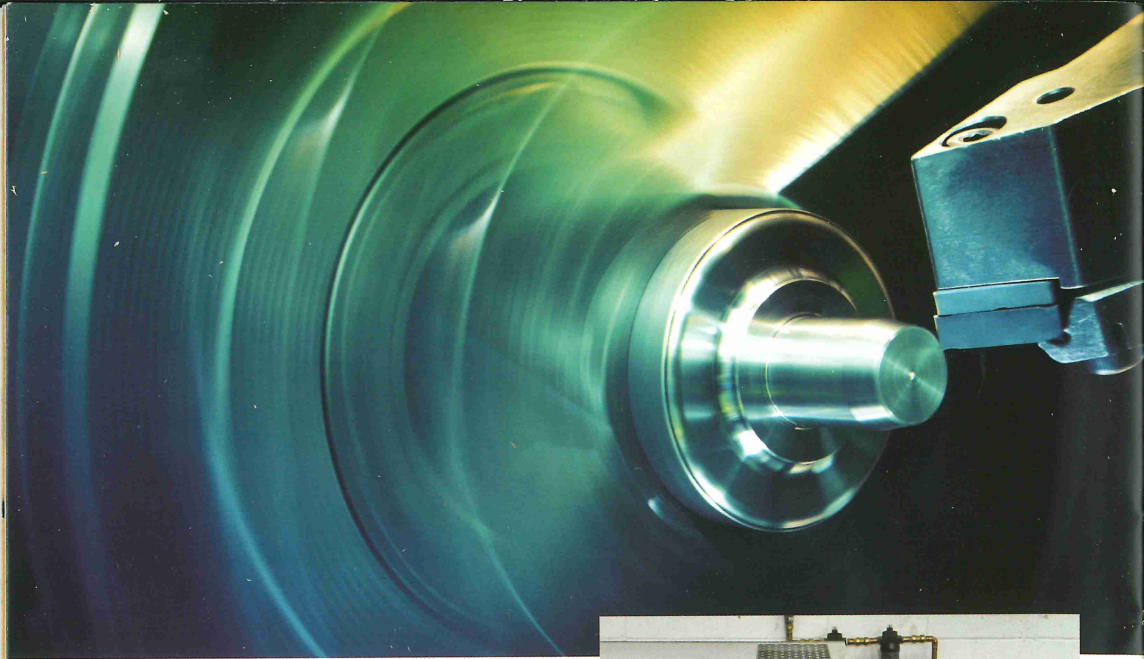

Business got so good that Scobee purchased another CNC machine. “Buying a new machine made it clear that we were going to need a better air compressor,” he recalls. “With my old reciprocating compressor the air wasn’t as clean as I needed. There were times when the collet that opens and closes on my machine was getting gummy in the switches from moisture and oil carryover in the air. Run dirty air in a \$200,000 machine? No thanks.”

In evaluating his options for a new compressor, Scobee consulted with another business owner who uses compressed air. “A buddy of mine in the concrete business had just bought a compressor,” Scobee says. “He does specialty concrete and has pumper trucks. He had been doing his research and told me that Atlas Copco is top-of-the-line. He said I should talk to Matt Oscarson, so I asked Matt to come out to my shop and give me his recommendation. I showed him how I was using air and answered lots of questions. I told him I buy quality and reliability so I don’t have to worry. My machines just have to work. My old compressor was really noisy so I told him a new one had to be quiet. And, of course, I wanted it as soon as possible.”



Oscarson recommended an Atlas Copco GA7 Full Feature tank mounted compressor. He described the performance and efficiency of the rotary screw compressor element and explained features including the MK5 Graphic control panel. He also explained about the reliability of Atlas Copco compressors and how the sound level would be much lower than the old compressor.

“It was really what I needed and he was able to get it to me quickly, so everything fell into place,” Scobee says. “I had the plumbing done so when the compressor arrived it was

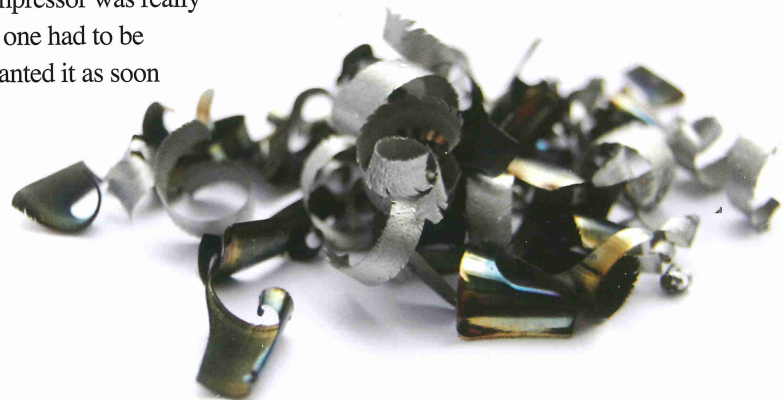

**"We make a lot of parts for medical products, military applications, and parts that go into 4-wheel side-by-side ATVs and agriculture tractors," Scobee says.**

pretty much plug-and-play. The technician got it running and set the pressure. I haven't had to mess with it yet. One thing I'm looking into is the factory maintenance program since my time is better spent figuring out a machining process."

Soon after the machine was installed, Oscarson returned to EMSwiss to check in with Scobee and make sure that everything was running right. "That's when I saw that Eric had labeled his new compressor *Dream Girl*," Oscarson recalls. "Eric says before he can do anything, he needs power and air. Well, now he has a reliable source of clean air. It's also a lot quieter than before, so now he can take cat naps on a cot he keeps in the shop while his machines are running through their processes."

Scobee admits that he did not fully appreciate the improvement in sound levels until the new compressor began operating. "Until I got the Atlas Copco, I never realized how noisy my other compressor was. The new machine operates at basically human voice level. When it's running, I know what 'quiet' is. I can get a little sleep between cycles without having the compressor wake me up. That's why she's my *Dream Girl*."

Kind of gives "lights out" manufacturing a whole new meaning.

#### **EMSwiss Materials Experience:**

- Various Steels
- Various Plastics
- Titanium
- Aluminum
- Brass
- Super Alloys

#### **EMSwiss Industries Served:**

- Military
- Aerospace
- Commercial
- Consumer
- Medical Device
- Medical Implant
- Private Arms



For more information: 617-716-1967

[emswissllc@aol.com](mailto:emswissllc@aol.com)