

Sullivan

Palatek®

Above & Beyond



Refrigerated Compressed Air Dryers

- SPRF - Standard Compressed Air Dryers**
- SPTX - Thermal Exchange Cycling Dryers**
- SPHT - High Inlet Temperature Dryers**

General Design Features

5 Year Warranty

Each Sullivan-Palatek Refrigerated Air Dryer is manufactured to the highest quality standard. In an effort to express this quality standard and distinguish our products from competitors, we have standardized on a 5-Year product warranty including 1-Year Labor

For the next 5-Years the Sullivan-Palatek warranty gives you the assurance that the purchase of a compressed air dryer will meet your needs without worry of costly equipment failure.

With continuous improvement of quality standards, along with engineering improvements that are advancing as fast as current technology, you can be assured that Sullivan-Palatek will provide you with a quality product for years of uninterrupted service.

Low Pressure Drops

All refrigerated compressed air dryers manufactured by Sullivan-Palatek are designed with pressure drops that range from 2.9 to 3.8 PSID. Competitive products can deliver pressure drops as high as 6.5 PSID. The addition of pressure drop can substantially increase system operating cost. Each (PSI) increase in systems pressure raises the required compressor horsepower by 0.5%. If a facility is required to raise discharge pressure by 3 PSI to overcome component restriction, 1.5% additional HP is required.

Assuming the facility operates a 100 HP compressor and has energy costs of \$0.06 kW/h, annual operational cost would increase \$588.00.

Sullivan-Palatek utilizes only environmentally friendly refrigerants. These low or non-ozone depleting products; HFC, have enabled a global transition away from environmentally destructive CFCs. Sullivan-Palatek refrigerated air dryers utilize HFC (R404A) & (R134A) refrigerant. Optional refrigerant types are available, consult your representative for details.



Sullivan-Palatek manufactures all of its compressed air dryers with pride in the USA. We offer our customers a steady stream of high quality products with proven performance that are reasonably priced; not based on fluctuating international finance. These points in conjunction with local engineering, maintenance, support, and readily available replacement components make Sullivan-Palatek an effective choice for compressed air components.

Sullivan-Palatek uses only diaphragm type solenoid valves for the electronic timed condensate drains. Diaphragm valves keep the main stream of condensate away from the internal movable piston. If particulate contaminates in the condensate fouls and restricts movement of the

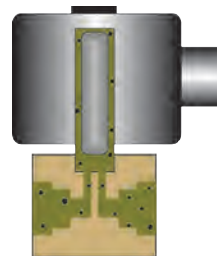

piston, the valve will fail. Diaphragm valves have much larger orifices and flow paths than industry standard direct acting valves. Larger orifices virtually eliminate the possibility of clogging a drain valve.

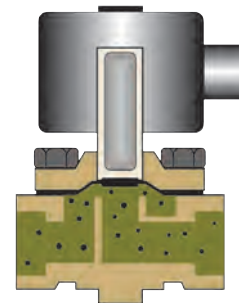

SPHT Series High Inlet Temperature Dryer

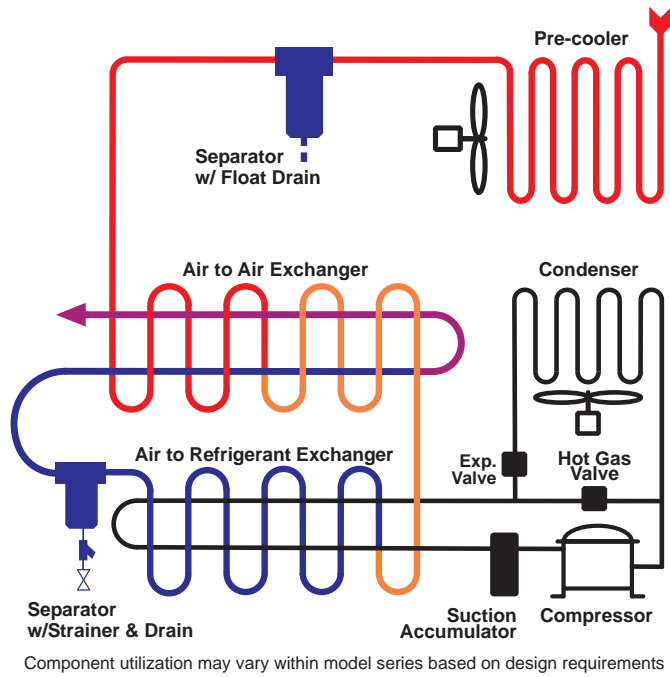

SPHT series delivers pressure dewpoints of 39°F. Many other high inlet temperature dryers offer only a 50°F dewpoint that can prove insufficient in many manufacturing processes. A 39°F pressure dewpoint provides compressed air that contains 33% less moisture than compressed air with a 50°F pressure dewpoint. The SPHT series is capable of flows rated for both 39°F or 50°F dewpoints.

A modulating thermostatic expansion valve gives a more effective refrigeration control over a wide span of operating conditions.

A hot gas bypass valve compensates for low load conditions preventing freeze-up.

Specifications & Dimensions

Model Number	Capacity in SCFM @				Refrigeration System		Available Voltage	In / Out Ports	Max. Inlet Pressure	Dimensions			Shipping Weight	
	50°F PDP		39°F PDP		HP	Watts				Height	Width	Depth		
	120 PSIG	100 PSIG	120 PSIG	100 PSIG										
SPHT-A1-116	28	24	23	20	1/5	376	120-1-60 230-1-60	N/A	230 PSIG	23	18	23	117	
SPHT-A2-116	36	30	30	25	1/4	451				3/4	23	18	23	120
SPHT-B1-116	50	43	42	36	1/3	576				3/4	35	19	23	183
SPHT-B2-116	80	67	66	56	1/2	776		3/4		35	19	23	195	
SPHT-C1-116	102	86	85	72	5/8	1045		1		42	22	29	285	
SPHT-C2-116	155	132	129	110	3/4	1135		1-1/2		42	22	29	298	

- Notes:
1. Capacity reflects a maximum 100°F inlet temperature and 100°F ambient.
 2. "□" Symbol reflects missing voltage designation.
 3. In/Out Ports are NPT unless otherwise specified.
 4. Refrigeration watts specified is an average of all power components through a fully loaded operational cycle
 5. Dimensions are in inches
 6. Shipping weight is in pounds
 7. Dimensions and specifications are subject to change without notice

Capacity Correction Table

Capacity Correction		Inlet Temperature		
		125°F	150°F	180°F
Ambient °F	100°F	1.18	1.10	1.00
	105°F	1.07	1.00	0.91
	110°F	0.97	0.90	0.82

To obtain flow capacities at conditions other than standard, locate the multiplier at the interception of actual operating conditions. Multiply the rated capacity of the selected dryer by the selected multiplier. The result is the corrected flow capacity. Capacity corrected flows over standard operating conditions will increase pressure drop.

SPRF Series Refrigeration Dryer

A modulating thermostatic expansion valve gives a more effective refrigeration control over a wide span of operating conditions. It prevents compressor failure due to liquid return commonly found in capillary tube designs.



An adjustable hot gas bypass valve compensates for low load conditions preventing freeze-up.

Suction accumulators prevent liquid return on cold starts and extend refrigerant compressor life.

Refrigeration suction and discharge service valves.

Models SPRF-295A and larger feature fan cycle controls standard.

Industrial duty all steel ergonomic cabinets with high quality powder coat finish.

All condensate drains are electronic timed solenoid type with isolation valve and cleanable Y-Strainer.



The SPRF series Compressed Air Dryer is UL listed and marked for both the US & Canadian markets as per ANSI/UL standard #1995.

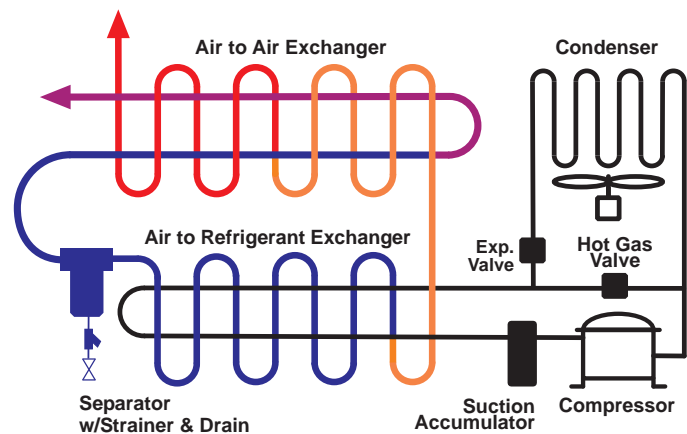

Component utilization may vary within model series based on design requirements

Model Number Breakdown

Series	Capacity	Cooling		Design Change		Voltage	
SPRF	XXXX	X		XX		XXX	
SCFM @ 120 PSIG 100°F Inlet 100°F Ambient	A	Air		Blank	NEMA 1	116	120-1-60
	W	Water	⊗	N4	NEMA 4	216	208/230-1-60
				P3	300 PSIG	236	208/230/3/60
				P5	500 PSIG	436	460-3-60
				SW	SS All Wetted	536	575-3-60
				RC	Remote Cond	115	100-1-50
							215
⊗ This symbol represents an optional design that is not available as a UL Listed product						235	200/240-3-50
						335	380/420-3-50

Specifications & Dimensions

Model Number	Capacity In SCFM @		Available Voltages			Refrigeration System		In / Out Ports	Maximum Pressure	Dimensions			Shipping Weight
	120 PSIG	100 PSIG				HP	Watts			Height	Width	Depth	
SPRF23A-116	23	20	120-1-60	Not Available	Not Available	1/6	255	3/4	230 PSIG	23	18	23	104
SPRF29A-116	29	25				1/5	360	3/4		23	18	23	111
SPRF47A-116	47	40				1/4	435	3/4		23	18	23	119
SPRF58A-116	58	50				1/3	560	3/4		23	18	23	124
SPRF88A-116	88	75				1/2	760	3/4		23	18	23	146
SPRF115A-□	115	100				5/8	1010	1		42	22	29	251
SPRF145A-□	145	125	230-1-60	Not Available	Not Available	3/4	1100	1	230 PSIG	42	22	29	261
SPRF175A-□	175	150				3/4	1100	1-1/4		42	22	29	268
SPRF235A-□	235	200				1	1360	1-1/4		42	22	29	272
SPRF295A-□	295	250				1-1/2	2292	1-1/2		49	34	35	410
SPRF350A-□	350	300				1-1/2	2292	1-1/2		49	34	35	420
SPRF470A-□	470	400				2	2639	2		49	34	35	470
SPRF580A-□	580	500	230/460/575-3-60	Not Available	Not Available	3	5199	2	150 PSIG	49	34	45	550
SPRF760A-□	760	650				3	5199	2		49	34	45	570
SPRF940A-□	940	800				4	6275	3		60	37	62	905
SPRF1175A-□	1175	1000				5	8302	3		60	37	62	1120
SPRF1400A-□	1400	1200				7	10703	3		60	37	62	1200
SPRF1760A-□	1760	1500				9	11477	4" Flg		70	43	68	2600
SPRF2055A-□	2055	1750				9	11477	4" Flg		70	43	68	2782
SPRF2350A-□	2350	2000				10	14705	4" Flg		70	43	68	3300
SPRF2650A-□	2650	2250				10	14705	4" Flg		70	43	68	3440

- Notes:
- Capacity reflects a maximum 100°F inlet temperature and 100°F ambient.
 - "□" Symbol reflects missing voltage designation.
 - In/Out Ports are NPT unless otherwise specified.
 - Refrigeration watts specified is an average of all power components through a fully loaded operational cycle
 - Dimensions are in inches
 - Shipping weight is in pounds
 - Dimensions and specifications are subject to change without notice

Model Capacity Correction Multiplier

Inlet Temperature		90°F			100°F			110°F			120°F		
Ambient Temperature		90°F	100°F	110°F	90°F	100°F	110°F	90°F	100°F	110°F	90°F	100°F	110°F
Inlet Air Pressure	70 PSIG	0.94	0.86	0.73	0.69	0.63	0.54	0.52	0.47	0.40	0.39	0.36	0.30
	80 PSIG	1.05	0.96	0.82	0.77	0.71	0.60	0.57	0.53	0.45	0.43	0.40	0.34
	90 PSIG	1.16	1.06	0.90	0.85	0.78	0.66	0.63	0.58	0.49	0.48	0.44	0.37
	100 PSIG	1.27	1.16	0.99	0.93	0.85	0.73	0.69	0.64	0.54	0.52	0.48	0.41
	110 PSIG	1.37	1.26	1.07	1.01	0.93	0.79	0.75	0.69	0.59	0.57	0.52	0.44
	120 PSIG	1.48	1.36	1.15	1.09	0.00	0.85	0.81	0.75	0.63	0.61	0.56	0.48
	130 PSIG	1.59	1.46	1.24	1.17	1.07	0.91	0.87	0.80	0.68	0.66	0.60	0.51
	140 PSIG	1.69	1.55	1.32	1.25	1.14	0.97	0.93	0.85	0.73	0.70	0.64	0.55
150 PSIG	1.80	1.65	1.40	1.33	1.22	1.03	0.99	0.91	0.77	0.75	0.68	0.58	

To obtain flow capacities at conditions other than standard (SCFM @ 120 PSIG, 100°F Inlet & 100°F Ambient), locate the multiplier at the intersection of actual operating conditions. Multiply the rated capacity of the selected dryer by the selected multiplier. The result is the corrected flow capacity. Flow rates in excess of specified due to capacity correction can result in increasing pressure drop.

SPTX Series Thermal Exchange Cycling Air Dryer

Rising energy costs have forced equipment efficiency and operating costs to become a significant factor in the purchase of new equipment. A basic non-cycling refrigerated air dryer matches the BTU capacity of the dryer refrigeration system with the BTU requirement of the compressed air load. This design is very efficient when the loads are balanced. In many applications, compressed air loads experience wide fluctuations that range from 0 to 100%. If the compressed air load falls, the refrigeration system must dump or waste energy to balance the system. The Sullivan-Palatek SPTX cycling refrigerated air dryer uses a fully loaded refrigeration system to store energy in the TRANS-TEMP ENERGY CELL. By operating the refrigeration system fully loaded; you maximize the operating efficiency and reduce your operational energy costs. When the ENERGY CELL reaches maximum charge, the refrigeration compressor CYCLES OFF; allowing the energy cell to continue providing the energy required for cooling and drying the compressed air system.



Adjustable Temperature Control

This feature allows the user to adjust the temperature of the TRANS-TEMP Energy Cell affecting the dryer dewpoint. Increasing dewpoint in applications that do not require optimum dewpoint suppression will further increase energy savings. The controller has a bright LED display that will read in °F or °C.

TRANS-TEMP Energy Cell

The TRANS-TEMP Energy Cell integrates non-hazardous, completely biodegradable fluids. This attains an ideal balance of thermal storage and thermal conductivity. The energy cell is encased in high density polyethylene plastic and is insulated to maintain energy efficiency.



Refrigeration System w/ Liquid Isolation System

This system isolates refrigerant liquid that has condensed and accumulated from the cold mass of the energy cell. It prevents the liquid from returning to the compressor, causing oil washout and premature compressor failure. This is a common problem with cycling dryers that do not have liquid isolation.

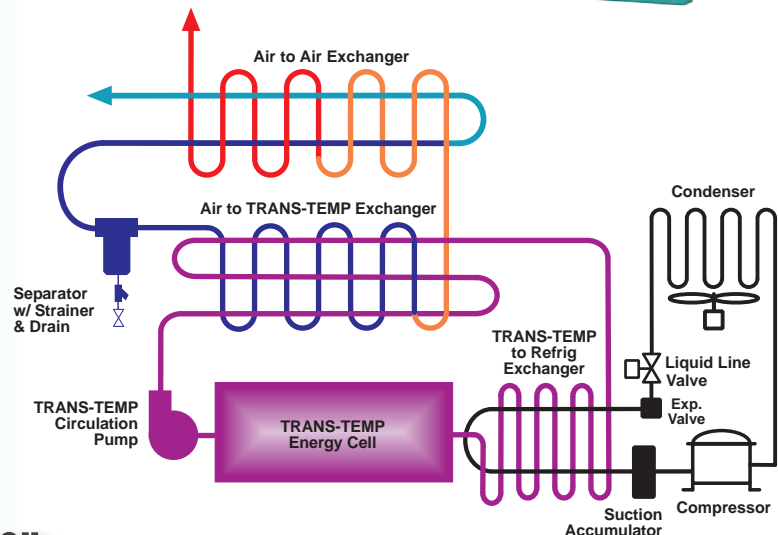

Component utilization may vary within model series based on design requirements

Operational Sequence

Saturated compressed air enters the dryer and is initially cooled in the air to air heat exchanger by the cold outgoing air. The TRANS-TEMP Fluid from the energy storage cell further cools the compressed air in the air to fluid heat exchanger. Liquid that has been condensed by the reduced air temperature is removed in the high efficiency separator. The cold air is then reheated as it pre-cools the inlet air in the air to air heat exchanger. The refrigeration system maintains the temperature in the energy storage cell with a microprocessor based controller and operates only as required. The energy cell is capable of maintaining dewpoint, allowing the refrigeration compressor to be cycled off and reducing required energy of operation.

Specifications & Dimensions

Model Number	Capacity in SCFM @		Available Voltages			Refrigeration System		In/Out Ports	Maximum Pressure	Dimensions			Shipping Weight
	120 PSIG	100 PSIG				HP	Watts			Height	Width	Depth	
	SPTX-120A-□	120	100	120V	230-1-60	N/A	5/8	930	1	230 PSIG	42	22	29
SPTX-150A-□	150	125	3/4				1030	1	42		22	29	370
SPTX-215A-□	215	180	1				1280	1-1/4	49		34	35	446
SPTX-270A-□	270	225	1-1/2	2234	1-1/2	49	34	35	475				
SPTX-360A-□	360	300	2	2399	1-1/2	49	34	35	635				
SPTX-480A-□	480	400	3	3574	2	49	34	45	750				
SPTX-600A-□	600	500	3	4647	2	49	34	45	875				
SPTX-725A-□	725	600	4	5144	2	60	37	62	1198				
SPTX-940A-□	940	800	5	7199	3	60	37	62	1416				
SPTX-1175A-□	1175	1000	7	9339	3	60	37	62	1534				
SPTX-1590A-□	1590	1350	9	10059	3	70	43	68	2150				
SPTX-2120A-□	2120	1800	10-1/2	13889	4" Flg	95	43	68	3425				
SPTX-2360A-□	2360	2000	12	15208	4" Flg	95	43	68	3579				
SPTX-2650A-□	2650	2250	13-1/2	17654	4" Flg	95	43	68	3778				

- Notes:
1. Capacity reflects a maximum 100°F inlet temperature and 100°F ambient.
 2. "□" Symbol reflects missing voltage designation.
 3. In/Out Ports are NPT unless otherwise specified.
 4. Refrigeration watts specified is an average of all power components through a fully loaded operational cycle
 5. Dimensions are in inches
 6. Shipping weight is in pounds
 7. Dimensions and specifications are subject to change without notice

Model Capacity Correction Multiplier

Inlet Temperature		90 °F			100 °F			110 °F			120 °F		
Ambient Temperature		90 °F	100 °F	110 °F	90 °F	100 °F	110 °F	90 °F	100 °F	110 °F	90 °F	100 °F	110 °F
Inlet Air Pressure	60 PSIG	0.75	0.69	0.63	0.60	0.55	0.50	0.40	0.37	0.34	0.15	0.14	0.13
	70 PSIG	0.86	0.79	0.72	0.69	0.63	0.57	0.46	0.42	0.38	0.17	0.16	0.15
	80 PSIG	0.96	0.88	0.80	0.76	0.70	0.64	0.52	0.48	0.44	0.20	0.18	0.16
	90 PSIG	1.07	0.98	0.89	0.85	0.78	0.71	0.58	0.53	0.48	0.22	0.20	0.18
	100 PSIG	1.16	1.06	0.96	0.93	0.85	0.77	0.63	0.58	0.53	0.23	0.21	0.19
	110 PSIG	1.25	1.15	1.05	1.00	0.92	0.84	0.96	0.63	0.57	0.25	0.23	0.21
	120 PSIG	1.36	1.25	1.14	1.09	1	0.91	0.74	0.68	0.62	0.27	0.25	0.23
	130 PSIG	1.46	1.34	1.22	1.17	1.07	0.97	0.80	0.73	0.66	0.29	0.27	0.25
	140 PSIG	1.57	1.44	1.31	1.25	1.15	1.05	0.85	0.78	0.71	0.32	0.29	0.26
	150 PSIG	1.67	1.53	1.39	1.33	1.22	1.11	0.90	0.83	0.76	0.33	0.30	0.27
200 PSIG	2.18	2.00	1.82	1.74	1.60	1.46	1.19	1.09	0.99	0.44	0.40	0.36	

To obtain flow capacities at conditions other than standard (SCFM @ 120 PSIG, 100°F Inlet & 100°F Ambient), locate the multiplier at the interception of actual operating conditions. Multiply the rated capacity of the selected dryer by the selected multiplier. The result is the corrected flow capacity. Flow rates greater than design due to capacity correction can result in increasing pressure drop.

Sullivan Palatek



Electric Driven Industrial Air Compressors

5-10 HP Belt Driven
15-40 HP Direct Drive
40-400 HP Updraft
High and Low Pressure
Variable Frequency Drive Designs
Specialty Packaged Systems

Piston Air Compressors
Splash Lube
Pressure Lube
Gas Driven

Compressed Air Accessories
Refrigerated Air Dryers
Desiccant Air Dryers
Air Filters
Condensate Management Systems
Oil Free Systems
Air System Analysis
System Management Solutions

Diesel Driven Portable Air Compressors

185 cfm to 1800 cfm
John Deere, Caterpillar and Cummins Engines
3 year Air End Warranty
Utility Models
Offshore Models

High Pressure Portable and Skid
950/350 to 1150/350

Instrument Quality Air
375H to 1600H
Skid Mount Aftercoolers
Skid Mount Dryers and Aftercoolers
Electric Construction Compressors
Electronic Parts Orders Through
SmartEquip™

Full Line of Pneumatic Tools
Hoses and Accessories

Sullivan-Palatek

1201 W US Hwy 20
Michigan City, IN 46360

PH: 800-438-6203

FX: 800-725-6203

info@palatek.com

www.sullivanpalatek.com

Distributed By:

