

# hadrian® STANDARD - Powder Coated Toilet Partitions - Headrail Braced

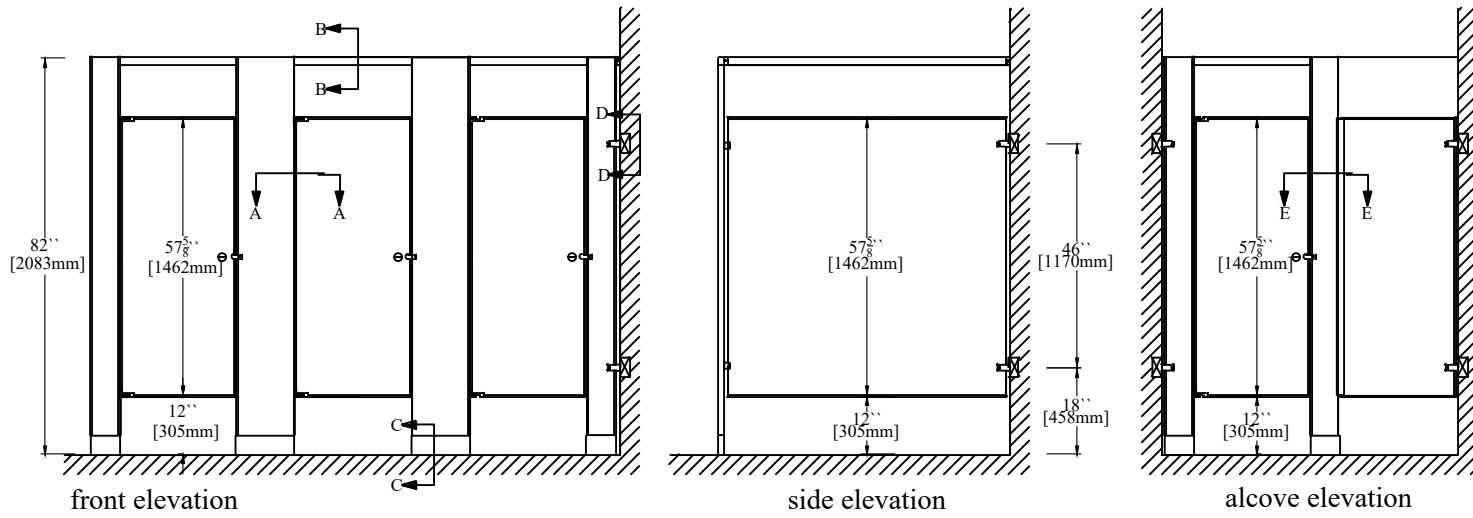

25mm (1") x 41mm (1.625")  
extruded anodized aluminum  
anti-grip headrail. Headrail sits  
3mm (.125") above pilaster.

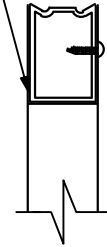

plan detail B-B

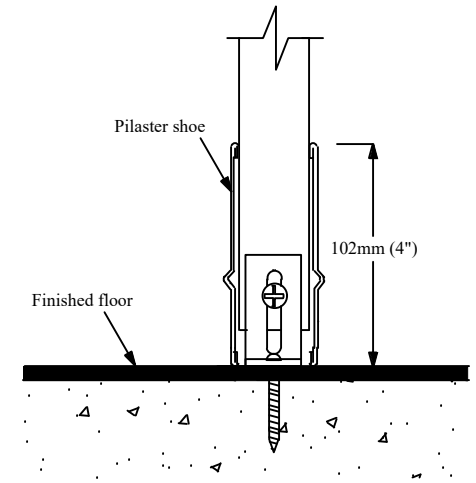

Concrete  
plan detail C-C

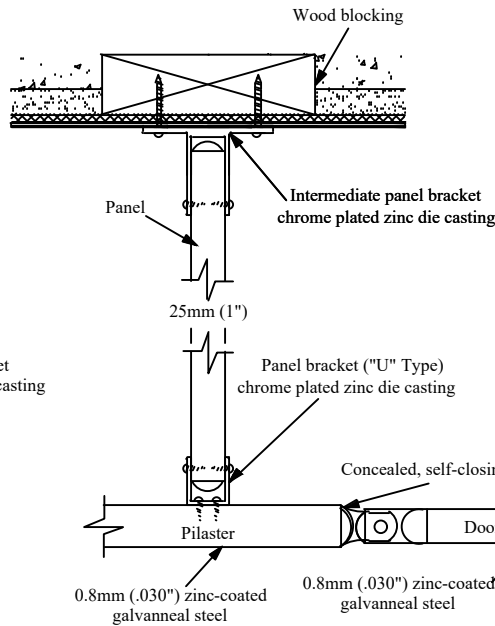

plan detail A-A

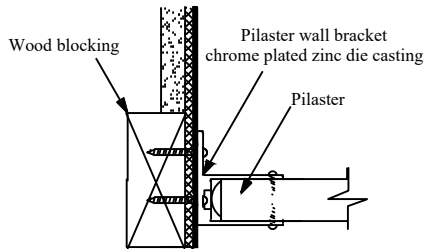

plan detail D-D

### Important Notes:

Refer to final drawings for wood blocking information. Wood blocking is critical to ensure a rigid installation.

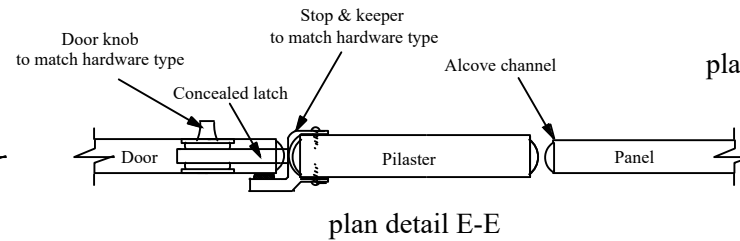

plan detail E-E

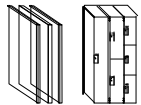

**Hadrian Manufacturing Inc.**  
**Hadrian Inc.,**  
[www.hadrian-inc.com](http://www.hadrian-inc.com)

965 Syscon Road, Burlington, ON, Canada, L7L 5S3  
7420 Clover Avenue, Mentor, OH, U.S.A., 44060  
3602 Washington St, Suite 200, Phoenix, AZ, U.S.A., 85009

Tel: (905) 333-0300    Fax (905) 333-1841  
Tel: (440) 942-9118    Fax (440) 942-9618  
Tel: (440) 942-9118    Fax (440) 942-9618