

L-Series Euro Damper Crank Trigger Kit Installation Manual

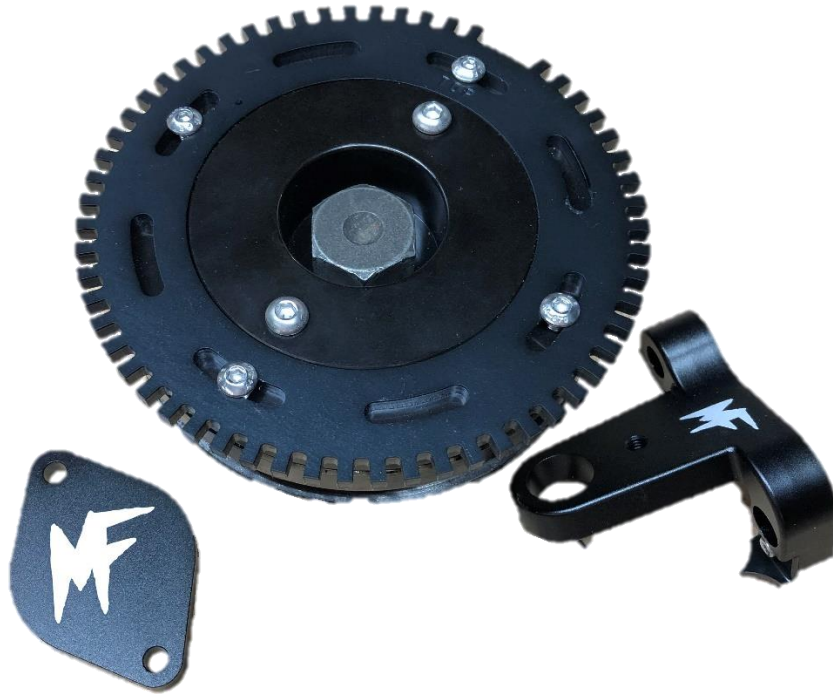

Index:

1. Disclaimer
2. Parts List
3. Installation Guide

Disclaimer

A vehicle modified with MilkFab Engineering products is intended for off road use only. It is the purchaser's responsibility to check and comply with all local, state, and federal laws prior to operating vehicle. Installation and use of performance products may also affect and void warranty. MilkFab Engineering shall not be liable for direct, indirect, incidental, or consequential damage to persons or property that might be claimed as a result from installation, improper installation, and failure of part including claims for delay, loss of profit, or labor.

Parts List

Parts Included

Quantity	Description
1	Damper "Top Hat"
1	Trigger Wheel
1	Crank Sensor Mount
1	Adjustable Timing Pointer
1	Distributor Block Off Plate
1	M6x1x18mm SS Hex Head Cap Screw
1	M8x1.25x85mm SS Hex Head Cap Screw
1	M3x0.5x10mm SS Hex Head Cap Screw
4	M5x0.8x10 SS Button Head Hex Screw
4	M5 SS Washer
2	M6x1x20 SS Button Head Hex Screw
3	M6x1x12mm SS Hex Head Cap Screw

Additional Parts Needed

Quantity	Description
1	Honeywell GT1 Hall Effect Sensor

Installation Guide

WARNING! Extreme caution should be taken when performing ANY maintenance or performance upgrades to your vehicle. Please observe and abide by any Warning or Caution labels placed on the various components and tools used when servicing your vehicle. If you have any questions regarding the installation or the various components included with the L-series crank trigger Kit, consult with a Professional Mechanic or contact MilkFab Engineering for more information.

Disassembly:

****BEFORE YOU BEGIN!****

Remove all contents from the MilkFab L-series Crank Trigger Kit and verify that ALL necessary hardware is present.

1. Raise the vehicle's hood.
2. Place engine at TDC by both referring to the crank pulley timing marks as well as the camshaft timing marks. Please refer to the FSM for more details about how to confirm the engine is at TDC.
3. Remove the Crank Damper Bolt and Washer. It may be necessary to remove the radiator and use an impact to remove.
4. Remove Crank Damper and install Euro/Professional Products Damper if not already on the car.
5. Once the engine is at TDC, the Crank Damper Bolt and Washer are removed, and the Euro/Professional Products Damper installed (if required) locate the Top Hat and the 2 - M6x1x20 SS Button Head Hex Screws. Using the fasteners, loosely thread the screws through the Top Hat and into the two threaded holes in the front of the damper. Do not tighten the bolts

completely as the Top Hat is made to center itself on the Crank Damper Bolt and not with the 2 M6 screws.

6. Locate the Crank Damper Bolt, clean the threads on the bolt and crankshaft thoroughly, apply medium strength thread locker, pass it through the Top Hat, thread into the crank and torque to 115 ft-lb. **(Note: always check that the Crank Bolt has enough thread engagement as well as isn't bottoming out before applying thread locker and torquing to spec).**
7. Remove, apply medium strength thread locker, and torque the 2 - M6x1x20 SS Button Head Hex Screws that attach the Top Hat to the Crank Shaft Damper to 40 in-lbs.

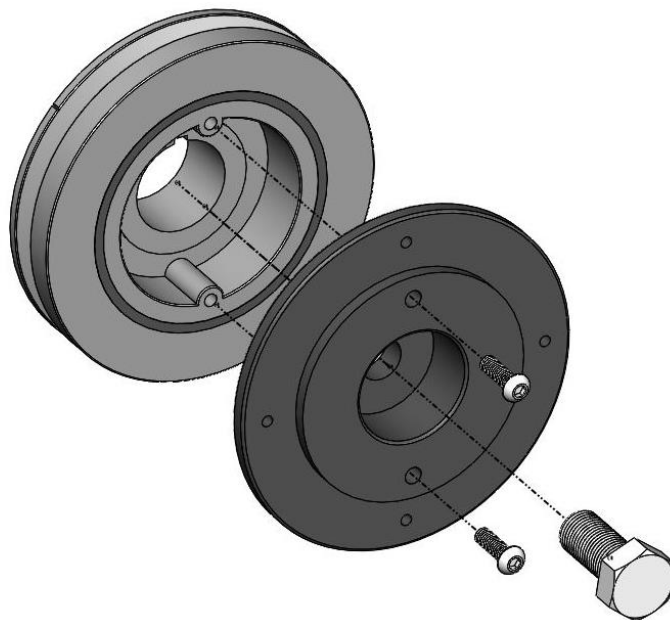

8. Attach the Crank Sensor Mount and Timing Pointer Assembly to the front cover by removing the M6 and M8 Bolts that hold on the original stamped timing indicator to the left (LHD: passenger side / RHD: drivers side) of the front cover. Locate the 1 - M8x1.25x85mm SS Hex Head Cap Screw and the 1 - M6x1x18mm SS Hex Head Cap Screw and loosely mount the Crank Sensor Mount and Timing Pointer Assembly to the front cover. Leave the two screws loose as the sensor gap will need to be adjusted before tightening.
9. Insert Hall Effect Sensor into the Sensor bracket, locate 1 - M6x1x12mm SS Hex Head Cap Screw, apply medium strength thread locker, and torque to 40 in-lbs.

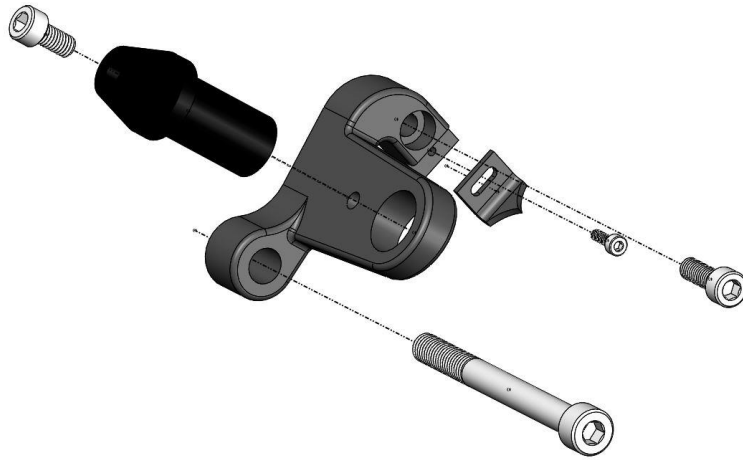

10. Install Trigger Wheel (36-1 or 60-2) onto the hub on the Top Hat with the engraved “TOP” on the Trigger Wheel pointing towards the front of the car and up towards the water pump.
11. Locate the 4 - M5x0.8x10 SS Button Head Hex Screws / 4 – M5 SS Washers and place them through the slots in the Trigger Wheel and into the Top Hat. Adjust the trigger wheel while the mounting screws are loose to align the center of the sensor to the center of the 6th tooth if using the 36-1 wheel and the center of the sensor to the center of the 11th tooth on 60-2 wheels. Snug the mounting screws after alignment to keep trigger wheel from moving while adjusting sensor gap.

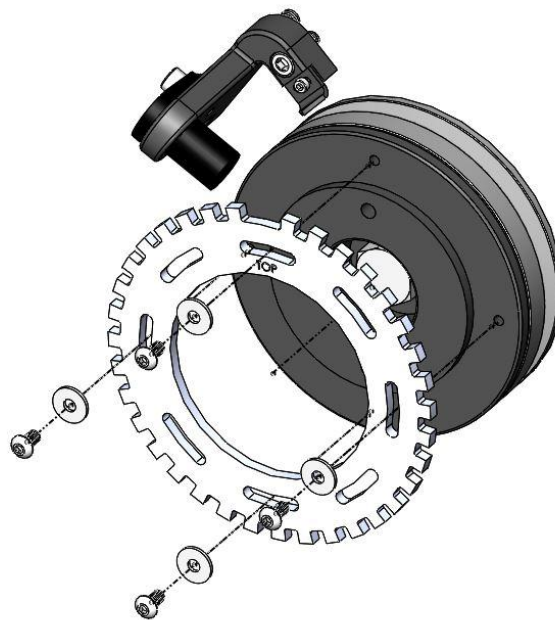

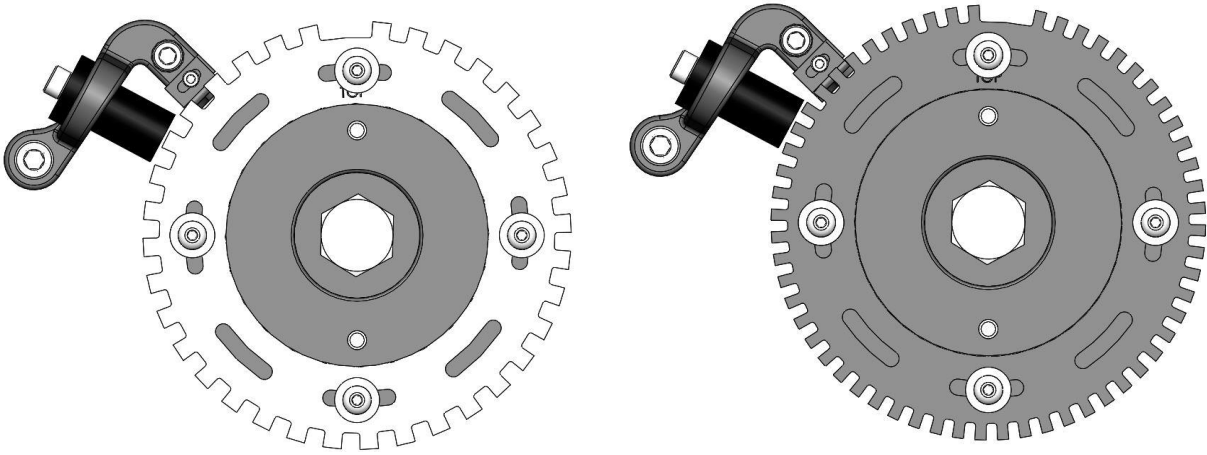

12. Adjust the Hall Effect Sensor gap to 1.0mm – 2.0mm using a feeler gage between the Hall Sensor and Trigger Wheel and by pivoting the Crank Sensor Mount about the M6x1x18mm SS Hex Head Cap Screw. Once Gap has been set torque the M6 Hex Head Cap Screw to 5 ft-lb and the M8 Hex Head Cap Screw to 10 ft-lbs.
13. Remove and apply medium strength thread locker to the M3 Hex Head Cap Screw holding the timing Pointer to the Crank Sensor Bracket, align the Timing Pointer to line up with the TDC marking on the Damper, and torque the M3 Hex to 8 in-lbs.
14. Remove the 4 - M5x0.8x10 SS Button Head Hex Screws that hold the Trigger Wheel to the Top Hat one by one, apply medium strength thread locker, and torque to 40 in-lbs.
15. Remove the distributor, apply new gasket, and attach the distributor block off plate using the 2 - M6x1x18mm SS Hex Head Cap Screws torqued to 6 ft-lbs.



16. Wire in the Hall Effect Sensor using the supplied pin out and the wiring specifications for your specific ignition system or EMS.
17. Enjoy stable Ignition Timing!