

Billi®



Superior Instant Filtered Water



BOILING



CHILLED



SPARKLING



STILL

Billi®

Originating in Australia, Billi has been at the forefront of the instant filtered boiling and chilled water systems industry for over 30 years. Billi products are celebrated for their combination of functionality, performance and contemporary aesthetics. Proudly Australian-made and designed, Billi products have brought a unique concept of underbench instant filtered boiling, chilled and sparkling drinking water to many countries around the globe.

Manufactured in Melbourne, Australia to strict quality standards, Billi water systems come with an assurance of quality, innovation and sustainability. Incorporating cutting edge eco-technology features and modern designs, Billi delivers solutions that keep pace with the ever-changing needs of its users.



CONTENTS

About Billi	p.03
Why Billi	p.04
Billi Service	p.05
How to choose your Billi	p.06
Product Features	p.08
IWBI Membership	p.10
Environmental Focus	p.12
Billi Technology	p.13
Premium Filtration	p.14
Billi Firewall Case Study	p.16
Product Range	p.18
Accessories	p.30
Testimonials	p.32
Billi 3D Build	p.33
On Wall & Sparkling Suits	p.34
Touchless Washroom Systems	p.36
Technical Drawings	p.38
Product Selection Guide	p.40
Warranty & Certifications	p.42

Synonymous with innovation, Billi prides itself on being the leading designer and manufacturer of boiling, chilled, sparkling and still filtered water systems.

With all Boiling & Chilled units manufactured in Melbourne, Australia, we are uncompromising on quality and dedicated to delivering the most reliable, high performance and stylish products on the market.

The Billi range of products include industry leading features such as water-cooled technology, space saving underbench footprints, specialty dispensers, plus a large range of models that do not require cupboard ventilation cut outs or grilles. This makes our units easy to install, energy efficient and user-friendly for all.



XT Dispenser in Matte Black finish with matching 70mm Riser & Font

CUSTOMER FOCUS

In every interaction with Billi, our commitment to the highest levels of customer service is evident.

Billi's unequalled aftersales care and product support, ensures that our valued relationship with our customers does not end at purchase.

Billi goes a step further with dedicated teams servicing each of our markets to ensure specialised care relevant to your requirements.

BilliCare offers our customers the very best in innovation, superior performance and reliability, and support this with a world class customer service experience.

Instant filtered drinking water systems require maintenance and filter replacements to ensure optimal water quality and an ongoing high level of performance. Our commitment is to make it easy for you.

Our Billi Customer Support team includes an Australia-wide network of trained service technicians and service agents to provide technically correct, prompt and reliable service.

For more information on our service plans, please visit our website www.billi.com.au/billicare-service-plans

Contact your local Billi team for more information on our range of service plans.



Service Plan Benefits*

- 💰 Reduce costs and downtime
- ✓ Manufacturer direct servicing ensures genuine filters & parts
- 🔧 Preventative maintenance ensures trouble-free operation for peace of mind
- 📋 Only accredited service technicians and agents will service your systems
- 📞 Work with a single service company nationally to simplify call bookings

Plumbing licenses: WA PL5415, QLD 1315239, NSW 291743C, SA PGE284004.

*Benefits will vary depending on plan chosen.

Select your preferred instant filtered water system by choosing the ideal combination to suit your requirements



Decide on the number of people that will be using the instant filtered water system

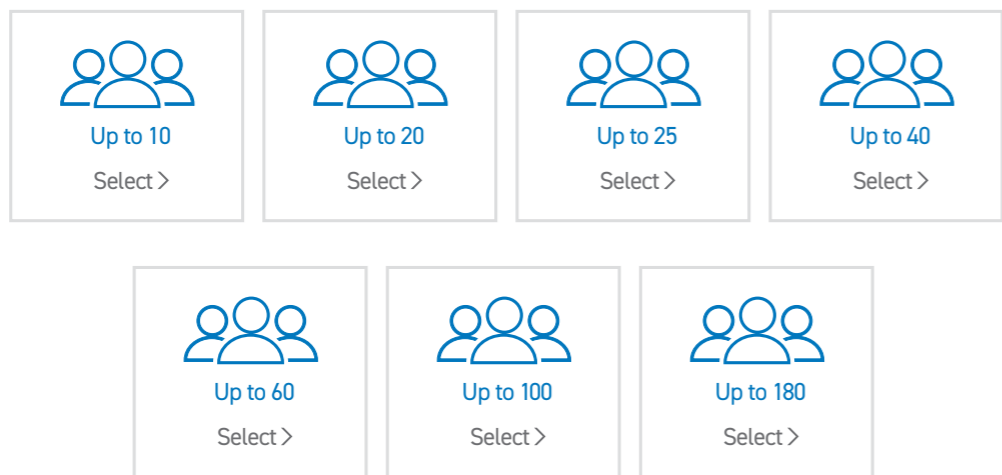

Select your preferred dispenser design from the compatible options



Optional Add Ons

Would you like a PLUS unit with separate sink mixer to provide hot & cold water?
Select your preferred mixer tap option



Need to install away from a sink? Use our range of fonts and risers to ensure the dispenser is optimally positioned

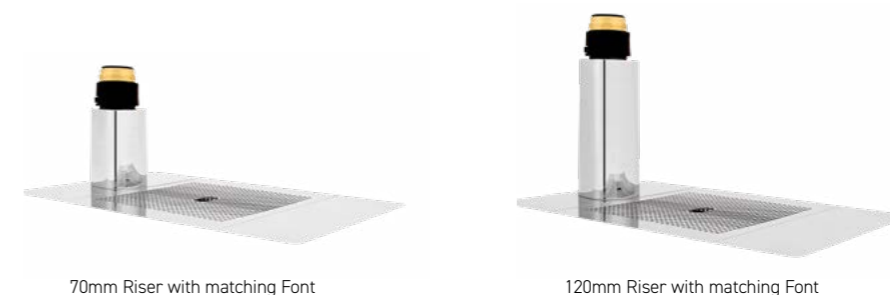

Select a specialty dispenser for additional safety in critical care environments



We're more than filtered water systems



On Wall Boiling Water



Billi Ultra On Wall Boiling Water Unit

**SPACE SAVING DESIGN**

With a focus on space saving, Billi systems have one of the smallest footprints on the market, allowing you to make the most of the valuable underbench space.

**SAFE TO OPERATE**

Billi's X series dispensers are supplied standard with a safety switch to lock off access to boiling water where needed. The red lock icon demonstrates when the safety switch is activated. Simply touch the sensor switch to release the lock and activate the boiling water. The dispenser will revert to safety mode after a period of non use.

**SPLASHFREE DELIVERY**

Billi's Splashfree boiling water delivery electronically varies the water flow, slowing momentarily to eliminate splashing as the water first enters the cup.

**ENERGY EFFICIENT**

Billi's unique Heat Exchange Technology enables our systems to achieve substantial energy savings. Our units also feature a standby mode which conserves energy by powering down after 2 hours of non-use.

**HEAT EXCHANGE TECHNOLOGY**

Billi's unique heat exchange & energy reclaim technologies recovers the waste heat energy produced in the chilling process to preheat the boiling water. This allows boiling water to reach optimal temperature more efficiently while achieving substantial energy savings.

**WATER-COOLED or AIR-COOLED TECHNOLOGY**

Billi are the only manufacturer to offer both water-cooled and air-cooled options. Our water-cooled systems utilise heat exchange & energy reclaim technologies and are more energy efficient than our air-cooled systems. Billi's heat exchange technology ensures water usage is minimal. Billi's air-cooled options generate far less heat than traditional air-cooled systems.

**NO CUPBOARD VENTILATION REQUIRED**

Billi's Water Cooled systems do not require cupboard ventilation or a cooling fan and operate a lot quieter than air cooled systems.

**ADJUSTABLE CHILLED TEMPERATURE**

A simple adjustable control knob allows the chilled water temperature to be raised to 15°C or lowered to 6°C for perfectly chilled, refreshing drinks. Your desired temperature is reached quickly and maintained efficiently during operation.

**ADJUSTABLE SPARKLING LEVEL**

Adjust the level of sparkling to suit your taste, with adjustable controls up to 5 bar of CO₂ pressure.

**ICE BANK TECHNOLOGY**

Our Ice bank technology has a chilled reservoir where both sparkling and chilled water supply passes through. In doing so, the dispensed water temperature is consistently chilled, also providing a higher level of carbonation.

**PLUS MODELS AVAILABLE**

Billi's PLUS models can function as your hot water service providing hot and cold water, as well as boiling, chilled, sparkling or still water. PLUS models also feature a boiling water reserve to ensure you will have a boiling water supply after the hot water supply is fully drawn. Ideal for areas without a hot water supply.

**UNLIMITED FILTERED WATER**

The Billi Alpine, Sahara, Quadra and Filter Tap ranges all offer a bottomless supply of still filtered water.*

**ECO-INTELLIGENCE TECHNOLOGY**

The Billi Eco & Sahara systems incorporate Eco-Intelligence technology which is a self learning timer allowing the unit to only operate when required. The self learning timer monitors daily usage patterns and even recognises evening and weekend changes in routine to effectively minimise energy consumption.

**CHOICE OF DISPENSER DESIGNS**

The Billi range offers a variety of dispenser options including our X series and slimline dispensers in a selection of modern finishes. Site specific tapware is available, including an XL Levered dispenser with red & blue coloured levers and braille pads for vision impaired applications.

**EASY INSTALLATION**

By eliminating the need for cupboard cut outs, our units are quick, easy and safer to install. Our units also feature a self commissioning function making setup simple and efficient.

**AUSTRALIAN DESIGNED & MADE**

All Billi boiling & chilled units are designed and manufactured in Australia.

**ACCESSORIES**

Billi has a range of stylish and functional accessories to match your needs including fonts, risers and tubing extension kits.



XL Levered Dispenser in Chrome finish with matching 70mm riser and font

Since 2019, Billi has been formally affiliated with the International Well Building Institute (IWBI) as a Cornerstone Member. Billi joins like-minded companies from across the globe that are committed to enhancing buildings and communities to help people thrive.

The membership program at IWBI convenes, celebrates and fosters collaboration with companies and organisations who are leading the movement to advance human health in buildings and communities around the world. This dynamic framework allows Billi to tap into IWBI's expansive resources and knowledge and demonstrates Billi's alignment with IWBI's mission.

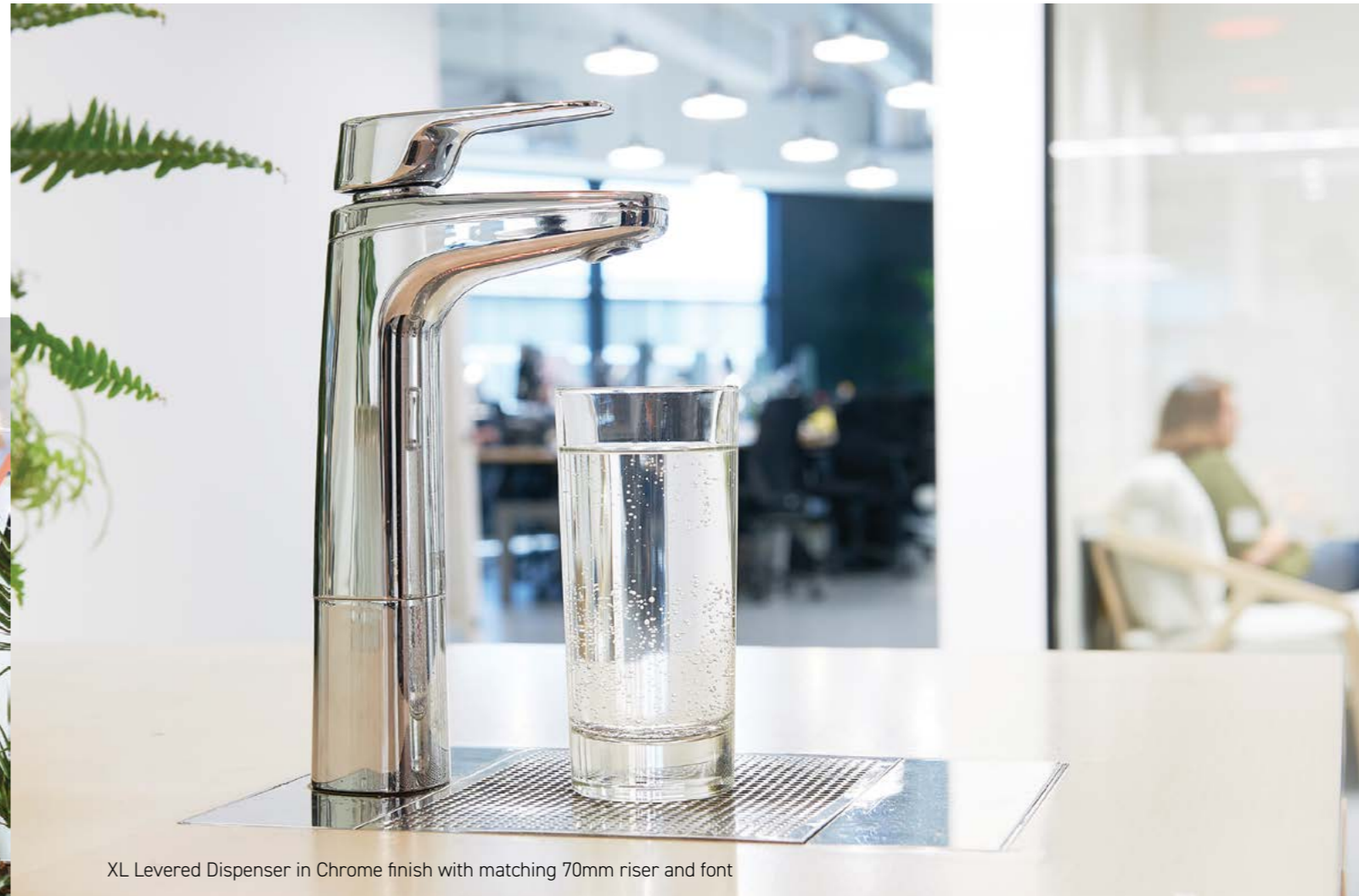

XL Levered Dispenser in Chrome finish with matching 70mm riser and font

"IWBI focuses on transforming health and wellbeing with our people-first approach to buildings, organisations and communities. As an IWBI Member, Billi has been an engaged contributor to the WELL movement since 2019 and we continue to enjoy a productive and collaborative relationship between our organisations within the region."

Jack Noonan, Vice President, International WELL Building Institute, Asia Pacific.

ABOUT IWBI

The International WELL Building Institute (IWBI) is leading the global movement to transform our buildings and communities in ways that help people thrive.

The WELL v2 pilot is the recently launched version of its popular WELL Building Standard, which will continue to be offered to the market, along with the WELL Community Standard pilot, a district scale rating system that sets a new global benchmark for healthy communities.

WELL is focused exclusively on the ways that buildings and communities, and everything in them, can improve our comfort, drive better choices, and generally enhance, not compromise, our health and wellness.

IWBI convenes and mobilizes the wellness community through management of the WELL AP credential, the pursuit of applicable research, the development of educational resources, and advocacy for policies that promote health and wellness everywhere.

For more information about IWBI and WELL, please visit: www.wellcertified.com

WELL HYDRATION PACK - INNOVATION OPPORTUNITY

The Ultimate Hydration Pack!

- ✓ Combine water intake recommendation with visual reminder
- ✓ Environmentally friendly glass bottle

Product Code: **882032**



Hydration Reminder Device

- Reminds you to stay hydrated throughout the day
- Easy to attach to your bottle
- Automatically turns on when you are working nearby
- Blinks when you forget to hydrate
- Office friendly – no audible alarms

Product Code: **882031**



Glass Water Bottle

- Large 1L capacity water bottle
- Durable borosilicate & BPA free
- Includes time indicators to achieve recommended water intake

Product Code: **882019**



Billi's Environmental Sustainability



Billi is renowned for its eco focus, ensuring our drinking water appliances go beyond water and energy saving. We aim for low environmental impact to enhance the enjoyment of your personal surroundings.

A total quality commitment makes a Billi system Australia's first choice in water appliances – stylish designs combined with impressive performance.

Chilling water creates waste heat energy. Billi's patented technology recovers and reuses energy to preheat the boiling water, thereby saving energy.

Effective water and energy saving initiatives help meet Green Building Design (GBD) objectives. Billi filtered water systems offer unique power consumption advantages:

- Thermodynamic heat-exchange technology recovers and reuses heat energy;
- High performance polyethylene insulation retains water temperature and saves energy.
- Stand-by mode conserves power during set non-use periods.

Billi lets you enjoy pure, clean water without costly environmental impact through achieving optimal water and energy savings.

GreenTag Certification

Global GreenTag is one of the world's most robust, trusted and widely recognised ecolabels which independently assures that every product is fitness tested and certified under leading certification programs that use world's best scientific methods.

They have earned the reputation and trust of thousands of buyers, hundreds of companies and numerous green building councils, certification bodies and governments around the world.

Billi complies with GreenTag International standard v.32 with Gold level certification on the Eco, Quadra and Quadra Plus models.



The assessments required to achieve the Gold level certification includes:

- ✔ Australian Made
- ✔ Building/Product Synergy
 - Makes building & other systems more efficient
 - Multiple purpose product
- ✔ Corporate Social Responsibility
 - Building code of Australia compliant
 - Complies with Australian law
 - Fit for purpose certified
- ✔ Health & Ecotoxicity
 - Considered safe to use
- ✔ LCA
 - Life Cycle Analysis – Greenhouse Gas
 - 'Low carbon'
 - Carbon footprint available
- ✔ Life Cycle Analysis – Water
 - Highly water efficient

Heat Exchange Technology

Billi's unique heat-exchange technology recovers the waste heat energy produced in the chilling process to preheat the boiling water. This allows the boiling water to reach optimal temperature more efficiently while achieving substantial energy savings.

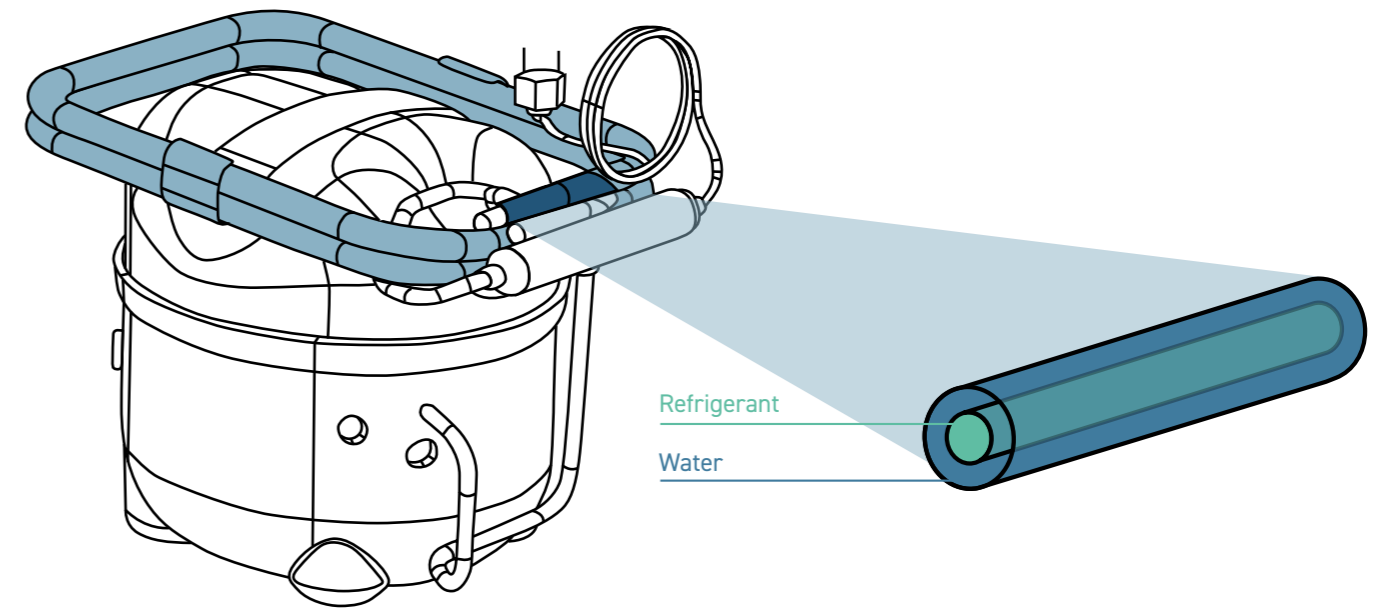

Billi compressor component shown, highlighting unique reclaim technology.

Water-Cooled vs Air-Cooled

Billi is the only manufacturer to offer both water-cooled and air-cooled technology. Our water-cooled systems are a more energy efficient option and Billi's heat exchange technology ensures minimal water usage.

WATER-COOLED TECHNOLOGY		AIR-COOLED TECHNOLOGY
<ul style="list-style-type: none"> • Billi water-cooled units do not require cupboard ventilation or a cooling fan. • No cupboard cut-outs or grilles. • Energy usage is reduced significantly as heat generated during the chilling process is used to preheat the boiling water. 		<ul style="list-style-type: none"> • Billi air-cooled units generate less heat than traditional air-cooled systems. • No water required for the chilling process. • Cupboard ventilation recommended.



Billi®

ADVANCED
MULTI-STAGE
FILTRATION
TECHNOLOGY

Billi prides itself on offering world class water filtration products and continues to partner with global leading experts in all areas of water filtration.

- Activated carbon fibre
- High level chlorine & chemical adsorption
- Turbidity reduction
- Chemical taste & odour reduction
- Graded density structure to remove cysts with low pressure drop (994052 only)

Billi & BWT

Billi has partnered with BWT to provide the highest quality filters. BWT is Europe's largest water treatment products company.

Billi's range of premium filters utilise BWT's unique Fibron X technology. Fibron X technology has a graded density profile ensuring maximum performance and capacity. Billi's filter range provides superior water quality, consistent filter life and peace of mind.

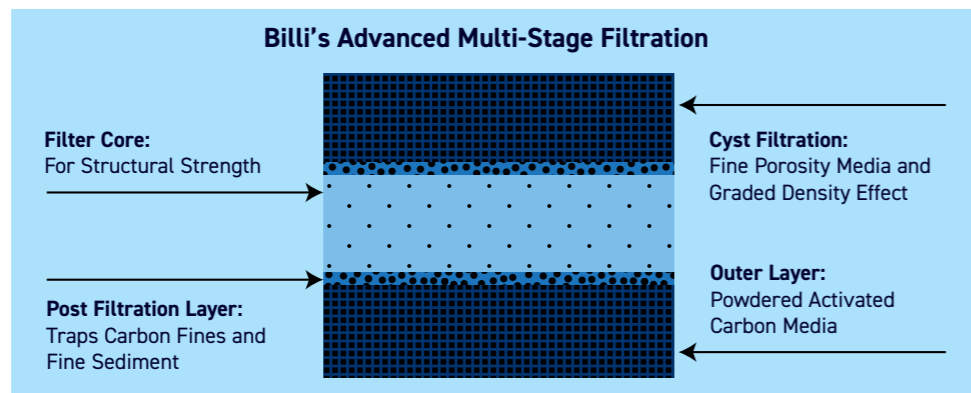

Billi Premium Filtration vs Standard Filtration

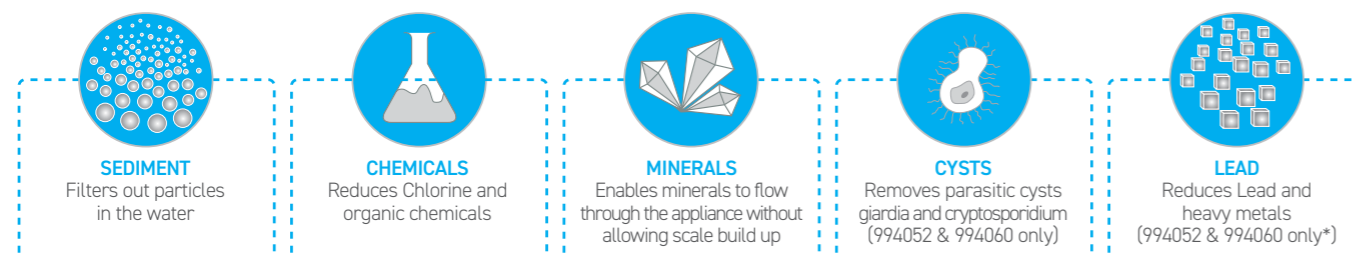
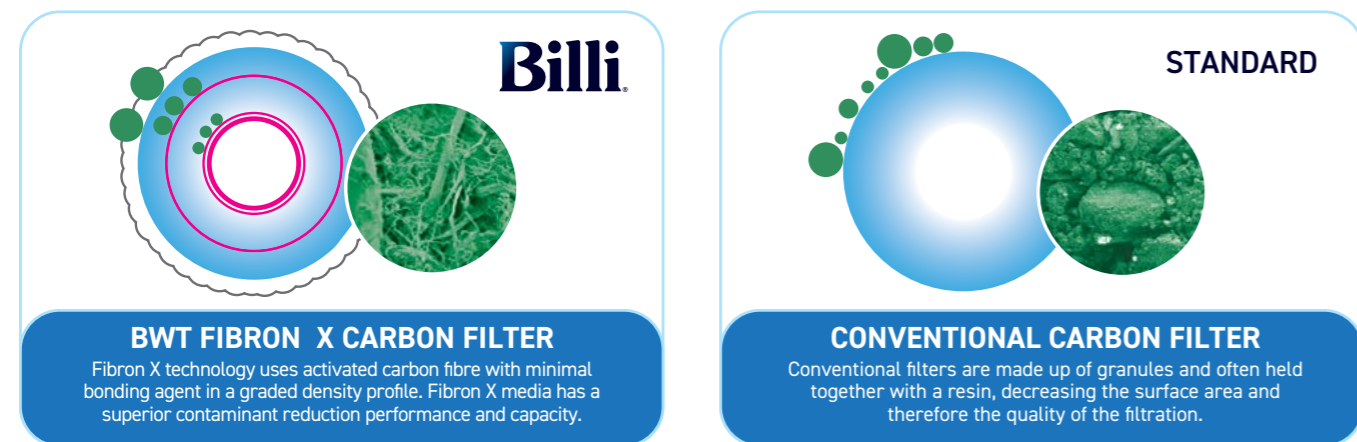

Billi filters have been independently tested and certified by IAPMO to international standards and Australian Watermark. Billi filter performance testing is conducted in accordance with international standards NSF, WRAS and Watermark.

*Lead Reduction on 994052 + 994060 @ 98.93%

Replacement Filters

Periodic replacement of filters is necessary to maintain water quality. Genuine replacement Billi filters are available on our website and from your local approved supplier. Filters are also available to suit the needs of different water supply areas.

Billi recommends you change your filter at least every 12 months. Replacing your filter cartridge is simple. Solid amber dispenser icons indicate when replacement is due. The swing change filter simply swings forward and slides out. Fitting the new filter is just as easy – simply slide the filter in and swing it back. The cartridge locks into place.

All Billi genuine filters come with a digital lockout feature to ensure single use and hygiene.

For further installation instructions refer to your user guide or visit www.billi.com.au/billi-how-to-videos

Easy filter change. Simply swing forward and slide out to replace filter.



5 Micron Fibron X® Replacement Filter 994051

Nominal Filter Rating | 5 Micron
Filtration Capability | Sediment, Chlorine, Taste & Odour
Flow Rate | 3.8lpm
Water Pressure | 80 kPa min - 860 kPa max
Capacity | 30,000 litres (Chlorine reduction)
Water Temperature | 38°C max; Must not freeze

0.2 Micron Fibron XC® Replacement Filter 994052

Nominal Filter Rating | 0.2 Micron
Filtration Capability | Sediment, Chlorine, Taste & Odour
Parasitic Cysts, Lead
Flow Rate | 3.8lpm
Water Pressure | 80 kPa min - 860 kPa max
Capacity | 30,000 litres (Chlorine reduction)
Water Temperature | 38°C max; Must not freeze

HSD Fibron XT® Replacement Filter 994054

Filtration Capability | Sediment, Chlorine, Taste & Odour
Flow Rate | 3.8lpm
Water Pressure | 80 kPa min - 860 kPa max
Capacity | 30,000 litres (Chlorine reduction)
Water Temperature | 38°C max; Must not freeze

Sediment Only Replacement Filter 994056

Filtration Capability | Sediment
Flow Rate | 3.8lpm
Water Pressure | 80 kPa min - 860 kPa max
Capacity | 30,000 litres
Water Temperature | 38°C max; Must not freeze

0.2 Micron HF Sediment Only Replacement Filter 994060

Filtration Capability | 0.2 Micron HF Sediment
Flow Rate | 3.8lpm
Water Pressure | 80 kPa min - 860 kPa max
Capacity | 10,000 litres
Water Temperature | 38°C max; Must not freeze

Firewall® Tower Dispenser



THE TECHNOLOGY

In January 2020, over a 20-day period, leading independent laboratory ALS Environmental tested 3 x Billi underbench systems equipped with Firewall Tower dispensers to measure their effectiveness at eliminating legionella from drinking water. This type of testing is critical to ensure customer peace of mind, especially in Australia where Legionella is commonly found in the water supply.

The technology is sourced from the Waterlogic Firewall X system, which used bespoke UVC bulbs and Electronic ballasts to completely inactivate bacteria, viruses and pathogens including E.Coli, Salmonella and Hepatitis all the way through to the dispensing nozzle. This internationally patented technology has already been proven up to 99.99% effective in over 5,000 independent tests. It is the only UVC system in the world today that is certified to NSF protocols 55a and P231, classifying it as a "Microbiological Purification Device."

"Our specialist health care centre in Brisbane was supplied with Billi's new Firewall Tower dispenser on an in situ trial agreement, at the start of 2020. The Firewall Tower dispenser was installed in conjunction with a new water cooled Quadra underbench system, and so far we have been very happy with the product performance. We have received prompt & friendly support with no issues being experienced to date. We are pleased to have no breakdowns and a safe supply of cold, filtered drinking water for our team of health care workers."

S.M. - National Facilities Manager
Health Care Service Provider Brisbane, June 2020

ALS Environmental are an independent global leader in testing, certification, inspection and verification for life sciences, commodities and industrial sectors. They operate laboratories specialising in environmental monitoring, food and pharmaceutical, electronics and consumer products markets.



TESTING PROVED CONCLUSIVE

ALS carried out tests on a daily and weekly basis, taking samples of both cold and ambient water, and spiking the incoming water with extremely high levels of the Legionella serogroup 1 organism. Each underbench unit was linked to a dosing tank system and was also tested with a 5 micron carbon block filter in place.

Two samples of water from each dispenser were tested, one in the morning and one in the evening, in their purest form (without flushing). The average count of Legionella in the untreated dosing tank was 25 million CFU (Colony Forming Unit) per 100ml of water. After testing water that had passed through Billi's Firewall Tower dispenser, the outcome was noted as < 1 CFU/100ml, effectively recognised as a count of zero.

FIREWALL® UVC SPIRAL

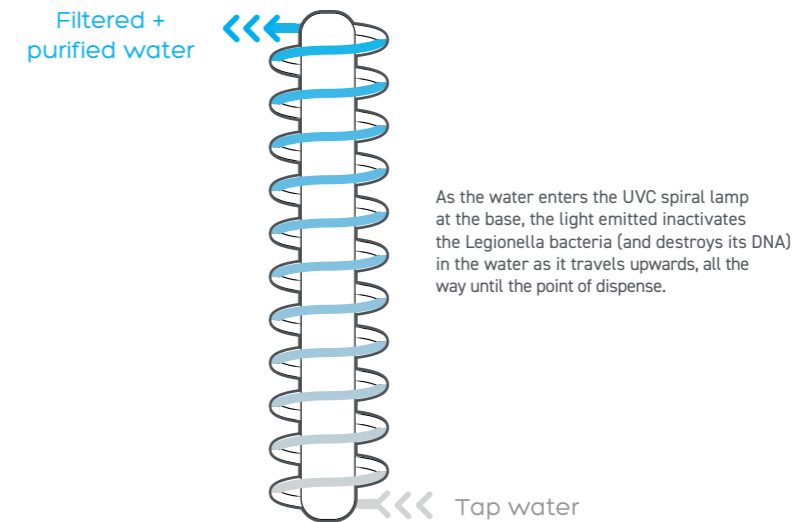

Underbench model details are as below;

- Unit 1 (U1), was an air cooled model that was tested with an average dose of 303,000 CFU/100ml.
- Unit 2 (U2), was a Quadra Compact, water cooled model that was tested with an average dose of 1.24million CFU/100ml.
- Unit 3 (U3), was a second Quadra Compact, water cooled model that was tested with an average dose of 2.24 million CFU/100ml.

After a 20-day period of testing, the results verified that the Firewall Tower dispenser conclusively displayed < CFU/100ml of any microbiological contamination, including legionella serogroup 1.



Disclaimer:
Samples collected by ALS according to procedure EN/67. Results are approximate and for indicative purposes only. Legionella species refers to Legionella species other than Legionella pneumophila.



XL Levered Dispenser in Matte Black finish



Billi Eco

Instant boiling and chilled filtered water system

FEATURES



DISPENSER OPTIONS



Product Code	Model	Suggested no. of people	Boiling water delivery (cups per hour)*	Chilled water delivery (cups per hour)	Power supply (amps)
901000	Eco	up to 10	90	60	10

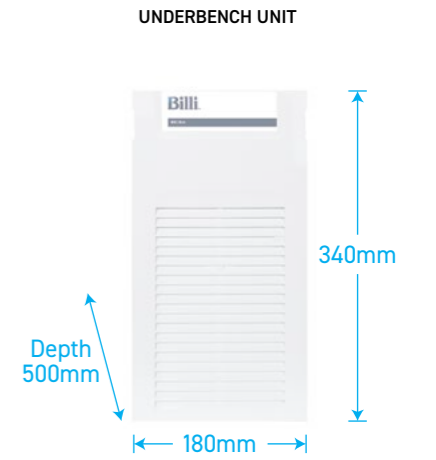

Billi Eco Sparkling

Instant boiling, chilled and sparkling filtered water system

FEATURES



DISPENSER OPTIONS



Product Code	Model	Suggested no. of people	Boiling water delivery (cups per hour)*	Chilled and Sparkling (cups per hour)	Power supply (amps)
906000	Eco Sparkling	Up to 10	90	100	2 x 10

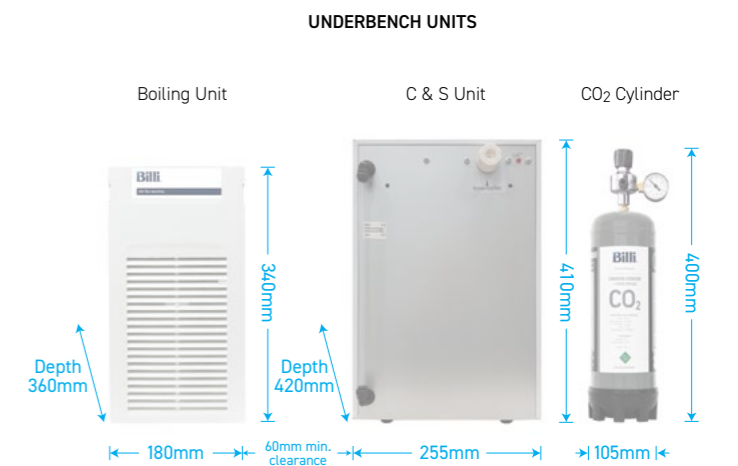

* Based on the initial number of cups of boiling water immediately available, drawn one cup every 10 seconds. For all underbench filtered water systems, consideration may be needed for usage patterns and draw-off methods. 1 cup = 170ml



Billi Quadra

Instant boiling and chilled filtered water system

FEATURES



DISPENSER OPTIONS



Product Code	Model	Suggested no. of people	Boiling water delivery (cups per hour)*	Chilled water delivery (cups per hour)	Power supply (amps)
904010	Quadra Compact	up to 20	100	150	10
904020	Quadra 420	up to 25	120	175	10
904040	Quadra 440	up to 40	150	175	10
904060	Quadra 460	up to 60	180	175	10
904100	Quadra 4100	up to 100	250	175	15
904180	Quadra 4180	up to 180	350	175	20

^ XT not available with Quadra Compact and Quadra 460.

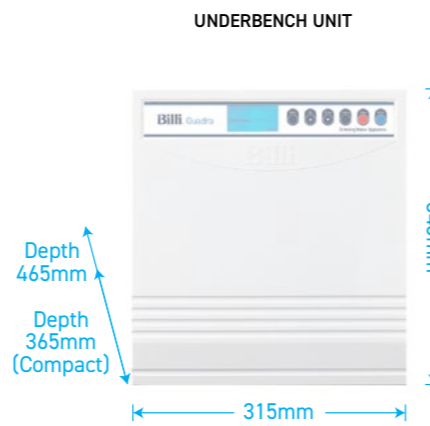

Billi Quadra Plus

Instant boiling and chilled filtered water system plus hot and cold mixer tap. Twin Plus models include 2 separate mixer taps.

FEATURES



DISPENSER OPTIONS + MIXER TAP OPTIONS



Product Code	Model	50° hot water capacity litres (initial drawdown)	50° hot water delivery litres per hour	Boiling water delivery (cups per hour)*	Chilled water delivery (cups per hour)	Power supply (amps)
904025	Quadra Plus 5	7	40	120	175	10
904065	Quadra Plus 9	9	60	180	175	10
904105	Quadra Plus 15	15	85	250	175	15
904107	Quadra Twin Plus 15	15	85	250	175	15
904187	Quadra Twin Plus 21	21	100	350	175	20

* Based on the initial number of cups of boiling water immediately available, drawn one cup every 10 seconds. For all underbench filtered water systems, consideration may be needed for usage patterns and draw-off methods. 1 cup = 170ml.



Billi Quadra Sparkling

Instant boiling, chilled and sparkling filtered water system.

FEATURES



DISPENSER OPTIONS



Product Code	Model	Suggested no. of people	Boiling water delivery (cups per hour)*	Chilled & Sparkling water delivery (cups per hour)	Power supply (amps)
906060	Quadra Sparkling 460	60	180	200	2 x 10
906100	Quadra Sparkling 4100	100	250	200	1 x 10 1 x 15

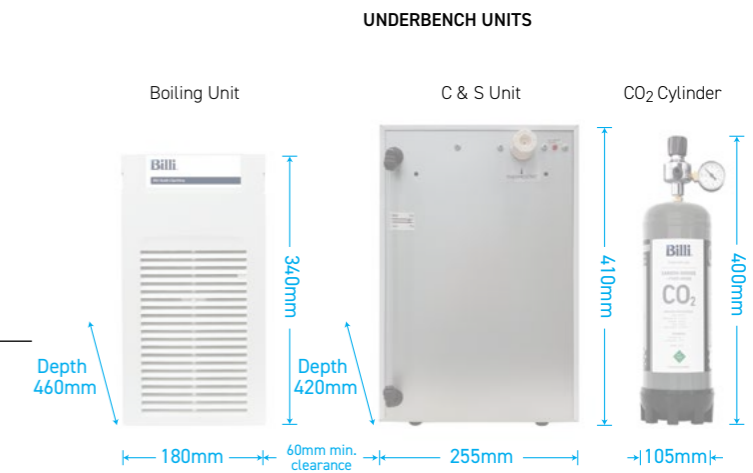

Billi Quadra Sparkling Plus

Instant boiling, chilled and sparkling filtered water system plus separate hot and cold mixer tap.

FEATURES



DISPENSER OPTIONS + MIXER TAP OPTIONS



Product Code	Model	50° hot water capacity litres (initial drawdown)	50° hot water delivery litres per hour	Boiling water delivery (cups per hour)*	Chilled & Sparkling water delivery (cups per hour)	Power supply (amps)
906065	Quadra Sparkling Plus 9	9	60	180	200	2 x 10
906105	Quadra Sparkling Plus 15	15	85	250	200	1 x 10 1 x 15

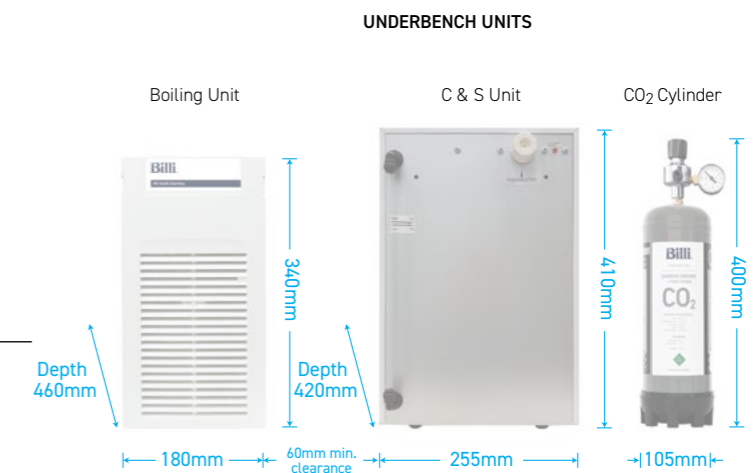



Billi Sahara

Instant boiling and still filtered water systems

FEATURES



DISPENSER OPTIONS



Product Code	Model	Suggested no. of people	Boiling water delivery (cups per hour)*	Still water delivery (cups per hour)	Power supply (amps)
943010	Sahara 310	up to 10	90	unlimited	10
943020	Sahara 320	up to 25	120	unlimited	10
943060	Sahara 360	up to 60	180	unlimited	10
943120	Sahara 3120	up to 120	250	unlimited	15



Billi Sahara Plus

Instant boiling and still filtered water system plus separate hot and cold mixer tap.

FEATURES



DISPENSER OPTIONS

MIXER TAP OPTIONS



Product Code	Model	50° hot water capacity litres	50° hot water delivery litres per hour	Boiling water delivery (cups per hour)*	Still water delivery (cups per hour)	Power supply (amps)
943025	Sahara Plus 320	7	25	120	unlimited	10
943065	Sahara Plus 360	9	40	180	unlimited	10
943125	Sahara Plus 3120	15	65	250	unlimited	15

A reserve of boiling water is still available after hot water is fully drawn.

* Based on the initial number of cups of boiling water immediately available, drawn one cup every 10 seconds. For all underbench filtered water systems, consideration may be needed for usage patterns and draw-off methods. 1 cup = 170ml



Billi Alpine

Chilled and still filtered water systems

FEATURES



DISPENSER OPTIONS



Product Code	Model	Product feature	Suggested no. of people	Chilled delivery (cups per hour)	Power supply (amps)
932060	Alpine 060	Chilled	12	60	10
932120	Alpine 120	Chilled	25	120	10
932125	Alpine 125	Chilled & Still	40	120	10



Billi Alpine Sparkling

Professional grade chilled & sparkling system

FEATURES



DISPENSER OPTIONS



Product Code	Model	Suggested no. of people	Chilled & Sparkling delivery (cups per hour)	Power supply (amps)
933100	Alpine Sparkling 100	40	100	10
933200	Alpine Sparkling 200	80	200	10

For additional high capacity sparkling options, see page 34.

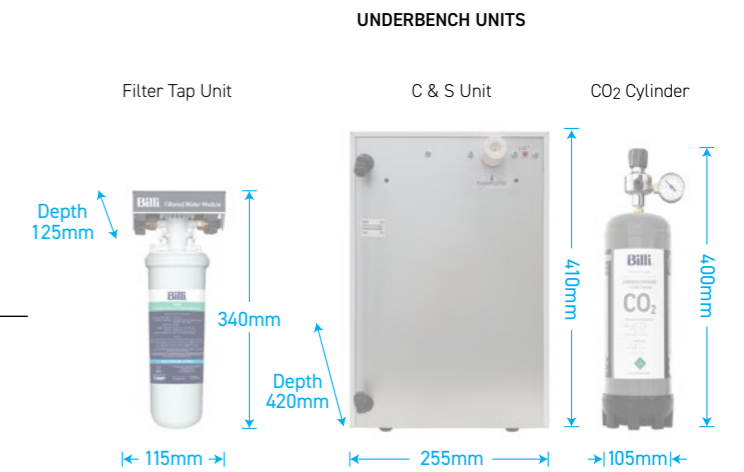
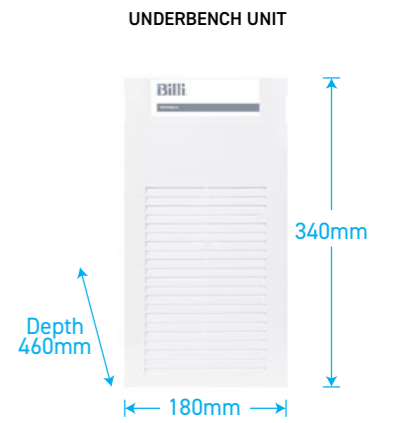
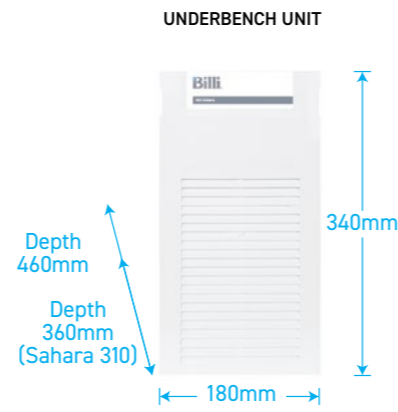



Billi Filter Tap

Instant still filtered water system

FEATURES



NO CUPBOARD
VENTILATION
REQUIRED



SPACE SAVING
DESIGN

DISPENSER OPTIONS



Product Code	Model	Still water cups per hour
932210	Filter Tap	unlimited



p.25

X SERIES DISPENSERS



XL Levered Dispenser (XL)

The levered dispenser is streamlined and elegant. It is simply operated with position-sensitive levers.

Add 'L' and finish code to product code (901000LCH)

FINISH OPTIONS

CH	BR	MB	MW
Chrome	Brushed	Matte Black	Matte White

SPECIAL ORDER FINISHES

RG	PL	BRG	UB	GM
Rose Gold	Platinum	Brushed Rose Gold	Urban Brass	Gun Metal Grey

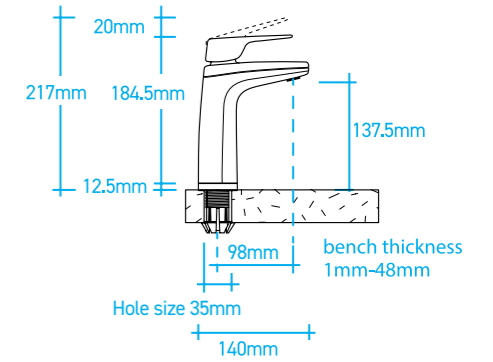

XT Touch Dispenser (XT)

The touch dispenser is an innovative, contemporary design, which has a top operating panel offering a sophisticated and clean style.

Add 'T' and finish code to product code (901000TCH)

FINISH OPTIONS

CH	BR	MB	MW
Chrome	Brushed	Matte Black	Matte White

SPECIAL ORDER FINISHES

RG
Rose Gold

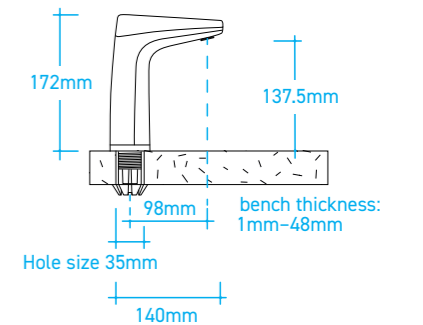

XR Remote Dispenser (XR)

The remote dispenser is another version of the lever free dispenser, however the operation panel is located away from the dispenser. This can be installed in your desired position to meet design requirements, particularly wheelchair access.

Add 'R' and finish code to product code (901000RCH)

FINISH OPTION

CH
Chrome

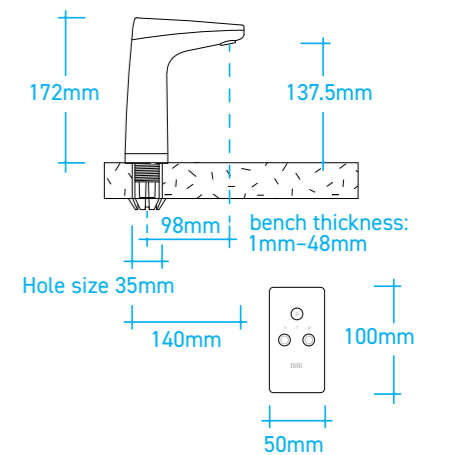

XT Dispenser in Matte Black finish with matching 70mm Riser and Font



Safety Dispenser (SD)

Safety Dispenser has been specifically designed as a solution for critical care applications, such as correctional centres, mental health facilities and aged care.

Add 'V' and finish code to product code (901000VCH)

FINISH OPTION

CH
Chrome

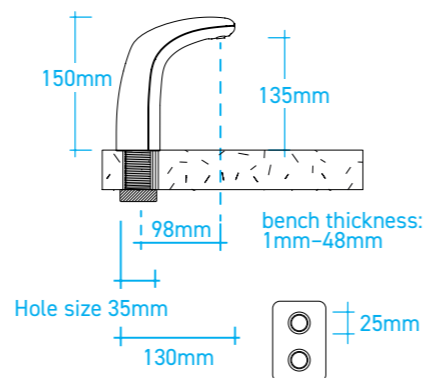

Coloured XL Levered Dispenser

Special order coloured levers provide full vision safety where LED indicators cannot be seen.

Product Code: 996300

BRILLE PADS

Optional braille pads can be supplied with the coloured XL levered dispenser to provide further safety for vision impaired users.

FINISH OPTION

RB
Chrome with Red & Blue Levers



* Product LEDs are for image purposes only. Fully functional product operates in accordance to specification.

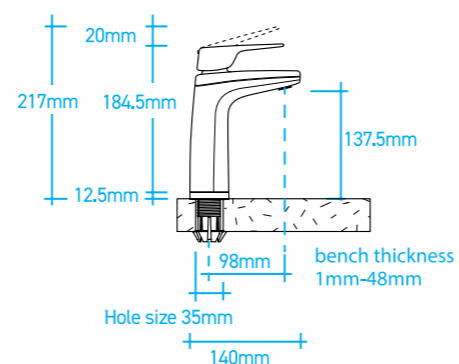

Billi Firewall® Tower Dispenser (FT)

Combines the latest in UVC water purification technology with the convenience of instant boiling and chilled water. Compatible with Billi's existing Quadra range, the Firewall® Tower Dispenser utilises Firewall® and BioCote® antimicrobial technologies, making it ideal for the Health and Aged Care Sectors.

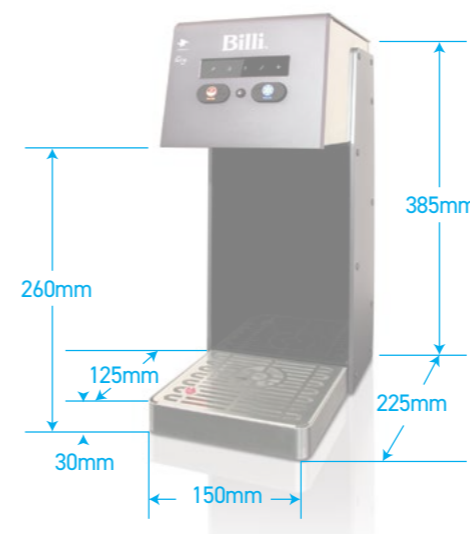

FEATURES

FIREWALL®
GUARANTEED PROTECTION!

BioCote®
MAKES HIGH CONTACT SURFACES MORE HYGIENIC

• UVC Light eliminates 99.99% of impurities.

UNDERBENCH UNIT OPTIONS

Quadra Compact, Quadra 420/440/460/4100/4180



Ideal for Health & Aged Care Sectors

See Firewall Tower Case Study on page 16.

* Dispenser can be retrofit to Quadra models. For full installation requirements or to learn more, contact your Billi representative.

SLIMLINE DISPENSERS



Dual Lever Dispenser **(D)**

Round in design with dual levers.
Suitable for chilled and sparkling water.

Add 'D' and finish code to product code (933100DCH)

FINISH OPTIONS

CH	BR	MB
Chrome	Brushed	Matte Black

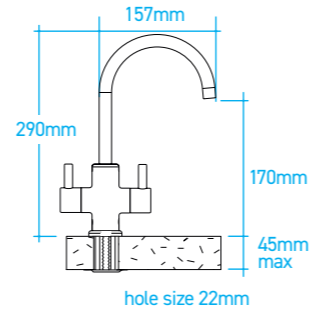

Round Slimline Dispenser **(R)**

Round in design with single pin lever option.
Suitable for ambient or chilled water.

Add 'R' and finish code to product code (932060RCH)

FINISH OPTIONS

CH	BR	MB	MW
Chrome	Brushed	Matte Black	Matte White

SPECIAL ORDER FINISHES

RG	PL	BRG	UB	GM
Rose Gold	Platinum	Brushed Rose Gold	Urban Brass	Gun Metal Grey

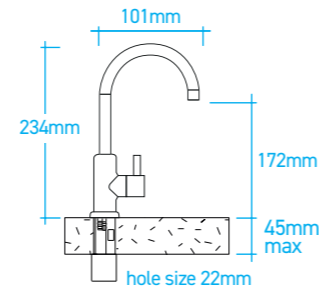

Square Slimline Dispenser **(S)**

Square in design with single paddle lever option.
Suitable for ambient or chilled water.

Add 'S' and finish code to product code (932060SCH)

FINISH OPTIONS

CH	BR	MB	MW
Chrome	Brushed	Matte Black	Matte White

SPECIAL ORDER FINISHES

RG	PL	BRG	UB	GM
Rose Gold	Platinum	Brushed Rose Gold	Urban Brass	Gun Metal Grey

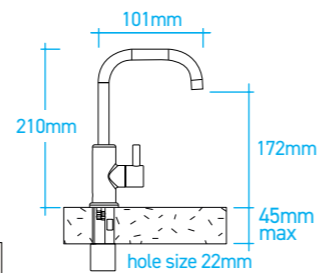

Slimline Dispenser Accessory



Square Slimline Spout Extension **(E)**

Extended spout allows bottles and jugs to be filled when the tap is installed on a front.

Product Code: 992130CH / 992130BR / 992130MB

FINISH OPTIONS

CH	BR	MB
Chrome	Brushed	Matte Black

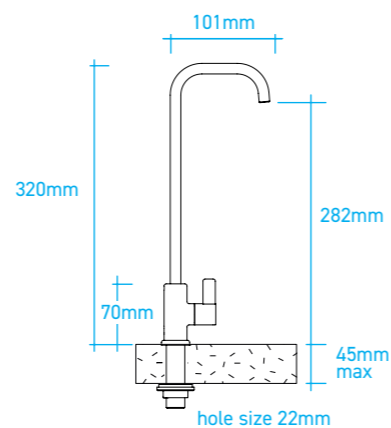

MIXER TAPWARE



Gooseneck Mixer Tap **(G)**

Round gooseneck design suitable for plus units and offers hot and cold water in addition to X Series dispenser range. Also available as a stand-alone mixer tap.

Add 'G' and finish code to product code and dispenser option (904025LGCH)

FINISH OPTIONS

CH	BR	MB	MW
Chrome	Brushed	Matte Black	Matte White

SPECIAL ORDER FINISHES

RG	PL	BRG	UB	GM
Rose Gold	Platinum	Brushed Rose Gold	Urban Brass	Gun Metal Grey

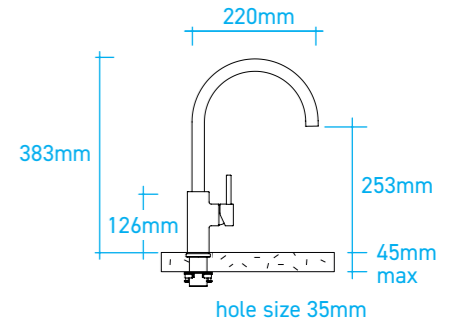

Square Mixer Tap **(S)**

Square gooseneck design suitable for plus units and offers hot and cold water in addition to X Series dispenser range. Also available as a stand-alone mixer tap.

Add 'S' and finish code to product code and dispenser option (904025LSCH)

FINISH OPTIONS

CH	BR	MB	MW
Chrome	Brushed	Matte Black	Matte White

SPECIAL ORDER FINISHES

RG	PL	BRG	UB	GM
Rose Gold	Platinum	Brushed Rose Gold	Urban Brass	Gun Metal Grey

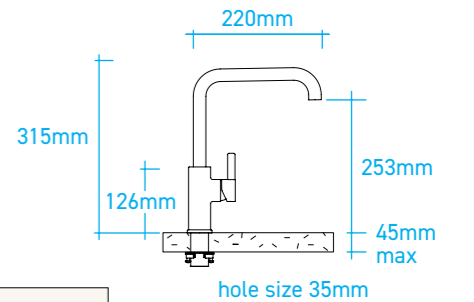

Paddle Lever Mixer Tap **(P)**

Standard mixer tap supplied with Plus units and offers hot and cold water in addition to X Series dispenser range. Also available as a stand-alone mixer tap.

Add 'P' and finish code to product code and dispenser option (904025LPCH)

FINISH OPTIONS

CH	BR	MB	MW
Chrome	Brushed	Matte Black	Matte White

SPECIAL ORDER FINISHES

RG	PL	BRG	UB	GM
Rose Gold	Platinum	Brushed Rose Gold	Urban Brass	Gun Metal Grey

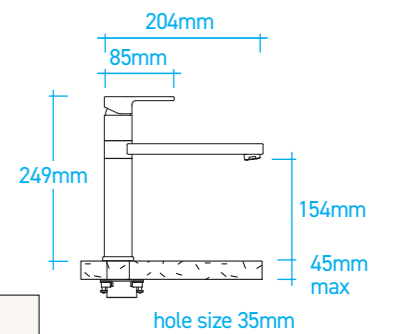

Mixer Tap Accessory



Disabled Lever - **(D)** For use with Paddle Lever Mixer Tap

Suitable for plus units and offers hot and cold water in addition to X Series dispenser range.

Product Code : 992111CH / 992111MB

FINISH OPTIONS

CH	MB
Chrome	Matte Black

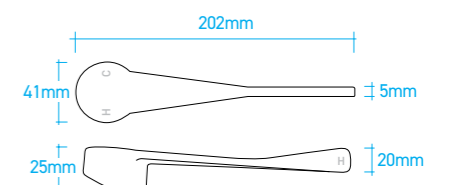

ACCESSORIES

Font with 70mm Riser

Suitable for: **XL** **XT** **XR**

Product Code: 992800

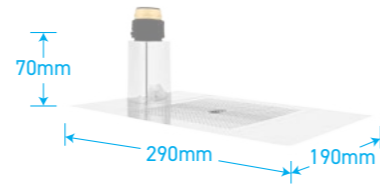

FINISH OPTIONS

CH	BR	MB	MW
Chrome	Brushed	Matte Black	Matte White

Special order finishes are available. Special orders only.

Font with 120mm Riser

Suitable for: **XL** **XT** **XR**

Product Code: 992803

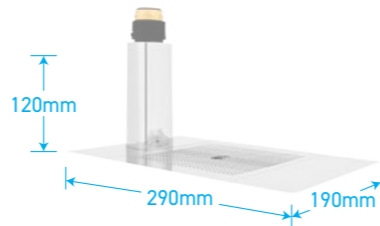

FINISH OPTIONS

CH	BR	MB	MW
Chrome	Brushed	Matte Black	Matte White

Special order finishes are available. Special orders only.

Slimline Font

Suitable for: **R** **S** **E**

Product Code: 992810

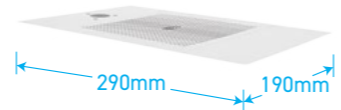

FINISH OPTIONS

CH	BR	MB	MW
Chrome	Brushed	Matte Black	Matte White

70mm Riser

Suitable for: **XL** **XT** **XR**

Product Code: 992820



FINISH OPTIONS

CH	BR	MB	MW
Chrome	Brushed	Matte Black	Matte White

Special order finishes are available. Special orders only.

120mm Riser

Suitable for: **XL** **XT** **XR**

Product Code: 992830

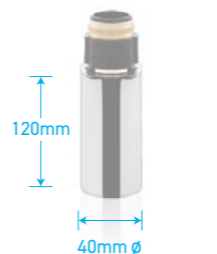

FINISH OPTIONS

CH	BR	MB	MW
Chrome	Brushed	Matte Black	Matte White

Special order finishes are available. Special orders only.



Tubing Extension Kit for X series dual temp dispensers - 2mtrs

Suitable for: **XL** **XT** **XR**

Product Code: 990720

1mtr version also available, Product Code: 990712



Tubing Extension Kit for Plus units - 1.8mtrs

Suitable for: **P** **G** **S**

Product Code: 990714



Tubing Extension Kit for Slimline Tap - 2mtrs

Suitable for: **R** **S** **E**

Product code: 990724



Tubing Extension Kit for Sparkling units - 2mtrs

Suitable for: **L**

Product code: 990726



Tubing Extension Kit for Slimline Sparkling units - 2mtrs

Suitable for: **D**

Product code: 990727



CO2 Cylinder

Suitable for: All Billi Underbench Sparkling Units

Product Codes: 996911 - Single (1.1kg)
996912 - 2 Pack (2 x 1.1kg)



SUSTAINABLE CO2

Refillable CO2 Cylinder Now Available

To see if refillable CO2 is available in your area or to arrange a refillable CO2 plan please contact Billi on 1800 812 321 or billicare@billi.com.au

"The Billi hot & filtered cold tap is by far the more superior product in my experience. There are 4 reasons for this. Firstly, we love the ease with which the Filter Cartridges - just slot in and click into place for replacement, couldn't be simpler. The second major advantage is the reduced and more efficient unit size that sits underneath in the cabinet below - it takes up far less room than the competitor offering. Importantly, the price point is by far lower, a real no brainer! And lastly, the unit is reliable and looks fabulous. I could not recommend the Billi tap enough. It isn't my first Billi tap, and it won't be my last"

Regina, Vic

"Excellent customer service, from advice, to Sales, installation and beyond. Staff are super friendly, helpful and thoughtful. Really happy with the co-written experience and the end product. I have one happy family especially a young person with different needs. Thanks, so much for going the extra mile for us"

Kerrin, AU

"We absolutely love our Billi boiling and chilled water dispenser. It's so convenient to have instant hot and cold water when you need it. It's also great to have that more uncluttered look in the kitchen, now that we don't need a kettle on the benchtop. The Billi looks classy, but unobtrusive. We've very pleased with our purchase and would recommend this product highly"

Rola, Sydney

"Such a convenient and good looking appliance. There isn't a day that goes by where we don't use our Billi. Easily pour boiling, chilled or sparkling filtered water at the touch of a button. This is our 2nd one, we moved into a house that didn't have a Billi and had to put one in!"

Fotis, Melbourne



Billi's new online 3D Build mobile innovation allows you to simply specify, then shop from the comfort of your home.

Build your own filtered water system at: www.billi.com.au/3d-build



Chrome XL Levered Dispenser with 70mm riser and matching font



Matte Black Paddle Lever Mixer and Matte Black XL Levered Dispenser with matching 70mm riser



BOILING

Billi Ultra

The Billi Ultra is a cost effective source of instant boiling water at the touch of a lever.

This wall mounted unit is ideal for commercial environments.



Product Code	Model	Initial delivery capacity cups	Boiling water delivery (cups per hour)	Heating Element (kW)
910030	Ultra 300	20	170	2.4
910060	Ultra 600	38	188	2.4
910080	Ultra 800	50	200	2.4
910160	Ultra 1600	100	250	2.4
910250	Ultra 2500	160	310	2.4



CHILLED

RM 33 Bubbler

Delivering up to 30 litres of chilled water per hour, the RM Bubbler satisfies the hydration needs of demanding public & community environments such as schools, fitness centres & stadiums, factories & workshops more. Made from tough, durable materials, this bubbler is perfectly suited to outdoor areas and locations that are usually exposed to harsh weather and rough-use conditions.

FEATURES

- IP 33 Rating
- Capacity suitable for high volume areas
- 100% rust proof and UV stabilised cabinet to prevent material degradation
- Includes standard drinking spout and convenient bottle filler
- Impact resistant construction
- Strong built and dependable, ideal for outside environments
- Granite style finish



Product Code	Model	Capacity	Chilled water delivery glasses per hour	Power supply (amps)
988016	RM 33 Bubbler	30L/hour	175*	10

Water temperature at 5°C.

*Based on the initial number of glasses of chilled water immediately available, drawn one cup every 10 seconds.



CHILLED



SPARKLING

Billi Alpine Spring

Ideal for corporate kitchens, boardrooms and office environments. Enjoy bottomless chilled and sparkling water on tap with this compact underbench system. The versatile sparkling suite offers two additional higher capacity models to suit the needs of any commercial or hospitality space.

FEATURES

- Provides instant access to premium sparkling water on tap
- Ice Bank water cooling system delivers high volumes of consistently ice cold water (3°C - 10°C)
- Compact underbench system
- Ideal for corporate offices, kitchens and boardrooms
- High performance filtration
- The only HACCP certified sparkling water system in Australia

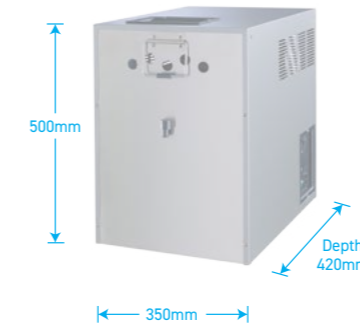

65L Underbench Unit



120L Underbench Unit

Product Code	Model	Capacity per hour	Water options	Suggested no. of people	Dispenser
842205	Alpine Spring 65 Unit with Double Cobra Head Dispenser. Includes Accessories and Installation Kit	65L	CHILLED SPARKLING	Up to 100	Double Cobra Head
842206	Alpine Spring 120 Unit with Triple Cobra Head Dispenser. Includes Accessories and Installation Kit	120L	CHILLED SPARKLING STILL	Up to 150	Triple Cobra Head



Hands Free Sensor Taps

Billi's sensor tap range has a unique electronic sensor built into the spout which automatically detects hand movement in the hand washing zone and shuts off as soon as you move your hands away, reducing water wastage. Available in wall or bench mount options.

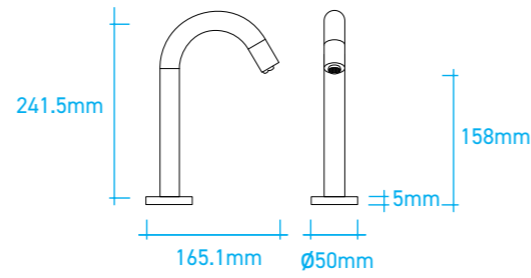

FINISH OPTIONS

- CH**
Chrome
- BR**
Brushed
- MB**
Matte Black
- BB**
Brushed Brass (Special orders only)

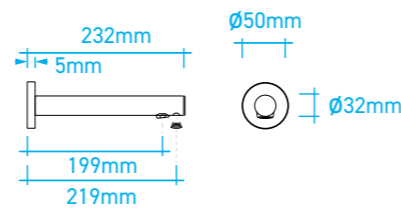
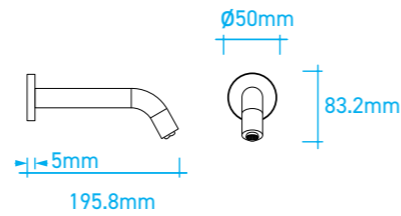

Hands Free Soap Dispensers

Offering a touchless handwashing experience, Billi's hands free soap dispensers featuring a 1000ml reservoir and battery or mains power supply. Available in wall or bench mount options.

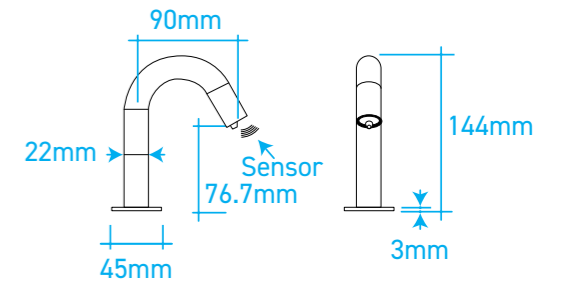

FINISH OPTIONS

- CH**
Chrome
- BR**
Brushed
- MB**
Matte Black
- BB**
Brushed Brass (Special orders only)

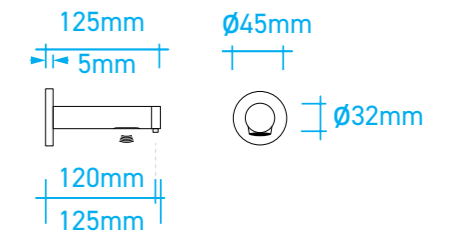
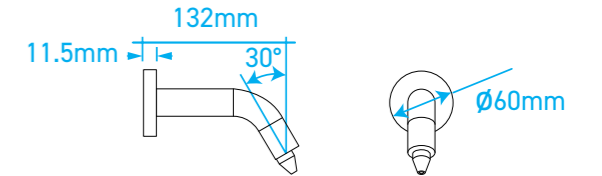

Product Code	Model	WELS rating	Flow rate
961000	Bench Mount Sensor Tap	6 Star	4 litres / min.
961100	Wall Mount Sensor Tap	6 Star	4 litres / min.
961300	Straight Wall Mount Sensor Tap	6 Star	4 litres / min.

Product Code	Model	Reservoir Size	Max. dispense time
982410	Bench Mount Sensor Soap Dispenser	1000ml	10 seconds
982411	Wall Mount Sensor Soap Dispenser	1000ml	10 seconds
982412	Straight Sensor Soap Dispenser	1000ml	10 seconds



Hands-free sensor tap wall mounted



Hands-free sensor tap straight wall mounted

Underbench Units

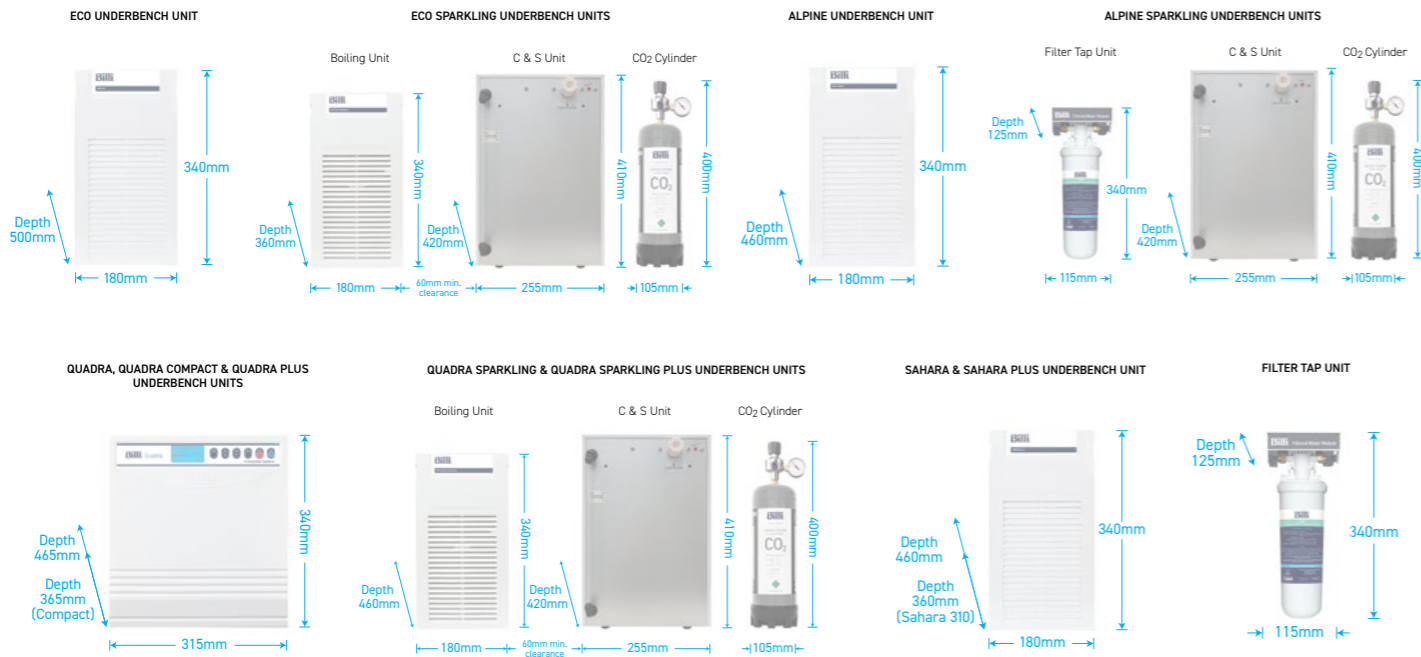

Dispensers

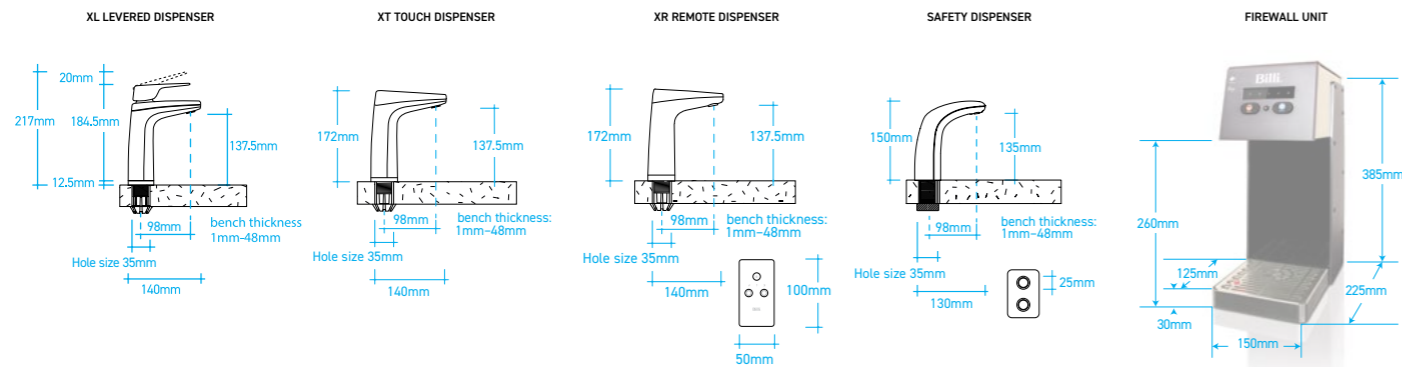

Slimline Dispensers

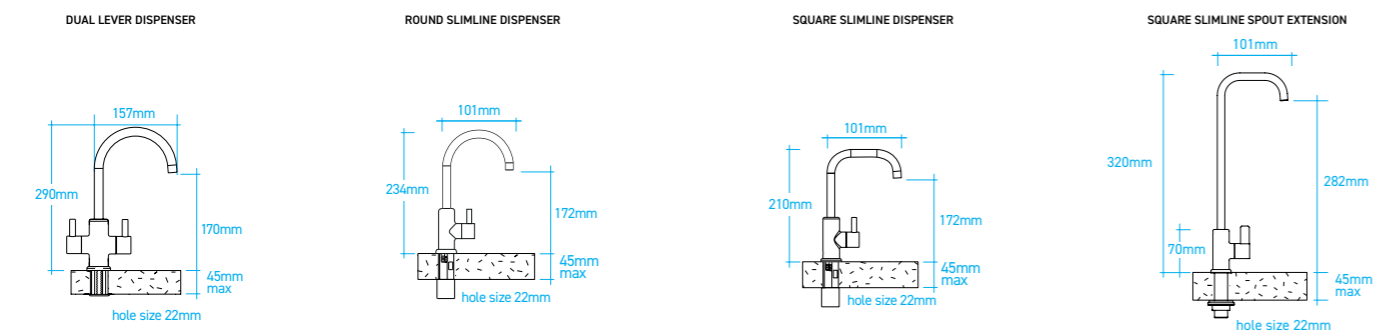

Mixer Taps

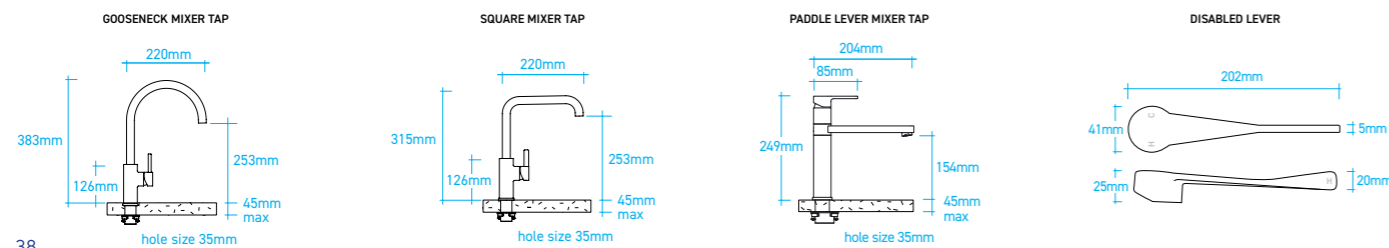

Accessories

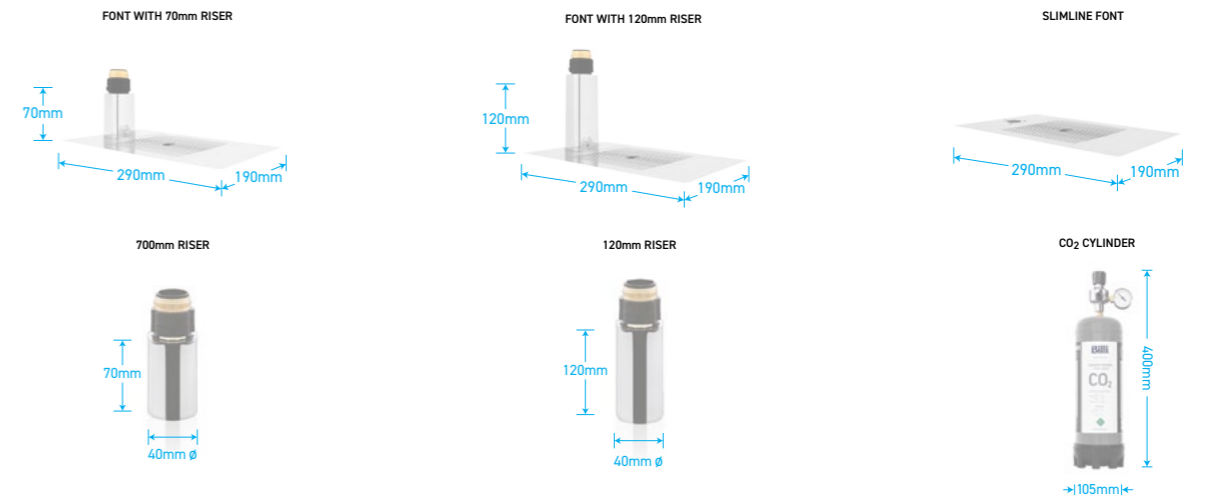

Hands Free Sensors

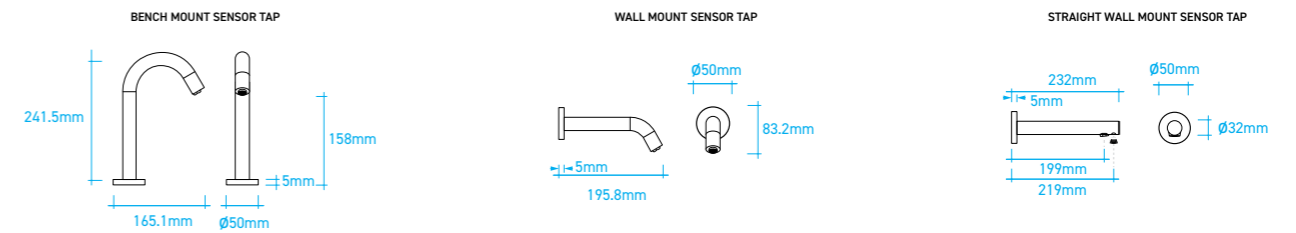

Bench Mount Soap Sensor Dispenser

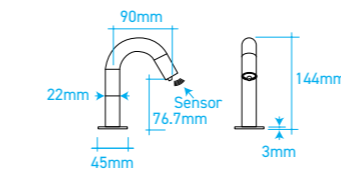

Wall Mount Soap Sensor Dispenser

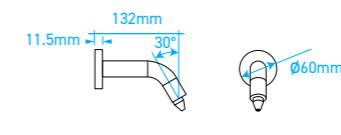

Wall Mount Straight Soap Sensor Dispenser

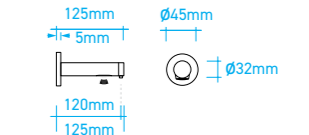

Others

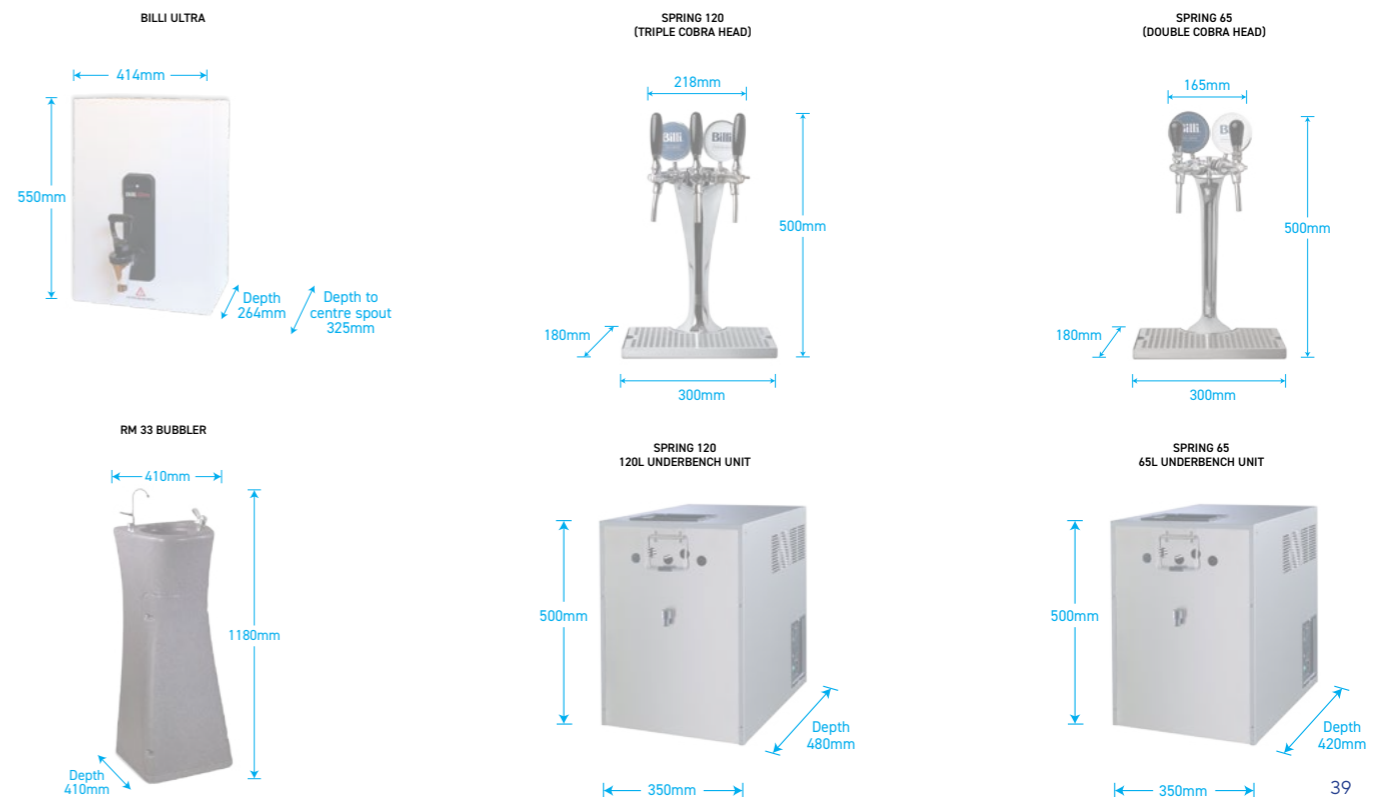

To quickly find your model or our new 3D Build visit:
www.billi.com.au/products/spec-generator
www.billi.com.au/3d-build

1 CHOOSE YOUR UNDERBENCH UNIT

Combination	Suggested No. of People	Product Description	Code
	Up to 10	Billi Eco	901000
	Up to 20	Billi Quadra Compact	904010
	Up to 25	Billi Quadra 420	904020
	Up to 40	Billi Quadra 440	904040
	Up to 60	Billi Quadra 460	904060
	Up to 100 Up to 180	Billi Quadra 4100 Billi Quadra 4180	904100 904180
	Up to 10	Billi Sahara 310	943010
	Up to 20	Billi Sahara 320	943020
	Up to 60	Billi Sahara 360	943060
	Up to 120	Billi Sahara 3120	943120
	Up to 20	Billi Alpine 125	932125
		Up to 10	Billi Eco Sparkling
Up to 60		Billi Quadra Sparkling 460	906060
Up to 100		Billi Quadra Sparkling 4100	906100
	Up to 60	Billi Quadra Sparkling Plus 9	906065
	Up to 110	Billi Quadra Sparkling Plus 15	906105
	Up to 25	Billi Quadra Plus 5	904025
	Up to 60	Billi Quadra Plus 9	904065
	Up to 100	Billi Quadra Plus 15	904105
	Up to 20	Billi Sahara Plus 320	943025
	Up to 60	Billi Sahara Plus 360	943065
	Up to 100	Billi Sahara Plus 3120	943125
	Up to 40	Billi Alpine Sparkling 100	933100
	Up to 80	Billi Alpine Sparkling 200	933200
	Up to 12	Billi Alpine 060	932060
	Up to 20	Billi Alpine 120	932120
	Unlimited	Billi Filter Tap	932210

2 CHOOSE YOUR DISPENSER DESIGN

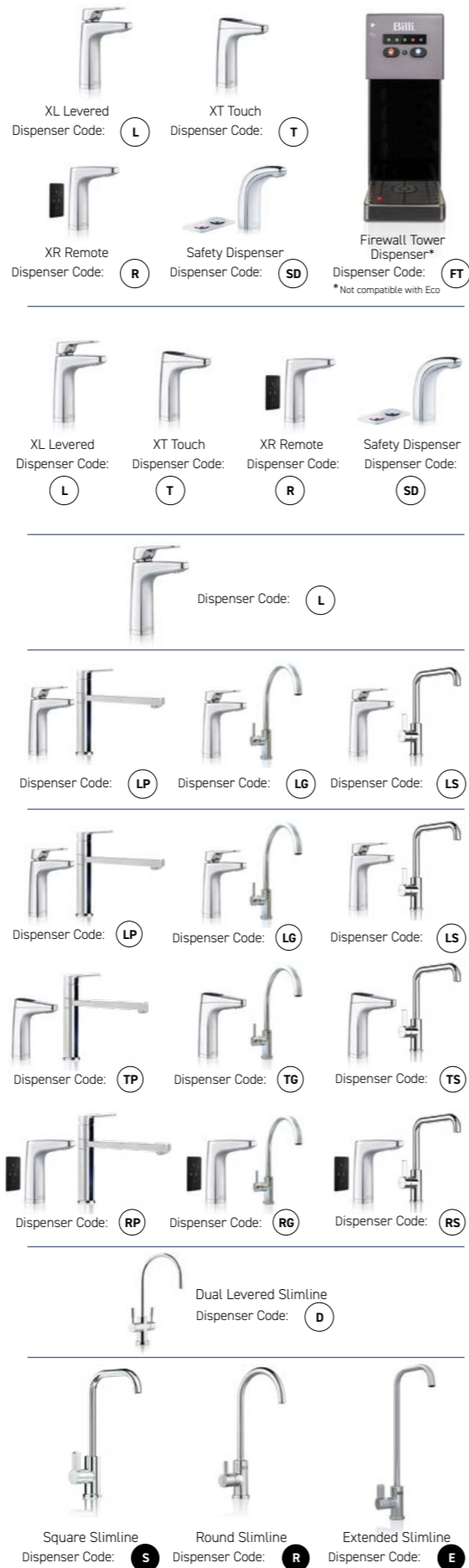

XL Levered Dispenser Code: **L**
XT Touch Dispenser Code: **T**
XR Remote Dispenser Code: **R**
Safety Dispenser Dispenser Code: **SD**
Firewall Tower Dispenser* Dispenser Code: **FT**
*Not compatible with Eco

XL Levered Dispenser Code: **L**
XT Touch Dispenser Code: **T**
XR Remote Dispenser Code: **R**
Safety Dispenser Dispenser Code: **SD**

Dispenser Code: **L**

LP Dispenser Code: **LP**
LG Dispenser Code: **LG**
LS Dispenser Code: **LS**

TP Dispenser Code: **TP**
TG Dispenser Code: **TG**
TS Dispenser Code: **TS**

RP Dispenser Code: **RP**
RG Dispenser Code: **RG**
RS Dispenser Code: **RS**

Dual Levered Slimline Dispenser Code: **D**

Square Slimline Dispenser Code: **S**
Round Slimline Dispenser Code: **R**
Extended Slimline Dispenser Code: **E**

3 CHOOSE YOUR DISPENSER FINISH

See Pages 23 - 27 for available finishes on each dispenser.

FINISHES

CH
Chrome

BR
Brushed

MB
Matte Black

MW
Matte White

SPECIAL ORDER FINISHES

RG
Rose Gold

PL
Platinum

BRG
Brushed Rose Gold

UB
Urban Brass

GM
Gun Metal Grey

4 CHOOSE YOUR OPTIONAL ACCESSORIES

Type	Suits dispenser types	Code	Finishes
Font with 70mm Riser	XL XT XR	992800	FINISHES CH Chrome BR Brushed MB Matte Black MW Matte White
Font with 120mm Riser	XL XT XR	992803	SPECIAL ORDER FINISHES Special order finishes are available on some items, please contact your Billi representative for availability. RG Rose Gold PL Platinum BRG Brushed Rose Gold UB Urban Brass GM Gun Metal Grey
70mm Riser	XL XT XR	992820	
120mm Riser	XL XT XR	992830	
Slimline Font	R S E D	992810	
*Font tray grates supplied with standard finishes only.			
Tubing Extension Kit	XL XT XR	990720	N/A
Tubing Extension Kit - Plus Systems	P G S	990714	N/A
Tubing Extension Kit - Slimline Dispensers	R S E	990724	N/A
Tubing Extension Kit - Sparkling Units	L	990726	N/A
Tubing Extension Kit - Slimline Sparkling units	D	990727	N/A



Quality
ISO 9001



WaterMark



*On Eco, Quadra and Quadra Plus models only.



Standard Warranty

All components of the drinking water systems are covered by a 24-month warranty. The washroom range is covered by a 12 month warranty.

Commitment to Quality

A strong commitment to quality is as important to Billi as style, function and innovation. Recognising the importance of reliability to customers, all Billi water systems are manufactured to strict quality standards.

Every system is designed to provide the highest possible standards of efficiency and energy savings.

Certifications

Every Billi drinking water appliance is manufactured under a certified quality control system. They have been tested and comply with all relevant standards.

Billi **Eco, Eco Sparkling, Quadra, Quadra Sparkling, Quadra Plus, Quadra Sparkling Plus, Billi Sahara** and **Sahara Plus** systems are tested to and comply with; Watermark license number WM-21525, AS3498.

Billi **Alpine** and **Filter Tap** systems are tested to and comply with; Watermark license number WM-21882, ATS 5200:105.

Billi **Firewall Tower Dispenser** Watermark License Number 022974; Tested to AS/NZS4020; SAA 202198

BWT filter models 994051, 99052, 994054, 994055, 994056 & 994060 are tested to and comply with; Watermark license number WM-022902

All Billi systems are also tested to AS/NZS 4020; AS1428 Accessibility Design Requirements. Billi is also ISO 9001 Certified Certificate Number QEC11627.

Billi **Eco, Quadra** and **Quadra Plus** products are certified Gold Level under Global GreenTag standards.

Billi's range of Filter, Mixer and Sensor taps are Watermarked and licensed under WELS T26065, T26149, T29334, T29342, T29494, T30968, T31455 and T36026.

Billi systems are certified under HACCP PE-972-WAT-1-02.



Billi®

Billi Australia Pty Ltd

42 Lucknow Crescent,
Thomastown, Victoria
3074 Australia

P 1800 812 321
F +61 3 9469 0499
W www.billi.com.au

visit us at



Billi® is a registered trademark of Billi Australia Pty Ltd. All rights reserved. © Copyright protected.
As Billi Australia Pty Ltd has a policy of continual improvement, all details are subject to change without notice.
All goods are sold subject to our published terms and conditions.

0922