

---

# XTRA TILE

---

DUR **S** LAB

---

# **XTRA** **T I L E**

**DUR** **S** **LAB**

# LA NUEVA DIMENSIÓN CERÁMICA

DURSLAB

The new ceramic dimension

120x280x0,6 / 120x120x0,9 cm.

48"x110"x0,23" / 48"x48"x0,35"

Acorde a la política de innovación habitual en Durstone, presentamos nuestra nueva línea de producto DURSLAB: una cuidada selección de piezas porcelánicas en formatos 120x280x0,6 y 120x120x0,9.

La variedad gráfica de esta colección abarca desde los eternos mármoles de elegante veta hasta los básicos blanco y negro, pasando por el cemento más contemporáneo y minimalista.

Con la disponibilidad de los acabados pulido y soft las posibilidades estéticas aumentan facilitando la realización de proyectos vanguardistas y muy personales.

In line with Durstone's usual policy of innovation, we present our new DURSLAB product line: a careful selection of porcelain pieces in 120x280x0.6 and 120x120x0.9 formats.

The graphic variety of this collection ranges from the eternal marbles with elegant veining to the basic black and white, through the most contemporary and minimalist cement.

With the availability of polished and soft finishes, the aesthetic possibilities increase, facilitating the realization of avant-garde and very personal projects.

Estas magníficas piezas cuentan con un gran número de ventajas que las convierten en auténticas XtraTiles:

These magnificent pieces have a large number of advantages that make them true XtraTiles:

## XTRA DISEÑO

### XTRA Design

Naturalidad en su máximo exponente: gráficas 100% realistas.

Naturalness at its best: 100% realistic graphics.

## XTRA RESISTENCIA

### XTRA Resistance

Soporte porcelánico con absorción de agua inferior al 0,5%, y excelentes prestaciones: resistencia al hielo, al rayado, a las variaciones de temperatura y a las manchas más comunes.

Porcelain backing with water absorption of less than 0.5%, and excellent performance: resistance to frost, scratching, temperature variations and the most common stains.

## XTRA VERSATILIDAD

### XTRA Versatility

Múltiples usos al margen de los habituales en paredes y suelo: bancos e islas en cocina, mesas, estanterías, chimeneas o recubrimiento de muebles son sólo algunas de las opciones.

Multiple uses beyond the usual uses on walls and floors: benches and kitchen islands, tables, shelves, fireplaces, or furniture coverings are just some of the options.

## XTRA HIGIENE

### XTRA Hygiene

Superficies no absorbentes, fáciles de limpiar e higienizar.

Non-absorbent surfaces, easy to clean and sanitize.

# ARK

📷 5 / 12 / 18 📏 22 / 23

# BIANCO CORTINA

📷 14 📏 24

# MARMI VECCHIO

📷 18 📏 25

# MATERIA

📷 6 📏 26 / 27 / 28

# SOLID

📷 8 / 10 / 16 / 20 📏 29 / 30

# STATUS DELUXE

📷 9 / 11 / 15 / 20 📏 31

# T-STONE

📷 10 📏 32 / 33 / 34

# YVES NERO

📷 5 📏 35

# DECOR HAVANA

📷 20 📏 36

# DECOR NATURE

📷 8 📏 37

**WALL**  
Yves Nero Soft 120x280

**FLOOR**  
Ark Beige 120x120





---

**WALL**  
Materia Pepper Natural  
120x280  
Materia Pearl Natural  
120x280

**FLOOR**  
Materia Pearl Natural  
120x120



**WALL**  
Decor Nature 120x280  
Solid Bianco Soft 120x280  
Imagine Blue Brillo 6x25

**FLOOR**  
Solid Bianco Soft 120x120

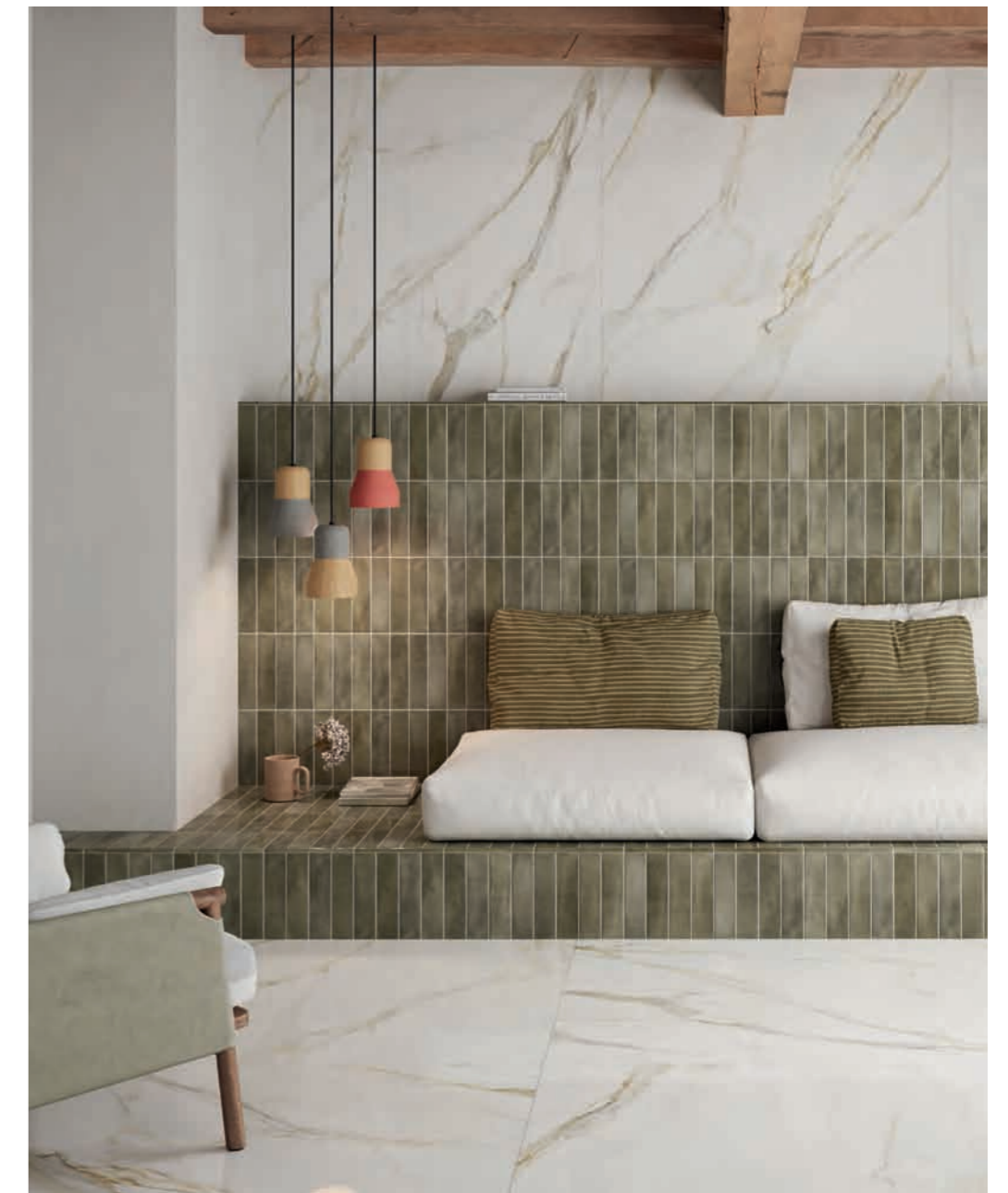

**WALL**  
Status Deluxe Pulido 120x280  
Imagine Olive Brillo 6x25

**FLOOR**  
Status Deluxe Pulido 120x120



**WALL**  
Status Deluxe Soft 120x280

**FLOOR**  
Status Deluxe Soft 120x120

**WALL**  
T-Stone Crema Natural 120x280

**TABLE:**  
T-Stone Avorio 120x280

**FLOOR**  
Solid Nero Soft 120x120

**WALL**  
Ark Grigio Natural  
120x280

**FLOOR**  
Ark Grigio Natural  
120x120







**WALL**  
Status Deluxe Pulido 120x280

**FLOOR**  
Heritage Maple Natural 30x120

**COUNTERTOP**  
Bianco Cortina Pulido 120x280

**FLOOR**  
Bianco Cortina Pulido 120x120

**WALL**  
Solid Nero Soft 120x280

**FLOOR**  
Irati Teak Natural 30x120



**WALL**  
Marmi Vecchio Pulido 120x280

**FLOOR**  
Marmi Vecchio Pulido 120x120

**WALL**  
Ark Beige Natural 120x280

**FLOOR**  
Ark Beige Natural 120x120





---

**WALL**  
Decor Havana 120x280

**COUNTERTOP**  
Status Deluxe Pulido

**FLOOR**  
Solid Nero Soft 120x120

# ARK

PORCELÁNICO



**120x280x0,6 / 120x120x0,9 cm.**

48"x110"x0,23" / 48"x48"x0,35" approx.

**NATURAL**

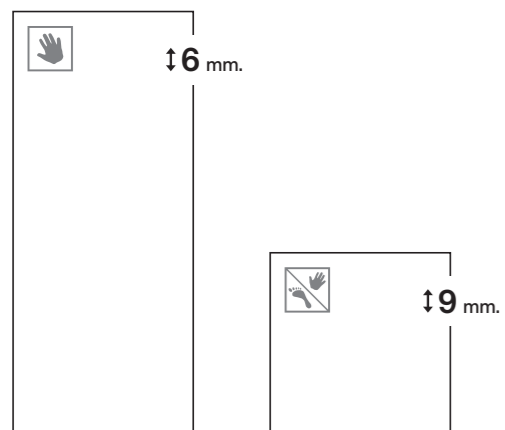

Ark Beige  
120x280  
Natural DUR4850

Ark Beige  
120x120  
Natural DUR4650



Beige

# ARK

PORCELÁNICO



**120x280x0,6 / 120x120x0,9 cm.**

48"x110"x0,23" / 48"x48"x0,35" approx.

**NATURAL**

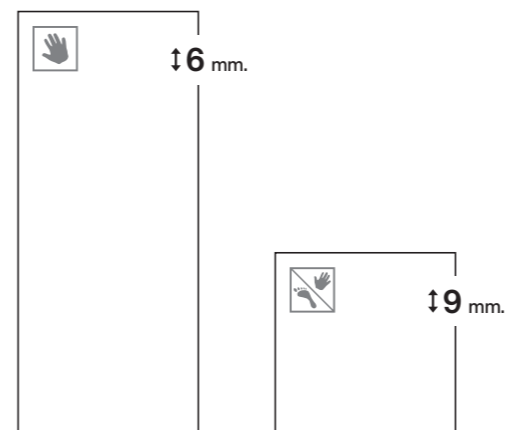

Ark Grigio  
120x280  
Natural DUR4850

Ark Grigio  
120x120  
Natural DUR4650



Grigio

# BIANCO CORTINA



120x280x0,6 / 120x120x0,9 cm.

48"x110"x0,23" / 48"x48"x0,35" approx.

PULIDO  
SOFT

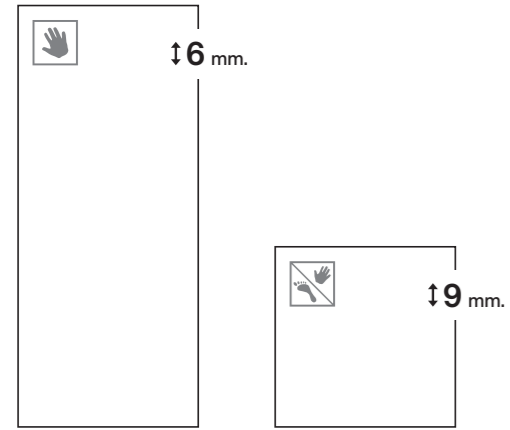

Bianco Cortina  
120x280

Pulido DUR7000  
Soft DUR4850

Bianco Cortina  
120x120

Pulido DUR4800  
Soft DUR4650

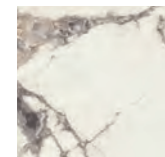

Bianco Cortina

PORCELÁNICO

# MARMI VECCHIO



120x280x0,6 / 120x120x0,9 cm.

48"x110"x0,23" / 48"x48"x0,35" approx.

PULIDO  
SOFT

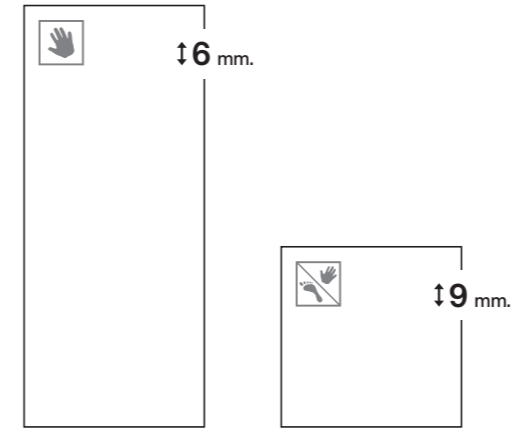

Marmi Vecchio  
120x280

Pulido DUR7000  
Soft DUR4850

Marmi Vecchio  
120x120

Pulido DUR4800  
Soft DUR4650



Marmi Vecchio

PORCELÁNICO

# MATERIA

PORCELÁNICO



**120x280x0,6 / 120x120x0,9 cm.**

48"x110"x0,23" / 48"x48"x0,35" approx.

**NATURAL**

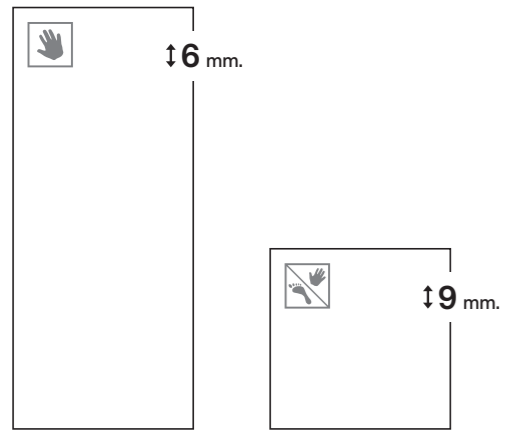

**Materia Pearl**  
120x280  
Natural DUR4850

**Materia Pearl**  
120x120  
Natural DUR4650



Pearl

# MATERIA

PORCELÁNICO



**120x280x0,6 / 120x120x0,9 cm.**

48"x110"x0,23" / 48"x48"x0,35" approx.

**NATURAL**

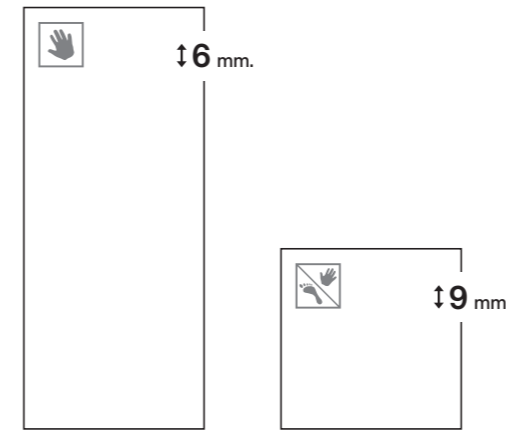

**Materia Ash**  
120x280  
Natural DUR4850

**Materia Ash**  
120x120  
Natural DUR4650



Ash

# MATERIA

PORCELÁNICO



120x280x0,6 / 120x120x0,9 cm.

48"x110"x0,23" / 48"x48"x0,35" approx.

NATURAL

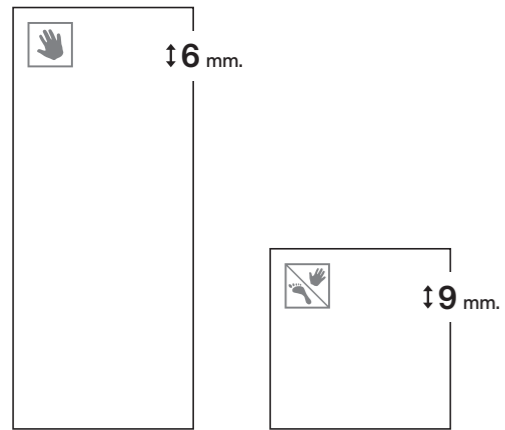

Materia Pepper  
120x280

Natural DUR4850

Materia Pepper  
120x120

Natural DUR4650



Pepper

# SOLID

PORCELÁNICO



120x280x0,6 / 120x120x0,9 cm.

48"x110"x0,23" / 48"x48"x0,35" approx.

PULIDO

SOFT

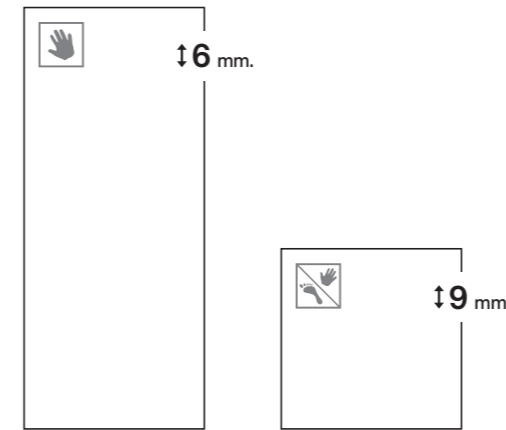

Solid Bianco  
120x280

Pulido DUR7000  
Soft DUR4850

Solid Bianco  
120x120

Pulido DUR4800  
Soft DUR4650



Bianco



# SOLID

PORCELÁNICO



**120x280x0,6 / 120x120x0,9 cm.**

48"x110"x0,23" / 48"x48"x0,35" approx.

**SOFT**

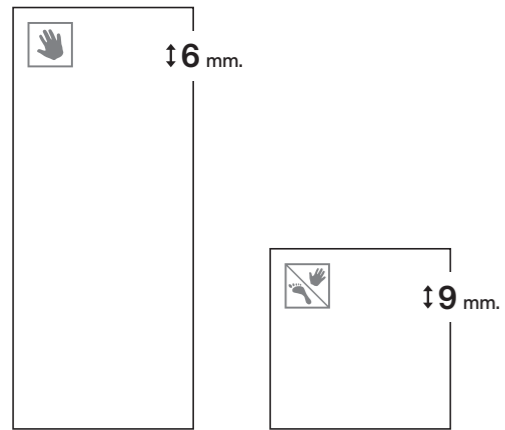

Solid Nero  
120x280

Soft DUR4850

Solid Nero  
120x120

Soft DUR4650



Nero

30

# STATUS DELUXE

PORCELÁNICO



**120x280x0,6 / 120x120x0,9 cm.**

48"x110"x0,23" / 48"x48"x0,35" approx.

**PULIDO**

**SOFT**

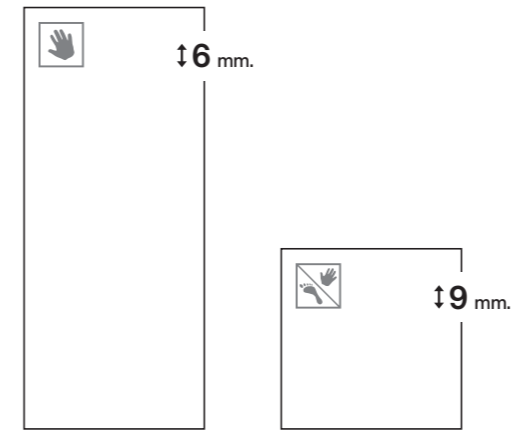

Status Deluxe  
120x280

Pulido DUR7000  
Soft DUR4850

Status Deluxe  
120x120

Pulido DUR4800  
Soft DUR4650

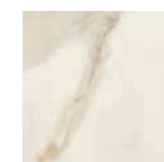

Status Deluxe

31

# T-STONE

PORCELÁNICO



**120x280x0,6 / 120x120x0,9 cm.**

48"x110"x0,23" / 48"x48"x0,35" approx.

NATURAL

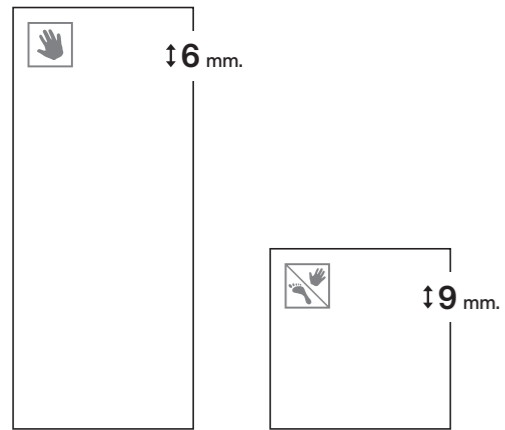

T-Stone Avorio  
120x280

Natural DUR4850

T-Stone Avorio  
120x120

Natural DUR4650



Avorio

# T-STONE

PORCELÁNICO



**120x280x0,6 / 120x120x0,9 cm.**

48"x110"x0,23" / 48"x48"x0,35" approx.

NATURAL

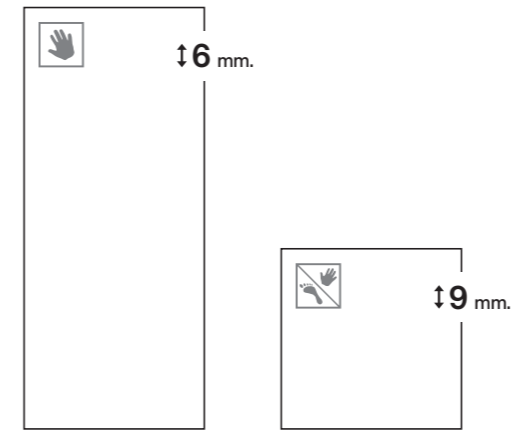

T-Stone Crema  
120x280

Natural DUR4850

T-Stone Crema  
120x120

Natural DUR4650



Crema

# T-STONE

PORCELÁNICO



**120x120x0,9 cm.**

48"x48"x0,35" approx.

**NATURAL**

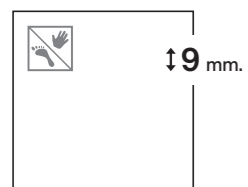

T-Stone Grey  
120x120  
Natural DUR4650



Grey

34

# YVES NERO

PORCELÁNICO



**120x280x0,6 / 120x120x0,9 cm.**

48"x110"x0,23" / 48"x48"x0,35" approx.

**PULIDO**

**SOFT**

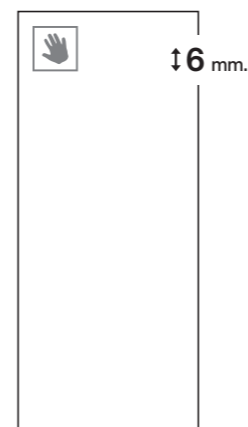

Yves Nero  
120x280  
Pulido DUR7000  
Soft DUR4850

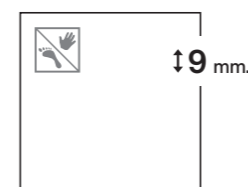

Yves Nero  
120x120  
Pulido DUR4800  
Soft DUR4650

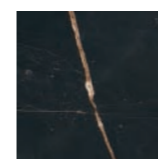

Yves Nero

35

# DECOR HAVANA



120x280x0,6 cm.

48"x110"x0,23" approx.

MATE

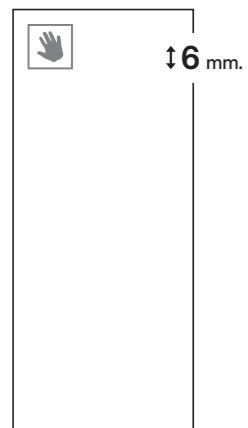

Decor Havana  
120x280  
Mate PESP15000

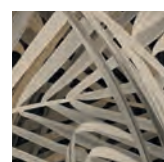

Decor Havana

36

PORCELÁNICO



# DECOR NATURE



120x280x0,6 cm.

48"x110"x0,23" approx.

MATE

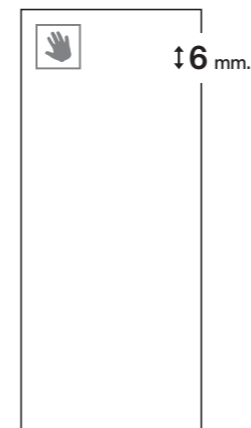

Decor Nature  
120x280  
Mate PESP15000



Decor Nature

PORCELÁNICO

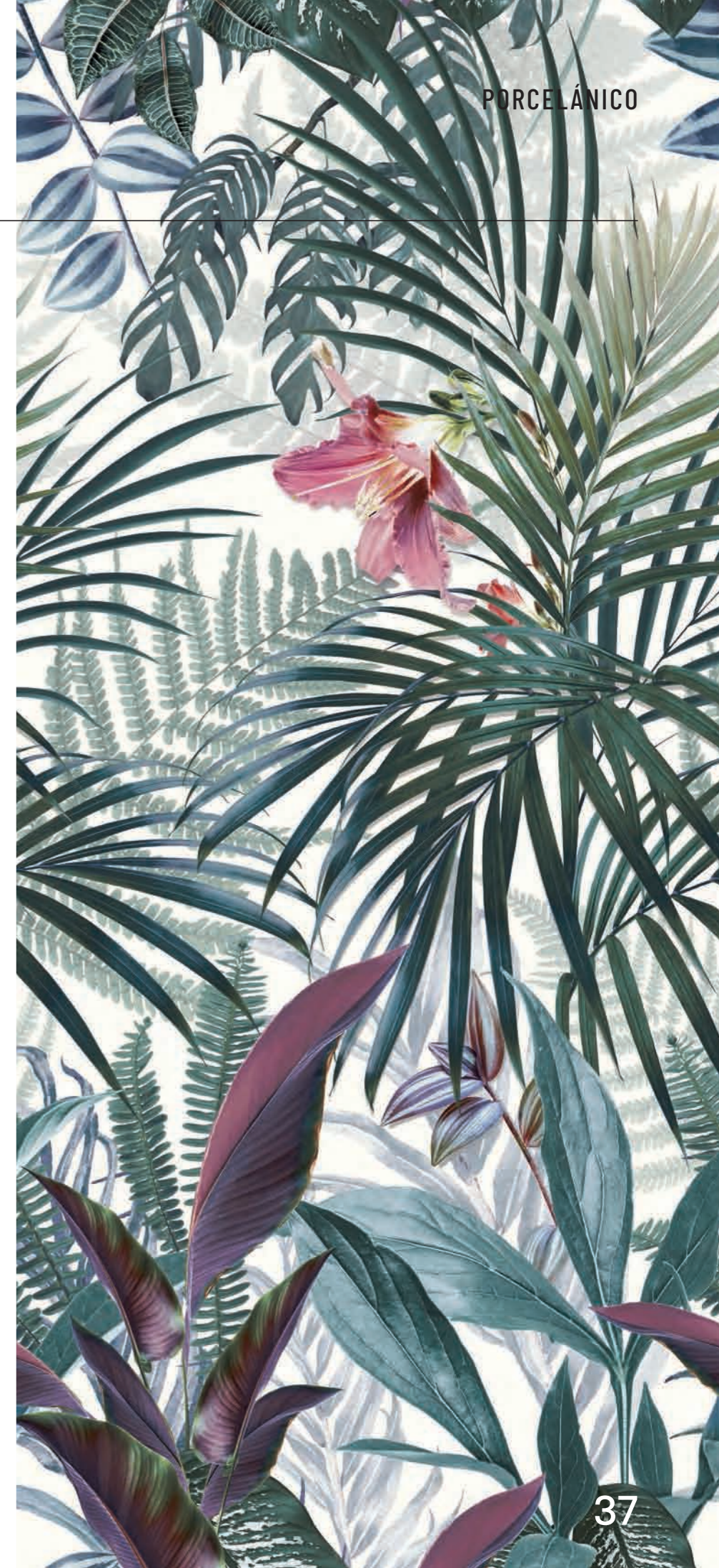

37

## LIMPIEZA Y MANTENIMIENTO

### Limpieza tras la instalación

Las piezas DURSLAB presentan una superficie resistente a las manchas, higiénica y de fácil mantenimiento. Para que estas características perduren en el tiempo es indispensable realizar una cuidadosa limpieza nada más terminar su instalación para eliminar cualquier residuo que pueda crear una película en la superficie que retenga la suciedad. Retirar tarde o de forma inadecuada los residuos de cemento, silicona o adhesivo puede producir manchas difíciles de retirar posteriormente.

Es por esto que la limpieza inicial ha de realizarse inmediatamente tras la instalación, utilizando productos de base ácida, frotando enérgicamente y enjuagando bien con agua abundante. Esto permitirá la eliminación de residuos de adhesivo, cemento, silicona y demás restos de obra. Se pueden utilizar todos los detergentes disponibles en el mercado con la única excepción de los productos que contengan ácido fluorhídrico (compuestos y derivados) según la norma EN 14411.

Siga cuidadosamente las instrucciones facilitadas por el fabricante en el paquete del producto de limpieza utilizado. Antes de limpiar la superficie instalada siempre es mejor realizar una prueba primero en una muestra del material que no se haya instalado o en un área pequeña y poco visible.

Recomendamos el uso de un limpiador ácido (ej: Detertek – Filasolutions). Los residuos de lechada epoxi deben eliminarse con un limpiador alcalino (ej. Fila CR10 - Filasolutions). En productos pulidos, no utilice limpiadores ácidos en altas concentraciones. Deben diluirse en agua al 10-15%

### Limpieza de rutina

Para la limpieza rutinaria, basta con seguir unas sencillas precauciones que son principalmente de sentido común, teniendo en cuenta las características del material.

- Utilizar detergentes neutros sin ceras diluidos en agua, siguiendo siempre las instrucciones de los envases.
- Utilizar suficiente agua limpia para realizar lavados frecuentes.
- No utilice productos ácidos o herramientas abrasivas, que pueden afectar a la superficie de los materiales pulidos y comprometer los materiales cementosos utilizados para el sellado.
- Se debe tener todo el cuidado posible para evitar la presencia de material del exterior que pueda causar rayas, como arena de cuarzo y otros materiales, ya que pueden causar abrasión de la superficie y reducir su brillo.

### Fachadas ventiladas

El aislamiento instalado detrás del revestimiento de la losa es más efectivo cuando está perfectamente seco; no utilice chorros de agua violentos. Recomendamos el uso de un limpiador neutro (ej.: FILACLEANER - filasolutions.com)

**Nota:** No se deben utilizar ceras, jabones aceitosos ni materiales de impregnación (hidrofugantes y oleofugantes) sobre el gres porcelánico.

CARACTERÍSTICAS TÉCNICAS TECHNICAL CHARACTERISTICS	NORMA STANDARD	PRESCRIPCIÓN DE LA NORMA (%) (mm) STANDARD REQUIREMENTS	RESULTADOS DEL TEST TEST RESULTS
Desviación admitida, en %, del espesor medio de cada baldosa con respecto a las dimensiones de producción / Admitted deviation, in %, of the average thickness of each tile from the production dimensions	<b>ISO 10545-2</b>	± 5%	± 5%
Planitud (curvatura en el medio, esquina y alabeo) Flatness (curving in the middle, corner and warping)	<b>ISO 10545-2</b>	±0,5% ±2 mm	±0,5% mm
Calidad de la superficie Surface quality	<b>ISO 10545-2</b>	Al menos el 95% de las baldosas deben estar libres de defectos visibles. / At least 95% of the tiles must be free from visible flaws.	Conforme / Compliant
% absorción de agua / % Water absorption	<b>ISO 10545-3</b>	< 0,5%	< 0,5%
Resistencia a la abrasión profunda de baldosas sin esmaltar Resistance to deep abrasion of unglazed tiles	<b>ISO 10545-6</b>	<175 mm3	Conforme / Compliant
Resistencia al choque térmico Thermal shocks resistant	<b>ISO 10545-9</b>	Método de prueba disponible Available testing method	Resiste / Résistant
Resistencia a las manchas Resistance to staining	<b>ISO 10545-14</b>	Certificado del fabricante Manufacturer’s certificate	Clase 5 (Nat. + Soft) / Classe 3-4 (Pul)
Resistencia a bajas concentraciones de ácidos y álcalis Resistance to low concentrations of acids and alkalis	<b>ISO 10545-13</b>	Certificado del fabricante Manufacturer’s certificate	ULA-ULB (Nat + Soft) / UB (Pul )
Resistencia a productos químicos domésticos y aditivos para piscinas / Resistance to domestic chemical products and additives for swimming pools		MIN B	UA
Resistencia al hielo / Frost resistance	<b>ISO 10545-12</b>	Requerido / Required	Resiste / Résistant

## CLEANING AND MAINTENANCE

### Cleaning after installation

DURSLAB pieces have a surface that’s resistant to stains, hygienic and easy to maintain; to preserve these characteristics, thorough cleaning must occur as soon as installation is completed, eliminating any residues that may create a film on the surface of the product capable of retaining more dirt. Insufficient or late removal of grout, silicone and adhesive residues may leave stains that are difficult to remove.

Initial cleaning must therefore take place immediately after installation, using acid-based products, rubbing hard and rinsing well with plenty of water. This will permit the elimination of adhesive, cement, silicone residues, etc. All detergents available on the market may be used with the sole exception of products containing hydrofluoric acid (compounds and derivatives) as per the EN 14411 standard.

Take care to follow the instructions provided by the producer on the pack of the product used. Before cleaning the surface installed, it is always best to test the cleaning agents first on a sample of the material which has not been installed, or on a small, not very visible area.

We recommend the use of an acid cleaner (e.g.: DETERDEK - filasolutions.com) Epoxy grout residues should be removed with an alkaline cleaner (e.g.: Fila CR10 - filasolutions.com). On polished products, do not use acid cleaners at high concentrations. They should be diluted in water to 10-15%.

### Routine cleaning

For routine cleaning, it is enough to follow a few simple precautions which are mainly common sense once the material’s characteristics are borne in mind.

- Use neutral, wax-free detergents diluted in water, always followin the instructions on the packs.
- Clean water may be sufficient for frequent washes.
- Do not use acidic products or abrasive tools, which may make the surface of lapped materials matt, and compromise the cement-based materials used for sealing.
- All possible care should be taken to prevent the presence of material from outdoors which may cause scratches, quartz sand and other materials, since they may cause abrasion of the surface and reduce its shine.

### Ventilated facades

The insulation installed behind the slab covering is most effective when perfectly dry; do not use violent water jets. We recommend the use of a neutral cleaner (e.g.: FILACLEANER - filasolutions.com)

**NB:** Waxes, oily soaps and impregnating materials (water and oil-repellents) should not be used on porcelain stoneware.

CARACTERÍSTICAS TÉCNICAS TECHNICAL CHARACTERISTICS	NORMA STANDARD	MÉTODO DE PRUEBA DESCRIPTION OF TEST METHOD	RESULTADOS DEL TEST TEST RESULTS
Fuerza de rotura n (sp. ≥ 7,5 mm: 1300 N   sp. < 7,5 mm: 700 N) Breaking strength in n (thk ≥ 7,5 mm: 1300 N   thk. < 7,5 mm: 700 N)	<b>ISO 10545-4</b>	Aplicación de una carga en la línea media del panel hasta obtener la rotura / Application of a load to the midline of the panel until breakage is obtained	Valor medio / Average value 1300 N
Resistencia a la flexión n/mm2 (≥ 35 N n/mm2) / N/mm2 flexural strenght test (≥ 35 N n/mm2)			Valor medio / Average value ≥ 40 N/mm2
Reacción al fuego Fire reaction	<b>UNI EN 13501-1</b>	Ensayo de suelo radiante UNI EN ISO 9293-1 Floor radiant panel test UNI EN ISO 9293-1	Clase A1fl+A1
Resistencia al impacto Impact resistance	<b>UNI EN ISO14617-9</b>	Resistencia a dejar caer una bola de acero de 1 kg sobre una muestra colocada sobre un lecho de arena. / Resistance to dropping a 1 kg steel ball on a sample placed on a bed of sand.	Conforme / Compliant
Coeficiente de retorno Coefficient of return	<b>UNI EN ISO10545-5</b>	Medida de la altura de rebote de una bola de acero de 28 g. / Measurement of 28 g steel ball rebound height.	Conforme / Compliant
Ensayos de emisión de compuestos orgánicos volátiles Volatile organic compound emission tests	<b>UNI EN ISO 16000-9</b>	28 días de duración de la prueba 28 days length-test	Conforme / Compliant
Fuerza de compresión Compression strength	<b>ASTM C170M-16</b>	Carga de rotura en muestras de 12x12x12 mm. Breaking load on 12x12x12 mm samples	Conforme / Compliant
Carga estática para suelos técnicos Static load for raised floors	<b>UNI EN ISO 12825</b>	Aplicación de carga creciente sobre muestra hasta obtener rotura / Increasing load application on the sample until breakage is obtained	Conforme / Compliant
Liberación de cadmio y plomo en mg/dm2 Cadmium and lead release in mg/dm2	<b>ISO 10545-15</b>	Solicitud de superficies GL para encimera Request for GL surfaces for work tops	Conforme / Compliant
Resistencia al calor húmedo / Resistance to damp heat	<b>UNI EN 12721:2013</b>	Ciclos de 55° a 100° / 55° to 100° cycles	Conforme / Compliant
Resistencia al calor seco / Resistance to dry heat	<b>UNI EN 12722:2013</b>	Ciclos de 55° a 100° / 55° to 100° cycles	Conforme / Compliant
Resistencia los líquidos fríos Resistance to cold liquids	<b>UNI EN 12720:2013</b>	Tiempo de contacto 10s a 24 h Period of contact 10s to 24 h	Conforme / Compliant
Tendencia a retener la suciedad Tendency to retain dirt	<b>UNI 9300:2015</b>	Agente de tinción negro carbón Carbon black staining agent	Sin cambios visibles No visible change
Resistencia al rayado Scratch resistance	<b>UNI EN 15186:2012 met B</b>	Carga > 10N / Load > 10N	Conforme (Superficie Nat.+ Soft) Compliant (Nat. + Soft Surface)
Resistencia a hongos Fungi resistance	<b>ASTM G 21-15</b>	Contacto durante 28 días con una variedad de cepas fúngicas / Contact for 28 days with a variety of fungal strains	Conforme / Compliant
Índice de reflectancia solar sri / solar reflectance index sri Light reflectance value lrv / light reflectance value lrv	<b>Met. Prueba interno In-house test method</b>	Iluminante D65 / Illuminant D65 Iluminante A / Illuminant A / Espectrofotómetro a 10° Spectrophotometer at 10°	En base al color / Based on the colour Disponible bajo petición / Available on reques
Resistencia de los colores a la decoloración Colours’ resistance to fading	<b>DIN 51094</b>	Evaluación de los cambios de color tras una exposición de 28 días a la luz ultravioleta / Evaluation of the color changes following a 28 day exposure to ultra violet light	Conforme / Compliant

PACKING LIST	TIPO EMBALAJE PACKING TYPE	FORMATO / SIZE	ESPESOR (mm) THICKNESS (mm)	PIEZAS PIECES	M2 TOTALES SQM TOTAL	KG EMBALAJE KG PACKING	KG TOTALES KG TOTAL	DIMENSIONES EMBALAJE (cm) PACKAGIN SIZES (cm)	
	Caja Crate	<b>120x280 / 48"x110"</b>	6	20	67,2	95	1.103	A: 144 / L: 291 / H: 34	
	Caballote Rack Pallet	<b>120x280 / 48"x110"</b>	6	36	121	120	1.935	A: 75 / L: 284 / H: 147,5	
TIPO EMBALAJE PACKING TYPE	FORMATO / SIZE	ESPESOR (mm) THICKNESS (mm)	PZAS/CAJA PCS/BOX	M2/CAJA SQM/BOX	KG/CAJA KG/BOX	CAJAS/PALLET BOXES/PALLET	M2/PALLET SQM/PALLET	KG/PALLET KG/PALLET	
	Caja Box	<b>120x120 / 48"x48"</b>	9	2	2,88	59,82	18	51,84	1.117

# DURSTONE

Este catálogo anula los anteriores. Los tonos y colores de las fotografías son una referencia a los modelos reales. CASA DEPOT SL (DURSTONE) no asume ninguna responsabilidad por errores de impresión en cualquier dato reflejado en el presente catálogo. Para la realización de cualquier pedido confirme los datos con CASA DEPOT SL (DURSTONE).

Todas las características y especificaciones técnicas están basadas en la información disponible en el momento de impresión del catálogo. CASA DEPOT SL (DURSTONE) se reserva el derecho de modificar, de acuerdo a las circunstancias de mercado y sin previo aviso, cualquier modelo, característica o prestaciones de sus productos sin que se contraiga derecho o perjuicio alguno.

This catalogue cancels the previous ones. Colors and tonalities of the pictures shown in this catalogue are a reference of the real models. CASA DEPOT SL (DURSTONE) does not take any responsibility of printing mistakes in any data of this catalogue. Check and confirm the data with CASA DEPOT SL (DURSTONE) before any order.

All technical characteristics and specifications are based on the available information at the printing moment. CASA DEPOT SL (DURSTONE) reserves the right to modify, according to changes in markets, and without any prior advice any model, characteristics or other information of its products without any responsibility or any commitment.

CV 20, AV / Mediterraneo, 52  
12200 - Onda (Castellón)  
Apdo. Correos 419

e-mail: [durstone@durstone.es](mailto:durstone@durstone.es)  
Tlf: 964 62 6134 - Fax: 964 626 135



---

DURSTONE



[www.durstone.es](http://www.durstone.es)

---