



Motorised Cable Reel

Built to the same exacting standards as our manual cable reels, these labour saving motorised reels are sturdy, rugged and built to reliably perform efficient pipeline inspections.

Minicam motorised cable reels are designed for easy one-person operation in remote locations. The reels are fitted with high tensile strength Kevlar reinforced inspection cable with a weight of 5.5kg per 100m and a breaking strength of 500kg. The ultra-smooth operation is provided by the powerful three phase motor and cable layering mechanism for uninterrupted, tangle free pay-out and re-winding. A rigid, clear safety screen prevents contact with the cable whilst coiling. In the event of an emergency, the reel also features an emergency stop button. The specialised crawler connector provides a waterproof seal and there's a removable drip tray for easy cleaning and maintenance. The reel is operated using the dedicated keys and intuitive on-screen display on the Proteus Control Unit.

Compatibility



Technical Data

	RAP200	RAP300
Cable Length	250 metres	350 metres
Dimensions (L x W x H)	530 x 320 x 520mm	530 x 440 x 520mm
Weight	30.5kg	40.5kg
Power Supply	24v	24v
Environmental Protection	IP54	IP54
Optional Remote Controller	RJP/RCP4	RJP/RCP4



Motorised Cable Reel

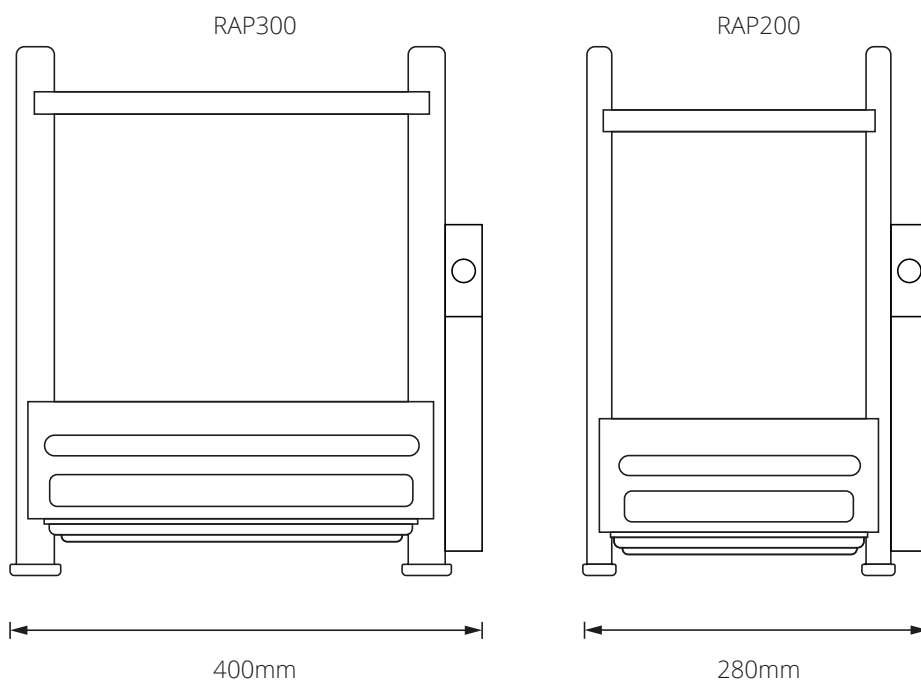

RAP300



RAP200