

VAN DER VALK



Installation manual



ValkPro+ L10° East-West

Version: v1.2.0
Date: 25-5-2021

Disclaimer

This installation manual needs to be used in conjunction with a project specific "Project report". This project report is the result of the use of the online calculation tool of Van der Valk Solar Systems B.V., called the "ValkPVplanner", which project report shows you specific information about your project such as, amongst other, a project drawing and ballast plan for flat roofs (the "Project Report"). This ValkPVplanner and the Project Report(s) derived from this ValkPVplanner are composed with the greatest possible care. Nonetheless, it is possible that some information might not be entirely correct as the results for each Project Report can be based on default values entered into this ValkPVplanner by you, which values always need to be checked and validated by you. The instructions provided in this Project Report must be strictly observed at all times, in addition to and in conjunction with the installation manual provided by us (the "Installation Manual"), and vice versa.

At all times all currently applicable structural, safety and building regulations must be observed when using the ValkPVplanner and/or Installation Manual. The building in question will be subject to a load as a result of the solar mounting system installed/mounted. Solar mounting systems installed on roofs will be exposed to wind and snow. Therefore, you are at all times responsible to obtain and use a design calculation to establish whether or not the building will be able to withstand the (extra) load at all times. Where necessary, modifications need to be made by you. Van der Valk will not accept any form of liability upon you not having obtained and used such a required design calculation.

Mounting systems for PV-panels on flat roofs should either be mechanically attached to the roof or need to be supported by ballast, to make sure that the solar mounting system is unable to be lifted, tipped over or slide. For each project, the required ballast weight per panel needs to be calculated using the ValkPVplanner software. The ballast specified in the Project Report is vital to ensure that the mounting system can be installed and used safely. In case the inclination of the roofs is 5 degrees or more, the PV-mounting system must always be mechanically fixed to the construction of the roof.

The calculations in the ValkPVplanner do not take into account obstacles in the near surrounding such as, for example, high buildings, cliffs and mountains. Restrictions also apply for the position of the solar mounting system on a roof. The solar panels must be installed at a certain distance from the edge of the roof as shown in the respective Project Report and the Installation Manual.

The standard warranty for pitched roof, flat roof and ground mount systems is 10 years, which can be extended under certain conditions. The guarantee provided is subject to the guarantee conditions stated in the general terms and conditions stipulated by Van der Valk Solar Systems B.V. Our terms and conditions shall apply to all our products at all times and can be found on our website:

<http://www.valksolarsystems.com>

Van der Valk Solar Systems B.V. does not accept any liability for any direct and/or indirect consequences of any act (or omission) ensuing from the information in or failure to observe the instructions provided in the Project Report and/or the Installation Manual and for possible incorrect results resulting from the use of this ValkPVplanner which was made available to you. The use of the ValkPVplanner, the derived Project Report and the Installation Manual will at all times be subject to Dutch law.

VAN DER VALK



Important

- This general installation manual does not contain project specific recommendations.
- This installation manual is not legally binding.
- No rights can be derived from this manual.
- Use this manual in combination with the ValkPVplanner project report.
- For additional information regarding cable management solutions, please refer to the ValkCableCare datasheets.
- The ValkPro+ system can be placed in the middle zone as well as the edge / corner zones of the roof.
- Side plates are optional when the system is placed in the middle zone of the roof. Side plates are mandatory when the system is placed in the edge / corner zones of the roof.
- The need for mass carriers depends on the amount of ballast needed to be placed under the panel or if side plates are used.

Table of contents:

Disclaimer	Page 1
Table of contents	Page 2
System details	
Placement conditions	Page 3
Recommended tools for installing ValkPro+	Page 4
Required materials for ValkPro+ L10 [East-West]	Page 5-7
Installing ValkPro+ L10 [East-West] (standard)	
Pre-assembly of roof carriers sets	Page 8
Placing roof carrier rows	Page 9-10
Placing ballast	Page 11-15
Mounting side plates	Page 16
Placing solar panels	Page 17-18
Mounting micro inverter clamps	Page 19
Dilatations	Page 20
Cable management	Page 21-23
Installing ValkPro+ L10 [east-West] (optional)	
Gravel roofs	Page 24
Sedum/Green roofs	Page 25
ValkPro+ as a field system	Page 26
Console fixation (ValkSolarFix)	Page 27
Ballast wing	Page 28
Extra panel support	Page 29-31

Placement conditions

In order to ensure a safe installation and use of the The ValkPro+ system, the following conditions must be respected:

- The inclination of the roof must be less than 5°.
- The roof can have a maximum height of 25 meters, in case the project has been calculated using the ValkPVplanner and is corresponding with the roof height in the project report. For installations on roofs higher than 25 meters, please contact Van der Valk Solar Systems.
- Check prior to installation if the roof membrane and/or insulation is suitable for the loads and thermal expansion of the PV-system. For example: make sure the maximum point loads of the system as shown in the ValkPVplanner project report are compatible.
- In case the mounting system is to be placed on a roof with mechanically fixed roof membrane, the risk of the membrane bulging due to wind suction needs to be mitigated. The bulging can cause unwanted lifting of the mounting system or disposition of the ballast under extreme wind suction situations. It is the responsibility of the installer to prevent bulging of the roof membrane. This can be done by adding fixation points or placing additional weight (for example tiles) on the membrane in the edge zones of the roof and around the PV-system.
- After the ValkPro+ mounting system has been placed, it is of greatest importance to check if the ballast has been placed according to the ballast plan in the project report. Ballast tiles need to be neatly stacked in order to ensure the weight is properly supported by the tile carriers, mass carriers and/or ballast wings.
- The coupled ValkPro+ system shall not be placed over a ridge or gutter. In these positions a diltation is mandatory.
- Side plates are mandatory when the system is placed in the edge / corner zones of the roof.
- In coastal areas the mounting system must be placed at a distance of at least 500 meters from open water, to prevent corrosion due to salt water spray. In case there is a building in between the open water and the roof, a distance of 250 meters can be applied.

Suitable panel dimensions:

- Length 1520 - 2320 mm
- Width 977 - 1032 mm suitable for pitch 2150 mm
977 - 1070 mm suitable for pitch 2300 mm
1071 - 1120 mm suitable for pitch 2400 mm
1121 - 1200 mm suitable for pitch 2500 mm
- Frame height 28 - 50 mm

VAN DER VALK



Required tools for installing ValkPro+



Cordless drill

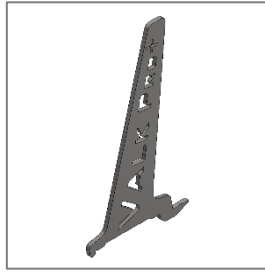

Disassembly key for feet
743000

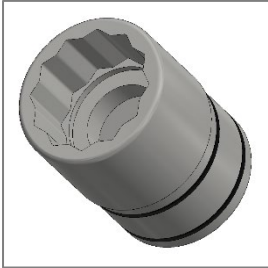

Socket 13 mm
Wrench 13 mm



Adjustable alignment set for
roof carriers
743220

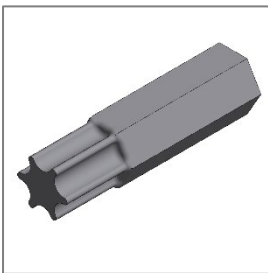

Torx bit T-30
(789530)

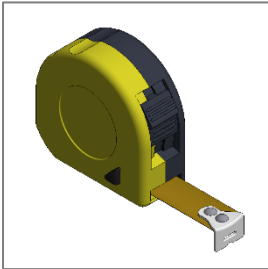

Measuring tape

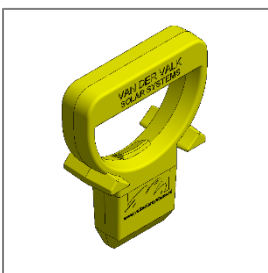

Alignment key for roof carriers
739010

Basic materials for installing ValkPro+ L10 [East-West]

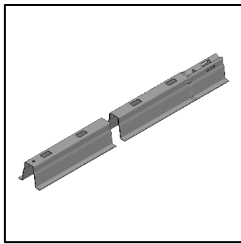

Roof carrier profile

741802300
741802400
741802500

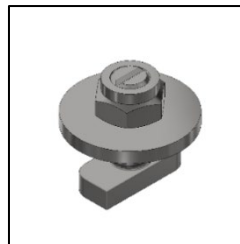

Coupling set

774221

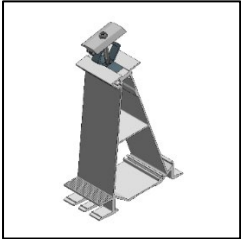

Back foot middle

724650

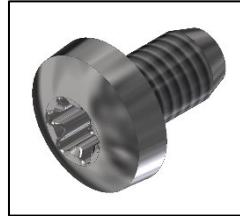

Thread forming bolt M6x10 mm
for fixation of side and back
plates

773310

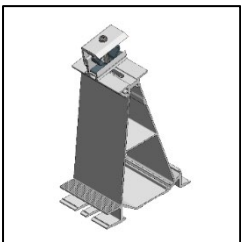

Back foot side

724651

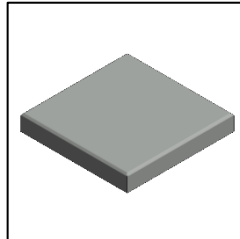

Concrete tile 9 kg (300 x 300 x 45
mm)

7506303045

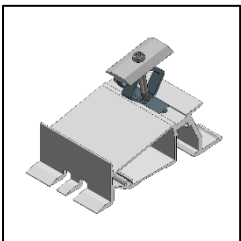

Front foot middle

724660

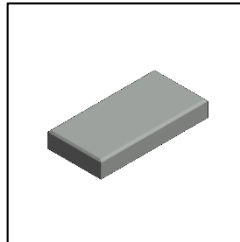

Concrete tile 4,5 kg (300 x 150 x 45
mm)

7506301545

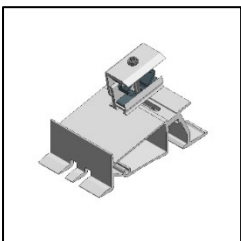

Front foot side

724661

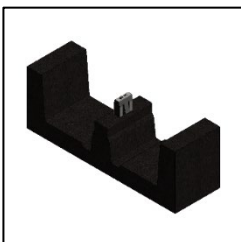

Tile carrier

729622 - for bitumen / TPO / EPDM roof
729623 - for PVC roof

For the 'optional' materials, see next page.

VAN DER VALK



Optional materials:

The optional materials can be used to optimize the system to specific situations and wishes.

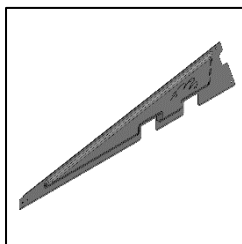

Side plate (can be used for left and right side of the system)

742540

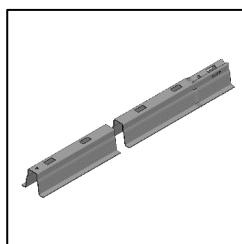

Roof carrier for half-peak
(741801200)

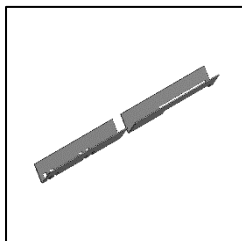

Mass carrier

742550 - [for panel length 1520-1720 mm]
742553 - [for panel length 1720-1920 mm]
742555 - [for panel length 1920-2120 mm]
742556 - [for panel length 2120-2320 mm]

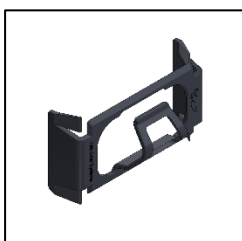

Cable clamp for feet
732011

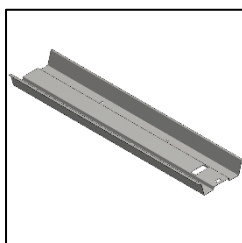

Ballast tray

742610 [for panel length 1520-1720 mm]
742612 [for panel length 1720-1920 mm]
742615 [for panel length 1920-2120 mm]
742618 [for panel length 2120-2320 mm]

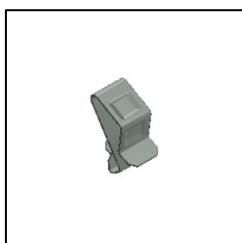

Cable clamp for fixation to panel frame
732001

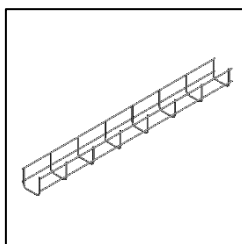

Cable basket 50 x 60 mm, length 3000 mm
(76010050603000)

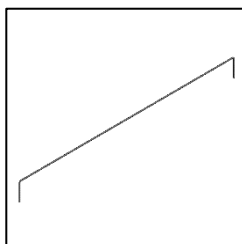

Dilatation wire
732020

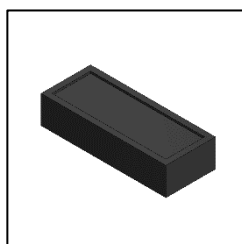

Elevation block for gravel roofs
729627

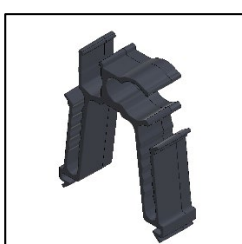

Multi-wire / connector clip for roof carrier
732012

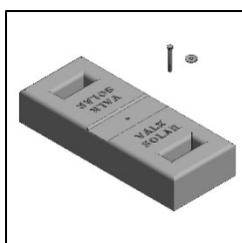

Mass block (750520)
+
Stainless steel bolt M8 x 65 mm (774065)

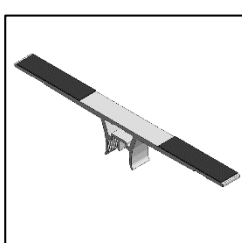

Ballast wing
725150

VAN DER VALK



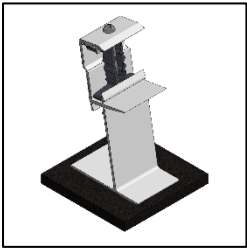

Panel support - Front foot

724710

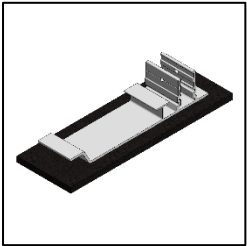

Panel support - Base plate small

724720

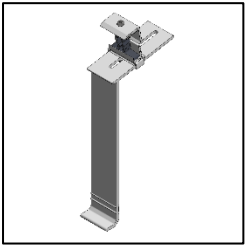

Panel support - Upright

724730

Pre-assembly of roof carriers sets

A fast and convenient way of working can be best achieved by mounting the feet and tile carriers on the roof carriers prior to placing them on the roof. This method can save a lot of time. The aluminium feet should be placed in the position where the letter "L" is visible on top of the roof carrier. The rubber tile carriers are placed in the second rectangular hole in front of the aluminium back foot.

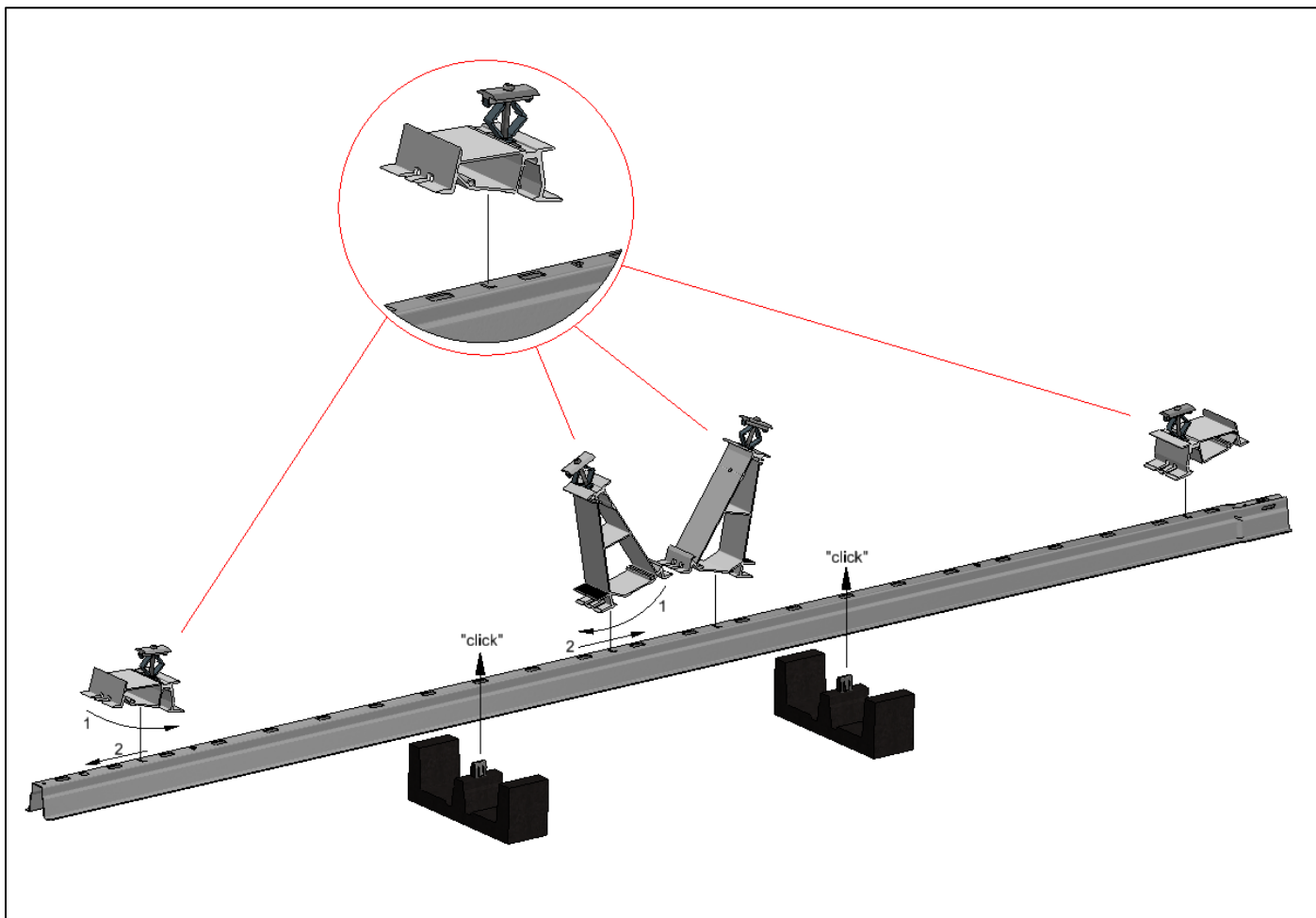

Side view

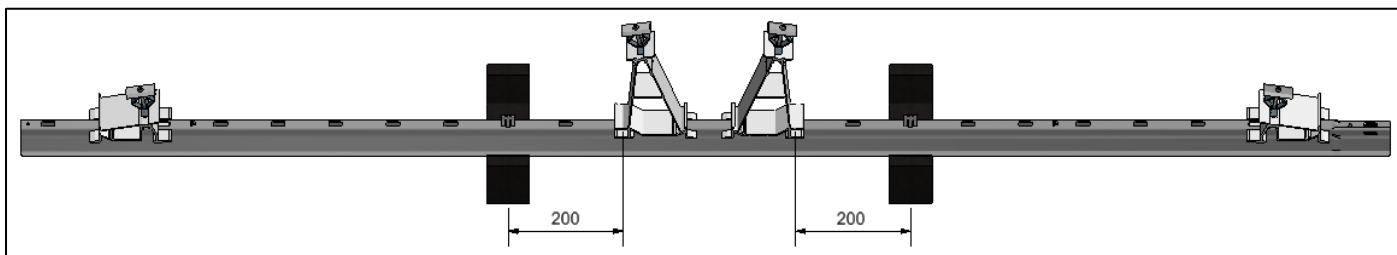

Alignment of roof carriers

Place the roof carriers on the roof in the desired layout or starting point. Connect the roof carriers by placing the end of the first roof carrier over the reduced end of the next roof carrier. The roof carriers are then fastened with the coupling set. (see 1.3)

The center-to-center distance between the roof carrier rows depends on the panel size. The following formula must be applied: panel size + 10 mm. For fast and easy alignment of the roof carriers, we advise to use the adjustable alignment tool (art. 743220).

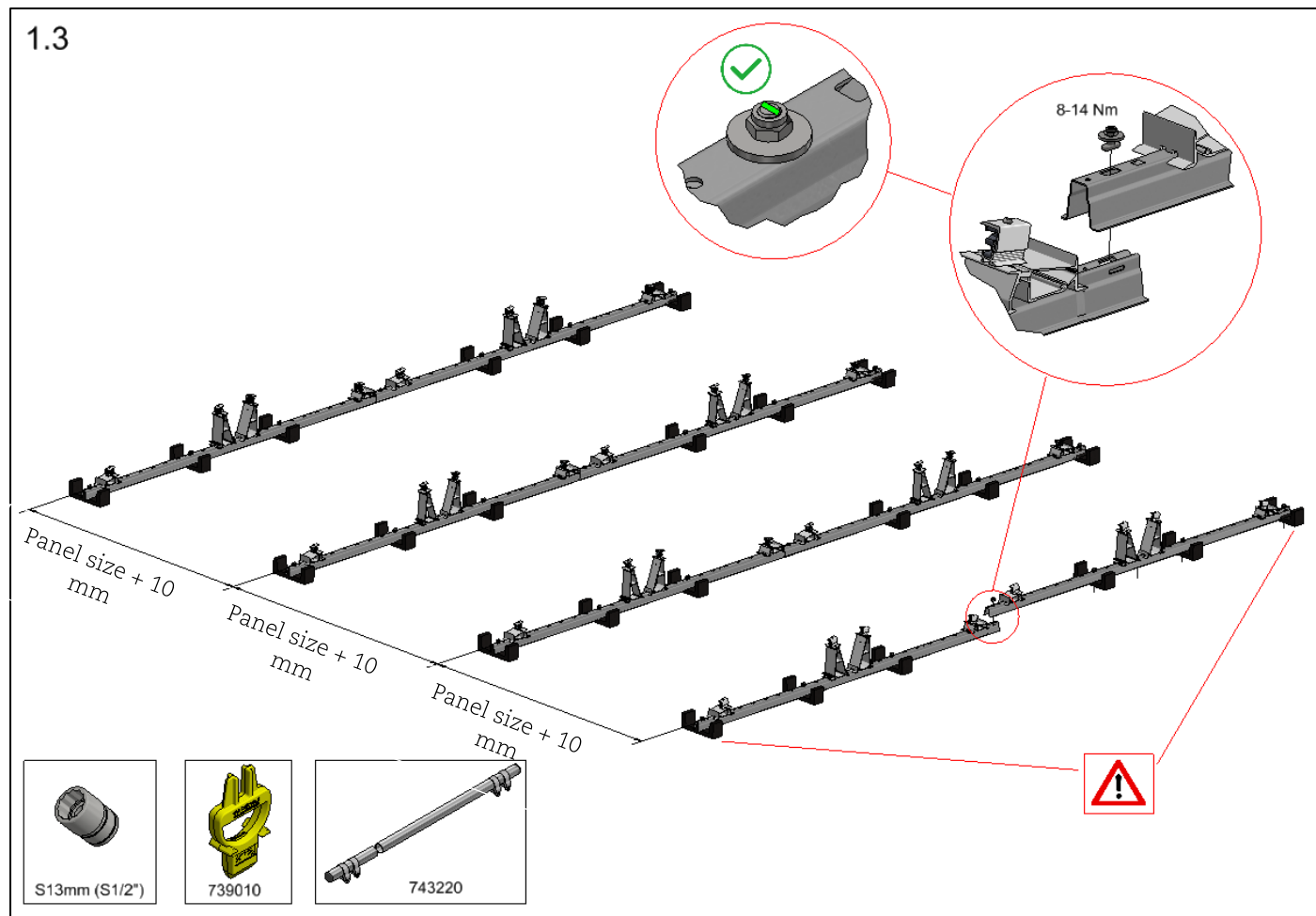

In the first and last oblong-hole of the roof carrier row (incl. reduced part) an extra rubber tile carrier must always be placed.

Dilatations

The coupled system has to be dilatated after certain measurements, this needs to be done because of the thermal expansion/contraction. For the South-North direction this is 60 meters, for the East-West direction this is 30 meters.

VAN DER VALK



Tools for alignment of roof carriers

Aligning the roof carriers can be done quick and easy using the following tools:

Alignment lip roof carrier

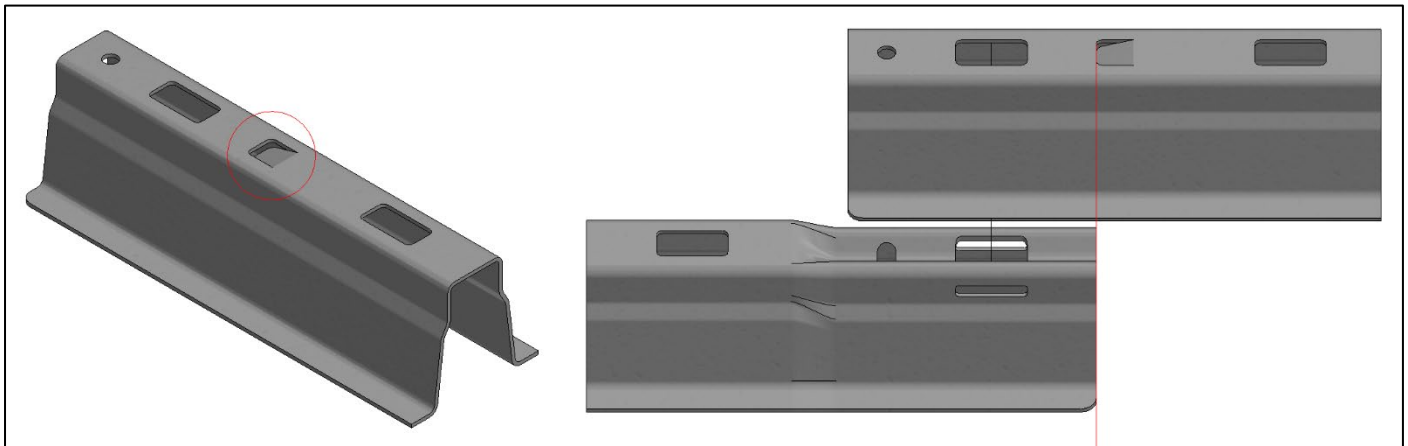

The smooth side of each roof carrier is provided with a lip which can be used when aligning / coupling the roof carriers. The swaged end of the roof carrier can be placed against the lip, this makes sure the roof carriers are always aligned properly.

Alignment key ValkPro+ (art. 739010)

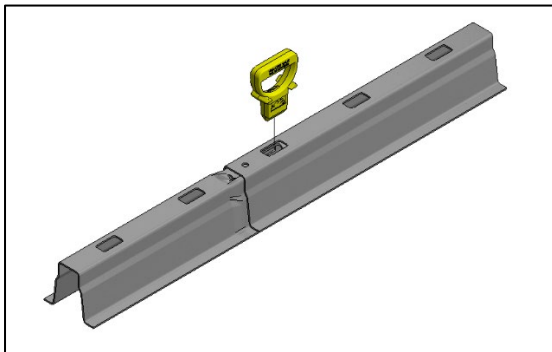

The alignment key can be used to align the overlapping oblong hole of the roof carriers.

Alignment set ValkPro+ (art. 743220)

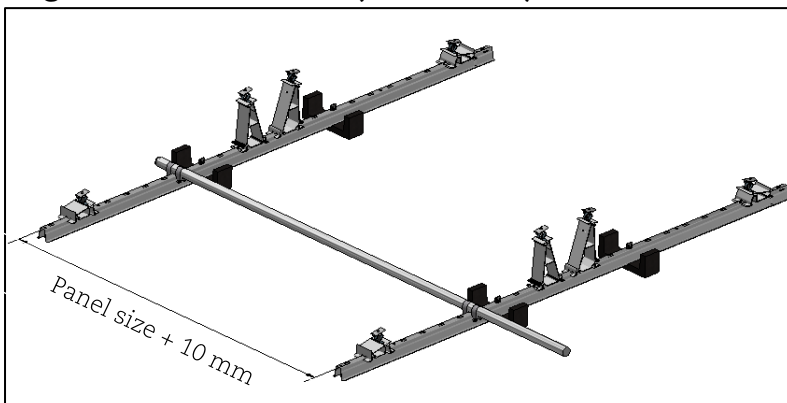

The alignment set can be used to make sure the roof carrier rows are placed at the correct pitch beside each other.

VAN DER VALK



Placing ballast

The ballast can be placed on the rubber tile carriers or on the mass carriers (only when necessary). Check the ValkPVplanner project report for the required ballast weight per panel.

2.1

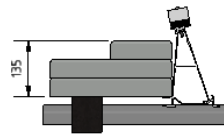
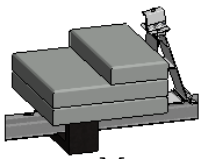
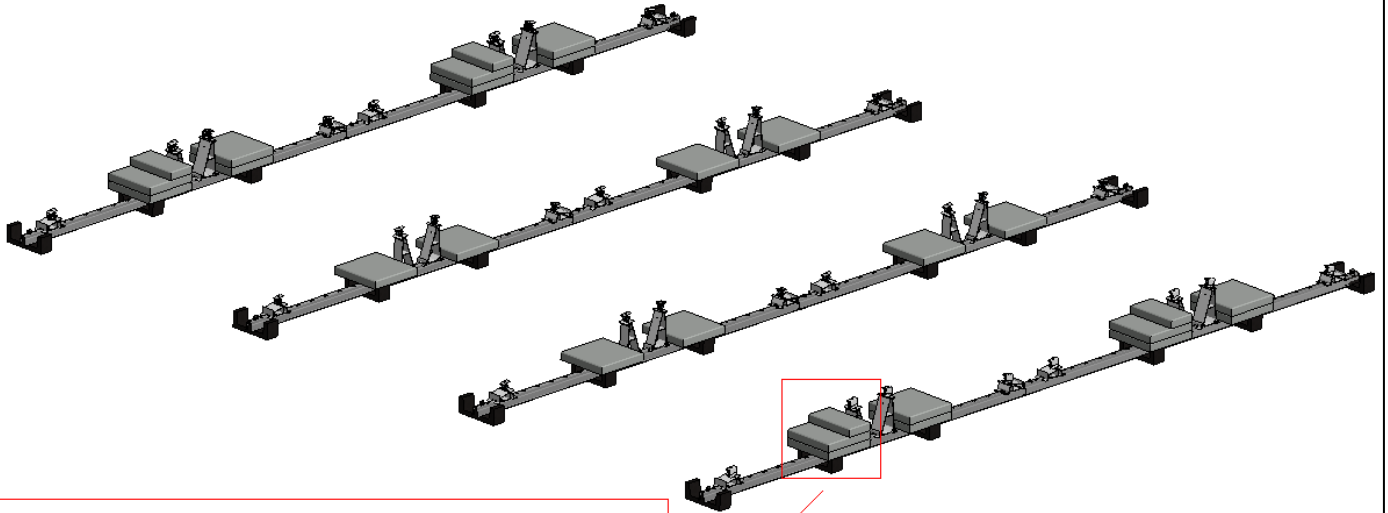

Max. no. of tiles on rubber tile carriers: 2,5 tiles (22,5 kg)

Mass carriers

In case the required ballast is more than 4,5 tiles or if the ballast cannot be placed due to side plates, mass carriers are required. The mass carriers are placed on both sides of the rubber tile carrier. The mass carriers provide the support for the tiles (see image 2.2).

2.2

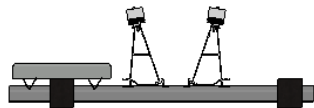
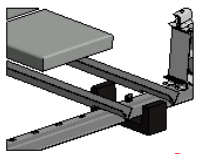
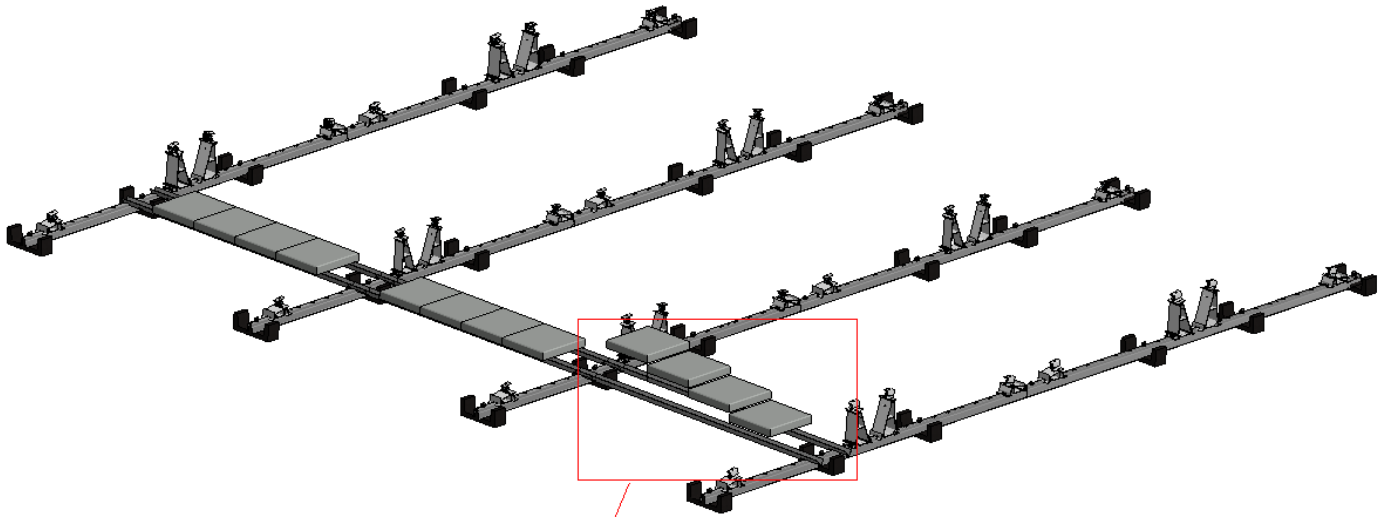

Max. no. of tiles on mass carriers: 10 tiles
(90 kg)

Ballast trays

In case gravel (coming from the roof on which the system is placed) or pavers are used for ballast, ballast trays can be applied. The ballast trays are placed over the roof carriers. The slots in the ballast trays on one side will fit the rubber tile carriers so that the ballast trays cannot move. The other side of the ballast tray can be placed in the next ballast tray.

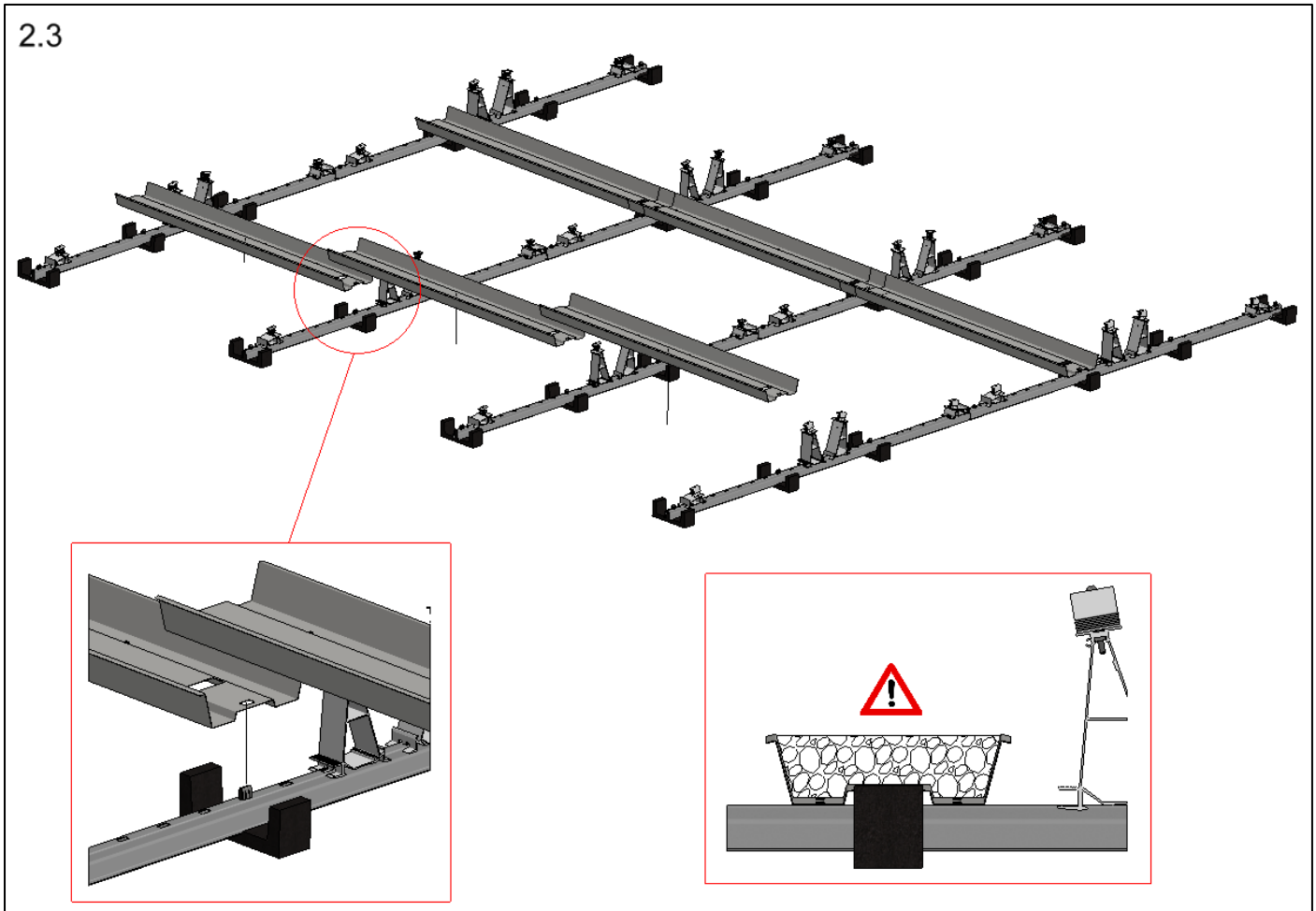

The max load per tray in case it is filled to the maximum with gravel:

Art. 742610 (1780 mm) – Max. 36,6 kg

Art. 742612 (1980 mm) – Max. 40,9 kg

Art. 742615 (2180 mm) – Max. 46,4 kg

Art. 742618 (2380 mm) – Max. 50,7 kg

In the calculation above a gravel density of 1500 kg/m³ is used.

VAN DER VALK



Distributing ballast

The ballast is placed according to the ballast plan in the project report. The project report indicates the required ballast per panel for a South system and per peak for East-West system. Without mass carriers the ballast is to be divided over the ballast points under the individual panel. The next image shows how the ballast should be divided over the different ballast points.

PLEASE NOTE! Image below is an example.

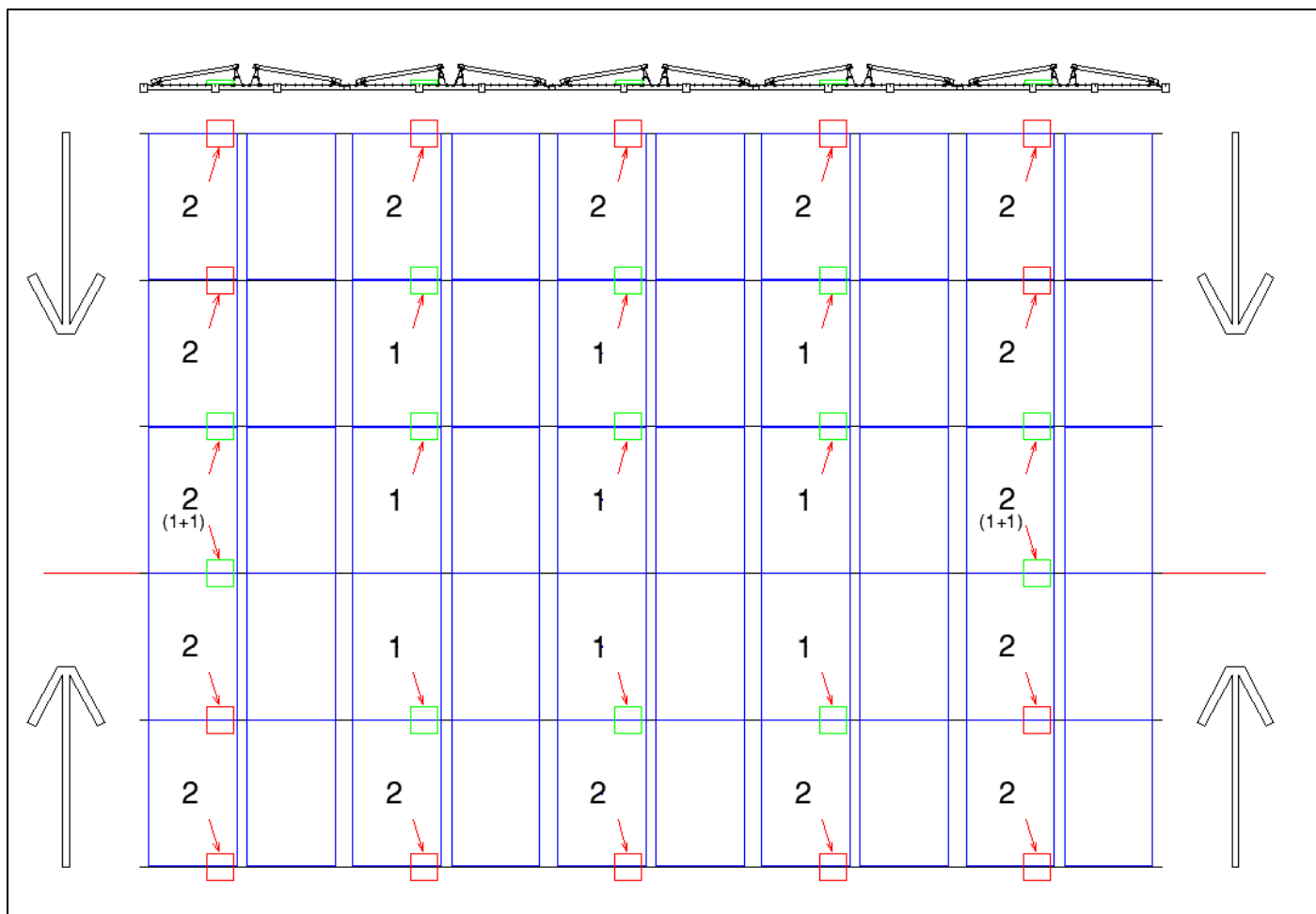

The required number of tiles is indicated per panel or peak (same as the project report). The ballast is always placed starting from the outside toward the centre of the system. Therefore the middle row of the system doesn't have any ballast (see red line). If possible there may be ballast placed on those foundation points as well.

VAN DER VALK



When using the rubber pressure dividers, it is important that these are placed in the correct positions. The numbers in the image below represent the order of the pressure dividers when using 1, 2 or 3 pieces. For more information, please refer to the datasheet.

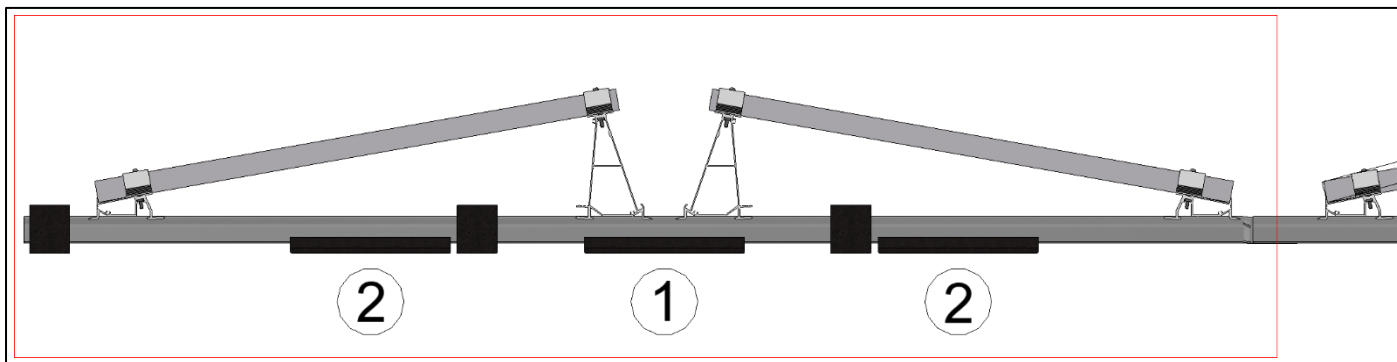

Mounting side plates

The use of side plates is optional, in case the mounting system is placed in the middle zone of the roof. Side plates are mandatory in case the following is applicable:

- The mounting system is partially placed in the edge / corner zones of the roof.
- Roof height is 25m or higher

Each side plate is fixed to the sides of the aluminium feet using three thread forming bolts M6 x 10 mm. (see image 3.1)

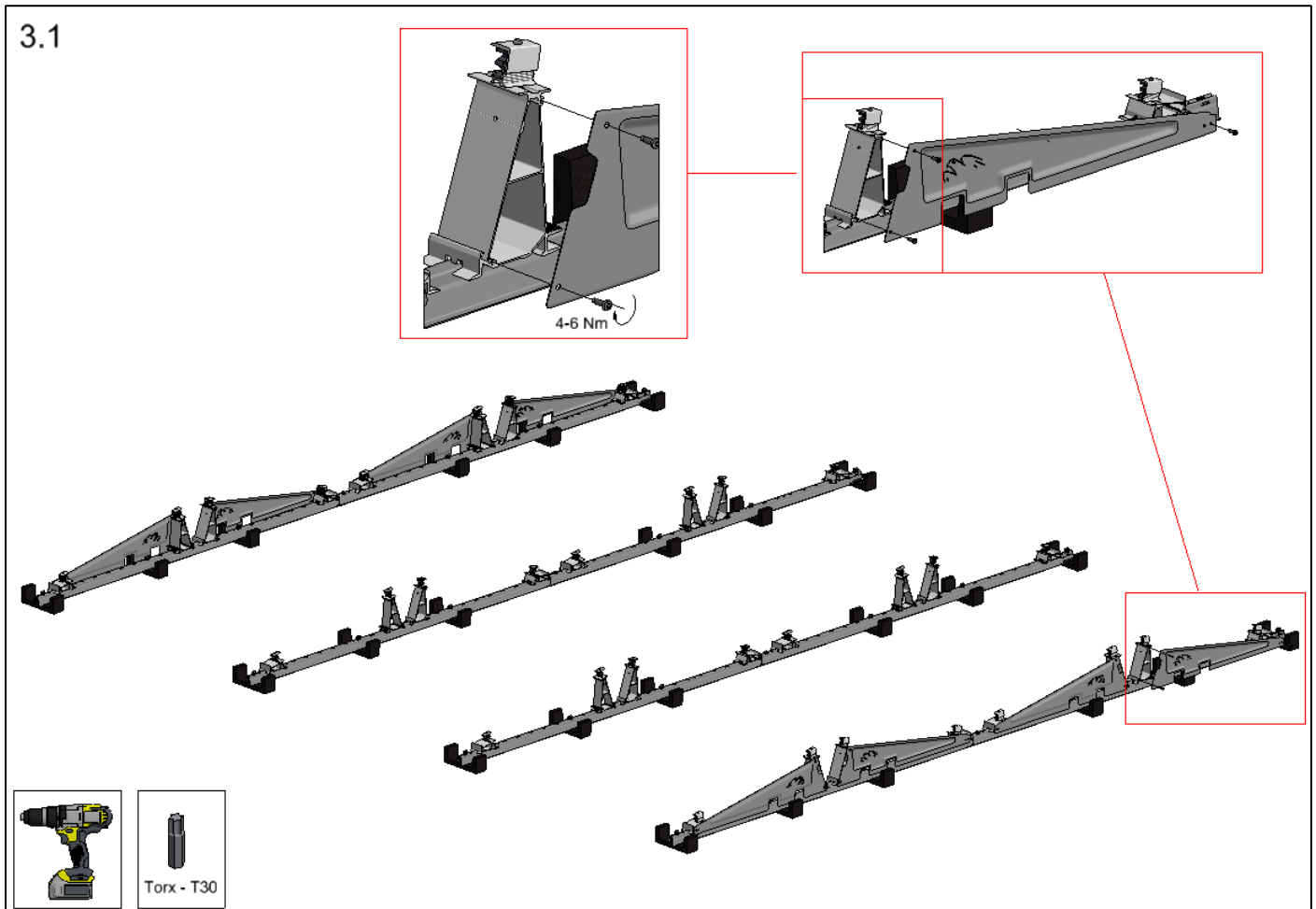

Placing PV-panels

Place the PV-panels under the clamps and make sure ALL the panel clamps are securely fastened.

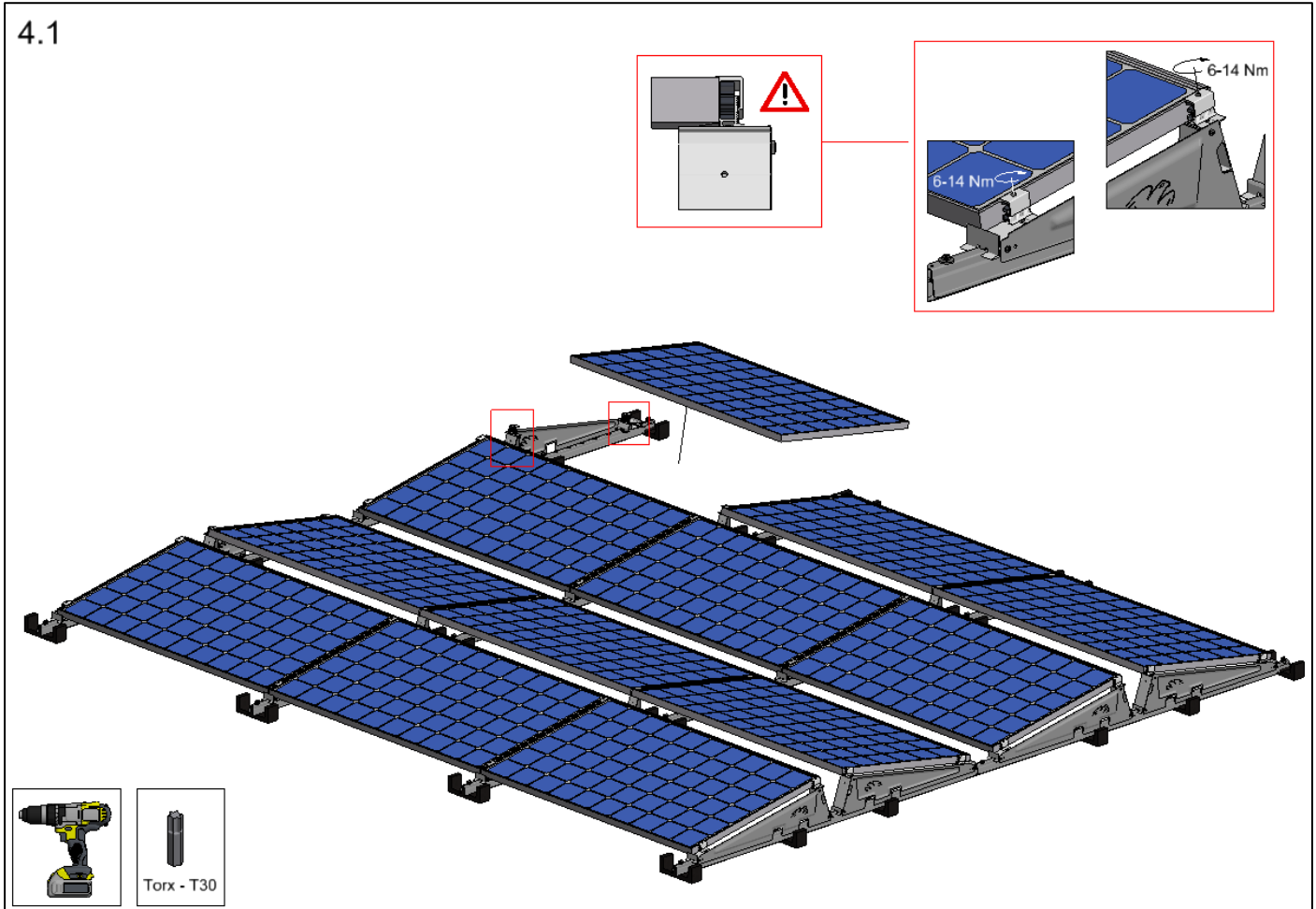

Make sure the end clamps are placed in the correct height slot, corresponding with the panel frame thickness, before they are fastened. The clamps must have an overlap of at least 6,3 mm with each panel frame, in order to ensure full clamping force.

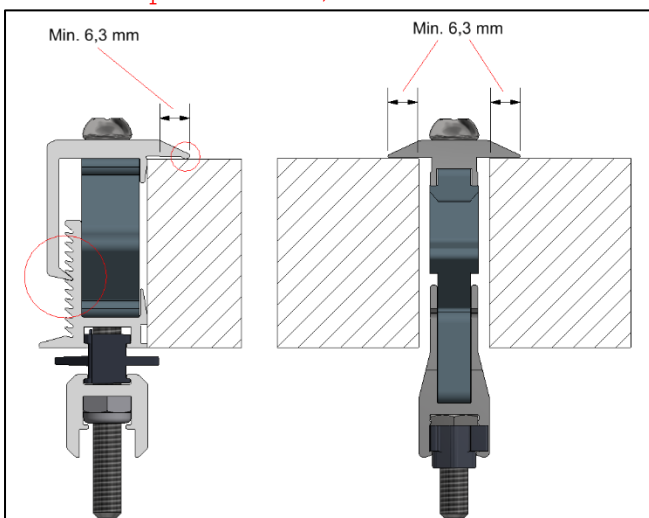

VAN DER VALK



The front foot is designed with an upstanding edge, which makes it easy to align the PV-panels, when the frames are placed against this edge. This is not mandatory however. In case it is not possible to place the panels against the edge, it is ok as long as the side of the frame is still positioned in range X. The ValkPro+ system will then still apply enough clamping force on the panels.

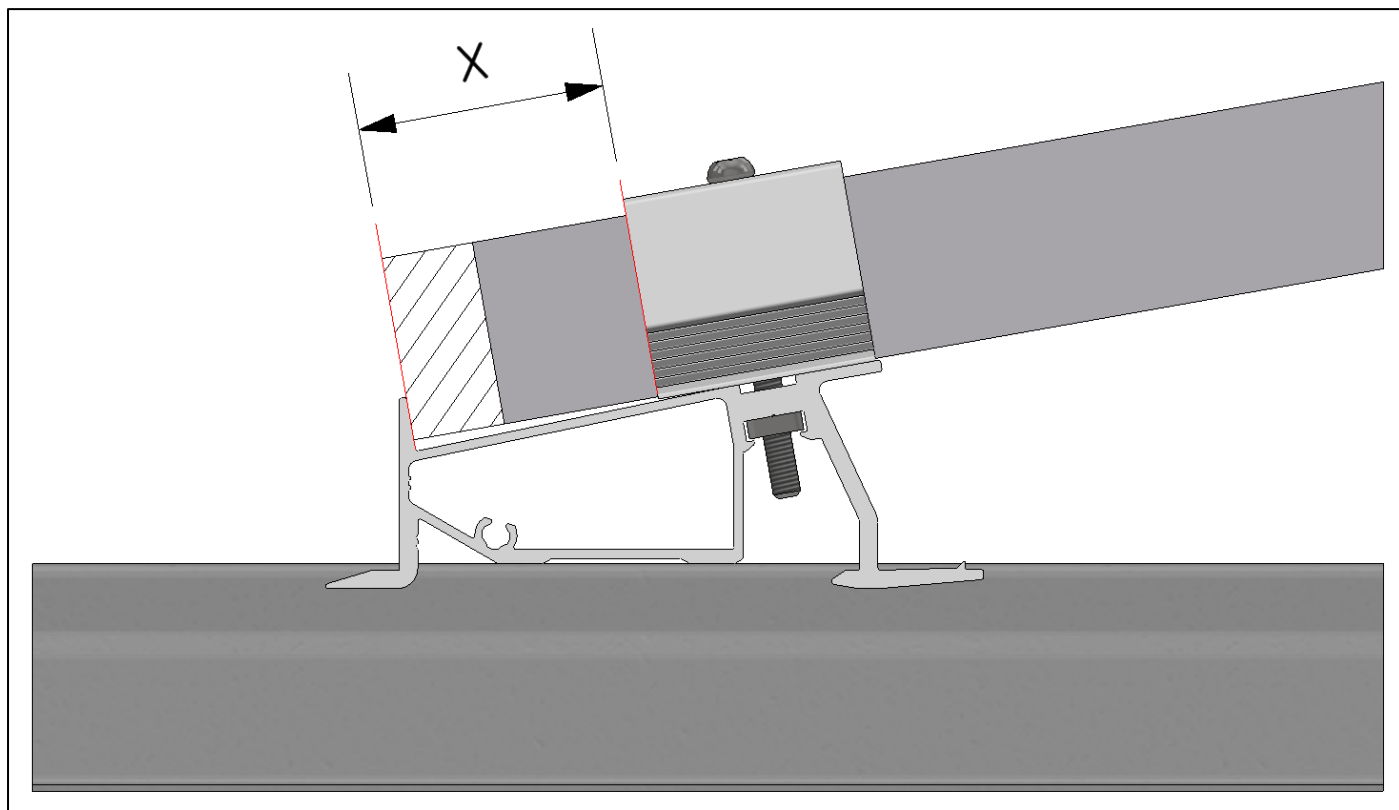

Mounting micro-invertors

Micro-invertors can be mounted on the roof carrier using a coupling set (Art. 774221).

5.1

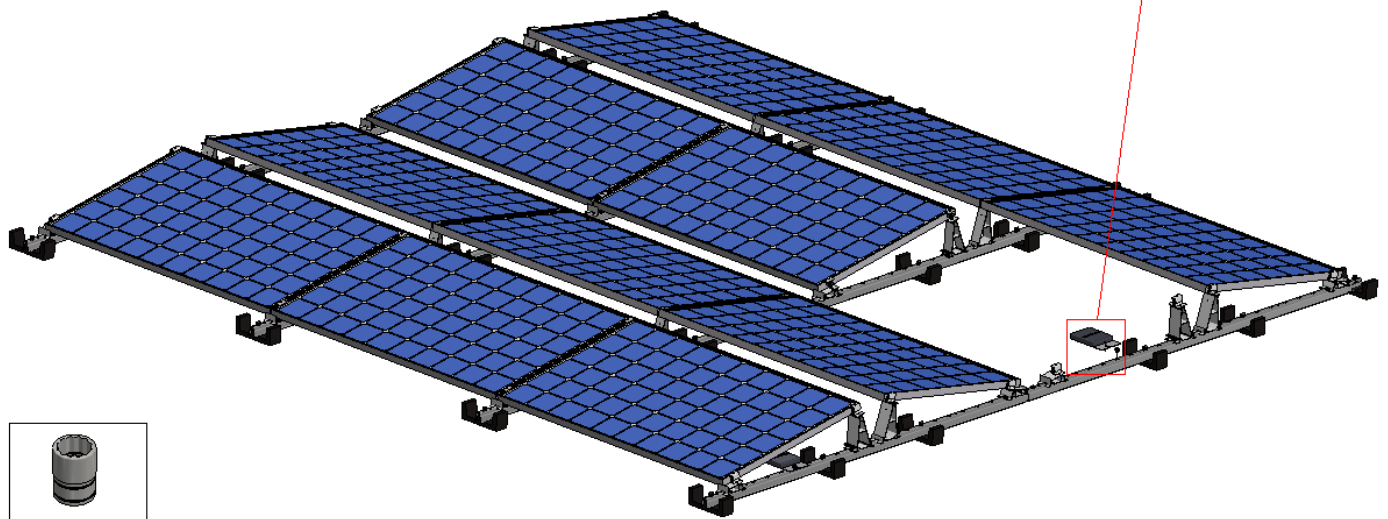
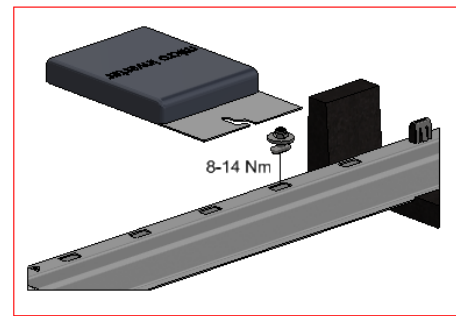

VAN DER VALK



Dilatations

The ValkPro+ system has certain measurements that may not be exceeded due to thermal expansion/contraction. If these measurements are bigger than allowed the system must be dilated. The required distance for the dilatations is shown in image 6.1.

Once the system has a dilation the system is now seen as 2 separate systems. If the dilatations are not too big some parts of the system can still be calculated as 'shielded panels'. (shielded panels have less ballast than the exposed panels)

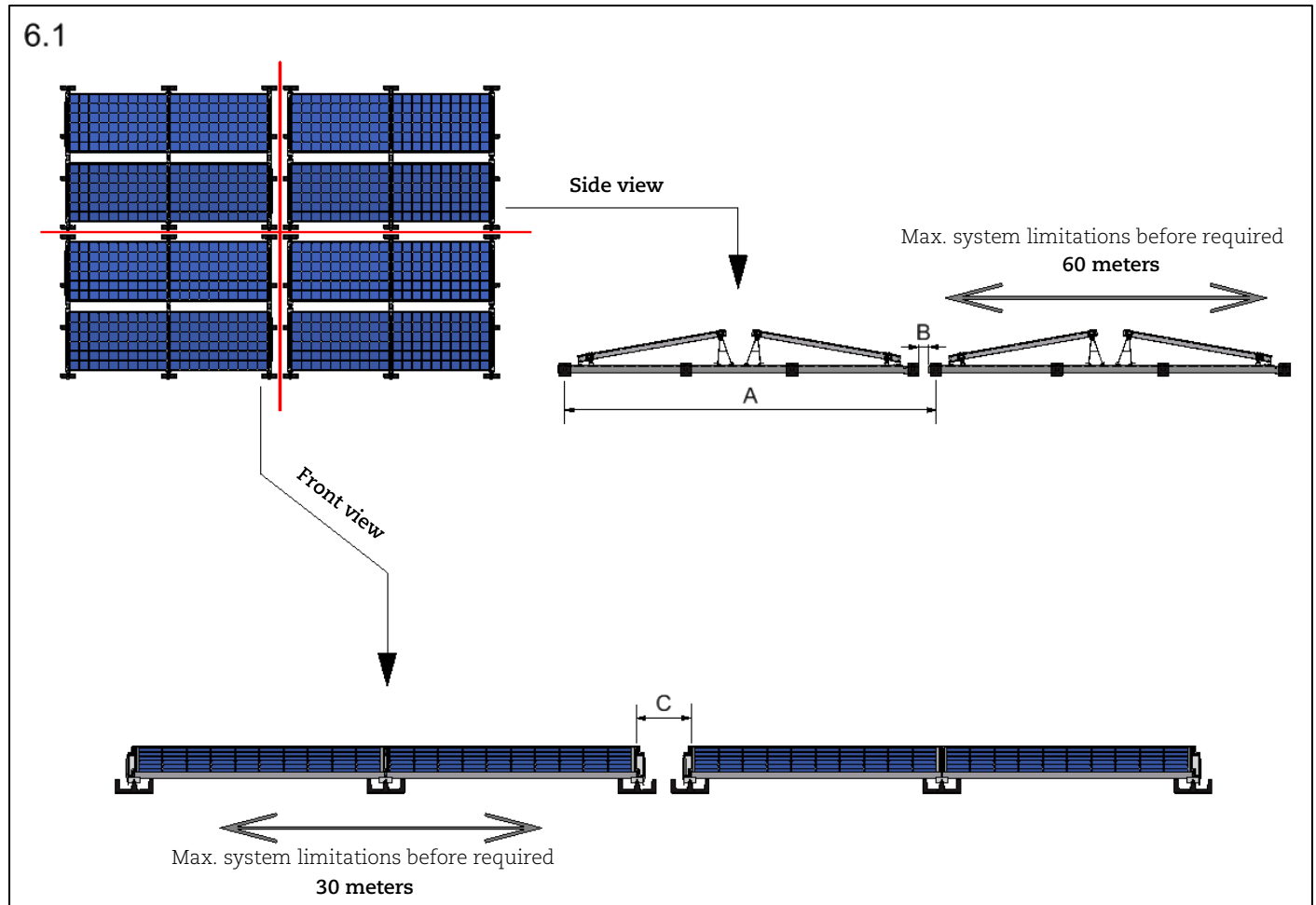

The dimensions below refer to the distance limitations of the dilatation for the outer panels of the system to be 'shielded'. In case these distances are longer, the outer panels of the system, need to be seen as 'exposed', which means more ballast needs to be placed, compared to 'shielded' panels.

Dimension A:

For pitch 2150mm - [min. 2270 mm and max. 2600 mm]

For pitch 2300mm - [min. 2420 mm and max. 2600 mm]

For pitch 2400mm - [min. 2520 mm and max. 2600 mm]

For pitch 2500mm or larger, the outer PV-panels are automatically 'exposed'.

Dimension B:

For pitch 2150mm - [min. 37 mm and max. 367 mm]

For pitch 2300mm - [min. 37 mm and max. 217 mm]

For pitch 2400mm - [min. 37 mm and max. 117 mm]

For pitch 2500mm or larger, the outer PV-panels are automatically 'exposed'.

Dimension C (distance between the frames of the PV-panels):

Min. 350 mm and max. 500 mm

VAN DER VALK



Cable management

The ValkPro+ system offers various options to handle the electrical cables and connectors in a safe and neat way. The first option is to use plastic cable clamps (Art. 732011) that are mounted on the aluminium back feet. The cable clamps are simply “clicked” on the aluminium feet and the cable can be placed (see image 7.1)

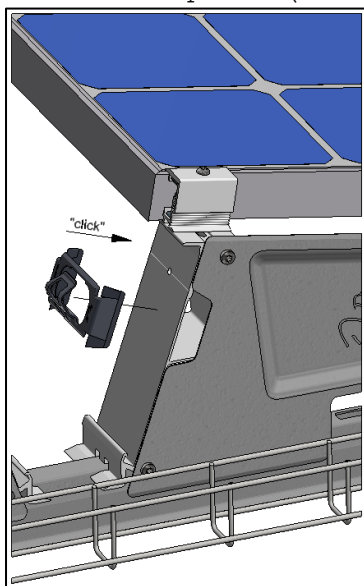

The cable clamp provides space for:

- 5 cables - Ø6mm
- 4 cables - Ø7mm
- 3 cables - Ø9mm

Multi-cable and connector clip (Art. 732012)

This clip can be placed over the roof carrier in any desired location. It has multiple options to hold various MC4 connectors and cables:

- 2 x MC4 connector holder
- 2 x Cable holder Ø12 mm (DC/AC)
- 12 x Cable holder Ø6 mm

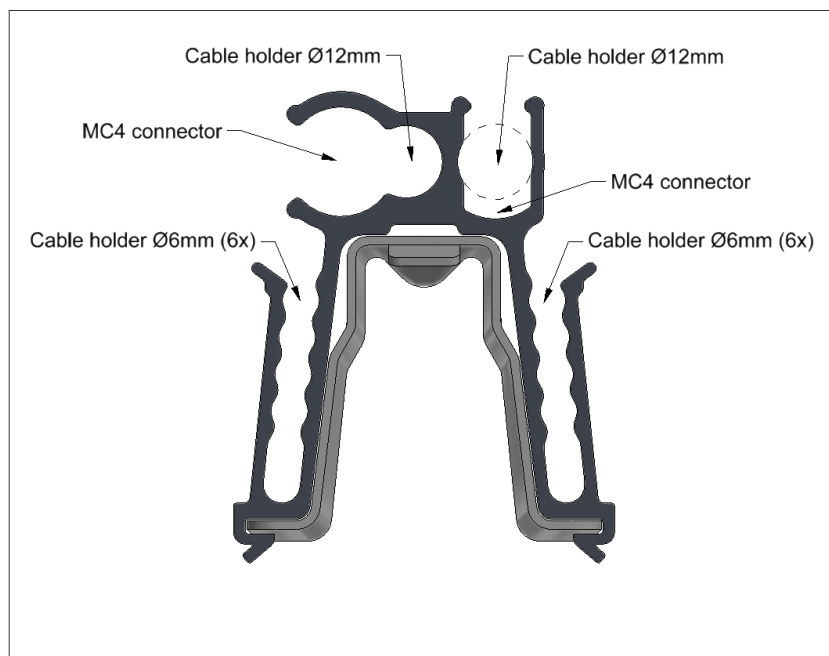
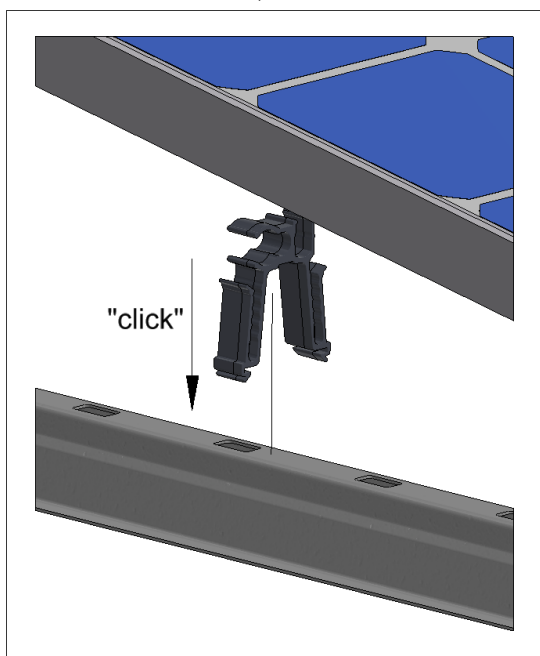

Cable baskets can be nicely integrated in the ValkPro+ system. ValkCableCare cable baskets with dimensions 50 x 60 mm fit on both sides of the roof carrier and can be placed in the spaces of the tile carriers (see image 7.2).

Please note: in case mass carriers are used, it is not possible to place the 50 x 60 mm cable baskets in the inside position (under the PV-panel) next to the roof carrier.

7.2

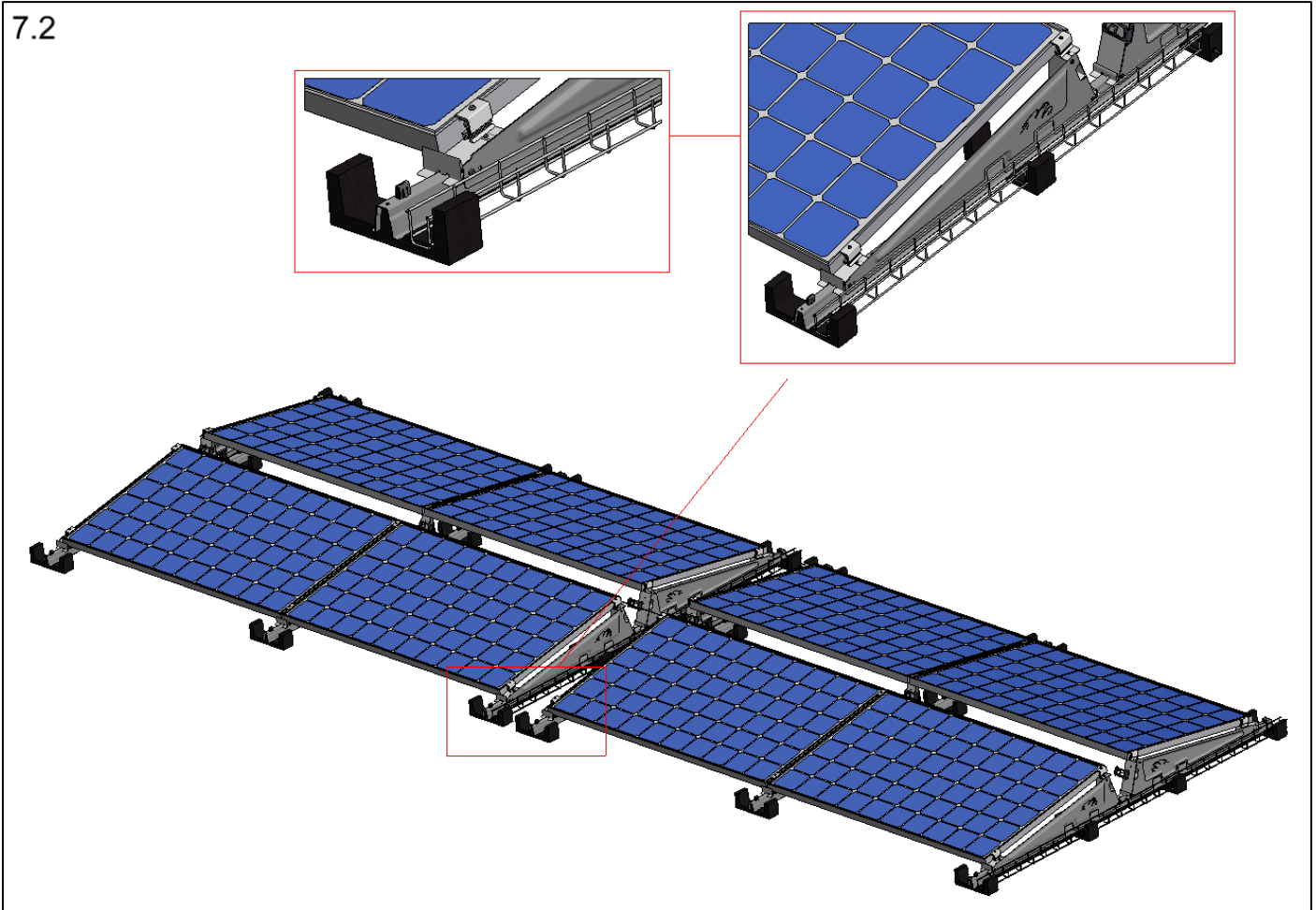

In positions where there is a dilatation in the system, a metal dilatation wire (Art. 732020) can be used. This wire can be placed in the cable clamps and the length can absorb the thermal expansion of the coupled system. The electrical cables can be fixed to the wire using tie-wraps. This keeps the cables free from the roof surface.

7.3

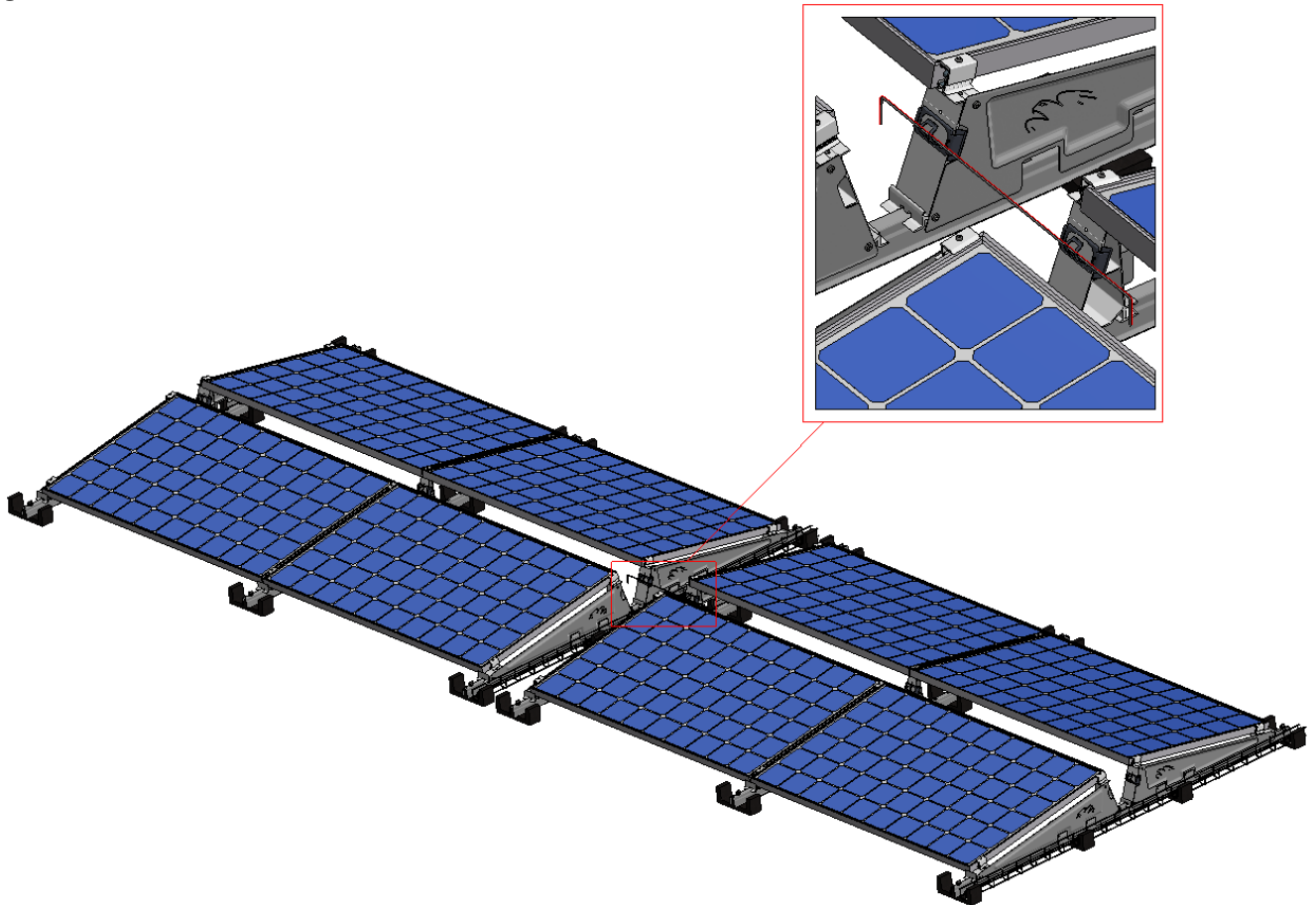

Special surfaces

The ValkPro+ system can be placed on a range of different surfaces, besides the “normal” roof coverings. Each surface requires a different foundation method. In this section of the manual the foundation methods for each surface are shown.

Gravel roofs:

In case the roof is covered with gravel the system can be elevated using rubber elevation blocks (Art. 729627). It is important to ensure the distance between the gravel and the lowest part of the PV-panel is always between 95,5 - 115,5 mm.

8.1

Min. 95,5 mm - Max. 115,5 mm

Gravel roof

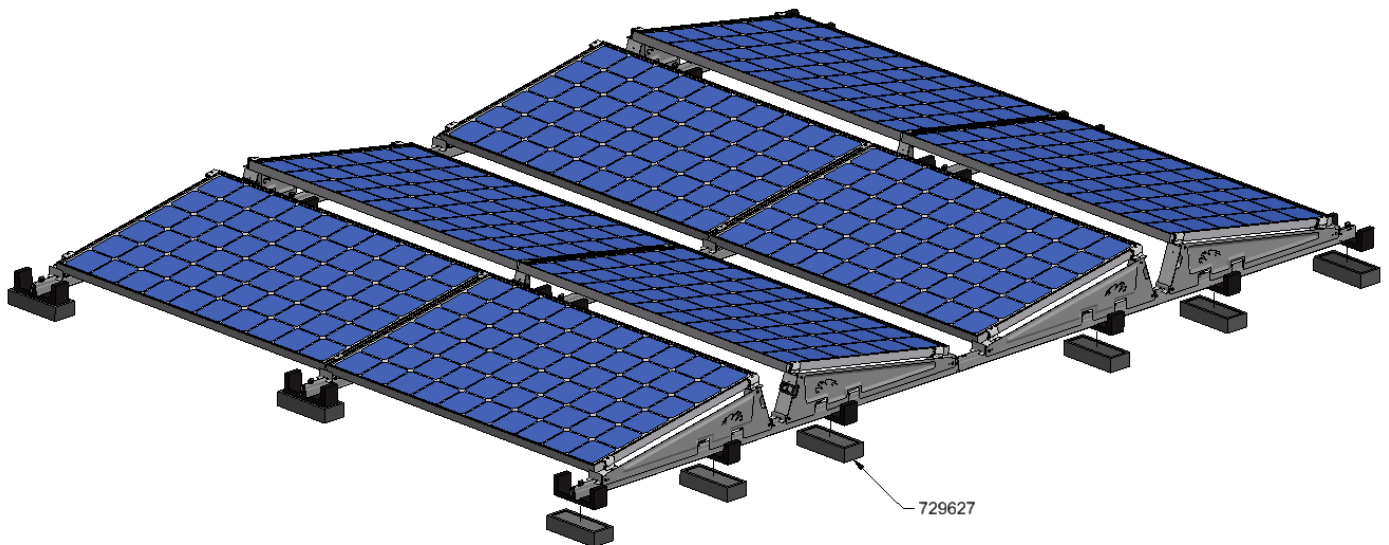
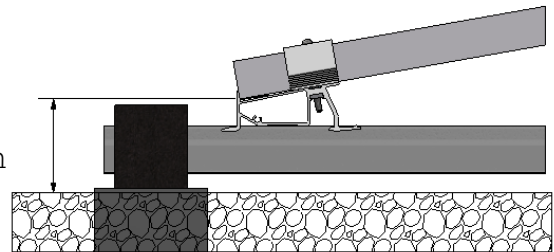

VAN DER VALK



Sedum / green roofs:

For sedum / green roofs the advice is to first place tiles (Art. 7506303045) in the sedum, to support the tile carriers of the ValkPro+ system. The tiles will better distribute the point loads and prevent the system from sinking into the vegetation. It is important to ensure the distance between the sedum and the lowest part of the PV-panel is always between 95,5 - 115,5 mm.

8.2

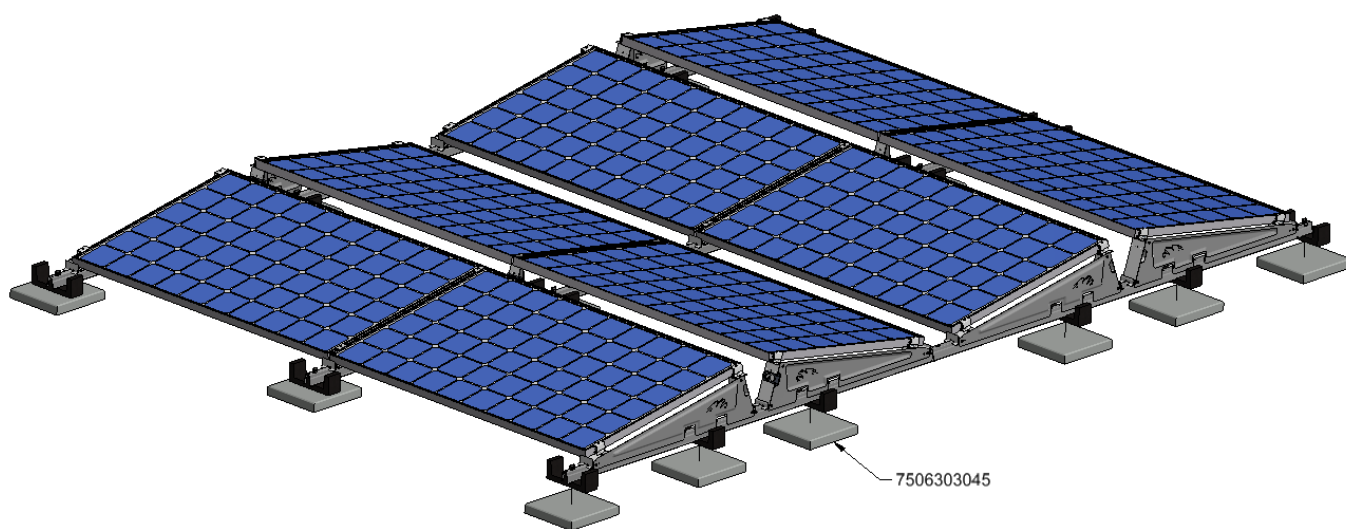
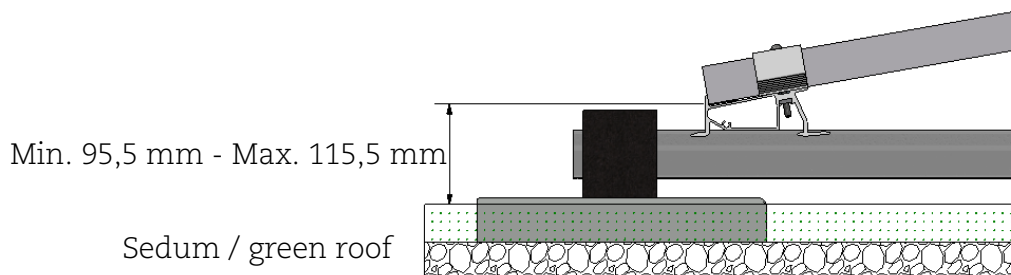

ValkPro+ as a field system:

The Valkpro+ system can be placed on the ground as a field system. For this method the system is mounted on top of concrete mass blocks (Art. 750520). These mass blocks are fixed to the roof carriers with a stainless steel M8 x 65 mm bolt and washer (Art. 774065 + 774009).

8.3

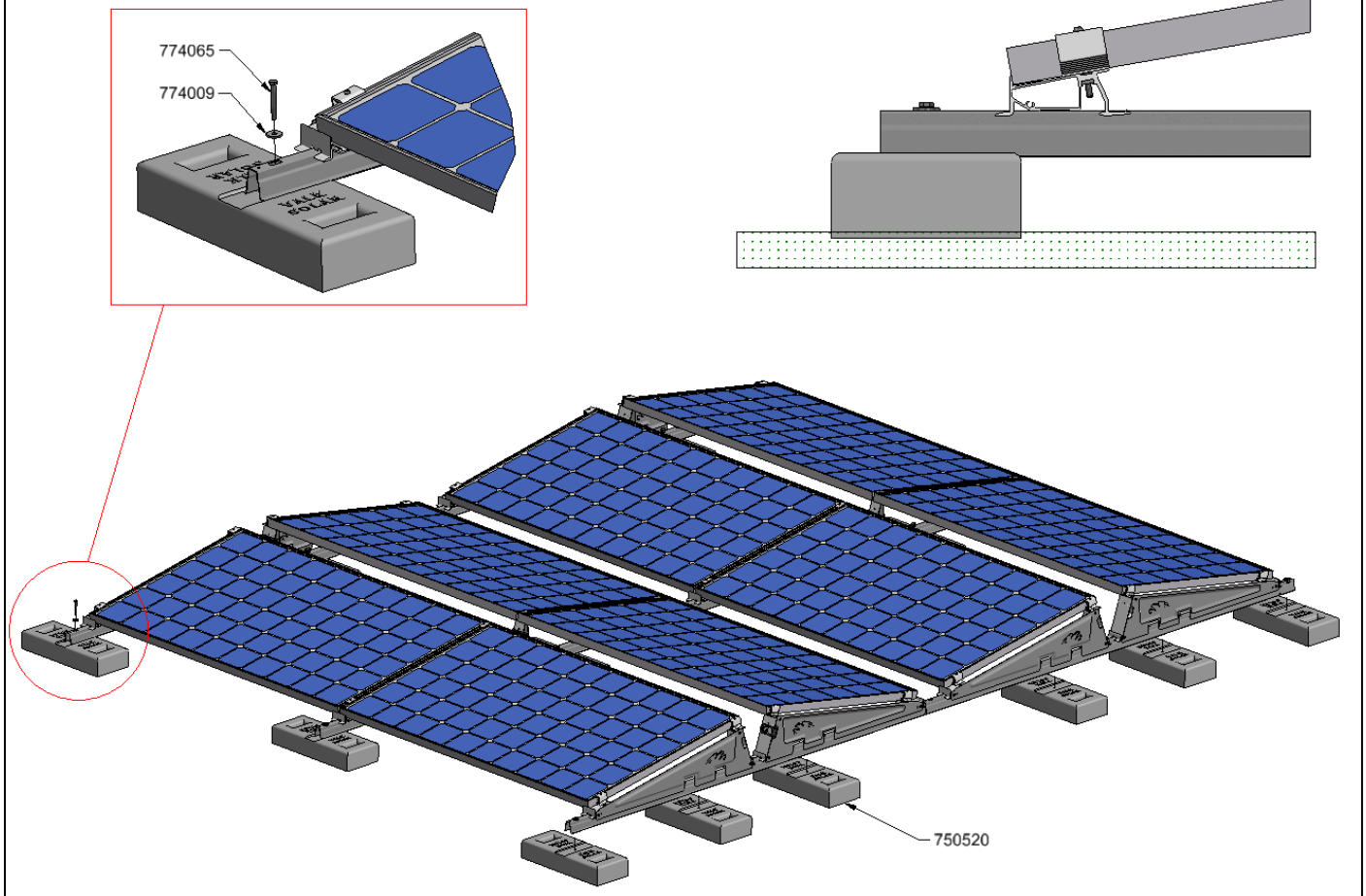

ValkPro+ as a field system cannot be calculated with the ValkPVplanner software. Please contact Van der Valk Solar Systems to calculate your project.

ValkSolarFix:

The ValkPro+ system can be mechanically fixed to the roof. This can be done with the ValkSolarFix consoles. The consoles with special height of 20mm can be fixed to the roof with:

- Toggle anchor
- Concrete anchor
- Roof screw for fixation in wood
- Roof screw for fixation in steel
- Roof screw for fixation in aerated concrete

For the detailed mounting of a specific ValkSolarFix anchor, please refer to the manuals that can be downloaded from our website: <http://www.valksolarsystems.com>.

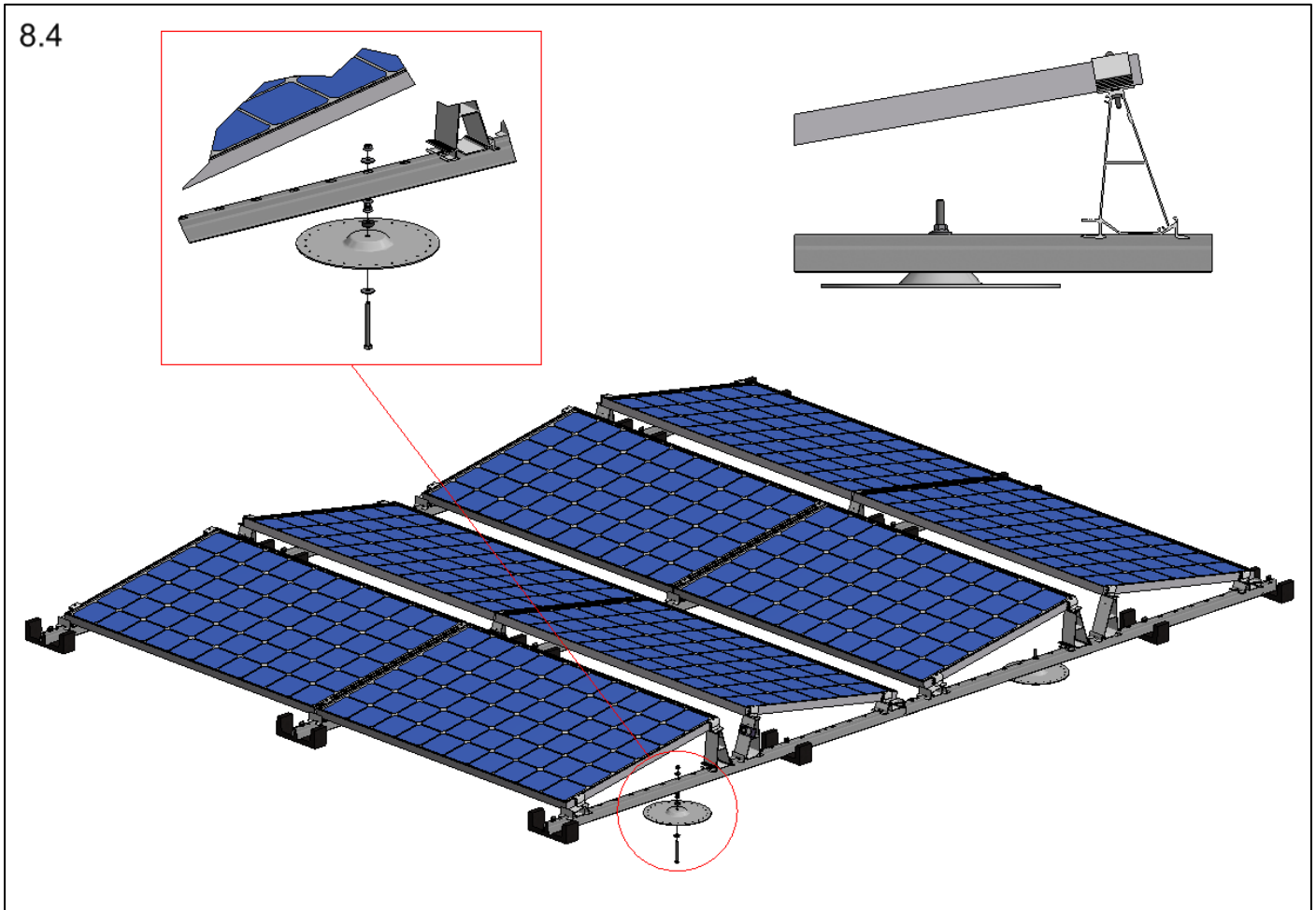

Ballast wings:

When non-standard or larger tile sizes are used for ballast and mass carriers are not ideal, ballast wings can offer a solution. In combination with the rubber tile carriers the ballast wings can provide additional support for the tiles. On the rubber tile carrier with ballast wings 3,5 standard tiles can be placed.

The ballast wing is mounted by placing it over the roof carrier above a free hole and push it downwards.

8.5

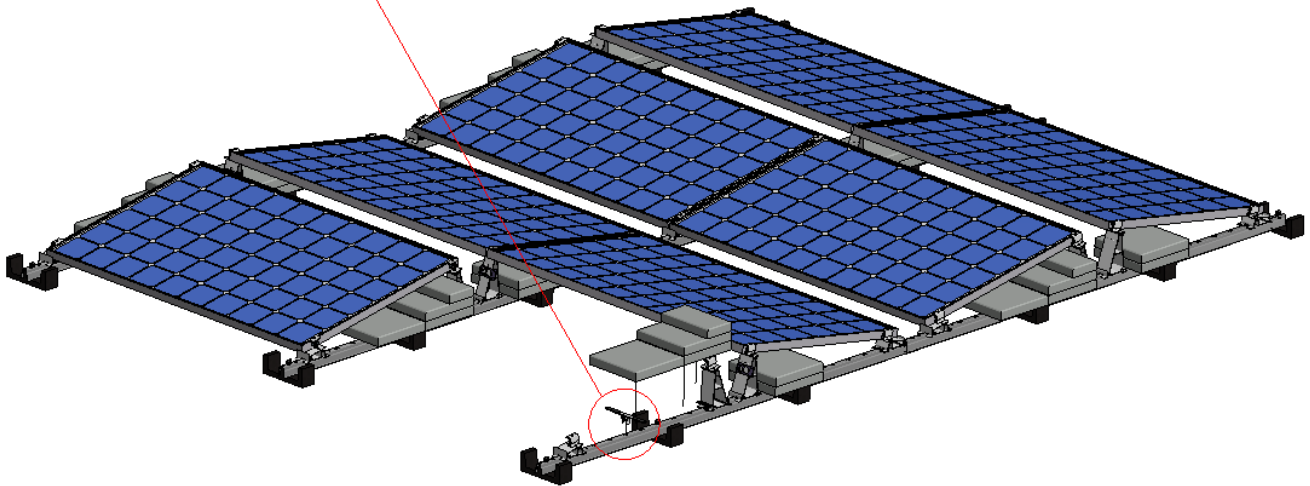
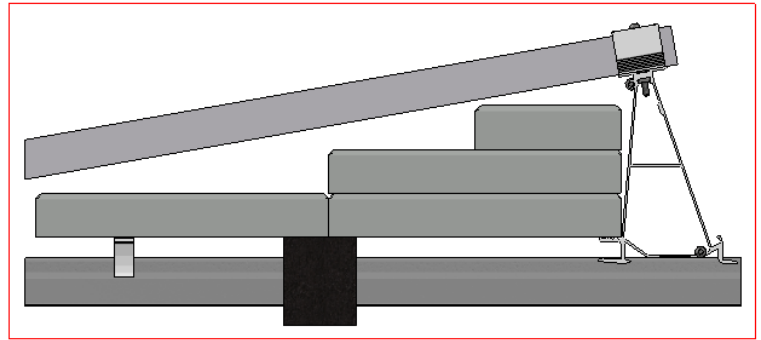
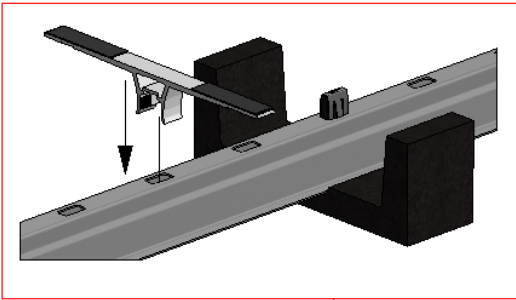

VAN DER VALK



Extra panel support

For applications in areas with a high snow load or for very large size panels, there is the possibility to use additional support for the PV-panels. The additional support consists of a special front and back foot and is fixed to the PV-panel frame in the centre of the long side.

The upright of the back foot can be clicked in position 1 or 2, depending on the panel dimension. The base plate of the back foot can be mounted in both directions, depending on the preference of the installer.

Position 1 is for panel width 977 – 1050 mm

Position 2 is for panel width 1051 – 1135 mm

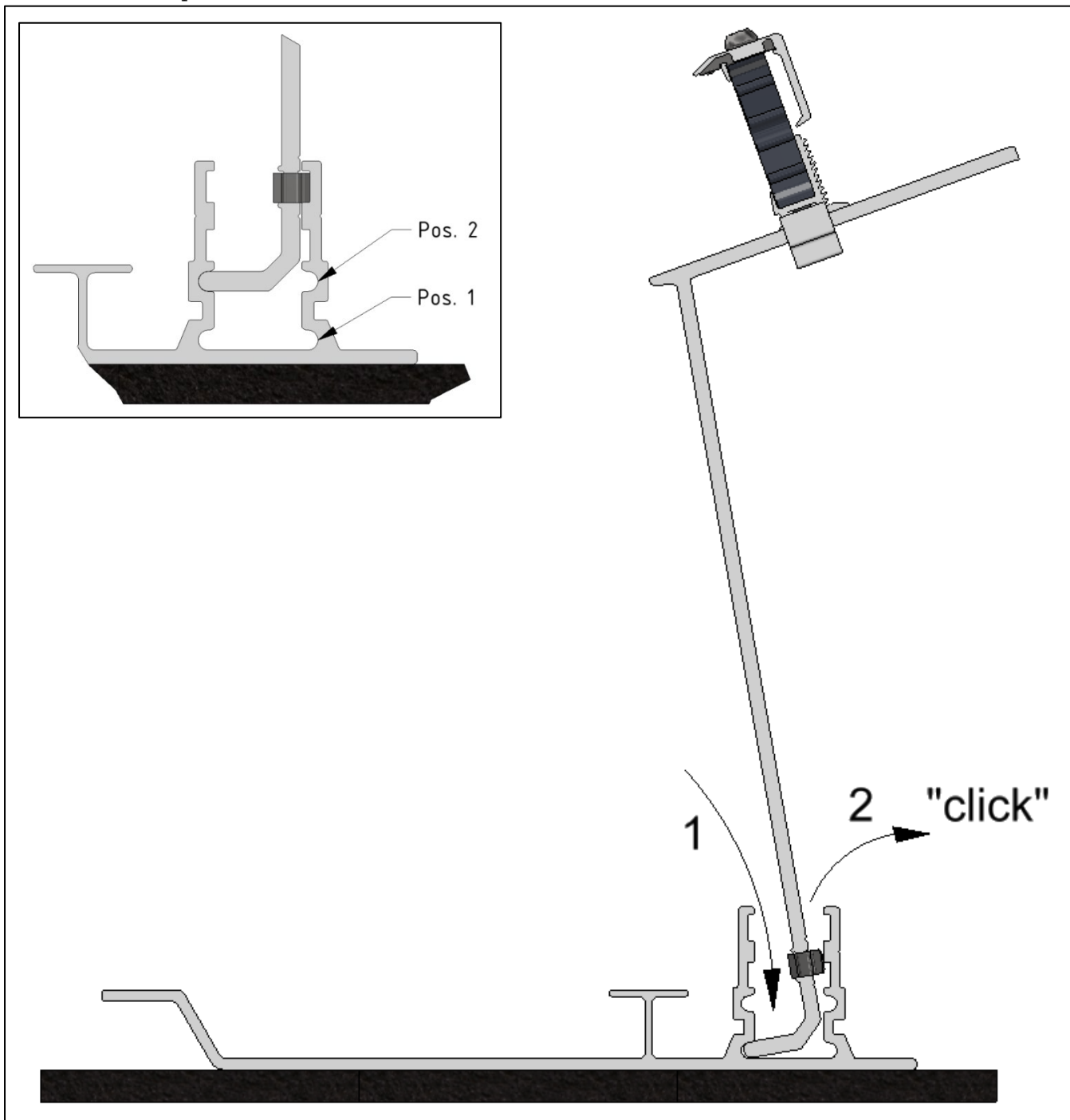

VAN DER VALK



Orientation of the base plate can be in both directions:

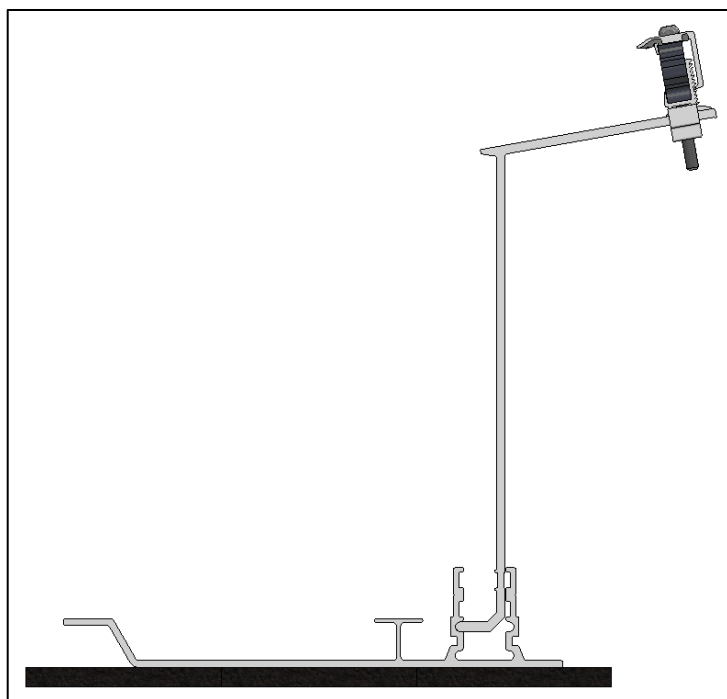

The mounted backfoot can now be placed below the high side of the panel and the clamp can be fixed to the panel frame. The front foot can be fastened to the panel frame on the low side of the panel.

8.6

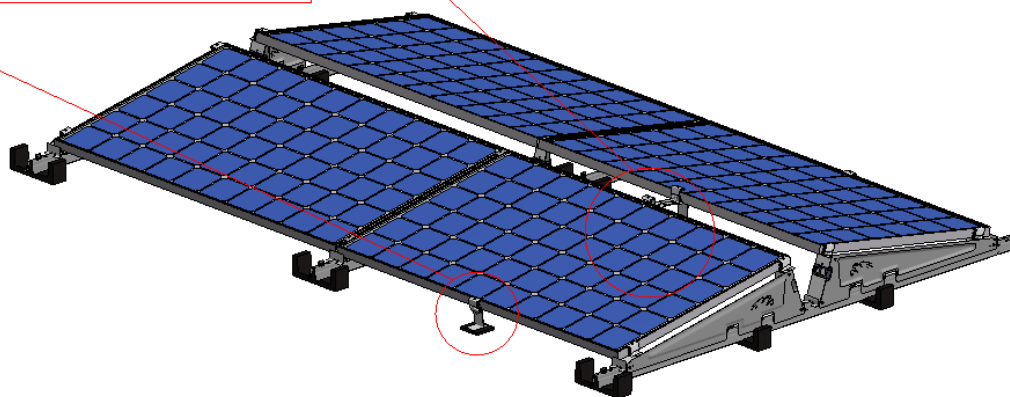
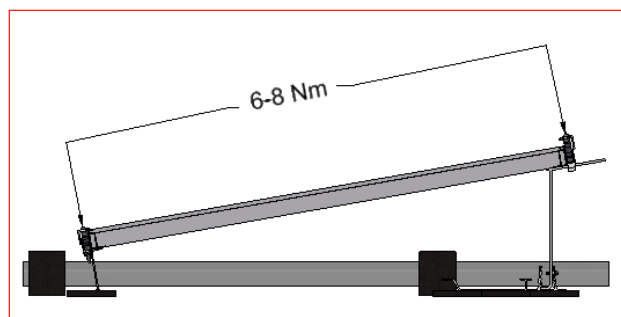
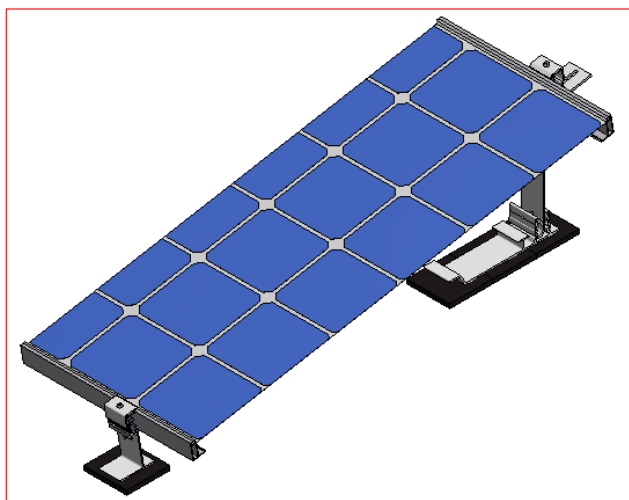

Van der Valk Solar Systems

Van der Valk Solar Systems is since 2009 one of the fastest growing companies in the solar industry and focuses entirely on the development and production of solar mounting systems for pitched roofs, flat roofs and open fields. Van der Valk Solar Systems also has an office and warehouse in the UK, offices in Sweden and Spain and is currently active in 13 countries.

Our mounting systems are developed and produced in our own factory in the Netherlands and stand out thanks to their broad area of application, the very short time in which they can be installed, and the high quality. They are developed according to the latest Eurocodes and therefore comply with the requirements defined for solar systems by banks and insurance companies.

Van der Valk Solar Systems is part of family-owned company Van der Valk Systemen, which has been a household name in the field of moving systems and mounting components since 1963.

Our shared industrial complex consists of 20,000m² of offices and factory spaces. Here we use modern machinery and the latest technologies to quickly and accurately develop, manufacture, and test products and systems.



Solar mounting systems & cable management



Flat roofs



Pitched roofs



Cable management

CONTACT DETAILS | DEVELOPER AND PRODUCER OF SOLAR MOUNTING SYSTEMS



Van der Valk Solar Systems + International

Westernesse 18 - 2635 BG Den Hoorn, The Netherlands
+31 174 25 49 99
sales@valksolarsystems.com

Valk Solar Systems UK + IE

+44 1304 89 76 58
sales@valksolarsystems.co.uk

Valk Solar Systems Ibérica

+34 699 326 544
ventas@valksolarsystems.es

Valk Solar Systems Nordics

+46 7 24 41 60 82
sales@valksolarsystems.se

www.valksolarsystems.com



Van der Valk Solar Systems International



valksolar



Van der Valk Solar Systems International



Valksolar