



AIRPICKER™

AIRGRIPPER™



Pneumatic Working
Devices for Firm and
Precise Holding

Firestone

World's Number 1 
Air Spring.

FIRESTONE INDUSTRIAL PRODUCTS COMPANY

AIRPICKER™

END EFFECTORS

AIRGRIPPER™

END EFFECTORS

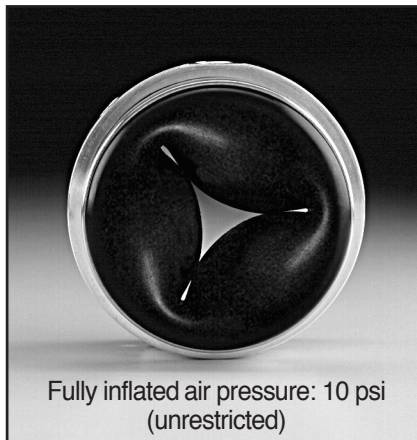
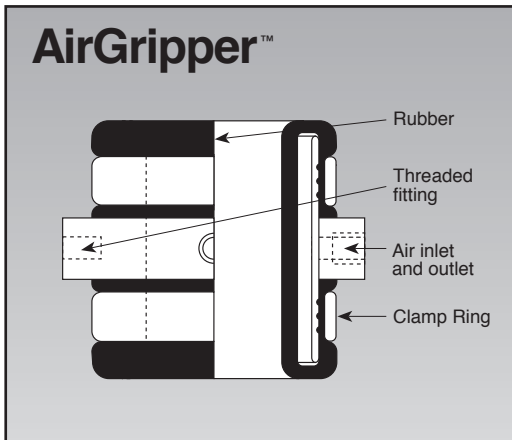
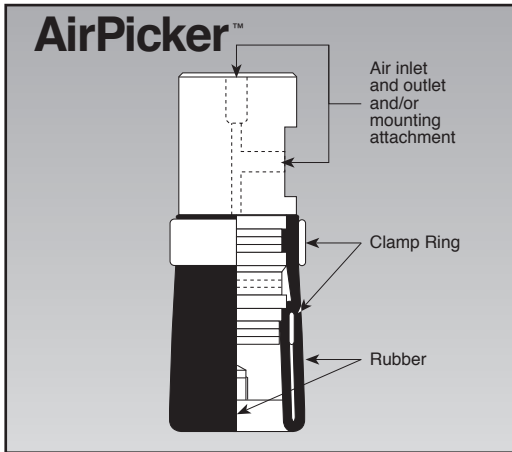

AirPicker™ and AirGripper™ end-effectors move objects of all shapes and sizes.

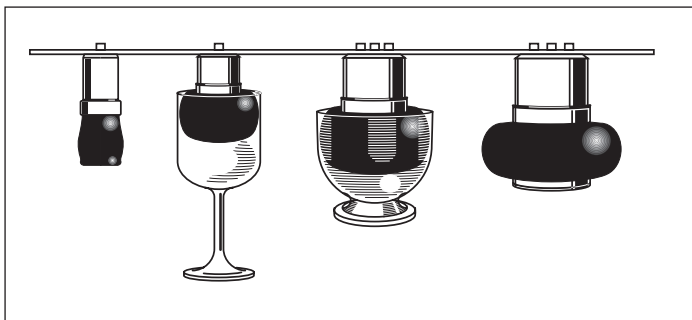

Conforming to multiple sizes and shapes

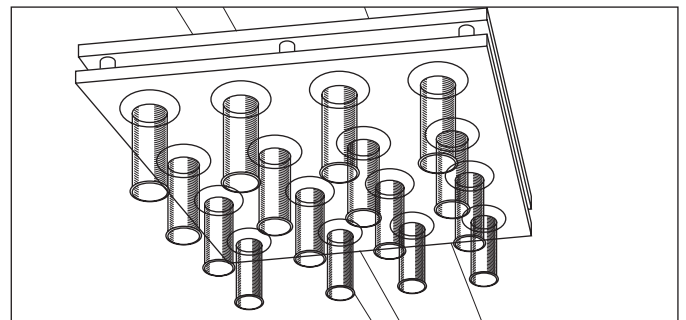

Transferring hot, freshly molded test tubes



Handling and packaging bottles

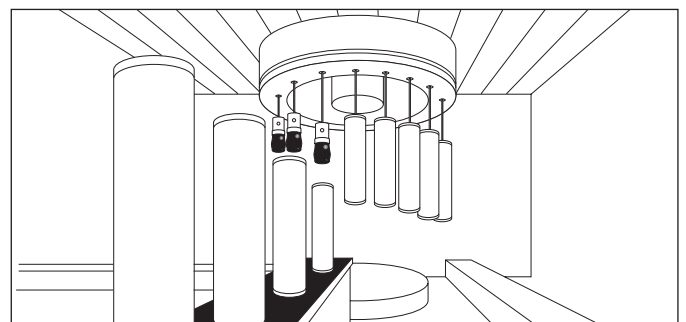

Handling photosensitive copier drums

Firestone end-effector Selection Guide

AirPicker™ end-effector - Neoprene rubber material

Style Number	Rubber Bladder Length (inches/mm)	Deflated Diameter (inches/mm)	Maximum Restricted Pressure Allowed (psig/bar)	Working Diameter Range (inches/mm)	Load Capability in Working Diameter Range at Max. Allowed Pressure (lbs./kg)
P006RCA	0.65 17	0.31 8	55 4	0.33-0.39 8.5-10	3.3-0.3 1.5-0.15
P007RCA	0.65 17	0.37 9	55 4	0.39-0.51 10-13	3.4-0.5 1.5-0.23
P009RCA	0.65 17	0.43 11	55 4	0.47-0.69 12-17	6.6-2.5 3.0-1.1
P010RCA	0.79 21	0.55 14	70 5	0.63-0.83 16-21	9.5-4.4 4.3-2.0
P014RCA	0.87 22	0.75 19	70 5	0.79-1.06 21-27	16.3-6.6 7.4-3.0
P017RCA	0.87 22	0.87 22	70 5	0.91-1.26 23-32	23.0-7.7 10.4-3.5
P019RCA	0.87 22	0.98 25	70 5	1.02-1.54 26-40	29.8-8.0 13.5-3.6
P022RCA	1.10 28	1.10 28	70 5	1.18-1.73 30-44	30.0-15.0 13.6-6.8
P025RCA	1.34 34	1.14 29	70 5	1.26-2.13 32-54	55.0-20.0 24.9-9.1
P035TCA	1.65 42	1.65 42	70 5	1.77-2.56 45-65	77.0-25.0 34.9-11.3
P045TCA	2.09 53	2.00 51	70 5	2.28-3.35 58-85	130.0-50.0 59.0-22.7
P055TCA	2.09 53	2.48 63	70 5	2.76-4.13 70-105	160.0-66.0 72.6-29.9

AirPicker™ end-effector - Silicone rubber material

P014RCAS	0.87 22	0.79 20	25 1.8	0.83-1.00 22-25	2.2-0.5 1.0-0.23
P017RCAS	0.87 22	0.91 23	25 1.8	1.00-1.18 25-30	3.3-0.4 1.5-0.50
P019RCAS	0.91 23	1.06 27	25 1.8	1.18-1.40 30-35	2.3-1.1 1.0-0.50
P022RCAS	1.14 29	1.14 29	25 1.8	1.26-1.58 32-40	5.5-1.3 2.5-0.60
P025RCAS	1.26 32	1.22 31	25 1.8	1.34-1.66 34-42	7.7-2.3 3.5-1.0
P035RCAS	1.50 38	1.65 42	25 1.8	1.81-2.27 46-58	8.0-4.5 3.6-2.0

AirGripper™ end-effector - Neoprene rubber material

Style Number	Rubber Bladder Length (inches/mm)	Deflated Diameter (inches/mm)	Maximum Restricted Pressure Allowed (psig/bar)	Working Diameter Range (inches/mm)	Load Capability in Working Diameter Range at Max. Allowed Pressure (lbs./kg)
G020GCA	1.50 38	0.70 18	20 1.5	0.20-0.60 5-15	4.0-11.0 1.8-5.0
G030GCA	2.00 51	1.10 28	20 1.5	0.40-1.00 10-25	9.0-27.0 4.1-12.3
G040GCA	2.10 53	1.50 38	20 1.5	0.60-1.40 15-35	20.0-36.0 9.1-16.3
G050GCA	2.20 56	1.90 48	20 1.5	0.80-1.80 20-45	20.0-50.0 9.1-22.7

AirGripper™ end-effector - Silicone rubber material

Style Number	Rubber Bladder Length (inches/mm)	Deflated Diameter (inches/mm)	Maximum Restricted Pressure Allowed (psig/bar)	Working Diameter Range (lbs./kg)
G020GCAS	1.50 38	0.70 18	15 1	0.20-0.60 5-15
G030GCAS	2.00 51	1.10 28	15 1	0.40-1.00 10-25
G040GCAS	2.10 53	1.50 38	15 1	0.60-1.40 15-35
G050GCAS	2.20 56	1.90 48	15 1	0.80-1.80 20-45

Imperial AirPickers are standard with threaded nose cone holes. Firestone supplies nose cones according to the table to the right.

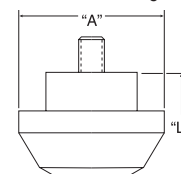

	"A"	"L"
N010	0.58	0.690
N014	0.78	0.865
N017	0.90	0.865
N019	1.10	0.865
N022	1.13	0.865
N025	1.17	0.865
N035	1.68	0.990
N045	2.03	0.990
N055	2.51	0.990

Advantages

- Conform to Any Shape
- Multiple Sizes Handled with One Gripper
- Delicate Handling
- Wide Size Range
- High Load Capacity
- Non-marring Contact
- No Lubrication Required
- Low Cost
- Long Life in a Dusty Environment

Precautions

Pressure

AirPicker™ and AirGripper™ end-effectors should not be used past their maximum recommended working pressure. This pressure varies depending on the fabric reinforcement and rubber material.

Media

Air is the normal media used to inflate the Firestone end-effectors. Nitrogen can also be used to decrease the potential for oxidation and reduce permeation.

Temperature

The minimum and maximum recommended working temperatures for the following rubber materials are 0°F to 125°F (-18°C to 52°C) for neoprene and -22°F to 320°F (-30°C to 160°C) for silicone.

Contact Surface

The preferred contact surface for AirPicker and AirGripper end-effector is smooth and dry. Any threads, burrs or sharp objects will decrease the useful life of the rubber bladder. Protective neoprene sleeves are available to increase the life of the bladder when the contact surface is detrimental.

Minimum and Maximum Working Diameter

The maximum working diameter range given for each end-effector insures a firm hold on the object as well as maximizing the life of the rubber. Exceeding this diameter range will increase the strain on the rubber and cause premature damage. Using an end-effector below the range of the working diameter will abrade the rubber as it is placed into and removed from an object.

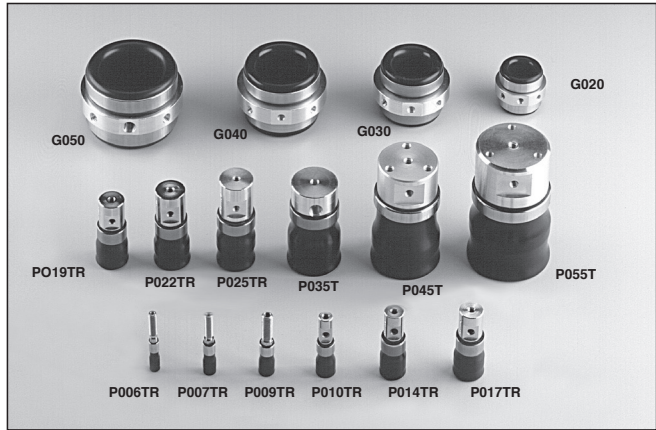

Unrestricted Inflation

Repeated unrestricted inflation will prematurely damage a Firestone end effector. If the application requires unrestricted inflation, a protective rubber sleeve or a casing surrounding the rubber is recommended. The sleeve or casing will restrict the diameter of the rubber and reduce the strain.

Preconditioning

All of the fabric reinforced rubber bladders have small pieces of cotton threads, called pick cords, used to hold the nylon tire chords of the fabric plies together during production. Before the end-effectors are able to reach recommended working diameters, these pick cords must be broken through preconditioning. In order to break these pick cords the end-effectors must be inflated unrestricted at the maximum recommended working pressure for 30 cycles. NOTE: Excessive unrestricted inflation will harm the rubber.

Contaminates

Neoprene, silicone and EPDM have their advantages and disadvantages when in contact with lubricants, acids, solutions, etc. Please contact Firestone with specific applications.

Storage

The best storage environment is a dark, dry area at normal room temperature.

AirPicker™ AirGripper™

Distributed by:

An ISO 9001 - 2015 Certified Organization



B 26, 2nd Floor, Sector 67, Noida, Uttar Pradesh, Pin 201307, India
Cust.Care : 9599709571/72 Email : sales@ascindia.com
Website : www.ascindia.com

Firestone

World's Number 1
Air Spring.

FIRESTONE INDUSTRIAL PRODUCTS COMPANY

www.fsip.com