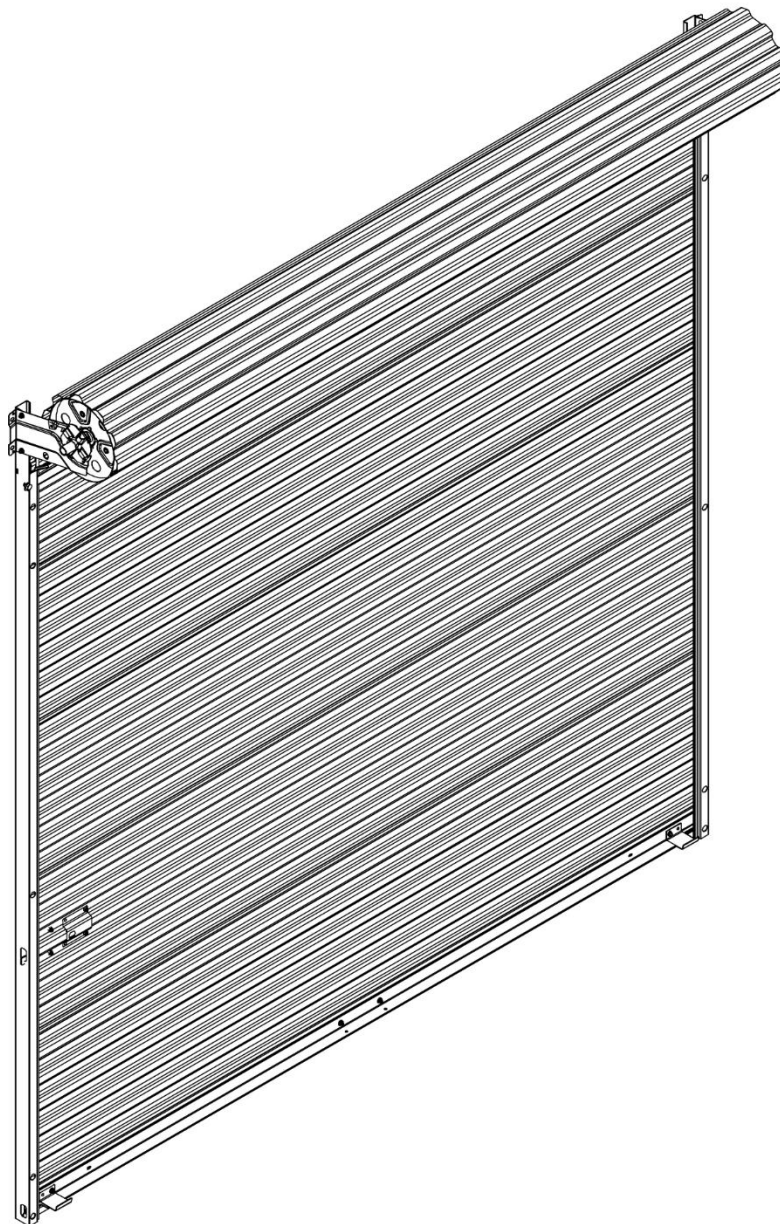


# RESIDENTIAL - MINI STORAGE ROLL UP DOORS INSTALLATIONA MANUAL



## **IMPORTANT INFORMATION**

DO NOT CUT TAPE AND PLASTIC WRAP THAT HOLDS THE DOOR IN A ROLL UNTIL YOU ARE DIRECTED TO DO SO. DBCI DOORS MUST BE INSTALLED BY TRAINED ROLLING DOOR TECHNICIANS QUALIFIED TO INSTALL PRODUCT SAFELY WITH PROPER KNOWLEDGE, TOOLS, SAFETY AND INSTALLATION EQUIPMENT. CAREFULLY READ INSTALLATION INSTRUCTIONS. FAMILIARIZE YOURSELF WITH ALL INSTALLATION PROCEDURES, WARNINGS, CAUTIONS, AND NOTES BEFORE ATTEMPTING TO INSTALL DOOR. DBCI DOOR CORPORATION WILL NOT WARRANTY OR ACCEPT RESPONSIBILITY FOR DOORS NOT INSTALLED PER THESE INSTALLATION INSTRUCTIONS.

## **- IMPORTANT SAFETY INFORMATION -**

- CAREFULLY READ INSTALLATION INSTRUCTIONS. FAMILIARIZE YOURSELF WITH ALL INSTALLATION PROCEDURES, WARNINGS, CAUTIONS, AND NOTES BEFORE ATTEMPTING TO INSTALL DOOR.
- INSPECT RECEIVED DOOR ASSEMBLY FOR VISIBLE DAMAGE AND/OR COMPONENT SHORTAGES.
  - a. SHIPPING DAMAGE: FILE DAMAGE CLAIM IMMEDIATELY WITH FREIGHT CARRIER. SUPPLY DOOR SUPPLIER WITH PHOTO DOCUMENTATION TO RECEIVE REPLACEMENT COMPONENTS.
  - b. PART SHORTAGE: IMMEDIATELY CONTACT DOOR SUPPLIER WITH PARTS SHORTAGE CLAIM. ORDER NUMBER, DOOR MODEL, PHOTO DOCUMENTATION ARE ENCOURAGED TO EXPEDITE PROCESS.
  - c. INCORRECT PARTS: IF RECEIVED DOOR COMPONENTS AND PARTS DO NOT MATCH THOSE REFERENCED IN THESE INSTALLATION INSTRUCTIONS, IMMEDIATELY CONTACT DOOR SUPPLIER.
- IF AT ANY TIME BEFORE OR DURING INSTALLATION YOU ARE UNFAMILIAR, UNCOMFORTABLE, OR CONFUSED BY INSTALLATION PROCEDURES OUTLINED IN THESE INSTALLATION INSTRUCTIONS DO NOT ATTEMPT TO INSTALL DOOR ASSEMBLY. IMMEDIATELY CONTACT DOOR SUPPLIER WITH QUESTIONS/CONCERNS.

**DBC DOORS MUST BE INSTALLED BY TRAINED ROLLING DOOR TECHNICIANS QUALIFIED TO INSTALL PRODUCT SAFELY WITH PROPER KNOWLEDGE, TOOLS, SAFETY AND INSTALLATION EQUIPMENT.**

## **- READ ALL WARNINGS BELOW -**

- USE APPROPRIATE SAFETY EQUIPMENT TO AVOID SERIOUS INJURY.
- CLEAR FLOOR AT OPENING OF ALL DEBRIS BEFORE INSTALLING PRODUCT.
- USE APPROPRIATE LIFTING EQUIPMENT AND CORRECT LIFTING PROCEDURES TO AVOID DAMAGE, SERIOUS INJURY OR DEATH.
- MOVING DOOR COULD RESULT IN DEATH OR SERIOUS INJURY. DO NOT CLOSE DOOR UNTIL DOORWAY IS CLEAR.
- CONTROL THE SPEED OF THE DOOR DURING MANUAL OPERATION.
- DO NOT STAND OR WALK UNDER A MOVING DOOR.
- KEEP DOORWAY CLEAR AND IN FULL VIEW WHILE OPERATING DOOR.
- DO NOT PERMIT CHILDREN TO PLAY ON, NEAR, OR WITH DOOR, OR OPERATE DOOR CONTROLS.
- UNLOCK DOOR BEFORE OPENING DOOR.
- SENSING DEVICES ON MOTOR OPERATING DOORS SHOULD BE TESTED FREQUENTLY.
- VISUALLY INSPECT DOOR AND HARDWARE MONTHLY FOR WORN AND/OR BROKEN PARTS AND CHECK IF DOOR OPERATES FREELY. DO NOT OPERATE A DOOR WITH A BROKEN SPRING.
- COMPONENTS ARE UNDER EXTREME SPRING TENSION COULD RESULT IN DEATH OR SERIOUS INJURY.
- DOOR MUST BE FULLY OPENED WHEN MAKING ADJUSTMENTS.

**► Retain these instructions for reference.**

# **HANDLE WITH CARE - DO's & DON'T's**

## **DO's**

- CAREFULLY INSPECT ALL PRODUCT FOR DAMAGE UPON RECEIPT.
- USE PROTECTIVE FOAM BETWEEN PRODUCT AND ANY SURFACE OR OBJECT IT MAY COME INTO CONTACT WITH WHILE IN TRANSIT AND/OR STORAGE.
- WHEN SECURING PRODUCT FOR TRANSIT, USE FOAM BARRIER BETWEEN PRODUCT AND STRAPS, ROPES, ETC.
- CAREFULLY UNLOAD PRODUCT FROM ANY TYPE OF CRATING MATERIAL ASSURING NO CONTACT WITH FASTENERS OR SHARP EDGES.
- CLEAR FLOOR AT OPENING OF ALL DEBRIS BEFORE INSTALLING PRODUCT.
- SINGLE PERSON LIFTING OF PRODUCT COULD CAUSE INJURY. USE ASSISTANCE WHEN MOVING OR LIFTING.
- INSTALL PRODUCT WITH APPROPRIATE LIFTING EQUIPMENT ASSURING A PROTECTIVE BARRIER IS MAINTAINED BETWEEN PRODUCT AND ANY SURFACE OR OBJECT IT MAY COME INTO CONTACT WITH.

## **DON'T's**

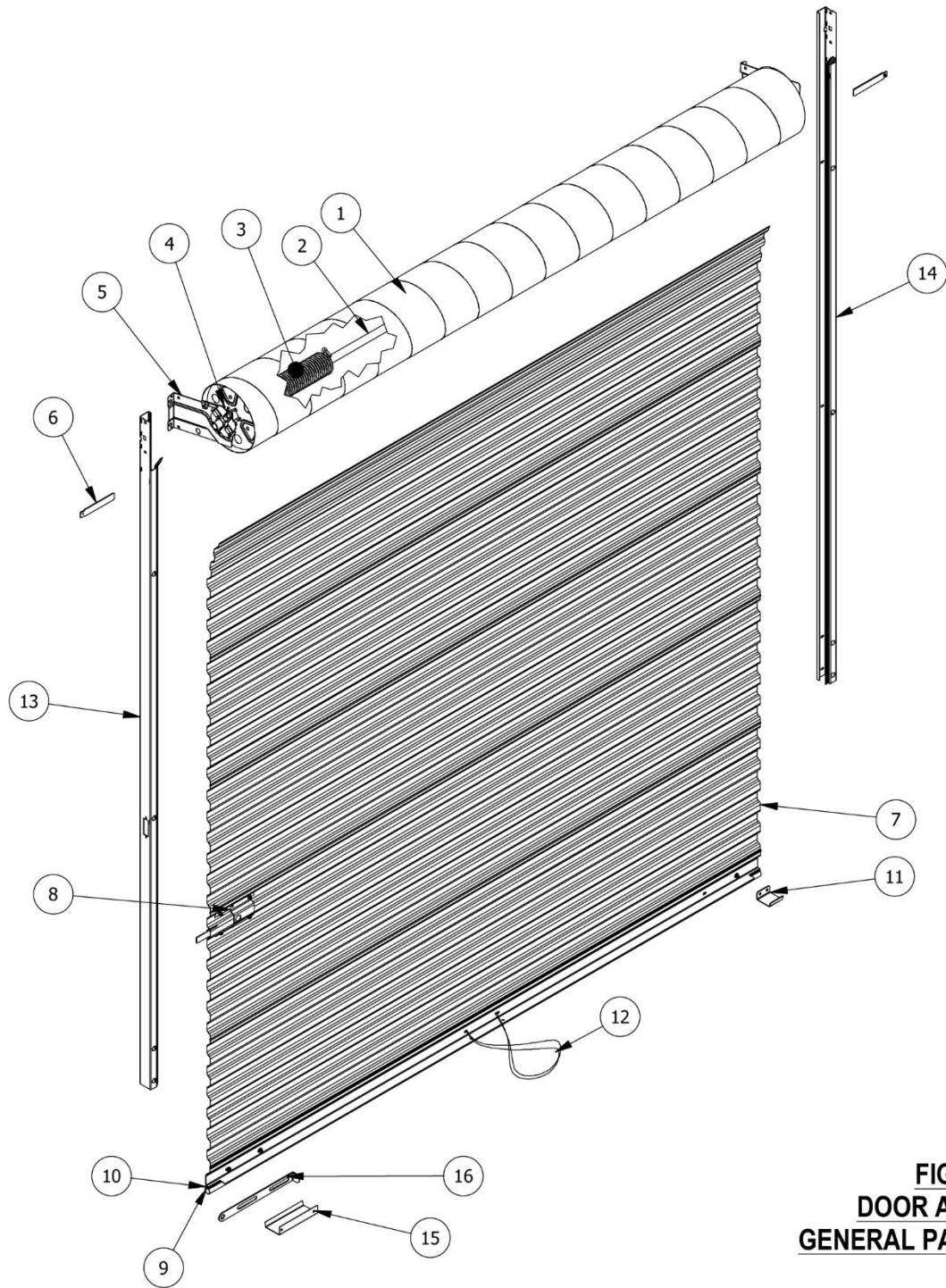
- DO NOT - STAND ON PRODUCT.
- DO NOT - CLIMB ON PRODUCT.
- DO NOT - WALK ON PRODUCT.
- DO NOT - DROP PRODUCT.
- DO NOT - SLIDE PRODUCT ACROSS ANY SURFACE.
- DO NOT - THROW OR TOSS PRODUCT.
- DO NOT - SET OR STACK PRODUCT ON GRAVEL, DEBRIS, OR UNEVEN SURFACES.
- DO NOT - ALLOW SHARP OBJECTS TO COME IN CONTACT WITH PRODUCT.
- DO NOT - LEAVE PRODUCT UNSECURED WHILE IN TRANSIT OR DURING INSTALLATION.

**FAILURE TO ADHERE TO THE ABOVE CONDITIONS WILL RESULT IN PERSONAL INJURY OR PRODUCT DAMAGE NOT COVERED UNDER DBCI PRODUCT WARRANTY. ALWAYS HANDLE PRODUCT WITH CARE, AND REVIEW ALL INSTRUCTIONS, WARNINGS, AND NOTES BEFORE INSTALLING PRODUCT.**

**REVIEW DOOR ASSEMBLY AND GENERAL PARTS DESCRIPTIONS BILL OF MATERIAL FROM PAGE 4, FIGURE 1 TO FAMILIARIZE YOURSELF WITH COMMON PARTS OF ROLLING SHEET DOOR ASSEMBLY.**

**DOOR ASSEMBLIES ARE MANUFACTURED PER OPENING WIDTHS AND HEIGHTS SPECIFIED AT TIME OF ORDER. WILL NOT BE HELD RESPONSIBLE FOR OPENING WIDTHS OR HEIGHTS THAT DO NOT MATCH THOSE SPECIFIED AT TIME OF ORDER.**

## DOOR ASSEMBLY & GENERAL PART DESCRIPTIONS



**FIGURE 1:  
DOOR ASSEMBLY &  
GENERAL PART DESCRIPTION**

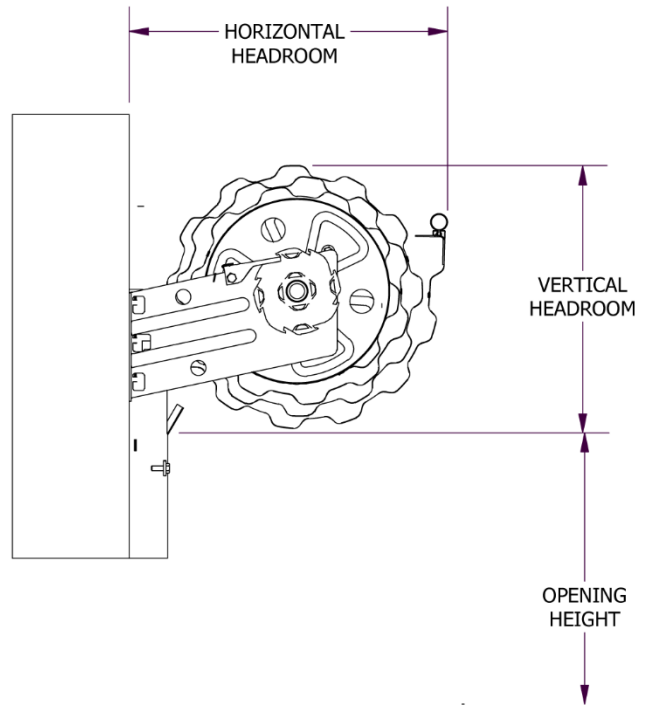
### GENERAL BILL OF MATERIALS

ITEM	DESCRIPTION / PART NUMBER	ITEM	DESCRIPTION / PART NUMBER	ITEM	DESCRIPTION / PART NUMBER
1	9 1/2" Spiral Barrel	7	26 Ga. Corrugated Curtain	13	LH Guide
2	1" O.D. Axle	8	Mini Latch	14	RH Guide
3	Spring/Counterbalance Assembly	9	Bottom Bar Astragal	15	Comm. Step Plate (Optional)
4	Tensioner Ratchet Wheel	10	Bottom Bar Assembly	16	Comm. Slide Lock (Optional)
5	Bracket	11	Mini Clip	17	
6	Headstop	12	Rope	18	

## HEADROOM/SIDEROOM DIMENSIONAL REFERENCES

**FIGURE 2: HEADROOM REQUIREMENT CHART**

HEADROOM REQUIREMENT		
OPENING HEIGHT	VERTICAL HEADROOM	HORIZONTAL HEADROOM
THRU 7'-4"	15 ½"	17"
OVER 7'-4" THRU 8'8"	16"	17 ½"
OVER 8'8" THRU 10'-0"	17"	18 ½"

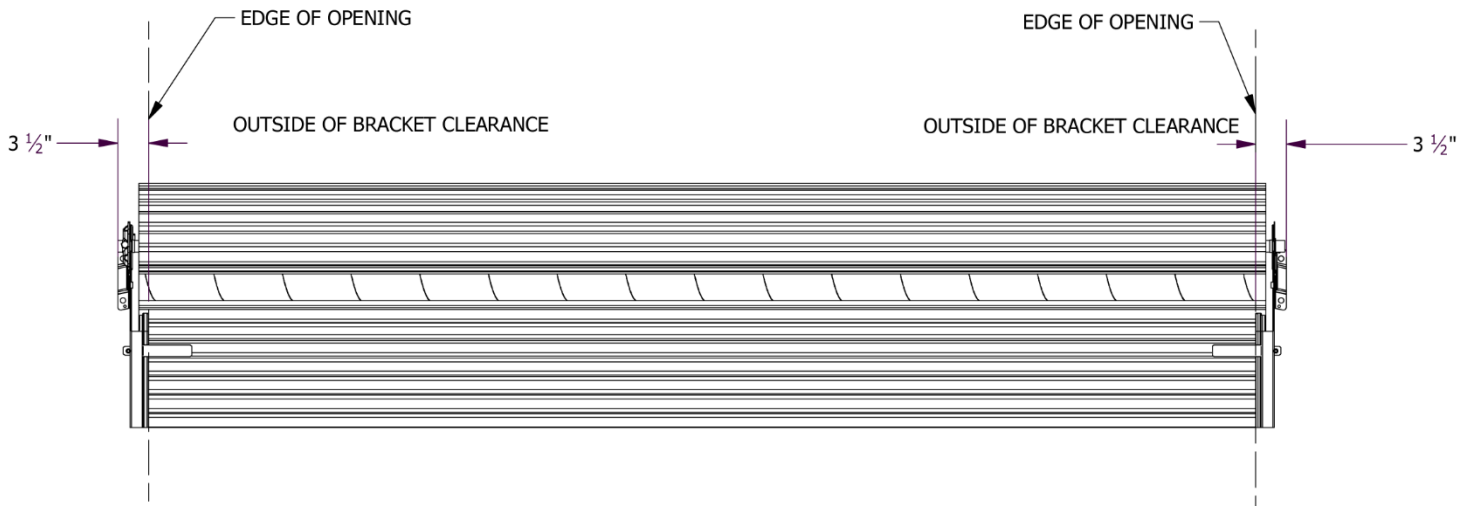


**FIGURE 3: SIDEROOM CLEARANCE REQUIREMENT**

OPERATION	OUTSIDE OF BRACKET TENSIONER END	OUTSIDE OF BRACKET DRIVE END (NON-TENSIONER)
PUSH-UP	3 ½"	3 ½"
PANTHEON	3 ½"	3 ½"
ATA EZ Roller 14	3 ½"	6 ½"

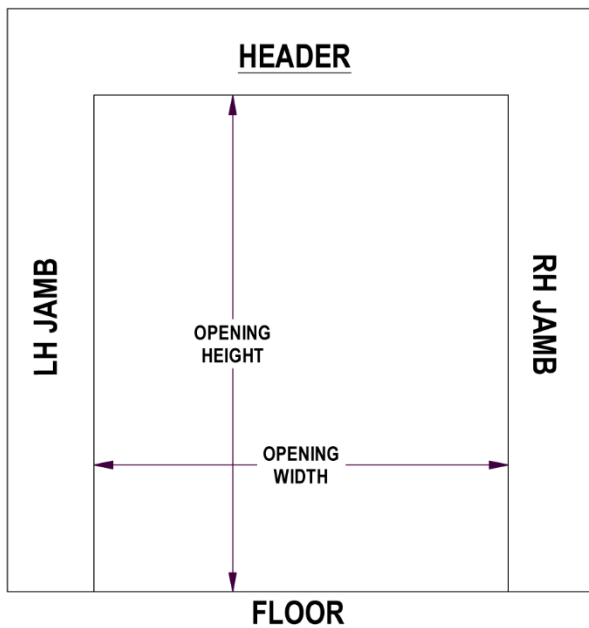
**IMPORTANT NOTES**

- DIMENSIONS ARE REFERENCED FROM THE EDGE OF THE OPENING.
- FOR CRITICAL FITS DUE TO REDUCED AVAILABLE HEADROOM OR SIDEROOM CLEARANCES, CONSULT FACTORY.



## STEP 1: WALL OPENING

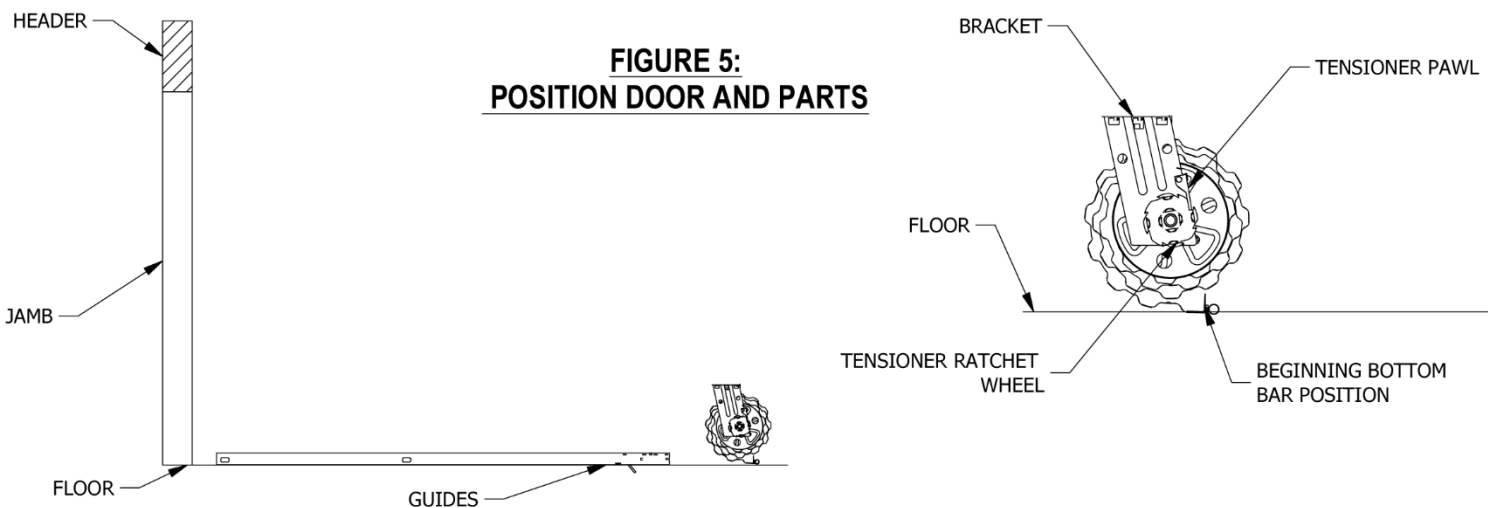
- ▶ Check wall opening width and height and verify these measurements against size of door to be installed.
- ▶ Verify that jambs are plumb.
- ▶ Check floor and header for level.
- ▶ Check for adequate side clearance at jambs and clearance above and at sides of header. Check vertical and horizontal headroom requirements. **See Figures 2 & 3** for minimum requirements.
- ▶ Verify that guide mounting surface on the jamb is flush.
- ▶ Make sure all parts required for installation are with the door.



**FIGURE 4:  
WALL OPENING**

## STEP 2: POSITION DOOR & PARTS

- ▶ Verify floor area is clean in order to prevent damage to curtain.
- ▶ Inside the building, place left guide on floor perpendicular to opening with guide bottom close to left jamb and the top toward inside of building. Repeat step to the right side.
- ▶ Place door on floor at top of and between guides. Rotate door as necessary to locate bottom bar against floor. **See figure 5.**
- ▶ Distribute hardware parts to appropriate areas.

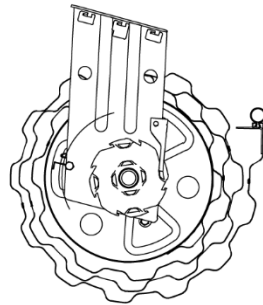
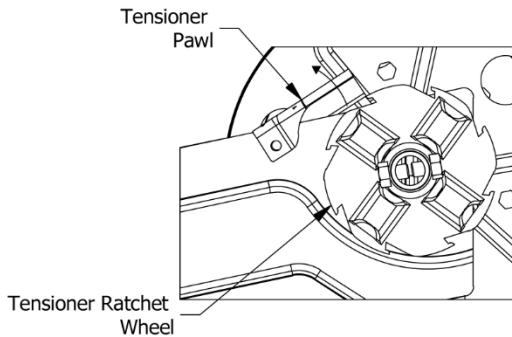


**FIGURE 5:  
POSITION DOOR AND PARTS**

## STEP 3: GUIDES TO BRACKET POSITIONING

- ▶ At tensioner end of door, lift flange on tensioner pawl until end of the pawl clears the tensioner ratchet wheel. Rotate bracket in order to position short leg end upwards. Release flange on pawl and allow end to engage with the nearest tooth on the tensioner ratchet wheel.

**FIGURE 6:  
MINI BRACKET POSITIONING**



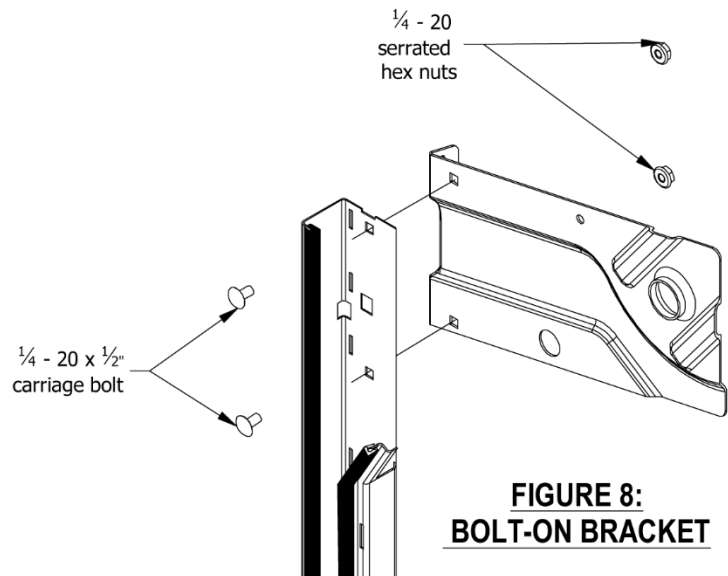
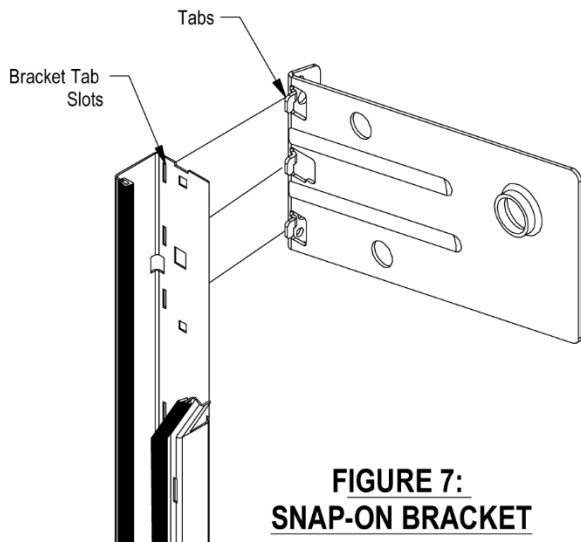
**WARNING!**  
ENSURE TENSIONER PAWL IS FULLY ENGAGED WITH TENSIONER RATCHET WHEEL TOOTH. *SEE FIGURE 6* FOR VISUAL REFERENCE.

## SNAP - ON BRACKET INSTALLATION

- ▶ Bring top end of guide in alignment with bracket and insert tabs on bracket into tab slots in guide. *(Figure 7)*
- ▶ Slide bracket and guide together until locking tab in guide fully engages notch in bracket.
- ▶ If locking tab does not fully engage with bracket notch, use hammer and punch to bend tab into bracket notch.
- ▶ Repeat above steps for non-tensioner bracket guide. The bracket will require being held in position.

## BOLT - ON BRACKET INSTALLATION

- ▶ Attach door bracket to guides. Use two (2) each  $\frac{1}{4}$  - 20 x  $\frac{1}{2}$ " carriage bolts and  $\frac{1}{4}$  - 20 serrated hex nuts per bracket. *(Figure 8)*



### WARNING!

DOOR CAN FALL IF BOTH BRACKETS ARE NOT SECURELY FASTENED TO THE JAMBS. ALL FASTENERS ATTACHING BRACKETS TO JAMBS MUST FIT SECURELY INTO A STRUCTURAL MEMBER OR SURFACE. IF DOOR FALLS, SERIOUS INJURY OR DEATH AND/OR DAMAGE TO THE DOOR CAN RESULT.

## STEP 4: LIFTING DOOR ASSEMBLY

- Move door and guide assemblies toward wall opening with bottom of guides resting next to jambs.
- Lift door assembly evenly, pivoting around bottom of guides.  
(See Figure 9)

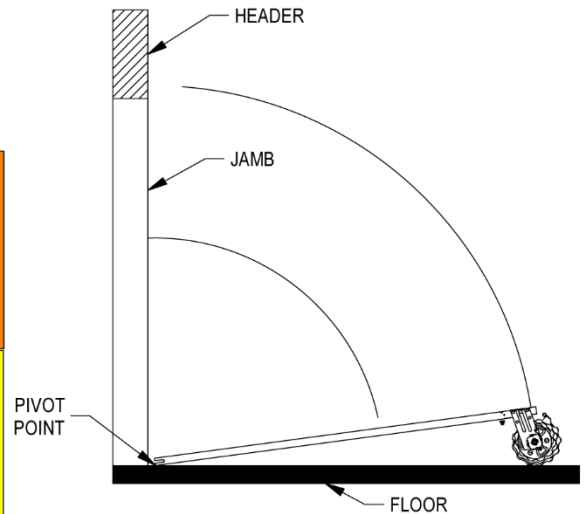
### NOTE:

- DOORS OVER 8'-0" HIGH WILL REQUIRE A MECHANICAL LIFTING DEVICE TO LIFT DOOR & GUIDES INTO MOUNTING POSITION.
- ANY MECHANICAL LIFTING DEVICE SUCH AS FORKLIFTS OR GENIE LIFTS, MUST BE PADDED TO PREVENT CURTAIN DAMAGE.

### WARNING!

TWO INSTALLERS ARE REQUIRED TO LIFT DOOR ASSEMBLY INTO POSITION AGAINST JAMBS. THE GUIDES ARE NOT DESIGNED TO SUPPORT THE DOOR WEIGHT DURING A ONE MAN INSTALLATION. ATTEMPTING INSTALLATION WITH ONLY ONE INSTALLER CAN RESULT IN SERIOUS INJURY AND/OR DAMAGE TO DOOR. DO NOT LEAVE DOOR UNATTENDED UNTIL IT IS SECURELY ATTACHED TO JAMBS

**FIGURE 9:  
LIFTING DOOR ASSEMBLY**



### NOTE:

FOR OPENING HEIGHTS OVER 8'-8", CLAMP BOTTOM OF BRACKETS TO GUIDES WITH LOCKING PLIERS IN ORDER TO ENSURE RIGIDITY OF TOP OF GUIDE WHILE LIFTING. REMOVE PLIERS AFTER SECURING BRACKETS TO JAMBS.

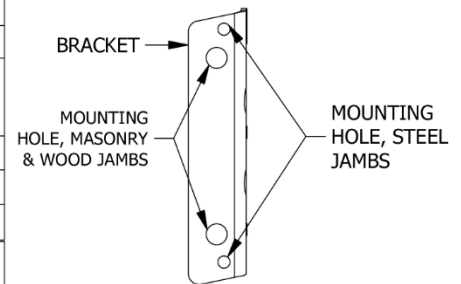
## STEP 5: GUIDES AND BRACKETS TO JAMB

- Attach brackets and guides to jambs using fasteners shown in **Table 1**.
- The guides should be mounted centered about the opening, set at curtain width +1". Back of guide to back of guide. **See figure 10**. Both guides must be plumb and door must be level.
- The appropriate fastener must be installed in each corresponding hole location in bracket and guides.

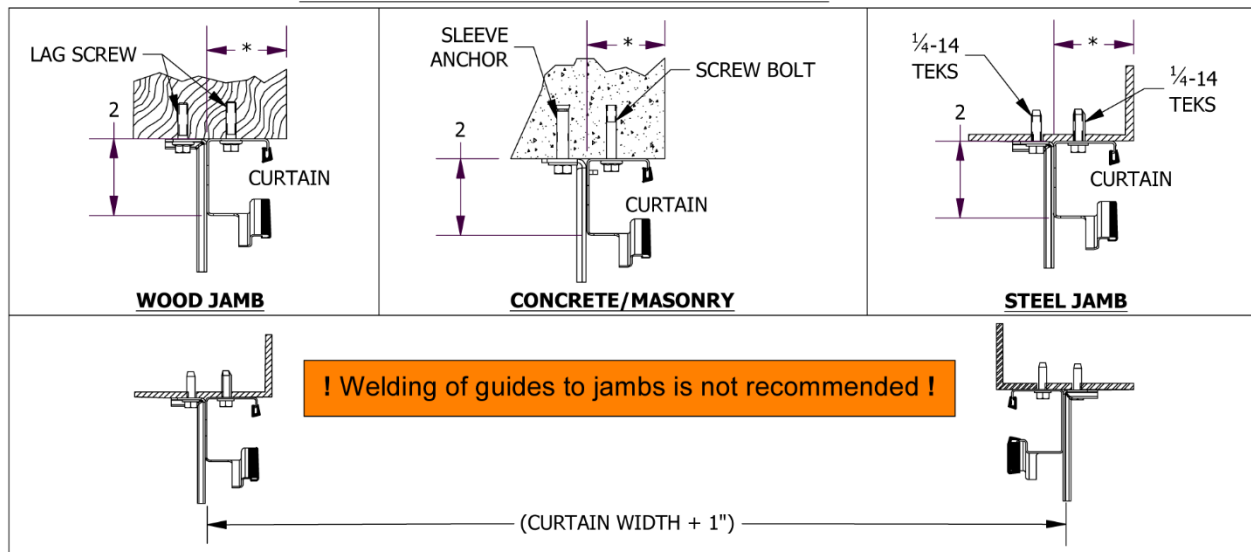
**TABLE 1: WALL FASTENERS INCLUDED FOR JAMB ATTACHMENT OF BRACKETS AND GUIDES**

ITEM	JAMB	FASTENERS	DRILL SIZE
Brackets and Guides	Concrete/Masonry	1/4" x 1 3/4" DeWalt Screw - Bolt (Guides)	1/4" x 1 3/4" SDS
		5/16" x 1 1/2" Sleeve anchor (Bracket)	3/8" x 1 3/4" SDS
Brackets and Guides	Steel-Structure (Exterior)	1/4" - 14 x 1" TEKS Screw	None
Brackets and Guides	Steel-Rollup Frame (Interior)	1/4" - 14 x 7/8" Stitch TEKS Screw	None
Brackets and Guides	Wood	1/4" - 10 x 1" Lag Screw	None

\* 1 3/4" For doors with 2 1/2" Curtain add. (See Figure 10)  
\* 2" For doors with 3 Curtain add. (See Figure 10)

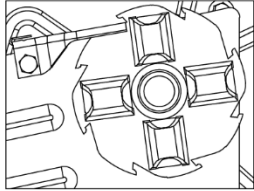


**FIGURE 10: BACK OF GUIDE TO BACK OF GUIDE**

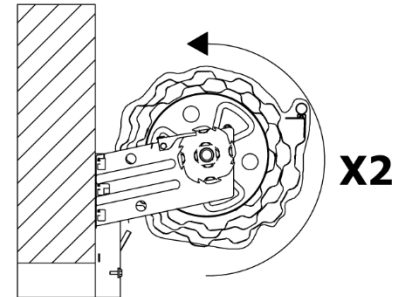


## STEP 6: SETTING INITIAL SPRING TENSION

- ▶ Before applying initial spring tension, ensure tensioner pawl is fully engaged with tensioner ratchet wheel tooth.  
*See Figure 11* below for visual reference.
- ▶ Rotate door two (2) revolutions in the direction that would send the bottom bar down through the guides.
- ▶ While firmly holding the door at the bottom bar, cut the tape and plastic wrap that holds the door in a coil. Direct the bottom bar down into the guides stopping just past the head stop area and hold securely through completion of *Step 7*.

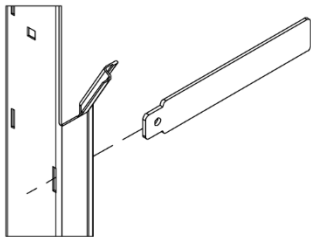


**FIGURE 11:  
SETTING INITIAL SPRING TENSION**

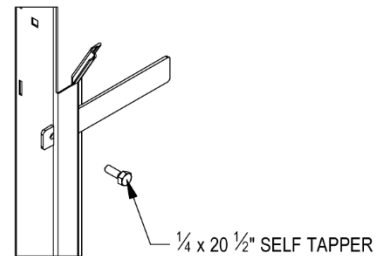


## STEP 7: HEAD STOPS

- ▶ Slide head stop from inside of each guide. *See figure 12*.
- ▶ Secure each head stop to guide with  $\frac{1}{4}$  -  $\frac{1}{2}$ " Self Tapper.

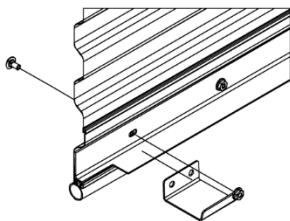


**FIGURE 12:  
HEAD STOP**

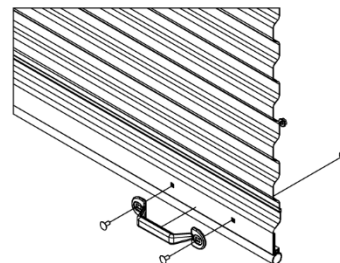


## STEP 8: INSTALLING MINI CLIP

- ▶ Install mini clip at each end on inside of bottom bar using existing single  $\frac{1}{4}$  - 20 x  $\frac{5}{8}$ " carriage bolt and nut.  
*See figure 13*.
- ▶ Install handle(s) on outside of bottom bar using  $\frac{1}{4}$  - 20 x  $\frac{5}{8}$ " carriage bolts and nuts. *See figure 14*.
- ▶ Install rope in holes at the center of horizontal leg of the bottom bar angle.



**FIGURE 13:  
MINI CLIP**



**FIGURE 14:  
HANDLE**

### NOTE:

FOR DOORS GREATER THAN 6' WIDE TWO (2) HANDLES WILL BE PROVIDED FOR INSTALLATION @ CENTER & LATCH END OF BOTTOM BAR.

### WARNING!

INSTALLATION OF MINI CLIPS ARE REQUIRED. FAILURE TO PROPERLY INSTALL CLIPS WILL RESULT IN THE DOOR CURTAIN TO TRAVEL BEYOND THE GUIDES RESULTING IN DOOR DAMAGE AND/OR PERSONAL INJURY.

## NOTE:

MANUAL ADJUSTMENTS OF SPRING TENSION MAY BE REQUIRED. ADJUSTMENTS ARE TO BE MADE USING  $\frac{3}{8}$ " DIAMETER WINDING BAR. WHEN MAKING ADJUSTMENTS, ENSURE TENSIONER PAWL IS FULLY ENGAGED WITH TENSIONER RATCHET WHEEL TOOTH BEFORE REMOVING WINDING BAR FROM IT. **SEE FIGURE 15** FOR VISUAL REFERENCE

## STEP 9: CHECK DOOR OPERATION

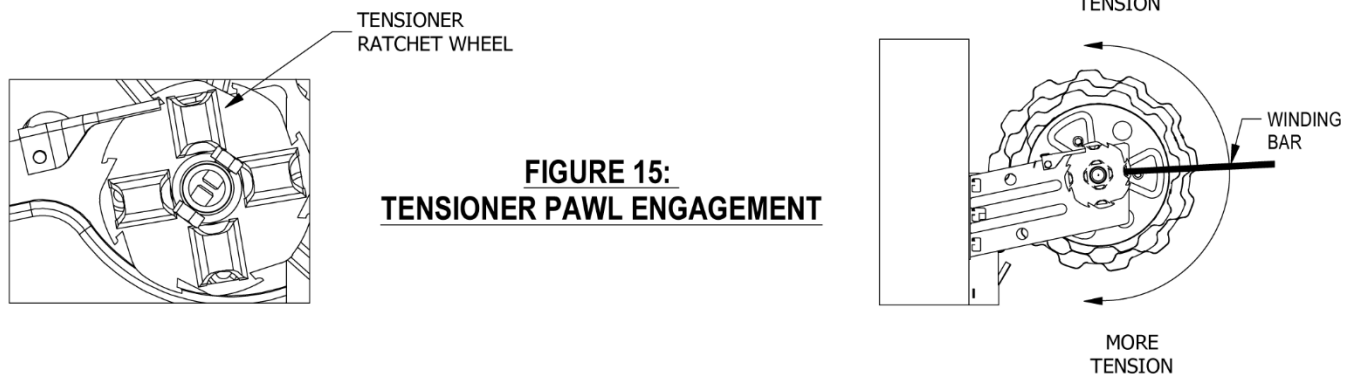
- ▶ Lower and raise the door to test door balance
- ▶ If door is easy to close, but hard to open; increase spring tension. **See step 10**
- ▶ If door is hard to close, but easy to open; decrease spring tension. **See step 10**

## STEP 10: ADJUST SPRING TENSION

- ▶ Place  $\frac{3}{8}$ " diameter winding bar in tensioner ratchet wheel.
- ▶ Rotate winding bar in the down direction to increase spring tension. Each engagement of a tooth equals  $\frac{1}{8}$  turn.
- ▶ To decrease spring tension, pull down slightly on winding bar until pawl disengages tooth on tensioner ratchet wheel. Lift flange on pawl and move winding bar up until just past the pawl/tooth engagement. Allow pawl to rest on ratchet wheel and continue moving winding bar up until pawl is fully engaged with the tooth.
- ▶ Remove winding bar and operate door.
- ▶ Repeat steps above (If needed).

## WARNING!

COMPONENTS UNDER EXTREME SPRING TENSION COULD RESULT IN DEATH OR SERIOUS INJURY. ADJUSTMENTS MUST BE MADE BY TRAINED ROLLING DOOR TECHNICIANS USING PROPER TOOLS. DOOR MUST BE FULLY OPENED WHEN MAKING ADJUSTMENTS



## NOTE:

BRACKET SHOWN IS FOR ILLUSTRATION PURPOSES ONLY. ACTUAL BRACKET PROVIDED WILL VARY WITH DOOR SIZE. TENSIONER SYSTEM SHOWN ABOVE IS PROVIDED FOR ALL MINI BRACKET TYPES.

## NOTE:

LATCH SLIDE SLOT IN THE GUIDE MAY REQUIRE ADJUSTING AFTER DOOR INSTALLATION DUE TO VARIANCES IN MANUFACTURING AND/OR SITE CONDITIONS



## STEP 11: PRODUCT SAFETY LABELS

- ▶ Visual ✓ for RDD-201 on tension bracket. (page 11)
- ▶ Visual ✓ for RDD-204 on bottom bar. (page 11)
- ▶ Install RDD-202 door drive side, guide or jamb. (page 11)

## NOTE:

REQUIRES THESE PRODUCT SAFETY LABELS TO BE IN PLACE AND/OR INSTALLED TO FULLY COMPLETE INSTALLATION.

## PRODUCT SAFETY LABELS

<b>⚠ WARNING</b>

<p><b>Moving door could result in death or serious injury</b></p> <p><b>Do NOT close door until doorway is clear</b></p>
<b>SAFETY INSTRUCTIONS</b>
<ol style="list-style-type: none"> <li>1. Control the speed of the door during manual operation.</li> <li>2. Do not stand or walk under moving door.</li> <li>3. Keep doorway clear and in full view while operating door.</li> <li>4. Do NOT permit children to play on, near, or with door, or operate door controls.</li> <li>5. Unlock door before opening door.</li> <li>6. Sensing devices on motor operating doors should be tested frequently.</li> <li>7. Adjustments or repairs must ONLY be made by a trained door systems technician using proper tools and instructions.</li> <li>8. Visually inspect door and hardware monthly for worn and/or broken parts and check if door operates freely. DO NOT operate a door with a broken spring.</li> </ol>
<p>Place label at a readable height on door drive side guide or jamb.</p> <p>Do NOT remove, cover, or paint over label.</p> <p>This label should be inspected periodically for legibility, and a replacement label should be ordered from the door manufacturer as needed.</p>

<p>12/07 <span style="float: right;">RDD-202 ©</span></p>



RDD-202 Rolling Door Safety Label

RDD-201 Tension Safety Label

<b>⚠ WARNING</b>

<p><b>Components under extreme spring tension could result in death or serious injury.</b></p>
<b>SAFETY INSTRUCTIONS</b>
<ol style="list-style-type: none"> <li>1. Repairs and adjustments must be made by a trained rolling door systems technician using the proper tools and instructions.</li> <li>2. Door must be fully opened when making adjustments.</li> </ol>
<p>Do NOT remove cover or paint over label.</p> <p>This label should be inspected periodically for legibility, and a replacement label should be ordered from the door manufacturer as needed.</p>

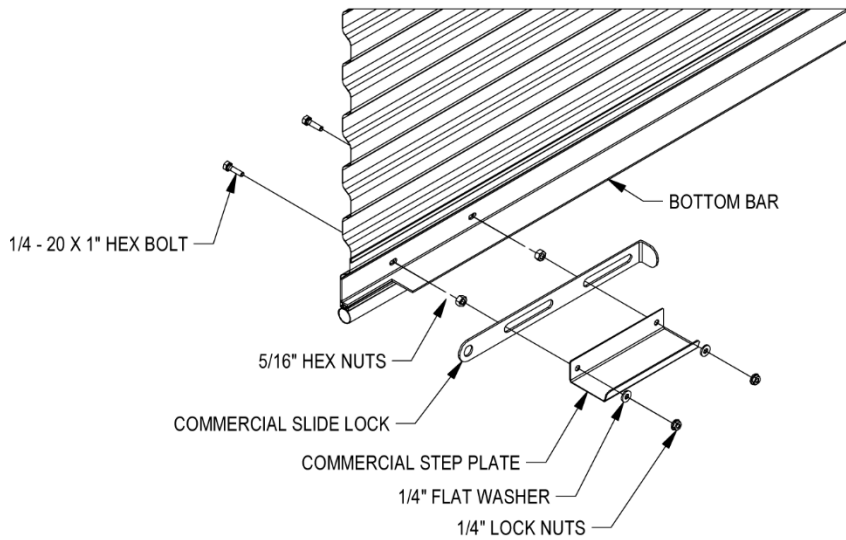
<p>12/07 <span style="float: right;">RDD-201 ©</span></p>
<p>Order # _____</p>

<b>⚠ WARNING</b>	<b>SAFETY INSTRUCTIONS</b>	<ol style="list-style-type: none"> <li>4. Do NOT permit children to play on, near, or with door, or operate door controls.</li> <li>5. Unlock door before opening door.</li> <li>6. Sensing devices on motor operated doors should be tested frequently.</li> </ol>	<ol style="list-style-type: none"> <li>7. Adjustments or repairs must ONLY be made by a trained door systems technician using proper tools and instructions.</li> <li>8. Visually inspect door and hardware monthly for worn and/or broken parts and check if door operates freely. DO NOT operate a door with a broken spring.</li> </ol>	<p>Attach label to bottom bar.</p> <p>Do NOT remove, cover, or paint over label.</p> <p>This label should be inspected periodically for legibility, and a replacement label should be ordered from the door manufacturer as needed.</p>	
<p style="text-align: center;"></p> <p><b>Moving door could result in death or serious injury.</b></p> <p><b>Do NOT close door until doorway is clear.</b></p>	<ol style="list-style-type: none"> <li>1. Control the speed of the door while manually operating.</li> <li>2. Do not stand or walk under moving door.</li> <li>3. Keep doorway clear and in full view while operating door.</li> </ol>	<p>12/07 <span style="float: right;">RDD-204 ©</span></p>			

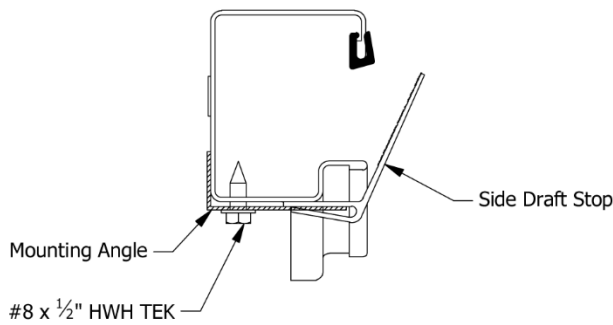
RDD-204 Rolling Door Bottom Bar Label

- ▶ requires the following product safety labels to be in place and/or installed to fully complete installation.
- ▶ Any case where product safety labels are missing or damaged, contact immediately to obtain replacements.

# OPTIONAL SLIDE LOCK & TOP/SIDE DRAFT STOP

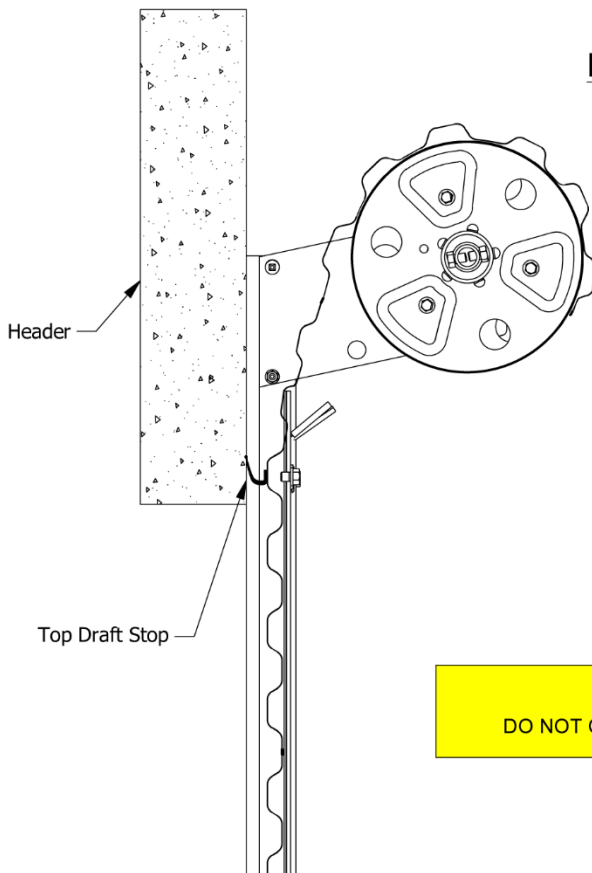


**FIGURE 16:  
OPTIONAL BOTTOM BAR  
MOUNTED SLIDE LOCKS**



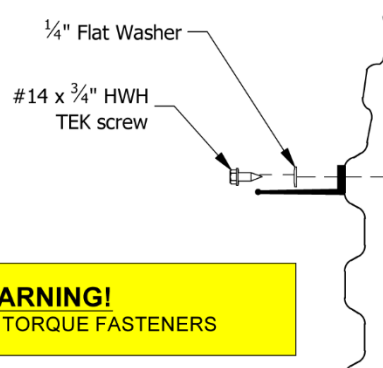
**FIGURE 17: SIDE DRAFT STOP INSTALLATION**

- ▶ Attach draft stop & angle flush with guide using #8 x 1/2" HWH Tek.



**FIGURE 18: TOP DRAFT STOP INSTALLATION**

- ▶ With door fully closed, mark curtain for draft stop mounting location.
- ▶ Raise curtain until mounting location is accessible.
- ▶ Attach top draft stop to curtain every 12" using #14 x 3/4" HWH TEK screws and flat washers.



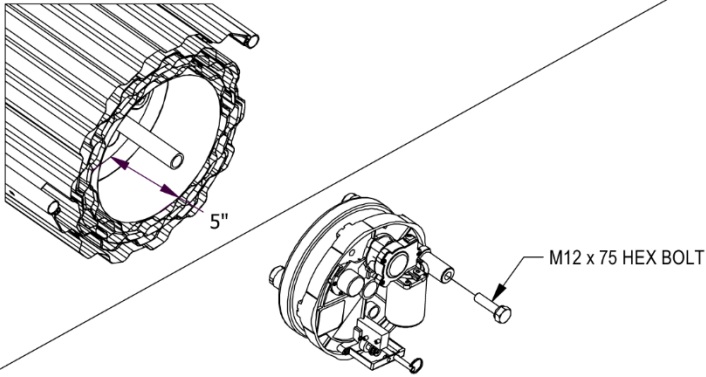
**WARNING!**  
DO NOT OVER TORQUE FASTENERS

# OPTIONAL JSS PANTHEON INSTALLATION

**NOTE:**  
CONNECTING THE MANUAL RELEASE CABLE TO DRIVE HEAD IS TO BE DONE BEFORE DOOR IS INSTALLED

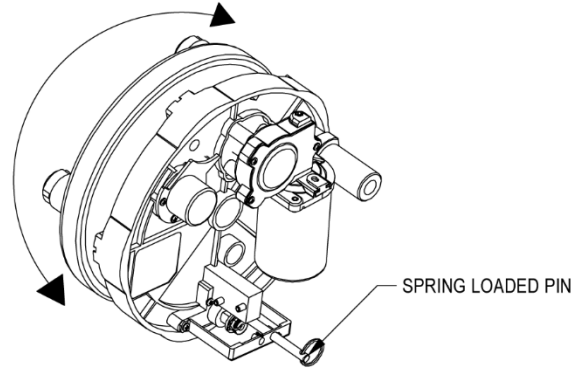
## STEP 1

CHECK FOR 5" INSET AND REMOVE BOLT FROM DRIVE HEAD



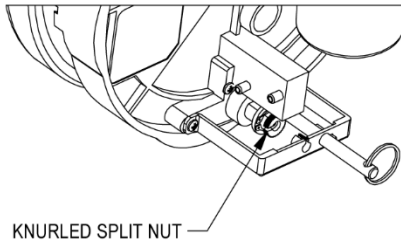
## STEP 2

PULL RING ON SPRING LOADED PIN & ROTATE MOTOR HEAD



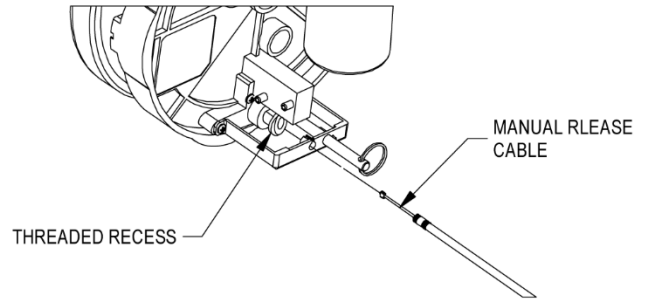
## STEP 3

REMOVE THE KNURLED SPLIT NUT



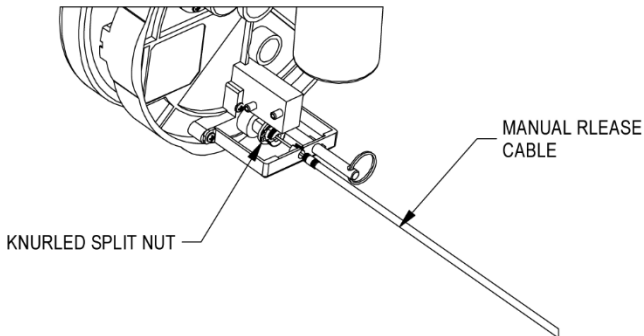
## STEP 4

INSERT MANUAL RELEASE CABLE INTO THREADED RECESS



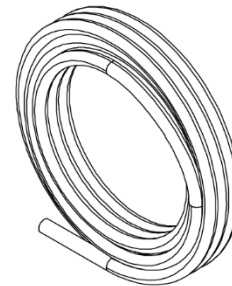
## STEP 5

REINSTALL KNURLED SPLIT NUT & TIGHTEN



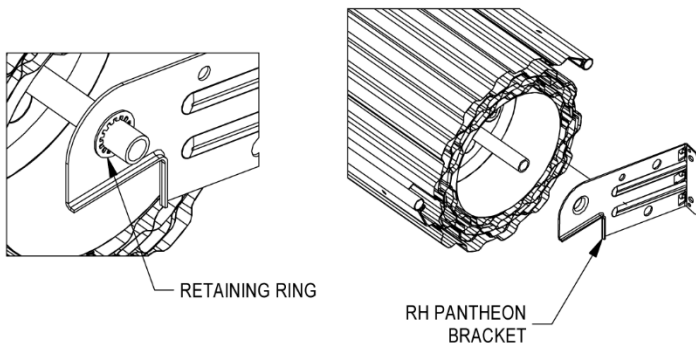
## STEP 6

COIL RELEASE CABLE AND MOTOR ELETRIC CABLES



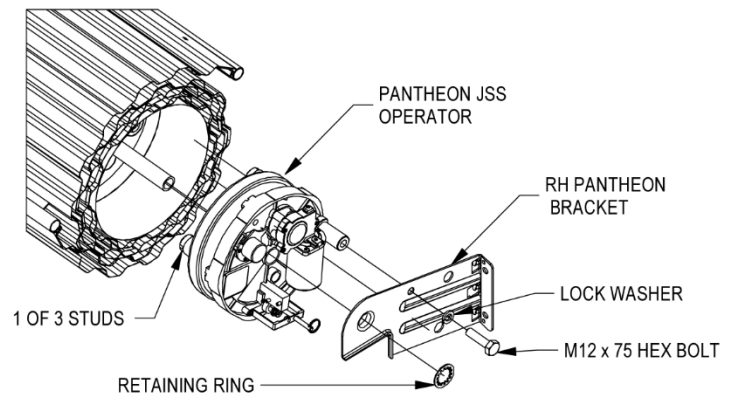
## STEP 7

REMOVE RIGHT HAND PANTHEON BRACKET



## STEP 8

INSTALL DRIVE UNIT



## OPTIONAL ELECTRIC OPENER INSTALLATION

**NOTE:**

CONNECTING THE MANUAL RELEASE CABLE TO DRIVE HEAD IS TO BE DONE BEFORE DOOR IS INSTALLED

**WARNING!**

TAKE CARE TO ENSURE THAT THE CABLES FROM THE DRIVE UNIT ARE NOT DAMAGED OR PERMITTED TO RUB ON ANY PART OF THE STRUCTURE OR THE DOOR DURING THE INSTALLATION.

**NOTE:**

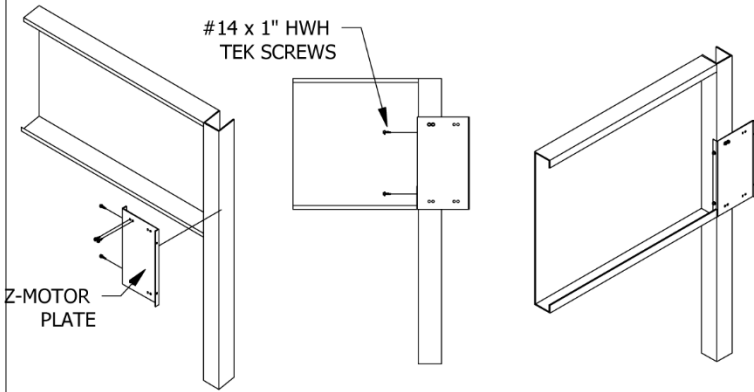
FOR THE COMPLETE INSTRUCTIONS ON INSTALLING AND SETTING UP THE PANTHEON MOTOR, PLEASE REFERENCE THE PANTHEON INSTRUCTIONS FOR FURTHER DETAILS.

- ▶ Step 1: Check to ensure 5" inset on the barrel is present. Remove bolt from drive head.
  - ▶ Step 2: Pull ring on spring loaded pin and twist to disengage auto (electric mode). Rotate motor head in both directions to test manual operation.
  - ▶ Step 3: Remove the knurled split nut.
  - ▶ Step 4: Uncoil the manual release cable and insert the free end of the cable into the threaded recess where the knurled split nut was removed.
  - ▶ Step 5: Reinstall knurled split nut and tighten.
  - ▶ Step 6: Carefully coil release cable and motor electric cables together and secure to each other in order to prevent uncoiling or damage during installation of the door.
  - ▶ Step 7: Remove right hand Pantheon bracket from end of door.
  - ▶ Step 8: Place the drive unit inside the door drum assembly and verify the three (3) studs on the back of the drive unit are fully engaged in the three (3) holes on the steel drum wheel.
- 
- ▶ Return to page 8 to continue installation.

# OPTIONAL ATA EZ-ROLLER INSTALLATION

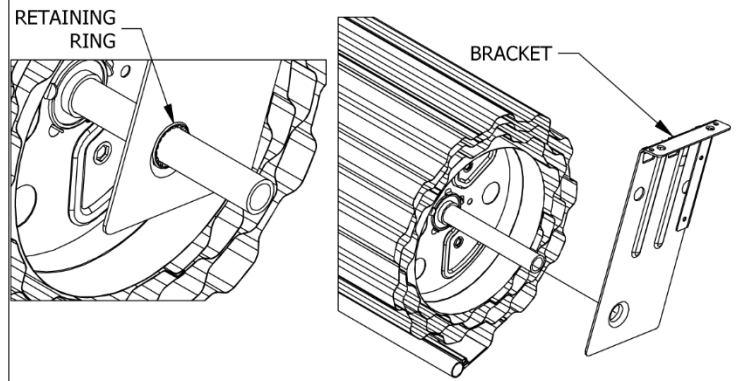
## STEP 1

INSTALL Z-MOTOR PLATE (OPTIONAL)



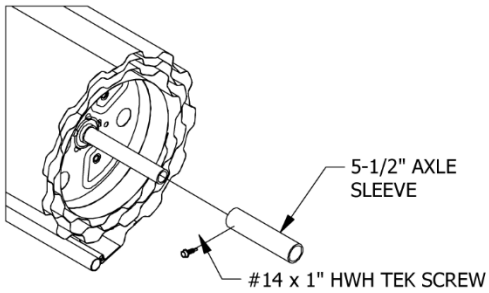
## STEP 2

CUT RETAINING RING & REMOVE BRACKET



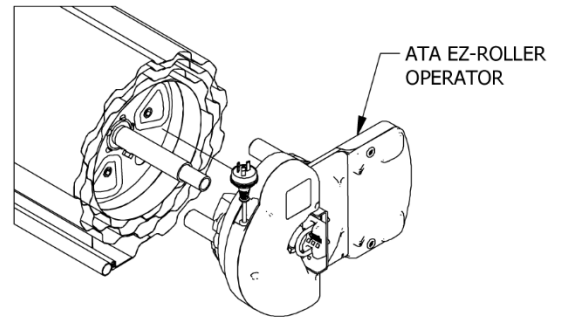
## STEP 3

INSTALL AXLE SLEEVE



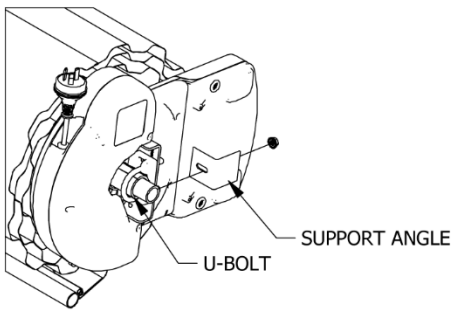
## STEP 4

INSTALL ATA EZ-ROLLER



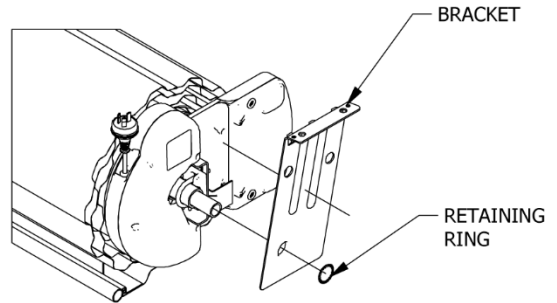
## STEP 5

INSTALL SUPPORT ANGLE



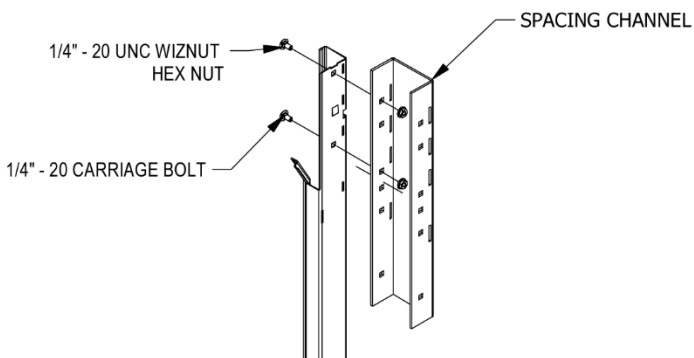
## STEP 6

INSTALL BRACKET



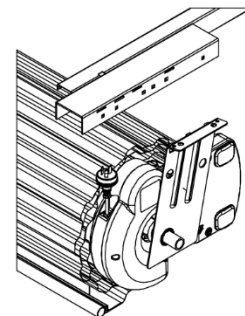
## STEP 7

INSTALL SPACING CHANNEL

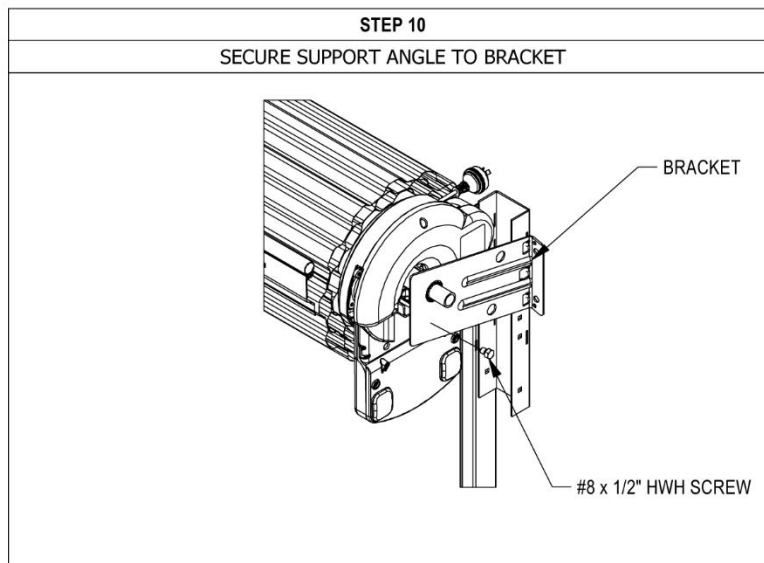
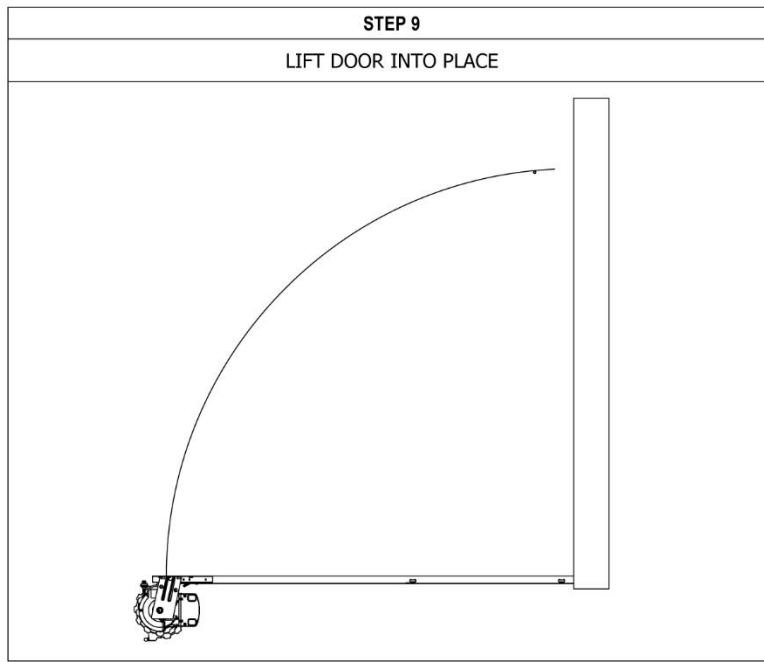


## STEP 8

INSTALL SPACING CHANNEL & GUIDE TO BRACKET



# OPTIONAL ROLLER INSTALLATION (CONT.)



- ▶ Step 1: Install the Z-Motor Plate using Min. 3 - #14 x 1 HWH TEK screws.
- ▶ Step 2: Cut retaining ring on axle and discard. Remove bracket and save for later use.
- ▶ Step 3: Slide axle sleeve onto axle and secure with #14 x 1" HWH TEK screw
- ▶ Step 4: Slide Roller onto axle shaft until both prongs enter the drum.
- ▶ Step 5: Install Support Angle onto the front leg of the U-Bolt.
- ▶ Step 6: Install bracket and new retaining ring onto axle until the bracket is flush with the face of the Roller.
- ▶ Step 7: Install Spacing channel onto Guide.
- ▶ Step 8: Attach spacing channel/guide assembly to bracket.
- ▶ Step 9: Return to **step 4** on **page 8** to continue installation (See Step 10 before returning to **step 4** on **page 8**).
- ▶ Step 10: Secure the Support Angle to the Bracket, using the #8 x 1/2" HWH Screw..

# Operation and Maintenance

The following manual is provided to evaluate the operational performance and future maintenance of Rolling Sheet door product line. mandates rolling sheet door product installation by trained rolling door technicians and future maintenance by experienced/qualified personnel. Specific parts, components, assemblies, etc. that are determined to be defective, worn or unsafe by performance evaluations or preventative maintenance programs must result in rolling sheet door assembly taken out of service. All repairs, part replacements or adjustments must be made by trained rolling door technicians to place rolling sheet door assembly back into service. It is **MANDATORY** that all door technicians and other technicians, installers and future maintenance staff comply fully with all safety information, procedures and instructions contained in this manual. **Failure to do so could result in premature part/component failure resulting in serious injury or death to others** and, with respect to door technicians, immediate termination of employment

**Adjustments, part replacement, repairs, etc. must be performed by trained rolling door technician**

## ROLLING SHEET DOOR PERFORMANCE EVALUATION

- Rolling Door operation should be easy at/near the open and closed positions. Rolling Door may require more effort to open through the middle portion of travel.
- Rolling Door operation to the open position should result in bottom bar angle resting against head stops and remain in the open position.
- Rolling Door operation should not exceed 35lb. of force for hand chain operation, and 30 lb. for manual operation.
- Rolling Door operational balance evaluation:  
*If door operation is easy to close, but hard to open; spring tension needs to be increased*  
*If door operation is hard to close, but easy to open; spring tension needs to be decreased*  
**Spring tension adjustments must be made by trained rolling door technician. Refer to Rolling Door installation instructions for tension adjustment procedure.**

### ▲ **WARNING: Extreme spring tension can cause serious injury or death** ▲

- Rolling Door electrical motor operation should be evaluated quarterly.
- Prior to Rolling Door electrical motor operation ensure that doorway is clear and in full view before and during complete operation cycle.
- UL 325 requires constant pressure to close for doors without sensing edges or photoelectric sensors/eyes.
- Sensing devices should be tested at least weekly. Sensing edges should be tested at both ends to evaluate proper operation. Photoelectric eyes must be tested by breaking beam to evaluate proper operation.
- Evaluate operator limit setting at door travel open and closed positions. If operator limit setting has become out of sync with door open and close positions, refer to operator installation instructions to reset limits to an appropriate setting in relationship to door open and closed positions.
- If at any time during Rolling Door electrical motor operation, motor sounds like it is under excessive load or stress to open the door:
  - ▲ Close door using motor operator. Engage motors manual operation feature to manually operate the door to the open position.
  - ▲ If door operation is heavy, cannot be completely opened or hard to open and will not stay in open position; Spring Assembly counterbalance evaluation is required, which may require adjustment or replacement.
  - ▲ **Spring tension adjustments or repairs must be made by trained rolling door technician. Refer to Rolling Door installation instructions for tension adjustment procedure.**
  - ▲ **Determination of counterbalance repair must result in Rolling Door taken out of service until required repairs are complete.**

## **VISUAL INSPECTION**

### **Guides:**

- Guide fasteners must be present and secured in each existing hole/slot provided with fasteners supplied
- Guides must not be bent, crushed, or damaged in a way that binds the curtain and/or bottom bar assembly at any portion of travel.
- Head stops must be securely fastened in place at top of guide to prevent bottom bar from traveling out of the top of the guides when rolling door curtain is fully raised to the open position.
- Inspect guide wear strip (when provided) for excessive cracking, tearing, wear or absence.

### **Curtain:**

- During rolling door operation, curtain and bottom bar assembly must move freely inside guides and not contact header or ceiling.
- Latches, Step Plates, Slidelocks, Windlocks, etc. (when provided) must always be securely fastened to curtain assembly.
- **Windlocks should never be removed from curtain.**
- Inspect curtain wear material or felt tape (when provided) for excessive tearing, wear or absence.
- Inspect weather seals; Top Draft Stop, Side Draft Stop, Brush (when provided)

### **Brackets/Mounting Plates:**

- All fasteners must be present and secured with fasteners detailed in installation instructions.
- Brackets & Mounting Plates (when provided) must not be bent or damaged in a way that adversely effects the safe operation of door assembly.

### **Hood Assembly:**

- When provided, all fasteners attaching hood endcaps, hood support (when provided) and hood to wall must be secure.
- Hood endcaps or hood must not be bent or crushed in a manner which binds the curtain thus hindering the proper operation of rolling door operation.

### **Tensioning Devices & Axle Supports:**

- Fasteners attaching all tensioning devices and axle supports must be securely fastened.
- Set screws securing axle must be securely fastened.
- Inspect for components for damage or deformity.

**▲Determination of tensioning device repair or replacement must result in Rolling Door taken out of service until required repairs are complete. Repair or replacement must be performed by trained rolling door technician**

**▲Product safety labels should be periodically inspected and cleaned by the product user as necessary to maintain good legibility for safe viewing distance**

**Product safety labels should be replaced by the product user when they no longer meet the legibility requirements for safe viewing distance. In any case where products have an extensive expected life or where exposed to extreme conditions, the product user should immediately contact to obtain replacements.**