

VG

MEGAN GALAS

BUFFALO TO NEW YORK CITY

I was born and raised in Buffalo, New York with big city dreams.

I attended the Fashion Institute of Technology and graduated with a BFA in Visual Presentation and Exhibition Design, an AAS in Communication Design, and a minor in Art History.

HOW I BEGAN MY CAREER

Immediately upon graduating in 2018, I was hired by a small NYC design firm. At RPG, I began to design retail merchandising point of purchase displays.

Within a few months, I was presented with an opportunity to join the Marc Jacobs Global Visual Merchandising and Store Design team. At Marc Jacobs, I had hands on experience in each stage of the design process. It extended from concept and design development, to 3D modeling and renderings, to production and installation.

In 2020 when the pandemic hit, I moved back to my hometown of Buffalo. I began to refine my technical skill set and became a Drafter at Boston Valley Terra Cotta. Soon later I joined Hadley Exhibits as a 3D Designer creating trade shows and museums. Now, I continue to push the boundaries of creativity in the exhibit world while learning about how exhibits are constructed.

WHAT I CAN DELIVER

What I can deliver is an extraordinary skill set with a sense of creativity. My strength lies within the design of immersive brand experiences and the ability to bring them to life through 3D modeling, rendering, floor plans, elevations, graphics, materials, and concept boards.

I thrive in a fast-paced environment and can communicate, meet deadlines, and deliver design concepts on a consistently high-end level.

I am a passionate, hard-working team player who leads by example and is always looking for something new to learn.

NEW YORK CITY TO BUFFALO

During the pandemic, I chose to leave NYC and make Buffalo my home again. Today, I am looking for a new opportunity to continue to do what I love from the city that is my home.

I believe I can make a creative impact and bring a multitude of skills that can enhance your team. Please find below a few examples of my work. For additional work visit megdesign.info. If you have any questions feel free to contact me at any time.

Phone: 716.479.5881

Email: megangalas@megdesign.info

Website: megdesign.info

BUFFALO BILLS CONTAINER BAR - BUFFALO, NY

PACKAGE 1
8 PANELS

- (4) 88" x 10" Panel
- (4) 111" x 31.75" Panel

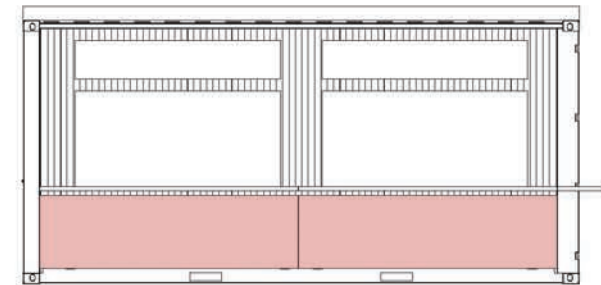
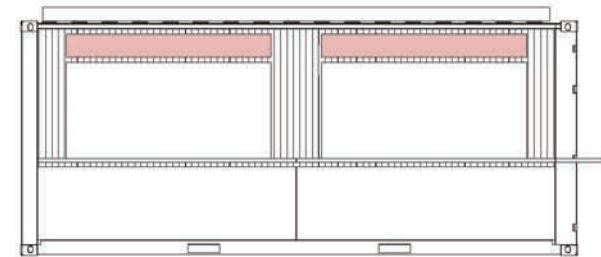
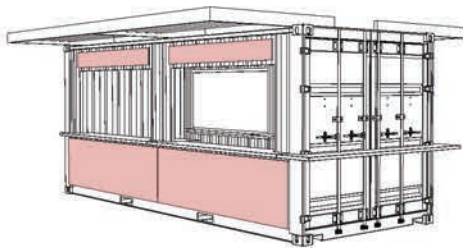
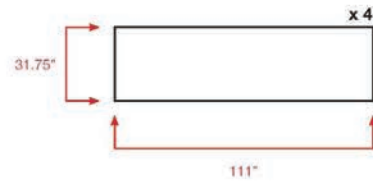
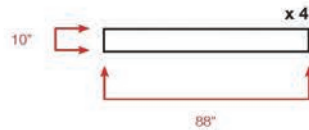

BUFFALO BILLS CONTAINER BAR - BUFFALO, NY



PEANUTS X THE MARC JACOBS - AVENTURA, FL



PEANUTS X THE MARC JACOBS - AVENTURA, FL



THE MARC JACOBS TAG TOTE - GLOBAL ROLLOUT 2020



MARC JACOBS FALL 18' AT DOVER STREET MARKET - NEW YORK, NY



MARC JACOBS FALL 18' AT DOVER STREET MARKET - NEW YORK, NY

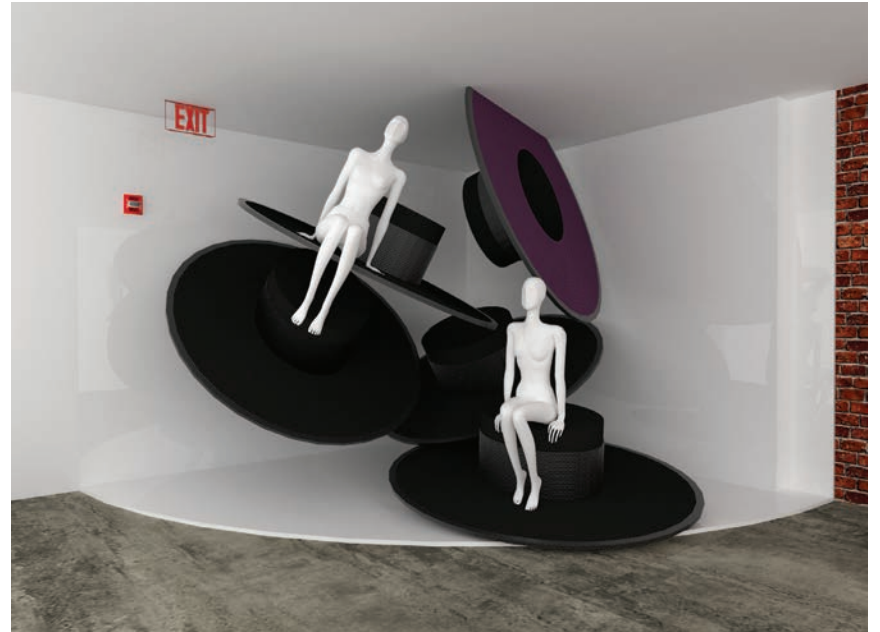

MARC JACOBS SPRING 18' AT PRINCE STREET - NEW YORK, NY



MARC JACOBS SPRING 18' AT PRINCE STREET - NEW YORK, NY



THE MARC JACOBS POP UP - KLCC, MALAYSIA

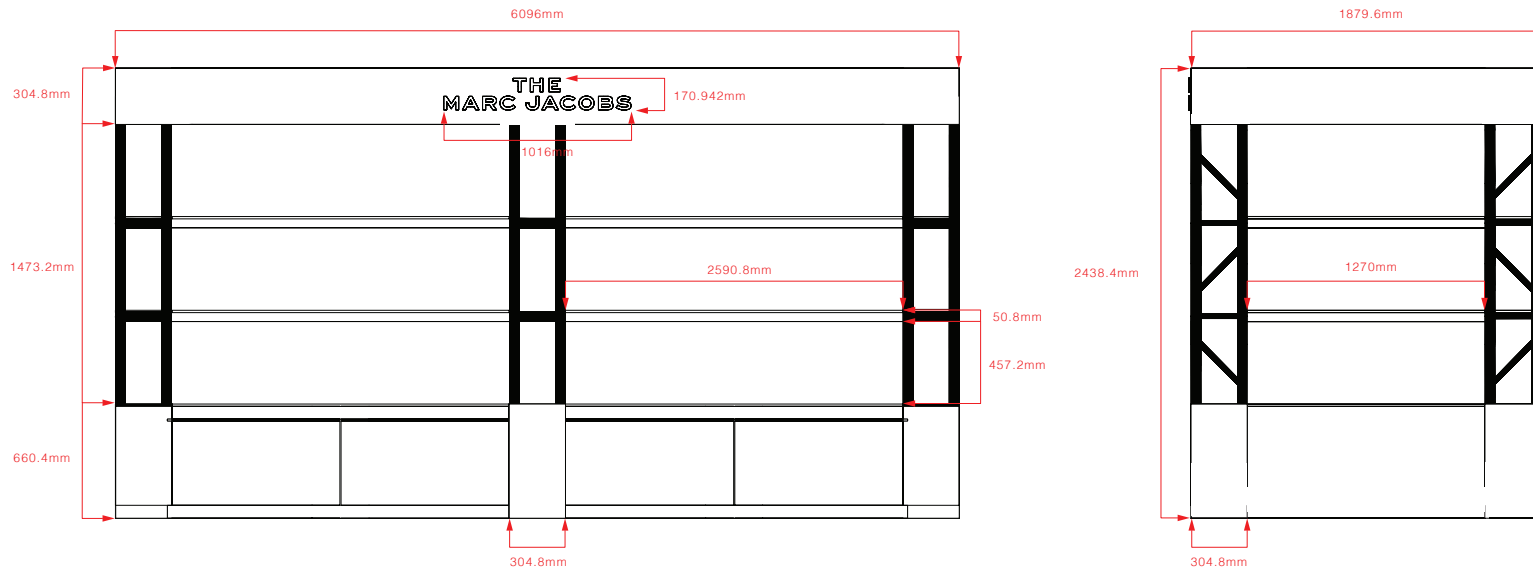

THE MARC JACOBS POP UP - KLCC, MALAYSIA



THE MARC JACOBS - HANAM STARFIELD, KOREA



THE MARC JACOBS - HANAM STARFIELD, KOREA



THE MARC JACOBS - ELEMENTS, HONG KONG



THE MARC JACOBS - ELEMENTS, HONG KONG



THE MARC JACOBS FIXTURES - GLOBAL ROLLOUT

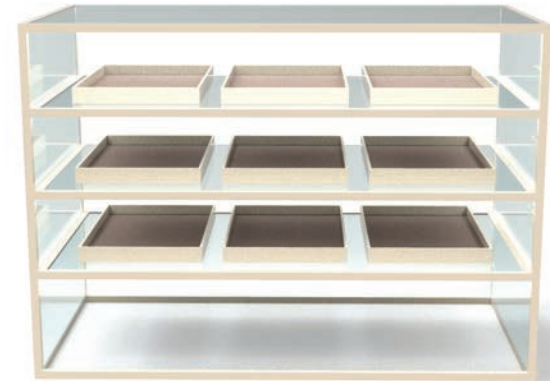

MARC JACOBS CASH WRAP SPECIFICATIONS

SPECIFICATIONS

Notes:

- Please note this is general direction.
- The bottom cabinet must hold the power and network quads.
- The trash can will be located inside the bottom cabinet

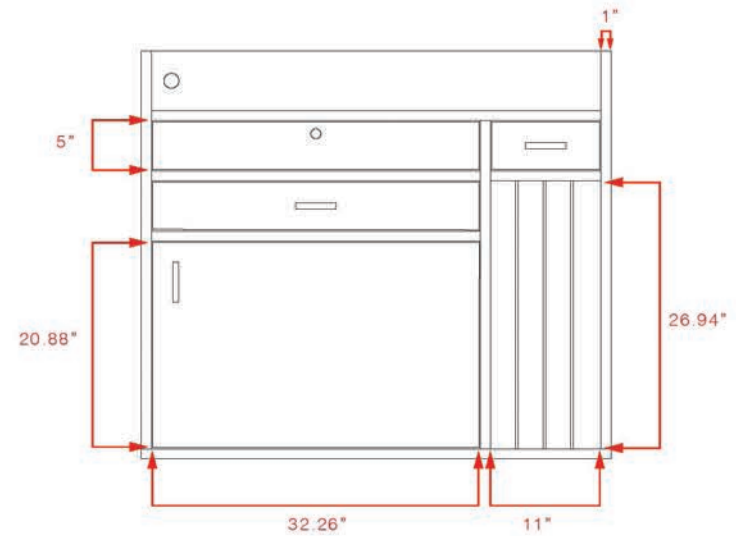
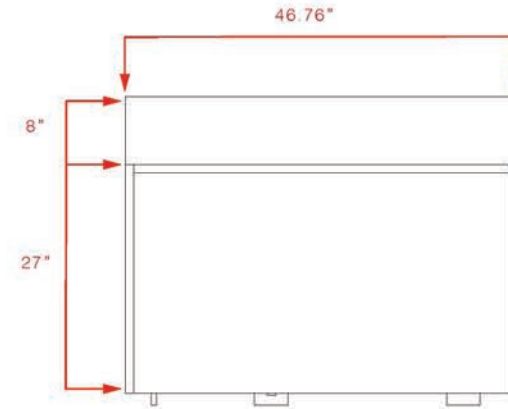
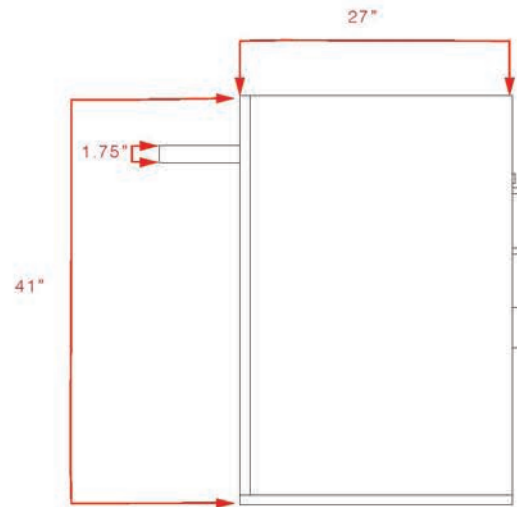

MARC JACOBS CASH WRAP SPECIFICATIONS

CALLOUTS

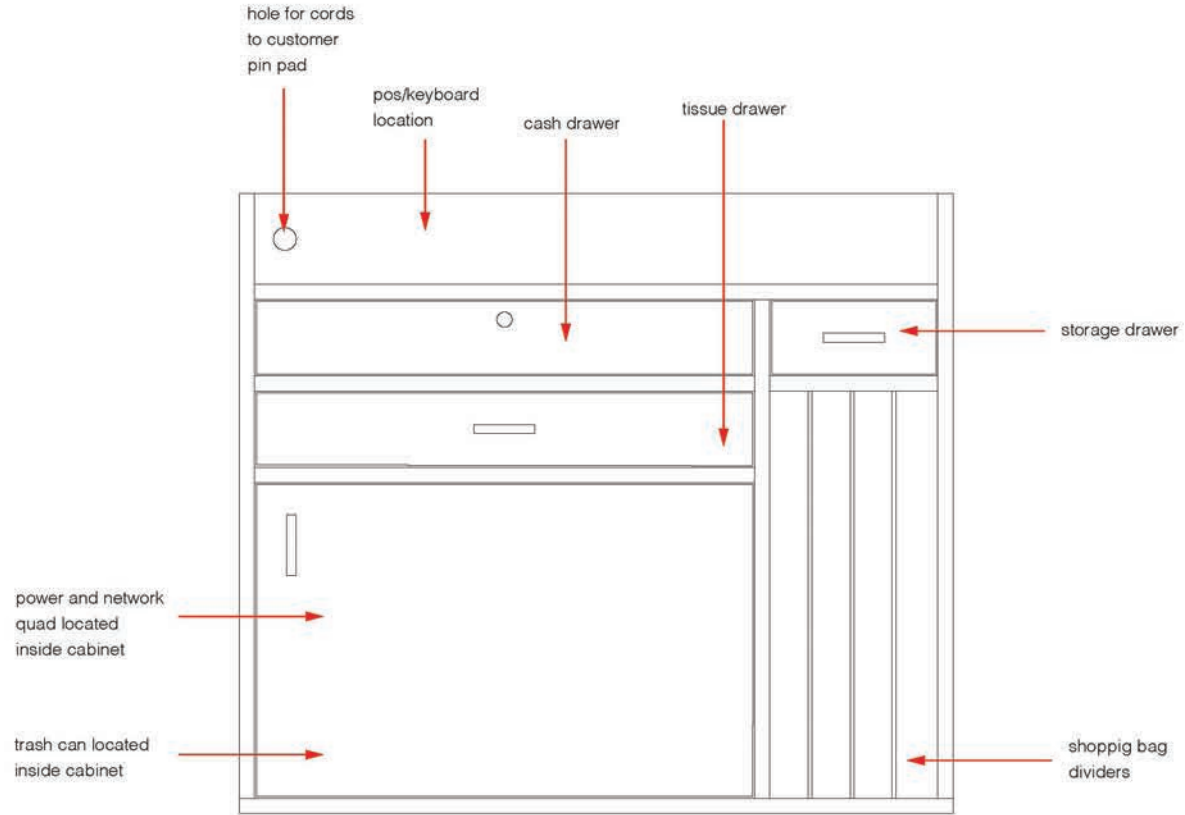

BYRIDER NADA 22' SHOW CONCEPT DESIGN



BYRIDER NADA 22' SHOW CONCEPT DESIGN

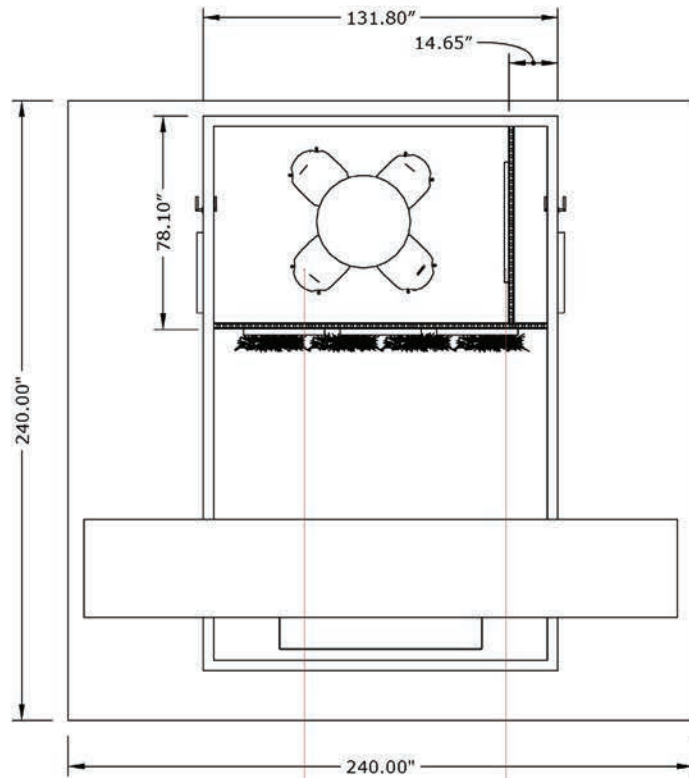

Cort Events
Rental - Table &
Chairs

55" Monitor



BYRIDER NADA 22' SHOW CONCEPT DESIGN

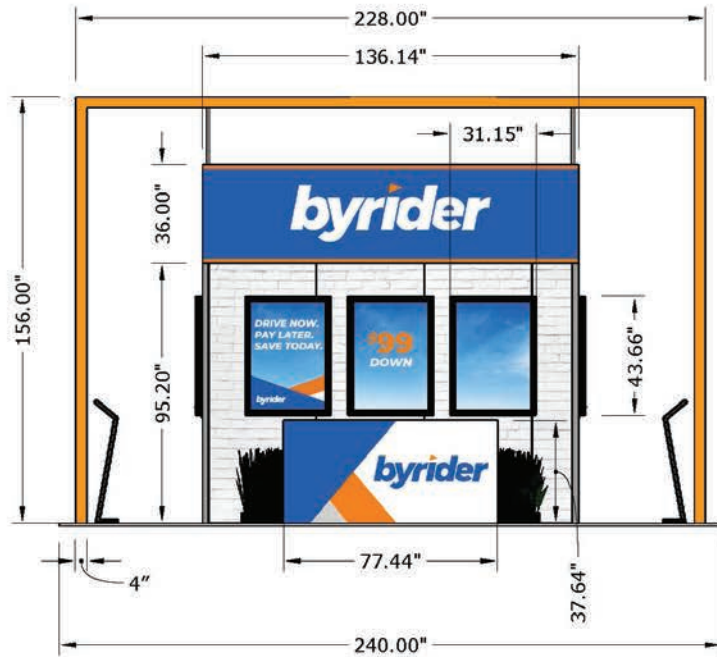

Booth Front Elevation
Option 1

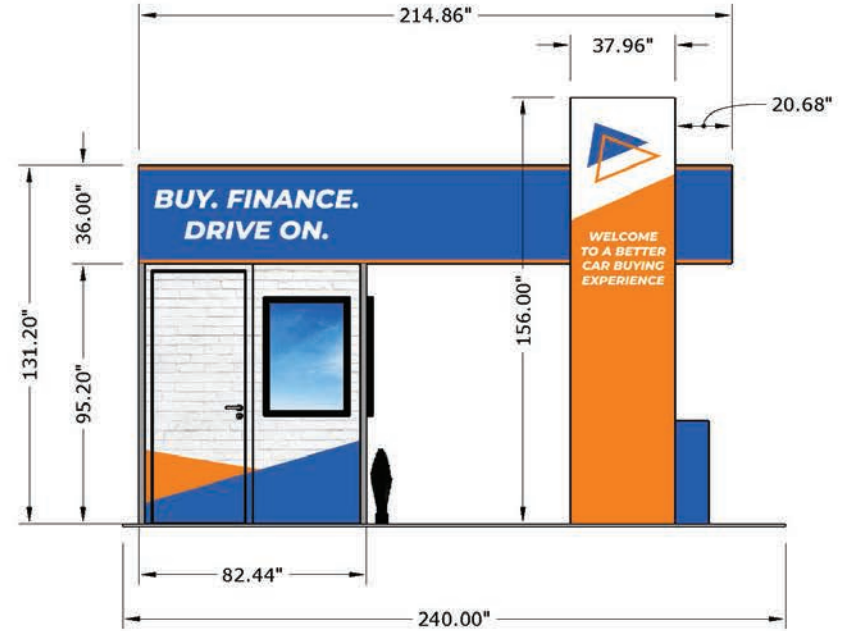

Booth Side Elevation
Option 1

QTRAN NEW BOOTH CONCEPT DESIGN



QTRAN NEW BOOTH CONCEPT DESIGN

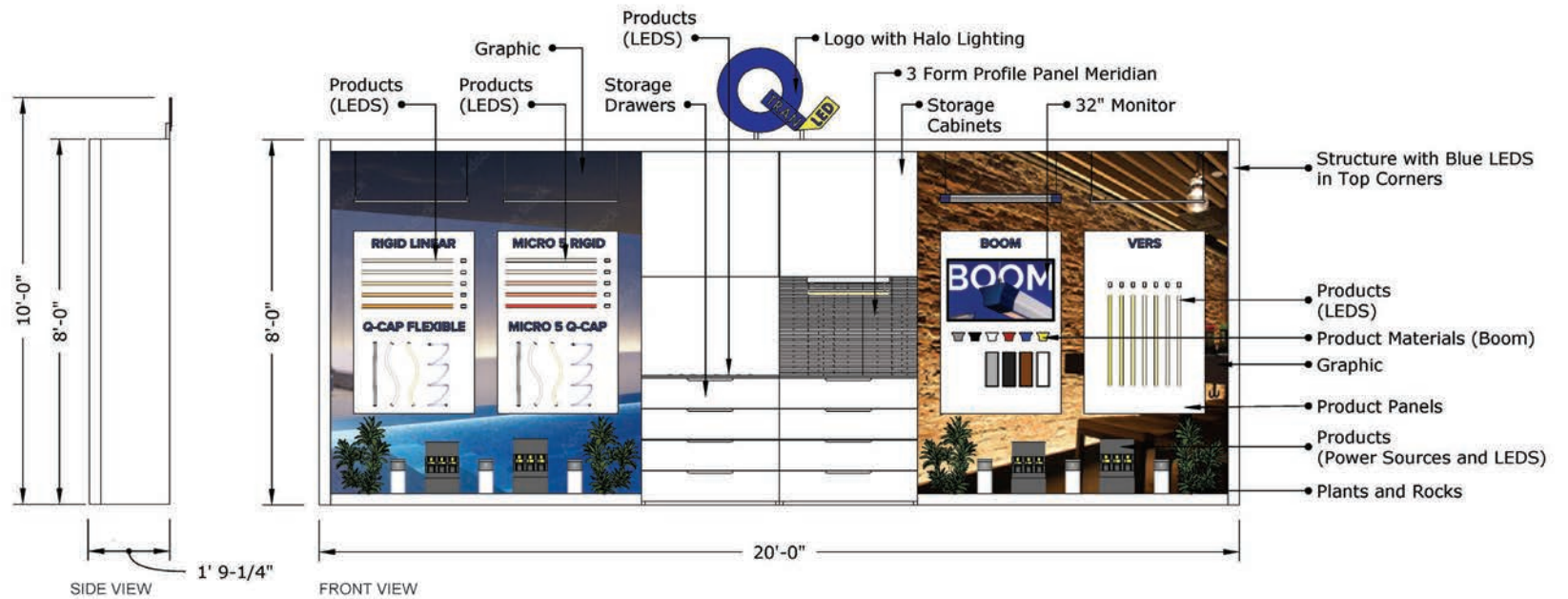

THE BUFFALO HISTORY MUSEUM RESOURCE CENTER - BUFFALO, NY



THE BUFFALO HISTORY MUSEUM RESOURCE CENTER - BUFFALO, NY

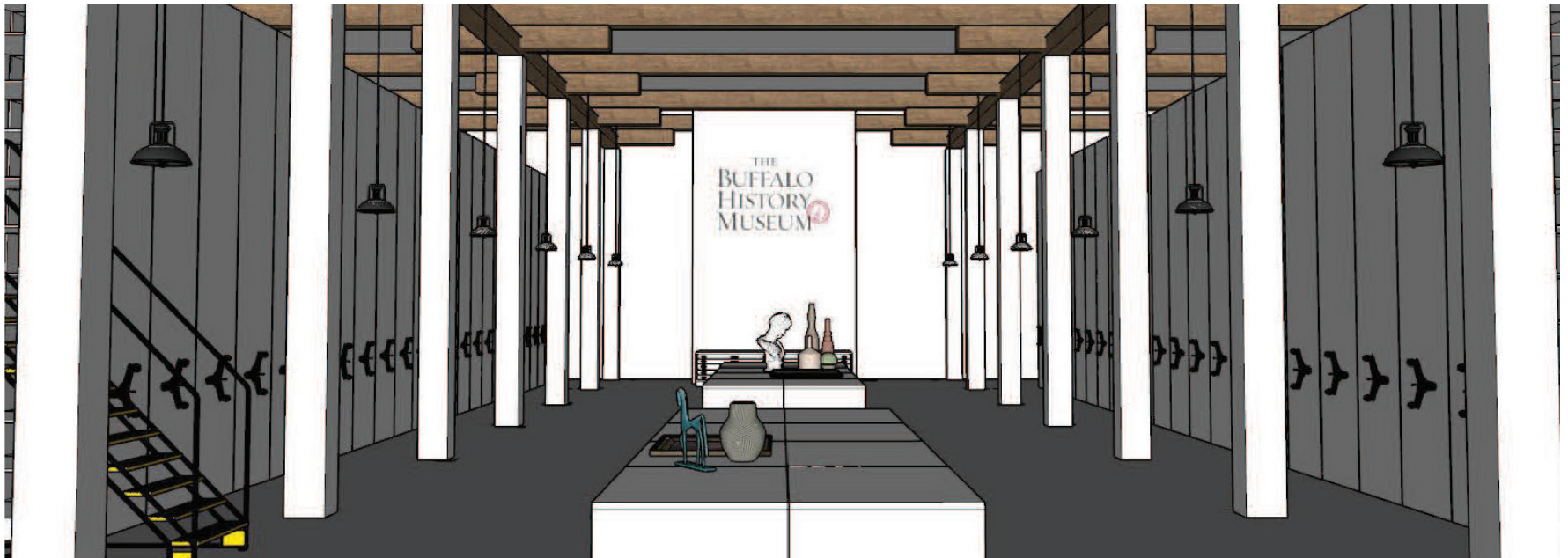

LAKE PLACID OLYMPIC MUSEUM - LAKE PLACID, NY



LAKE PLACID OLYMPIC MUSEUM - LAKE PLACID, NY



LAKE PLACID OLYMPIC MUSEUM - LAKE PLACID, NY



ESSIE AN EXPLOSION OF COLOR



ESSIE AN EXPLOSION OF COLOR

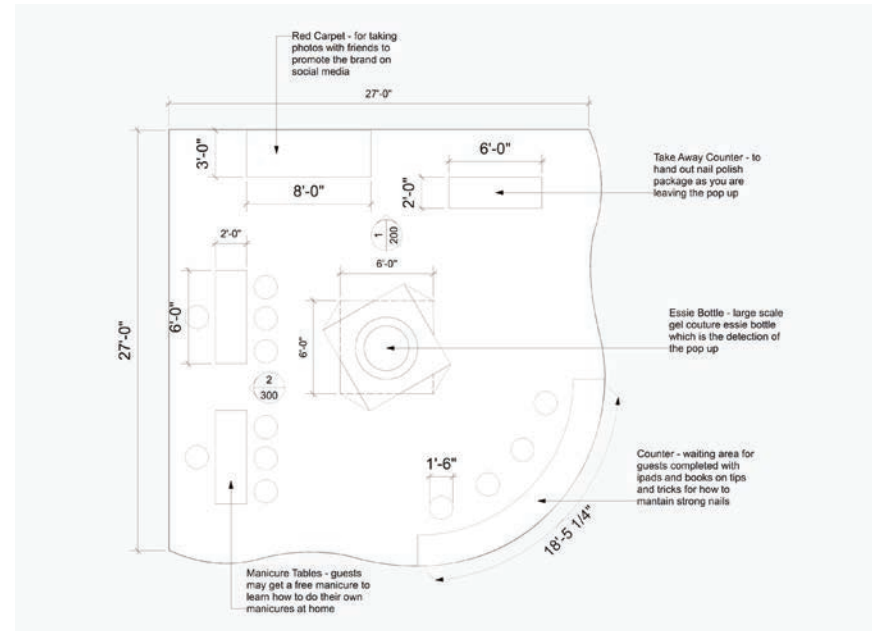
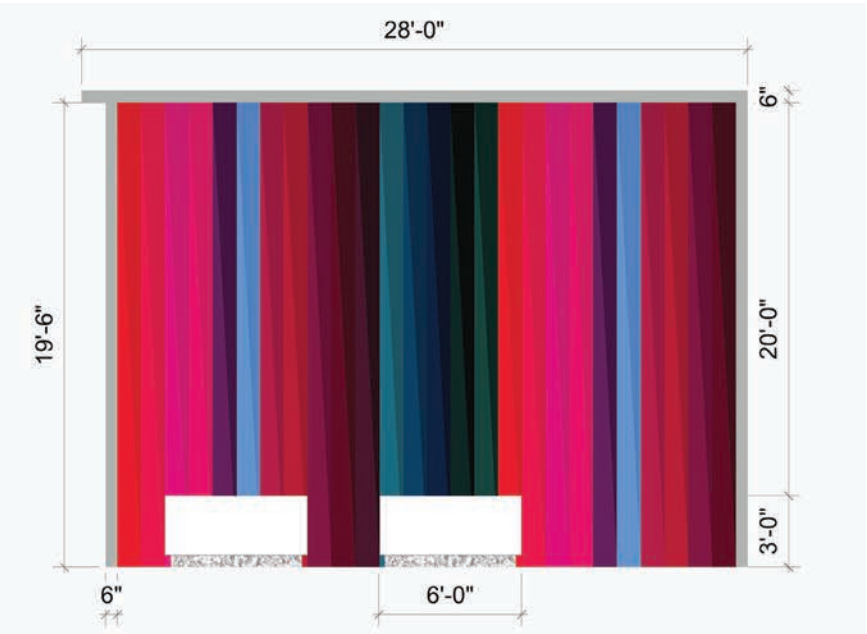
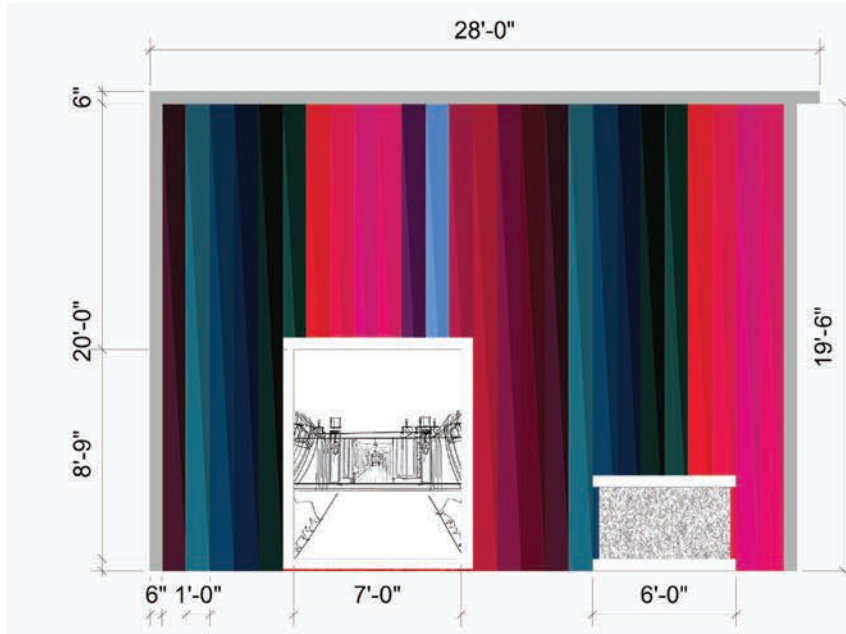

Phone: 716.479.5881

Email: megangalas@megdesign.info

Website: megdesign.info

