

A photograph of a person's hands holding a smartphone, overlaid with a semi-transparent red filter. The person is wearing a light-colored, textured sweater. The background is a solid red color.

Table of Contents for Lin Commercial Boilers

High-End Lifestyle Water Management Service

Once having experienced the vast ocean, no other water can compare; except for the clouds over Wushan, no other clouds can rival. Pursue a truly meaningful life. Not even a cup of water will be compromised.

K1-S20 Step Water Heater (Single Hot Bar Machine)

Product Parameter :

- 1、 Rated power: 2210W
- 2、 Rated voltage: 220V
- 3、 Rated frequency: 50Hz
- 4、 Rated capacity: 7.8L
- 5、 Water output: 20L/h
- 6、 Product dimensions: 190*250*600 mm
- 7、 Package size: 280*410*680 mm



K 1-S30 Step-by-Step Water Heater (Single Hot Water Bar)

Product Parameter :

- 1、 Rated power: 3000W
- 2、 Rated voltage: 220V
- 3、 Rated frequency: 50Hz
- 4、 Rated capacity: 9.8L
- 5、 Water output: 30L/h
- 6、 Product dimensions: 190*250*660 mm
- 7、 Package size: 280*410*725 mm



K2-S20 Step-by-Step Water Heater (Single Hot Water Bar)

Product Parameter

- 1、Rated power: 2210W
- 2、Rated voltage: 220V
- 3、Rated frequency: 50Hz
- 4、Rated capacity: 7.8L
- 5、Water output: 20L/h
- 6、Product dimensions: 190*250*600 mm
- 7、Package size: 280*410*680 mm



K2-S30 Step-by-Step Water Heater (Single Hot Water Bar)

Product Parameter :

- 1、 Rated power: 3000W
- 2、 Rated voltage: 220V
- 3、 Rated frequency: 50Hz
- 4、 Rated capacity: 9.8L
- 5、 Water output: 30L/h
- 6、 Product dimensions: 190*250*660 mm
- 7、 Package size: 280*410*725 mm



K9-20 progressive water heater (single hot bar)

Product Parameter

- :
- 1、 Rated power: 2210W
 - 2、 Rated voltage: 220V
 - 3、 Rated frequency: 50Hz
 - 4、 Rated capacity: 7.8L
 - 5、 Water output: 20L/h
 - 6、 Product dimensions: 190*250*600 mm
 - 7、 Package size: 280*410*680 mm

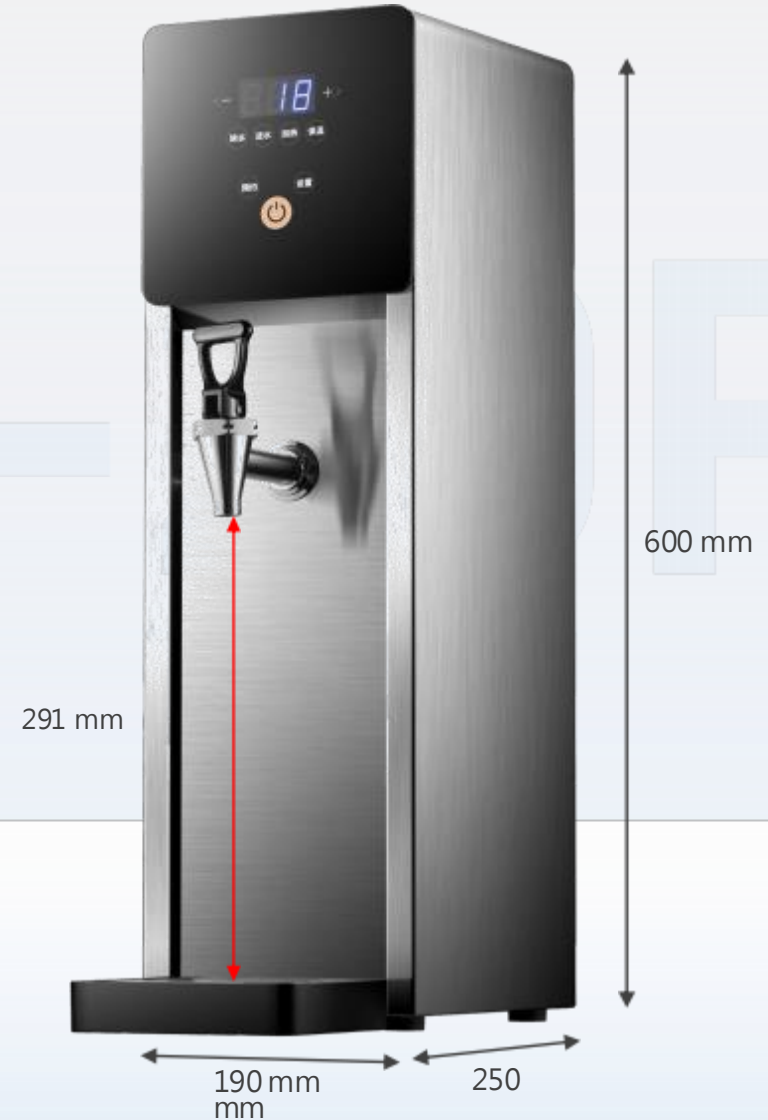

K9-30 Stepping Water Heater (Single Hot Bar Machine)

Product Parameter :

- 1、 Rated power: 3000W
- 2、 Rated voltage: 220V
- 3、 Rated frequency: 50Hz
- 4、 Rated capacity: 9.8L
- 5、 Water output: 30L/h
- 6、 Product dimensions: 190*250*660 mm
- 7、 Package size: 280*410*725 mm

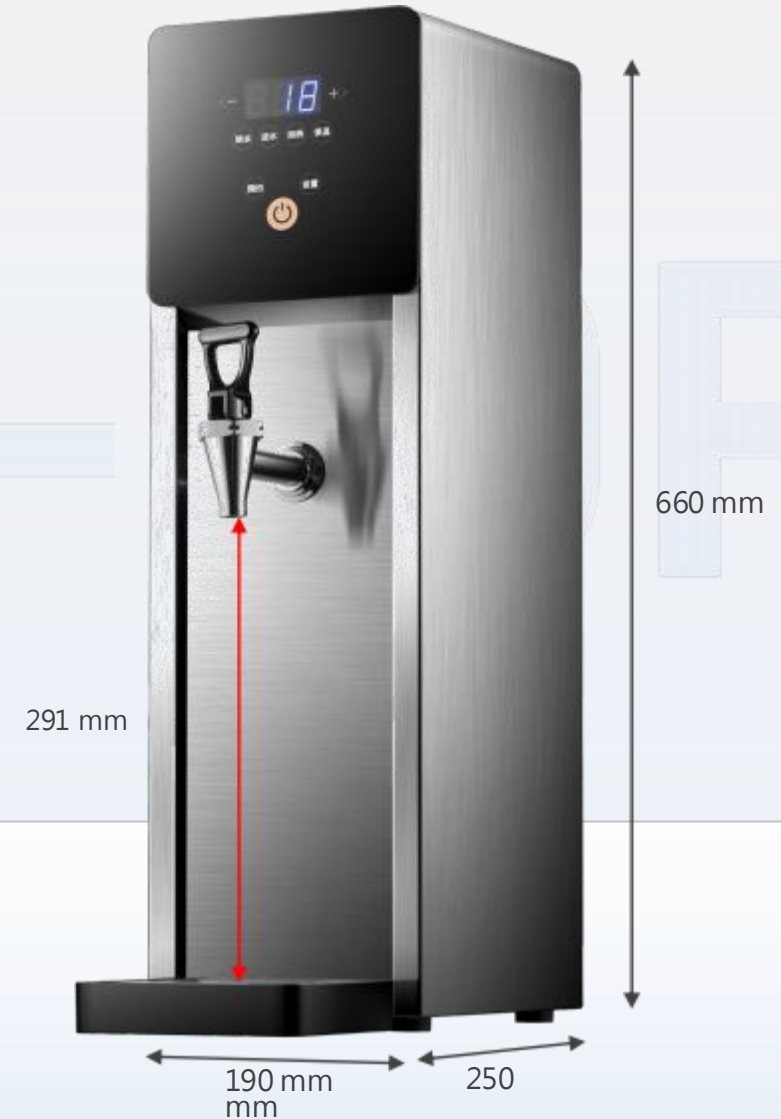

K10-20 Step Water Heater (Single Hot Bar Machine)

Product Parameter :

- 1、 Rated power: 2210W
- 2、 Rated voltage: 220V
- 3、 Rated frequency: 50Hz
- 4、 Rated capacity: 7.8L
- 5、 Water output: 20L/h
- 6、 Product dimensions: 215*240*600 mm
- 7、 Package size: 280*410*680 mm



K10-30 Step Water Heater (Single Hot Bar Machine)

Product Parameter :

- 1、 Rated power: 3000W
- 2、 Rated voltage: 220V
- 3、 Rated frequency: 50Hz
- 4、 Rated capacity: 7.8L
- 5、 Water output: 30L/h
- 6、 Product dimensions: 215*240*600 mm
- 7、 Package size: 280*410*680 mm



K 10-30S step-by-step water heater (hot and cold bar machine)

Product Parameter :

- 1、 Rated power: 3000W
- 2、 Rated voltage: 220V
- 3、 Rated frequency: 50Hz
- 4、 Rated capacity: 7.8L
- 5、 Water output: 30L/h
- 6、 Product dimensions: 235*256*600 mm
- 7、 Package size: 325*412*735mm



K7-30 Step-by-Step Water Heater (Cold and Hot Bar)

Product Parameter :

- 1、Rated power: 3000W
- 2、Rated voltage: 220V
- 3、Rated frequency: 50Hz
- 4、Rated capacity: 9.8L
- 5、Water output: 30L/h
- 6、Product dimensions: 235*235*668 mm
- 7、Package size: 325*412*735mm



F2-30A Dual-Heat Bar Machine With Step-by-Step Water Heater

Product Parameter :

- 1、 Rated power: 3000W
- 2、 Rated voltage: 220V
- 3、 Rated frequency: 50Hz
- 4、 Rated capacity: 12L
- 5、 Water output: 30L/h
- 6、 Product dimensions: 420*268*555 mm
- 7、 Package size: 485*425*630 mm



F4-20A Step-by-Step Water Heater (Single Heating, Wall-Mountable)

Product Parameter :

- 1、Rated power: 2210W
- 2、Rated voltage: 220V
- 3、Rated frequency: 50Hz
- 4、Rated capacity: 12L
- 5、Water output: 35L/h
- 6、Product dimensions: 400*215*510mm
- 7、Package size: 478*391*613mm



F4-20 Stepping Water Heater (Dual Hot/Cold Wall-Mounted)

Product Parameter :

- 1、 Rated power: 2210W
- 2、 Rated voltage: 220V
- 3、 Rated frequency: 50Hz
- 4、 Rated capacity: 12L
- 5、 Water output: 35L/h
- 6、 Product dimensions: 400*215*555 mm
- 7、 Package size: 478*391*613mm



F4-30 Step-by-Step Water Heater (Dual Hot/Cold Wall-Mounted)

Product Parameter :

- 1、 Rated power: 3000W
- 2、 Rated voltage: 220V
- 3、 Rated frequency: 50Hz
- 4、 Rated capacity: 12L
- 5、 Water output: 45L/h
- 6、 Product dimensions: 400*215*555 mm
- 7、 Package size: 478*391*613mm



F4-60 step water heater (double hot/cold wall-mounted)

Product Parameter :

- 1、 Rated power: 6000W
- 2、 Rated voltage: 380V
- 3、 Rated frequency: 50Hz
- 4、 Rated capacity: 18L
- 5、 Water production: 65 L/h
- 6、 Product dimensions: 500*215*600 mm
- 7、 Package size: 578*391*660mm



F 10-20 Step-by-Step Water Heater (Dual Hot/Cold Wall-Mounted)

Product Parameter :

- 1、Rated power: 2210W
- 2、Rated voltage: 220V
- 3、Rated frequency: 50Hz
- 4、Rated capacity: 12L
- 5、Water output: 35L/h
- 6、Product dimensions:
420*210*510mm
- 7、Package size: 478*391*613mm



F 10-30 Step-by-Step Water Heater (Dual Hot/Cold Wall-Mounted)

Product Parameter :

- 1、Rated power: 3000W
- 2、Rated voltage: 220V
- 3、Rated frequency: 50Hz
- 4、Rated capacity: 12L
- 5、Water output: 45L/h
- 6、Product dimensions: 420*210*510mm
- 7、Package size: 478*391*613mm



K9-20P Step-by-Step Water Heater

Product Parameter

- 1、 Rated power: 2210W
- 2、 Rated voltage: 220V
- 3、 Rated frequency: 50Hz
- 4、 Rated capacity: 7.8L
- 5、 Water output: 20L/h
- 6、 Product dimensions: 190*325*600 mm
- 7、 Package size: 280*410*680mm



K9-30P Step-by-Step Water Heater

Product Parameter

- 1、 Rated power: 3000W
- 2、 Rated voltage: 220V
- 3、 Rated frequency: 50Hz
- 4、 Rated capacity: 7.8L
- 5、 Water output: 30L/h
- 6、 Product dimensions: 190*325*600 mm
- 7、 Package size: 280*410*680mm



(Complimentary 2nd-Stage Filter Element)

K 11-20 Step-by-Step Water Heater

Product Parameter :

- 1、 Rated power: 2210W
- 2、 Rated voltage: 220V
- 3、 Rated frequency: 50Hz
- 4、 Rated capacity: 7.8L
- 5、 Water output: 20L/h
- 6、 Product dimensions: 260*280*600 mm
- 7、 Package size: 325*412*680mm



(Complimentary 2nd-Stage Filter Element)

K11-30 Step-by-Step Water Heater

Product Parameter :

- 1、 Rated power: 3000W
- 2、 Rated voltage: 220V
- 3、 Rated frequency: 50Hz
- 4、 Rated capacity: 7.8L
- 5、 Water output: 30L/h
- 6、 Product dimensions: 260*280*600 mm
- 7、 Package size: 325*412*680mm



(Complimentary 2nd-Stage Filter Element)

K7-30P Stepping Water Heater

Product Parameter

- 1、 Rated power: 3000W
- 2、 Rated voltage: 220V
- 3、 Rated frequency: 50Hz
- 4、 Rated capacity: 7.8L
- 5、 Water output: 30L/h
- 6、 Product dimensions: 235*235*600 mm
- 7、 Package size: 325*412*680mm

(Complimentary 2nd-Stage Filter Element)



K8-30 Step-by-Step Water Heater

Product Parameter :

- 1、 Rated power: 3000W
- 2、 Rated voltage: 220V
- 3、 Rated frequency: 50Hz
- 4、 Rated capacity: 9.8L
- 5、 Water output: 35L/h
- 6、 Product dimensions: 260*280*660 mm
- 7、 Package size: 325*412*735mm



(Complimentary 2nd-Stage Filter Element)

F8-30 Step-by-Step Water Heater

Product Parameter

- 1、 Rated power: 3000W
- 2、 Rated voltage: 220V
- 3、 Rated frequency: 50Hz
- 4、 Rated capacity: 12L
- 5、 Water output: 45L/h
- 6、 Product dimensions: 362*285*582 mm
- 7、 Package size: 485*425*630 mm



F 11-30 Step-by-Step Water Dispenser (Quantitative Water Dispensing Bar Machine)

Product Parameter :

- 1、 Rated power: 3000W
- 2、 Rated voltage: 220V
- 3、 Rated frequency: 50Hz
- 4、 Rated capacity: 12L
- 5、 Water output: 45L/h
- 6、 Product dimensions: 420*330*555 mm
- 7、 Package size: 485*425*630 mm

(Complimentary 2nd-Stage Filter Element)



F 1-BS30 Step-by-Step Water Heater

Product Parameter :

- 1、 Rated power: 3000W
- 2、 Rated voltage: 220V
- 3、 Rated frequency: 50Hz
- 4、 Rated capacity: 21L
- 5、 Water output: 60L/h
- 6、 Product dimensions: 420*260*680 mm
- 7、 Package size: 485*415*710mm

Faucet to Countertop Dimension:275 mm
(Faucet to Base Plane Dimension : 440mm)



F 1-BS60 Step-by-Step Water Heater

Product Parameter :

- 1、 Rated power: 6000W
- 2、 Rated voltage: 380V
- 3、 Rated frequency: 50Hz
- 4、 Rated capacity: 26L
- 5、 Water output: 90L/h
- 6、 Product dimensions: 420*260*760 mm
- 7、 Package size: 485*415*815mm

Faucet to Countertop Dimension:275 mm
(Faucet to Base Plane Dimension : 440mm)



F 1-BS90 Step-by-Step Water Heater

Product Parameter :

- 1、 Rated power: 9000W
- 2、 Rated voltage: 380V
- 3、 Rated frequency: 50Hz
- 4、 Rated capacity: 45L
- 5、 Water output: 160L/h
- 6、 Product dimensions: 500*280*830 mm
- 7、 Package size: 555*435*865mm

Faucet to Countertop Dimension:275 mm
(Faucet to Base Plane Dimension : 400mm)



F 1-BS12 Step-by-Step Water Heater

Product Parameter :

- 1、 Rated power: 12000W
- 2、 Rated voltage: 380V
- 3、 Rated frequency: 50Hz
- 4、 Rated capacity: 52L
- 5、 Water output: 190L/h
- 6、 Product dimensions: 500*280*910 mm
- 7、 Package size: 565*445*950mm

Faucet to Countertop Dimension:275 mm
(Faucet to Base Plane Dimension : 400mm)



F2-30 Step-by-Step Water Heater

Product Parameter :

- 1、 Rated power: 3000W
- 2、 Rated voltage: 220V
- 3、 Rated frequency: 50Hz
- 4、 Rated capacity: 21L
- 5、 Water output: 60L/h
- 6、 Product dimensions: 420*260*680 mm
- 7、 Package size: 485*415*710mm

Faucet to Countertop Dimension:318 mm
(Faucet to Base Plane Dimension : 400mm)



F2-60 Step-by-Step Water Heater

Product Parameter :

- 1、 Rated power: 6000W
- 2、 Rated voltage: 220V
- 3、 Rated frequency: 50Hz
- 4、 Rated capacity: 26L
- 5、 Water output: 90L/h
- 6、 Product dimensions: 420*260*760mm
- 7、 Package size: 485*415*815mm

Faucet to Countertop Dimension:318 mm
(Faucet to Base Plane Dimension : 400mm)



F2-90 Step-by-Step Water Heater

Product Parameter :

- 1、 Rated power: 9000W
- 2、 Rated voltage: 380V
- 3、 Rated frequency: 50Hz
- 4、 Rated capacity: 45L
- 5、 Water output: 160L/h
- 6、 Product dimensions: 500*280*830mm
- 7、 Package size: 565*435*865mm

Faucet to Countertop Dimension:318 mm
(Faucet to Base Plane Dimension : 400mm)

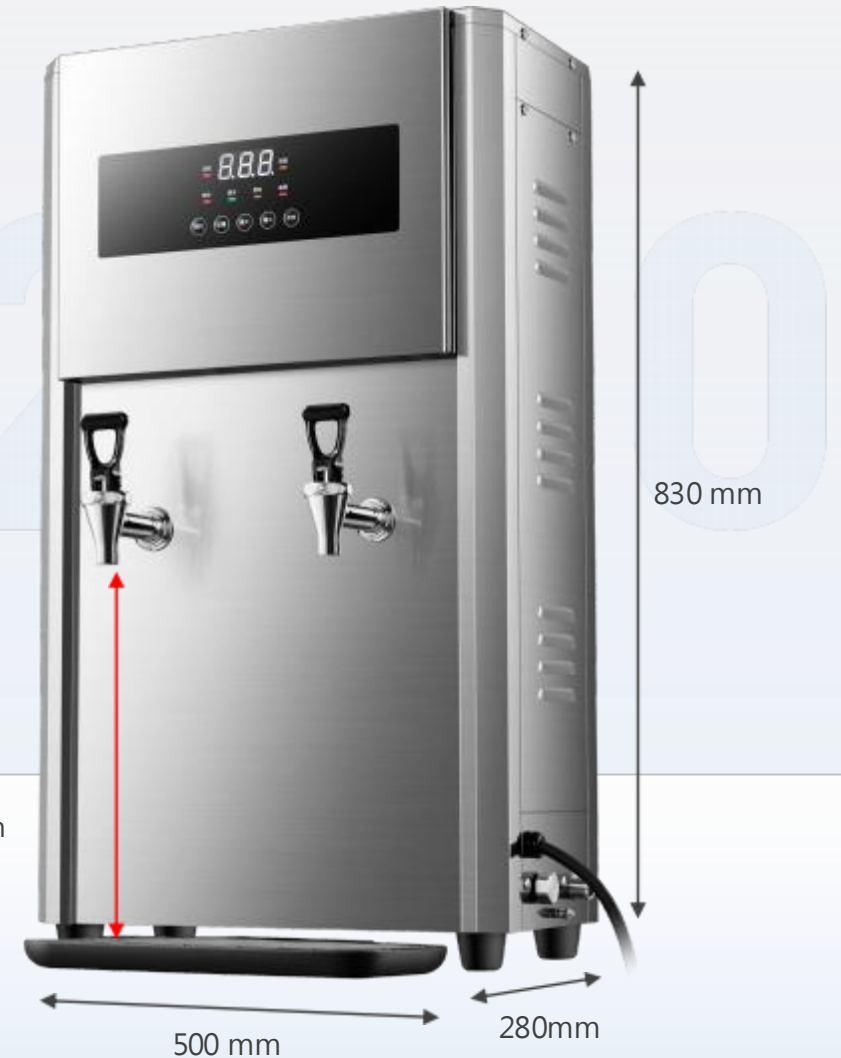

F2-12 Step-by-Step Water Heater

Product Parameter :

- 1、 Rated power: 12000W
- 2、 Rated voltage: 380V
- 3、 Rated frequency: 50Hz
- 4、 Rated capacity: 52L
- 5、 Water output: 190L/h
- 6、 Product dimensions: 500*280*910 mm
- 7、 Package size: 565*445*950mm

Faucet to Countertop Dimension:318 mm
(Faucet to Base Plane Dimension : 400mm)

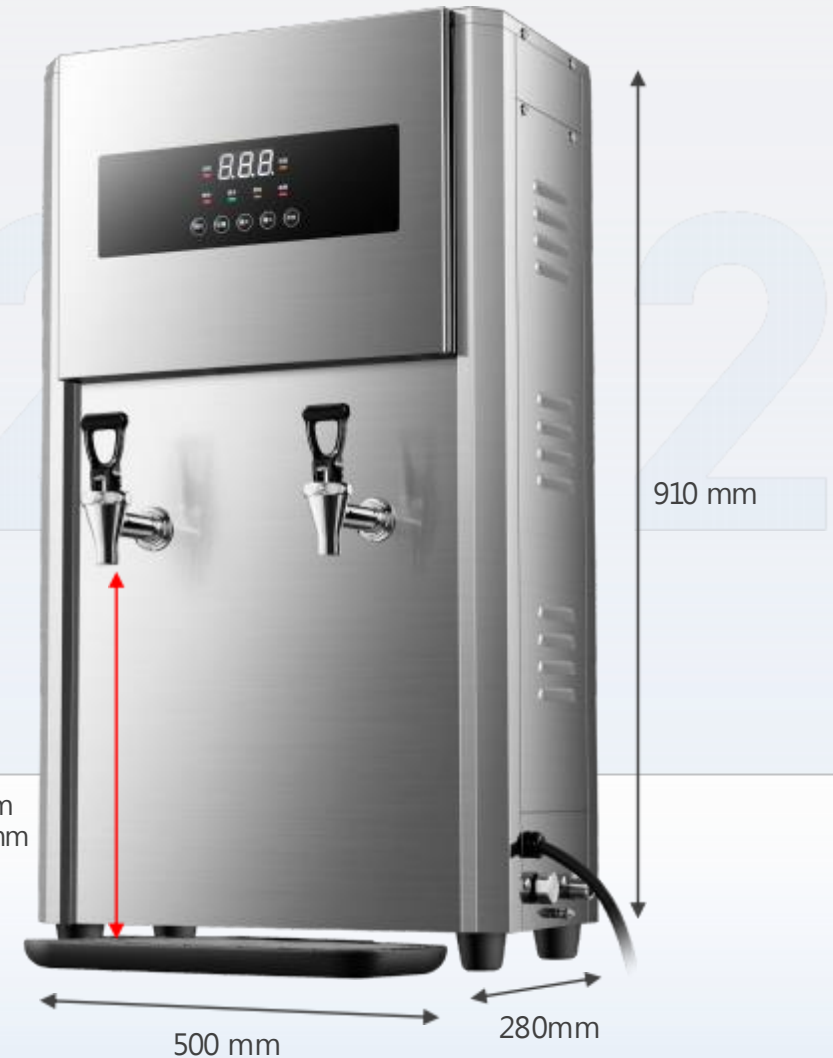

F1 Series Support Base

Product Parameter :

Product dimensions: 420×480×700mm
(for 3-6KW applications)

Product dimensions: 520*530*760mm
(for 9-12 kW)



F2 Series Support Base

Product Parameter :

Product dimensions: 420×480×620mm
(for 3-6 kW applications)

Product dimensions: 520*530*680 mm
(for 9-12 kW)



H 1-J30 Energy-Saving Direct Drinking Machine

Product Parameter :

- 1、 Power: 3000W
- 2、 Voltage/Frequency: 220V/50Hz
- 3、 Inner tank capacity: 18L
- 4、 Water output: 40L/120L per hour
- 5、 Product dimensions: 550*450*1490 mm
- 6、 Package size: 610*520*1550 mm

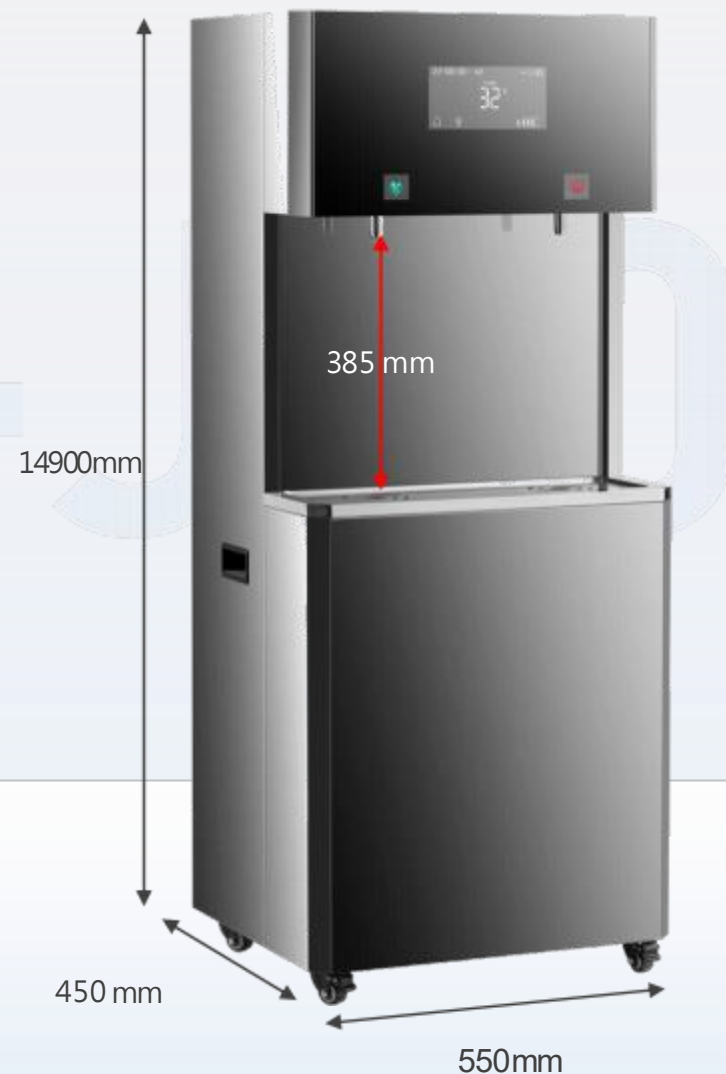

H 1-B30 Step-by-Step Direct-Drinking Machine

Product Parameter :

- 1、 Power: 3000W
- 2、 Voltage/Frequency: 220V/50Hz
- 3、 Inner tank capacity: 26L
- 4、 Water output: 60L/h
- 5、 Product dimensions: 550*460*1750 mm
- 6、 Package size: 610*520*1800 mm

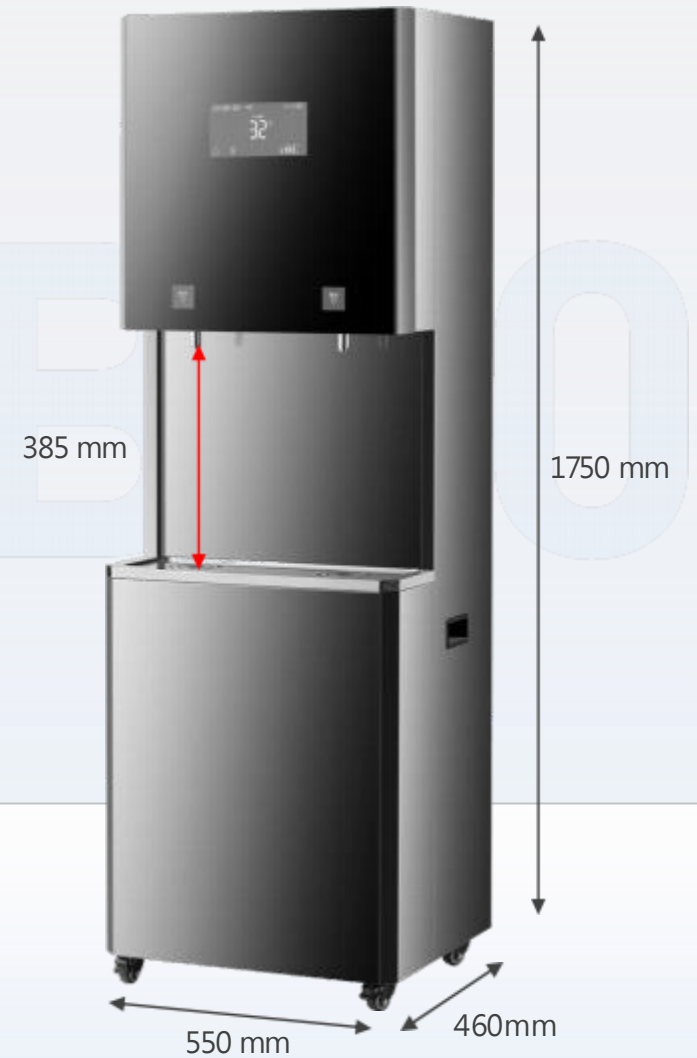

H 1-B60 Step-by-Step Direct-Drinking Machine

Product Parameter :

- 1、 Power: 6000W
- 2、 Voltage/Frequency: 380V/50Hz
- 3、 Inner tank capacity: 26L
- 4、 Water output: 90L/h
- 5、 Product dimensions: 550*460*1750 mm
- 6、 Package size: 610*520*1800 mm

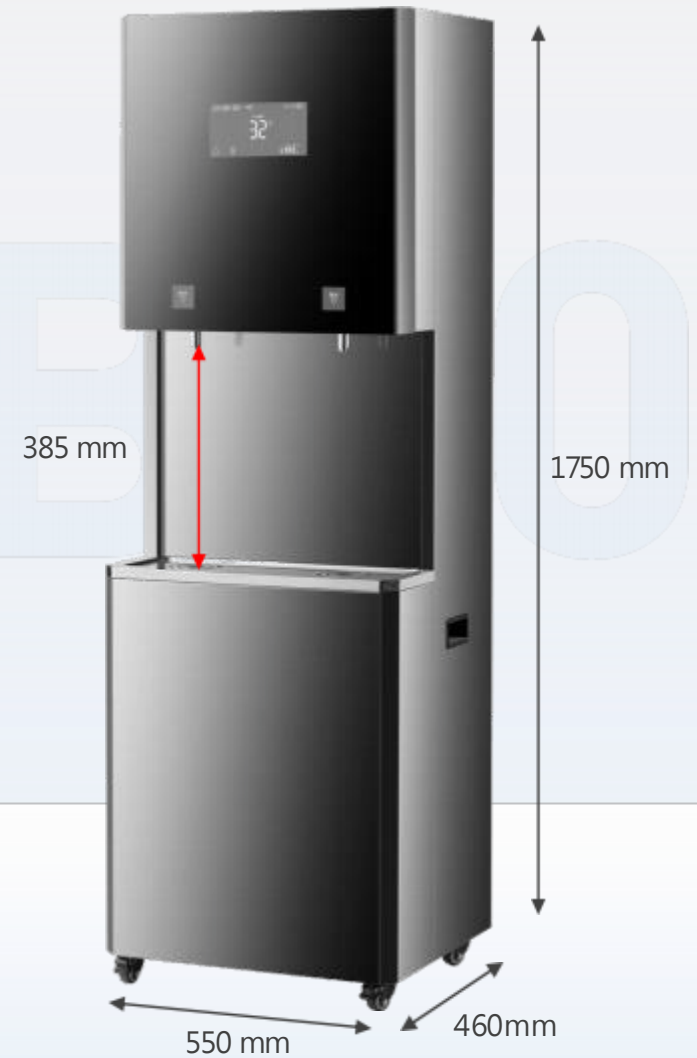

Filter Cartridge

Product Parameter :

- 1、 fast coupling
- 2、 high flux design
- 3、 Water source: municipal tap water
- 4、 Water temperature: 5°C-38°C
- 5、 Practical water pressure: ≤ 0.4 MPa



RO Membrane Filter Element

Product Parameter :

- 1、 Weight: 785g10g (including shell)
- 2、 Life span: 12-24 months
- 3、 Applicable water source: Municipal tap water meeting the requirements of GB 5749
- 4、 Water temperature: 4°C-38°C
- 5、 Practical water pressure: 0.3-0.7Mpa



Reverse Osmosis Water Purifier J1-600G

Product Parameter :

- 1、 Power: 65 W
- 2、 Voltage/Frequency: 220V/50Hz
- 3、 Rated total net water volume: 400OL
- 4、 Water flow rate: 1.5L/min
- 5、 Product dimensions: 400*165*410 mm
- 6、 Package size: 500*270*505 mm

