



MARTELLI

PREMIUM KITCHEN

搖擺湯鍋系列

TILTING KETTLE



產品性能 PRODUCT PERFORMANCE

全不銹鋼機身結構 特制爐頭, 採用火盤式加熱; 鍋體 SUS304 不銹鋼 3mm, 壺體沖壓成型 採用三夾層鍋體和獨立式蒸汽發生器, 效率高, 隔熱效果好, 蒸汽對食物進行隔水加熱, 避免食品粘底燒焦; 電動可傾式鍋體設計, 壹鍵傾鍋, 鍋體的傾斜角度超過 90 度; 蒸汽發生器帶水位控制器和自動水位調節器; 設置超壓保護、超溫保護、缺水保護功能; 按鈕式自動傾斜、復位鍋體; 雙聯電磁閥分步控制, 火種未點燃時, 主氣閥不打開

Completely SS structure with 3mm and special manufacture burner, one punched pot body with triple jacket, set up independent steaming generator, High efficiency and better insulation effect. Indirect heating food material to prevent scorched. Electric driving tilting, one button tilting and reset, tilting angle more than 90 degree. Automatically cut off the power supply and gas supply when kettle left zero position. The steaming generator had equipped with water level sensor and water level regulator, set up over temperature protection and over temperature protection. Stepwise controlled by duplex solenoid valve, the main gas valve doesn't open until the pilot ignites.



可傾式炒鍋系列

TILTING BRATT PAN



PRODUCT PERFORMANCE

The tilting series adopted indirect heating type, set up one button tilting and reset. The tilting angle more than 90 degree. Set up heating power adjust device. Automatically cut off the power supply and gas supply when kettle left zero position. Double jacket pot body with over temperature protection. SS 10mm heating plate, inner round corner treatment, can be used for frying, stewing and boiled and other functions.

產品性能 PRODUCT PERFORMANCE

可傾式炒鍋採用為為間接式加熱方式對食物進行加熱; 設備按鈕式自動傾倒、復位鍋體、可傾式超過90度; 設置可調節火力大小裝置; 當鍋體離開工作位置時, 自動切斷電源或燃氣。雙層鍋體, 設計超溫保護功能, 加熱面為10mm厚不銹鋼板, 內部圓角處理, 可用做煎、炒、燉、煮等多種功能。



产品特征
FEATURES

設備採用為間接式加熱方式對食物進行加熱
配置按鈕式自動傾倒、復位鍋體、可傾斜度超過90度
設置可調節火力大小裝置
當鍋體離開工作位置時，自動切斷電源或氣源
三層夾層鍋體和獨立式蒸汽發生器設計超壓保護、超溫保護、缺水保護功能
蒸汽發生器帶水位控制器和自動水位調節器
加熱時間35~40分鐘左右

The tilting series adopted indirect heating type, set up one button tilting and reset, tilting angle over 90 degree. Set up heating power adjustment device. Automatically cut off the power supply and gas supply when kettle left zero position. triple jacket body shell with over pressure protection, over temperature protection and water lack protection. the steaming generator had equipped with water level sensor and water level regulator. boiled time: 35 to 40 minutes

燃氣系列 Gas series

型號 Model	規格(mm) Specification	熱負荷 Gas power	電壓/功率 Voltage / power	進氣口 Gas inlet	進水口 Intake	容量 capacity
SDGT32-TSP80	1200*900*900	32kW	220V/0.2kw	DN20	DN15	80L
SDGT32-TSP100	1200*900*900	32kW	220V/0.2kw	DN20	DN15	100L
SDGT36-TSP150	1250*900*900	36kW	220V/0.2kw	DN20	DN15	150L
SDGT38-TSP200	1300*1050*900	38kW	220V/0.2kw	DN20	DN15	200L
SDGT40-TSP300	1400*1050*900	40kW	220V/0.2kw	DN20	DN15	300L

電熱系列 Electric series

型號 Model	規格(mm) Specification	電量 quantity of electricity	電源 power supply	進氣口 Gas inlet	進水口 Intake	容量 capacity
M-TSP80-E	1200*900*900	12kW	380V/50Hz	DN20	DN15	80L
M-TSP100-E	1200*900*900	12kW	380V/50Hz	DN20	DN15	100L
M-TSP150-E	1250*900*900	18kW	380V/50Hz	DN20	DN15	150L
M-TSP200-E	1300*1050*900	24kW	380V/50Hz	DN20	DN15	200L
M-TSP300-E	1400*1050*900	30kW	380V/50Hz	DN20	DN15	300L
M-TSP400-E	1550*1200*900	36kW	380V/50Hz	DN20	DN15	400L

蒸汽系列 Steam series

型號 Model	規格(mm) Specification	蒸汽量 Steam volume	電壓/功率 Voltage / power	進氣口 Gas inlet	進水口 Intake	容量 capacity
M-TSP80-Q	1200*900*900	25Kg/h	220V/0.2kw	DN20	DN15	80L
M-TSP100-Q	1200*900*900	30Kg/h	220V/0.2kw	DN20	DN15	100L
M-TSP150-Q	1250*900*900	40Kg/h	220V/0.2kw	DN20	DN15	150L
M-TSP200-Q	1300*1050*900	45Kg/h	220V/0.2kw	DN20	DN15	200L
M-TSP300-Q	1400*1050*900	65Kg/h	220V/0.2kw	DN20	DN15	300L

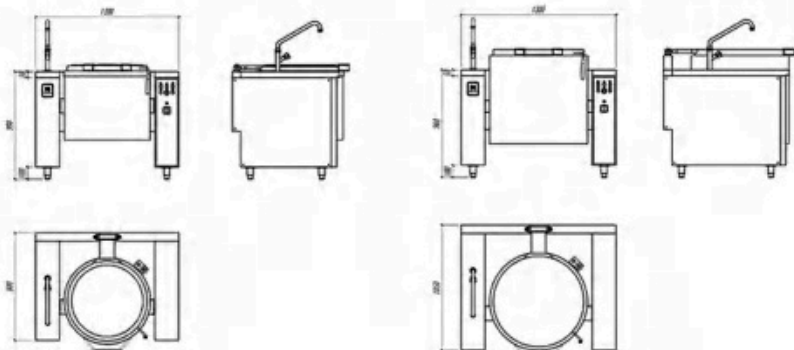

产品特征
FEATURES

設備採用為間接式加熱方式對食物進行加熱
配置按鈕式自動傾倒、復位鍋體、可傾斜度超過90度
設置可調節火力大小裝置
當鍋體離開工作位置時，自動切斷電源或燃氣
雙層鍋體，設計超溫保護功能
加熱面為12mm厚Q345高溫鋼
內部圓角處理 可用做煎、炒、燉、煮等多種功能

The tilting series adopted indirect heating type, set up one button tilting and reset, tilting angle over 90 degree. Set up heating power adjustment device. Automatically cut off the power supply and gas supply when kettle left zero position. Multi layer body shell with over pressure protection, over temperature protection and water lack protection. SS 12mm Q345 heating plate, Inner round corner treatment, can be used for frying, stewing and boiled and other functions.

燃氣系列 Gas series

型號 Model	規格(mm) Specification	熱負荷 Gas power	電壓/功率 Voltage / power	進氣口 Gas inlet	進水口 Intake	容量 capacity
SDGT14-TFP80	1200*900*900	14kW	220V/0.2kw	DN20	DN15	80L
SDGT14-TFP100	1200*900*900	14kW	220V/0.2kw	DN20	DN15	100L
SDGT21-TFP120	1600*900*900	21kW	220V/0.2kw	DN20	DN15	120L
SDGT21-TFP150	1600*900*900	21kW	220V/0.2kw	DN20	DN15	150L
SDGT21-TFP170	1600*900*900	21kW	220V/0.2kw	DN20	DN15	170L
SDGT21-TFP200	1600*900*900	21kW	220V/0.2kw	DN20	DN15	200L

電熱系列 Electric series

型號 Model	規格(mm) Specification	電量 quantity of electricity	電壓/功率 Voltage / power	進水口 Intake	容量 capacity
M-TFP80-E	1200*900*900	12kW	380V/50Hz	DN15	80L
M-TFP100-E	1200*900*900	12kW	380V/50Hz	DN15	100L
M-TFP120-E	1600*900*900	18kW	380V/50Hz	DN15	120L
M-TFP150-E	1600*900*900	18kW	380V/50Hz	DN15	150L
M-TFP170-E	1600*900*900	18kW	380V/50Hz	DN15	170L
M-TFP200-E	1600*900*900	18kW	380V/50Hz	DN15	200L

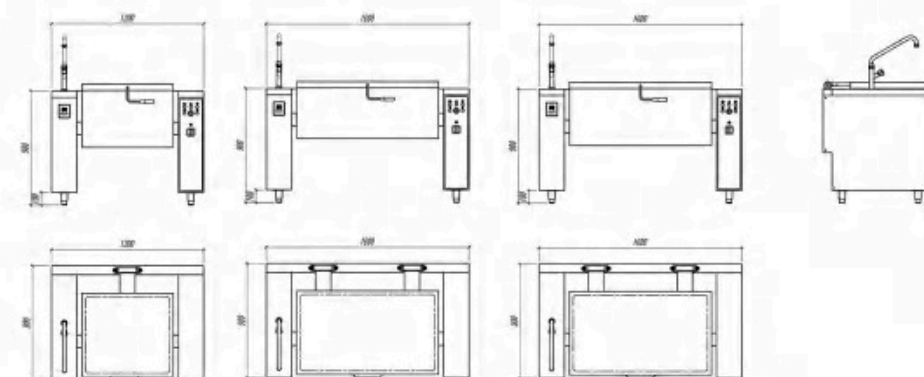

西餐爐具系列 操作安全方便

Western Cooking Range Safety And Convenient



產品性能

PRODUCT PERFORMANCE

易於安裝，操作簡單且安全。堅固的不銹鋼機身牢固地固定在可調節的不銹鋼支腳上。可調節的火焰燃燒模式可加快烹飪以及加熱過程。配備雙安全燃氣閥，壹鍵式點火按鈕，可控制引燃火焰和燃氣供應，從而使烹飪流程更加順暢。這些細節使Markphili憑藉其靈活性，高效性和有效性而成為現代專業廚房的頂級傑作。



Easy to install, simple and safe to operate. Robust stainless steel body sits firmly on adjustable stainless steel legs. Tuneable flame burning patterns speed up cooking and heating up process. Equipped with dual safety gas valves, one-touch ignition button that controls pilot flame and supply of gas, precisely smooth up the cooking workflow. These details enhance Markphili to be a premium masterpiece in modern professional kitchen by its performance in flexibility, efficiency and effectiveness.



西餐爐具特征 FEATURES

- 全不銹鋼機身結構，防水、防潮
All stainless steel body structure, waterproof, moisture proof
- 現場安裝可調不銹鋼腳，放置平穩
Adjustable SS feet convenient for install.
- 採用SU304#2.0mm厚工作臺面，整體沖壓成型容易清洗
Completely S/S body. One punched worktop with 2mm thickness
- 火力調節方便，加熱速度快
Adjustable heating power with fast heating
- 設置隔熱板和擋火板，提高熱效率，防止外部過熱
Set up heating insulation material to improve thermal efficiency and prevent external overheating.
- 設置常明火種
Set up stand pilot fire
- 配備安全制（熱電偶熄火保護裝置）
Equipped with safety system (thermocouple protection device)
- 採用與安全制聯動，自動脈沖電子點火
Double gas safety valves with automatic pulse electronic ignition.



燃氣型西餐爐具系列 | Gas western cooking range

產品特征

FEATURES

全不銹鋼機身結構；可調不銹鋼腳，放置平穩
採用 SUS 304#2.0 mm 厚工作臺面，整體沖壓成型
18mm 厚的磨砂精鋼扒板，下沈式的耐熱鋼機板無縫焊接在臺面上；火力調節方便，扒板表面溫度分佈均勻，升溫快
配置抽拉式活動的盛油盆，易於油脂收集及清潔；設置隔熱板和擋火板，提高熱效率，防止外部過熱；設置長明火種
配備安全制（熱電偶熄火保護裝置）；採用與安全制聯動，自動脈沖電子點火

Completely SS body. One punched worktop with 2mm thickness. Adjustable SS feet convenient for install. 18mm heating board made by premium stainless steel and full welding with the worktop. fast heating with thermal even distribution. equipped with drawer type grease tray and drainage hole. Set up heating insulation material to improve thermal efficiency and prevent external overheating. Set up stand pilot fire, thermocouple protection device. Double gas safety valves with automatic pulse electronic ignition.

落地式燃氣扒爐(750系列) Floor stand gas griddle(750 series)



產品名稱 Product Name	型號 Model	規格(mm) Specification	熱負荷 Gas power	燃氣口 Gas inlet
燃氣平扒爐	SRBT6-LGRF4N	400*750*850	6kW	DN20
燃氣平扒爐	SRBT6/12-LGRF8N	800*750*850	12kW	DN20
燃氣平扒爐	SRBT6/18-LGRF12N	1200*750*850	18kW	DN20
燃氣坑扒爐	SRBT6-LGRP4N	400*750*850	6kW	DN20
燃氣坑扒爐	SRBT6/12-LGRP8N	800*750*850	12kW	DN20
燃氣坑扒爐	SRBT6/18-LGRP12N	1200*750*850	18kW	DN20
燃氣1/2坑扒爐	SRBT6/12-LGRP8N1/2	800*750*850	12kW	DN20
燃氣1/2坑扒爐	SRBT6/18-LGRP12N1/2	1200*750*850	18kW	DN20
燃氣1/3坑2/3平扒爐	SRBT6/12-LGRP8N1/3	800*750*850	12kW	DN20
燃氣1/3坑2/3平扒爐	SRBT6/18-LGRP12N1/3	1200*750*850	18kW	DN20
燃氣平扒爐連下燃氣焗爐	SRB+KXT7/19-LGRF8N	800*750*850	19kW	DN20
燃氣平扒爐連下燃氣焗爐	SRB+KXT7/25-LGRF12N	1200*750*850	25kW	DN20
燃氣1/3坑2/3平扒爐連下燃氣焗爐	SRB+KXT7/19-LGRP8N1/3	800*750*850	19kW	DN20
燃氣1/3坑2/3平扒爐連下燃氣焗爐	SRB+KXT7/25-LGRP12N1/3	1200*750*850	25kW	DN20
燃氣1/2坑扒爐連下燃氣焗爐	SRB+KXT7/19-LGRP8N1/2	800*750*850	19kW	DN20
燃氣1/2坑扒爐連下燃氣焗爐	SRB+KXT7/25-LGRP12N1/2	1200*750*850	25kW	DN20

選配下焗爐帶字母O表示，選配平扒帶字母F表示，選配坑扒帶字母P表示，選配半平半坑帶字母PF表示

The oven represented by the "O". Choose smooth griddle represented by the "F". Choose groove griddle represented by the "P". Choose half smooth and half groove griddle represented by the "PF".

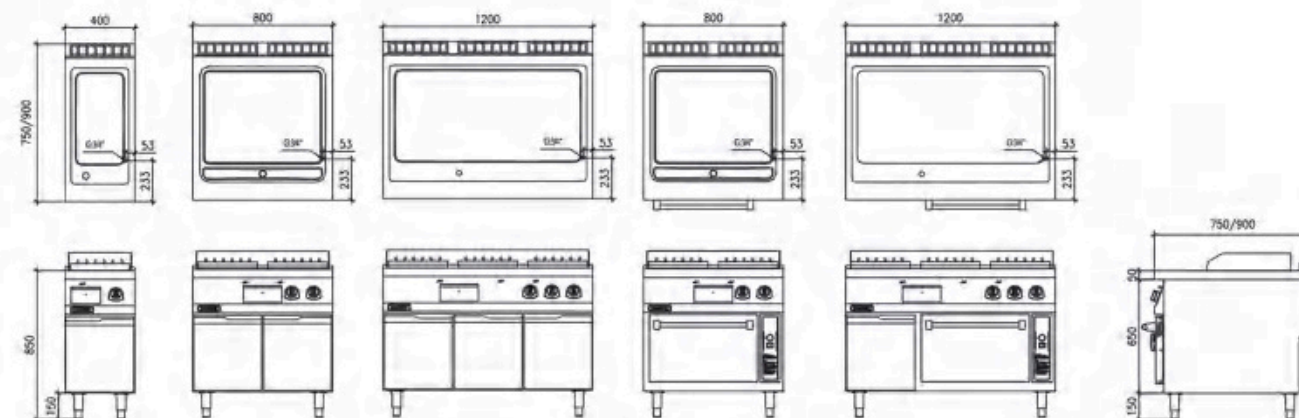

選型說明

產品名稱縮寫：坑扒LGRP 平扒LGRF 平扒坑爐LGRP

產品規格：4B表示寬400mm；8表示寬800mm；12表示寬1200mm

產品規格：H表示長900mm；N表示長750mm

加熱方式：E電熱；G燃氣

產品特征
FEATURES

全不銹鋼機身結構；可調不銹鋼腳，放置平穩
採用 SUS 304#2.0 mm 厚工作臺面，整體衝壓成型
18mm 厚的磨砂精鋼扒板，下沈式的耐熱鋼機板無縫焊接在臺面上；
火力調節方便，扒板表面溫度分佈均勻，升溫快
配置抽拉式活動的盛油盆，易於油脂收集及清潔，設置隔熱板和擋火板，提高熱效率，防止外部過熱；設置長明火種
配備安全制（熱電偶熄火保護裝置）；採用與安全制聯動，自動脈衝電子點火

Completely SS body. One punched worktop with 2mm thickness.
Adjustable SS feet convenient for install. 18mm heating board made by premium stainless steel and full welding with the worktop.
fast heating with thermal even distribution.
equipped with drawer type grease tray and drainage hole.
Set up heating insulation material to improve thermal efficiency and prevent external overheating.
Set up stand pilot fire, thermocouple protection device. Double gas safety valves with automatic pulse electronic ignition.

落地式燃氣扒爐(900系列)
floor stand gas griddle(900 series)



產品名稱 Product Name	型號 Model	規格(mm) Specification	熱負荷 Gas power	進氣口 Gas inlet
燃氣平扒爐	SRBT7-LGRF4H	400*900*850	7kW	DN20
燃氣平扒爐	SRBT7/14-LGRF8H	800*900*850	14kW	DN20
燃氣平扒爐	SRBT7/21-LGRF12H	1200*900*850	21kW	DN20
燃氣坑扒爐	SRBT7-LGRP4H	400*900*850	7kW	DN20
燃氣坑扒爐	SRBT7/14-LGRP8H	800*900*850	14kW	DN20
燃氣坑扒爐	SRBT7/21-LGRP12H	1200*900*850	21kW	DN20
燃氣1/2坑扒爐	SRBT7/14-LGRP8H1/2	800*900*850	14kW	DN20
燃氣1/2坑扒爐	SRBT7/21-LGRP12H1/2	1200*900*850	21kW	DN20
燃氣1/3坑2/3平扒爐	SRBT7/14-LGRP8H1/3	800*900*850	14kW	DN20
燃氣1/3坑2/3平扒爐	SRBT7/21-LGRP12H1/3	1200*900*850	21kW	DN20
燃氣平扒爐連下燃氣焗爐	SRB+KXT7/21-LGRF8H	800*900*850	21kW	DN20
燃氣平扒爐連下燃氣焗爐	SRB+KXT7/28-LGRF12H	1200*900*850	28kW	DN20
燃氣1/2坑扒爐連下燃氣焗爐	SRB+KXT7/21-LGRP8H1/2	800*900*850	21kW	DN20
燃氣1/2坑扒爐連下燃氣焗爐	SRB+KXT7/28-LGRF12H1/2	1200*900*850	28kW	DN20
燃氣1/3坑2/3平扒爐連下燃氣焗爐	SRB+KXT7/21-LGRP8H1/3	800*900*850	21kW	DN20
燃氣1/3坑2/3平扒爐連下燃氣焗爐	SRB+KXT7/28-LGRF12H1/3	1200*900*850	28kW	DN20

選配下焗爐帶字母O表示,選配平扒帶字母F表示,選配坑扒帶字母P表示,選配半平扒帶字母PF表示

The oven represented by the "O".Choose smooth griddle represented by the "F".Choose groove griddle represented by the "P".Choose half smooth and half groove griddle represented by the "PF".

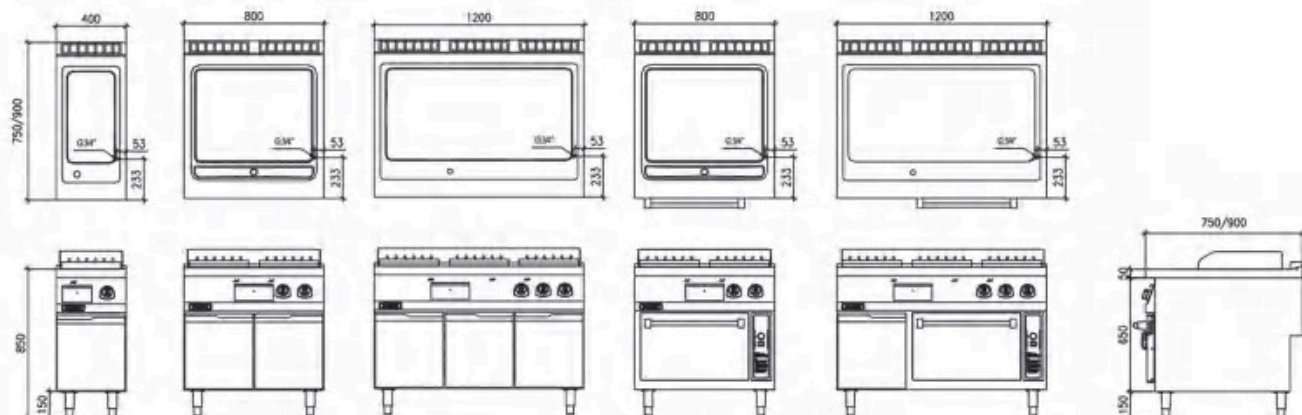

選型說明

產品名稱縮寫：坑扒LGRP 平扒LGRF 平扒坑爐LGRP

產品規格：4B表示寬400mm；8表示寬800mm；12表示寬1200mm

產品規格：H表示長900mm；N表示長750mm

加熱方式：E電熱；G燃氣

產品特征
FEATURES

全不銹鋼機身結構；可調不銹鋼腳，放置平穩
採用 SUS 304#2.0 mm 厚工作臺面，整體衝壓成型
特別爐花設計，爐頭為止之間平面可放置平底鍋
配置抽拉式活動的盛油盆，易於油脂收集及清潔
單雙環爐頭交叉配置，多種不同大小火力可選擇
爐頭防止堵塞；設置長明火種
配備安全制（熱電偶熄火保護裝置）
採用與安全制聯動，自動脈衝電子點火

Completely SS body. One punched worktop with 2mm thickness.
Adjustable SS feet convenient for install
Special designed grid ,equipped with drawer type grease tray and drainage hole ,easily collection and clean .
Single ring burner and double ring burner cross layout,kinds of heating power for options.
Set up stand pilot fire,thermocouple protection device ,Double gas safety valves with automatic pulse electronic ignition.

落地式燃氣平頭爐
Floor stand gas range



產品名稱 Product Name	型號 Model	規格(mm) Specification	熱負荷 Gas power	進氣口 Gas inlet
燃氣雙頭平頭爐	SPTT8/13-LPF4N	400*750*850	13kW	DN20
燃氣四頭平頭爐	SPTT8/26-LPF8N	800*750*850	26kW	DN20
燃氣六頭平頭爐	SPTT8/39-LPF12N	1200*750*850	39kW	DN20
燃氣雙頭平頭爐	SPTT8/13-LPF4H	400*900*850	13kW	DN20
燃氣四頭平頭爐	SPTT8/26-LPF8H	800*900*850	26kW	DN20
燃氣六頭平頭爐	SPTT8/39-LPF12H	1200*900*850	39kW	DN20
燃氣四頭平頭爐下電熱焗爐	SPTT8/26-LPF8NOE	800*750*850	26kW	DN20
燃氣六頭平頭爐下電熱焗爐	SPTT8/39-LPF12NOE	1200*750*850	39kW	DN20
燃氣四頭平頭爐下電熱焗爐	SPTT8/26-LPF8HOE	800*900*850	26kW	DN20
燃氣六頭平頭爐下電熱焗爐	SPTT8/39-LPF12HOE	1200*900*850	39kW	DN20
燃氣四頭平頭爐下燃氣焗爐	SKX+PTT8/33-LPF8N	800*750*850	33kW	DN20
燃氣六頭平頭爐下燃氣焗爐	SKX+PTT8/46-LPF12N	1200*750*850	46kW	DN20
燃氣四頭平頭爐下燃氣焗爐	SKX+PTT8/33-LPF8H	800*900*850	33kW	DN20
燃氣六頭平頭爐下燃氣焗爐	SKX+PTT8/46-LPF12H	1200*900*850	46kW	DN20

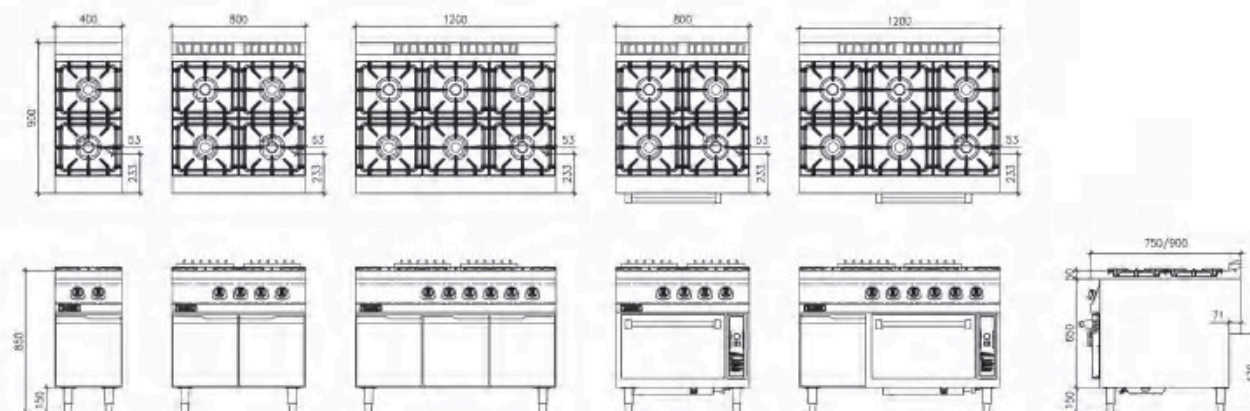

產品特征
FEATURES

全不銹鋼機身結構；可調不銹鋼腳，放置平穩
採用 SUS 304#2.0 mm 厚工作臺面，整體衝壓成型
耐火不銹鋼反熱板加熱，加熱速度快，火力調節反應快配置抽
拉式活動的盛油盆，易於油脂收集及清潔
三面防濺擋板可通過不銹鋼的掛扣完整的拆卸
設置長明火種；配備安全制（熱電偶熄火保護裝置）
採用與安全制聯動，自動脈衝電子點火
獨特的可調角度耐火鑄鐵搪瓷燒烤架，防止燒烤殘油污染食物

Completely SS body. One punched worktop with 2mm thickness.
Adjustable SS feet convenient for install.
Fast heating with thermal even distribution.
Equipped with drawer type grease tray and drainage hole.
Set up heating insulation material and reflecting board to improve thermal efficiency.
Set up removable splash guards around the grid
Set up stand pilot fire, thermocouple protection device. Double gas safety valves with automatic pulse electronic ignition.
Adopted adjustable angle cast iron grid to prevent the grease polluting the food.

落地式燃氣燒烤爐
Floor Stand Gas Grill



名稱 name	型號 Model	規格(mm) Specification	熱負荷 Gas power	進氣口 Gas inlet
燃氣燒烤爐下儲物櫃	SSKT7-LBS4N	400*750*850	7kW	DN20
燃氣燒烤爐下儲物櫃	SSKT7/14-LBS8N	800*750*850	14kW	DN20
燃氣燒烤爐下儲物櫃	SSKT7/21-LBS12N	1200*750*850	21kW	DN20
燃氣燒烤爐下儲物櫃	SSKT9-LBS4H	400*900*850	9kW	DN20
燃氣燒烤爐下儲物櫃	SSKT9/18-LBS8H	800*900*850	18kW	DN20
燃氣燒烤爐下儲物櫃	SSKT9/27-LBS12H	1200*900*850	27kW	DN20

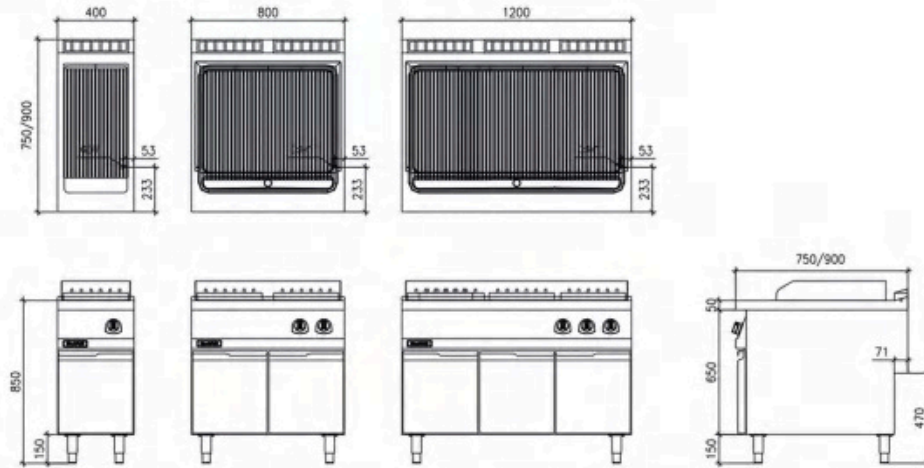

產品特征
FEATURES

全不銹鋼機身結構；可調不銹鋼腳，放置平穩
火管式加熱傳熱效率高，可防止粘底及爐體溫度過高
新型深沖壓式炸缸（18L），炸缸底部有V形冷涼區沈積渣物
放油閥設置自鎖裝置，防止誤操作
帶有235°C超溫安全設置，可手動復位
EGO溫控器，溫度調節60°C~190°C，設置常明火種
脈衝電子點火；離子熄火保護
安裝需要預留220V/50Hz/0.2kW用電

Completely SS body. Adjustable SS feet convenient for install.
Innovation fire tube burner with high heating efficiency to prevent fryer body over heating.
Deep punched tank (18L) with V-type cold area for store residues.
Oil drainage had equipped with self lock device to prevent the misoperation.
EGO temperature controller and temperature range 60°C~190°C. Equipped with over temperature protection(230°C)with manual reset.
Set up stand pilot fire, thermocouple protection device. Double gas safety valves with automatic pulse electronic ignition

落地式燃氣炸爐
Floor Stand Gas Deep Fryer



名稱 name	型號 Model	規格(mm) Specification	熱負荷 Gas power	進氣口 Gas inlet	備註 Remarks
燃氣單缸炸爐下儲物櫃	SZLT10-LBF4N	400*750*850	10kW	DN20	配1个炸筛
燃氣雙缸炸爐下儲物櫃	SZLT10/20-LBF8N	800*750*850	20kW	DN20	配2个炸筛
燃氣單缸炸爐下儲物櫃	SZLT10-LBF4H	400*900*850	10kW	DN20	配1个炸筛
燃氣雙缸炸爐下儲物櫃	SZLT10/20-LBF8H	800*900*850	20kW	DN20	配2个炸筛
燃氣工業炸爐下儲物櫃	M-LBFL8N-G	800*750*850	28kW	DN20	配2个炸筛
燃氣工業炸爐下儲物櫃	M-LBFL8H-G	800*900*850	28kW	DN20	配2个炸筛

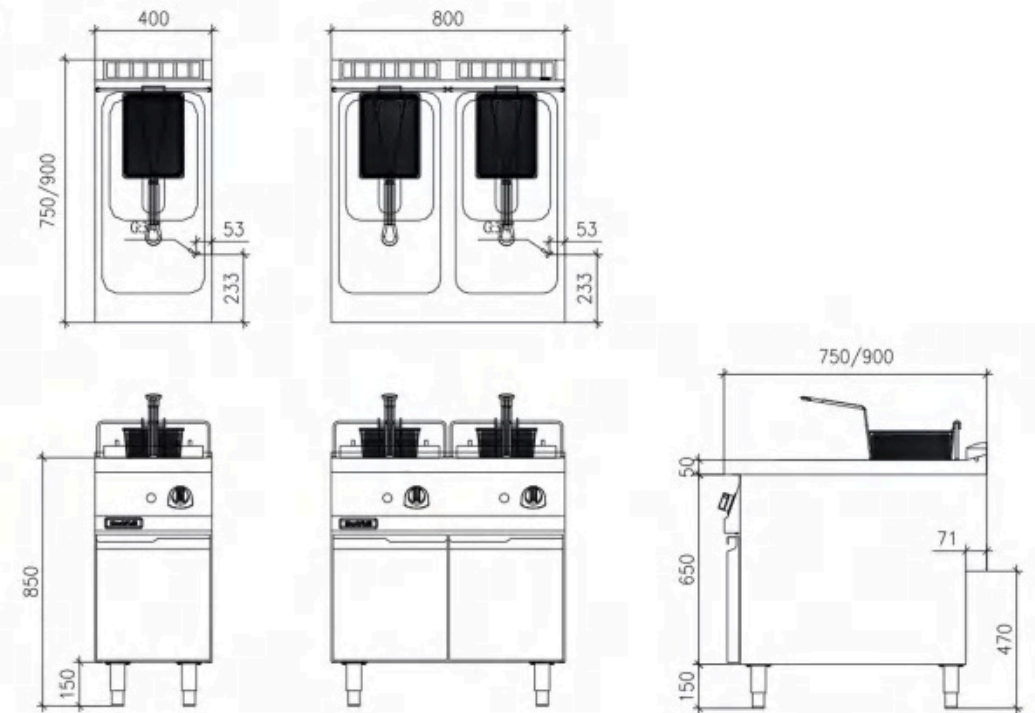

產品特征
FEATURES

全不銹鋼機身結構；可調不銹鋼腳，放置平穩
採用 SUS 304#2.0 mm 厚工作臺面，整體衝壓成型
自動補水，容易清除面渣
火管式加熱，傳熱效率高，可防止粘底及爐體溫度過高
沸騰水泡自動爆散麵團，並防止沸水濺溢
設置溢水槽；煮面缸容置大，升溫速度快
設置長明火種；配備安全制（熱電偶熄火保護裝置）
採用與安全制聯動，自動脈衝電子點火

Completely SS body, One punched worktop with 2mm thickness.
Adjustable SS feet convenient for install.
Innovation fire tube burner with high heating efficiency to prevent body over heating.
Automatic refilling water, easily clean noodle residue.
Automatic devided noodle dough by the boiled water bubble.
equipped with overflowing device and big capacity basket.
Set up stand pilot fire, thermocouple protection device,
Double gas safety valves with automatic pulse electronic ignition.

落地式燃氣意粉爐
Floor Stand Gas Pasta Cooker



名稱 name	型號 Model	規格(mm) Specification	熱負荷 Gas power	進氣口 Gas inlet	備註 Remarks
燃氣單缸意粉爐	SZST6/12-LSF4N	400*750*850	12kW	DN20	配3个意粉篩
燃氣雙缸意粉爐	SZST6/24-LSF8N	800*750*850	24kW	DN20	配6个意粉篩
燃氣單缸意粉爐	SZST6/12-LSF4H	400*900*850	DN20	配4个意粉篩	
燃氣雙缸意粉爐	SZST6/24-LSF8H	800*900*850	24kW	DN20	配8个意粉篩

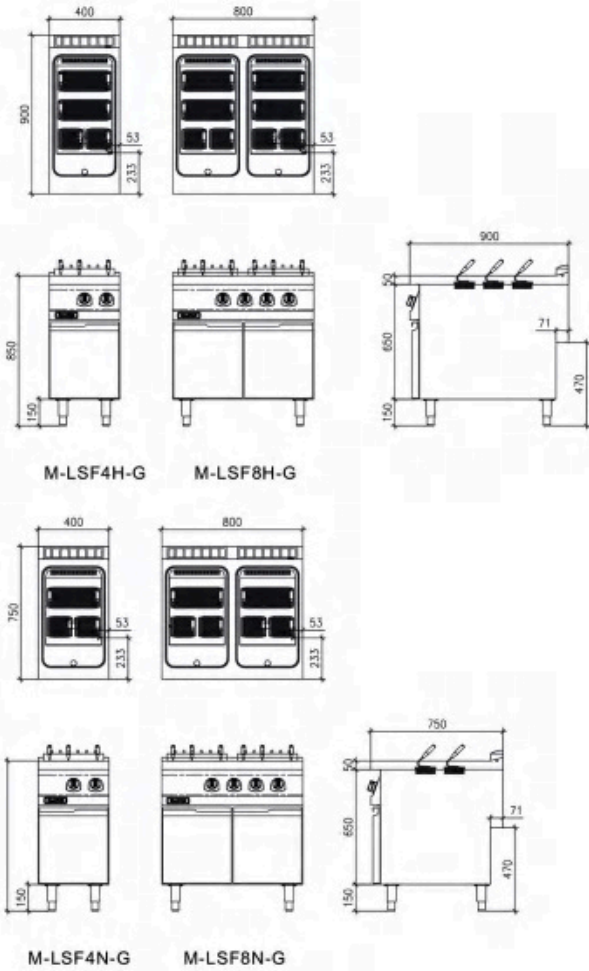

產品特征
FEATURES

全不銹鋼機身結構；可調不銹鋼腳，放置平穩
採用 SUS 304#2.0 mm 厚工作臺面，整體衝壓成型
自動補水，容易清除面渣
火管式加熱，傳熱效率高，可防止粘底及爐體溫度過高
沸騰水泡自動爆散麵團，並防止沸水濺溢
設置溢水槽；煮面缸容置大，升溫速度快
設置長明火種；配備安全制（熱電偶熄火保護裝置）
採用與安全制聯動，自動脈衝電子點火

Completely SS body, One punched worktop with 2mm thickness.
Adjustable SS feet convenient for install.
Innovation fire tube burner with high heating efficiency to prevent body over heating.
Automatic refilling water, easily clean noodle residue.
Automatic devided noodle dough by the boiled water bubble.
equipped with overflowing device and big capacity basket.
Set up stand pilot fire, thermocouple protection device,
Double gas safety valves with automatic pulse electronic ignition.

落地式燃氣煮面爐
Floor Stand Gas Noodle Boiler



名稱 name	型號 Model	規格(mm) Specification	熱負荷 Gas power	進氣口 Gas inlet
燃氣單缸煮面爐	SZST6/12-LPC4N	400*750*850	12kW	DN20
燃氣單缸煮面爐連冷水盤	SZST6/12-LPC8N	800*750*850	12kW	DN20
燃氣雙缸煮面爐	SZST6/24-LPC8N2	800*750*850	24kW	DN20
燃氣單缸煮面爐	SZST6/12-LPC4H	400*900*850	12kW	DN20
燃氣單缸煮面爐連冷水盤	SZST6/12-LPC8H	800*900*850	12kW	DN20
燃氣雙缸煮面爐	SZST6/24-LPC8H2	800*900*850	24kW	DN20

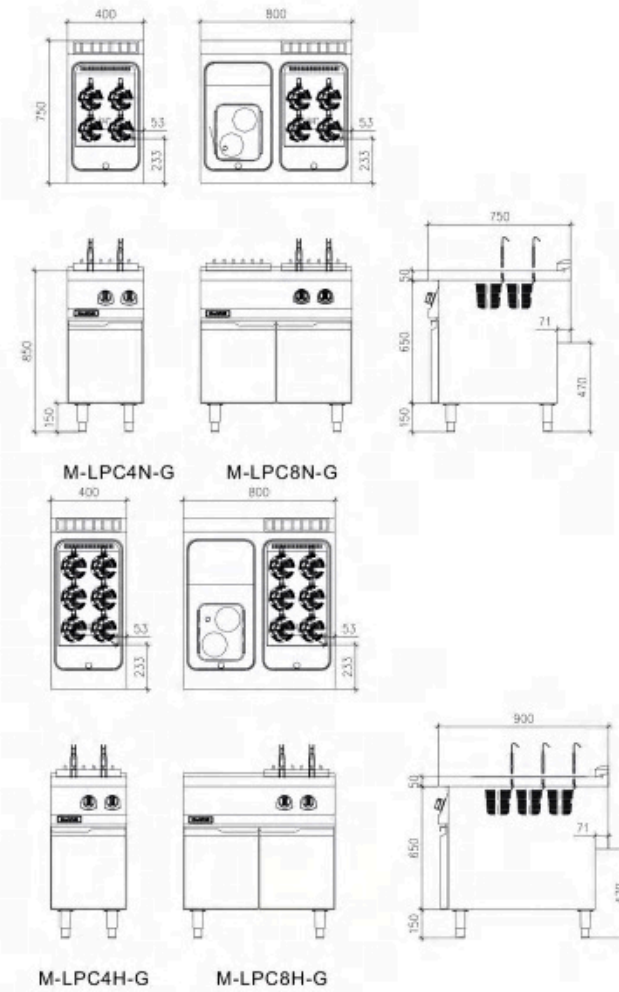

產品特征
FEATURES

全不銹鋼機身結構；可調不銹鋼腳，放置平穩
設置隔熱板和擋火板，提高熱效率，防止外部過熱
設置長明火種；配置安全制（熱電偶熄火保護裝置）
採用與安全制聯動，自動脈衝電子點火
熱板的中央部分集中導熱；熱板表面溫度分布均勻，升溫快
爐火開關控制雙圈爐頭，可根據需要分別開外圈火和內圈火

Completely SS body, Adjustable SS feet convenient for install.
Set up heating insulation material to improve thermal efficiency and prevent external overheating.
Set up stand pilot fire, thermocouple protection device.
Double gas safety valves with automatic pulse electronic ignition.
Plate center heat transmission with thermal even distribution.
Double ring burner: the outer ring flame and inner ring flame can be independent control according to needs.

產品特征
FEATURES

全不銹鋼機身結構；可調不銹鋼腳，放置平穩
採用 SUS 304#1.5 mm 厚工作臺面，整體衝壓成型
向內火環保預混爐頭
採用燃燒控制器分布控制雙聯電磁閥，火種未點燃時，主氣
閥不打開；配置有搖擺水龍頭
穩壓調壓器，燃燒火焰穩定
脈衝電子點火；常明火種設置，離子檢測熄火保護
每個爐頭配置獨立風機（220V/50Hz/100W）

Completely SS body, Adjustable SS feet convenient for install.
One punched worktop with 1.5 mm thickness.
Stepwise controlled by duplex solenoid valve, the main gas valve doesn't open until the fire ignites.
Equipped with swimming faucet, gas pressure regulator with stabilized combustion.
Set up stand pilot fire, thermocouple protection device.
Double gas safety valves with automatic pulse electronic ignition.
Every burner equipped with one blower (220V/50Hz/100W)

落地式燃氣熱板爐
Floor Stand Gas Solid Top



名稱 name	型號 Model	規格(mm) Specification	熱負荷 Gas power	進氣口 Gas inlet
燃氣熱板爐	SRBT9-LHR8N	800*750*850	9kW	DN20
燃氣熱板爐	SRBT9-LHR8H	800*900*850	9kW	DN20
燃氣單頭熱板爐下焗爐	SKX+RBT9/16-LHR8N	800*750*850	16kW	DN20
燃氣單頭熱板爐下焗爐	SKX+RBT9/16-LHR8H	800*900*850	16kW	DN20

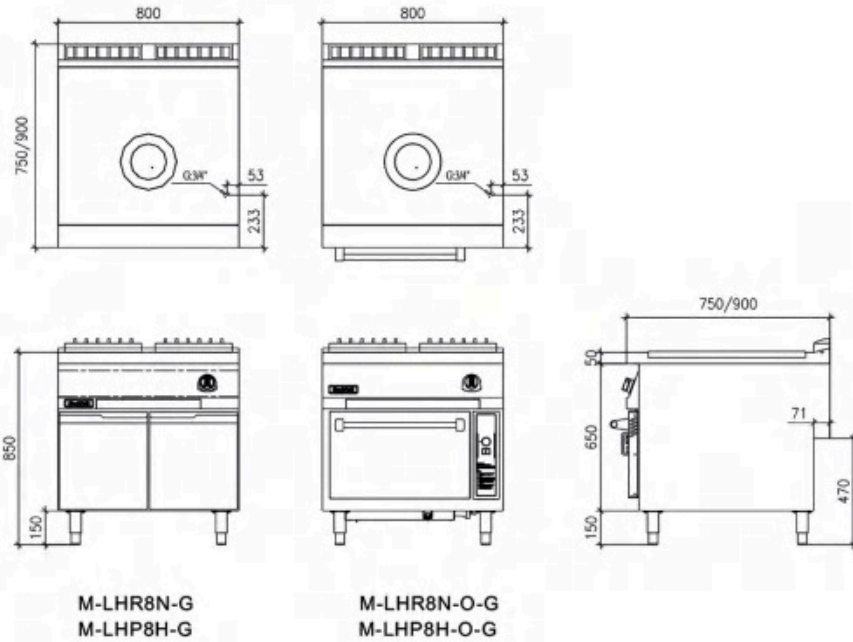

選配下焗爐帶字母O表示
The oven represented by the "O"

落地式燃氣炒爐
Floor Stand Gas Cooking Wok



名稱 name	型號 Model	規格(mm) Specification	熱負荷 Gas power	电压/功率 Voltage / power	進氣口 Gas inlet
西式燃氣炒爐	SZCT32-LCZ8N	800*750*850	32kW	220V, 0.10kW	DN20
西式燃氣單頭單尾炒爐	SZCT32-LCZ12N	1200*750*850	32kW	220V, 0.10kW	DN20
西式燃氣雙頭單尾炒爐	SZCT32/64-LCZ18N	1800*750*850	64kW	220V, 0.10kW	DN20
西式燃氣炒爐	SZCT32-LCZ8H	800*900*850	32kW	220V, 0.10kW	DN20
西式燃氣單頭單尾炒爐	SZCT32-LCZ12H	1200*900*850	32kW	220V, 0.20kW	DN20
西式燃氣雙頭單尾炒爐	SZCT32/64-LCZ18H	1800*900*850	64kW	220V, 0.20kW	DN20

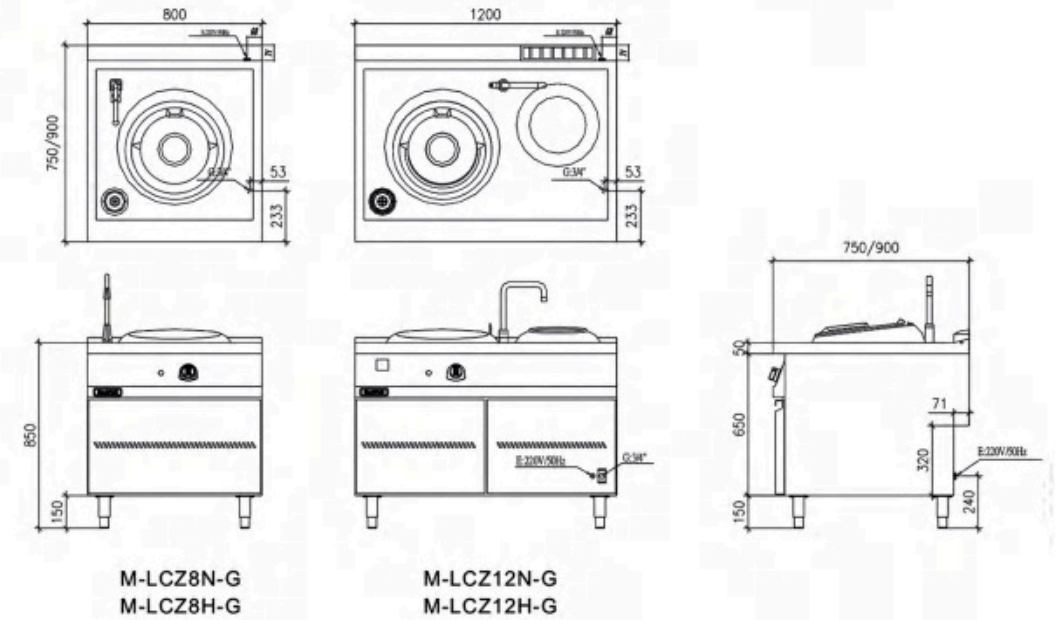

燃氣型西餐爐具系列 | Gas Western Cooking Range

產品特征
FEATURES

全不銹鋼機身結構；可調不銹鋼腳，放置平穩
 采用SUS304#1.5mm厚工作臺面，整體沖壓成型
 2只自引射環保爐頭；設置常明火種，配置電磁安全制，意外熄火等
 故障，壹秒鐘關閉燃氣；脈沖電子打火和離子熄火保護設計；燃燒
 無需風機鼓風，節約用電
 壓力平衡式自動補水箱，保證水膽水位平衡
 設置超溫缺水保護，防止幹燒
 配不銹鋼擡出水龍頭；安裝需要預留220V/50Hz/0.025kW用電；硬
 水地區使用該設備必須裝配軟化水設置

Completely SS body, Adjustable SS feet convenient for install.
 One punched worktop with 1.5 mm thickness.
 Double gas safety valves with automatic pulse electronic ignition.
 Inject burner with out blower. Set up stand pilot fire with safety gas
 valve, the gas supply will be cut off in 1 second when gas or air
 supply abnormally.
 The main gas valve doesn't open until the fire ignites.
 Floating ball type water box, automatic water inject to keep the water
 level balance, set up over temperature and dry heating protection.
 Set up stand pilot fire, thermocouple protection device.
 Equipped with mounted faucet. Every burner equipped with one
 blower (220V/50HZ/100w)
 Required to install water softener for hard water areas

落地式燃氣蒸爐 FLOOR STAND GAS STEAMER FURNACE



型號 Model	SCZT26-LCSE8	SCZT26-LCSE8
規格(mm) Specification	800*750*850	800*900*850
熱負荷 Gas power	26kW	26kW
耗電量 Power consumption	220V/0.025kW	220V/0.025kW
進氣口 Gas inlet	DN20	DN20
進水口/排水口 Water inlet / outlet	DN15/DN40	DN15/DN40
備註 Remarks	配蒸板	配蒸板

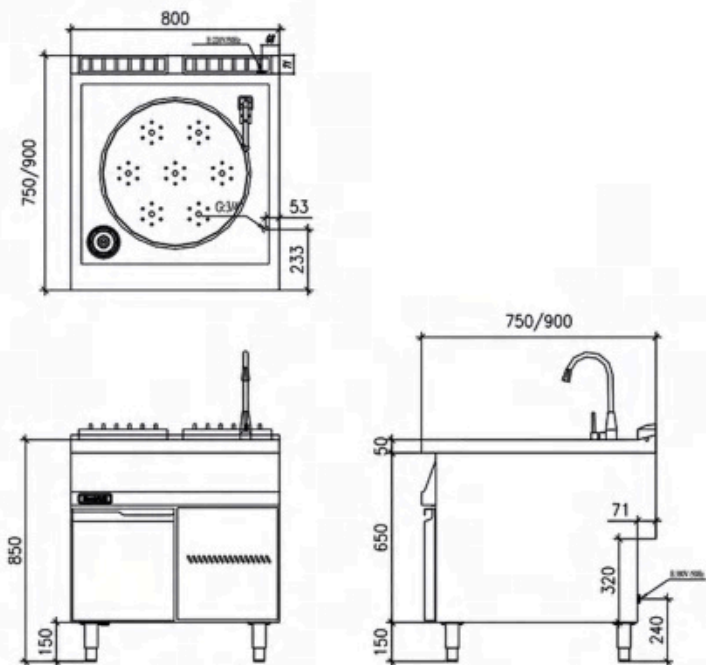

燃氣型西餐爐具系列 | Gas Western Cooking Range

產品特征
FEATURES

全不銹鋼機身結構；可調不銹鋼腳，放置平穩雙層鍋體，鏡面
 拋光特制爐頭；深沖壓式雙層鍋蓋，蒸汽對食物進行隔水加熱
 ，避免食物年底燒焦，設置超壓保護，超溫保護，缺水保護，達
 到排氣壓力時，安全閥自動排氣，設置常明火種配置安全制(離
 子熄火監測保護裝置)；採用與安全制聯動，自動脈沖電子點
 火，使用方便；自動或手動補充夾層軟水設備配置安全泄壓閥，
 夾層壓力大於0.3Mpa時開放，保證使用安全，設置真空減壓閥
 ，調節腔內壓力，保證加熱過程中空氣的釋放

Completely SS body, Adjustable SS feet convenient for install.
 Deeply Punched SUS #304 double jacket lid and body, indirect
 heating to avoid burnt food.
 Double gas safety valves with automatic pulse electronic ignition, set
 up stand pilot, automatic filling water or manual filling in tank for
 options.
 Equipped with specially burner and over pressure protection, over
 temperature protection, water level protection.
 Relief valve automatic release steaming to adjust the chamber
 pressure and also make sure safety when pressure arrived 0.3Mpa

落地式西式燃氣湯鍋 FLOOR STANDING WESTERN STYLE GAS



型號 Model	M-WSP80-G	M-WSP100-G
規格(mm) Specification	800x900x850	800x900x850
熱負荷 Gas power	20kW	20kW
耗電量 Power consumption	220V/0.025kW	220V/0.025kW
進氣口 Gas inlet	DN20	DN20
進水口/排水口 Water inlet / outlet	DN15/DN40	DN15/DN40
備註 Remarks		

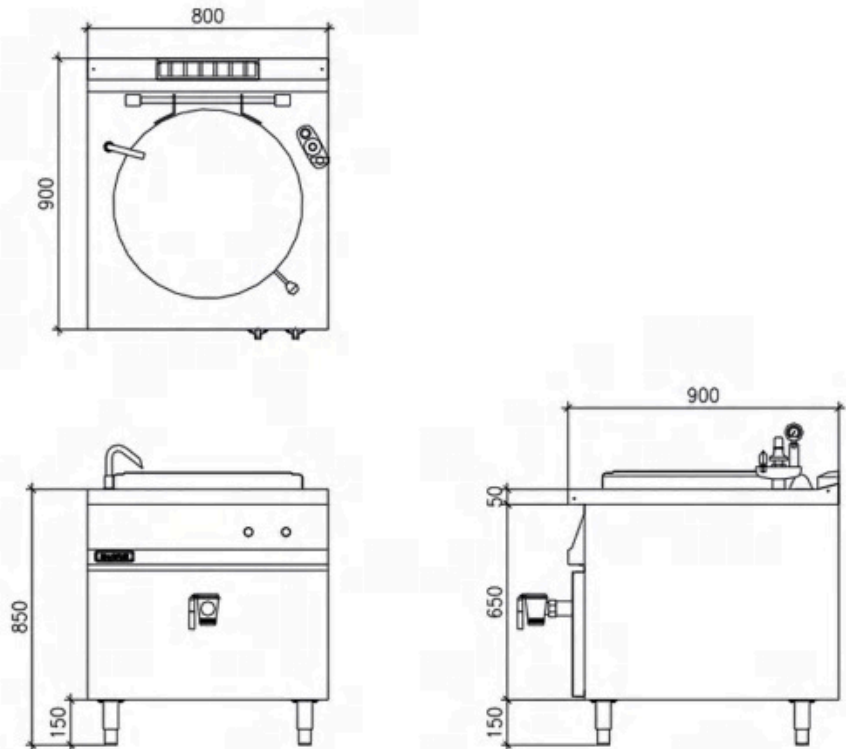

產品特征
FEATURES

全不銹鋼機身結構；可調不銹鋼腳，放置平穩
不銹鋼雙層鍋蓋圓角，無縫焊接鍋體
電動傾斜，可超過90度
鍋底採用12mm厚的低碳鋼或復合鋼制成
可調節溫度大小；設置常明火種
配備安全制（離子熄火檢測保護裝置）
採用與安全制聯動，自動脈沖電子點火，使用方便

Completely SS body, Adjustable SS feet convenient for install.
One punched worktop with 1.5 mm thickness.
Double gas safety valves with automatic pulse electronic ignition,
Set up stand pilot fire, thermocouple protection device.
Double jacket lid, fulling welding pot body, tilting angle more over 90 degree. 12mm low-carbon steel or composite steel of the pot body material

落地式燃氣炒鍋 FLOOR STAND GAS BRATT PAN



型號 Model	M-WFP8H-G	M-WFP12H-G
規格(mm) Specification	800*900*850	1200*900*850
熱負荷 Gas power	14kW	21kW
耗電量 Power consumption	220V/0.1kW	220V/0.1kW
進氣口 Gas inlet	DN20	DN20
進水口/排水口 Water inlet / outlet	DN15	DN15
備註 Remarks		

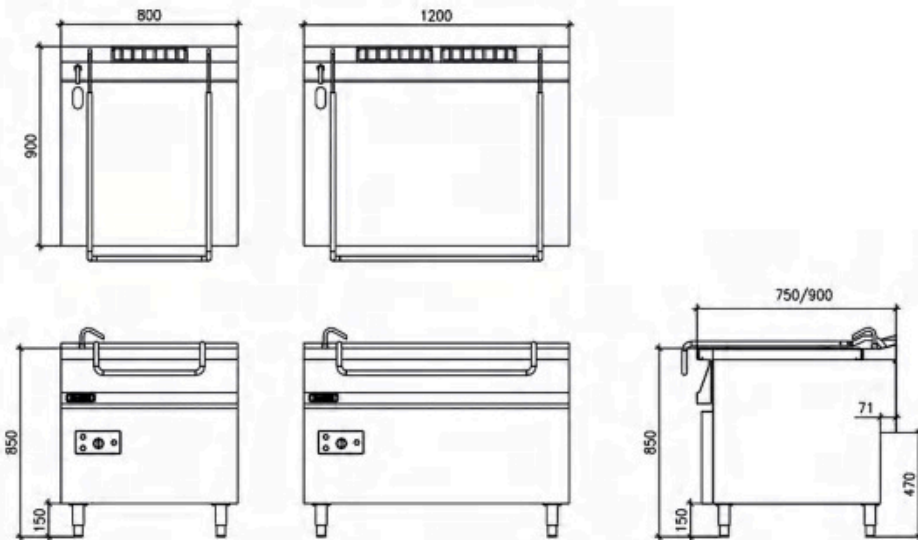

電熱西餐廚具系列

ELECTRIC WESTERN COOKING RANGE

產品特征
FEATURES

全不銹鋼機身結構；可調不銹鋼腳，放置平穩
採用 SUS 304#2.0 mm 厚工作臺面，整體衝壓成型
18mm 厚的磨砂精鋼扒板，下沈式的耐熱鋼機板無縫焊接在臺面上；配置抽拉式活動的盛油盆，易於油脂收集及清潔；設置隔熱板和擋火板，提高熱效率，防止外部過熱
恆溫控制，60°C~300°C可調；設置420°C超溫保護，可手動復位

Completely SS body. One punched worktop with 2mm thickness.
Adjustable SS feet convenient for install. 18mm heating board made by premium stainless steel and full welding with the worktop.
Equipped with drawer type grease tray and drainage hole.
Set up heating insulation material to improve thermal efficiency and prevent external overheating
Adjustable temperature range 60°C-300°C, set up 420°C over temperature protection.

落地式電熱扒爐(750系列)
Floor Stand Electric Griddle



產品名稱 Product Name	型號 Model	規格(mm) Specification	電源 power supply	電量 quantity of electricity
電熱平扒爐下儲物櫃	M-LGRF4N-E	400*750*850	380V/50Hz	4.5kW
電熱平扒爐下儲物櫃	M-LGRF8N-E	800*750*850	380V/50Hz	9kW
電熱平扒爐下儲物櫃	M-LGRF12N-E	1200*750*850	380V/50Hz	13.5kW
電熱坑扒爐下儲物櫃	M-LGRP4N-E	400*750*850	380V/50Hz	4.5kW
電熱坑扒爐下儲物櫃	M-LGRP8N-E	800*750*850	380V/50Hz	9kW
電熱坑扒爐下儲物櫃	M-LGRP12N-E	1200*750*850	380V/50Hz	13.5kW
電熱1/3坑2/3平扒爐下儲物櫃	M-LGRPF8N-E	800*750*850	380V/50Hz	9kW
電熱1/3坑2/3平扒爐下儲物櫃	M-LGRPF12N-E	1200*750*850	380V/50Hz	13.5kW
電熱1/2坑1/2平扒爐下儲物櫃	M-LGRPF8N-E	800*750*850	380V/50Hz	9kW
電熱1/2坑1/2平扒爐下儲物櫃	M-LGRPF12N-E	1200*750*850	380V/50Hz	13.5kW
電熱平扒爐下焗爐	M-LGRF8N-O-E	800*750*850	380V/50Hz	9+6kW
電熱平扒爐下焗爐	M-LGRF12N-O-E	1200*750*850	380V/50Hz	13.5+6kW
電熱坑扒爐下焗爐	M-LGRP8N-O-E	800*750*850	380V/50Hz	9+6kW
電熱坑扒爐下焗爐	M-LGRP12N-O-E	1200*750*850	380V/50Hz	13.5+6kW
電熱1/3坑2/3平扒爐下焗爐	M-LGRPF8N-O-E	800*750*850	380V/50Hz	9+6kW
電熱1/3坑2/3平扒爐下焗爐	M-LGRPF12N-O-E	1200*750*850	380V/50Hz	13.5+6kW
電熱1/2坑1/2平扒爐下焗爐	M-LGRPF8N-O-E	800*750*850	380V/50Hz	9+6kW
電熱1/2坑1/2平扒爐下焗爐	M-LGRPF12N-O-E	1200*750*850	380V/50Hz	13.5+6kW

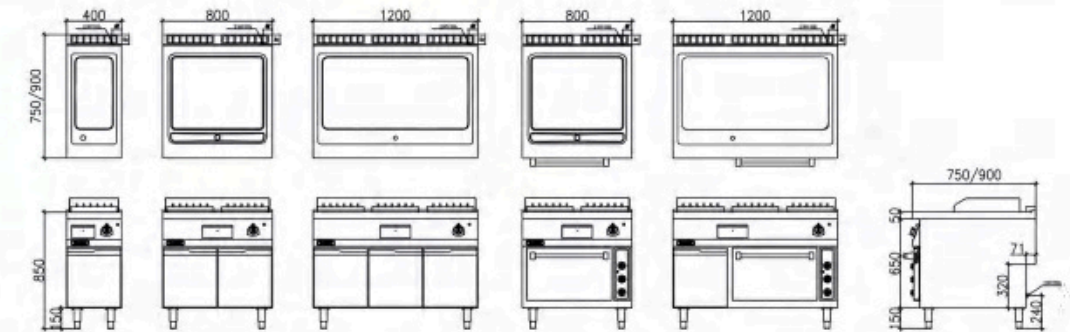

選配下焗爐帶字母O表示;選配平扒帶字母F表示;選配坑扒帶字母P表示;選配半平半坑帶字母PF表示

The oven represented by the "O"; Choose smooth griddle represented by the "F"; Choose groove griddle represented by the "P"; Choose half smooth and half groove griddle represented by the "PF".

電熱型西餐爐具系列 | Electric western cooking range

產品特征
FEATURES

全不銹鋼機身結構；可調不銹鋼腳，放置平穩
採用 SUS 304#2.0 mm 厚工作臺面，整體衝壓成型
18mm 厚的磨砂精鋼扒板，下沈式的耐熱鋼機板無縫焊接在臺面上；配置抽拉式活動的盛油盆，易於油脂收集及清潔；設置隔熱板和擋火板，提高熱效率，防止外部過熱
恆溫控制，60°C~300°C可調；設置420°C超溫保護，可手動復位

Completely SS body. One punched worktop with 2mm thickness.
Adjustable SS feet convenient for install. 18mm heating board made by premium stainless steel and full welding with the worktop.
Equipped with drawer type grease tray and drainage hole. Set up heating insulation material to improve thermal efficiency and prevent external overheating
Adjustable temperature range 60°C-300°C, set up 420°C over temperature protection.

落地式電熱扒爐(900系列)
Floor Stand Electric Griddle



產品名稱 Product Name	型號 Model	規格(mm) Specification	電源 power supply	電量 quantity of electricity
電熱平扒爐下儲物櫃	M-LGRF4H-E	400*900*850	380V/50Hz	6kW
電熱平扒爐下儲物櫃	M-LGRF8H-E	800*900*850	380V/50Hz	9kW
電熱平扒爐下儲物櫃	M-LGRF12H-E	1200*900*850	380V/50Hz	18kW
電熱坑扒爐下儲物櫃	M-LGRP4H-E	400*900*850	380V/50Hz	6kW
電熱坑扒爐下儲物櫃	M-LGRP8H-E	800*900*850	380V/50Hz	9kW
電熱坑扒爐下儲物櫃	M-LGRP12H-E	1200*900*850	380V/50Hz	18kW
電熱1/3坑2/3平扒爐下儲物櫃	M-LGRPF8H-E	800*900*850	380V/50Hz	9kW
電熱1/3平2/3坑扒爐下儲物櫃	M-LGRPF12H-E	1200*900*850	380V/50Hz	18kW
電熱1/2平1/2坑扒爐下儲物櫃	M-LGRPF8H-E	800*900*850	380V/50Hz	9kW
電熱1/2平1/2坑扒爐下儲物櫃	M-LGRPF12H-E	1200*900*850	380V/50Hz	18kW
電熱平扒爐下焗爐	M-LGRF8H-O-E	800*900*850	380V/50Hz	9+6kW
電熱平扒爐下焗爐	M-LGRF12H-O-E	1200*900*850	380V/50Hz	18+6kW
電熱坑扒爐下焗爐	M-LGRP8H-O-E	800*900*850	380V/50Hz	9+6kW
電熱坑扒爐下焗爐	M-LGRP12H-O-E	1200*900*850	380V/50Hz	18+6kW
電熱2/3平1/3坑扒爐下焗爐	M-LGRPF8H-O-E	800*900*850	380V/50Hz	9+6kW
電熱2/3平1/3坑扒爐下焗爐	M-LGRPF12H-O-E	1200*900*850	380V/50Hz	18+6kW
電熱1/2平1/2坑扒爐下焗爐	M-LGRPF8H-O-E	800*900*850	380V/50Hz	9+6kW
電熱1/2平1/2坑扒爐下焗爐	M-LGRPF12H-O-E	1200*900*850	380V/50Hz	18+6kW

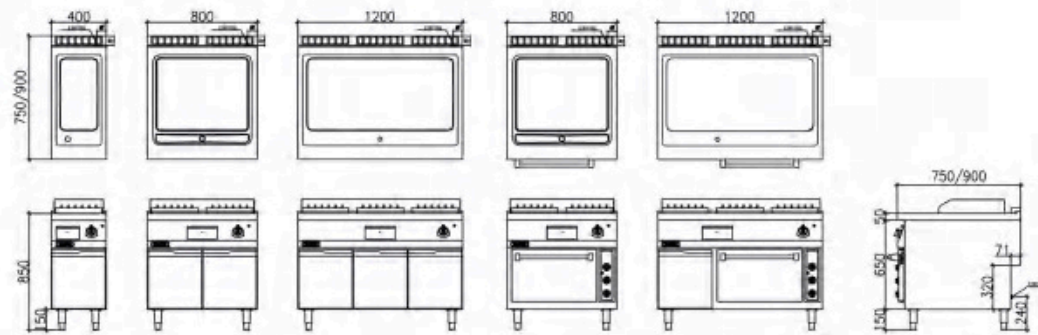

選配下焗爐帶字母O表示;選配平扒帶字母F表示;選配坑扒帶字母P表示;選配半平半坑帶字母PF表示

The oven represented by the "O"; Choose smooth griddle represented by the "F"; Choose groove griddle represented by the "P"; Choose half smooth and half groove griddle represented by the "PF".

電熱型西餐爐具系列 | Electric western cooking range

產品特征
FEATURES

全不銹鋼機身結構；可調不銹鋼腳，放置平穩
採用 SUS 304#2.0 mm 厚工作臺面，整體衝壓成型
18mm 厚的磨砂精鋼扒板，下沈式的耐熱鋼機板無縫焊接在臺面上；配置抽拉式活動的盛油盆，易於油脂收集及清潔；設置隔熱板和擋火板，提高熱效率，防止外部過熱
恆溫控制，60°C~300°C可調；設置420°C超溫保護，可手動復位

Completely SS body. One punched worktop with 2mm thickness.
Adjustable SS feet convenient for install.
Adjustable power of EGO heating plate, the cool fan device had installed bottom.
Set up self reset over temperature protection device.

落地式電熱平頭爐(圓形)
Floor Stand Electric Range With Hot Plate(round)



產品名稱 Product Name	型號 Model	規格(mm) Specification	電源 power supply	電量 quantity of electricity
電熱雙頭平頭爐下儲物櫃	M-LPF4N-E	400*750*850	220V/50Hz	4.6kW
電熱四頭平頭爐下儲物櫃	M-LPF8N-E	800*750*850	380V/50Hz	9.2kW
電熱六頭平頭爐下儲物櫃	M-LPF12N-E	1200*750*850	380V/50Hz	13.8kW
電熱雙頭平頭爐下儲物櫃	M-LPF4H-E	400*900*850	220V/50Hz	5.2kW
電熱四頭平頭爐下儲物櫃	M-LPF8H-E	800*900*850	380V/50Hz	10.4kW
電熱六頭平頭爐下儲物櫃	M-LPF12H-E	1200*900*850	380V/50Hz	15.6kW
電熱四頭平頭爐下焗爐	M-LPF8N-O-E	800*750*850	380V/50Hz	15.2kW
電熱六頭平頭爐下焗爐	M-LPF12N-O-E	1200*750*850	380V/50Hz	19.8kW
電熱四頭平頭爐下焗爐	M-LPF8H-O-E	800*900*850	380V/50Hz	16.4kW
電熱六頭平頭爐下焗爐	M-LPF12H-O-E	1200*900*850	380V/50Hz	21.6kW

落地式電熱平頭爐(方形)
Floor standing electric flat head furnace (square)



產品名稱 Product Name	型號 Model	規格(mm) Specification	電源 power supply	電量 quantity of electricity
電熱雙頭平頭爐下儲物櫃	M-LPF4FH-E	400x900x850	220V/50Hz	4x2=8kW
電熱四頭平頭爐下儲物櫃	M-LPF8FH-E	800x900x850	380V/50Hz	4x4=16kW
電熱六頭平頭爐下儲物櫃	M-LPF12FH-E	1200x900x850	380V/50Hz	4x6=24kW

選配下焗爐帶字母O表示
The oven represented by the "O"

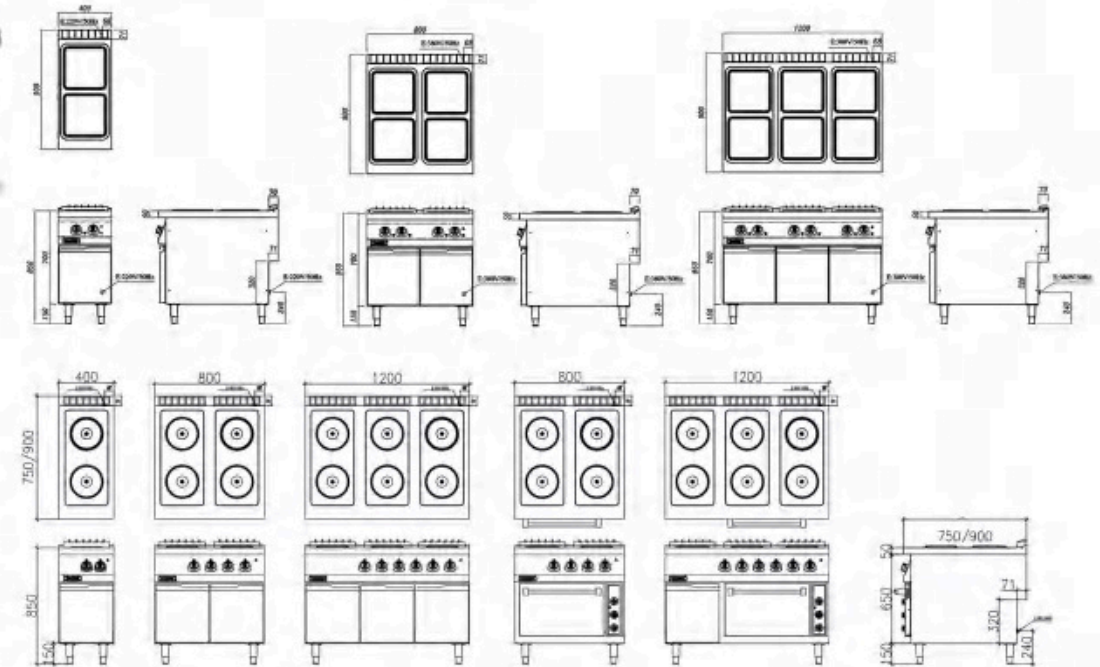

產品特征
FEATURES

全不銹鋼機身結構；可調不銹鋼腳，放置平穩
採用 SUS 304#2.0 mm 厚工作臺面，整體衝壓成型
配置抽拉式活動的盛油盆，易於油脂收集及清潔
三面防濺擋板可通過不銹鋼的搭扣完全拆卸
獨特的可調節角度耐火鑄造搪瓷燒烤架，防止燒烤殘
油汙染食物
通過發熱管傳達過熱量，多檔火力控制功能

Completely SS body. One punched worktop with 2mm thickness.
Adjustable SS feet convenient for install.
Equipped with drawer type grease tray and drainage hole, convenient for collected grease and easily clean.
Adopted premium heating elements, multi heating power for options.
Set up removable splash guards around the grid
Adopted adjustable angle cast iron grid to prevent the grease polluting the food.

落地式電熱燒烤爐
Floor stand electric grill



產品名稱 Product Name	型號 Model	規格(mm) Specification	電源 power supply	電量 quantity of electricity
電熱燒烤爐下儲物櫃	M-LBS4N-E	400*750*850	380V, 50Hz	4.5kW
電熱燒烤爐下儲物櫃	M-LBS8N-E	800*750*850	380V/50Hz	9.0kW
電熱燒烤爐下儲物櫃	M-LBS12N-E	1200*750*850	380V/50Hz	13.5kW
電熱燒烤爐下儲物櫃	M-LBS4H-E	400*900*850	380V/50Hz	6.0kW
電熱燒烤爐下儲物櫃	M-LBS8H-E	800*900*850	380V/50Hz	12.0kW
電熱燒烤爐下儲物櫃	M-LBS12H-E	1200*900*850	380V/50Hz	18.0kW

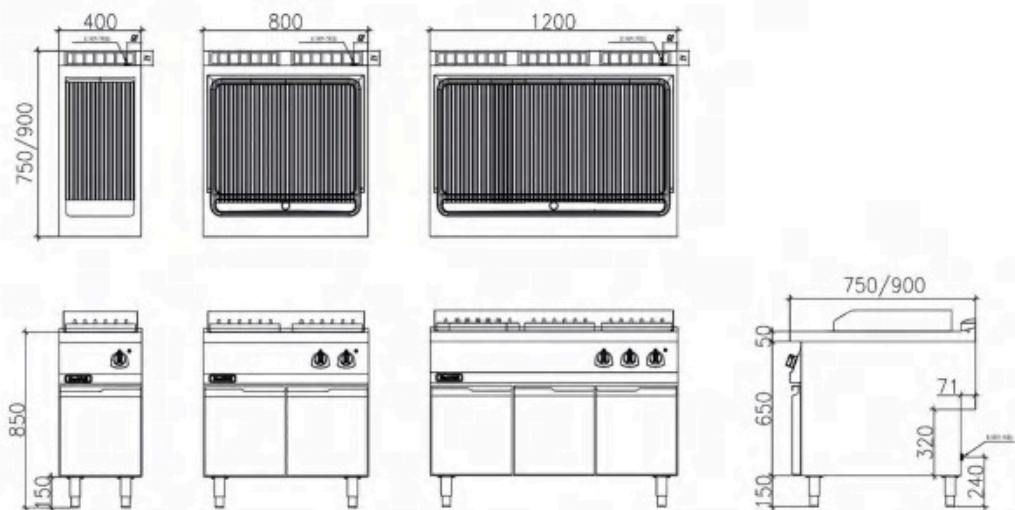

產品特征
FEATURES

全不銹鋼機身結構
可調不銹鋼腳，放置平穩
採用SUS304#2.0mm厚工作臺面，整體衝壓成型
新型深沖壓式炸缸（18L）
放油閥設置自鎖裝置，防止誤操作
帶有235°C超溫安全裝置，可手動復位
EGO溫控器，溫度調節60°C~190°C

Completely SS body, One punched worktop with 2mm thickness.
Adjustable SS feet convenient for install.
Deep punched tank (18L) with V-type cold area for store residues.
Oil drainage had equipped with self lock device to prevent the misoperation.
EGO temperature controller and temperature range: 60°C~190°C. Equipped with over temperature protection (230°C) with manual reset.

落地式電熱炸爐
Floor stand electric deep fryer



產品名稱 Product Name	型號 Model	規格(mm) Specification	電源 power supply	電量 quantity of electricity
電熱單缸炸爐下儲物櫃	M-LBF4N-E	400*750*850	380V, 50Hz	9kW
電熱雙缸炸爐下儲物櫃	M-LBF8N-E	800*750*850	380V/50Hz	18kW
電熱單缸炸爐下儲物櫃	M-LBF4H-E	400*900*850	380V/50Hz	9kW
電熱雙缸炸爐下儲物櫃	M-LBF8H-E	800*900*850	380V/50Hz	18kW
電熱單缸自動升降炸爐	M-LBFU4H-E	550*900*850	380V/50Hz	18kW
電熱雙缸自動升降炸爐	M-LBFU8H-E	1050*900*850	380V/50Hz	36kW
電熱工業炸爐下儲物櫃	M-LBFL8N-E	800*750*850	380V, 50Hz	36kW
電熱工業炸爐下儲物櫃	M-LBFL8H-E	800*900*850	380V, 50Hz	36kW

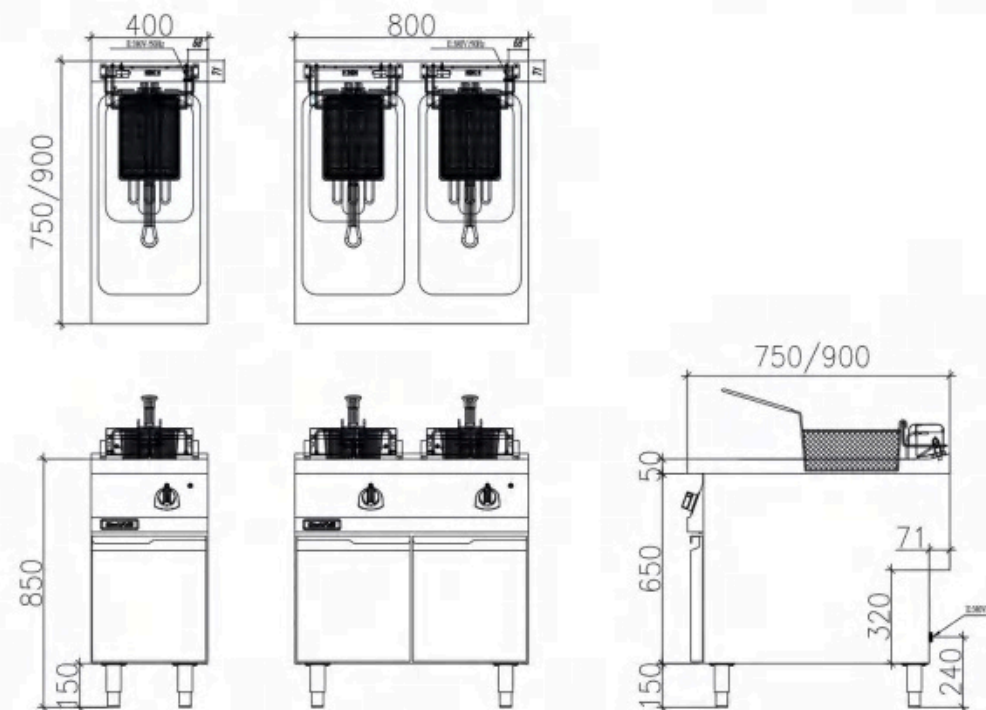

產品特征
FEATURES

全不銹鋼機身結構；可調不銹鋼腳，放置平穩
採用 SUS 304#2.0 mm 厚工作臺面，整體衝壓成型
沸騰水泡自動爆散麵團。並防止沸水濺溢
設置溢水槽，自動補水裝置
煮面缸容量大（900系列35L，750系列25L）升溫速度快
設置缺水保護，防止發熱管幹燒
煮面缸容量大，溫度恒定；高效發熱線，三擋快、中、慢火力調節

Completely SS body, One punched worktop with 2mm thickness.
Adjustable SS feet convenient for install.
Automatic refilling water, set
Automatic devided noodle dough by the boiled water bubble.
equipped with overflowing device and big capacity basket(900 series:35L, 750 series:25L).
Premium heating elements with power adjust switcher.
Set up water lack protection to prevent dry heating.

落地式電熱意粉爐
Floor stand electric pasta cooker



產品名稱 Product Name	型號 Model	規格(mm) Specification	電源 power supply	電量 quantity of electricity
電熱意粉爐下儲物櫃	M-LSF4N-E	400*750*850	380V, 50Hz	7.5kW
電熱意粉爐下儲物櫃	M-LSF8N-E	800*750*850	380V/50Hz	15kW
電熱意粉爐下儲物櫃	M-LSF4H-E	400*900*850	380V/50Hz	9kW
電熱意粉爐下儲物櫃	M-LSF8H-E	800*900*850	380V/50Hz	18kW

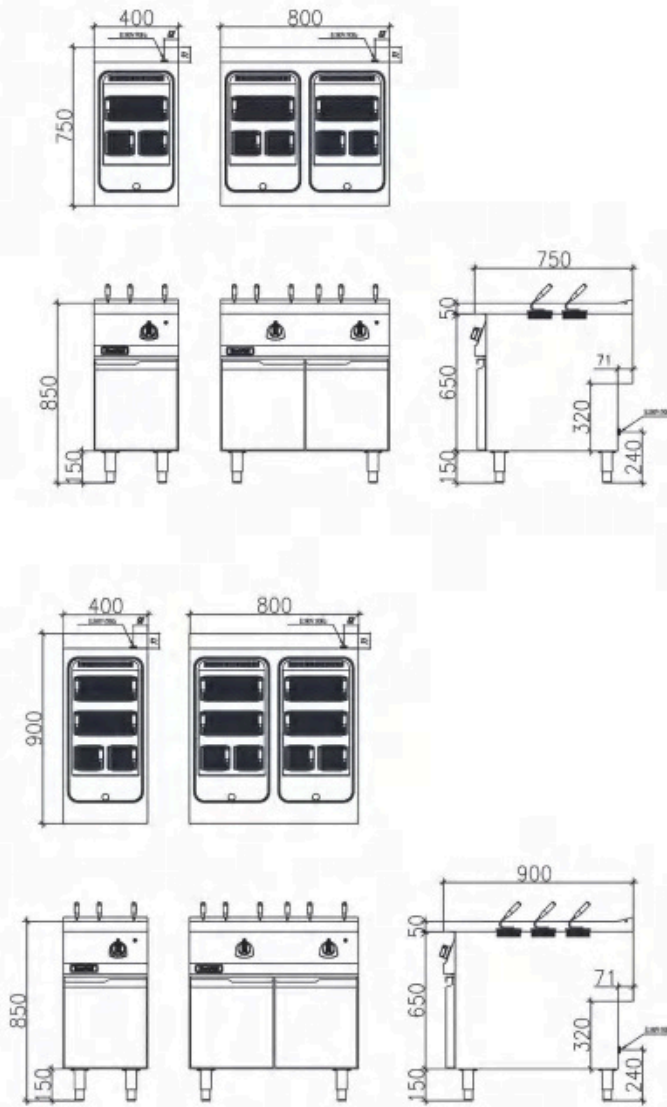

產品特征
FEATURES

全不銹鋼機身結構；可調不銹鋼腳，放置平穩
採用 SUS 304#2.0 mm 厚工作臺面，整體衝壓成型
沸騰水泡自動爆散麵團。並防止沸水濺溢
設置溢水槽，自動補水裝置
煮面缸容量大（900系列35L，750系列25L）升溫速度快
設置缺水保護，防止發熱管幹燒
煮面缸容量大，溫度恒定；高效發熱線，三擋快、中、慢火力調節

Completely SS body, One punched worktop with 2mm thickness.
Adjustable SS feet convenient for install.
Automatic refilling water
Automatic devided noodle dough by the boiled water bubble.
Equipped with overflowing device and big capacity basket(900 series:35L, 750 series:25L).
Premium heating elements with power adjust switcher.
Set up water lack protection to prevent dry heating.

落地式電熱煮面爐
Floor stand electric noodle boiler



產品名稱 Product Name	型號 Model	規格(mm) Specification	電源 power supply	電量 quantity of electricity	備註 notes
電熱單缸煮面爐下儲物櫃	M-LPC4N-E	400*750*850	380V, 50Hz	7.5kW	配煮面篩
電熱單缸煮面爐連冷水盆下儲物櫃	M-LPC8N-E	800*750*850	380V/50Hz	7.5kW	配煮面篩
電熱雙缸煮面爐下儲物櫃	M-LPC8N2-E	800*750*850	380V/50Hz	15kW	配煮面篩
電熱單缸煮面爐下儲物櫃	M-LPC4H-E	400*900*850	380V/50Hz	9kW	配煮面篩
電熱單缸煮面爐連冷水盆下儲物櫃	M-LPC8H-E	800*900*850	380V, 50Hz	9kW	配煮面篩
電熱雙缸煮面爐下儲物櫃	M-LPC8H2-E	800*900*850	380V, 50Hz	18kW	配煮面篩
升降式六頭煮面爐	M-LPCU6N-E	600*750*850	380V, 50Hz	8kW	配6個煮面篩
升降式六頭煮面爐	M-LPCU6H-E	600*900*850	380V, 50Hz	9kW	配6個煮面篩

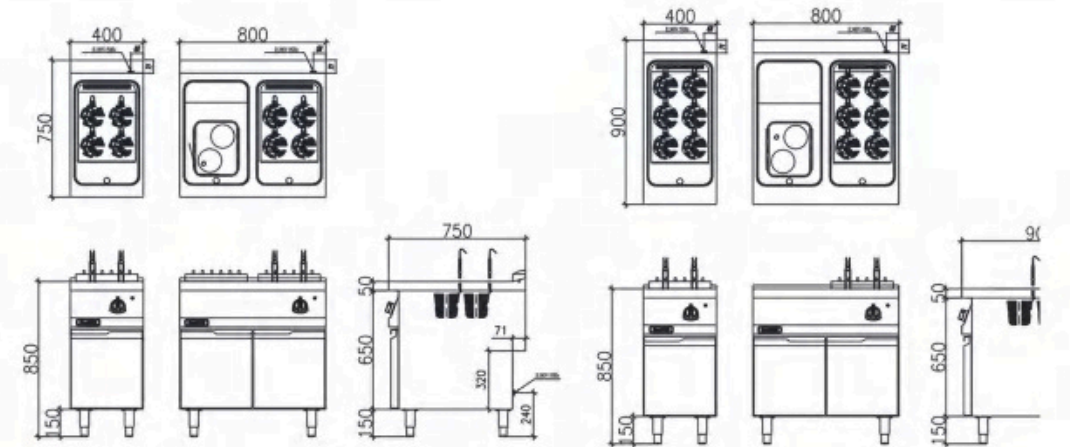

電熱型西餐爐具系列 | Electric western cooking range

產品特征
FEATURES

全不銹鋼機身結構
可調不銹鋼腳，放置平穩
採用 SUS 304#1.5 mm 厚工作臺面，整體衝壓成型和
工作面無縫焊接以方便清潔
可放置多種規格GN盤
可通過控制面板上的按鈕進行手動加水

Completely SS body, One punched worktop with 2mm thickness and convenient for clean.
Adjustable SS feet convenient for install.
Can be placed kinds of specification GN pans. manual filling water by control button.

落地式電熱保溫湯池
Floor stand electric bain marie

產品名稱 Product Name	型號 Model	規格(mm) Specification	電源 power supply	電量 quantity of electricity
電熱單缸保溫湯池下儲物櫃	M-LWP4N-E	400*750*850	220V/50Hz	3kW
電熱雙缸保溫湯池下儲物櫃	M-LWP8N-E	800*750*850	220V/50Hz	6kW
電熱單缸暖湯池下儲物櫃	M-LWP4H-E	400*900*850	220V/50Hz	3kW
電熱雙缸暖湯池下儲物櫃	M-LWP8H-E	800*900*850	220V/50Hz	6kW

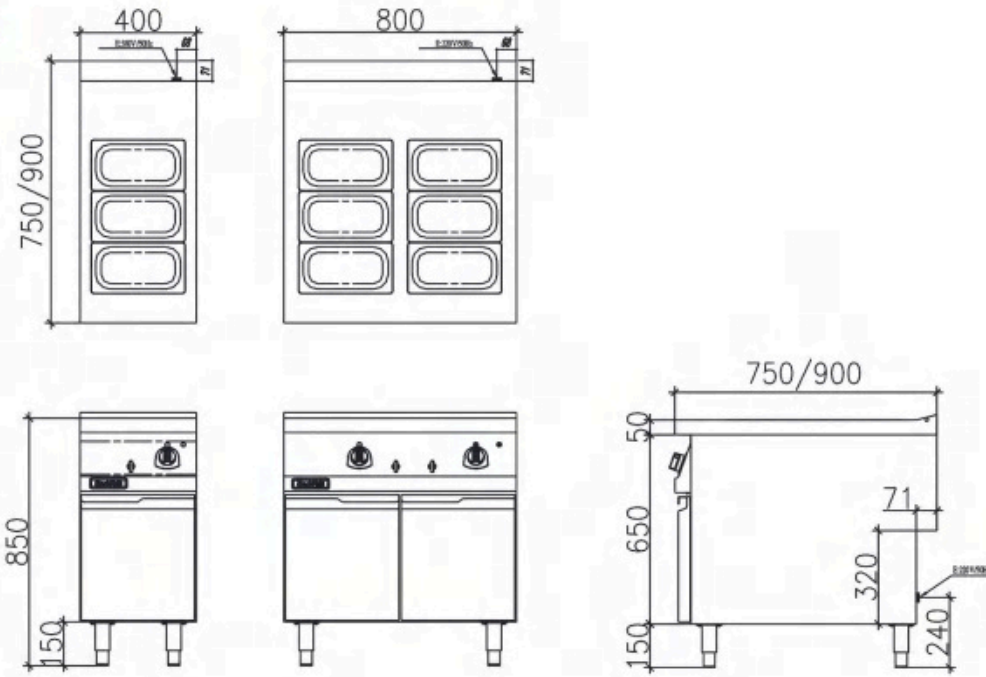

電熱型西餐爐具系列 | Electric western cooking range

產品特征
FEATURES

全不銹鋼機身結構；可調不銹鋼腳，放置平穩
採用 SUS 304#1.5 mm 厚工作臺面，整體衝壓成型
多種保護裝置，缺水、保溫、過流保護等
進水箱和蒸汽發生器獨立設計
壓力平衡式自動補水箱，保證水膽水位平衡
多段功率選擇，可隨客戶選擇開放1組或多組加熱
硬水地區使用該設備必須裝配軟化水設置

Completely SS body, One punched worktop with 1.5mm thickness and convenient for clean.
Adjustable SS feet convenient for install.
Set up water lack protection, over temperature protection, over current protection and so on.
Independently designed water box and steam generator.
Automatic filling water device to keep the water level balance.
Kinds of heating power for options, can be choosed single group heating or multi group heating.
Required to install water softener for hard water areas

落地式電熱蒸爐
Floor stand electric steamer

產品名稱 Product Name	型號 Model	規格(mm) Specification	電源 power supply	電量 quantity of electricity
電熱單頭蒸爐連下儲物櫃	M-LCSE8N-E	800*750*850	380V/50Hz	27kW
電熱單頭蒸爐連下儲物櫃	M-LCSE8H-E	800*900*850	380V/50Hz	27kW
電熱雙頭蒸爐連下儲物櫃	M-LCSE16H-E	1600*900*850	380V/50Hz	27kW

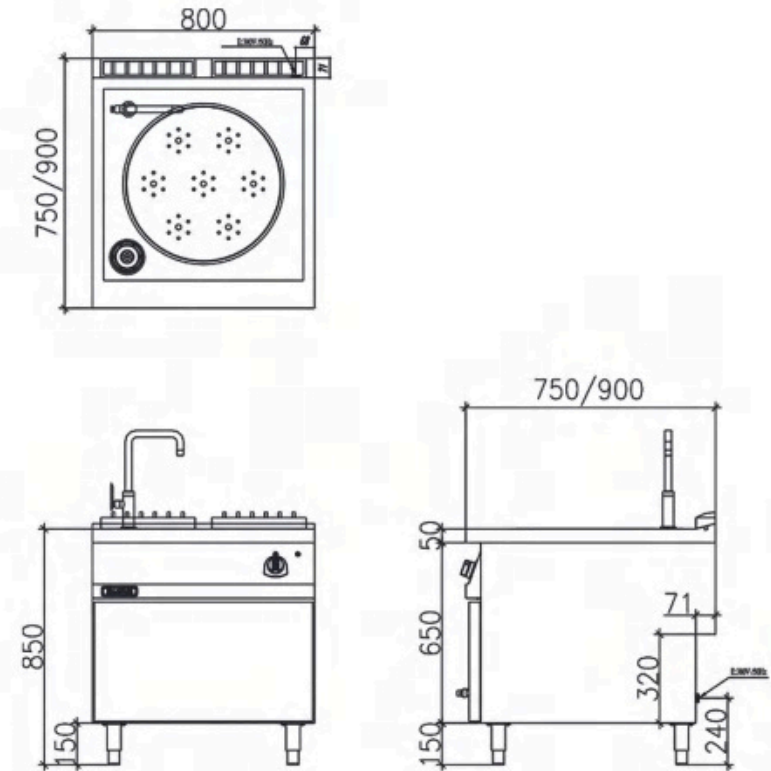

電熱型西餐爐具系列 | Electric western cooking range

產品特征
FEATURES

全不銹鋼機身結構；可調不銹鋼腳，放置平穩
雙層鍋體，鍋體為整體304不銹鋼拉伸，鏡面拋光
深沖壓式雙層鍋蓋；蒸汽對食物進行隔水加熱，避免食物粘底燒焦；設置超壓保護、超溫保護、缺水保護
達到排氣壓力時，安全閥自動排氣；自動或手動補充夾層軟水；設備配置安全泄氣閥，夾層壓大於0.06Mpa時開放，保證使用安全；設置真空減壓閥，調節腔內壓力，保證加熱過程中空氣的釋放

Completely SS body, Adjustable SS feet convenient for install.
Deeply Punched SUS #304 double jacket lid and body, indirect heating to avoid burnt food.
Automatic filling water or manual filling water for options. Equipped with over pressure protection, over temperature protection, water lack protection.
Relief valve automatic release the chamber steam pressure to ensure safety when pressure arrived 0.06Mpa.

落地式電熱湯鍋 FLOOR STAND ELECTRIC KETTLE



產品名稱 Product Name	西式電熱湯鍋 (80L)	西式電熱湯鍋 (100L)
型號 Model	M-WSP80-E	M-WSP100-E
規格(mm) Specification	800*900*850	800*900*850
熱負荷 Gas power	12kW	12kW
耗電量 Power consumption	380V,50Hz	380V,50Hz
進氣口 Gas inlet	DN20	DN20
進水口/排水口 Water inlet / outlet	DN15	DN15

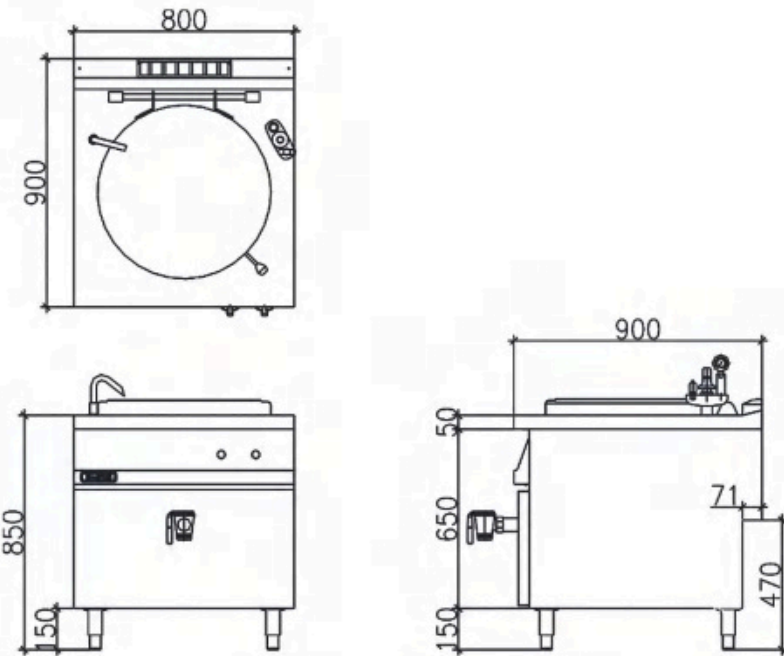

電熱型西餐爐具系列 | Electric western cooking range

產品特征
FEATURES

全不銹鋼機身結構
可調不銹鋼腳，放置平穩
不銹鋼雙層鍋蓋、圓角無縫焊接鍋體
電動傾斜，可超過90度
鍋底採用12mm厚的低碳鋼或復合鋼制成
恆溫控制，60°C~350°C可調

Completely SS body, Adjustable SS feet convenient for install.
Double jacket lid and inner bratt pan with round corner and full welding crafts.
Tilting angle over 90 degree
Adopted 12mm low-carbon steel or composite steel of the heating plate.
Adjustable temperature range 60°C-350°C

落地式電熱炒鍋 FLOOR STAND ELECTRIC BRATT PAN



產品名稱 Product Name	西式電熱炒鍋	西式電熱炒鍋
型號 Model	M-WFP8H-E	M-WFP12H-E
規格(mm) Specification	800*900*850	1200*900*850
熱負荷 Gas power	9kW	12kW
耗電量 Power consumption	380V,50Hz	380V,50Hz
進氣口 Gas inlet	DN20	DN20
進水口/排水口 Water inlet / outlet	DN15	DN15

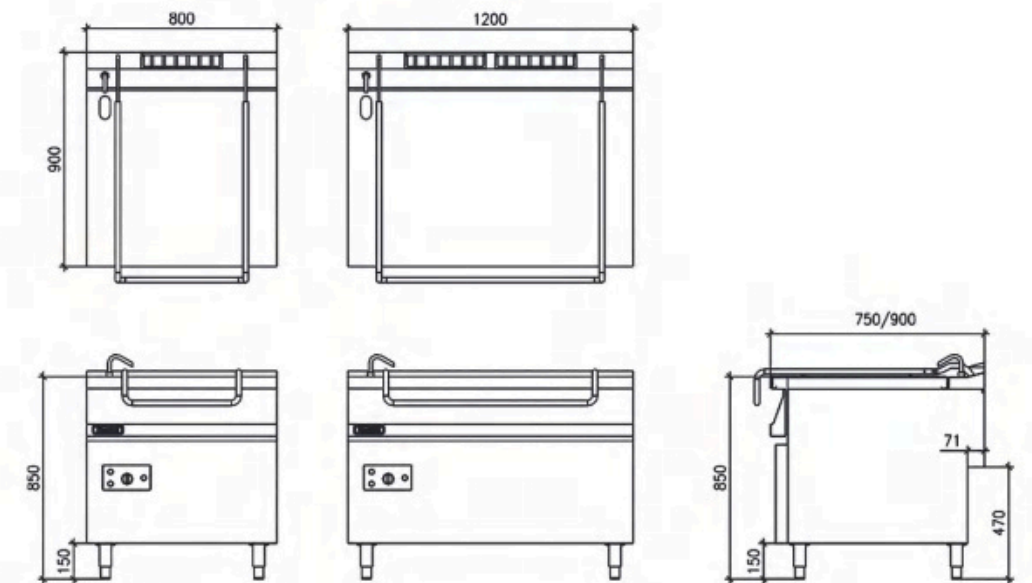

產品特征
FEATURES

全不銹鋼機身結構
模具拉伸成型炸缸(9L), 流線型設計, 易清洗, 不留任何死角
使用高性能扁圓截面油發熱管, 發熱管翻起結構, 行程開關自動斷電, 方便清潔
控溫器油溫控制範圍60°C-190°C
設有超溫保險開關(230°C)

All stainless steel body structure
Mold stretching forming explosive cylinder (9L), streamlined design, easy to clean, leaving no dead corners
Using high-performance flat circular section oil heating tube, the heating tube has a flipped structure, and the travel switch automatically cuts off power for easy cleaning
Temperature controller oil temperature control range: 60 °C -190 °C

座臺式電熱炸爐 Seat type electric fryer



型號 Model	M-TBF4N-E	M-TBF8N-E	M-TBFLN-E
規格(mm) Specification	350*700*290	650*700*290	500*700*290
熱負荷Gas power	6kW	6kW*2	4kW
耗電量 Power consumption	220V,50Hz	2-220V, 50Hz	380V, 50Hz
備註notes	配1個大炸篩	配2個大炸篩	



產品特征
FEATURES

全不銹鋼機身結構
840材質幹熱發熱線, 發熱均勻, 使用壽命長
EGO能量開關控制火力大小
配置抽拉式活動的盛油盆, 易於油脂收集及清潔
獨特的可調角度耐火鑄鐵搪瓷烤架, 防止燒烤殘油汙染食物
三面防濺擋板可通過不銹鋼的搭扣完整的拆卸

All stainless steel body structure
840 material dry heat heating wire, uniform heating, long service life
EGO energy switch controls firepower size
Equipped with a pull-out activity oil basin, easy to collect and clean grease
Unique adjustable angle refractory cast iron enamel barbecue rack to prevent food contamination from barbecue residue oil
-The three sided splash guard can be fully disassembled through stainless steel buckles

座臺式電熱燒烤爐 Seat type electric barbecue stove



型號 Model	M-TBS4N-E	M-TBS8N-E	M-TBS12N-E
規格(mm) Specification	400*700*290	800*700*290	1200*700*290
熱負荷Gas power	4.5kW	9.0kW	13.5kW
耗電量 Power consumption	380V, 50Hz	380V, 50Hz	380V, 50Hz

產品特征
FEATURES

全不銹鋼機身結構;
840材質幹熱發熱線, 發熱均勻, 使用壽命長、溫度高;
EGO溫控器調溫範圍100°C-300°C, 設有超溫保險開關(400°C);
厚度18mm低合金鋼扒板, 下沈式的耐熱鋼扒板無縫焊接在臺面上;
配置抽拉式活動的盛油盆, 易於油脂收集及清潔;
三面防濺擋板可通過不銹鋼的搭扣完整的拆卸;

All stainless steel body structure;
840 material dry heat heating wire, uniform heating, long service life, and high temperature;
The EGO temperature controller has a temperature range of 100 °C -300 °C and is equipped with an over temperature safety switch (400 °C);
18mm thick low alloy steel grating, sunken heat-resistant steel grating seamlessly welded on the countertop;
Equipped with a pull-out activity oil basin, easy to collect and clean grease;
The three sided splash guard can be fully disassembled through stainless steel buckles;

座臺式電熱扒爐
Seat type electric heating furnace



產品名稱 Product Name	型號 Model	規格(mm) Specification	電源 power supply	電量 quantity of electricity
座臺式電熱平扒爐	M-TGRF4N-E	400*700*290	380V, 50Hz	4.5kW
座臺式電熱平扒爐	M-TGRF6N-E	600*700*290	380V/50Hz	4.5kW
座臺式電熱平扒爐	M-TGRF8N-E	800*700*290	380V/50Hz	9kW
座臺式電熱平扒爐	M-TGRF12N-E	1200*700*290	380V/50Hz	13.5kW
座臺式電熱坑扒爐	M-TGRP4N-E	400*700*290	380V, 50Hz	4.5kW
座臺式電熱坑扒爐	M-TGRP6N-E	600*700*290	380V, 50Hz	4.5kW
座臺式電熱坑扒爐	M-TGRP8N-E	800*700*290	380V, 50Hz	9kW
座臺式電熱坑扒爐	M-TGRP12N-E	1200*700*290	380V, 50Hz	13.5kW
座臺式電熱半平半坑扒爐	M-TGRPF6N-E	600*700*290	380V/50Hz	4.5kW
座臺式電熱半平半坑扒爐	M-TGRPF8N-E	800*700*290	380V, 50Hz	9kW
座臺式電熱半平半坑扒爐	M-TGRPF12N-E	1200*700*290	380V, 50Hz	9kW
座臺式電熱1/3坑2/3平扒爐	M-TGRPF6N-E	600*700*290	380V, 50Hz	4.5kW
座臺式電熱1/3坑2/3平扒爐	M-TGRPF8N-E	800*700*290	380V, 50Hz	9kW
座臺式電熱1/3坑2/3平扒爐	M-TGRPF12N-E	1200*700*290	380V, 50Hz	9kW

產品特征
FEATURES

全不銹鋼機身結構
採用帶自動復位超溫保護裝置的EGO加熱爐盤
每個爐盤獨立控制, 可由快、中、慢三檔火力控制, 熱效率高
爐盤底有強風冷卻

All stainless steel body structure
Using EGO heating furnace disc with automatic reset over temperature protection device
Each furnace plate is independently controlled and can be controlled by three levels of firepower: fast, medium, and slow, with high thermal efficiency
Strong wind cooling at the bottom of the furnace tray

座臺式電熱平頭爐
Seat type electric flat head furnace



產品名稱 Product Name	型號 Model	規格(mm) Specification	電源 power supply	電量 quantity of electricity
座臺式電熱雙頭平頭爐	M-TPF4N-E	400*700*290	220V, 50Hz	4.6kW
座臺式電熱四頭平頭爐	M-TPF8N-E	800*700*290	380V/50Hz	9.2kW
座臺式電熱六頭平頭爐	M-TPF12N-E	1200*700*290	380V/50Hz	13.8kW

座臺式西餐爐具系列 | Countertop western cooking range

產品特征
FEATURES

全不銹鋼機身結構
設置缺水保護裝置，防止發熱管幹燒
高效率發熱線，三擋快、中、慢火力調節
不銹鋼格固定沸騰水泡自動爆散麵團並可防止沸水濺溢

Premium heating elements. Adjustable heating power.
Automatic devided noodle dough by the boiled water bubble.
Set up water lack protection to prevent dry heating.

座臺式電熱意粉爐 Countertop electric pasta cooker



型號 Model	M-TSF4N-E	M-TSF8N-E
規格(mm) Specification	400*700*290	800*700*290
熱負荷Gas power	7.5kW	7.5kW*2
耗電量 Power consumption	380V,50Hz	380V,50Hz
備註notes	配意粉籃	配意粉籃

產品特征
FEATURES

全不銹鋼機身結構
高效發熱線，三檔火力調節
沸騰水泡自動爆散麵團並可防止沸水濺溢；
設置溢水槽，一鍵補水裝置
設置缺水保護，防止發熱管幹燒，安全控制更可靠

All stainless steel body structure
Efficient heating line, three level firepower regulation
Boiling water bubbles automatically disperse dough and prevent boiling water from splashing over;
Set up overflow tank and one click water replenishment device
Set up water shortage protection to prevent dry burning of heating pipes, ensuring more reliable safety control

座臺式電熱意粉爐 Countertop electric pasta cooker



型號 Model	M-TPC4N-E	M-TPC8N-E
規格(mm) Specification	400*700*290	800*700*290
熱負荷Gas power	7.5kW	7.5kW*2
耗電量 Power consumption	380V,50Hz	380V,50Hz
備註notes	配煮面篩	配煮面篩

產品特征
FEATURES

全不銹鋼機身結構
缸體與工作面無縫焊接以方便清潔
可防止多種規格GN盤
可通過控制面板上的按鈕進行手動加水

Completely SS body, The tank full welding with worktop.
Can be placed kinds of specification GN pans.
Manual filling water by control button.

座臺式電熱保溫湯池 Countertop electric bain marie



型號 Model	M-TWP4N-E	M-TWP8N-E
規格(mm) Specification	400*700*290	800*700*290
熱負荷Gas power	3kW	3kW*2
耗電量 Power consumption	380V,50Hz	380V,50Hz
備註notes	配3個1/3GN盤	配3個1/3GN盤

座臺式西餐爐具系列 | Countertop western cooking range

產品特征
FEATURES

采用全不銹鋼機身結構
通過熱源對食物表面進行加熱，電和燃氣產生紅外光線，從爐體內上方向下進行加熱，避免燒烤油渣與火接觸燃燒產生有害物質，保持食物的鮮美
烤架可調節，輕鬆調節面板與加熱食物之間的距離，確保食物的質量
底部設置盛油盆，方便剩載食物中留下的油汙物

All stainless steel body structure; adjustable stainless steel feet, stable placement
Set heat shield and fire baffle to improve thermal efficiency and prevent external overheating
Set up long-term open flame; configure safety system (thermocouple flameout protection device)
Automatic pulse electronic ignition with linkage with safety system The central part of the hot plate conducts heat centrally, the surface temperature of the hot plate is evenly distributed and the temperature rises rapidly
The fire switch controls the double circle furnace head, which can open the outer ring fire and the inner ring fire respectively as required

掛牆式電熱面火爐 Wall Mounted Electric Salamander



型號 Model	M-TSM6N-E
規格(mm) Specification (mm)	650x510x467
額定電壓 Rated voltage	220V, 50Hz
額定功率 Rated power	4.6kW
備註 Remarks	

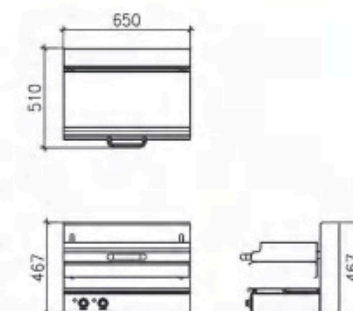

座臺式電熱面火爐 COUNTERTOP electric salamander



型號 Model	M-TSMK7N-E
規格(mm) Specification (mm)	800x460x470
額定電壓 Rated voltage	220V, 50Hz
額定功率 Rated power	6kW
備註 Remarks	

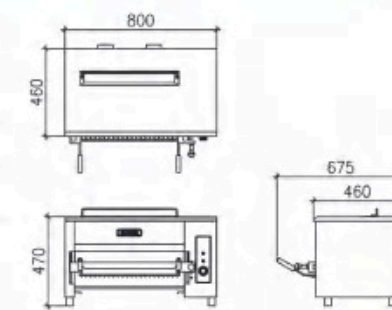

座臺式燃氣面火爐 COUNTERTOP gas salamander



型號 Model	M-TSMK7N-G
規格(mm) Specification (mm)	800x460x470
熱負荷 Gas power	7.5kW
進氣口 Gas inlet	DN20
備註 Remarks	

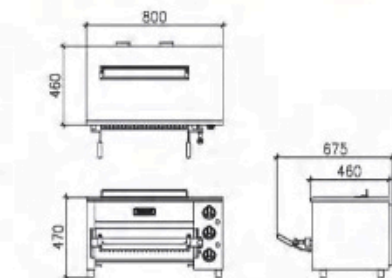

中餐爐具系列 節能環保 安全可靠

CHINESE COOKING RANGE

ENVIRONMENTAL FRIENDLY, SAFETY & RELIABILITY



不同的中式爐具安裝

INSTALLATION OF DIFFERENT CHINESE STOVES //



常規式中式爐具 Product characteristics



產品特征 PRODUCT CHARACTERISTICS

兩臺設備之間的連接採用卡條連接方式，防止水流入；面板表面無固定螺釘整體無焊接臺面，薄邊設計；全不銹鋼鍍金框架；壹鍵式電子點火；火力大小調節閥
整體爐磚·防止漏火損壞爐膛適合炒菜拋鍋結構布局鍋底溫度均勻‘熄火保護、控制系統採用集成模塊安裝方式、標準、規範進水閥控制開關；採用新型風機、體積小風量大、噪音低

Equipments are clipped together by u-channel connector for water proof . One piece table top without welding, hygiene and easily for cleaning, .Completely SUS304 stainless steel frame structure with riveted fix. One-button control blower, electronic pulse ignition and ion detector flame failure protection. A monolithic brick, avoid damaging the chamber by the leaked fire. control system adopted standard modular structure. Innovation blower with small volume and high flowing ,low noise.



地臺式中式爐具 Floor type Chinese stove



從細節做起 Start with details

可選配件
Accessories



凍水盤(選配)
Freezing pan(Optional)



調料臺(標配)
Seasoning Board (Standard)



鍋枕(標配)
Pot pillow (standard)



籃球架(標配)
Basketball stands (standard)

產品特征
FEATURES

臺面整件成型，方便清潔；
隔熱臺面，5mm硅酸鋁面棉；
爐頭內冷的氣體吸收爐頭外殼熱量，降低爐頭溫度，提高爐頭的使用壽命；
整體爐磚，防止漏火損壞爐體；
感應針使用溫度超過 1200度，不易燒壞。

One punched worktop and 5mm aluminum silicate surface at the bottom, convenient for clean. Pre mixed burner, cold air decrease burner outer shell temperature, improve the running time. A monolithic brick, avoid damaging the chamber by the leaked fire. Thermocouple service temperature is over than 1200 degree, difficult to be damaged

燃氣炒爐系列(4寸環保爐頭系列) Gas fryer series (4-inch environmentally friendly stove head series)



產品名稱 Product Name	型號 Model	規格(mm) Specification	熱負荷 Gas power	風機 Blower	進氣口 Gas inlet	進水口/排水口 Water inlet / outlet
燃氣環保單頭單尾炒爐	SZCT42-CRE-1-N(E)	1200*1050*810+440	42kW	220V, 50Hz, 130W	DN20	DN15/DN40
燃氣環保雙頭單尾炒爐	SZCT42/84-CRE-2-1N(E)	1800*1050*810+440	84kW	220V, 50Hz, 130Wx2	DN40	DN15/DN40
燃氣環保雙頭雙尾炒爐	SZCT42/84-CRE-2-N(E)	2100*1050*810+440	84kW	220V, 50Hz, 130Wx2	DN40	DN15/DN40
燃氣環保單頭單尾炒爐	SZCT42-CRE-1-G(E)	1200*1200*810+440	42kW	220V, 50Hz, 130W	DN20	DN15/DN40
燃氣環保雙頭單尾炒爐	SZCT42/84-CRE-2-1G(E)	1800*1200*810+440	84kW	220V, 50Hz, 130Wx2	DN40	DN15/DN40
燃氣環保雙頭雙尾炒爐	SZCT42/84-CRE-2-G(E)	2100*1200*810+440	84kW	220V, 50Hz, 130Wx2	DN40	DN15/DN40

型號(E)表示帶電磁安全制

(E) Represent electromagnetic valve safety device

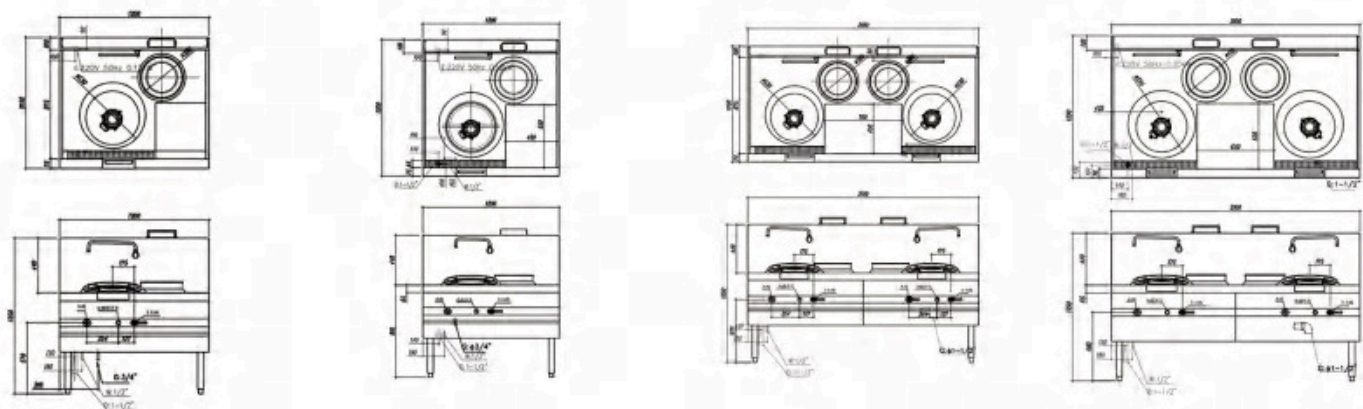

產品特征
FEATURES

採用燃燒控制器分步控制電磁閥，火種未點燃時，主氣閥不會打開；
風機供風不正常，供氣不正常，意外熄火等故障，1秒鐘關閉燃氣，壹鍵式 風機、電子打火和離子熄火保護設計。
鼓風預混燃燒，噪音小於65分貝，燃燒充分，壹氧化碳排放量小於 0.01%；
燃氣和空氣混合燃燒充分，火力猛勁，熱效率高。與壹般滿風爐頭相比可節能30%以上。
每個爐頭獨立配置風機，使用行鏈風制 實現風氣聯動開關，可調節供風大小。

Stepwise controlled by duplex solenoid valve, the main gas valve doesn't open until the fire ignites. As will be cut off in 1 second once the air or gas is supplying abnormally. One-button control blower, electronic pulse ignition and ion detector flame failure protection. Blast premixing combustion, heavy power, combustion noise < 65dB, the emission of carbon monoxide < 0.01%, energy saving more than 30% to compare with other blower burner. Each burner had equipped with blower, adopted chain wind system adjust the air and gas supply at the same time.

燃氣炒爐系列(5寸環保爐頭系列) Gas fryer series (5-inch environmentally friendly stove head series)



產品名稱 Product Name	型號 Model	規格(mm) Specification	熱負荷 Gas power	風機 Blower	進氣口 Gas inlet	進水口/排水口 Water inlet / outlet
燃氣環保單頭單尾炒爐	SZCT48-CRE-1-N(E)5	1200*1050*810+440	48kW	220V, 50Hz, 130W	DN20	DN15/DN40
燃氣環保雙頭單尾炒爐	SZCT48/96-CRE-2-1N(E)5	1800*1050*810+440	96kW	220V, 50Hz, 130Wx2	DN40	DN15/DN40
燃氣環保雙頭雙尾炒爐	SZCT48/96-CRE-2-N(E)5	2100*1050*810+440	96kW	220V, 50Hz, 130Wx2	DN40	DN15/DN40
燃氣環保單頭單尾炒爐	SZCT48-CRE-1-G(E)5	1200*1200*810+440	48kW	220V, 50Hz, 130W	DN20	DN15/DN40
燃氣環保雙頭單尾炒爐	SZCT48/96-CRE-2-1G(E)5	1800*1200*810+440	96kW	220V, 50Hz, 130Wx2	DN40	DN15/DN40
燃氣環保雙頭雙尾炒爐	SZCT48/96-CRE-2-G(E)5	2100*1200*810+440	96kW	220V, 50Hz, 130Wx2	DN40	DN15/DN40

型號(E)表示帶電磁安全制

(E) Represent electromagnetic valve safety device

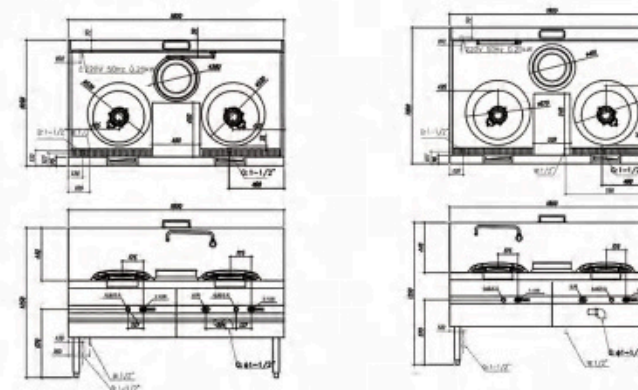

燃氣型中餐爐具系列 | Gas Chinese cooking range

產品特征
FEATURES

採用燃燒控制器分步控制電磁閥，火種未點燃時，主氣閥不會打開；
風機供風不正常，供氣不正常，意外熄火等故障，1秒鐘關閉燃氣，
壹鍵式風機、電子打火和離子熄火保護設計，
鼓風預混燃燒，噪音小於65分貝，燃燒充分，
壹氧化碳排放量小於0.01%；燃氣和空氣混合燃燒充分，火力猛勁，熱效率高。

Stepwise controlled by duplex solenoid valve, the main gas valve doesn't open until the fire ignites. As will be cut off in 1 second once the air or gas is supplying abnormally. One-button control blower, electronic pulse ignition and ion detector flame failure protection. Blast pre-mixing combustion with heavy power, combustion noise < 65dB, the emission of carbon monoxide < 0.01%.

燃氣什碎爐系列 Gas crushing furnace series



產品名稱 Product Name	燃氣環保單頭什碎爐 (電磁安全製)	燃氣環保雙頭什碎爐 (電磁安全製)
型號 Model	SZCT32-SRE-1-H(E)	SZCT32/64-SRE-2-H(E)
規格(mm) Specification	750*900*810+440	1500*900*810+440
熱負荷 Gas power	32kW	64kW
風機 Blower	220v/130w	220v/130w*2
進氣口 Gas inlet	DN20/DN25	DN40/DN40
進水口/排水口 Water inlet / outlet	DN15/DN40	DN15/DN40

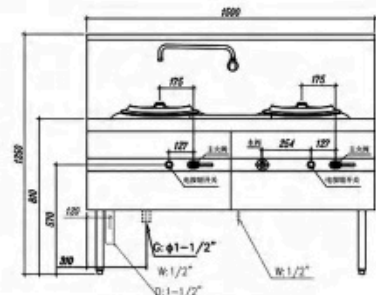
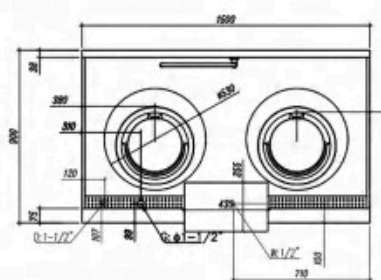
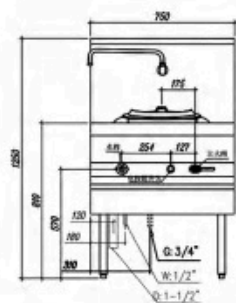
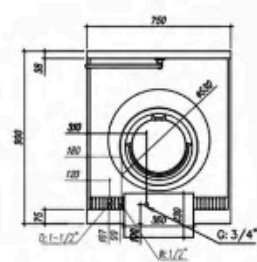

燃氣型中餐爐具系列 | Gas Chinese cooking range

產品特征
FEATURES

每個爐頭獨立配壓風機，使用行鏈風制實現風氣聯動開關，可調節供風大小，
臺面整體成型，方便清潔；
隔熱臺面，底部設計30mm厚的玻璃棉；
爐頭內冷的氣體吸收爐頭外殼熱量，降低爐頭溫度，提高爐頭的使用壽命
整體填磚，防止漏火攪壞填腔；
感應針使用溫度超過1200度，不易燒壞。

Each burner had equipped with blower. adopted chain wind system adjust the air and gas supply at the same time. One punched worktop with 30mm heating insulation material, convenient for clean. Pre-mixed burner, The cold air decrease external shell temperature of the burner, prolong service life. A monolithic brick, avoid damaging the chamber by the leaked fire. Thermocouple service temperature is over than 1200 degree, difficult to damaged

燃氣開放式炒爐系列 Gas open frying furnace series



產品名稱 Product Name	型號 Model	規格(mm) Specification	熱負荷 Gas power	風機 Blower	進氣口 Gas inlet	進水口/排水口 Water inlet / outlet
燃氣環保單頭單尾開放式炒爐	SZCT42-CRE-1-LF(E)	1200*1050*810+100	42kW	220V, 50Hz, 130W	DN20/DN25	DN15/DN40
燃氣環保雙頭單尾開放式炒爐	SZCT42/84-CRE-2-1LF(E)	1800*1050*810+100	84kW	220V, 50Hz, 130Wx2	DN40/DN50	DN15/DN40
燃氣環保雙頭雙尾開放式炒爐	SZCT42/84-CRE-2-LF(E)	2100*1050*810+100	84kW	220V, 50Hz, 130Wx2	DN40/DN40	DN15/DN40
燃氣環保開放式單頭上海式炒爐	SPT+ZCT42/47-CRE-1-PF(E)	1400*1050*810+100	47kW	220V, 50Hz, 130W	DN20/DN25	DN15/DN40
燃氣環保開放式雙頭上海式炒爐	SPT+ZCT42/94-CRE-2-PF(E)	2400*1050*810+100	94kW	220V, 50Hz, 130Wx2	DN40/DN40	DN15/DN40

型號(E)表示帶電磁安全制
(E) Represent electromagnetic valve safety device

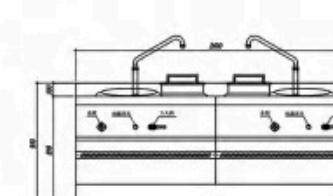
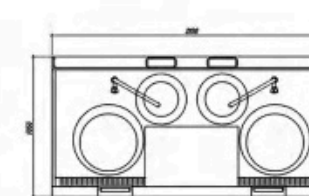
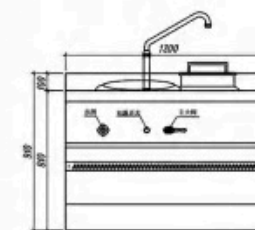
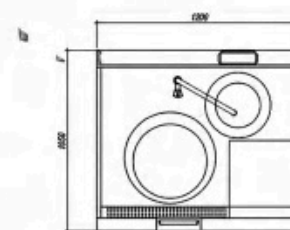

產品特征
FEATURES

採用燃燒控制器分步控制電磁閥，火種未點燃時，主氣閥不會打開。風機供風不正常，供氣不正常，意外熄火等故障，1秒鐘關閉燃氣，壹鍵式風機、電子打火和離子熄火保護設計，臺面整體成型，方便清潔；隔熱臺面，感應針使用溫度超過1200度，不易燒壞
鼓風預混燃燒，噪音小於65分貝，燃燒充分，火力猛勁，熱效率與壹般 滿風爐頭相比可節能30%以上，可調節供風大小
鼓風預混燃燒，噪音小於65分貝，燃燒充分，火力猛勁，熱效率與壹般 滿風爐頭相比可節能30%以上，可調節供風大小

Stepwise controlled by duplex solenoid valve, the main gas valve doesn't open until the fire ignites. As will be cut off in 1 second once the air or gas is supplying abnormally. One-button control blower, electronic pulse ignition and ion detector flame failure protection. One punched worktop with convenient for clean. Blast premixing combustion, heavy power, combustion noise < 65dB, energy saving more than 30% to compare with other blower burner. Each burner had equipped with blower. adopted chain wind system adjust the air and gas supply at the same time. Thermocouple service temperature is over than 1200 degree, difficult to damaged



燃氣大炒爐系列(4寸環保爐頭系列) Gas Frying Stove Series (4-inch Eco friendly Stove Head Series)

產品名稱 Product Name	型號 Model	規格(mm) Specification	熱負荷 Gas power	風機 Blower	進氣口 Gas inlet	進水口/排水口 Water inlet / outlet
燃氣環保單頭大炒爐	SDGT48-CRE-1-D(E)	1200*1050*810+440	48kW	220V, 50Hz, 130W	DN20	DN15/DN40
燃氣環保雙頭大炒爐	SDGT48/96-CRE-2-D(E)	2100*1050*810+440	96kW	220V, 50Hz, 130Wx2	DN40	DN15/DN40
燃氣環保單頭大炒爐	SDGT48-CRE-1-B(E)	1200*1200*810+440	48kW	220V, 50Hz, 130W	DN20	DN15/DN40
燃氣環保雙頭大炒爐	SDGT48/96-CRE-2-B(E)	2100*1200*810+440	96kW	220V, 50Hz, 130Wx2	DN40	DN15/DN40

燃氣大炒爐系列(5寸環保爐頭系列) Gas Frying Stove Series (5-inch Eco friendly Stove Head Series)

產品名稱 Product Name	型號 Model	規格(mm) Specification	熱負荷 Gas power	風機 Blower	進氣口 Gas inlet	進水口/排水口 Water inlet / outlet
燃氣環保單頭大炒爐	SDGT56-CRE-1-D(E)5	1200*1050*810+440	56kW	220V, 50Hz, 130W	DN20	DN15/DN40
燃氣環保雙頭大炒爐	SDGT56/112-CRE-2-D(E)5	2100*1050*810+440	112kW	220V, 50Hz, 130Wx2	DN40	DN15/DN40
燃氣環保單頭大炒爐	SDGT56-CRE-1-B(E)5	1200*1200*810+440	56kW	220V, 50Hz, 130W	DN20	DN15/DN40
燃氣環保雙頭大炒爐	SDGT56/112-CRE-2-B(E)5	2100*1200*810+440	112kW	220V, 50Hz, 130Wx2	DN40	DN15/DN40

產品特征
FEATURES

水膽採用1.5mm耐熱不銹鋼加工，4條S形火管結掩表面隔熱處理兩組獨立的燃氣燃燒控制系統，脈衝電子點火，離子熄火保護。
設置長明火種，超溫缺水保護防止幹燒
設置時間控制，可根據需要設定工作時間（0-60分鐘）
設置櫃內照明功能。
設置補水箱，全不銹鋼浮球自動補水
硬水地區使用該設備必須裝配軟化水設置

Water tank is made of 1.5mm heat-resisting stainless steel with 4pcs S-type fire tube. Two group independent control combustion system, over temperature and water lack protection, prevent dry heating. Set up stand pilot and electronic pulse ignition and ion detector flame failure protection. Set up time control, can be set 0-60 minutes according to requirement. Set up inner illumination. Set up automatic filling water box, completely SS floating ball to keep the water level balance. Required to install water softener device for hard water areas

燃氣推車萬用蒸櫃 Gas Roll-In Steam Cabinet



產品名稱 Product Name	型號 Model	規格(mm) Specification	熱負荷 Gas power	電源 Power supply	進氣口 Gas inlet	進水口/排水口 Water inlet / outlet	備註 Remarks
燃氣推車萬用蒸櫃	SZXT26/52-SBE-1DC	1250*900*1900	52kW	220V, 50Hz, 130W	DN20	DN15/DN40	可放18個2/1盤
燃氣推車萬用蒸櫃	SZXT26/52-SBE-1SE	1050*800*1900	52kW	220V, 50Hz, 130Wx2	DN20	DN15/DN40	可放18個1/1盤
燃氣雙門推車萬用蒸櫃	SZXT39/78-SBE-2DC	2150*900*1900	78kW	220V, 50Hz, 130Wx2	DN25	DN15/DN40	可放36個2/1盤

蒸用蒸櫃推車 (18*1/1GN) 配SBE-1SE-G 可放18個1/1GN盤

萬用蒸櫃推車 (18*2/1GN) 配SBE-1DC-G&SBE-2DC-G蒸櫃用 可放18個2/1GN盤

型號(E)表示帶電磁安全制
(E) Represent electromagnetic valve safety device

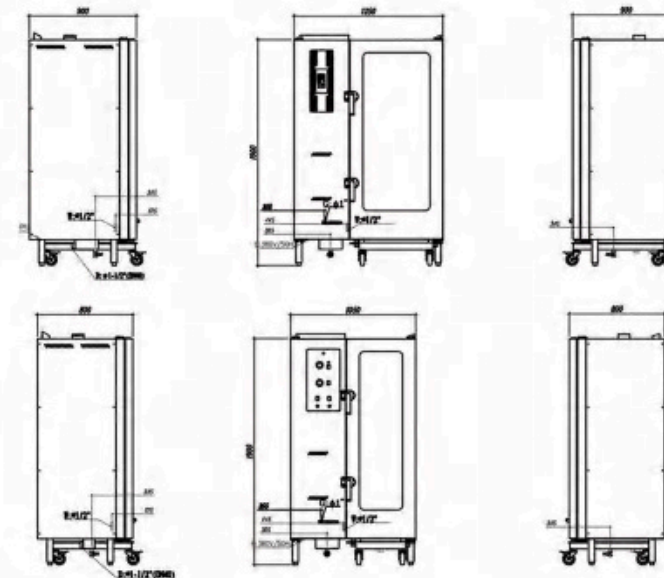

燃氣環保蒸櫃 Gas Environmental Steam Cabinet



產品特征 FEATURES

燃燒系統採用燃燒控制器分步控制雙聯電磁穩壓閥，火種未點燃時，主氣閥不打開，不會有大量燃氣泄出；設置穩壓調壓閥，燃燒火焰穩定；配置脈沖電子點火裝置；離子檢測熄火保護；有常明火種和與火管數相同的主火燃燒器，全部為自引風大氣式結構；主火燃燒器由兩個主火閥控制，可根據需要通過主火閥控制火力大小；每個蒸層獨立分開，無蒸汽串漏，蒸汽流動合理，上下加熱均勻，有效提高蒸汽利用率

Stepwise controlled by duplex solenoid valve, the main gas valve doesn't open until the fire ignites. set up pressure regulator, stand pilot and electronic pulse ignition and ion detector flame failure protection. Adopted Inject burner. two hand valve control one or two burner, kinds of heating power for options according to needs. every drawer cabinet equipped with independent switcher which improve the steam utilization

火管結構水膽，受熱面積大、熱效率高，熱效率大於85%，燃氣用量節約200%；爐頭燃燒完全，煙氣中CO含量\$0.05%；燃燒噪音小於65dB(A)；設置超溫缺水保護，防止幹燒損壞水膽；蒸櫃水膽使用不銹鋼加工，火管加熱結構內部設置“S”形火管，通過設置在補水箱內的浮閥自動控制入水

Fire tubes structure of the water tank, enlarges the heating appearance, thermal efficiency >85%, gas saving 20% the emission of carbon monoxide < 0.05%, combustion noise < 65dB. Set up over temperature and water lack protection. prevent dry heating. Water tank is made of heat-resisting stainless steel. "S-TYPE" fire tube structure. Set up automatic filling water box, completely SS floating ball to keep the water level balance

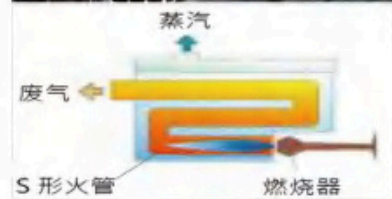

燃氣環保蒸櫃 Gas Environmental Steam Cabinet

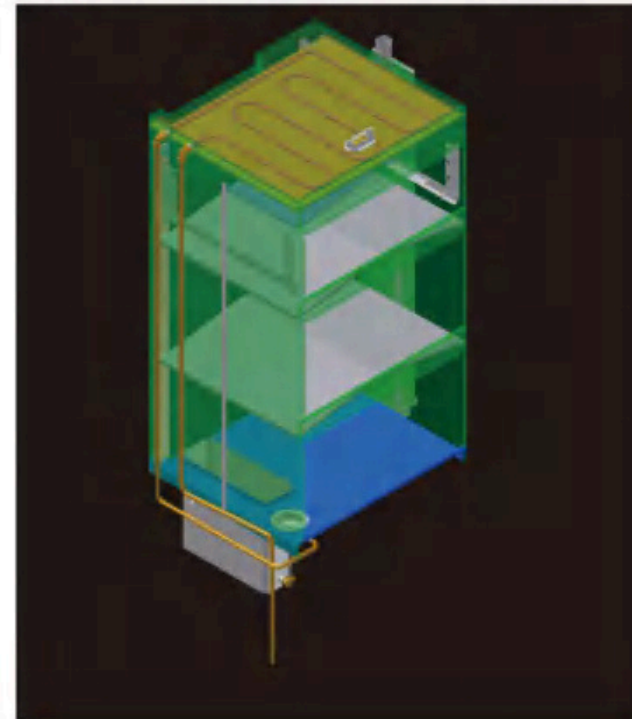

熱回收裝置 Heating recover device

(此功能為客戶選配)

頂部設計熱回收器，將排出蒸汽的熱置回收，可提高熱效率。

此功能只適用於單門蒸櫃、三門蒸櫃、五門蒸櫃

Designed heating recover device above the cabinet which recycle the output steam to improve the heat efficiency. This function fit with single door steam cabinet, triple door steam cabinet, 5-door steam cabinet.

產品名稱 Product Name	型號 Model	規格(mm) Specification	熱負荷 Gas power	電源 Power supply	進氣口 Gas inlet	進水口/排水口 Water inlet / outlet
燃氣環保單門蒸櫃	SZXT26/39-SCE-1(E)	800*900*1800	39kW	220V/50Hz/0.025kW	DN20/DN25	DN15/DN40
燃氣環保雙門蒸櫃	SZXT26/39-SCE-2(E)	900*900*1765	39kW	220V/50Hz/0.025kW	DN20/DN25	DN15/DN40
燃氣環保三門蒸櫃	SZXT26/39-SCE-3(E)	900*900*1900	39kW	220V/50Hz/0.025kW	DN20/DN25	DN15/DN40
燃氣環保三門蒸櫃	SZXT26/52-SCE-3X(E)	1200*900*1900	52kW	220V/50Hz/0.025kW	DN20/DN25	DN15/DN40
燃氣環保五門蒸櫃	SZXT26/39-SCE-5(E)	900*900*1970	39kW	220V/50Hz/0.025kW	DN20/DN25	DN15/DN40
燃氣環保雙門對開蒸櫃	SZXT26/52-SCE-2D(E)	1150*900*1800	52kW	220V/50Hz/0.025kW	DN20/DN25	DN15/DN40

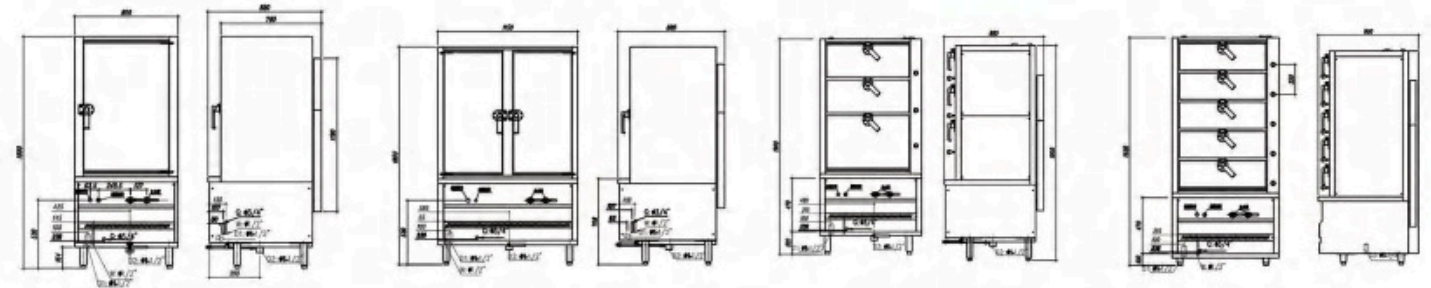

多层炊饭机 MULTIPLE DECK RICE COOKER



产品特征
FEATURES

智能化程度高

在高精度传感器和智能芯片的控製下，自動識別米量，精確調節火力確保最佳煮曲線
預約煮飯功能，進一步解放您的雙手
多種煮飯模式，獨有的暫停功能設計，為花色米飯提供了可能

Smart and Intelligent

Controlled with precise sensors and intelligent chips, it automatically recognizes the amount of rice and smartly adjusts the firepower to ensure the best cooking atmosphere.
Pre-setting of a cooking time makes hassle-free cooking.
Multiple cooking modes and unique <Pause> function enable various possibility of cooked rice results.

使用維護簡單

防水輕觸按鈕，三層獨立操作，使用更加靈活。可抽出式接渣盤設計，使清洗變得更加容易
自我診斷並顯示錯誤代碼，一旦出現故障或異常時，可以第一時間採取措施，最大降低風險

Simple to use, Easy to maintain

Waterproof touch panel which individually operates on three decks cooking. Flexible cooking. Withdrawable slag tray makes cleaning easier.
Self-diagnosis with error code display. When faulty occurs, measures can be taken immediately to minimize the breakdown time.

多重構造 有效隔熱

多重構造，有效的隔熱設計不僅使得系統更加穩定，而且使您的操作者更加安全，使用環境更加人性化

Multiple layer constructions with optimal insulation

Multiple layer constructions and optimal thermal insulation not only make the operation more stable, it also gives the operator a safer working environment.

多重安全保護

內置離子熄火保護、超溫保護、超時保護。更有雙重電磁閥封口防止燃氣意外泄露，全方位保護您的使用安全

Safety features

Built-in safety protection features such as: flame failure device, high temperature limit, overtime cooking. There is also a dual solenoid safety valve to prevent accidental gas leakage, which protects work safety in all aspects.

多层炊饭机 MULTIPLE DECK RICE COOKER

MLCM-G2

柜式炊饭机安装尺寸图

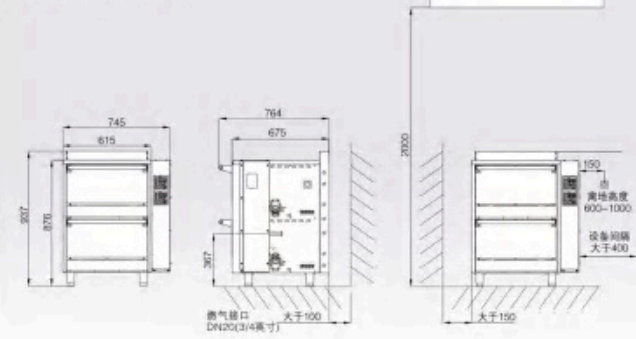

MLCM-G3

柜式炊饭机安装尺寸图

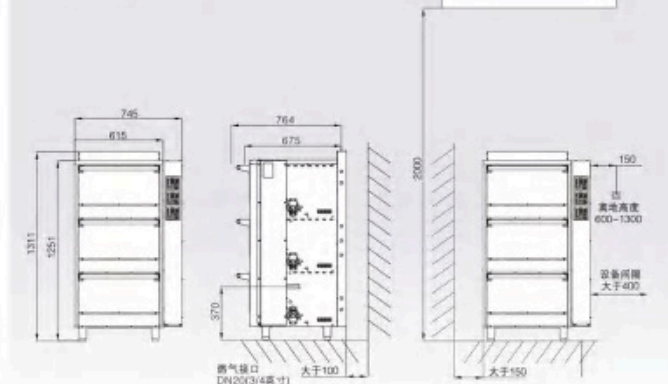

规格参数表 Product Specification table

产品名称 Product Name	双层炊饭机 2-Deck Rice Cooker	三层炊饭机 3-Deck Rice Cooker
型号 Model	MLCM-G2	MLCM-G3
外形尺寸 (mm) Dimensions (mm):	745*764*937	745*764*1311
生产能力 (kg) Production Capacity (kg):	14	21
电功率 (W) Electric Power Loading (W):	32	45
热负荷 (kW) Gas Loading (kW):	18	27
耗气量 Gas Consumption (Kg/serve):	液化气0.3kg左右/锅, 天然气0.4左右/锅 LPG: 0.3kg/serve; NG: 0.4kg/serve	
重量 (kg) Weight (Kg):	100	150
标准配件 Standard Accessories:	锅2个, 锅盖2个 2*pot with cover lid	锅3个, 锅盖3个 3*pot with cover lid
电源 Voltage:	220V/1NPE/50Hz - 13A	
燃气接口 Gas pipe inlet:	DN20	
安全装置 Safety Device:	离子熄火保护、超温保护、超时保护 Dual safety solenoid valve, High Temperature Limit, Overtime Cooking Protection.	

產品特征
FEATURES

兩個主火閥門控制多個爐頭，可選擇不同蒸汽出量，有快蒸、慢蒸和保溫三種功效；
配置 電磁安全制，意外熄火等故障，1秒鐘關閉燃氣；
電子點火，壹鍵式操作，燃燒無需風機鼓風；
設置蒸汽開關和蒸汽安全排放口，使用安全方便。

Two hand valve control one or two burner, kinds of heating power for options according to needs (fast steam, slow steam, keep warm). Equipped with duplex solenoid valve device and steam emission hole. As will be cut off in 1 second once the air or gas supply abnormally. Electronic ignition, one button operation, without blower. Every drawer cabinet equipped with independent switcher.



產品特征
FEATURES

火管結構水膽，受熱面積大、熱效率高，熱效率大於85%，燃氣用量節約20%；
爐頭燃燒完全，煙氣中CO含量≤0.05%；
燃燒噪音小於65dB(A)；設置超溫缺水保護，防止燒壞水膽
蒸櫃水膽使用不銹鋼加工，火管加熱結構內部設置“S”形火管，通過設置在補水箱內的浮閥自動控制入水

Fire tubes structure of the water tank, enlarges the heating appearance, thermal efficiency >85%, gas saving 20%, the emission of carbon monoxide <0.05%, combustion noise <65dB. Set up over temperature and water lack protection, prevent dry heating. Water tank is made of heat-resisting stainless steel. "S-TYPE" fire tube structure. Set up automatic filling water box, completely SS floating ball to keep the water level balance

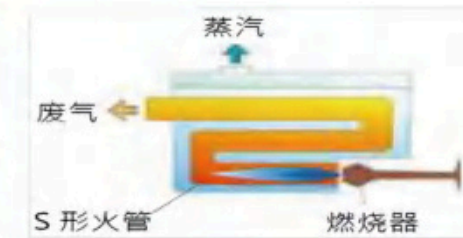
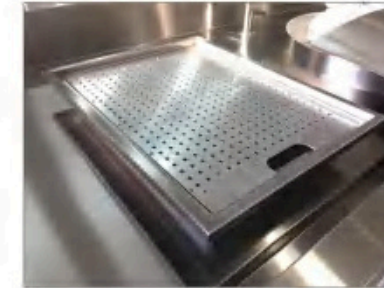

燃氣環保蒸爐系列 (1050系列) Gas Environmental Protection Steam Stove Series (1050 Series)

產品名稱 Product Name	型號 Model	規格(mm) Specification	熱負荷 Gas power	電源 Power supply	進氣口 Gas inlet	進水口/排水口 Water inlet / outlet
燃氣環保單頭蒸爐	SCZT26/39-CSE-1S (E)	900*1050*810+440	39kW	220V/50Hz/0.025kW	DN20/DN25	DN15/DN40
燃氣環保雙頭蒸爐	SCZT26/52-CSE-2S (E)	1500*1050*810+440	52kW	220V/50Hz/0.025kW	DN20/DN25	DN15/DN40
燃氣環保雙頭腸粉爐	SCZT26/39-RSE-2S (E)	1200*1050*810+440	39kW	220V/50Hz/0.025kW	DN20/DN25	DN15/DN40
燃氣環保單頭蒸爐連單頭腸粉爐	SCZT26/52-RSE-2 (E)	1500*1050*810+440	52kW	220V/50Hz/0.025kW	DN20/DN25	DN15/DN40

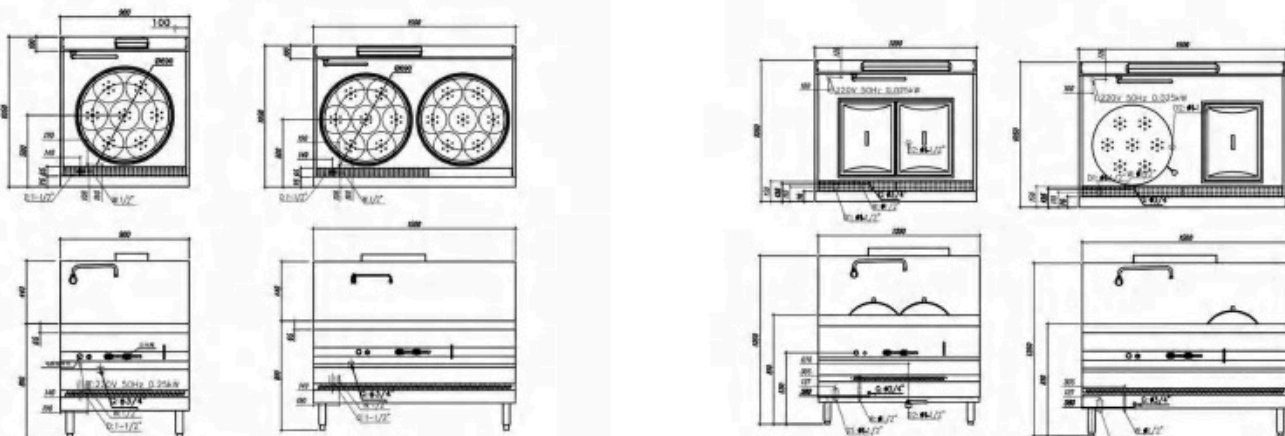

燃氣環保蒸爐系列 (1200系列) Gas Environmental Protection Steam Stove Series (1200 Series)

產品名稱 Product Name	型號 Model	規格(mm) Specification	熱負荷 Gas power	電源 Power supply	進氣口 Gas inlet	進水口/排水口 Water inlet / outlet
燃氣環保單頭蒸爐	SCZT26/39-XSE-1S (E)	900*1200*810+440	39kW	220V/50Hz/0.025kW	DN20/DN25	DN15/DN40
燃氣環保雙頭蒸爐	SCZT26/52-XSE-2S (E)	1500*1200*810+440	52kW	220V/50Hz/0.025kW	DN20/DN25	DN15/DN40
燃氣環保雙頭腸粉爐	SCZT26/39-HSE-2S (E)	1200*1200*810+440	39kW	220V/50Hz/0.025kW	DN20/DN25	DN15/DN40
燃氣環保單頭蒸爐連單頭腸粉爐	SCZT26/52-HSE-2 (E)	1500*1200*810+440	52kW	220V/50Hz/0.025kW	DN20/DN25	DN15/DN40

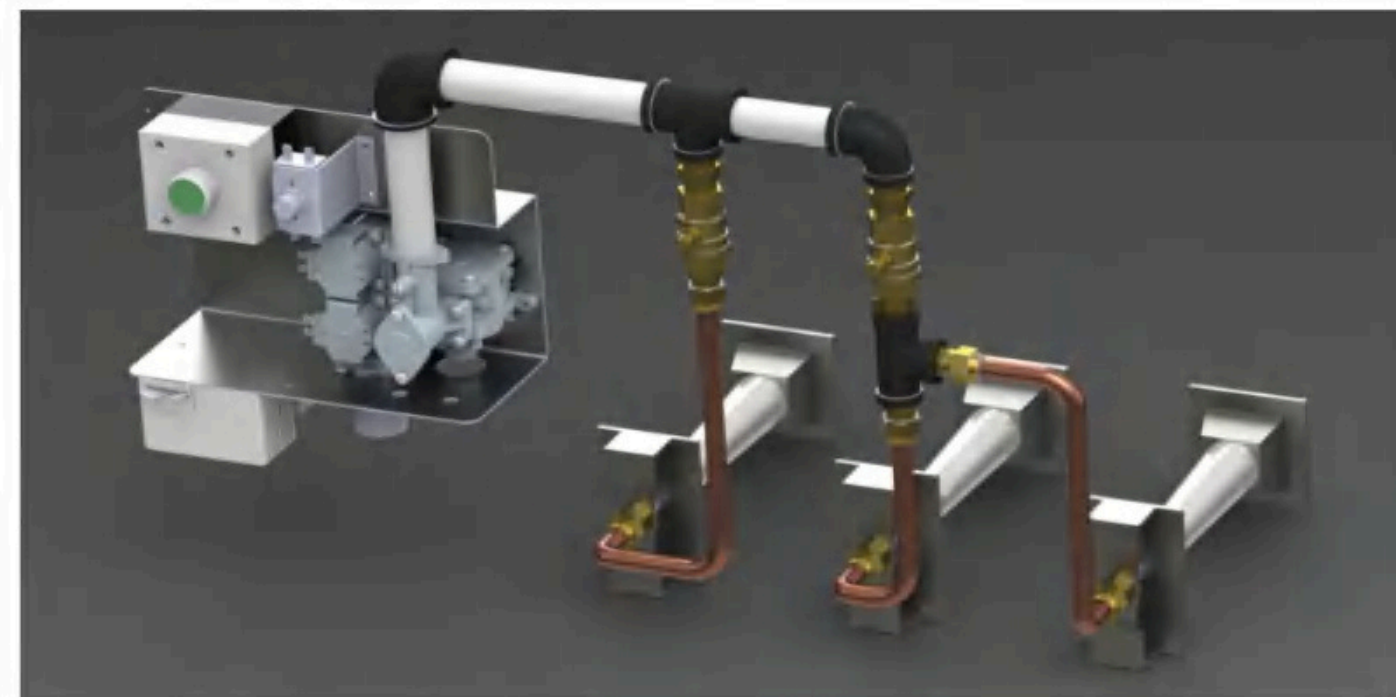

產品特征
FEATURES

11寸強力爐頭，熱負荷16kW；
外殼採用模具壓制而成，爐身各部分結合緊密，能有效防止熱氣散失；外殼有上、中、下三部分組成，運輸拆裝方便；
耐熱不銹鋼反射板設計，經久耐用，節約能源，烘烤均勻；
配置安全制，防止燃氣洩漏事故；獨立常明火種設置，安全可靠；
設置與安全制聯動的自動脈衝電子點火，操作方便。
雙層外殼，外部溫度低於85°C防止燒傷

11"enhance burner, power loading:16kw
Completely SS body with better seal.
This equipment consist of top part , mid part and base part. convenient for install and transport.
Equipped with heat reflecting board ,durable , energy saving , even heating .
Equipped with duplex solenoid valve device and electronic pulse ignition ,easy operation .
Double jacket body , external shell temperature is less than 85°C.

產品特征
FEATURES

雙層隔熱外身，耐熱不銹鋼反射板設計，經久耐用，節約能源，烘烤均勻；
配置安全制，防止燃氣洩漏事故；
獨立常明火種設置，熱電偶熄火保護裝置，安全可靠；
設置與安全制聯動的自動脈衝電子點火，操作方便；
頂部設置可旋轉掛架。

Double jacket body . equipped with heat reflecting board ,durable , energy saving , even heating.
Equipped with duplex solenoid valve device , thermocouple protection to prevent gas leakage.
Electronic pulse ignition , easy operation.
Equipped with rotate hooks on the top of equipment.

燃氣雙層燒鴨爐系列 Gas Double Layer Duck Roaster series



產品名稱 Product Name	燃氣 φ32"雙層燒鴨爐 (安全掣)帶溫度表	燃氣 φ36"雙層燒鴨爐 (安全掣)帶溫度表
型號 Model	SKXT16-CDRE-8D	SKXT16-CDRE-9D
規格(mm) Specification	Φ840*1530	Φ940*1530
熱負荷Gas power	16kW	16kW
進氣口Gas inlet	DN20	DN20
標配 Standard	燒烤石	燒烤石

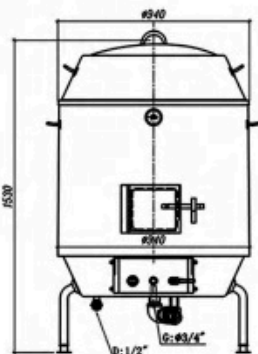
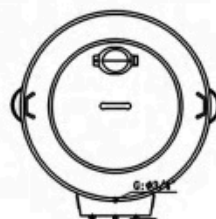
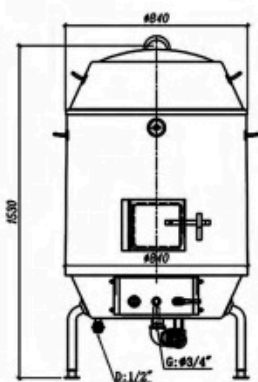
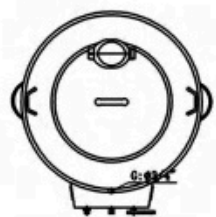

燃氣燒鴨、燒豬爐 (太空式) Gas Duck/Pig Roaster (Full-Height Type)



產品名稱 Product Name	燃氣燒鴨爐連安全掣(太空式)	燃氣燒豬連安全掣(太空式)
型號 Model	SKXT16-CPRE-10S	SKXT28-CPRE-11S
規格(mm) Specification	Φ1000*1680	Φ1100*1925
熱負荷Gas power	16kW	28kW
進氣口Gas inlet	DN20	DN20
標配 Standard	燒烤石	燒烤石



耐熱不銹鋼反射板可輕易拆出清洗
removable heat reflecting board with convenient clean

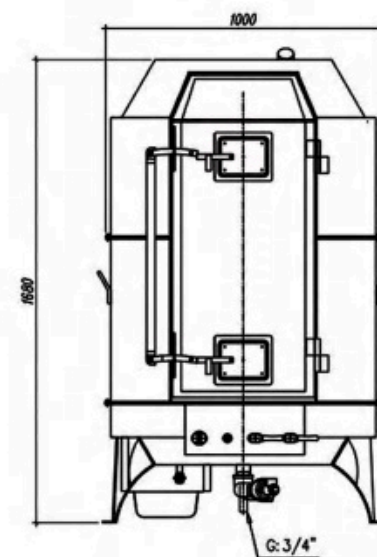

產品特征
FEATURES

雙層隔熱外身，背部和爐門設置雙層弧面鋼化玻璃視窗，背部可視角120。自動旋轉掛架，配置10個掛鉤；設置溫度、時間控制，帶數字顯示
 燒鴨爐：可放置8-10只燒鴨 燒豬爐：可放置3-4只燒豬
 電熱型：採用優質發熱管加熱
 燃氣型：耐熱不銹鋼反射板設計，經久耐用，節約能源，烘烤均勻；使用燃燒控制器，設置長明火種，脈衝電子點火，離子熄火保護。

Designed double heating insulation SS jacket body and double curved tempered glass in front and back of the roaster; 120° viewing angle. 10 PCS automatic rotate hooks. Equipped with temperature setting and time setting function with digital display.
 Duck roaster: placed 8-10 PCS ducks. Pig roaster: placed 3-4 PCS pigs
 Heating type: Gas and electric
 Gas type: Equipped with heat reflecting board, durable, energy saving, even heating.
 Equipped with duplex solenoid valve device and electronic pulse ignition, easy operation

可視燒豬、燒鴨爐系列 Visual Roast Pig and Roast Duck Stove Series



產品名稱 Product Name	燃氣可視燒豬燒鴨爐 (電磁安全製)
型號 Model	CS-TDR11-G
規格(mm) Specification	Φ1100*1900
熱負荷Gas power	16kW
進氣口Gas inlet	DN20
電壓 Voltage	220V/50Hz
功率 power	0.0025kW

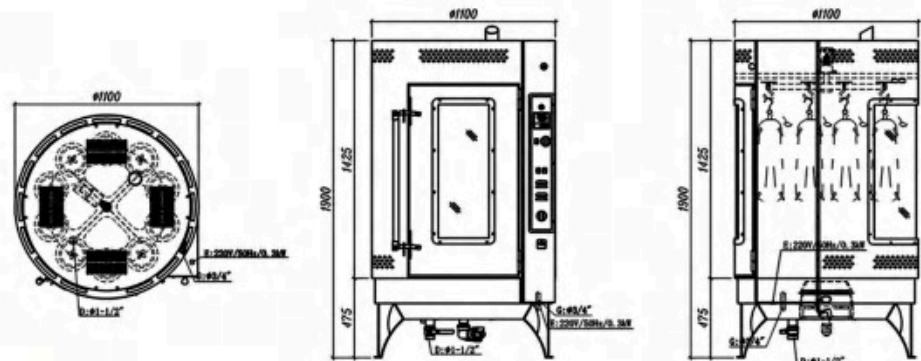

產品特征
FEATURES

設置與安全製聯動的自動脈衝電子點火
 3只條形爐頭，獨立控制
 意大利進口等徑球閥
 耐熱不銹鋼反射板設計，經久耐用
 節約能源，烘烤均勻
 獨立長明火種設置，安全可靠 底部設置盛油盆

Set automatic pulse electronic point linked with safety system
 3 PCS strip burner with independent control.
 Equal diameter ball valve imported from Italy
 Equipped with heat reflecting board, durable, energy saving, even heating
 Designed grease tray in the bottom and stand pilot fire.

燃氣燒豬爐 Gas Pig Roaster



產品名稱 Product Name	燃氣燒豬爐 (安全製)
型號 Model	SSKT50-CPRE-3S
規格(mm) Specification	620*1200*600
熱負荷Gas power	50kW
進氣口Gas inlet	DN20



耐熱不銹鋼反射板可輕易拆出清洗
 Heat resistant stainless steel reflector Easy to remove and clean

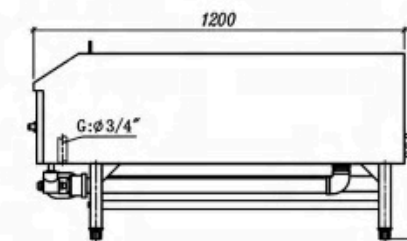
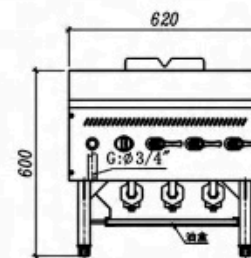
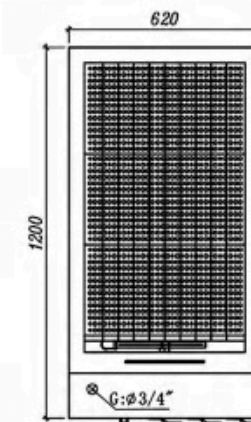

燃氣型中餐爐具系列 | Gas Chinese cooking range

產品特征
FEATURES

燃氣矮湯爐採用8寸或14寸強力爐頭，操作方便，火力集中
 燃燒噪音小，環保節能，安全可靠
 加熱速度快，能保持食物的原色原味，保證食物營養不受破壞
 內置高效能熱電偶熄火安全裝置，確保設備安全運行
 脈衝電子點火

8" or 14" reinforce burner for options, easily operation, concentrated firepower
 Low combustion noise, environmental and saving, safety and reliable
 Quickly heating up to keep the food nutrition
 Equipped with thermocouple flame failure protection, ensure safety working of equipment
 Electronic pulse ignition
 Cast iron grid, equipped with grease collection tray in the bottom

燃氣型中餐爐具系列 | Gas Chinese cooking range

產品特征
FEATURES

3寸溝風爐頭，熱負荷：32kW；
 使用燃燒控制器，設置常明火種，脈衝電子點火，離子熄火保護；
 每壹個爐頭配置壹臺靜音風機（200V 50Hz 130W）

3" blower burner, gas loading 32kw.
 Equipped with combustion controller and electronic pulse ignition. Set up stand pilot and flame failure protection.
 Each burner equipped with one blower(220V 50Hz 100W)

燃氣矮湯爐系列 Gas Stock Pot Stove series



產品名稱 Product Name	型號 Model	規格(mm) Specification	熱負荷 Gas power	進氣口 Gas inlet	備註 Remarks
燃氣單頭單圈矮湯爐	SPTT14-SS-1-8S	550*650*500+200	14kW	DN25	8"強力爐頭
燃氣雙頭單圈矮湯爐	SPTT14/28-SS-2-8S	1100*650*500+200	28kW	DN25	8"強力爐頭
燃氣單頭單圈矮湯爐	SPTT14-SS-1-8F	550*650*500+750	14kW	DN25	8"強力爐頭
燃氣雙頭單圈矮湯爐	SPTT14/28-SS-2-8F	1100*650*500+750	28kW	DN25	8"強力爐頭
燃氣直式雙頭單圈矮湯爐	SPTT 14/28-SS-2V	550*1100*500+200	28kW	DN25	8"強力爐頭
燃氣單頭雙圈矮湯爐	SPTT28-SS-1-14D	600*760*500+200	28kW	DN25	14"強力爐頭
燃氣雙頭雙圈矮湯爐	SPTT28/56-SS-2-14D	1200*760*500+200	56kW	DN25	14"強力爐頭
燃氣單頭雙圈矮湯爐	SPTT28-SS-1-14F	600*760*500+750	28kW	DN25	14"強力爐頭
燃氣雙頭雙圈矮湯爐	SPTT28/56-SS-2-14F	1200*760*500+750	56kW	DN25	14"強力爐頭
燃氣直式雙頭雙圈矮湯爐	SPTT28/56-SS-2D	600*1300*500+200	56kW	DN25	14"強力爐頭

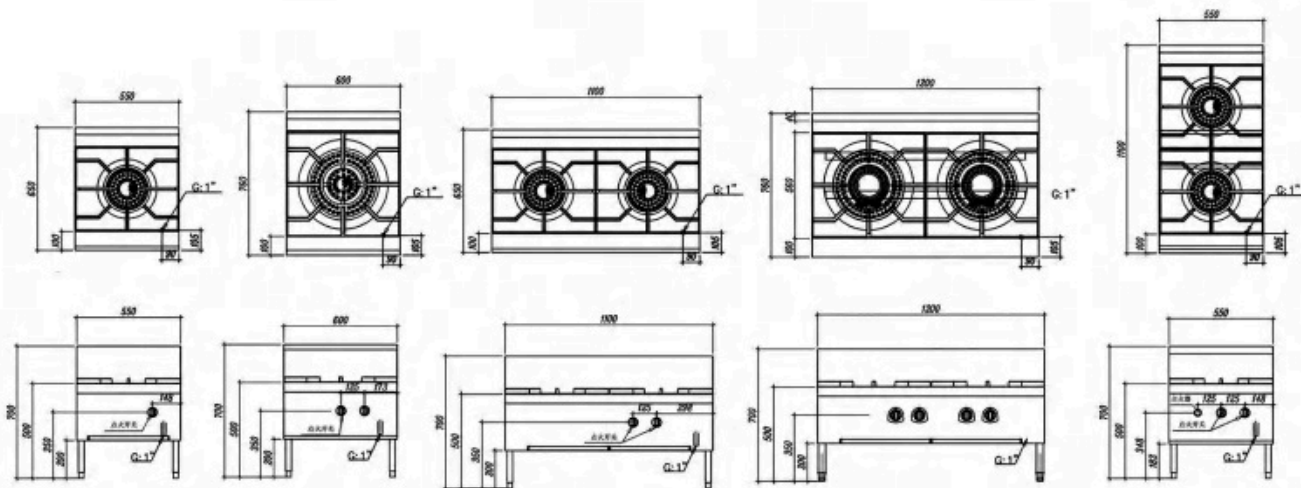

燃氣矮湯爐(環保爐頭系列) Gas Short Soup Stove (Environmental Protection Stove Series)



產品名稱 Product Name	燃氣單頭矮湯爐	燃氣雙頭矮湯爐
型號 Model	SPTT32-PSE-1-F (E)	SPTT32/64-PSE-2-F (E)
規格(mm) Specification	650*760*600+200	1200*760*600+200
熱負荷 Gas power	32kW	32kW*2
進氣口 Gas inlet	DN40	DN40
風機 Fan	220V,50Hz,48W	220V,50Hz,48W*2

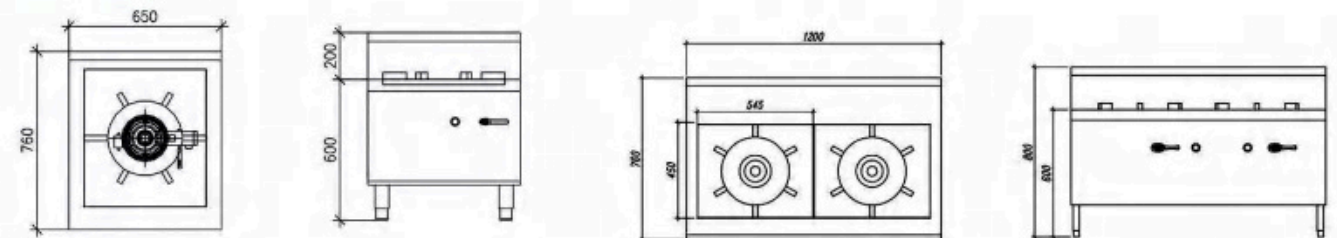

產品特征
FEATURES

操作方便，火力集中，加熱速度快
燃氣噪音小，環保節能，安全可靠
爐火開關連安全制內置高性能熄火安全裝置，確保工作環境安全可靠
鑄鐵爐花，底部設有盛油盆

Higher heating efficiency, easy operation and low combustion noise.
Electronic pulse ignition, environment and safety.
Set up flame failure protection, ensure reliable running.
Cast iron grid, set up grease drawer tray.

燃氣平頭爐系列 Gas Open Flame Range series



產品名稱 Product Name	型號 Model	規格(mm) Specification	熱負荷 Gas power	進氣口 Gas inlet	爐頭 Furnace head
燃氣四頭單圈平頭爐	SPTT5/20-FR-4S	800*760*810+150	20kW	DN25	6"文華爐頭
燃氣四頭單圈平頭爐	SPTT5/20-FR-4S(D)	800*1050*810+440	20kW	DN25	6"文華爐頭
燃氣四頭單圈平頭爐	SPTT5/20-FR-4S(B)	800*1200*810+440	20kW	DN25	6"文華爐頭
燃氣六頭單圈平頭爐	SPTT5/30-FR-6S	900*760*810+150	30kW	DN25	6"文華爐頭
燃氣六頭單圈平頭爐	SPTT5/30-FR-6S(D)	900*1050*810+440	30kW	DN25	6"文華爐頭
燃氣六頭單圈平頭爐	SPTT5/30-FR-6S(B)	900*1200*810+440	30kW	DN25	6"文華爐頭
燃氣四頭雙圈平頭爐	SPTT8/32-FR-4D	800*900*810+150	32kW	DN25	7"文華爐頭
燃氣四頭雙圈平頭爐	SPTT8/32-FR-4D(D)	800*1050*810+440	32kW	DN25	7"文華爐頭
燃氣四頭雙圈平頭爐	SPTT8/32-FR-4D(B)	800*1200*810+440	32kW	DN25	7"文華爐頭
燃氣六頭雙圈平頭爐	SPTT8/48-FR-6D	1200*900*810+150	48kW	DN25	7"文華爐頭
燃氣六頭雙圈平頭爐	SPTT8/48-FR-6D(D)	1200*1050*810+440	48kW	DN25	7"文華爐頭
燃氣六頭雙圈平頭爐	SPTT8/48-FR-6D(B)	1200*1200*810+440	48kW	DN25	7"文華爐頭

階梯型平頭爐為定製產品，可根據客戶需求選擇爐頭個數
The ladder type flat head furnace is a customized product, and the number of furnace heads can be selected according to the needs of customers

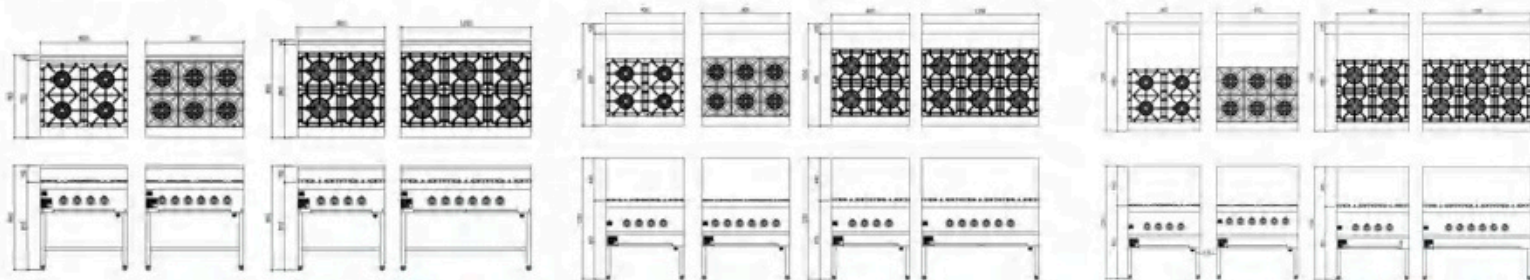

電熱型中餐爐具系列

ELECTRIC CHINESE COOKING RANGE



獨特的風格藝術 專業的烹飪技術

電熱蒸櫃系列產品，全不銹鋼機身結構
水膽採用1.5mm耐熱不銹鋼加工
內膽有保溫材料包裹，提高保溫性能
設計低水位及超溫保護功能
特別結構的矽膠門膠邊，蒸層排水U型管結構 櫃門不漏蒸汽
自動進水，防止電熱管幹燒
表面隔熱處理，浮球開關自動補水
設置時間控制，可根據需要設定工作時間0~60分鐘
可通過溫度設置保溫功能（85°C）壹櫃多用
設置櫃內照明功能
設置專門設計的排水盒子集中蒸層排水和水膽排水，並防止水膽水倒流入櫃內和防止櫃內蒸汽由下部外溢

UNIQUENESS PRODUCT TYPE AND PROFESSIONAL COOKING EQUIPMENT

Completely SS structure, Water tank is made of 1.5mm heat-resisting stainless steel with thermal insulation material cover for warming. Automatic filling water, over temperature and water lack protection, prevent dry heating.
Set up time control, can be set heating time (0-60 minutes) according to requirement.
Multi function for options—Full heating, slow heating, keep warm (Set up 85°C).
Set up inner illumination.
Special designed sealing silicone ring ensures the steam doesn't leak, each drawer cabinet set up U-type drainage slot to prevent the water over flowing.
Required to install water softener device for hard water areas



產品特征
FEATURES

水膽採用1.5mm耐熱不銹鋼加工 表面隔熱處理, 浮球開關自動補水; 設置超溫缺水保護, 防止幹燒; 設置時間控制, 可根據需要設定工作時間0~60分鐘; 可通過溫度設置保溫功能 (85°C) 壹櫃多用; 設置櫃內照明功能; 設置專門設計的排水盒子集中蒸層排水和水膽排水, 並防止水膽水倒流入櫃內和防止櫃內蒸汽由下部外溢; 每臺爐配壹輛18層推車; 硬水地區使用該設備必須裝配軟化水設置

Completely SS structure. Water tank is made of 1.5mm heat-resisting stainless steel with thermal insulation material cover for warming . Automatic filling water, over temperature and water lack protection , prevent dry heating. Special designed sealing silicone ring ensures the steam doesn't leak. each drawer cabinet set up U-type drainage slot prevent the water over flowing. Required to install water softener device for hard water areas

產品特征
FEATURES

水膽採用1.5mm耐熱不銹鋼加工 表面隔熱處理, 浮球開關自動補水; 設置超溫缺水保護, 防止幹燒; 設置時間控制, 可根據需要設定工作時間0~60分鐘; 可通過溫度設置保溫功能 (85°C) 壹櫃多用; 設置櫃內照明功能; 設置專門設計的排水盒子集中蒸層排水和水膽排水, 並防止水膽水倒流入櫃內和防止櫃內蒸汽由下部外溢; 每臺爐配壹輛18層推車; 硬水地區使用該設備必須裝配軟化水設置

Completely SS structure. Water tank is made of 1.5mm heat-resisting stainless steel with thermal insulation material cover for warming . Automatic filling water, over temperature and water lack protection , prevent dry heating. Set up time control, can be set heating time (0-60 minutes) according to requirement. Multi function for options----Full heating, slow heating, keep warm (Set up 85°C). Set up inner illumination. Equipped with 18 layer trolley for each steam cabinet. Special designed drainage system can prevent condensate water over flowing. Required to install water softener device for hard water areas

電熱車載蒸櫃 (電子版控制) Electric roll-in steam cabinet(Electronic control)



型號 Model	SBE-1DC-E
規格(mm) Specification (mm)	1050x900x1900
額定電壓 Rated voltage	380V/50Hz
額定功率 Rated power	39kW
進水/排水 Water inlet / drainage	DN15/DN40
備註 Remarks	可放18個2/1盤

電熱雙門車載蒸櫃 (電子版控制) Electric double door roll-in steam cabinet(Electronic control)



型號 Model	SBE-2DC-E
規格(mm) Specification (mm)	2150*900*1900
額定電壓 Rated voltage	380V/50Hz
額定功率 Rated power	57kW
進水/排水 Water inlet / drainage	DN15/DN40
備註 Remarks	可放36個2/1盤

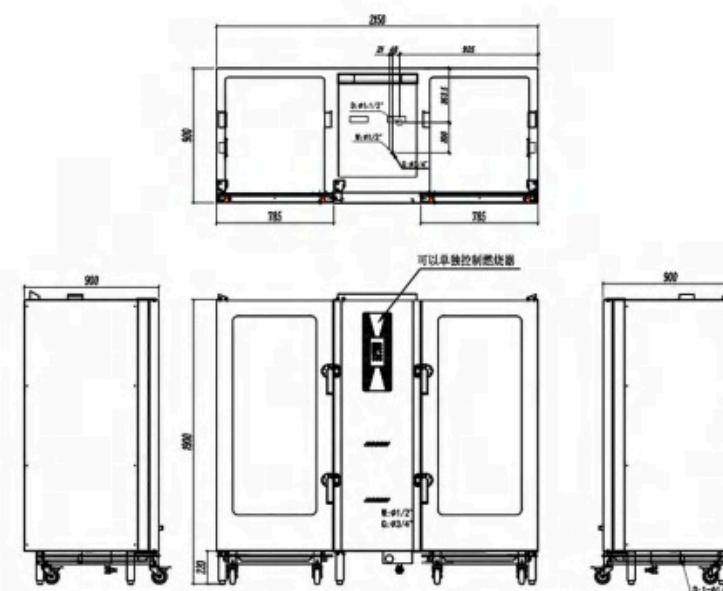

產品特征
FEATURES

電熱蒸櫃系列產品，全不銹鋼機身結構
水膽採用1.5mm耐熱不銹鋼加工
內膽有保溫材料包裹，提高保溫性能
設計低水位及超溫保護功能
特別結構的矽膠門膠邊，櫃門不漏蒸汽
自動進水，防止電熱管幹燒
蒸層排水U型管結構，防止蒸汽由下部外溢
硬水地區使用該設備必須裝配軟化水裝置

Completely SS structure, Water tank is made of 1.5mm heat-resisting stainless steel with thermal insulation material cover for warming. Automatic filling water, over temperature and water lack protection, prevent dry heating. Special designed sealing silicone ring ensures the steam doesn't leak. each drawer cabinet set up U-type drainage slot to prevent the water over flowing. Required to install water softener device for hard water areas

產品特征
FEATURES

電熱蒸櫃系列產品，全不銹鋼機身結構
水膽採用1.5mm耐熱不銹鋼加工
內膽有保溫材料包裹，提高保溫性能
設計低水位及超溫保護功能
特別結構的矽膠門膠邊，櫃門不漏蒸汽
自動進水，防止電熱管幹燒
蒸層排水U型管結構，防止蒸汽由下部外溢
硬水地區使用該設備必須裝配軟化水裝置

Completely SS structure, Water tank is made of 1.5mm heat-resisting stainless steel with thermal insulation material cover for warming. Automatic filling water, over temperature and water lack protection, prevent dry heating. Special designed sealing silicone ring ensures the steam doesn't leak. each drawer cabinet set up U-type drainage slot to prevents the water over flowing. Required to install water softener device for hard water areas

電熱單門蒸櫃 Electric Single Door Environmental Steam Cabinet



型號 Model	CS-1PH
規格(mm) Specification (mm)	800x900x1800
額定電壓 Rated voltage	380V
額定功率 Rated power	27kW
進水/排水 Water inlet / drainage	DN15/DN40
備註 Remarks	

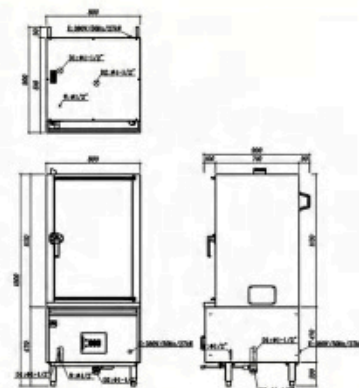

電熱單頭蒸爐 Electric single unit environmental steamer



型號 Model	CS-27P
規格(mm) Specification (mm)	750x900x810+440
額定電壓 Rated voltage	380V
額定功率 Rated power	27kW
進水/排水 Water inlet / drainage	DN15/DN40
備註 Remarks	配蒸板 水龍頭

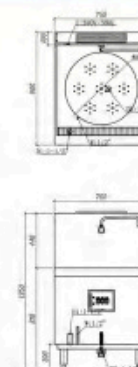

電熱雙頭蒸爐 Electric double unit environmental steamer



型號 Model	CS-45P
規格(mm) Specification (mm)	1500x900x810+440
額定電壓 Rated voltage	380V
額定功率 Rated power	54kW
進水/排水 Water inlet / drainage	DN15/DN40
備註 Remarks	配蒸板 水龍頭

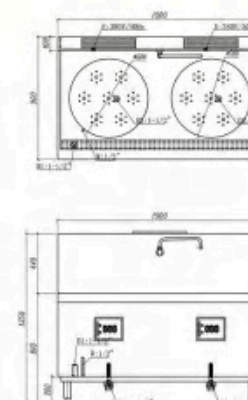

電熱雙頭腸粉爐 Electric double grid rice roll environmental steamer



型號 Model	CS-27H
規格(mm) Specification (mm)	1200x900x810+440
額定電壓 Rated voltage	380V
額定功率 Rated power	27kW
進水/排水 Water inlet / drainage	DN15/DN40
備註 Remarks	配腸粉蓋 水龍頭

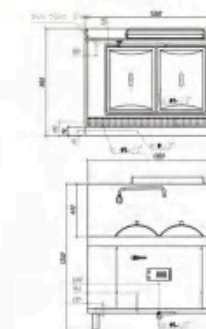

電熱三門蒸櫃 Electric Triple Door Environmental Steam Cabinet



型號 Model	CS-3PH	CS-3PX
規格(mm) Specification (mm)	900x900x1900	1200*900*1900
額定電壓 Rated voltage	380V	380V
額定功率 Rated power	36kW	45kW
進水/排水 Water inlet / drainage	DN15/DN40	DN15/DN40
備註 Remarks		

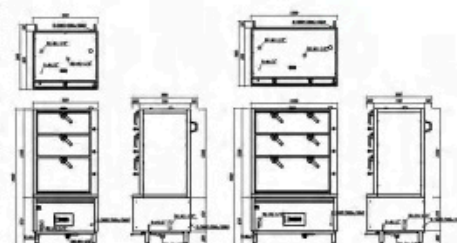

電熱雙門對開蒸櫃 Electric WING door environmental steam cabinet



型號 Model	CS-2CP
規格(mm) Specification (mm)	1150x810x1800
額定電壓 Rated voltage	380V
額定功率 Rated power	45kW
進水/排水 Water inlet / drainage	DN15/DN40
備註 Remarks	

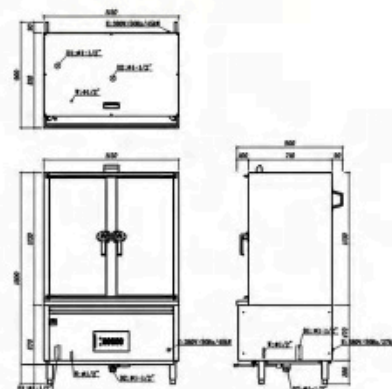

中式電磁炒爐系列 | Chinese Induction Wok Range

產品特征
FEATURES

整體臺面沖壓成型。
電磁爐無明火、無廢氣，可減少環境汙染。
電磁感應加熱，熱效率高達90%以上
微電腦溫控系統，具有無鍋檢測。
設置超溫，自動故障檢測，電壓過高過低及缺相保護等
火力電子顯示，多檔火力調節，功率漸進式可調
雙重金屬炒鍋遮罩設計，防止電磁輻射
進口凹面玻璃，與弧面達到完美結合。

One punched work top,
No open flame, no flue gas emission, reduces environmental
polluting
Electromagnetic heating, microcomputer temperature control
system, thermal efficiency is over 90%
Equipped with no pot detection, over temperature protection,
automatic fault detection, voltage abnormally and open phase
protection.
Adjustable gradual model heating type with digital display.
Double-layered SS shell can prevent electromagnetic radiation.
Imported concave glass, perfectly combines with worktop.

大功率電磁爐系列 High power induction cooker series



產品名稱 Product Name	型號 Model	規格(mm) Specification	熱負荷 Gas power	電壓 Voltage	標配 Standard	選配 Optional
中式電磁單頭單尾炒爐	MLWC-1N-E	1200*1050*810	15kW	380V/50Hz	調料板 鍋枕 炒鍋	凍水盆 爪籬架
中式電磁雙頭單尾炒爐	MLWC-2-1N-E	1800*1050*810	15kW*2	380V/50Hz	調料板 鍋枕 炒鍋	凍水盆 爪籬架
中式電磁雙頭雙尾炒爐	MLWC-2N-E	2100*1050*810	15kW*2	380V/50Hz	調料板 鍋枕 炒鍋	凍水盆 爪籬架
中式電磁單頭單尾炒爐	MLWC-1-E	1200*1200*810	15kW	380V/50Hz	調料板 鍋枕 炒鍋	凍水盆 爪籬架
中式電磁雙頭單尾炒爐	MLWC-2-1-E	1800*1200*810	15kW*2	380V/50Hz	調料板 鍋枕 炒鍋	凍水盆 爪籬架
中式電磁雙頭雙尾炒爐	MLWC-2-E	2100*1200*810	15kW*2	380V/50Hz	調料板 鍋枕 炒鍋	凍水盆 爪籬架

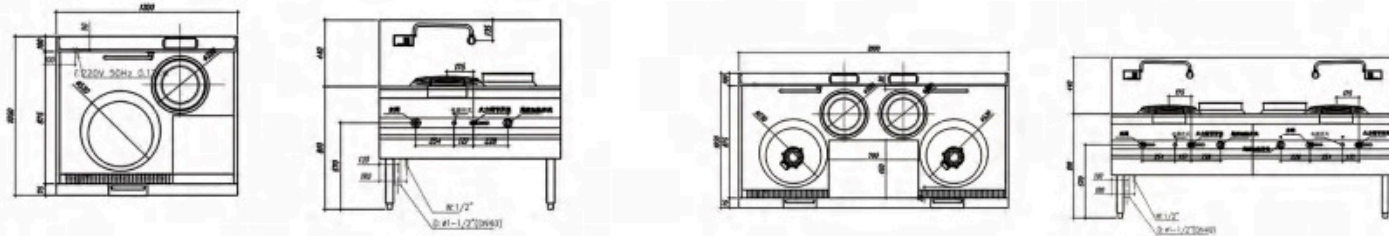

中式電磁炒爐系列 | Chinese Induction Wok Range

產品特征
FEATURES

20kw大功率電磁爐,整體臺面壹體成型
鋼體採用2.5mm的不銹鋼壹體成型
電磁爐無明火、無廢氣，可減少環境汙染
電磁感應加熱，熱效率高達95%以上
微電腦溫控系統，具有無鍋檢測
設置超溫，自動故障檢測，電壓過高過低及缺相保護等
火力電子顯示，多檔火力調節，功率漸進式可調
雙重金屬殼遮罩設計，防止電磁輻射

20KW higher power heating core. One punched work top and
cooking wok.
No open flame, no flue gas emission, reduces environmental
polluting.
Electromagnetic heating, microcomputer temperature control
system, thermal efficiency is over 95%
Equipped with no pot detection, over temperature protection,
automatic fault detection, voltage abnormally and open phase
protection.
Adjustable gradual model heating type with digital display.
Double-layered SS shell can prevent electromagnetic radiation

大功率電磁爐系列 High power induction cooker series



產品名稱 Product Name	型號 Model	規格(mm) Specification	熱負荷 Gas power	電壓 Voltage	進水/排水 Water inlet / drainage	標配 Standard
中式電磁單頭大炒爐	MLWC-1PN-E20	1200*1050*810	18kW	380V/50Hz	DN15/DN40	水龍頭 炒鍋
中式電磁雙頭大炒爐	MLWC-2PN-E20	2100*1050*810	18kW*2	380V/50Hz	DN15/DN40	水龍頭 炒鍋
中式電磁單頭大炒爐	MLWC-1P-E20	1200*1200*810	20kW	380V/50Hz	DN15/DN40	水龍頭 炒鍋
中式電磁雙頭大炒爐	MLWC-2P-E20	2100*1200*810	20kW*2	380V/50Hz	DN15/DN40	水龍頭 炒鍋

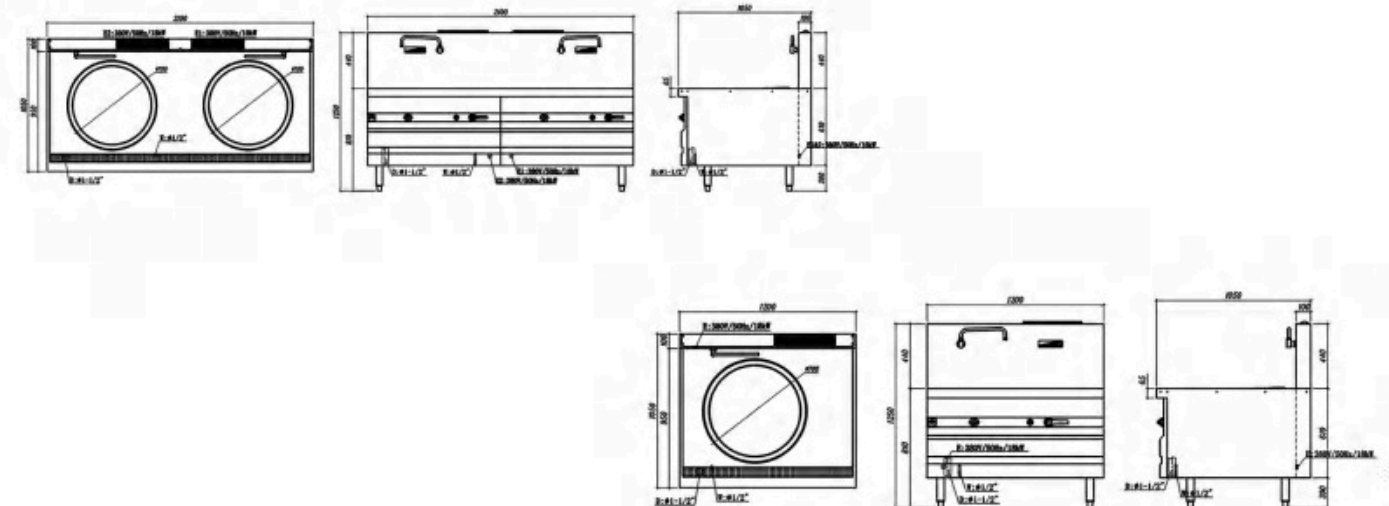

西式電磁爐具系列 | Western Induction Range

產品特征 FEATURES

全不銹鋼機身結構; 可調不銹鋼腳, 放置平穩
 采用SU304#2.0mm厚工作臺面
 微晶玻璃面板
 具有無鍋檢測、超溫保護、電壓過高過低以及缺相保護
 電磁感應加熱, 升溫快, 熱效率高達90%以上
 進口IGBT,IGBT過熱保護
 微晶腦精密控制火力, 功效漸進式可調

Completely SS body. One punched worktop with 2mm thickness.
 Adjustable SS feet convenient for install.
 Glass ceramics plate
 Electromagnetic heating ,microcomputer temperature control system, thermal efficiency is over 90%
 Equipped with no pot detection, over temperature protection, automatic fault detection, voltage abnormally and open phase protection.
 Imported IGBT over temperature protection
 Microcomputer temperature control system, Adjustable gradual model heating type with digital display

落地式電磁平頭爐系列 Floor stand induction Range with hobs series



產品名稱 Product Name	型號 Model	規格(mm) Specification	熱負荷 Gas power	電壓 Voltage
電磁雙頭平頭爐連下儲物櫃	M-LEMPF4N-E	400*750*850	3.5kW*2	220V/50Hz
電磁四頭平頭爐連下儲物櫃	M-LEMPF8N-E	800*750*850	3.5kW*4	380V/50Hz
電磁六頭平頭爐連下儲物櫃	M-LEMPF12N-E	1200*750*850	3.5kW*6	380V/50Hz
電磁雙頭平頭爐連下儲物櫃	M-LEMPF4H-E	400*900*850	3.5kW*2	220V/50Hz
電磁四頭平頭爐連下儲物櫃	M-LEMPF8H-E	800*900*850	3.5kW*4	380V/50Hz
電磁六頭平頭爐連下儲物櫃	M-LEMPF12H-E	1200*900*850	3.5kW*6	380V/50Hz
電磁四頭平頭爐連下焗爐	M-LEMPF8N-O-E	800*750*850	3.5kW*4+6kW	380V/50Hz
電磁六頭平頭爐連下焗爐	M-LEMPF12N-O-E	1200*750*850	3.5kW*6	380V/50Hz
電磁四頭平頭爐連下焗爐	M-LEMPF8H-O-E	800*900*850	3.5kW*4+6kW	380V/50Hz
電磁六頭平頭爐連下焗爐	M-LEMPF12H-O-E	1200*900*850	3.5kW*6+6kW	380V/50Hz

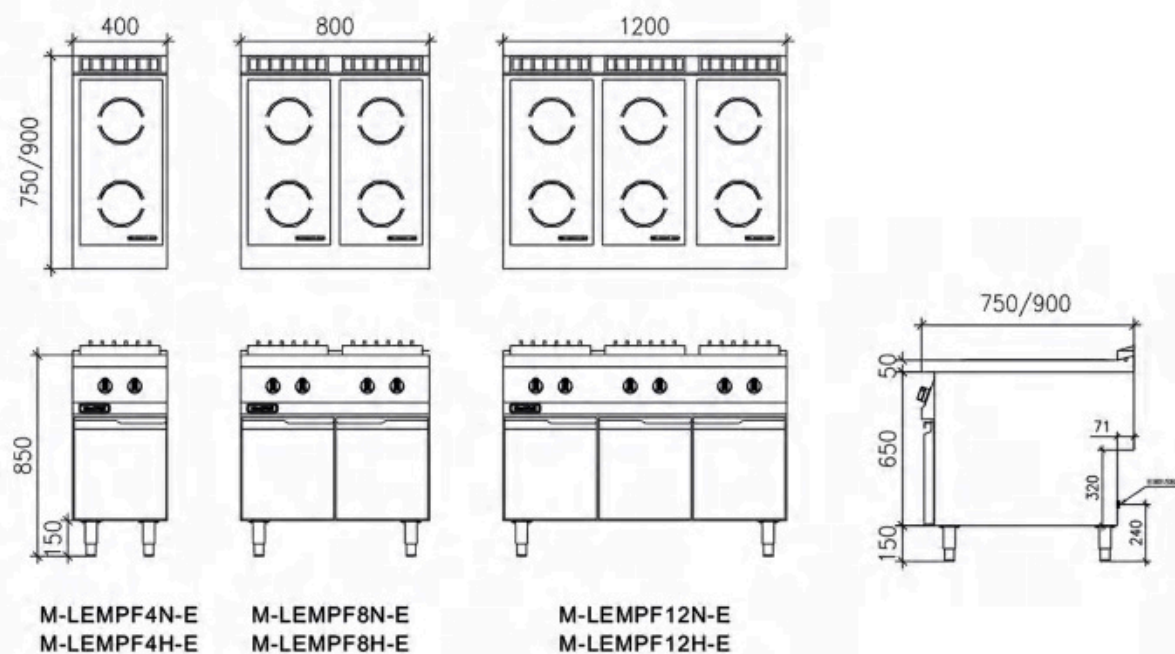

西式電磁爐具系列 | Western Induction Range

產品特征 FEATURES

全不銹鋼機身結構; 可調不銹鋼腳, 放置平穩
 采用SU304#1.5mm厚工作臺面, 整體沖壓成型
 微電腦控制系統
 進口凹面玻璃, 與炒鍋弧面達到完美結合
 具有無鍋檢測、超溫保護、電壓過高過低及缺相等保護
 電磁感應加熱, 升溫快、熱效率高達90%以上
 進口IGBT,IGBT過熱保護
 火力電子顯示; 微電腦精密控制火力, 功率漸進式可調

Completely SS body. One punched worktop with 2mm thickness.
 Adjustable SS feet convenient for install.
 Equipped with no pot detection, over temperature protection, automatic fault detection, voltage abnormally and open phase protection.
 Electromagnetic heating ,microcomputer temperature control system, thermal efficiency is over 90%
 Imported concave glass, perfectly combines with worktop.
 Imported IGBT over temperature protection
 Adjustable gradual model heating type with digital display

落地式電磁炒爐系列 Floor stand induction range with wok series



產品名稱 Product Name	型號 Model	規格(mm) Specification	熱負荷 Gas power	電壓 Voltage	備註 Remarks
電磁單頭炒爐連下櫃	M-LEMCZ8N-E	800*750*850	15kW	380V, 50Hz	配1個炒鍋水龍頭
電磁單頭單尾炒爐連下櫃	M-LEMCZ12N-E	1200*750*850	15kW	380V, 50Hz	配1個炒鍋水龍頭
電磁單頭炒爐連下櫃	M-LEMCZ8H-E	800*900*850	15kW	380V, 50Hz	配1個炒鍋水龍頭
電磁單頭單尾炒爐連下櫃	M-LEMCZ12H-E	1200*900*850	15kW	380V, 50Hz	配1個炒鍋水龍頭
電磁雙頭炒爐連下櫃	M-LEMCZ16H-E	1600*900*850	15kW*2	380V, 50Hz	配1個炒鍋水龍頭
電磁雙頭單尾炒爐連下櫃	M-LEMCZ18H-E	1800*900*850	15kW*2	380V, 50Hz	配1個炒鍋水龍頭

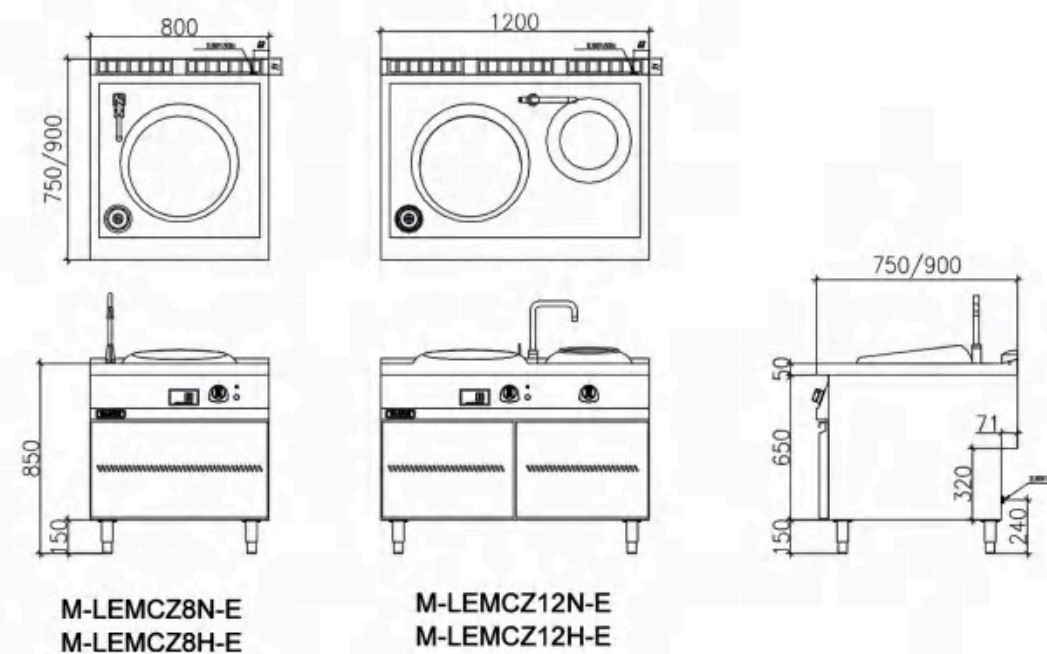

產品特征
FEATURES

大功率電磁爐矮湯爐。整體臺面衝壓成型。電磁爐無明火、無廢氣，可減少環境汙染。電磁感應加熱，熱效率高達90%以上。微電腦溫控系统，具有無鍋檢測。設置超溫，自動故障檢測，電壓過高過低及缺相保護等。火力電子顯示，多檔火力調節，功率漸進式可調。雙重金屬殼遮罩設計，防止電磁輻射。

Higher power heating core. One punched work top and cooking wok. No open flame, no flue gas emission, reduces environmental polluting. Electromagnetic heating, microcomputer temperature control system, thermal efficiency is over 90%. Equipped with no pot detection over temperature protection, automatic fault detection, voltage abnormally and open phase protection. Adjustable gradual model heating type with digital display. Double-layered SS shell can prevent electromagnetic radiation.

電磁矮湯爐系列 Electromagnetic Short Soup Stove Series



產品名稱 Product Name	型號 Model	規格(mm) Specification	熱負荷 Gas power	電壓 Voltage
電磁單頭矮湯爐	MLWS-1-E12	600*700*500	12kW	380V/50Hz
電磁單頭矮湯爐	MLWS-1-E15	600*700*500	15kW	380V/50Hz
電磁雙頭矮湯爐	MLWS-2-E12	1300*700*500	12kW*2	380V/50Hz
電磁雙頭矮湯爐	MLWS-2-E15	1300*700*500	15kW*2	380V/50Hz

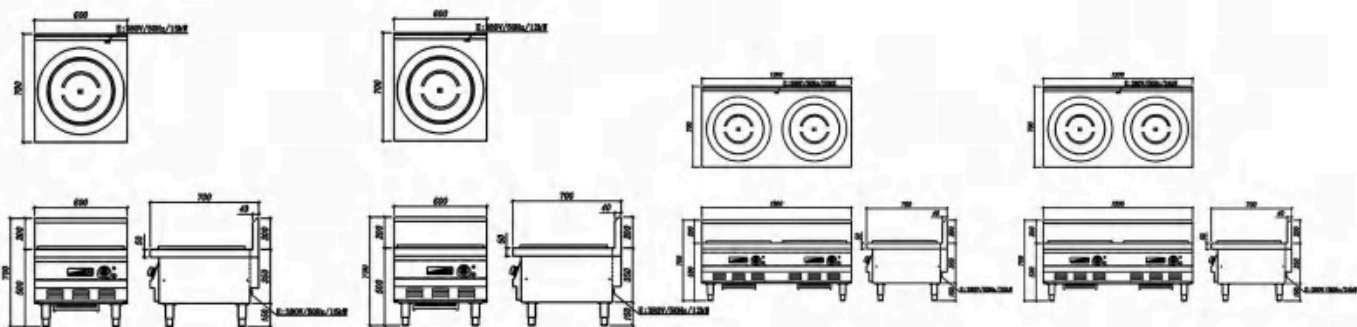

產品特征
FEATURES

高檔耐熱晶化玻璃面板，美觀大方，便於清潔維護。電磁感應原理對鍋具加熱，升溫快，熱效率高達90%以上，高效節能。具有無鍋檢測，超溫保護，自動故障檢測，電壓過高過低及缺相保護等，多檔火力調節，功率漸進式可調。

Heat-resistant Glass ceramics plate with beautiful appearance convenient for clean. Electromagnetic heating, microcomputer temperature control system, thermal efficiency is over 90%. Equipped with no pot detection over temperature protection, automatic fault detection, voltage abnormally and open phase protection. Adjustable gradual model heating type with digital display.

座臺式電磁爐系列 Seat type induction cooker series



產品名稱 Product Name	型號 Model	規格(mm) Specification	熱負荷 Gas power	電壓 Voltage
座臺式電磁雙頭平頭爐	M-TEMPF4N-E	400*700*290	3.5kW*2	220V/50Hz
座臺式電磁四頭平頭爐	M-TEMPF8N-E	800*700*290	3.5kW*4	380V/50Hz
座臺式電磁六頭平頭爐	M-TEMPF12N-E	1200*700*290	3.5kW*6	380V/50Hz

座臺式電磁爐系列-輕型 Seat type induction cooker series - lightweight

產品名稱 Product Name	型號 Model	規格(mm) Specification	熱負荷 Gas power	電壓 Voltage
座臺式電磁單頭平頭爐	MZTS-260T	350*410*75+20	2.6kW	220V/50Hz
座臺式電磁雙頭平頭爐	MZTS-260T2	700*410*75+20	2.6kW*2	220V/50Hz
座臺式電磁單頭平頭爐	MZTS-350T	350*410*75+20	3.5kW	220V/50Hz
座臺式電磁雙頭平頭爐	MZTS-350T2	700*410*75+20	3.5kW*2	220V/50Hz
座臺式電磁單頭炒爐	MZTSC-500T	400*550*220	5kW	380V/50Hz

嵌入式電磁爐系列 Built-in induction cooking range Series



產品名稱 Product Name	型號 Model	規格(mm) Specification	熱負荷 Gas power	電壓 Voltage
嵌入式電磁單頭平頭爐	MQTS-260K	340*340* (60+20)	2.6kW	220V/50Hz
嵌入式電磁雙頭平頭爐	MQTS-260K2	640*340*60	2.6kW*2	220V/50Hz
嵌入式電磁單頭平頭爐	MQTS-350K	350*350*75	3.5kW	220V/50Hz
嵌入式電磁雙頭平頭爐	MQTS-350K2	350*700*75	3.5kW*2	220V/50Hz
嵌入式電磁單頭炒爐	MQTSC-500K	400*500*260	5kW	380V/50Hz

萬能蒸烤箱系列

Combi oven



產品性能 PRODUCT PERFORMANCE

電熱萬能蒸烤箱系列分為6盤、10盤、20盤，可容納多種盤，微電腦自動控制集幹蒸、溫蒸和烘烤等功能於壹體可自行設定多種程式，設有緩沖加熱門開闔安全、蒸汽回饋功能、櫥內設置照明燈，方便觀察烤箱內烹飪的食物

The electric combi oven series consist of 6 trays, 10 trays, 20 trays. Automatic microcomputer control system Multi function for options, such as dry steam, wet steam, baking, roasting and so on. set up door safety switcher, steam recover function. set up inner illumination that convenient detection food cooking progress.

附件 Accessory

- 標配：
 6盤：每臺爐配壹把噴槍
 10盤：每臺爐配壹把噴槍
 20盤：每臺爐配壹把噴槍 20層推車壹臺
 選配：
 6盤、10盤可選擇是否配底座

- Standard:
 6 trays: Equipped with 1 PCS spray gun
 10 trays: Equipped with 1 PCS spray gun
 20 trays: Equipped with 1 PCS spray gun and 1 PCS of 20 layer trolley
 Optional:
 6 trays or 10 trays: Base holder for options.



烤箱底座



萬能蒸烤箱系列 | Combi Oven

產品特征 FEATURES

全不銹鋼機身結構;微電腦自動控制集幹蒸、濕蒸和烘烤等功能於壹體;自帶鍋體,蒸汽充分,鍋爐自動進水和缺水保護,防止乾燒裝置;設有緩沖加熱,門開闔安全,蒸汽反饋等功能;設有耐高溫玻璃門及櫥內照明燈,容易檢視操作情況|可24小時連續烹煮功能及1/2節省能源烹煮法
 幹燒溫度:30°C~300°C
 濕蒸溫度:30°C~300°C
 烘烤溫度:30°C~300°C

Completely SS body structure. Automatic microcomputer control system Multi function for options, such as dry steam, wet steam, baking, roasting and so on.
 Equipped with boiler tank to generate fully steam. set up automatic filling water and water lack protection, dry heating protection.
 Door safety switcher, steam recover function.
 Set up inner illumination that convenient detection food cooking progress. (Can be set full day running or energy-saving model)
 Roaster temperature: 30°C~300°C

萬能蒸烤箱——触摸屏款 Combi Oven——Touch Screen



萬能蒸烤箱——按鍵款 Combi Oven——Button



產品名稱 Product name	型號 Model	規格(mm) Specification (mm)	備註 Remarks
底座	F9078N	905x780x700	M-TSO6/1-E/M-TSO10/1-E/M-TSOC6/1-E/M-TSOC10/1-E用 可放10個1/1GN
底座	F1188N	1105x880x800	M-TSO10/2-E 可放7 個1/1和7個2/1GN盤

6盤、10盤烤箱可選配下底座, 20格萬能蒸烤理想隨機帶壹輛GN份盆推車。(份盆不包括)

Under Stand for Combi oven in 6 trays or 10 trays is optional; GN Trolley for 20 trays is standard (GN pans are not included)

產品名稱 Product Name	型號 Model	規格(mm) Specification	功率 power	電壓 Voltage	容量 capacity	容量 capacity
電熱萬能蒸烤箱(6*1/1GN)-觸摸屏	M-TSOC6/1-E	890*800*800	蒸 6kW, 烤 7.5kW, 混合烤7.5kW	380V,50Hz,	DN15/DN40	6*1/1GN
電熱萬能蒸烤箱(6*2/1GN)-觸摸屏	M-TSOC6/2-E	1125*890*800	蒸 12kW, 烤 7.5kW, 混合烤7.5kW	380V,50Hz,	DN15/DN40	6*1/1GN
電熱萬能蒸烤箱(10*1/1GN)-觸摸屏	M-TSOC10/1-E	890*800*1060	蒸 12kW, 烤 7.5kW, 混合烤7.5kW	380V,50Hz,	DN15/DN40	10*1/1GN
電熱萬能蒸烤箱(10*2/1GN)-觸摸屏	M-TSOC10/2-E	1125*890*1060	蒸 18kW, 烤 10kW, 混合烤10kW	380V,50Hz,	DN15/DN40	10*2/1GN
電熱萬能蒸烤箱(20*1/1GN)-觸摸屏	M-TSOC20/1-E	950*810*1864	蒸 18kW, 烤 20kW, 混合烤20kW	380V,50Hz,	DN15/DN40	20*1/1GN
電熱萬能蒸烤箱(20*2/1GN)-觸摸屏	M-TSOC20/2-E	1180*920*1864	蒸 30kW, 烤 20kW, 混合烤20kW	380V,50Hz,	DN15/DN40	20*2/1GN

產品名稱 Product Name	型號 Model	規格(mm) Specification	功率 power	電壓 Voltage	容量 capacity	容量 capacity
電熱萬能蒸烤箱(6*1/1GN)-按鍵款	M-TSO6/1-E	890*800*800	蒸 6kW, 烤 7.5kW, 混合烤7.5kW	380V,50Hz,	DN15/DN40	6*1/1GN
電熱萬能蒸烤箱(6*2/1GN)-按鍵款	M-TSO6/2-E	1125*890*800	蒸 12kW, 烤 7.5kW, 混合烤7.5kW	380V,50Hz,	DN15/DN40	6*1/1GN
電熱萬能蒸烤箱(10*1/1GN)-按鍵款	M-TSO10/1-E	890*800*1060	蒸 12kW, 烤 7.5kW, 混合烤7.5kW	380V,50Hz,	DN15/DN40	10*1/1GN
電熱萬能蒸烤箱(10*2/1GN)-按鍵款	M-TSO10/2-E	1125*890*1060	18kW, 烤 10kW, 混合烤10kW	380V,50Hz,	DN15/DN40	10*2/1GN
電熱萬能蒸烤箱(20*1/1GN)-按鍵款	M-TSO20/1-E	950*810*1864	蒸 18kW, 烤 20kW, 混合烤20kW	380V,50Hz,	DN15/DN40	20*1/1GN
電熱萬能蒸烤箱(20*2/1GN)-按鍵款	M-TSO20/2-E	1180*920*1864	蒸 30kW, 烤 20kW, 混合烤20kW	380V,50Hz,	DN15/DN40	20*2/1GN

橋架式組合爐

CANTILEVER EXECUTION



節能環保 安全可靠

Saving Environment Safety Reliability

整體高強度不銹鋼結構
獨特的安裝橋接和掛鉤設計
多種模塊選擇, 可按需組合
底部暢通, 便於清潔
完全適合大型和商業餐飲的特定要求
醫院、食堂、公司、學校、企業等
現場安裝 提供不同的設計, 輕鬆進行規劃
和安裝
“壁掛式安裝 牆式、立式”可以組合多種設
備
易於清潔, 堅固耐用
具有高設備和操作可靠性
人性化設計, 精緻的製造工藝

completely high strength stainless
steel structure.
Specialized bridge base holder and
hanger.
Multiple module for options, kinds of
combination as needs.
Emptying bottom for easy cleaning
Completely suitable for the catering
specific requirements of Hospitals,
companies, schools, enterprises, etc
provide Different designs and
installation type(Wall mounted, stand
floor). kinds of heating function for
options and combination.
Convenient for clean and quilt strong
and durable
Humanized design and exquisite
manufacturing crafts.



產品概述 PRODUCT OVERVIEW

標準版本 STANDARD VERSION

橋梁安裝

Bridge type



立牆安裝

Against the wall type



特征 FEATURES

- 全不銹鋼機身結構, 防水、防潮
Completely stainless steel body structure, waterproof, moisture proof
- 現場安裝可調不銹鋼腳, 放置平穩
Adjustable stainless steel feet on site for smooth placement
- 可更換單個功能
Replaceable cooking function
- 單個部件可更換
Replaceable cooking function.
- 安裝和維護成本最低
Low costs of installation and maintenance
- 設計不必要的拐角和接縫易於清潔
Without redundant corners and seams design ,convenient for clean.
- 嵌入式連接技術
Built-in connection type with high performance and high reliability
- 高性能高可靠性
High performance and reliability
- 獨特的安裝橋接和掛鉤設計
Unique installation bridge and hook design



特殊產品系列 操作安全方便

SPECIALTY EQUIPMENT SIMPLE & SAFE OPERATION

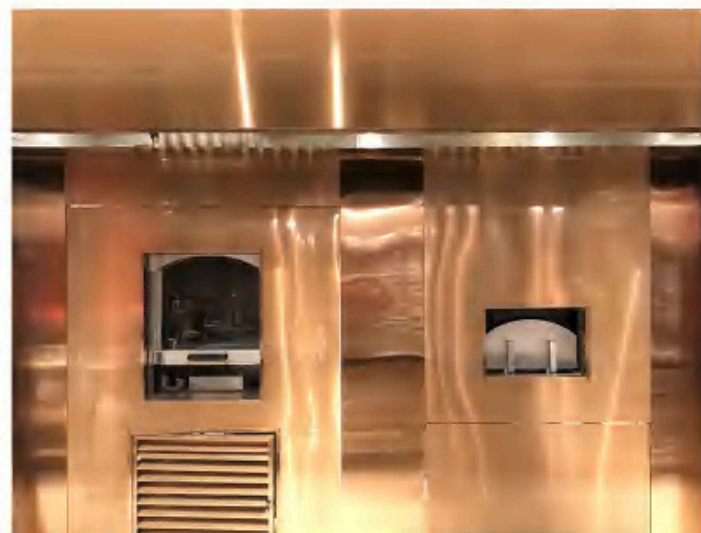

石窯類系列 Stone Stove Series



特殊產品系列 | Specialty Equipment_Oven

產品特征 FEATURES

電熱石窯披薩爐，採用弧形電熱管，耐火石板底設置有輔助加熱發功能，保證底部溫度足夠加熱披薩餅底

The stone pizza oven adopts arc heating pipe, and the bottom of the refractory slate is equipped with auxiliary heating function to ensure sufficient temperature at the bottom.

石窯類披薩爐燃氣系列 Stone kiln pizza stove gas series



產品名稱 PRODUCT NAME	燃氣單口披薩爐	燃氣雙口披薩爐連燒烤爐
型號 Model	M-CPO48F-G	M-CPR-140W
規格(mm) Specification (mm)	Φ1200x1600+360	1600x1375x1500+400
熱負荷 Gas power	14kW+5kW=19kW	16kW+9kW+3kW=28kW
耗電量 Power consumption	220V/0.025kW	220V/0.025kW
進氣口 Gas inlet	DN20	DN20
進水口/排水口 Water inlet / outlet	DN15/DN40	DN15/DN40
備註 Remarks	內設觀賞火焰 外部裝飾由客戶承建	內設觀賞火焰 外部裝飾由客戶承建



石窯類披薩爐電熱系列 Electric heating series of stone kiln pizza stoves

產品名稱 PRODUCT NAME	電熱圓形披薩爐	電熱石窯披薩爐連燒烤爐
型號 Model	M-CPO48F-E	M-CPR-140E
規格(mm) Specification (mm)	Φ1200x1600+360	1600x1375x1500+460
電功率 Electric power	22.5kW	27kW
電源 Power Supply	380V/50Hz	380V/50Hz
入水口 water inlet	Φ1/2" (DN15)	Φ1/2" (DN15)
排水口 Water outlet	Φ1-1/2" (DN40)	Φ1-1/2" (DN40)



產品特征
FEATURES

方型或圓型結構，炭（果木）電、燃氣熱源選擇，可選不帶裝飾（現場包裝）不銹鋼裝飾或其他耐火裝飾，烤架有掛式和旋轉兩種結構，鐵質外殼內襯特制耐火泥。0.400℃可調溫度自動控制，特設閥門（燃氣的），檔位開關（電熱的）或風門調節（炭的）實現火力控制，保持烤鴨過程爐內溫度穩定。配置防火水箱，排氣口溫度90-120℃（可調）自動洒水，達到350℃自動切斷燃氣或電供應。排風口200x200需配置抽風量不小於580m/h的風管，也可選擇設備自帶風機。

Square or round structure, carbon (fruit wood) electric and gas heat source selection, optional without decoration (on-site packaging) stainless steel decoration or other fire-resistant decoration, the grill has hanging and rotating structures, and the iron shell is lined with special fire-resistant clay liner. 0.400 °C adjustable temperature automatic control, special valve (gas), gear switch (electric) or damper adjustment (carbon) to realize fire control and maintain the stability of temperature in the oven during roast duck. Equipped with fire-proof sprinkler tank, the temperature of exhaust port is 90-120 °C (adjustable) and the automatic drinking water can automatically cut off the gas or electricity supply when it reaches 350 °C. The exhaust outlet 200x200 needs to be equipped with an air duct with an exhaust volume of not less than 580m / h, or the fan provided by the equipment can be selected

燃氣石窯北京燒鴨爐系列 Gas Stone Kiln Beijing Duck Stove Series



產品名稱 PRODUCT NAME	燃氣石窯北京燒鴨爐 (方形)	燃氣石窯北京燒鴨爐 (圓形)
型號 Model	M-PDO-120W	M-PDO-100W
規格(mm) Specification (mm)	1400*1200*2200	Φ1200*2400
電功率 Electric power	27kW	18kW
電源 Power Supply	220V/50Hz	220V/50Hz
進氣口 Air intake	DN20	DN20
進水口/排水口 Water inlet / outlet	DN15/DN40	DN15/DN40

電熱石窯北京燒鴨爐系列 Electric Stone Kiln Beijing Roast Duck Stove Series



產品名稱 PRODUCT NAME	電熱石窯北京燒鴨爐 (圓形)
型號 Model	M-PDO-100E
規格(mm) Specification (mm)	Φ1200*2450
電量 Electric power	18kW
電壓 Power Supply	380V/50Hz
入水口 water inlet	Φ1/2" (DN15)
排水口 Water outlet	Φ1-1/2" (DN40)

產品特征
FEATURES

耐火材料澆築內腔，圓弧角設計有利熱量傳導；特設果木燃燒系統，可以通過風門調節控制燃燒速度，來控制爐內溫度；配重上下拉門，操作輕便，並且可以通過門高度調節爐內上下層的溫度；可選擇在左邊或右邊設置果木添加窗口（標準在左面），窗口側需要預留不小於500mm的操作位置；特設防火灑水系統，自動向節油盆內加水，抽煙溫度超過140度自動灑水降溫；鐵制外殼，內膽特製整體耐火泥；需配置抽風，抽風量大於580m³/h；外部裝飾由客戶承建；安裝時需接駁220V/50Hz/0.025kW

Heat resisting material chamber with arc type which convenient for heating transfer. Special design wood combustion system, temperature control by adjustable wind window. Equipped with weight balance door to adjust upper layer and down layer temperature. Selection of left side or right side wood addition window(Standard: left side) which need more than 500mm operation space. Special designed water spray cooling device. automatic filling water into the water pan and Automatic open spray device when the flue arrived 140°C. equipped with iron shell with special integral heat resisting chamber. Need equipped with exhaust fan with wind capacity over 580m³/h. External decoration by customer and need power supply 220V/50Hz/0.025KW when installation

燃氣石窯類披薩爐系列 Stone kiln pizza stove gas series



產品名稱 Product name	石窯果木煙熏爐
型號 Model	M-CSO-36W
規格(mm) Specification (mm)	1000x1200x2050
主能源 Main energy source	果木和木炭
耗電量 Power consumption	220V/0.025
進水口/排水口 Water inlet / outlet	DN15/DN40
備註 Remarks	外部裝飾由客戶承建

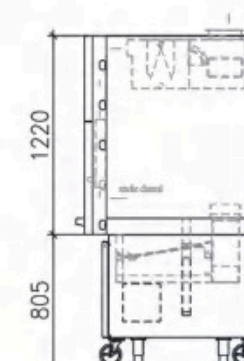
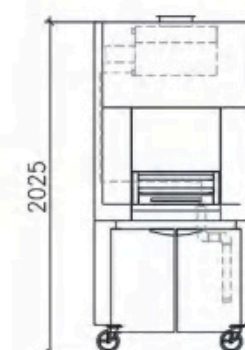
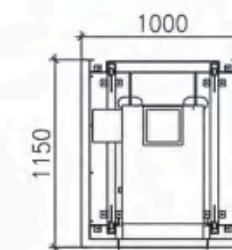



產品特征 FEATURES

此系列爐具可根據客戶要求設計扒爐、燒烤爐、半燒烤半扒爐
不銹鋼框架式的結構，設置可調子彈腳，方便安裝調節
周邊採用卡固結構的活動裙腳擋水板
3.0mm 無縫臺面，表面手工無序紋路
配置抽拉式活動的盛油盆，易於油脂收集及清潔

This series cooking stove can be custom made griddle, grill, half grill & half griddle according to customer requirement. Completely SS frame structure, Adjustable SS feet convenient for install. Removable water proof board. 3mm full welding countertop with polish treatment. Equipped with drawer type grease tray, convenient collection grease.

扒爐/GRIDDLE

18mm 厚的磨砂精鋼扒板
恆溫控制，100°C~300°C可調
設置420°C超溫保護，可手動復位

18mm heating board made by premium stainless steel and full welding with the worktop.
Adjustable temperature range 100°C-300°C, set up 420°C over temperature protection. with manual reset

燒烤爐/Grill

ø1200 以上尺寸可設置旋轉刀叉，
獨特的可拆卸耐火鑄鐵搪瓷燒烤架，
防止燒烤殘油汙染食物

Can be equipped with rotate fork once diameter over Φ1200,
Removable heat-resisting cast iron grid prevent the grease polluting food



燃氣系列 Gas series

產品名稱 Product name	型號 Model	規格(mm) Specification (mm)	電功率 Electric Power	熱負荷 thermal load	備註 Remarks
燃氣圓形燒烤爐	M-CBBS12H-G	Φ1200x850		36kW	
燃氣圓形燒烤爐	M-CBBS15H-G	Φ1500x850	220V/120W	36kW	4只獨立旋轉刀叉
燃氣圓形平扒爐	M-CGRF12H-G	Φ1200x850		36kW	
燃氣圓形平扒爐	M-CGRF15H-G	Φ1500x850		36kW	
燃氣圓形半平扒半燒烤爐	M-CBBS12H-F-G	Φ1200x850		36kW	
燃氣圓形半平扒半燒烤爐	M-CBBS15H-F-G	Φ1500x850	220V/120W	36kW	4只獨立旋轉刀叉

電熱系列 Electric Series

產品名稱 Product name	型號 Model	規格(mm) Specification (mm)	電壓 Voltage	電功率 Electric Power	備註 Remarks
電熱圓形燒烤爐	M-CBBS12H-E	Φ1200x850	380V/50Hz	14kW	
電熱圓形燒烤爐	M-CBBS15H-E	Φ1500x850	380V/50Hz	18kW	4只獨立旋轉刀叉
電熱圓形平扒爐	M-CGRF12H-E	Φ1200x850	380V/50Hz	18kW	
電熱圓形平扒爐	M-CGRF15H-E	Φ1500x850	380V/50Hz	18kW	
電熱圓形半平扒半燒烤爐	M-CBBS12H-F-E	Φ1200x850	380V/50Hz	16.5kW	
電熱圓形半平扒半燒烤爐	M-CBBS15H-F-E	Φ1500x850	380V/50Hz	18.1kW	4只獨立旋轉刀叉

Φ900圓形爐具系列

Ø900 round stove



產品性能 PRODUCT PERFORMANCE

Φ900圓形組合式爐具系列,是壹組具有較強人機親和介面的特色爐具,整體結構主爐具,輔助搭配橋板,醬料臺及扶手等配件組成。這合於酒店特色開放式廚房。主體爐具功能有:電磁(燃氣)炒爐、電熱(燃氣)蒸爐、電熱(燃氣)煮面爐、電熱(燃氣)湯鍋、電熱扒爐、電熱(燃氣)燒烤爐及電熱多功能爐等。搭配橋板可以設置協助工具,如電磁平頭爐、保溫板、冰盆及保溫湯池等。配置豐富,組合多洋。可以根據使用者的需求和習慣進行不同的選擇、搭配及組合。產品圍身根據餐廳的設計風格選擇不同的烤漆顏色

Φ900 circular stove series: Completely SS body structure which suitable for open kitchen and hotel.
Accessory equipped with connection board,season board,handle for options.
Mainly heating function can be designed induction (gas)cooking wok, electric (gas)steamer ,electric (gas) pasta cooker,electric (gas) kettle,electric griddle,electric (gas) grill etc.
The connection board can be put induction open burner, warmer plate, ice bin,and Bain Marie.
Multi function combination for options.
Kinds of appearance painting color for options base on restaurant decoration type.



Φ900圓形爐具系列 | Specialty Equipment_ Ø900 round stove

產品特征 FEATURES

多檔位火力調節; 自動無鍋檢測功能
友好的人機界面, 操作方便
不銹鋼制造; 360°無死角, 便於清潔
搭配橋板可以設置協助工具,如電磁平頭爐、保溫板、冰盆及保溫湯池等; 配置豐富,組合多洋
可以根據使用者的需求和習慣進行不同的選擇、搭配及組合; 產品圍身根據餐廳的設計風格選擇不同的烤漆顏色

Completely SS body structure. Adjustable gradual model heating type with digital display. Equipped with no pot detection. The connection board can be put induction open burner, warmer plate, ice bin, and Bain Marie.
Multi function combination for options.
Kinds of appearance painting color for options base on restaurant decoration type.

圓形炒爐 Round induction wok



產品名稱 Product name	圓形炒爐
型號 Model	D90-1EC-E
規格(mm) Specification (mm)	900(D)x900(H)
電功率 Electric power	15kW
電源 Power Supply	380V/50Hz
入水口 water inlet	Φ1/2" (DN15)鋼管或不銹鋼管
排水口 Outfall	Φ1-1/2" (DN40)



圓形蒸爐 Round steamer



產品名稱 Product name	圓形蒸爐
型號 Model	D90-SC-E
規格(mm) Specification (mm)	900(D)x900(H)
電功率 Electric power	27kW
電源 Power Supply	380V/50Hz
入水口 water inlet	Φ1/2" (DN15)鋼管或不銹鋼管
排水口 Outfall	Φ1-1/2" (DN40)

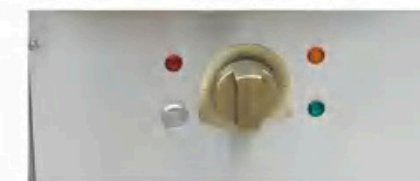

產品特征
FEATURES

多檔位火力調節60°C-350°C無極溫度調節
自動超溫保護功能；友好的人機界面，操作方便
不銹鋼製造；16mm度烙扒板；360°無死角，便於清潔
搭配橋板可以設置協助工具,如電磁平頭爐、保溫板、冰盆
及保溫湯池等；配置豐富,組合多洋
可以根據使用者的需求和使用習慣進行不同的選擇、搭配及
組合；產品圖身根據餐廳的設計風格選擇不同的烤漆顏色

Adjustable temperature range 60°C-350°C, Automatic
over temperature protection. Completely SS body
structure. 18mm heating board made by premium
stainless steel and full welding with the worktop. The
connection board can be put induction open burner,
warmer plate, ice bin, and Bain Marie.
Multi function combination for options.
Kinds of appearance painting color for options base on
restaurant decoration type.

圓形扒爐 Round griddle



產品名稱 Product name	圓形扒爐
型號 Model	D90-L1RG-E
規格(mm) Specification (mm)	900(D)x900(H)
電功率 Electric power	9kW
電源 Power Supply	380V/50Hz



圓形燒烤爐 Round grill



產品名稱 Product name	圓形燒烤爐
型號 Model	D90-LBS-E
規格(mm) Specification (mm)	900(D)x900(H)
電功率 Electric power	9kW
電源 Power Supply	380V/50Hz



產品特征
FEATURES

多檔位火力調節60°C-350°C無極溫度調節
自動超溫保護功能；友好的人機界面，操作方便
不銹鋼製造；16mm度烙扒板；360°無死角，便於清潔
搭配橋板可以設置協助工具,如電磁平頭爐、保溫板、冰盆
及保溫湯池等；配置豐富,組合多洋
可以根據使用者的需求和使用習慣進行不同的選擇、搭配及
組合；產品圖身根據餐廳的設計風格選擇不同的烤漆顏色

Adjustable temperature range 60°C-350°C, Automatic
over temperature protection. Completely SS body
structure. 18mm heating board made by premium
stainless steel and full welding with the worktop. The
connection board can be put induction open burner,
warmer plate, ice bin, and Bain Marie.
Multi function combination for options.
Kinds of appearance painting color for options base on
restaurant decoration type.

圓形煮面爐 Round noodle boiler



產品名稱 Product name	圓形煮面爐
型號 Model	D90-PC-E
規格(mm) Specification (mm)	900(D)x900(H)
電功率 Electric power	9kW
電源 Power Supply	380V/50Hz
入水口 water inlet	Φ1/2" (DN15)鋼管或不銹鋼管
排水口 Outfall	Φ1-1/2" (DN40)



圓形湯爐 Round soup pot



產品名稱 Product name	圓形湯爐
型號 Model	D90-SPC-E
規格(mm) Specification (mm)	900(D)x900(H)
電功率 Electric power	9kW
電源 Power Supply	380V/50Hz
入水口 water inlet	Φ1/2" (DN15)鋼管或不銹鋼管
排水口 Outfall	Φ1-1/2" (DN40)

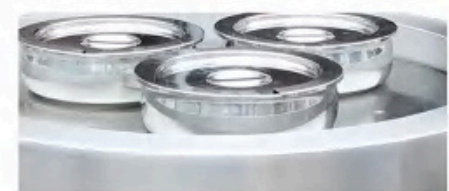

鏈式燒烤爐系列 Chain barbecue grill series

電熱系列 Electric Series

全不銹鋼機身結構
可調不銹鋼腳，放置平穩
採用SUS304#2.0mm厚工作臺面，
整體衝壓成型
獨立控制加熱系統
EGO檔位開關，精確控制火力
設置不銹鋼鏈條燒烤架，燒烤網用Ø8
鋼支持製
設有可放置1/3或1/6GN盆不銹鋼架
配置抽拉式活動的盛油盆，易於油脂
收集及清潔
可以烹飪肉、雞、魚和蔬菜等

Completely SS body. One punched worktop with 2mm thickness.
Adjustable SS feet convenient for install.
EGO temperature control device. kinds of food can be cooked.
Equipped with SS chain and grid, The season box can be placed 1/3 or 1/6GN pan.
Equipped with drawer type grease tray and drainage hole, convenient for collected grease and easily clean.



燃氣系列 Gas Series

全不銹鋼機身結構
可調不銹鋼腳，放置平穩
採用SUS304#2.0mm厚工作臺面，整體衝壓成型
設置長明火種
配備安全制(熱電偶熄火保護裝置)
採用與安全制聯動，自動脈衝電子點火
多檔火力調節
設置不銹鋼鏈條燒烤架，燒烤網用Ø8鋼支持製
設有可放置1/3或1/6GN盆

Completely SS body. One punched worktop with 2mm thickness.
Adjustable SS feet convenient for install.
Equipped with stand pilot and flame failure protection, automatic electronic pulse ignition. kinds of food can be cooked.
Equipped with SS chain and grid, The season box can be placed 1/3 or 1/6GN pan.
Equipped with drawer type grease tray and drainage hole, convenient for collected grease and easily clean..



炭烤系列 Charcoal Series

全不銹鋼機身結構
可調不銹鋼腳，放置平穩
設置不銹鋼鏈條燒烤架，燒烤網用Ø8鋼支持製
設有可放置1/3或1/6GN盆不銹鋼架
設置可調鮮風口
砌磚內膽
配置抽拉式活動的盛油盆，易於油脂收集及清潔
可以烹飪肉、雞、魚和蔬菜等

Completely SS body structure. Adjustable SS feet convenient for install.
Equipped with SS chain and grid, The season box can be placed 1/3 or 1/6GN pan. kinds of food can be cooked.
Equipped with adjustable fresh air window, Fire resisting bricks chamber
Equipped with drawer type grease tray and drainage hole, convenient for collected grease and easily clean.



鏈式燒烤爐系列 Chain barbecue grill series

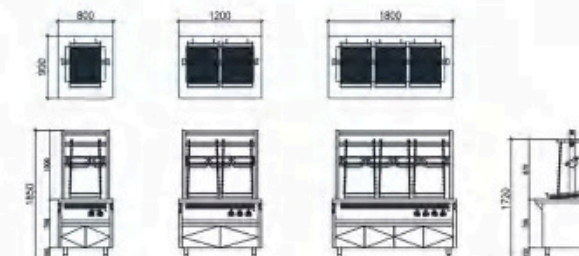

燃氣系列 Gas series

產品名稱 Product name	型號 Model	規格(mm) Specification (mm)	熱負荷 thermal load	備註 Remarks
燃氣鏈式燒烤爐	M-ABS8H-G	800*900*850+1000	18kW	
燃氣鏈式燒烤爐	M-ABS12H-G	1200*900*850+1000	27kW	
燃氣鏈式燒烤爐	M-ABS16H-G	1600*900*850+1000	36kW	

電熱系列 Electric Series

產品名稱 Product name	型號 Model	規格(mm) Specification (mm)	熱負荷 thermal load	電壓 Voltage
電熱鏈式燒烤爐	M-ABS8H-E	800*900*850+1000	18kW	380V/50Hz
電熱鏈式燒烤爐	M-ABS12H-E	1200*900*850+1000	27kW	380V/50Hz
電熱鏈式燒烤爐	M-ABS16H-E	1600*900*850+1000	36kW	380V/50Hz

碳熱系列 Charcoal Series

產品名稱 Product name	型號 Model	規格(mm) Specification (mm)	備註 Remarks
碳熱鏈式燒烤爐	M-ABS8H-C	800*900*850+1000	
碳熱鏈式燒烤爐	M-ABS12H-C	1200*900*850+1000	
碳熱鏈式燒烤爐	M-ABS16H-C	1600*900*850+1000	

升降燒烤爐系列

LIFTING BBQ EQUIPMENT



產品特征 Features

升降 燒烤架可以選擇通過電動或手動轉輪，渦輪桿與絲桿絲母的組合結構可以輕鬆拎起 200kg的重物且具備自鎖定位，不會滑落。裝飾火焰是利用霧光的原理，燈光照在水霧上產生火苗燃燒的特效，安全無害，可以調節室內溫度，還可以添加精油，有香薰的作用。

The lifting grid can be selected electric driving or manual rotate, easily lift 200kg weight objects and set up self-locking device to prevent slide. Designed light decoration with strongly visual effect. Can be added essence oil for air fumigation.

燃氣 Gas:

配備電磁安全置，壹鍵操作，自動脈沖點火，熄火閉閥時間1s，安全耐用盛油盆設置滿水口電磁閥自動補水，盛油盆水可以起到隔熱和反射熱量的作用爐頭防油汙堵塞，專用燒烤石，輻射效率高，耐用不易摔。

Equipped with safety device and One-button operation, electronic pulse ignition. As will be cut off in 1 second once flame failure. Equipped with heat reflect water pan, automatic filling water device, Durable lava stone with high radiation efficiency.

電熱 Electric:

3組 每組3根1.5kw 840材質的燒烤爐專用發熱管，每組獨刀控制火力，底部密封，圓角圓邊燒烤盆，電磁閥自動補水，設置滿水口燒烤時下部的水可以起到隔熱和反射熱量的作用發熱管翻起設計方便清潔水盆

Designed 3 group 840 material heating elements with independent control, 3*1.5kw of per group. Equipped with heat reflect water pan and automatic filling water device.

碳熱 Charcoal:

活動炭盆，方便清潔和生火操作，設置可調節風門，控制火大小外爐膽設置保溫層及通風結構，避免爐體高溫

Equipped with removable charcoal pan, convenient for clean and ignition. Set up adjustable air window, warmer and ventilation device to avoid high temperature of the equipment body.

燒烤爐系列

Grill Series

產品特征 Features

通過升降燒烤架改變食物與火源的距離，可滿足不同的燒烤要求。活動炭盆，方便清潔和生火操作，設置可調節風門，控制火大小外爐膽設置保溫層及通風結構，避免爐體高溫

燒烤爐可以選擇用木炭、電或燃氣加熱。電熱每組3根1.5kw 840材質的燒烤爐專用發熱管，每組獨刀控制火力，底部密封。燃氣配備電磁安全置，壹鍵操作，自動脈沖點火，熄火閉閥時間1s，安全耐用盛油盆設置滿水口電磁閥自動補水，盛油盆水可以起到隔熱和反射熱量的作用爐頭防油汙堵塞，專用燒烤石，輻射效率高，耐用不易摔。

櫃體可以選擇不銹鋼原色或根據裝修需求選擇不用顏色的烤漆。櫃體可選配暖碟櫃，雪櫃，垃圾桶等功能。配備醬料盒，方便使用，採用搪瓷烤網

The distance between the food and the fire source could be changed through the rise and fall barbecue grill, which could meet different barbecue requirements. It was easy to move the charcoal basin, which was convenient for cleaning and making fire. Besides, it was equipped with an adjusting air door, an insulation layer and a ventilation structure to control the power of the fire outside the furnace, so as to avoid high temperature of the furnace

The grill could be heated with charcoal, electricity or gas. Each group had 3 heating tubes made of 1.5KW or 840 barbecue grills. Each group had one knife to control the heat and the bottom was sealed. It was equipped with an electric safety gear, one key operation, and automatic impulse firing. The extinguishing time was 1s, and a safe and durable oil basin was set with an automatic water replenishing system. The water in the oil basin could be used to heat and reflect heat, and the furnace head could be blocked by oil stains. The special barbecue stone was highly radiation and it was durable and not easy to fall.

The cabinets could be painted in the same color as the original color of the steel, or in different colors according to the decoration needs. The cabinets could be equipped with other functions such as the warming up cupboard, the fridge and the trash can. It was equipped with a soy sauce box, which was convenient to use and baked with a porcelain net

燃氣系列 Gas series

產品名稱 Product name	型號 Model	規格(mm) Specification (mm)	電源 Power Supply	電功率 Electric Power	熱負荷 thermal load	進水口 Water Inlet	排水 Drainage	進氣口 Gas Inlet
燃氣升降燒烤爐	LBS-3G	1800*750*850	220V/50Hz	0.02	27kW	DN15	DN40	DN20
燃氣電動升降燒烤爐	LBS-3GM	1800*750*850	220V/50Hz	0.27	27kW	DN15	DN40	DN20
燃氣電動升降燒烤爐	LBS-3GF	1800*1050*850	220V/50Hz	0.02	27kW	DN15	DN40	DN20
燃氣電動升降燒烤爐連裝飾火	LBS-3GD	1800*1050*850	220V/50Hz	0.27	27kW	DN15	DN40	DN20

電熱系列 Electric Series

產品名稱 Product name	型號 Model	規格(mm) Specification (mm)	電源 Power Supply	電功率 Electric Power	熱負荷 thermal load	進水口 Water Inlet	排水 Drainage	進氣口 Gas Inlet
電熱升降燒烤爐	LBS-3E	1800*750*850	380V/50Hz	18.25kW	/	DN15	DN40	DN20
電熱電動升降燒烤爐	LBS-3EM	1800*750*850	380V/50Hz	18.25kW	/	DN15	DN40	DN20
電熱電動升降燒烤爐	LBS-3EF	1800*1050*850	380V/50Hz	18.27kW	/	DN15	DN40	DN20
電熱電動升降燒烤爐連裝飾火	LBS-3ED	1800*1050*850	380V/50Hz	18.27kW	/	DN15	DN40	DN20

碳熱系列 Charcoal Series

產品名稱 Product name	型號 Model	規格(mm) Specification (mm)	電源 Power Supply	備註 Remarks
碳熱升降燒烤爐	LBS-3C	1800*750*850	220V/50Hz	
碳熱電動升降燒烤爐	LBS-3CM	1800*750*850	220V/50Hz	
碳熱電動升降燒烤爐	LBS-3CF	1800*1050*850	220V/50Hz	
碳熱電動升降燒烤爐連裝飾火	LBS-3ED	1800*1050*850	220V/50Hz	

炭烤箱燒烤兩用爐

Carbon oven with grill function

碳烤箱系列 Carbon oven series



產品特征 FEATURES

是由碳烤爐及組合的新型新型炭烤箱，採用不銹鋼製成耐用且不易生銹；爐門特設不銹鋼耐高溫變形，編織袋耐高溫防撞密封特別設計
 承重能力強；食材均勻翻轉受熱，獨特的封閉式燒烤設計，不同層次的燒烤，既靈活又堅固，易於使用，帶有前開門，溫度通風系統。兩用爐，提升雙層玻璃門設計，升降燒烤方便燒烤使用控製

It is a new type of carbon oven composed of carbon oven and sheep grill. The sheep grill is made of stainless steel, durable and not easy to rust. Special stainless steel Woven fabric is specially designed for high temperature deformation and anti-collision sealing. Strong bearing capacity; The ingredients are evenly turned over and heated. The unique closed barbecue design, barbecue at different levels, is flexible, firm and easy to use. It is equipped with front door opening and temperature ventilation system. This Dual-function grill was designed with double glass doors, which was convenient for barbecue.



- 排廢氣防火帽 Exhaust gas fire cap
- 排廢氣閥 Exhaust valve
- 溫度表 Thermometer
- 門把手 Door handle
- 油盆 Oil basin
- 調風閥 Air regulating valve
- 碳灰盆 Carbon ash Basin
- 下櫃 Lower cabinet

燒烤爐系列

Grill Series

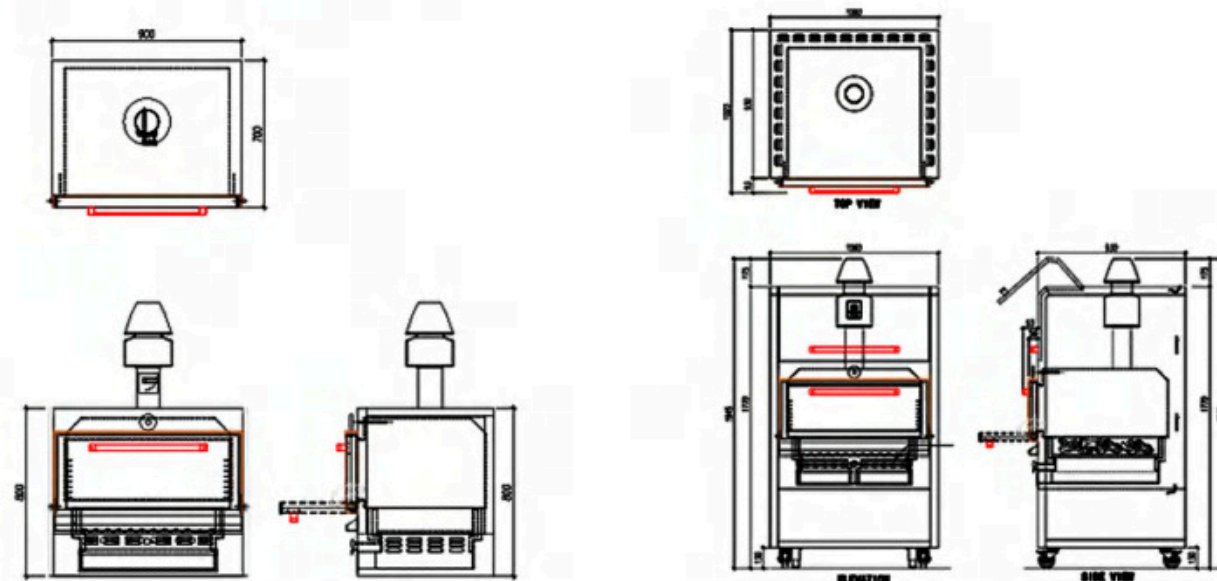

底櫃	配FCO-645用	640*700*650
base cabinet	配FCO-905用	900*700*650

座台式 Counter top

型號 Model	FCO-645	FCO-905
規格(mm) Specification (mm)	640*700*(800*293)	900*700*(800-293)
烤架尺寸 Grille size	500*510mm	760*510mm

櫃式 cabinet type

型號 Model	FCO-76M	FCO-102M
規格(mm) Specification (mm)	760*700*1940	1020*700*1940
烤架尺寸 Grille size	500*510mm	760*510mm

櫃式碳烤箱 (烤架可升降) Cabinet style carbon oven (grill adjustable)

型號 Model	FCO-80MD	FCO-106MD
規格(mm) Specification (mm)	800*700*1940	1060*700*1940
烤架尺寸 Grille size	500*510mm	760*510mm

頂火燒烤爐系列

TOP FIRED BROILER



燃氣 Gas:

採用陶瓷板紅外線燃燒器；使用爐火開關安全制控制，設置常明火種，安全制熄火保護，自動脈衝電子點火
adopt ceramic plate infrared burner; set up stand pilot fire, gas safety device, flame failure protection, automatic pulse electronic ignition

電熱 Electric:

採用優質紅外線發熱管，高效能發熱
high quality infrared heating tube, high heating efficiency



燒烤爐系列

Grill Series

產品特征 Features

MarkPhili頂火燒烤爐系列適用於各種燒烤食物的製作，有電熱和燃氣加熱兩種方式可選；此類燒烤爐主要是通過熱紅外線爐頭對食物表面進行加熱，這種設計能有效避免燒烤油渣與火接觸燃燒產生有害物質，同時保持食物的鮮味；配重升降架，輕鬆調節面火板與加熱食物之間的距離，確保食材的燒烤品質；設置抽拉式燒烤架，方便取放食物。

Markphili top fire barbecue grill series, which is used for the production of various barbecue foods. There are two options: electric heating and gas heating; This kind of barbecue grill mainly heats the food surface through the thermal infrared burner. This design can effectively avoid the contact combustion of barbecue oil residue with fire to produce harmful substances, and maintain the freshness of food at the same time; The counterweight lifting frame can easily adjust the distance between the surface fire plate and the heated food to ensure the barbecue quality of food materials; The barbecue grill was set up so that the food could be taken and placed conveniently.

燃氣系列 Gas series

產品名稱 Product Name	型號 Model	規格(mm) Specification (mm)	電源 Power Supply	電功率 Electric Power	熱負荷 thermal load
燃氣單層頂火燒烤爐	M-LMK1-G	900*900*1415+235	220V/50Hz	0.1kW	18kW
燃氣雙層頂火燒烤爐	M-LMK2-G	900*900*1650+235	220V/50Hz	0.1kW	18kW*2=36kW
燃氣頂火燒烤爐連扒爐	M-LMKG09-G	900*850*1150+285	220V/50Hz	0.1kW	30kW
燃氣頂火燒烤爐連扒爐	M-LMKG11-G	1100*850*1150+285	220V/50Hz	0.1kW	30kW

電熱系列 Electric Series

產品名稱 Product Name	型號 Model	規格(mm) Specification (mm)	電源 Power Supply	熱負荷 thermal load
電熱單層頂火燒烤爐	M-LMK1-E	900*900*1415+235	380V/50Hz	12kW
電熱雙層頂火燒烤爐	M-LMK2-E	900*900*1650+235	380V/50Hz	12kW*2=24kW
電熱頂火燒烤爐連扒爐	M-LMKG09-E	900*850*1150+285	380V/50Hz	24kW
電熱頂火燒烤爐連扒爐	M-LMKG11-E	1100*850*1150+285	380V/50Hz	24kW

座臺式款 Desktop style

產品名稱 Product Name	型號 Model	規格(mm) Specification (mm)	電源 Power Supply	熱負荷 thermal load
座臺式電熱頂火燒烤爐	M-TMK1-E	900*750*595+160	380V/50Hz	12kW
座臺式燃氣頂火燒烤爐	M-TMK1-G	900*750*595+160	220V/0.1kW	15kW

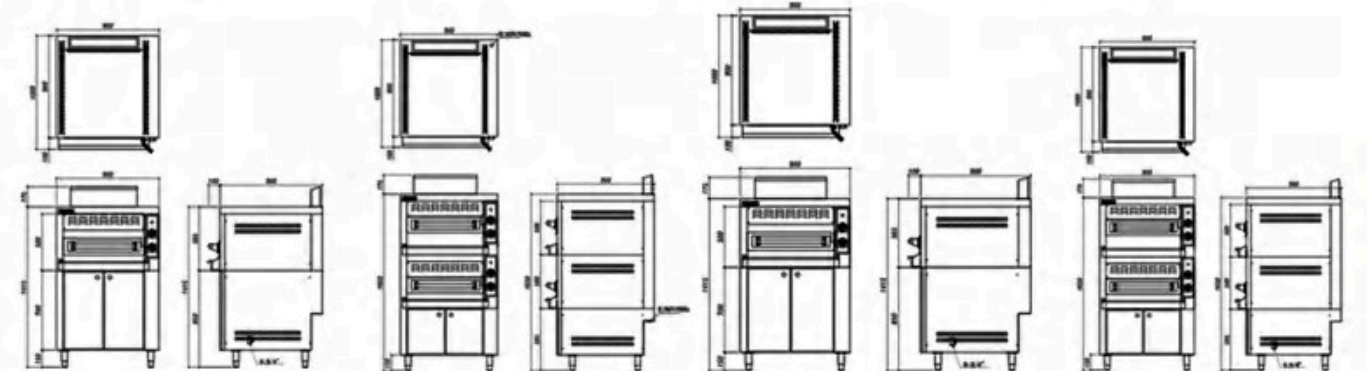

巴西燒烤爐系列

BRAZILIAN BBQ EQUIPMENT



產品性能 Product performance

耐火不銹鋼反熱板加熱，加熱速度快全不銹鋼機身結構。可調不銹鋼腳，放置平穩 火力調節反應快，獨特的可調角度耐火鑄鐵搪瓷燒烤架，防止燒烤殘油汙染食物，配置抽拉式活動的盛油盆，易於油脂收集及清潔。雙層烤叉，帶自動旋轉，燃氣採用與安全製聯動，自動脈衝電子點火，設置長明火種 配備安全製（熱電偶熄火保護裝置）安裝時需要預留220V/50Hz/，供電機使用，通過發熱管傳達熱量 多檔火力控制調節。可根據需求選擇不能規格及能源，我們提供燃氣、電熱及碳燒等加熱方式；可以烹飪肉雞、魚，火力調節反應快

Fire resistant stainless steel anti heat plate heating, fast heating speed, all stainless steel body structure. Adjustable stainless steel feet, stable placement, fast fire adjustment response, unique adjustable angle refractory cast iron enamel barbecue rack to prevent barbecue residual oil from polluting food, equipped with pull-out movable oil basin, easy to collect and clean oil. Double layer baking fork, with automatic rotation, gas linkage with safety system, automatic pulse electronic ignition, setting long open flame, equipped with safety system (thermocouple flameout protection device). During installation, 220V / 50Hz / needs to be reserved for motor use, and heat is transmitted through heating pipe for multi gear fire control and adjustment. Specifications and energy can be selected according to demand. We provide heating methods such as gas, electric heating and carbon burning; It can cook chicken and fish with fast fire regulation response



燒烤爐系列

Grill Series

產品特征 FEATURES

燃氣型：
設置常明火種；
配備安全製（熱電偶熄火保護裝置）
採用與安全製聯動 自動脈衝電子點火
安裝時需要預留220V/50Hz/110用電，供電機使用
電熱型：
通過發熱管傳達熱量 多檔火力控制調節

Gas type:equipped with stand pilot and safety device (thermocouple flame failure protection) .Automatic pulse electronic ignition. reserved 220 /110v 50 Hz power supply for motor during installation. Electric type:adopted premium heating elements, multi point control heating power.

燃氣系列 Gas series

型號 Model	規格(mm) Specification (mm)	耗電量 Power consumption	熱負荷 thermal load	容量 Capacity
M-LBBS8N-G	800*750*850	220V, 0.2kW	14kW	7支燒烤叉
M-LBBS12N-G	1200*750*850	220V, 0.2kW	21kW	13支燒烤叉
M-LBBS16N-G	1600*750*850	220V, 0.2kW	24kW	17支燒烤叉
M-LBBS8H-G	800*900*850	220V, 0.2kW	18kW	7支燒烤叉
M-LBBS12H-G	1200*900*850	220V, 0.2kW	27kW	13支燒烤叉
M-LBBS16H-G	1600*900*850	220V, 0.2kW	36kW	17支燒烤叉

電熱系列 Electric Series

型號 Model	規格(mm) Specification (mm)	電源 Power Supply	電功率 Electric Power	容量 Capacity
M-LBBS8N-E	800*750*850	380V/50Hz	9kW	7支燒烤叉
M-LBBS12N-E	1200*750*850	380V/50Hz	13.5kW	13支燒烤叉
M-LBBS16N-E	1600*750*850	380V/50Hz	18kW	17支燒烤叉
M-LBBS8H-E	800*900*850	380V/50Hz	12kW	7支燒烤叉
M-LBBS12H-E	1200*900*850	380V/50Hz	18kW	13支燒烤叉
M-LBBS16H-E	1600*900*850	380V/50Hz	24kW	17支燒烤叉

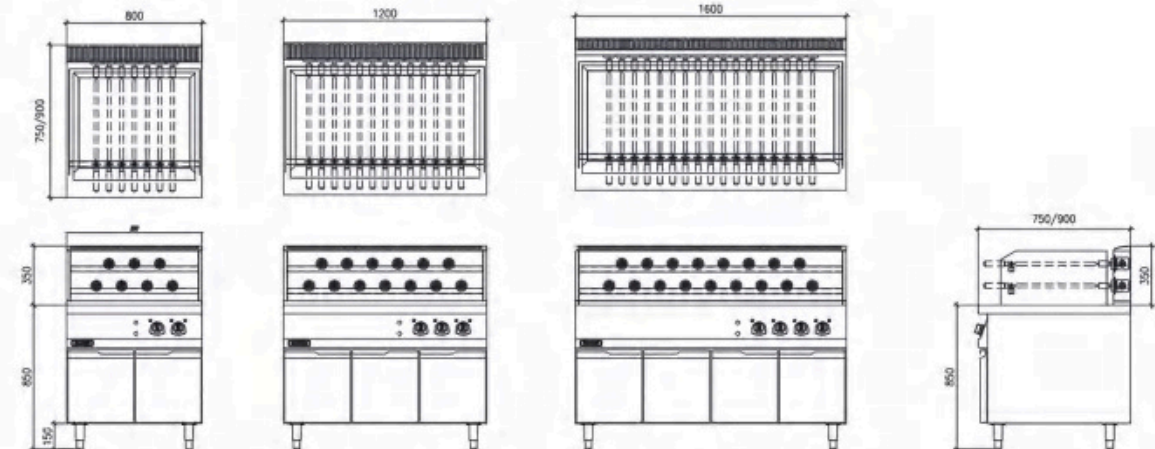

法式烤雞爐

ROTISSERIE



烧烤炉系列

Grill Series

产品特点 Features

燃气：點火：脈沖電子點火；熄火保護：爐火開關連安全製，設置長明火種；其他：電動旋轉鏈式烤叉機構，電機功率0.2K
 電熱：
 說明：每組三根840材質的燒烤用發熱管，每組獨立控制火力；
 其他：電動旋轉鏈式烤叉機構。
 熱量的作用發熱管翻起設計方便清潔水盆

Gas:
 Ignition: Electronic pulse ignition
 Safety device: Set up stand pilot fire, gas safety device with flame failure protection
 Others: Electric rotate chain fork structure, motor power: 0.2KW / 380V/50HZ
 Electric:
 Heating elements: Designed 3 group 840 material heating elements with independent control
 Others: Electric rotate chain fork structure

燃氣系列 Gas series

產品名稱 Product name	型號 Model	規格(mm) Specification (mm)	電功率 Electric power	熱負荷 thermal load	進氣口 Gas inlet
燃氣法式燒雞爐 (台式)	MK-FDC22G	1220*670*1350	380V/50Hz/0.2KW	32kW	φ1"(DN25) (可選擇左或右入氣)
燃氣法式燒雞爐 (台式)	MK-FDC32G	1600*670*1350	380V/50Hz/0.2KW	32kW	φ1"(DN25) (可選擇左或右入氣)

電熱系列 Electric Series

產品名稱 Product name	型號 Model	規格(mm) Specification (mm)	耗電量 Power consumption	熱負荷 thermal load
電熱法式燒雞爐 (臺式)	MK-FDC21E	1220*670*1200	380V/50Hz	13.1kW
電熱法式燒雞爐 (臺式)	MK-FDC22E	1220*670*1200	380V/50Hz	17kW
電熱法式燒雞爐 (臺式)	MK-FDC31E	1600*670*1200	380V/50Hz	19.6kW
電熱法式燒雞爐 (臺式)	MK-FDC32E	1600*670*1200	380V/50Hz	25.4kW

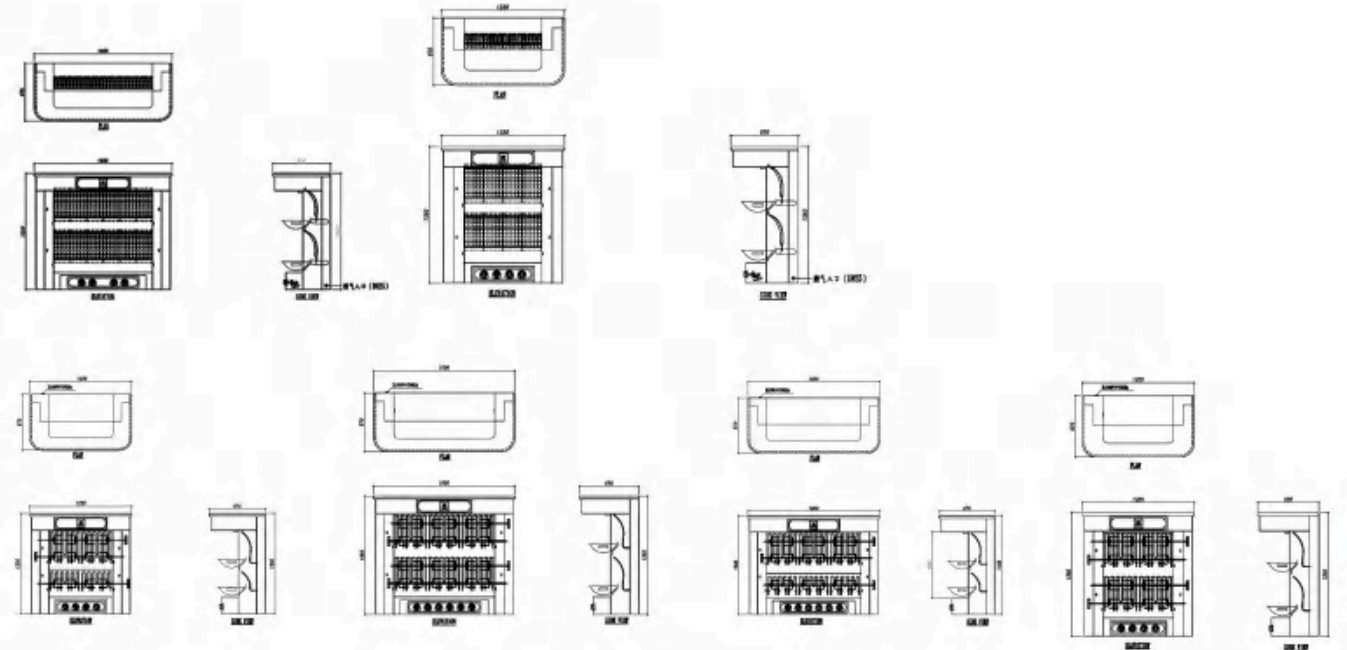

多功能炭熱燒烤箱

MULTI-FUNCTIONAL CHARCOAL OVEN



烧烤炉系列

Grill Series

產品特征 Features

耐火內襯，溫度高達400°C及以上，果木或木炭做熱源，包括多功能燒烤箱，多種規格選擇後部設置燒炭框，多方位加熱；底部設置可調節風門，控制火大小；內壁設置高輻射率耐火材料，提高加熱效率和保溫；前部可收起擋門，使用時放下可做操作平臺；設置開口櫃，可用於放置木炭。配移動輪腳，方便搬運。室內使用需要配備防火排煙罩（運水煙罩）。

Two 300 * 450 barbecue racks are used, and the height can be adjusted to 420. A charcoal burning frame is set at the back for multi-directional heating; Adjustable damper is set at the bottom to control the size of fire; High emissivity refractory is set on the inner wall to improve heating efficiency and thermal insulation; The front door can be retracted, which can be used as an operating platform when in use; An open cabinet is set to place charcoal. Equipped with movable wheel feet for easy handling. Indoor use needs to be equipped with fire and smoke exhaust hood (water fume hood).

炭熱升降燒烤爐 Carbon lifting grill

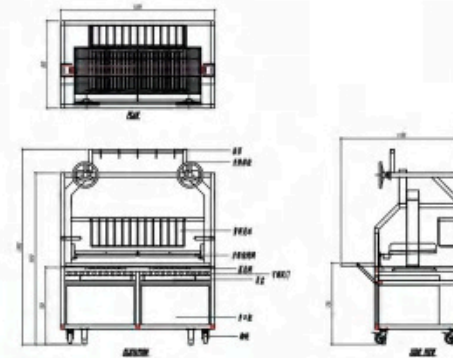

產品名稱 Product name	炭熱升降燒烤爐
型號 Model	CLC-4
規格(mm) Specification (mm)	1500*850*1900
備註 Remarks	

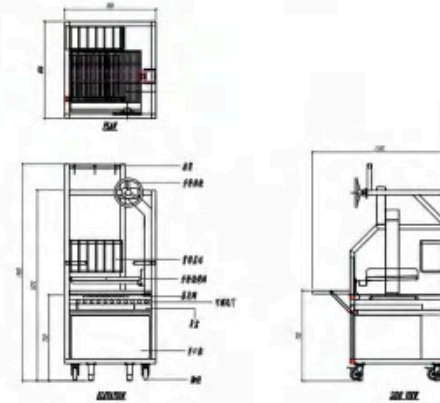

產品名稱 Product name	炭熱升降燒烤爐(右輪)
型號 Model	CLC-2R
規格(mm) Specification (mm)	800*850*1900
備註 Remarks	

產品名稱 Product name	炭熱升降燒烤爐(左輪)
型號 Model	CLC-2L
規格(mm) Specification (mm)	800*850*1900
備註 Remarks	

產品概述PRODUCT OVERVIEW

- 1 烤箱**
機身全304不銹鋼結構，防水、防潮。警告：千萬不要讓火焰的高度超過烤架的高度！
Oven
Completely SS 304 stainless steel structure , water proof and moisture-proof.
Remark : the flame height should be lower than grid height
- 2 燒烤站**
每壹個框架帶兩個可互換的烤架。熱度是由烤架表面高度調節。通過手輪操作
Barbecue device
Each barbecue module frame equipped with two pcs removable grid , the heating temperature control by manual adjust the grid height.
- 3 層架**
在每個燒烤站上都固定帶有休息架，用於擱置物品
Shelf
Each barbecue module equipped with fixed shelf, the shelf used for placed some items.
- 4 燒烤站防火桶**
每個燒烤站都有自己的櫃桶。可以用來擱放額外的燃料（木炭木柴）
Barbecue flame shield
Each barbecue stove has owned flame shield. used for place additional fuel (charcoal or wood)
- 5 抽拉**
每個燒烤站都在底部中嵌入了壹個抽拉灰門。確保灰燼安全地掉進下面的灰門抽屜。滿的時候，灰門可以抽出來，方便排空。
Ash tray
Equipped with drawer type ash tray in the bottom of per BBQ stove ,ensuring the ashes completely dropped in the tray. The tray can be pull-out for clean
- 6 爐膛**
設計是為了給廚師提供盡可能大的烘焙的地方。非常適合鍋具放置或直接燒烤。壹扇下拉門系在壁爐前，關閉時，提供額外的熱保護。當打開門時，可以作為壹個長的操作臺。注意在關上門之前，確保鉸鏈區域幹淨。
Chamber
This designed is provide as much baking space as possible for chefs. and also very suitable for placed cooking pot or roasting directly. Equipped with movable door in front of the chamber , used for provided the heating protection when closed and also as the work table when opened. Please ensure the hinge is clean before close.
- 7 下拉門和工作臺**
下拉門在烤箱升溫或者不使用時，門關閉，使用時門下拉成為操作平臺，用於防止燒烤物品
The sliding door and work table
The sliding door will be closed when heating up process or no running.the sliding door as the work table to prevent over heating food when equipment running.

特征 FEATURE

- 全不銹鋼機身結構，防水、防潮
All stainless steel body structure, waterproof, moisture proof
- 現場安裝可調不銹鋼腳，放置平穩
Adjustable SS feet convenient for install.
- 可以將所有的電氣和燃氣單獨組裝
Independent gas control box and electric control box.
- 單個部件可更換
Replaceable single part
- 安裝和維護成本最低
Lower installation and maintenance costing
- 設計不必要的拐角和接縫易於清潔
Without needless corners and seams design,convenient for clean.
- 嵌入式連接技術
Built-in type connection technology
- 高性能高可靠性
High performance and reliability
- 獨特的安裝橋接和掛鉤設計
Unique installation design and hook design



獨立防火籠
Independent fire cage



燒烤架/燒烤爪
Grill fork



六角棒烹飪組
cooking grid group

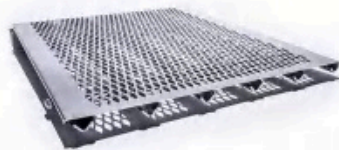

篩分蒸煮表面剖面
sieve net with holder

廚房時代

充分發揮您的創造力

Luxury Household Monoblock Cooking Suite

開放式的空間規劃，清晰的建築軸線，整體廚房設計將烹飪和生活融為壹體，形成了壹個完整構思的生活空間。廚島區域和淺色木板區域完美無縫融合。斜切加工的抽屜式儲物櫃與組合側板優雅地結合在壹起。

作為廚房區域的完美延續，生活空間融合了視覺和功能上的氛圍。由開放式和封閉式櫥櫃以及抽屜插入式分隔的元素巧妙地用作於內部隔板設計：它可以在兩個區域內實現可見的視覺效果，卻不會暗示它們的存在，從而在房間內建立起和諧的融合與交流。

The luxurious household integrated stove integrates commercial elements into the household kitchen, with beautiful layout, compact space, reasonable process, color and shape suitable for the style of household decoration. At the same time, it is necessary to consider the functional equipment and design with low noise, high safety, easy cleaning and maintenance.

The luxurious household integrated stove integrates commercial elements into the household kitchen, with beautiful layout, compact space, reasonable process, color and shape suitable for the style of household decoration. At the same time, it is necessary to consider the functional equipment and design with low noise, high safety, easy cleaning and maintenance.

工程案例-國內 <p>Project Refefences-China Mainland</p>
深圳文華東方酒店Mandarin Oriental, Shenye Uptown
深圳四季酒店 Shenzhen Four Seasons
北京東方君悅酒店 Grand Hyatt Beijing

萬豪國際集團Marriott Hotel management Group
上海雅居樂萬豪酒店 Shanghai Marriott Hotel City Centre
杭州臨安萬豪酒店 Hangzhou Linan Marriott Hotel
北京金融街麗思卡爾頓酒店The Ritz Carlton, Beijing Financial Street
上海奉賢Jw萬豪項目Jw Marriott Hotel, Shanghai
北京金融街威斯汀大酒店 The Westin Beijing
南京湯山園博園威斯汀酒店Westin Nanjing, Nanjing Garden Expo Park
南京微遠格酒店Autograph Collection, Nanjing Garden Expo Park
廣州南沙喜來登酒店 Sheraton Guangzhou Nansha Hotel
深圳大中華喜來登酒店 Sheraton Hotel Shenzhen Futian
綿陽首開喜來登酒店Sheraton Hotel Mianyang Opens For The First Time
廈門艾美酒店Le Méridien Xiamen
杭州浙江世融艾美酒店 Le Meridien Hangzhou Binjiang
北京延慶萬豪酒店Beijing Marriott® Hotel Yanqing

河北秦皇島北戴河萬豪酒店 Marriott Hotel,Beidaihe, Qinhuangdao, HeBei
長沙建鴻達Jw萬豪酒店 Jw Marriott ,Changsha
廣州雲珠萬豪酒店 Marriott Hotel,Guangzhou Yunzhu
上海金橋萬豪酒店Shanghai Marriott Hotel Pudong Eas
三亞萬豪臻品之選酒店 Sanya Marriott Tribute Portfolio
西安高新喜來登酒店Sheraton Hotel , Xi] An Gaoxin
西安浣灤喜來登酒店 Sheraton Hotel , Xi] An Chanba
天津麗思卡爾頓酒店 The Ritz-Carlton,Tianjin
武漢威斯汀酒店 The Westin ,Wuhan
太原Jw萬豪酒店 Jw Marriott, Dayuan

洲際國際酒店集團 Ihg Hotel Management Group
南通濱江洲際酒店 Intercontinental Hotel Nantong
南昌保利皇冠假日酒店 Crowne Plaza,Nanchang
廣州南湖假日 Holiday Inn Guangzhou South Lake
建德千島湖皇冠假日酒店 Crowne Plaza, Jiande Qiandao Lake
深圳華僑城皇冠假日酒店 The Venice Hotel Shenzhen
烏鎮皇冠假日酒店 Crowne Plaza Wuzhen
寶雞皇冠假日酒店 Crowne Plaza Baoji
北京懷柔假日酒店 Holiday Inn Huairou Beijing
青島東方影城萬達皇冠假日酒 Wanda Crowne Plaza Qingdao
香河三田雅泓假日酒店 Holiday Inn Langfang Xianghe
北京西南華邑酒店 Hualuxe Hotels And Resorts
成都千禧洲際皇冠假日酒店 Crowne Plaza Chengdu
杭州奧克斯皇冠假日酒店Crowne Plaza Hangzhou Aux
九寨壩能英迪格酒店 Indigo Jiuzhaigou
南通五洲皇冠假日酒店 Crowne Plaza Nantong Wuzhou
舟山度假皇冠假日酒店 Crowne Plaza Zhoushan Resort
杭州良渚洲際酒店 Intercontinental Hotel Hangzhou Liangzhu

西安浣灤華邑假日酒店 Holiday Inn Xi'An Chanba Hualuxe
騰瑞皇冠假日酒店 Crowne Plaza Tengrui Hotel
河北唐山豐化皇冠假日酒店 Crowne Plaza Tangshan Zunhua, Hebei
廈門集美海泉皇冠假日酒店Crowne Plaza,Xiamen

凱悅酒店集團 Accor Hotel Management Group
成都凱悅酒店 Hyatt Chengdu
桐鄉凱悅酒店 Hyatt Tongxiang
越南芽莊凱悅酒店 Hyatt Regency Nha Trang, Vietnam
廣州增城凱悅酒店Hyatt Regency Zengcheng, Guangzhou
上海松江凱悅酒店 Hyatt Shanghai Songjiang Hotel
寧波凱悅尚萃酒店 Hyatt Centric Ningbo
崇禮凱悅酒店 Hyatt Place Chongli
西安空港凱悅酒店 Hyatt Regency Xi'an Airport
杭州蕭山機場凱悅酒店 Hyatt Hotel Hangzhou Xiaoshan Airport

希爾頓國際酒店集團 Hilton Hotel Management Group
西安灃東希爾頓逸林 Hilton Yilin Xi'An Fengdong
杭州希爾頓嘉悅裏Hilton Hotel Hangzhou
嘉興中港城希爾頓酒店 Hilton Jiaying Zhonggang City Hotel
深圳希爾頓逸林酒店 Hilton Yilin Hotel Shenzhen
廈門佳逸酒店 Joyze Hotel Xiamen
成都百悅希爾頓逸林酒店 Double Tree By Hilton Chengdu
北京通州京杭廣場希爾頓酒店Hilton Beijing Tongzhou Jinhang Plaza Hotel
保利金釘灣希爾頓酒店Doubletree By Hilton Shanwei
青島萬達希爾頓逸林酒店 Hilton Yilin Hotel Qingdao Wanda
九寨溝鲁能希爾頓酒店 Hilton Jiuzhaigou Luneng Hotel
長沙世貿希爾頓酒店Hilton Changsha World Trade Center
上海靜安希爾頓酒店Shanghai Jing 'An Hilton Hotel
西安曲江新區希爾頓嘉悅裏酒店Canopy By Hilton Xi'An Qujiang
蘇州希爾頓逸林酒店 Hilton Yilin Hotel Suzhou
九寨溝康萊德酒店Conrad Jiuzhaigou

卡爾森瑞德酒店集團 Carlson Hotel Management Group
鄭州麗笙酒店 Radisson Hotel Zhengzhou
杭州博地中心鳳瑤酒店 Radisson Hangzhou
蘇州正和麗筠酒店 Radisson Hotel Suzhou
南京園博園麗笙酒店Radisson Blue Hotel, Nanjing Garden Expo Park

君瀾酒店集團 Narada Hotel Group
北京五礦君瀾酒店Wukuang Narada Hotel
青島嶗山壹號院嶗山君瀾酒店Narada Hotel Laoshan Qingdao No.1 Courtyard Laoshan
金華君瀾大飯店(亞達分村) Jinhua Narada Hotel (Yayun Fen Country)

雅高酒店集團 Accor Hotel Management Group
福州泰禾鉅爾曼酒店 Pullman Hotel Fuzhou Taihe
成都索菲特 Sofitel Hotel Chengdu
垂州鉅爾曼 Pullman Huizhou
上海鉅爾曼酒店 Pullman Hotel Shanghai
彌勒雅閣酒店 Maitreya Accord Hotel
溫州臨北新區鉅爾曼酒店 Pullman Hotel Wenzhou Oubel New Area
長沙諾富特酒店 Novotel Changsha
唐山新華聯鉅爾曼酒店 Pullman Hotel Tangshan New Hualian
卓越平湖鉅爾曼項目 Pullman Pinghu
鄭州索菲特國際酒店 Sofitel International Hotel Zhengzhou
北京萬達索菲特酒店 Sofitel Wanda Beijing
長白山鉅爾曼 Pullman Changbai Mountain
西安諾富特酒店 Novotel Xi'An
大理鉅爾曼項目Dali Pullman

學校 Education
北京清華大學Tsinghua University
北京航空航天大學Beijing University Of Aeronautics And Astronautics
中國美術學院良渚校區 China Academy Of Art
西湖大學（雲谷校區）Westlake University(Yungu Campus)
浙江大學
浙江工業大學 Zhejiang University Of Technology
浙江師範大學 Zhejiang Normal University
上海科技大學 Shanghai University
上海食品科技學校 Shanghai Food Technology School
上海中華職業學校Shanghai Zhonghua Vocational And Technical School
深圳南方科技大學Southern University Of Science And Technology
深圳中澳實驗學校Shenzhen Arcadia Grammar School
深圳曼徹斯通國際學校Merchiston Castle School
廣州中山大學東校區East Campus Of Guangzhou Sun Yat Sen University
中山大學深圳校區 Shenzhen Campus Of Sun Yat Sen University
西安交通大學 Xi'An Jiaotong University
南京江寧黨校Nanjing Jiangning Party School

会展、会议中心 Exhibition, Conference Center
北京國家會議中心National Convention Center
長沙北辰三角洲會議中心Changsha Beichen Delta Conference Center
深圳國際會展中心Shenzhen World Exhibition & Convention Center
海南國際會展中心Hainan Convention And Exhibition Center
珠海國際會展中心（二期） Zhuhai International Convention And Exhibition Center (Phase Ii)
廣州市越秀展覽中心 Guangzhou Yuexiu Exhibition Center
深圳福田會展中心Shenzhen Convention&Exhibition Center
青島會展中心 Qingdao Convention And Exhibition Center
廣州廣交會會展中心 Guangzhou Canton Fair Exhibition Center
杭州 G20 峰會會議中心 Hangzhou G20 Convention Center
綿陽科技城-綿陽會議展覽中心 China(Mianyang)Science&Technology City International High Tech Expo
南京揚子江會議中心Nanjing Yangtze River Conference Center
北京市延慶夏都會議中心 Beijing Yanqing Xiadu Convention Center
輝煌國際會議度假區 Brilliant International Conference Resort
壽州國際會議中心Taizhou International Convention Center
西安國際會展中心Xi'An International Conference Center
天津會展中心National Convention And Exhibition Center (Tianjin)
廣州雲珠會議中心 Guangzhou Yunzhu Conference Center
珠海會展中心Zhuhai International Convention&Exhibtion Center

企業單位 Organization
上海谷歌Google Shanghai Staff Canteen
上海市金鯨魚 Golden Arowana,Shanghai
聯想總部 Lenovo Headquarter
深圳中廣核大廈Cgn Group Plaza Shenzhen
深圳華為基地 Huawei Group Shenzhen
寧德時代新能源 Contemporary AmpereX Technology Co., Limited Catl
華為荔枝園員工宿舍 Huawei Litchi Garden Staff Dormitory
江蘇產業研究院Jiangsu Industrial Research Institute
東莞松山湖華為項目 Huawei,Dongguan Songshan Lake
廣汽本田 Gac Honda
廣州香松拉 Xuesongkong,Guangdong
廣州市地鐵線網運營指揮中心 Guangzhou Metro Network Operation Command Center
深圳騰訊科興科學園 Shenzhen Tencent Kexing Science Park
廣州恒大汽車南沙食堂Guangzhou Evergrande Automobile
北京騰訊 Beijing Tencent Staff Canteen
廣州媒體港（騰訊） Guangzhou Media Port (Tencent)
深圳騰訊生態園 Shenzhen Tencent Ecological Park
京東總部2號樓 Jingdong Headquarters Building 2
深圳騰訊 Shenzhen Tencent Staff Canteen
伊利集團上海科技研發中心 Yili Group Shanghai Technology R & D Center
騰訊廣州Tit餐廳Tencent Guangzhou Tit Restaurant
深圳騰訊創益大廈 Shenzhen Tencent Chuangyi Building

政府 Government
中國人民大會堂 Great Hall Of The People Of China
天津管委會 Tianjin Management Committee
中國國家安全局 National Security Bureau Of China
北京城市副中心 Beijing City Sub-Center
阿塞拜疆駐華大使館新建項目 Embassy Of Azerbaijan In China
瀋江政府機關食堂 Binjiang Government Canteen
杭州人民大會堂酒店 Hangzhou Great Hall Hotel
河北雄安商務服務中心 Business Service Center,Hebei Xiongan
中國航發研發總部 China Aviation Development R & D Headquarters

機場航食項目 Airport Aviation Project
深圳機場衛星廳 Shenzhen Airport Satellite Hall
康航成都航食配餐中心Chengdu Eastern Airline Inflight Catering
西南航空成都航食配餐中心Southwest Air Catering Co., Ltd. Tianfubranch
越南富國島機場 Phu Quoc Airport,Vietnam
越南金蘭機場 Cam Ranh Airport,Vietnam
越南諾伯機場 Nuobai Airport,Vietnam

醫院 Hospital
深圳寶荷醫院 Shenzhen Baohe Hospital
南京浦口新城醫療中心 Nanjing Pukou New Town Medical Center
深圳康復醫院 Shenzhen Rehabilitation Hospital
雲南省第一人民醫院The First People] S Hospital Of Yunnan Province
合肥京東方醫院 Hefei Boe Hospital
無錫凱宜醫院 Wuxi Kaiyi Hospital
青島東方影都國際醫院 Qingdao Oriental Film Capital International Hospital
南京鼓樓醫院Nanjing Drum Tower Hospital
深圳禾正醫院Shenzhen Hyzen Hospatal
廣州南沙醫院 Guangzhou Nansha Hospital

銀行Bank
佛山滙豐銀行 Hsbc Bank Foshan
中信銀行大廈China Citic Bank Plaza
山東農業銀行 Agricultural Bank , Shandong
福州興業銀行 Industrial Bank,Fuzhou
深圳微眾銀行1 Wezhong Bank Shenzhen
重慶工商銀行 Industrial And Commercial Bank ,Chongqing
北京亞洲基礎設施投資銀行總部Beijing Asian Infrastructure Investment Bank Headquarters
北京工商銀行icbc Beijing Branch
南京交通控股中心 Nanjing Transportation Holding Center
海南銀行 Bank Of Hainan
湖南投資大廈（交通銀行） Hunan Investment Building (Bank Of Communications)
深圳中興銀行 Shenzhen Zte Bank
北京人民銀行項目 People’S Bank Of Beijing
慶城農商銀行 Lucheng Rural Commercial Bank
長沙招商銀行 China Merchants Bank,Changsha
南京浦發銀行 Pudong Development Bank,Nanjing
上海浦發銀行Shanghai Pudong Development Bank

工程案例-国外 <p>Project Refefences-Overseas Market</p>
馬來西亞吉隆坡貴都大酒店 Hotel Equatorial Kuala Lumpur, Malaysia
印尼日惹萬豪 Marriott Yogya, Indonesia
馬六甲馬六甲萬怡酒店 Marriott Courtyard Malacca, Malaysia
孟加拉喜來登 4 Point Sheraton, Bangladesh
印尼騰笙梳撻酒店 Radisson Lampung, Indonesia
越南胡志明泰菲特酒店 Sofitel Ho Chi Minh,Vietnam
孟加拉長灘酒店 Long Beach Hotel, Bangladesh
巴厘島四季酒店 Four Seasons Bali
馬來西亞吉隆坡市中心鉅爾曼 Pullman Klcc, Malaysia
越南富國島萬豪酒店 Jw Marriott Phu Quoc, Vietnam
沙特阿拉伯夏爾馬酒店Sharma Complex, Saudi Arabia
越南芽莊凱悅酒店 Hyatt Regency Nha Trang, Vietnam
越南佩裏多惠酒店(Delano) Pr 2490 Peridot Hin Hotel (Delano) Pr 2490, Vietnam
緬甸薩爾溫江大酒店 Yangon Thanlwin Hotel, Myanmar
馬來西亞迪沙魯安納塔拉酒店 Anantara Desaru , Malaysia
菲律賓威斯汀索納塔 Westin Sonata, Philippine
馬來西亞檳城希爾頓酒店 Malaysia Penang Hilton, Malaysia
緬甸泛太平洋酒店 Pan Pacific Hotel Yangon,Myanmar
臺灣桃園喜來登酒店 Taiwan Taoyuan Sheraton
越南富國島鉅爾曼酒店 Pullman Phu Quoc, Vietnam
泰國曼谷凱賓斯基酒店 Sindhorn Kempinski, Thailand
沙巴國際會議中心 Sabah International Convention Center(Sicc) Malaysia
馬來西亞莎蘭逸林希爾頓 Doubletree By Hilton, Malaysia