



bulk installation

SHEBEL[®]line

LAVORGOMMA[®]
LAVORGOMMA GROUP



INDICE

Storage standard belts	p 4
Installation standard belts	p 6
Types of splices textile belts	p 7
Mechanical fasteners	p 8
Splicing of textile belts by cold vulcanization	p 9
Splicing of textile belts by hot vulcanization	p 14
Splicing of steel cord belts by hot vulcanization	p 18
Take up travel	p 24
Storage belts with sidewalls and cleats	p 26
Installation belts with sidewalls and cleats	p 28
Example of deflection pulley	p 29
Errors in belt usage	p 30
Sidewalls and cleats on site application	p 33

STORAGE STANDARD BELTS

Conveyor belting is frequently stored either as replacement belting or whilst awaiting completion of an installation under construction.

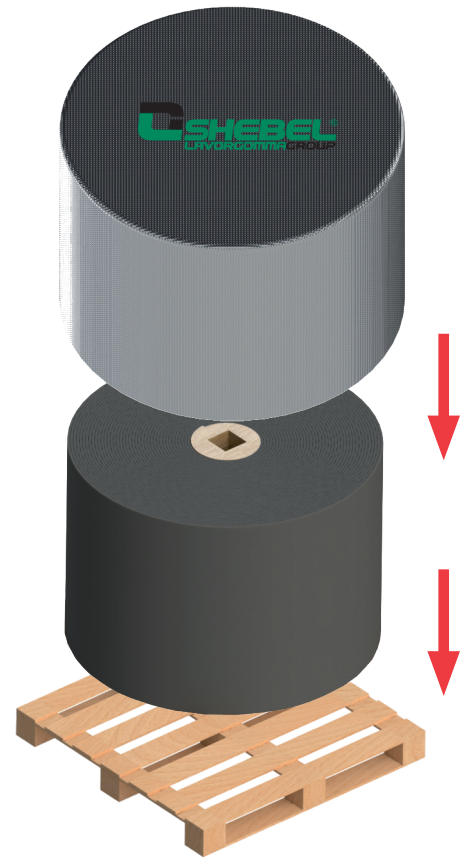

Storage conditions should be carefully monitored in order to prevent deterioration of the physical properties of the belt, which may adversely affect its subsequent service life.

The storage area should be dark and dry in ambient temperatures between 0°C and 20°C.

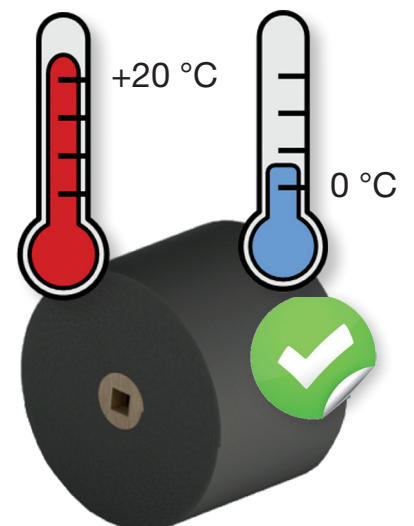
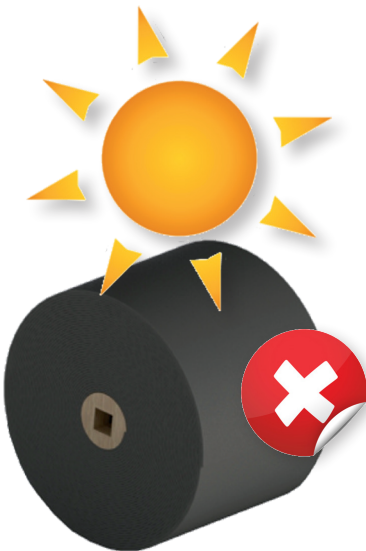

Mechanical damage and contact with oils, greases, petrol or chemicals should be avoided. If outdoor storage cannot be avoided, the belt should be adequately protected (possibly covered) against direct sunlight and extremely high or low temperatures.



Location for storage.

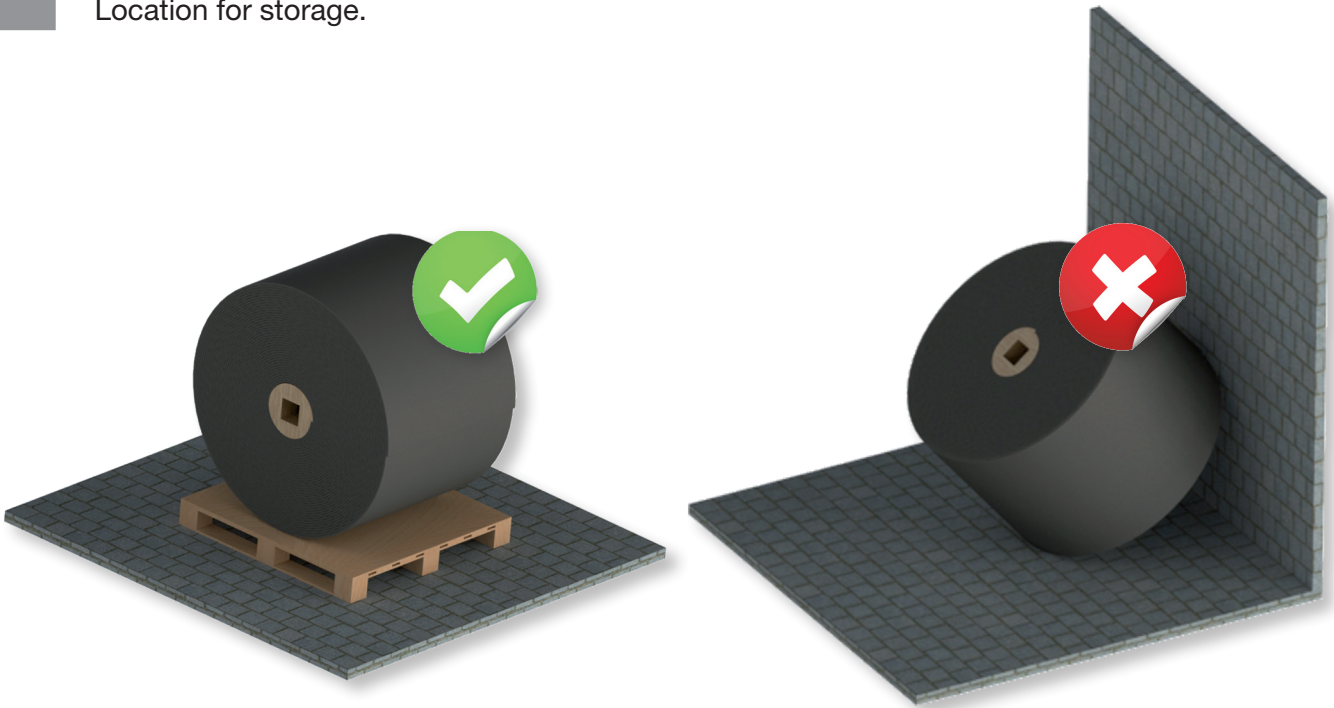

If the storage lasts more than 90 days, the belt shall be handled to alternate the folds.

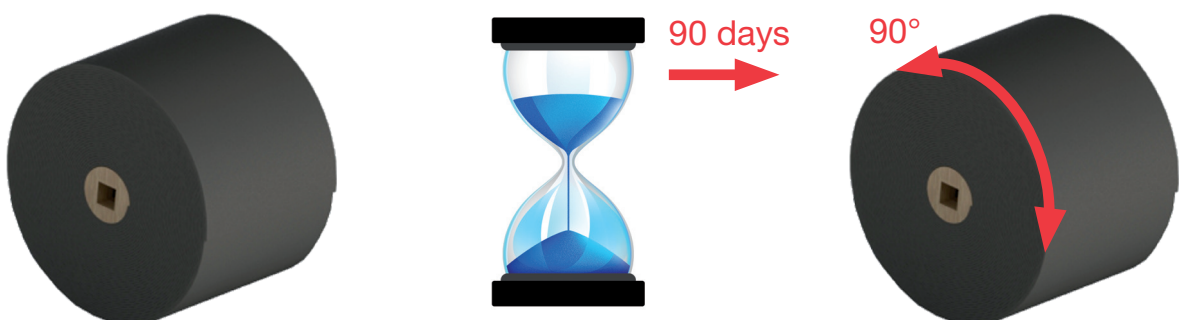



INSTALLATION STANDARD BELTS

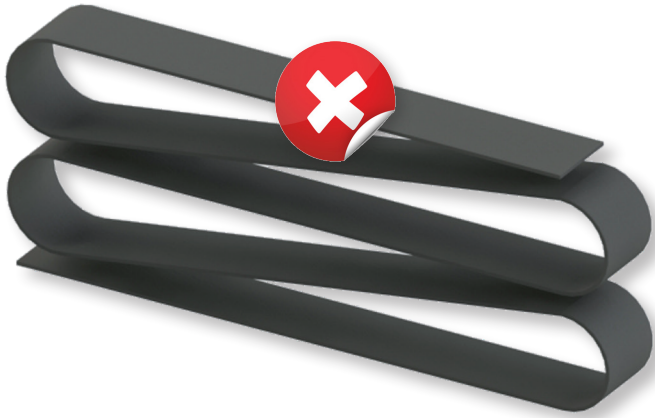



TYPES OF SPLICES TEXTILE BELTS



Fasteners mechanical



Cold vulcanized splices



Hot vulcanized splices





MECHANICAL FASTENERS

WARNING !

The choice of the fastener depends on the belt strength, belt thickness and pulleys diameter

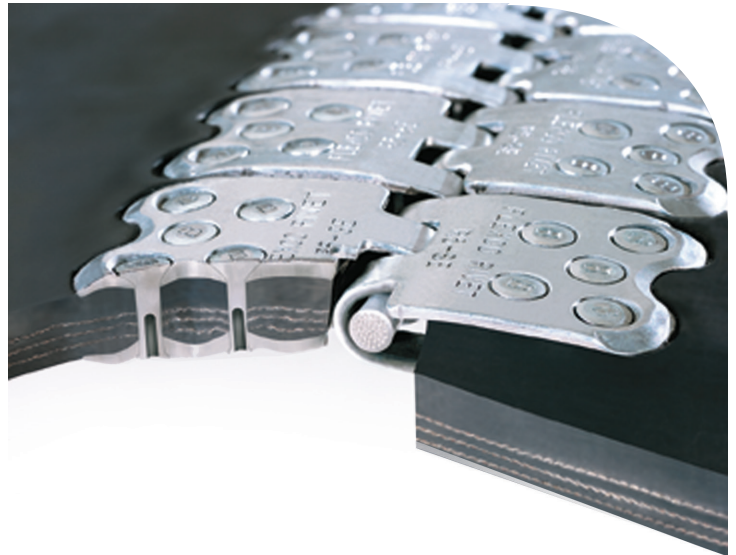



SPLICING OF TEXTILE BELTS BY COLD VULCANIZATION

Belt type	N° of steps	Strength of the fabric	Step length	Splicing length
		N/mm	mm	mm
EP 315/3	2	80 to 100	180	360
EP 400/3	2	125 to 160	240	480
EP 500/3	2	125 to 160	240	480
EP 630/4	3	125 to 160	240	720
EP 800/4	3	200 to 250	300	900
EP 1000/5	4	200 to 250	300	1200
EP 1250/5	4	200 to 250	300	1200
EP 1600/5	4	315 to 400	360	1440
EP 2000/5	4	315 to 400	360	1440
EP 2500/5	4	500 to 630	420	1680
EP 3150/5	4	500 to 630	420	1680

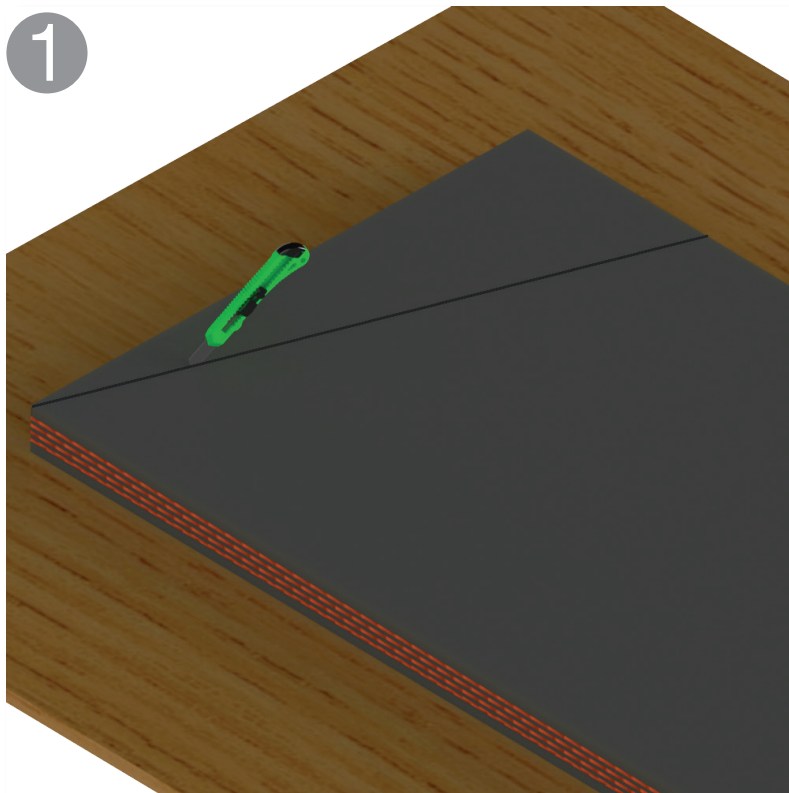

Belt ends are cut as angular shape. Belt width multiplied by factor passing smaller pulleys, narrower angles are recommended.

2

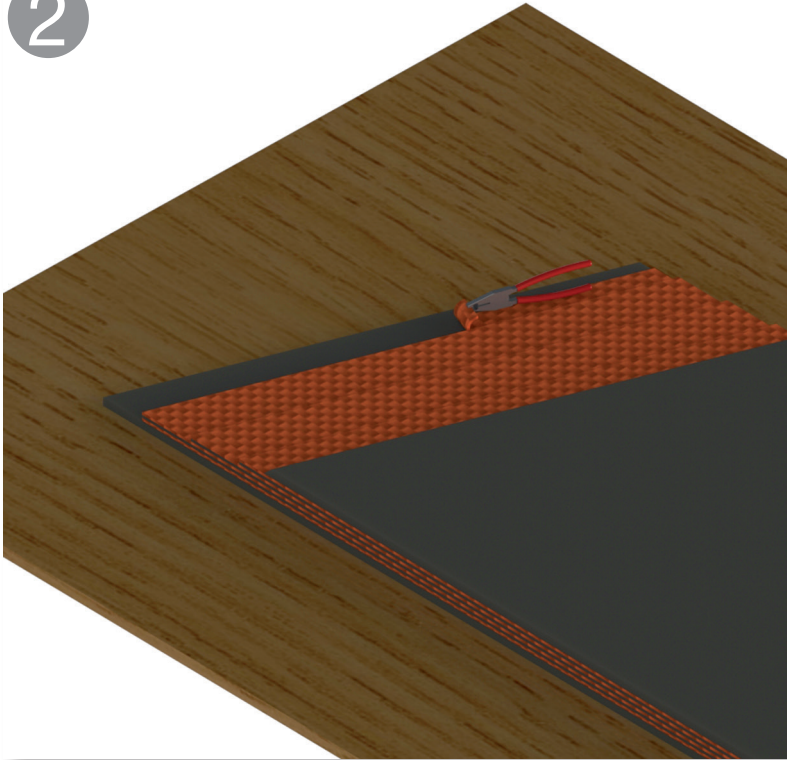

Fabric are opened at lengths specified in the chart as per fabric resistance. Cover is removed from 30 mm inwards of the utmost fabric layer. Similarly, lowest fabric is removed leaving 50 mm bottom cover.

3

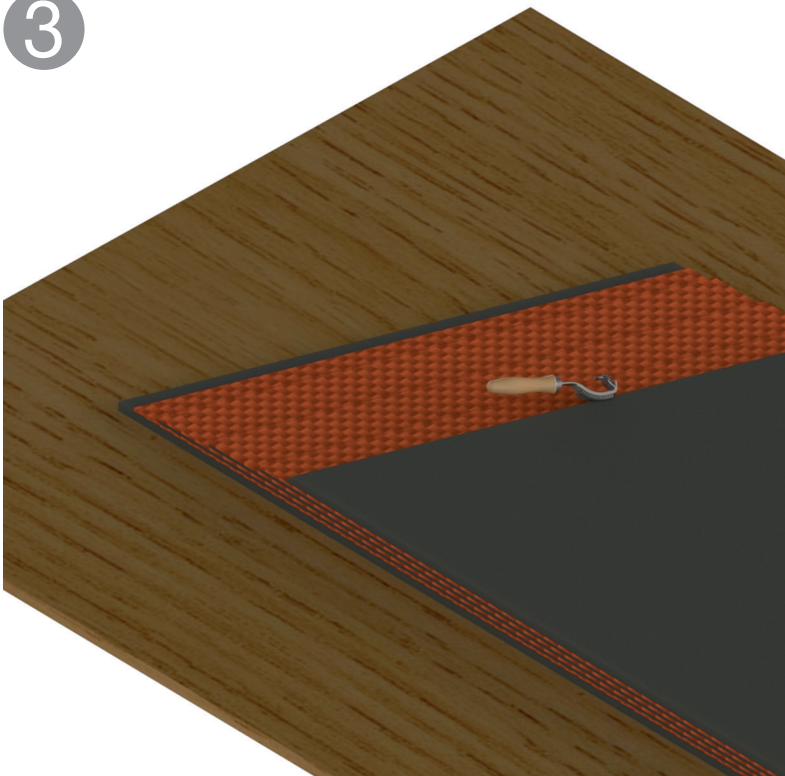

Sharp edge, where top cover and fabric overlaps, is abraded at an angle of 45° with brush or spiral abrasive.

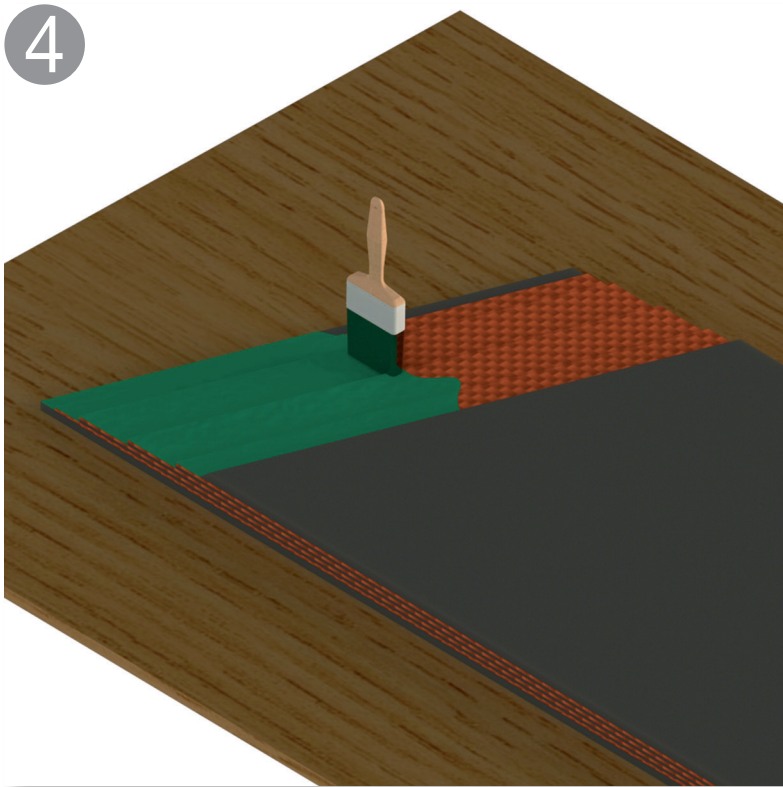

Cold vulcanized adhesive mixed with hardener is applied both surfaces prepared for splicing. Adhesive should be provided to penetrate thoroughly into the fabric. While the compound is applied, brush should be pressed towards rotation powerfully and a homogeneous layer should be formed on splicing surfaces. Compound should be well distributed. Otherwise air bubbles to be formed would not dry completely. Each Splicing when system does not incorporate scraper. layer to be applied should be dried thoroughly. Duration might change depending on climate conditions. For waiting times refer to gluing solution data sheet. It's not recommended to use an instrument like rays or fans in drying out process.

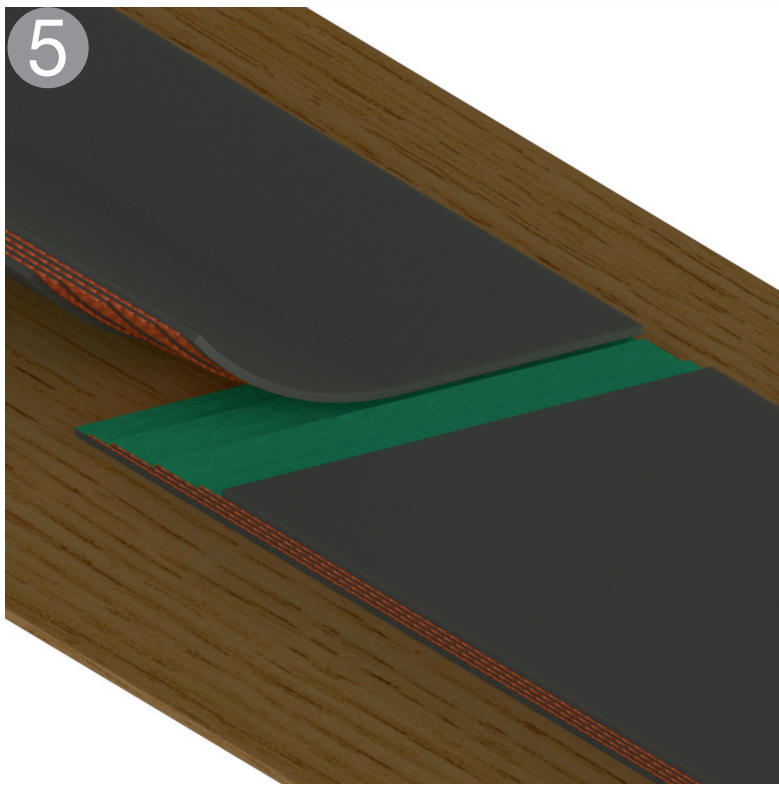

To provide synchronized drying of both parts of splicing, it is recommended that the last layer must be applied on both parts at the same time by two assemblers. Rubber surfaces dry more quickly than adhesive applied fabric surfaces. For this reason, a tiny layer should be applied to these parts before the last fabric layer dries. Great care is required in gathering two belts and all the steps should be coincided together. Gathering should be done carefully. Because in contrary to the hot vulcanization, subsequent adjustment is not possible. Otherwise adhesion film which is extremely important for adhesion will be damaged. In case of gathering is regular for any reason and removal is required, a thin layer of compound should be applied again and waited for drying.

6

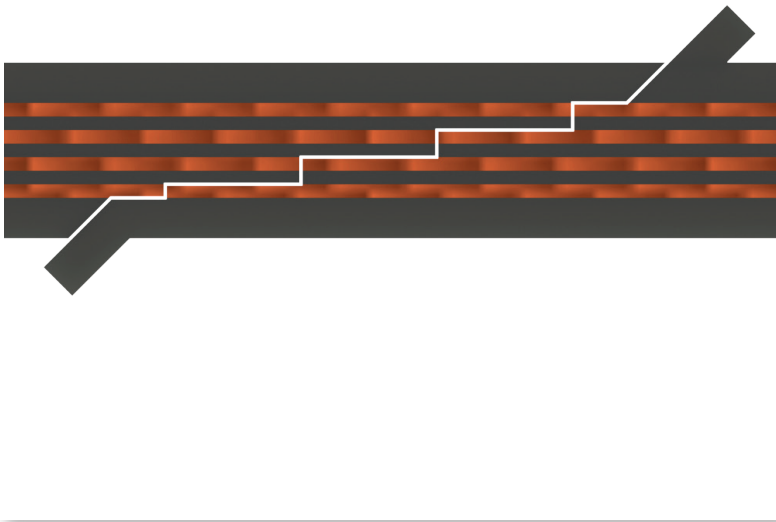

Rubber projections are formed on top and bottom surfaces as shown in the figure.

7

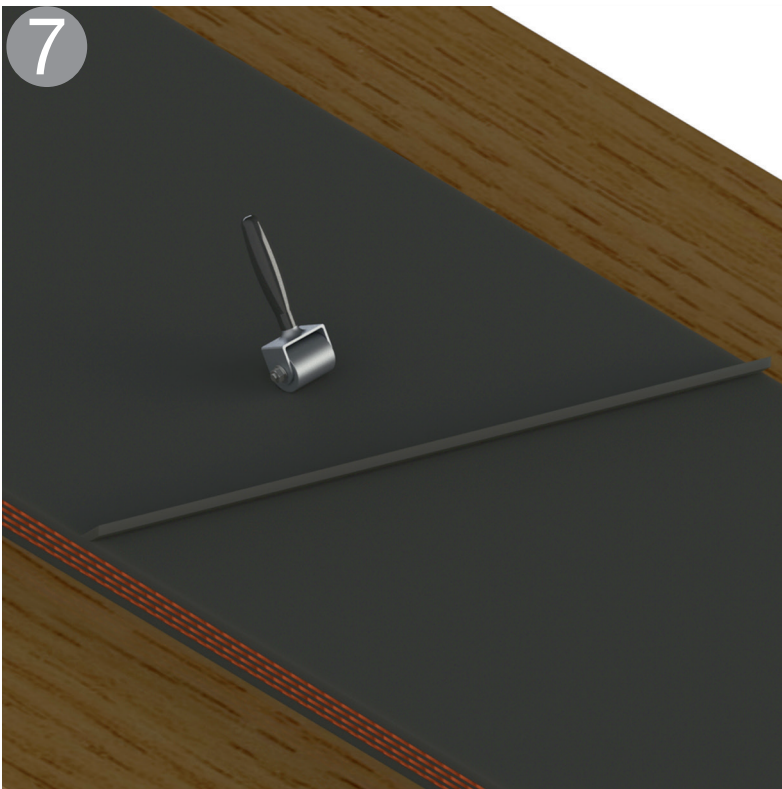

Adhered parts should be pressed by using a roller. Roller should be directed from center to the edges (Removing air from the edges.)

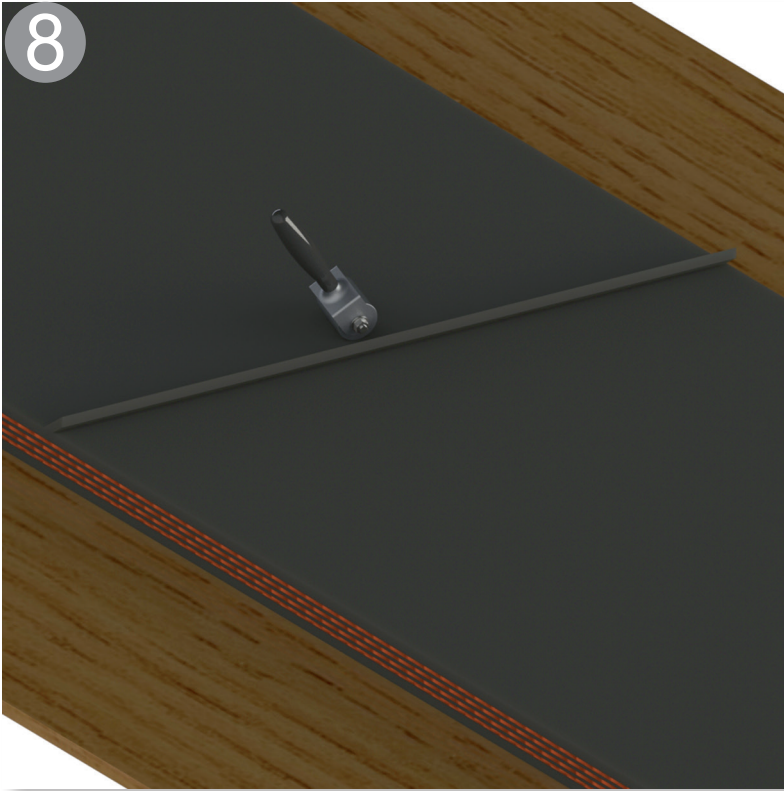

Subsequently joint juncture place is pressed morepowerfully along the juncture place with a roller.

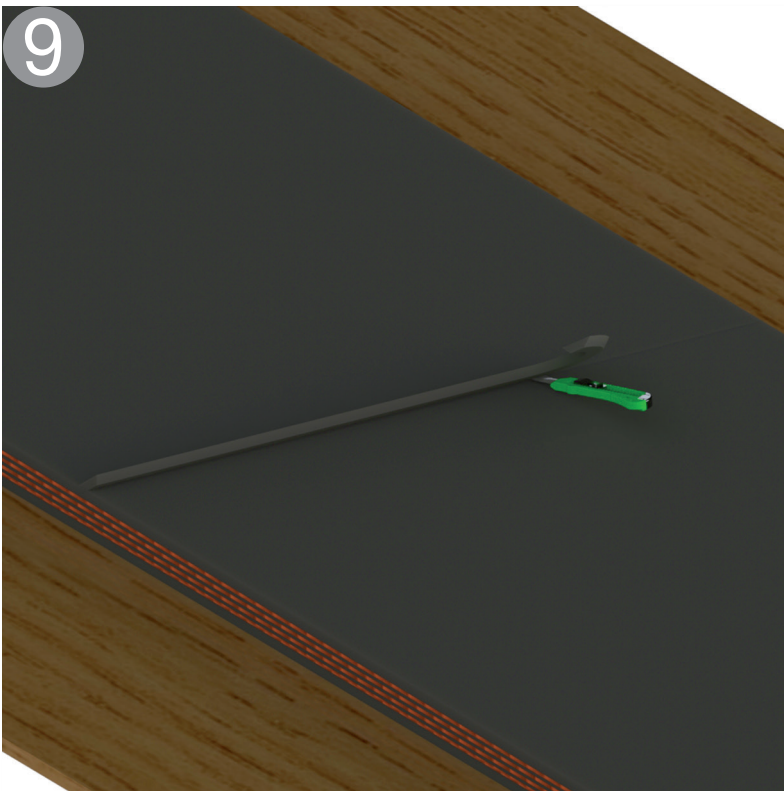

Then excess rubbers are cut carefully using a sharp knife. If any pores are observed, a paste formed by mixing rubber dust and cold adhesive is applied and filled. A better result is obtained in adhesion by placing a heavy object onto the joint place until belt is operated for service. Adhesion power increases in time. Belt should not be operated before times indicated in gluing solution data sheet.



SPLICING OF TEXTILE BELTS BY HOT VULCANIZATION



Drawing of the central line and base line

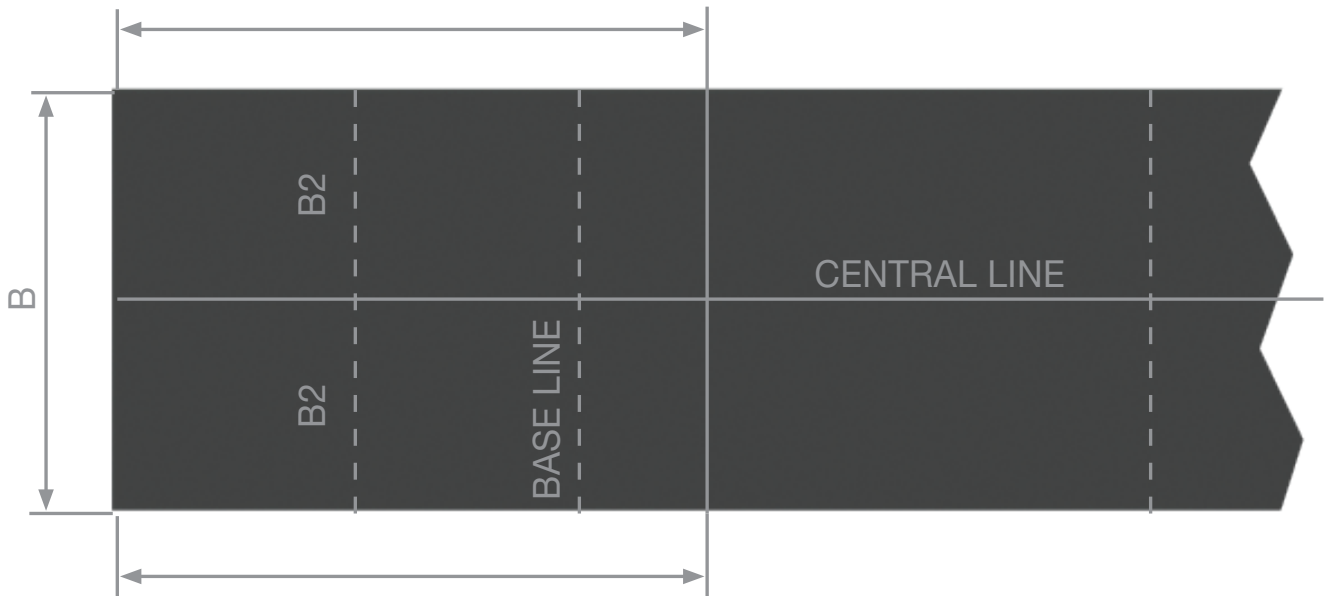

Centre line:

First mark the centre line of the belt by measuring the midpoint of the belt width at a minimum of three stations and join these points together. Using a square, mark off a base line at right angles to the centre line. This centre line is used at a later stage to align the splice with help of a string or a chalk line. This centre line must be at right angles to the base line.

Base line:

Draw a perpendicular line from the centre line of the belt with a square



Preparation of the splice

First of all the required bias line of the splice has to be marked. For all belt types this bias is equivalent to 0.3 times the belt width

Belt width	Bias
mm	mm
400	120
500	150
650	195
800	240
1000	300
1200	360
1400	420

All steps should be made in accordance with this bias (0.3 x B)

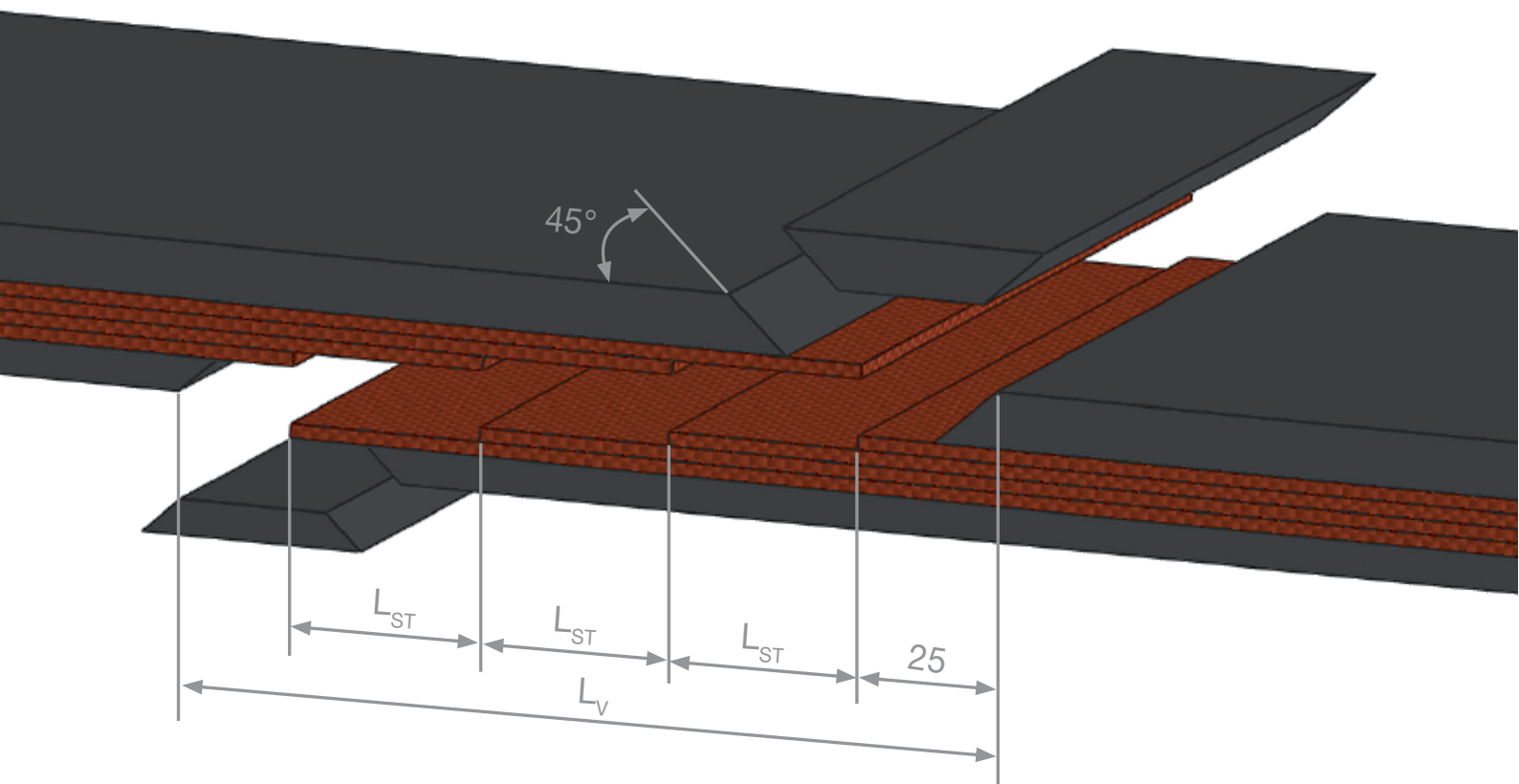
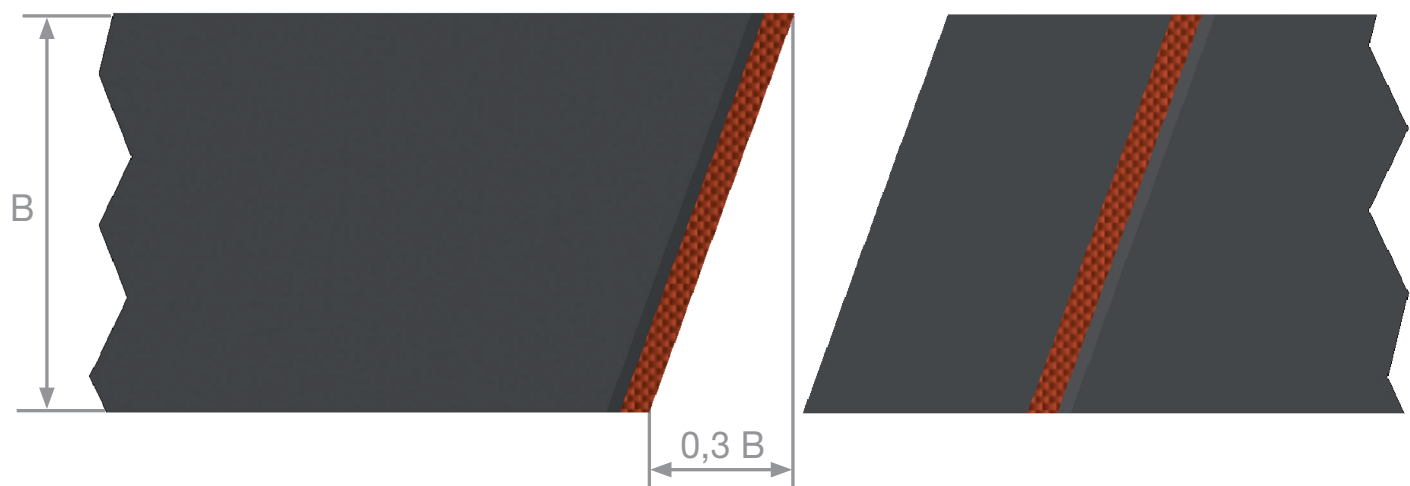

According to the standard DIN 22102

Belt type	N° of steps	Strength of the fabric	Step length L_{ST}	Splicing length L_V
		N/mm	mm	mm
EP 315/3	2	80 to 100	150	300
EP 400/3	2	125 to 160	200	400
EP 500/3	2	125 to 160	200	400
EP 630/4	3	125 to 160	200	600
EP 800/4	3	200 to 250	250	750
EP 1000/5	4	200 to 250	250	1000
EP 1250/5	4	200 to 250	250	1000
EP 1600/5	4	315 to 400	300	1200
EP 2000/5	4	315 to 400	300	1200
EP 2500/5	4	500 to 630	350	1400
EP 3150/5	4	500 to 630	350	1400

Splicing execution

Once the steps have been marked off, the preparation may begin. A strip of cover rubber, 25-30 mm wide, is removed across the full width of the belt. In order that a good bond strength is being obtained between the existing cover and the insertion strip, the cover should be chamfered to an angle of approx. 45° (see figure 2). The splice steps should subsequently be prepared as illustrated in figure 2.

If the layers of fabric cannot be removed in one piece, it is recommended that they be removed in strips. The strips should always be cut in the longitudinal direction and not in the transverse direction. If by accident transverse cuts are made in underlying plies this will have an adverse effect on the strength of the splice. Residue of the skim rubber should be removed as far as possible.

WARNING !

Buffing of the fabric steps should be avoided because this can cause severe damage to the fabric and result in a weakened splice !

Bulding the splice

Apply two coats of solution to both stepped down ends (waiting at least 10 minutes after the first application). Allow the solution to dry and then apply a layer of skim rubber to the steps of one belt end. The skim must cover the whole splice area and should be rolled down in such a way that no air is trapped between it and the underlying splice steps. The skim is then coated with solution (a single coat) and is allowed to dry. It is important that the splice area stays free from dust and humidity. Avoid contact with the splice area after it has been coated with solution.

Lay out the belt end prepared with skim gum and fit the other end to it. When matching the two ends together it is advisable to leave the protective backing supplied with the carcass skim gum so that the surfaces do not adhere. Make sure that the splice is properly aligned and that the fabric steps do not overlap at any point. It is equally important not to leave gaps between the steps and that there is no twist in the belt.

Apply a thin coat of solution to the rubber edges and the carcass at the cover channel. Then apply a strip of skim rubber and fill the gap with cover rubber. This insertion should be approx. 0.5 mm thicker than the belt in order to obtain sufficient pressure during curing.

Note: Do not use the 0.5 mm skim rubber between the original cover rubber and the uncured rubber, since the bond between these two will not be of the same high level.

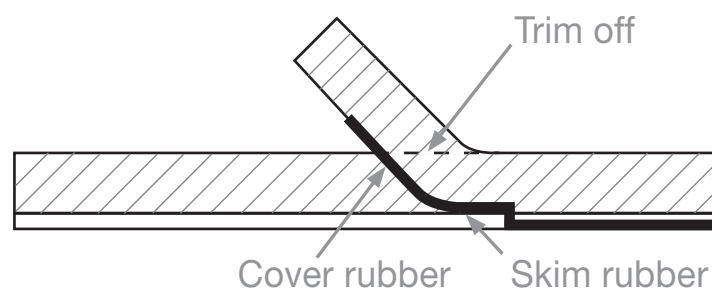

After preparation as described above the belt is ready for vulcanization. The belt is retained at the edges by means of iron edge bars. These must be 0,5 mm – 1 mm thinner than the original belt.



Vulcanization

With the mechanical pressure vulcanizer, tightening should be uniform and in stages using a torque spanner according to the press manufacturers recommendations.

With hydraulic and pneumatic type presses the pressure must be built up slowly. During vulcanization the pressure must be approx. 70 N/sq.cm (7 Bar). Throughout the entire vulcanizing time the pressure must be constant. It may sometimes be necessary to cure the full splice length in more than one charge. In such cases care should be taken to see to it that the channels are vulcanized always in one single cure. Also ensure that the ends of the splice are at least 75 mm inside the platens of the vulcanizer and that an adequate overlap of 75 mm exist between two consecutive charges.



Temperature and vulcanization time

The vulcanization temperature is between 150°C and 155°C. If the press platens are not provided with a thermostat the temperature should be maintained between 150°C and 155°C by switching the power supply on and off.

The vulcanization time starts when a temperature of 150°C is reached.

For belts having a thickness lower than 10 mm the vulcanization time is 20 minutes; for higher thickness add 1 minute every millimeter.

When the splice has been vulcanized for the recommended time the power supply should be switched off.

The press must cool down while still under pressure!

When the press platens have cooled down to a temperature of 80°C or less, the pressure may be reduced slowly. After this the press can be dismantled.

Finish the edges of the belt removing by means of a cutter the rubber in excess.

SPLICING OF STEEL CORD BELTS BY HOT VULCANIZATION

Flinger splice

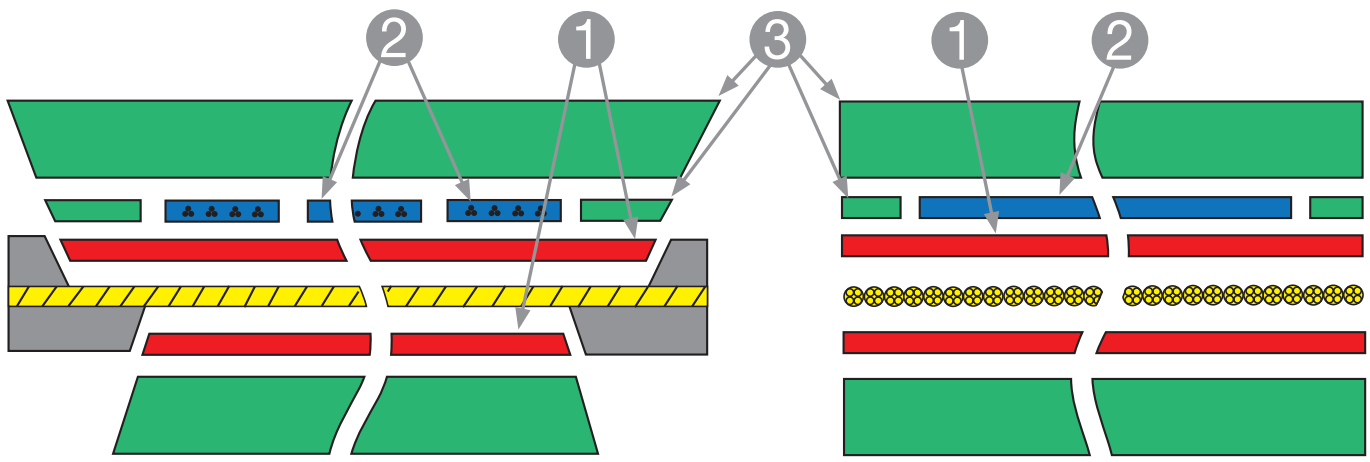
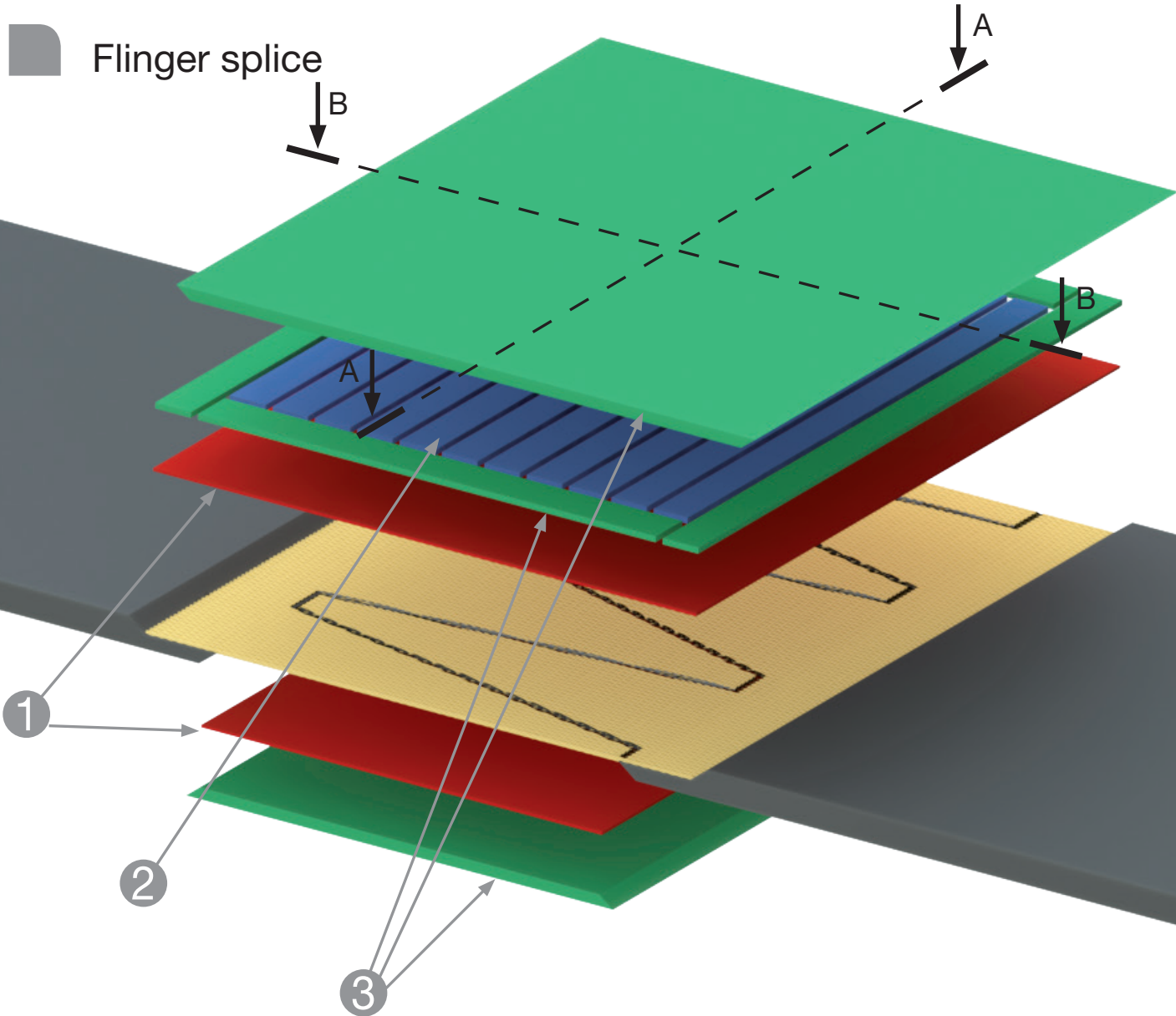

SEZIONE A-A

SEZIONE B-B

- ① Skin coast
- ② Insertion Strip
- ③ Cover-filler compound

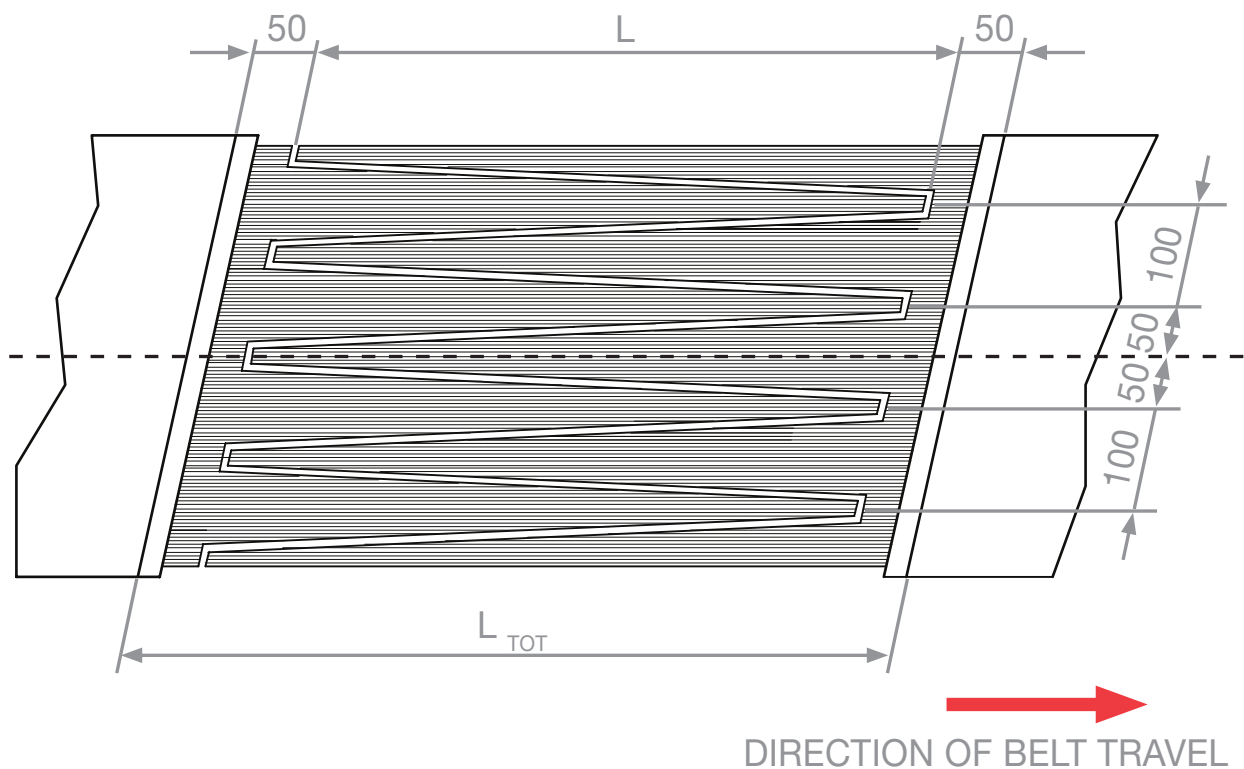

WARNING !

The splice length can be made 20% shorter if insertion strips IS 630 are used transverse wise in top and bottom cover

Class	L	L_{TOT}
KN/m	mm	mm
350	350	450
500	500	600
630	630	730
800	800	900
1000	1000	1100
1250	1250	1350
1400	1400	1500
1600	1600	1700
1800	1800	1900
200	2000	2100
2250	2250	2350

ATTENTION !

It is' absolutely essential that all layers making up the splice are carefully solutioned and let dry before the application; if this is not executed, air bubbles may result on the surface during the vulcanization, making the product quality and mechanical resistance worse.

Steel rope splice

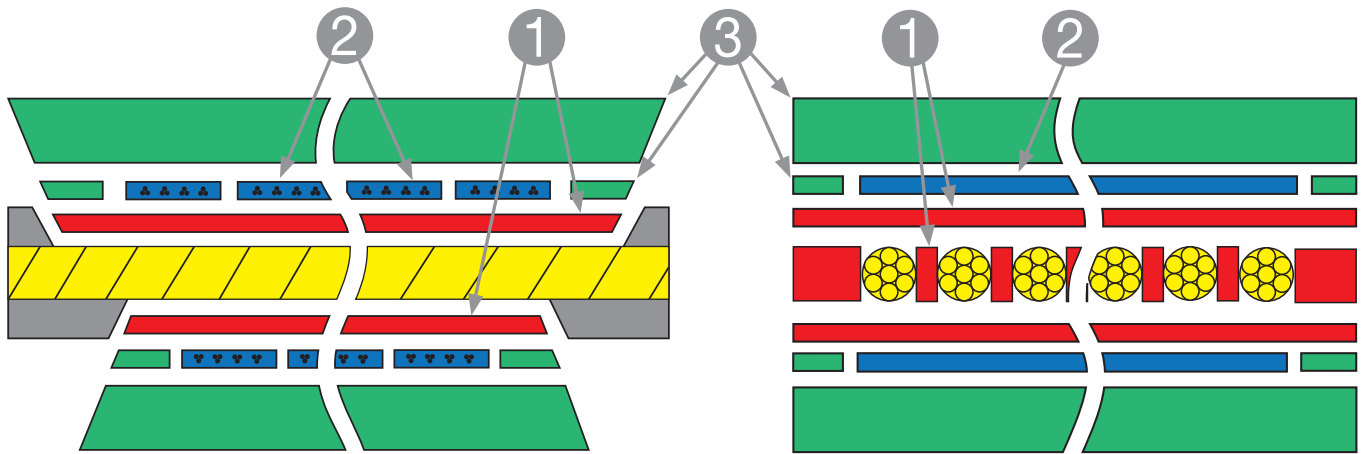
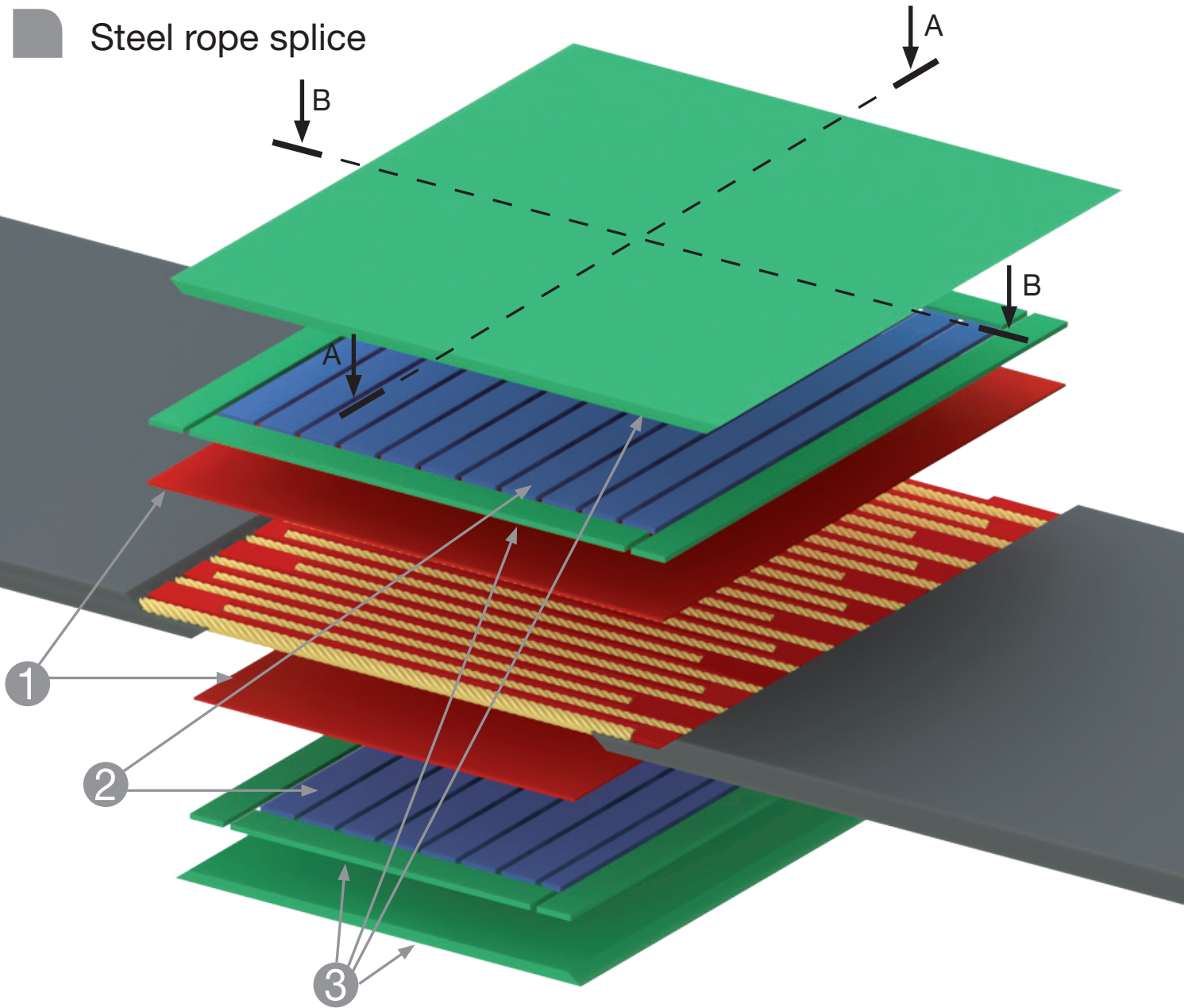

SEZIONE A-A

SEZIONE B-B

① Skim coat

② Insertion Strip

③ Cover-filler compound

One-step splice

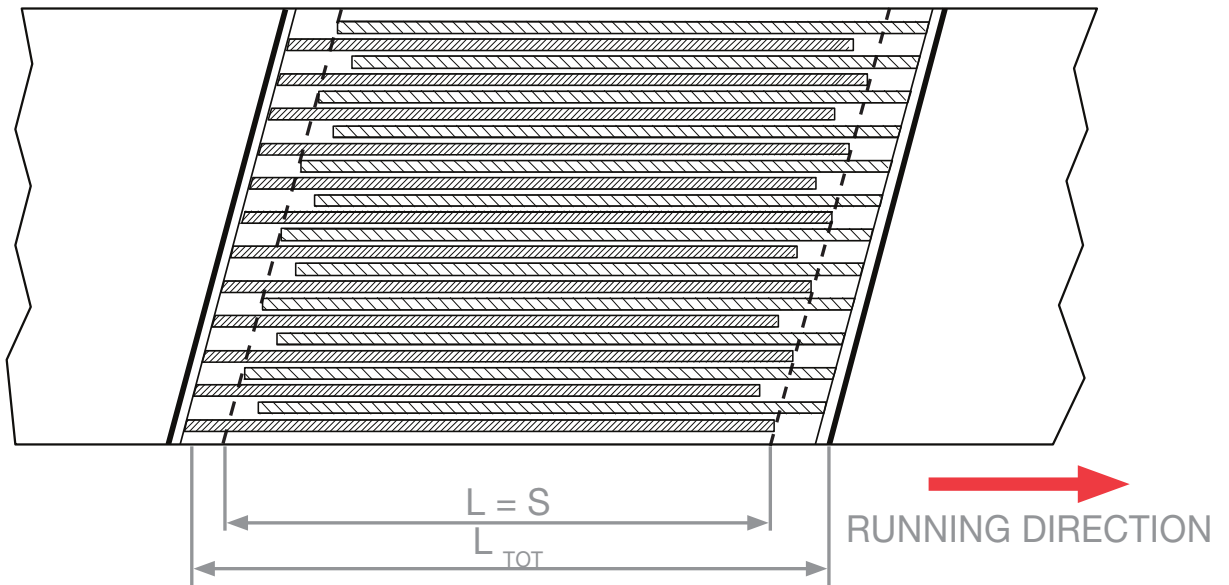

Two-step splice

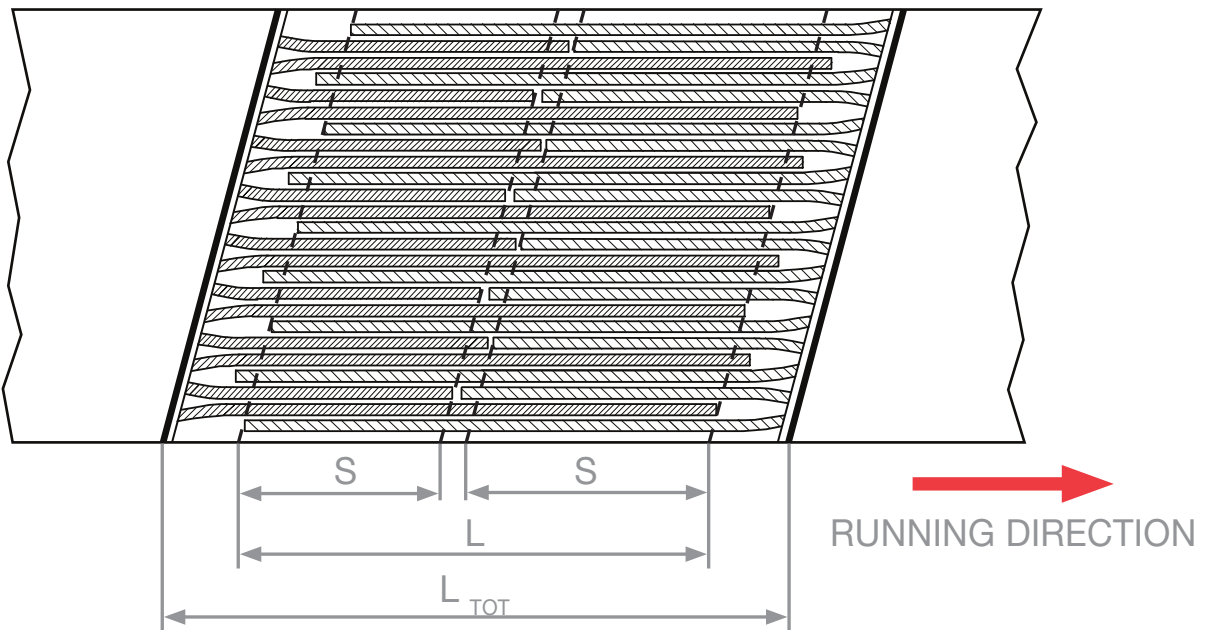

	Class	L	L_{TOT}	S
	KN/m	mm	mm	mm
ONE-STEP SPLICE	500	250	450	250
	630	250	500	250
	800	250	550	250
	100	300	600	300
	1250	350	650	350
	1400	400	700	400
	1600	450	750	450
TWO-STEP SPLICE	1800	750	1050	350
	2000	850	1150	400
	2500	1050	1350	500
	3150	1350	1650	650

ATTENTION !

It is' absolutely essential that all layers making up the splice are carefully solutioned and let dry before the application; if this is not executed, air bubbles may result on the surface during the vulcanization, making the product quality and mechanical resistance worse.

Raw materials

Indispensable components for making joints are:

Hot splicing solution



Cable adhesion skim coat ,
thickness 0,5 or 1 mm



Insertion strip

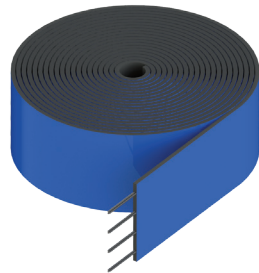

Cover rubber
supplied in various quality (abrasion resistant, heat resistant, oil resistant selfextinguish, etc.) and in various thicknesses (from 2 to 5 mm)

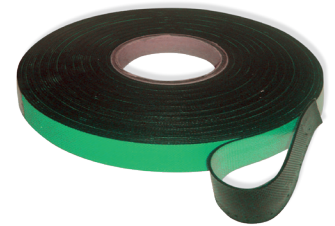

Storage of the raw materials

The raw materials are packed and sealed in cases if they are liquid or in carton boxes if they are solid.

the standard packages report the packing date and the period of validity according to the un-dermentioned conditions and shall be applied for the transport by road only.

In case of transport by sea or by air it will be necessary to produce special protecting packages according to the regulations in force.



All the raw materials for the splicing shall be stored as follows:

Packed and sealed in the original packages.



Room temperature between 5 and 20°C (70°F)

Places shielded from atmospheric agents and which are not subject to extreme conditions.

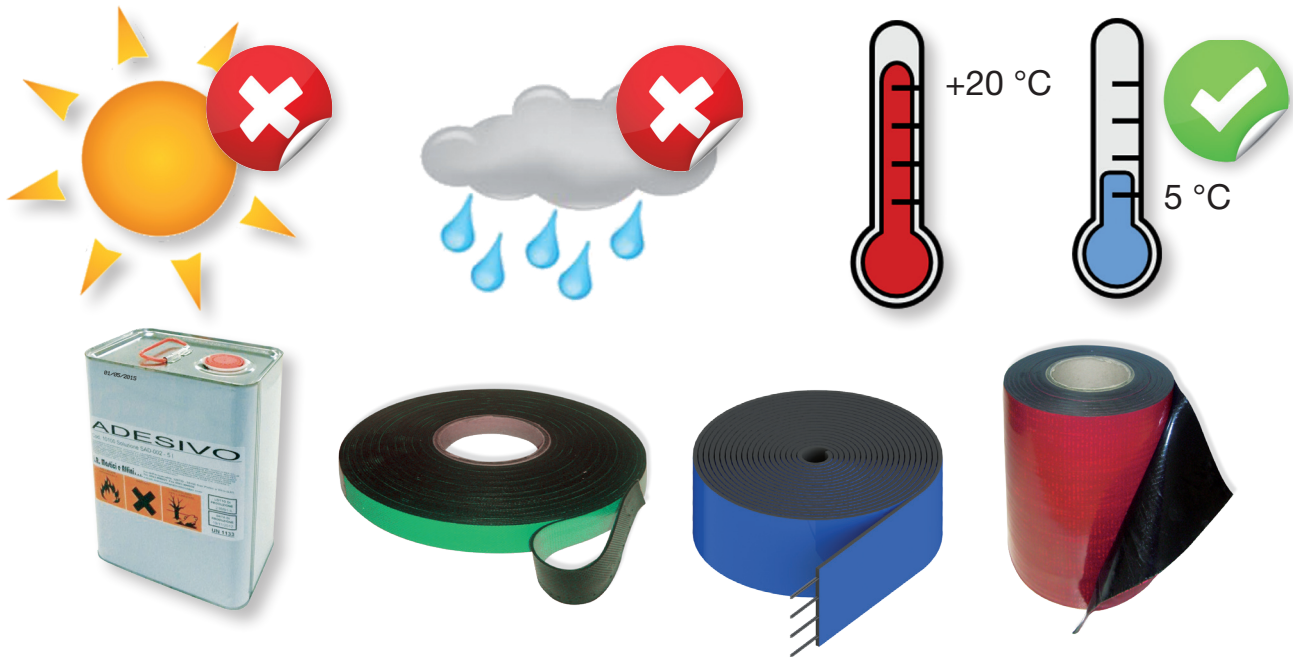

Reccomendations

The period of validity means the life period at the conditions above mentioned. After a partial use, the products shall be hermetically sealed and/or packed as at the beginning. Shebel s.r.l refuses all responsibility for possible alterations suffered by the products during the transport , for the use of the material already expired or packed without respecting the previous conditions.

Vulcanization

For steel cord belts may be used an hydraulic or pneumatic wich reach a pressure of 10-12 Kg/cmq. The pressure must be built up slowly. During vulcanization the pressure must be constant throughout the entire vulcanizing time. Steel cord belts must be vulcanized always in one single cure so use a press with adequate dimensions.

Temperature and vulcanization time

The vulcanization temperature is between 150°C and 155°C. If the press platens are not provided with a thermostat the temperature should be maintained between 150°C and 155°C by switching the power supply on and off. The vulcanization time starts when a temperature of 150°C is reached. For belts having a thickness lower than 10 mm the vulcanization time is 25 minutes; for higher thickness add 1 minute every millimeter. When the splice has been vulcanized for the recommended time the power supply should be switched off. The press must cool down while still under pressure !

When the press platens have cooled down to a temperature of 70°C or less, the pressure may be reduced slowly. After this the press can be dismantled. Finish the edges of the belt removing by means of a cutter the rubber in excess.



TAKE UP TRAVEL

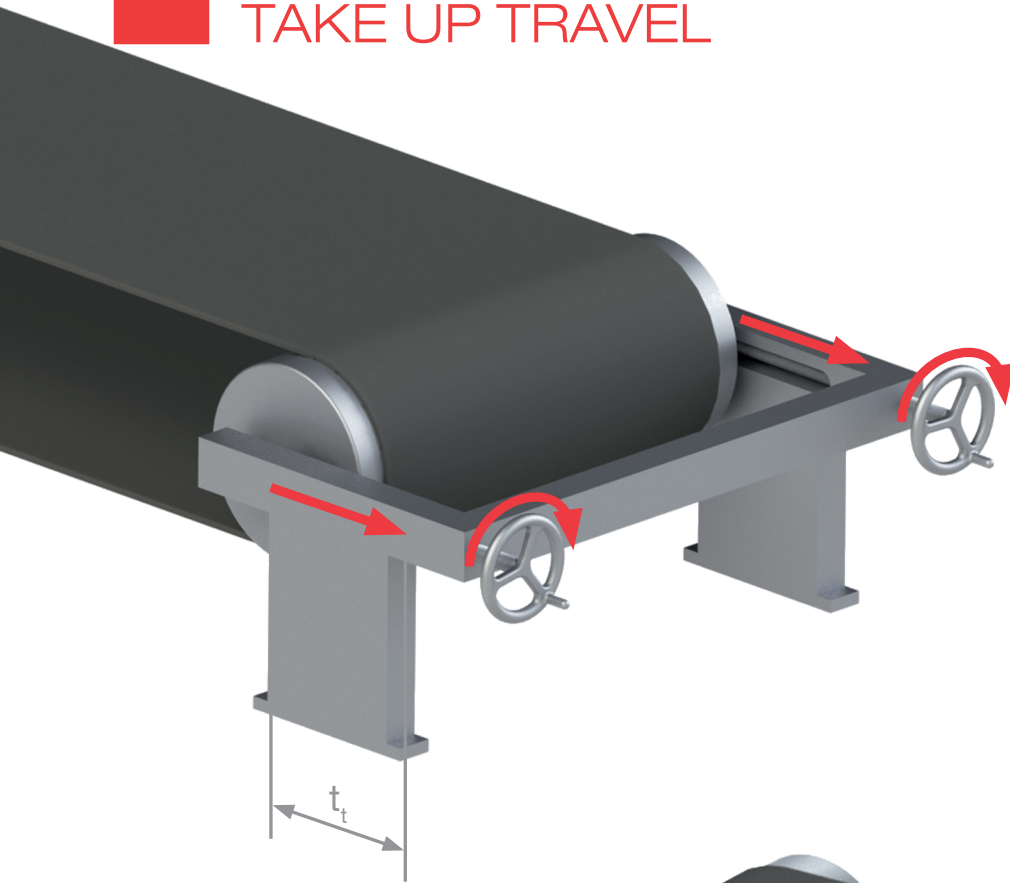

Take-up travel of textile belts

In EP fabric belts $t_t = \% 1,5 L_c$

In PP fabric belts $t_t = \% 2,4 L_c$

Steel cord fabric belt

$$t_t = \% 0,5 L_c + \frac{n \times L_s}{2}$$

t_t Take-up travel

L_c Center distance

L_s Splice length

n Number of additional splice required

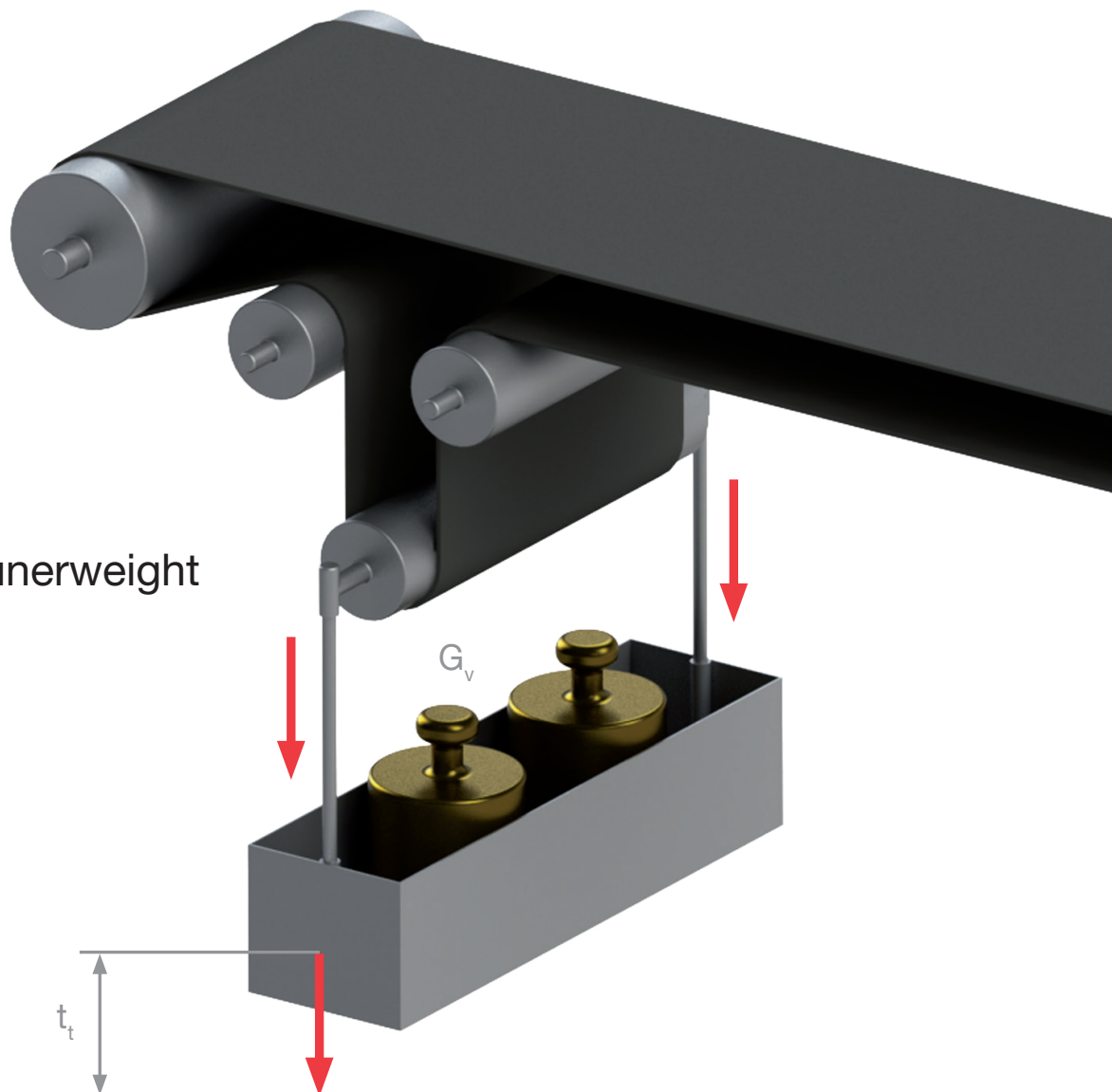

Size of the counterweight

$$G_v = \frac{2 \times T_2}{g_v} \text{ (Kg)}$$

G_v Take-up travel

T_2 Center distance

g_v Splice length



Putting into operation

Prior to tensioning, the installation should be completely checked to ensure that all idlers are in place, all bolts are tightened, all tools are removed etc. The belt may be tensioned after the splice has reached the ambient temperature.

The belt tension should be set whilst the conveyor is stationary.

The tension should be sufficient in order to avoid slip at the drive pulley. Start the tensioned belt empty and carefully check the alignment. If necessary, stop the belt after running sometimes for further tensioning. The moving belt can be corrected for alignment by adjustment of the take-up device, the snub pulley or the idlers. Care must be taken in ensuring the belt follows the correct line particularly around deflection point.

Run the installation empty until the belt travels smoothly. If the loaded belt tracks off, the installation should be re-checked for correct alignment of pulleys and idlers. Then run the belt empty again. During the initial running-in period small corrections may be required to the alignment as well as to the take-up in order to compensate for permanent stretch.

Check often the tension of the belt and take particularly cleaned the area under the belt.

STORAGE BELTS WITH SIDEWALL AND CLEATS

Sidewall conveyor belts are generally packed in steel crate with folds and edges protections.

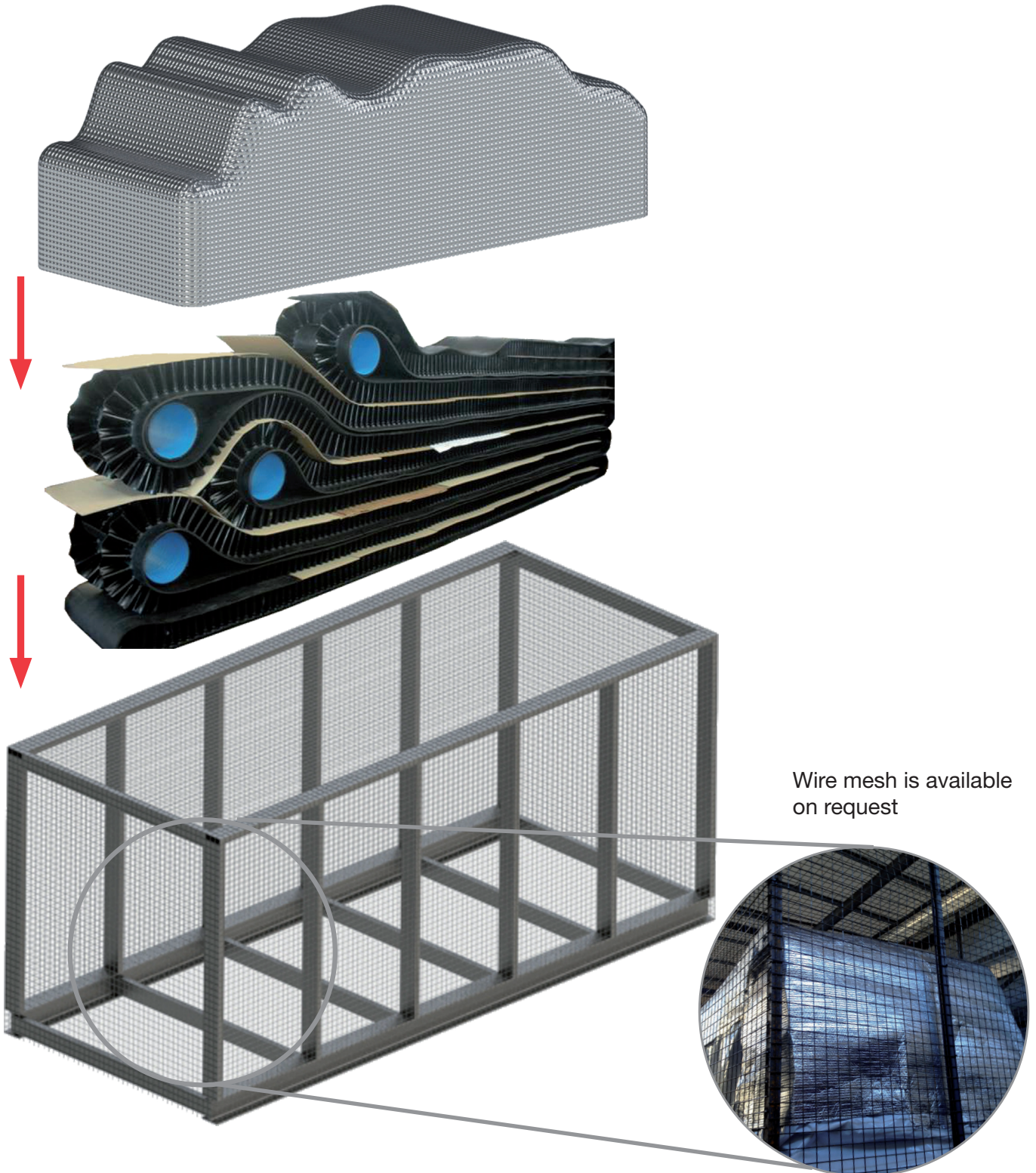

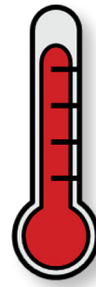

+20 °C



0 °C

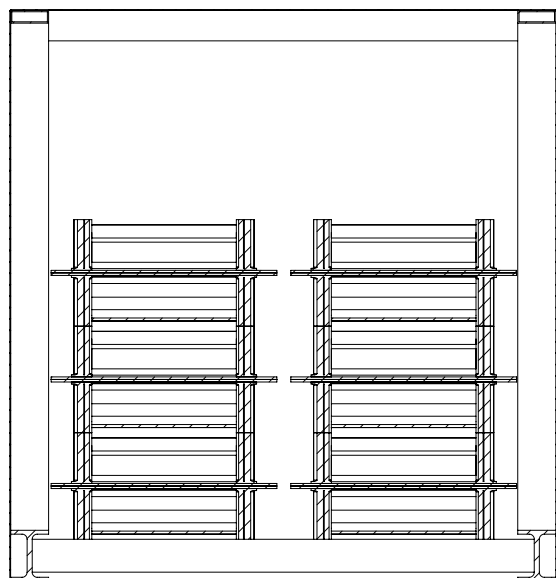
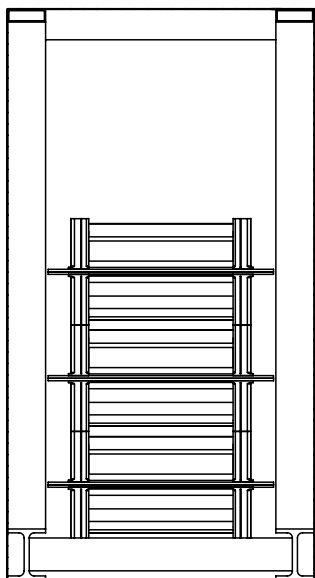



INSTALLATION BELTS WITH SIDEWALL AND CLEATS

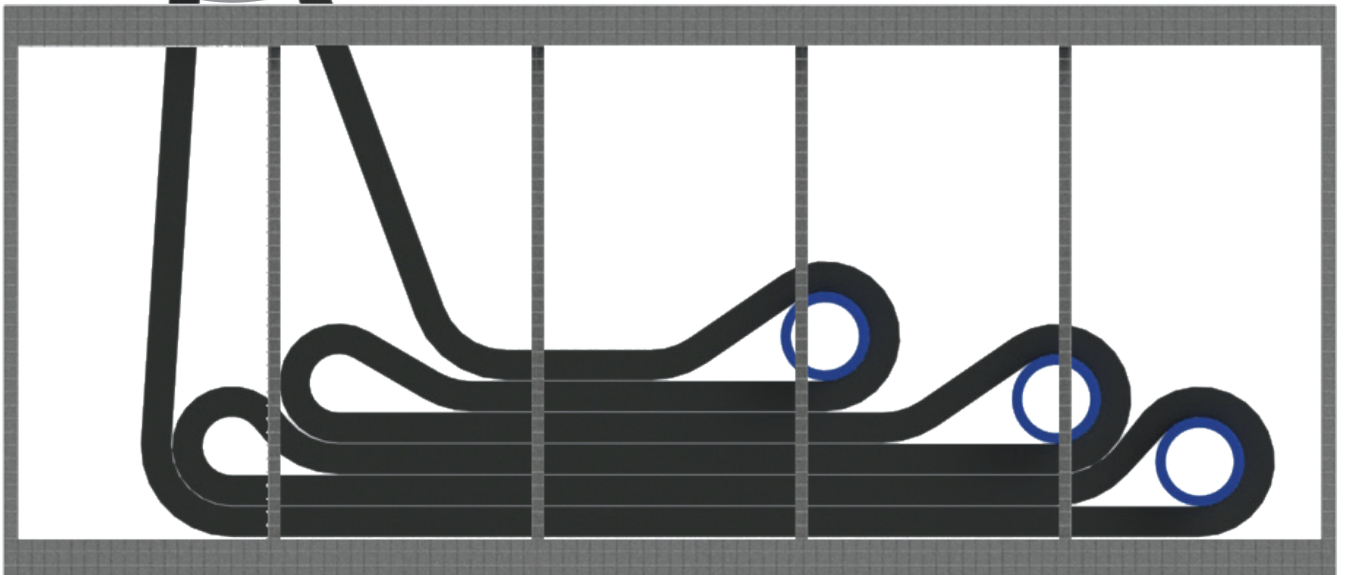
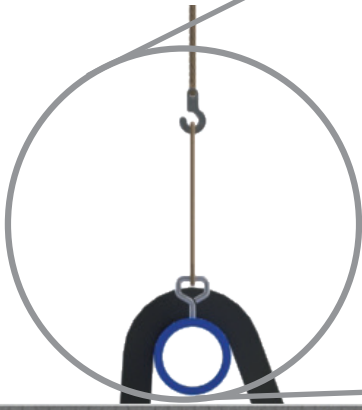
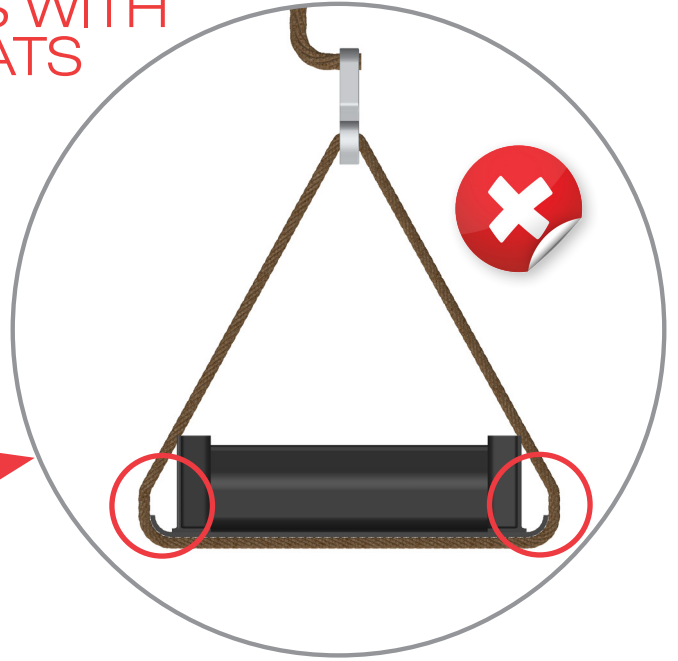
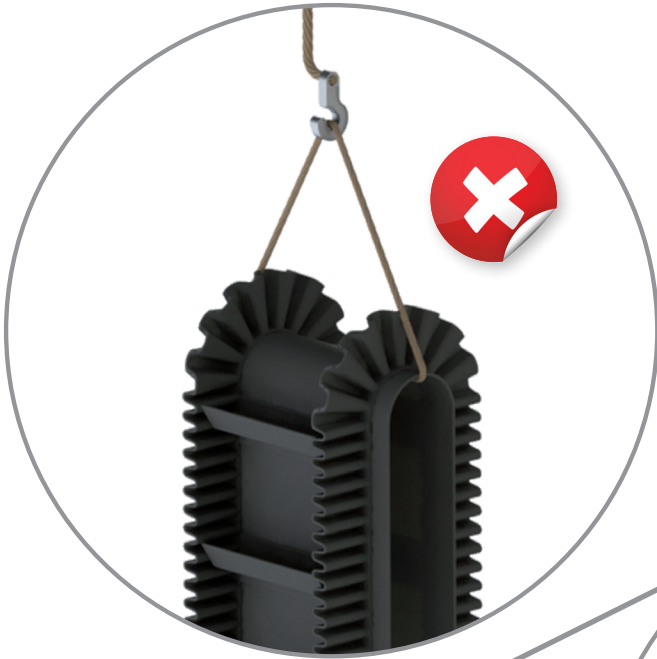



EXAMPLE OF DEFLECTION PULLEY

$R = 0,04 \times \varnothing$ deflection pulley

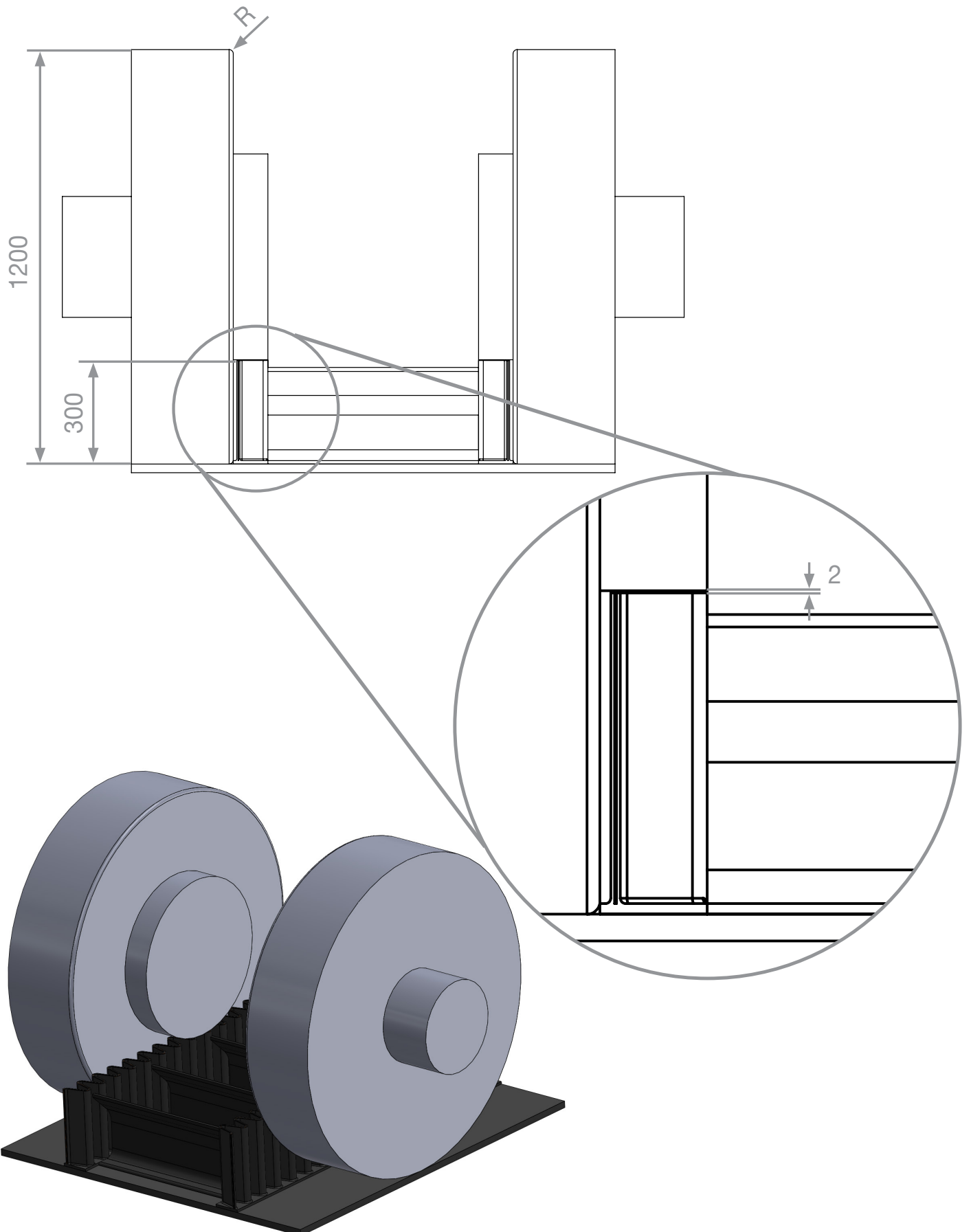



ERRORS IN BELT USAGE

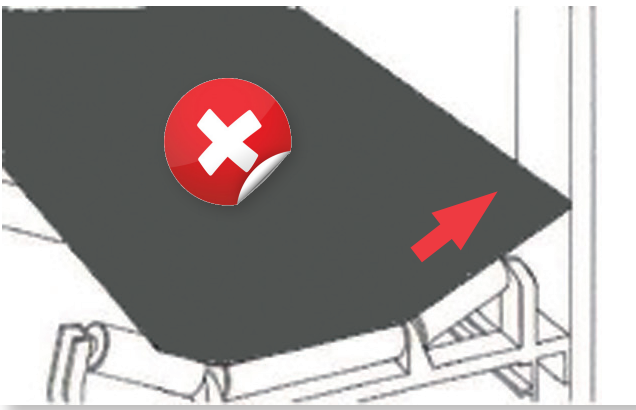

The belt runs crooked to one side at a particular part of the conveyor frame

A particular part of conveyor belt runs crooked to one side of all parts on the conveyor frame

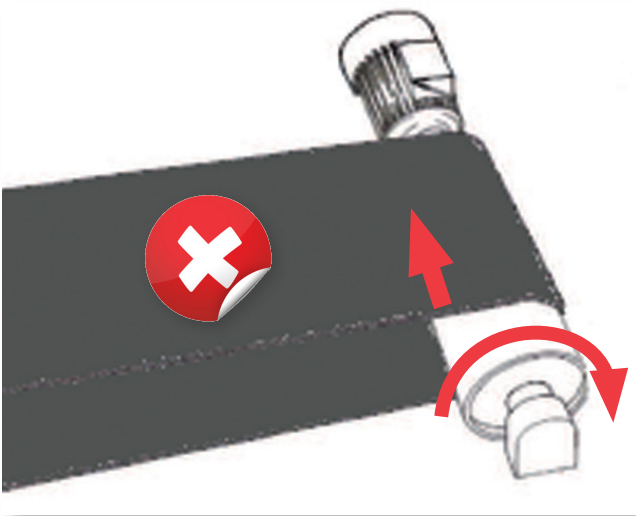

Belt leans out from the edge of drive pulley

Belt leans out aside at a specific part of conveyor

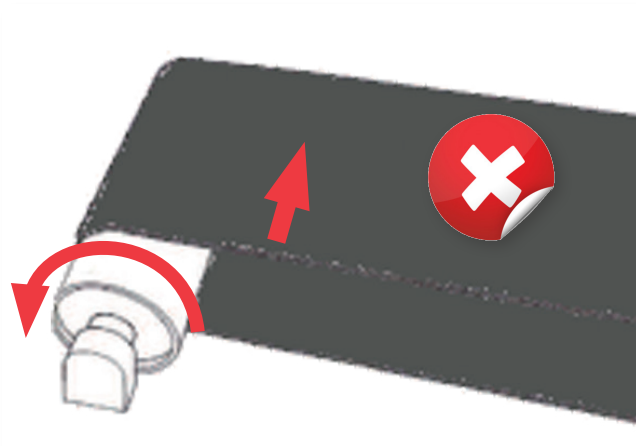

Belt leans out aside at a specific part of conveyor



Abnormal abrasion of bottom rubber

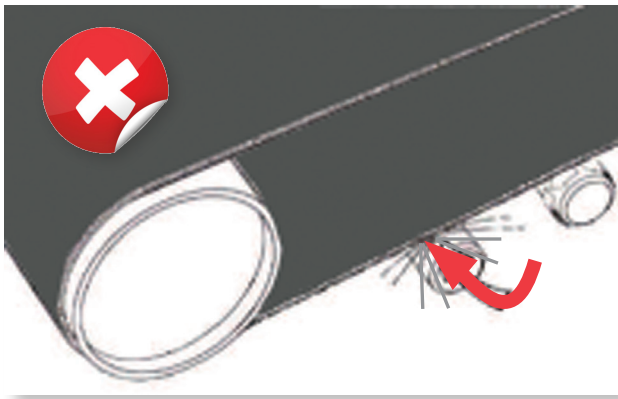

Abnormal abrasion of top rubber

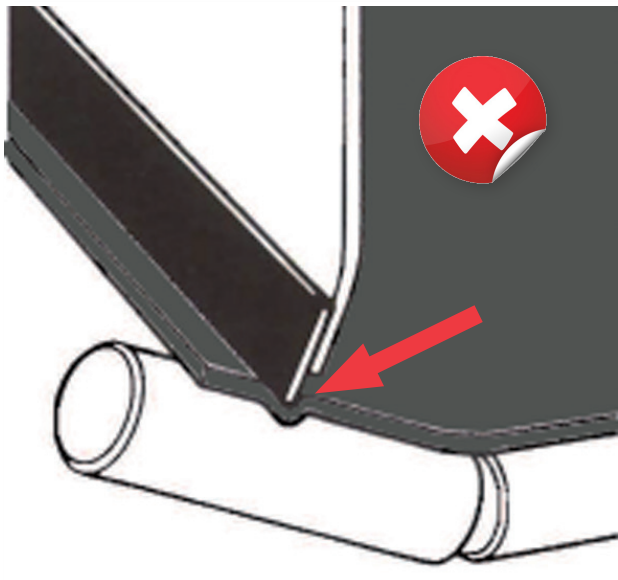

Top cover is partly carved or stripped

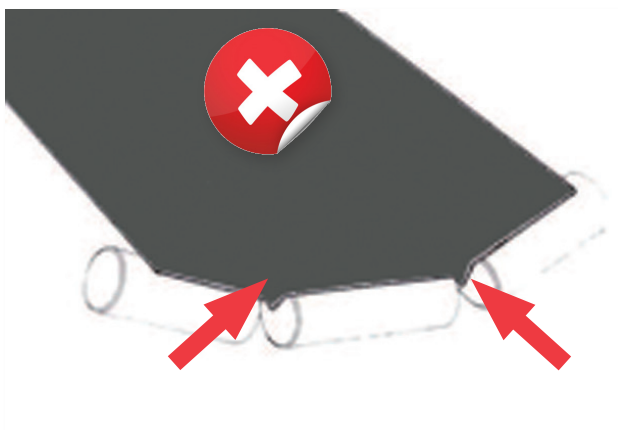

Belt and carcass is torn of in the juncture places of rollers

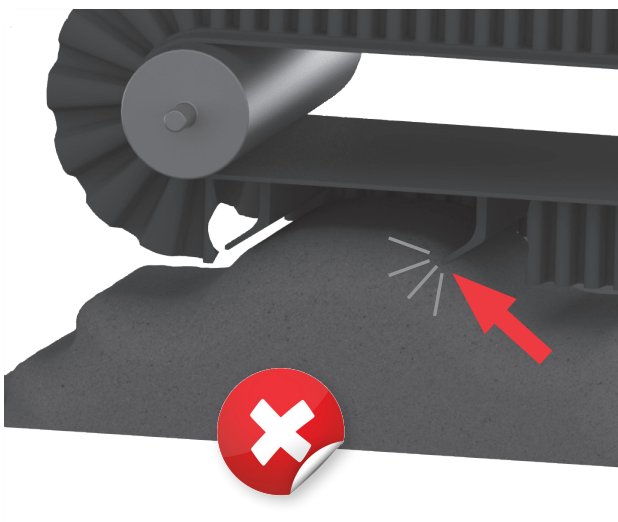

carried material accumulated on the back-side of conveyor belt

At the loading location exactly use to impact rollers

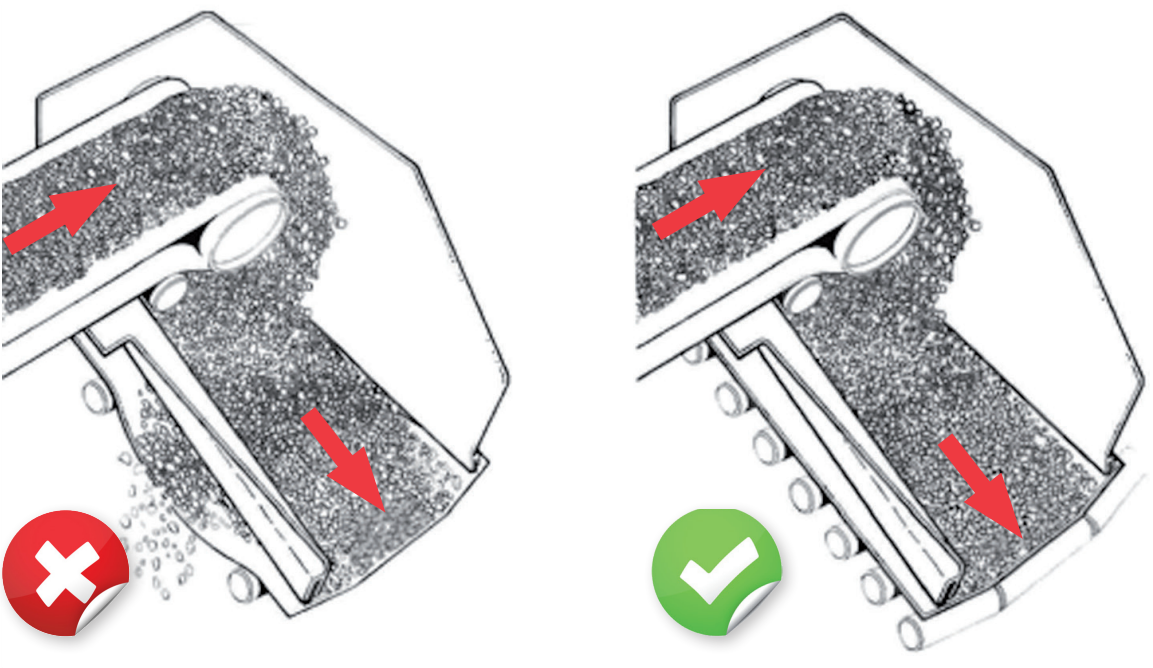

Do not neglect to use scraper before the tail pulley

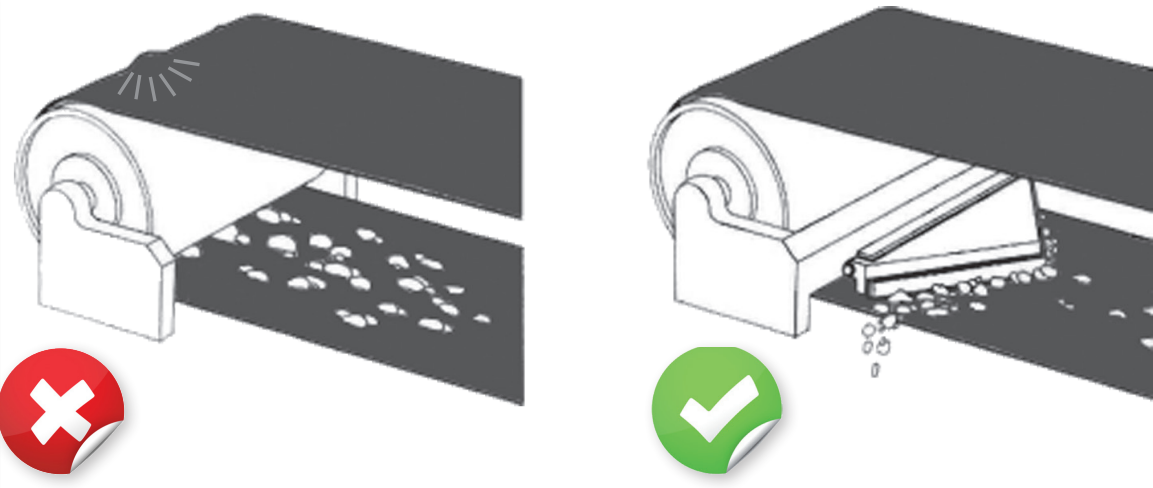

Take attention for loading become centered and smooth

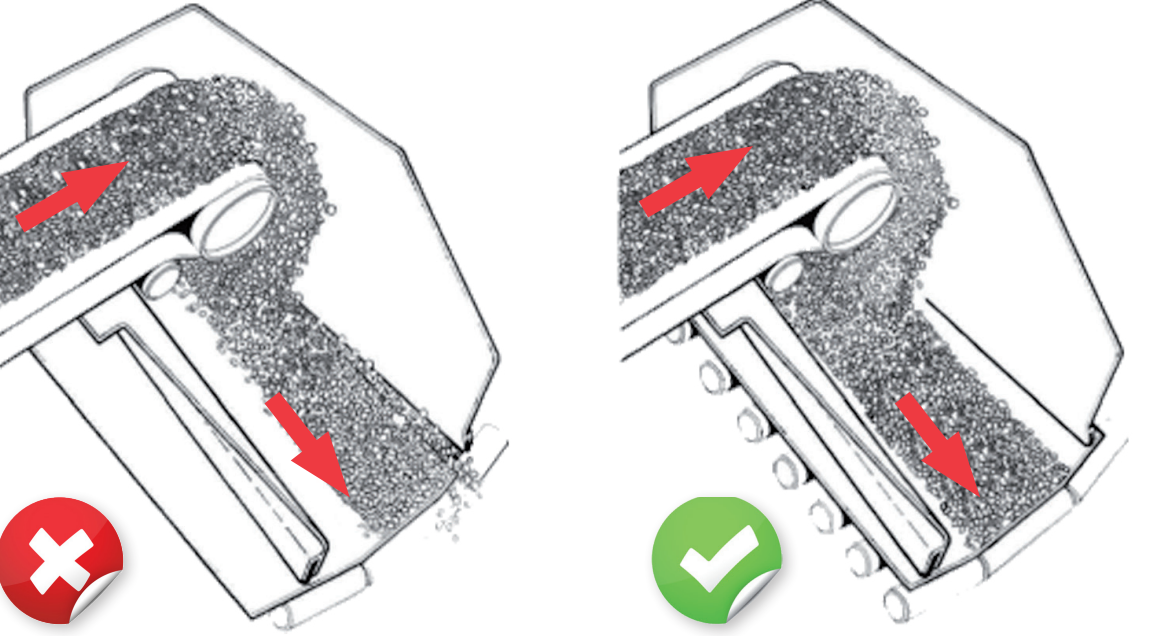

If you use take - up pulley in the system, absolutely use rubber wiper before enter the take - up pulley and protect take - up pulley.



SIDEWALLS AND CLEATS ON SITE APPLICATION

This procedure can be used to apply sidewalls and cleats on splicing area or to repair a piece of sidewall and/or replace a cleats by glue

In order to carry out this operation it is necessary to roughened, in the gluing zones, top cover, sidewalls and cleats bases through an abrasive disk which allows a better adhesion between the two parts. Taking care not to damage the fabrics below.

Clean the zone previously prepared by using a simple brush to eliminate dust and rasping rests.

Apply the cold glue follow the instructions from the manufacturer.

Apply the sidewalls to the belt and fix the ends together.

Apply the cleats to the belt. If the cleats should be bolted to the sidewalls, it is necessary to carefully respect the pitch of the sidewall waves and then glue the cleats level with the inner point of the wave itself.

In case some pieces of sidewall or some cleats need to be substituted completely remove the cleats or sidewall damaged parts and proceed as above described

LAVORGOMMA[®]
LAVORGOMMAGROUP

SHEBEL[®]line

Lavorgomma S.r.l.

Loc. Molino, 10

61026 Belforte all'Isauro (PU) Italy

T. +39 0722 721352

F. +39 0722 721963

info@lavorgommagroup.com

