

# GRP RAPID RISER

Standard 50mm  
rebate

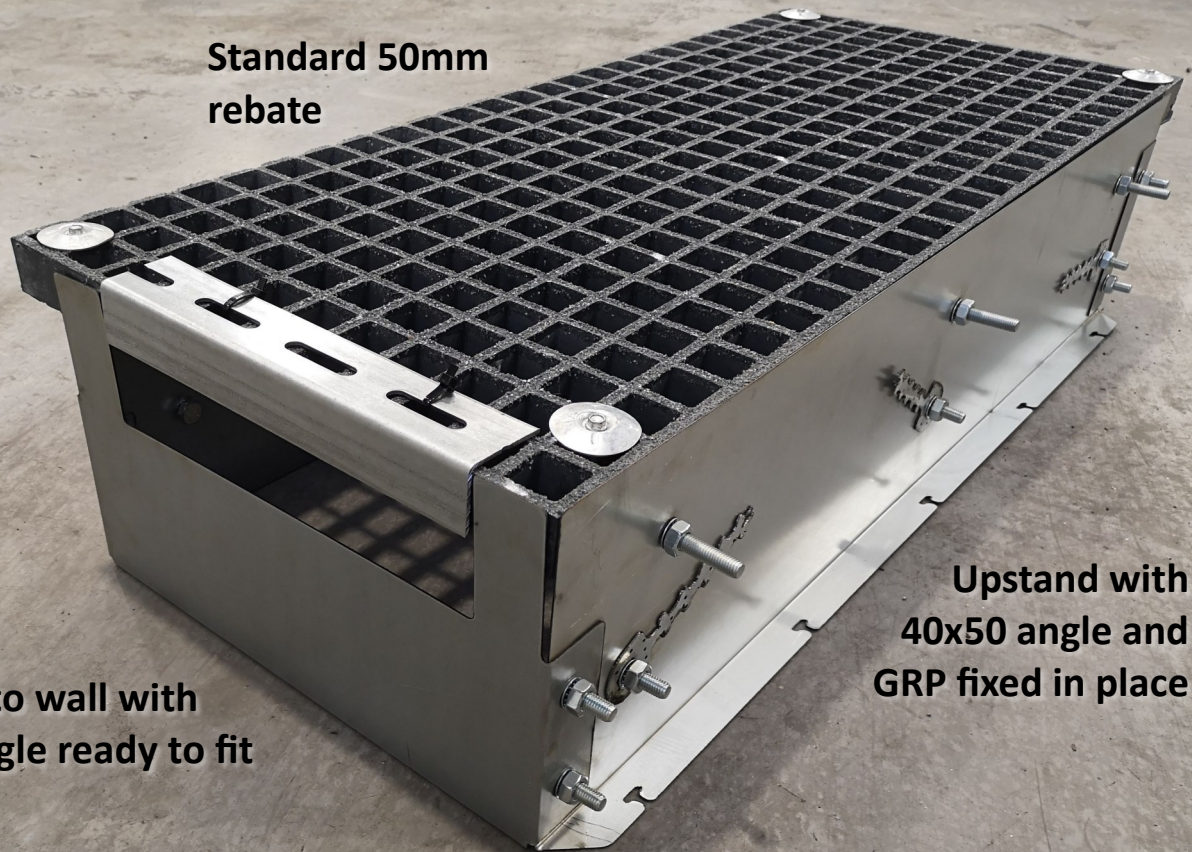

Flat end to wall with  
40x50 angle ready to fit

Upright with  
40x50 angle and  
GRP fixed in place

## MAKE THE FIRST FIX COUNT

### MADE TO MEASURE

- ✓ Manufactured to customer dimensions
- ✓ Any width, any length
- ✓ Any depth subject to practical width and length dimensions
- ✓ Non std shapes e.g. triangles, rhombus

### EASY TO FIT

- ✓ Delivered to site ready to install
- ✓ Support systems for larger width risers supplied as required
- ✓ Labelled with drawing reference
- ✓ Concrete ties for connection to rebar

### OFF-SITE MANUFACTURE

- ✓ Manufactured and assembled in a factory environment
- ✓ Maximum GRP yield using computer cutting programs
- ✓ Designs to suit kickers and core walls

### SAFER WITH NO BREAKING OUT

- ✓ No open areas in the slab
- ✓ No working at height
- ✓ No temporary works required
- ✓ No breaking out
- ✓ Saves PM and labour time on site

## MAKE THE FIRST FIX COUNT



Call : 01782 757142

[sales@firstfixformwork.co.uk](mailto:sales@firstfixformwork.co.uk)

# RAPID RISER VARIATIONS

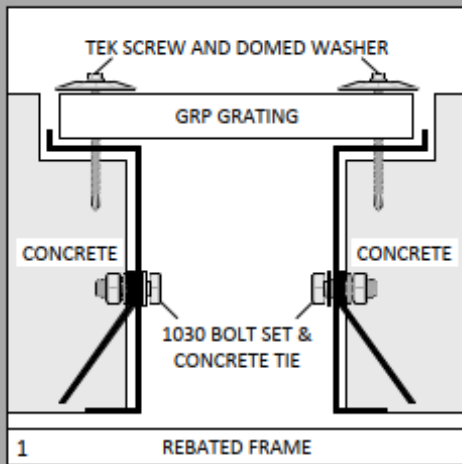

1 REBATED FRAME

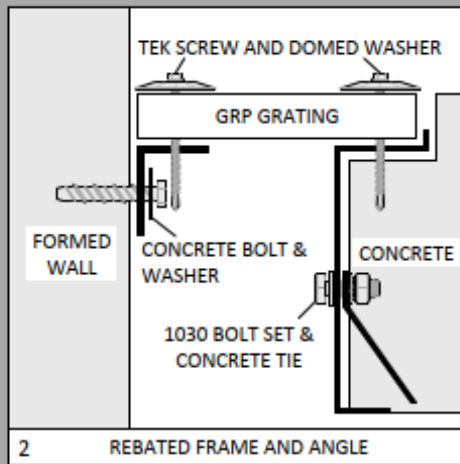

2 REBATED FRAME AND ANGLE

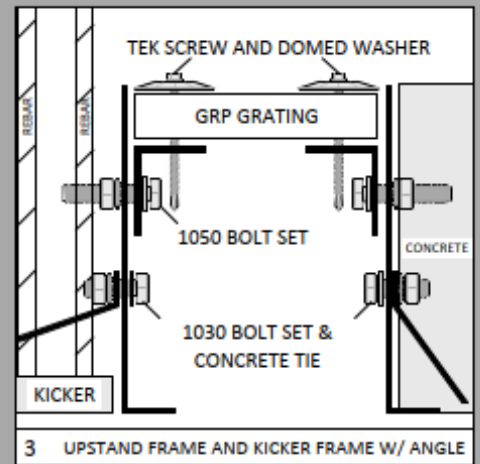

3 UPSTAND FRAME AND KICKER FRAME W/ ANGLE

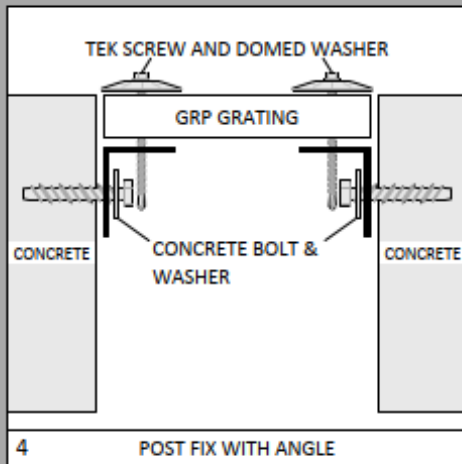

4 POST FIX WITH ANGLE

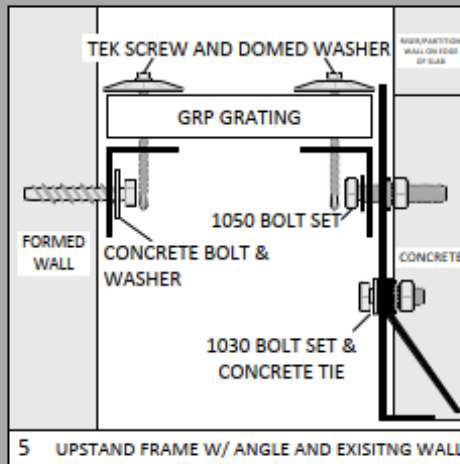

5 UPSTAND FRAME W/ ANGLE AND EXISTING WALL

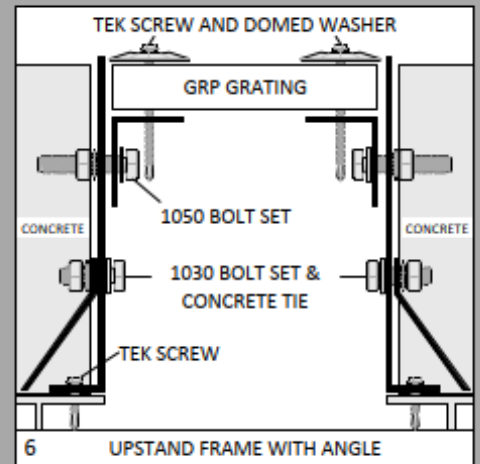

6 UPSTAND FRAME WITH ANGLE

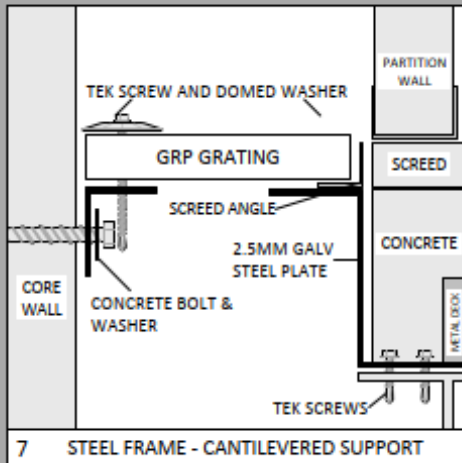

7 STEEL FRAME - CANTILEVERED SUPPORT

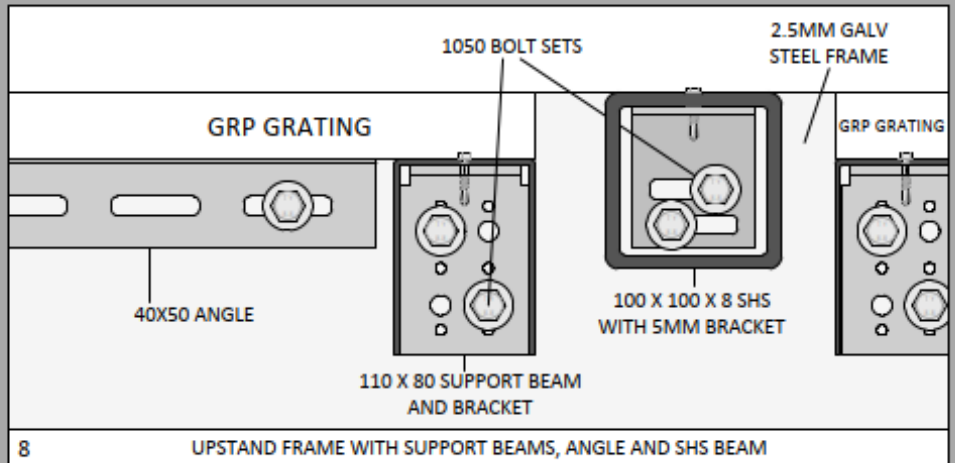

8 UPSTAND FRAME WITH SUPPORT BEAMS, ANGLE AND SHS BEAM

## Technical Information

**Manufacture :** Rapid Riser frames are galvanised mild steel of European Standard EN10142:2000, coated with zinc by hot-dip processes (Galvatite Z), including iron-zinc alloy (Galvatite ZF). The hot-dip coatings may contain up to 0.002% lead or up to 0.12% antimony. Fibreglass grating is made from fibrous glass, polyester resin, catalyst (peroxyester), styrene, aluminium oxide, pigments. Ingredients are chemically cured and bonded together.

**Personal Protection :** Suitable protective clothing covering all exposed body parts should be worn. Equipment, such as safety spectacles, and cut-resistant gloves, should be worn when handling the GRP and metal frames. Wear 3M-respirator mask No 4251 when cutting or grinding GRP. People who have a condition that could be aggravated by dust should avoid cutting or grinding GRP. Avoid breathing dust. Dust produced by cutting or grinding can penetrate the pores of the skin causing itching. When cutting with a jigsaw use Bosch T141HM blade otherwise use diamond tools.

**First Aid :** Steel frame skin and eye contact: Possible cuts from steel edges. Treat as other cuts; if required, seek medical attention.

GRP dust irritation on the skin – remove person from dust area and shower with soap and water. GRP dust intrusion in the eye – flush at once with sterile eye wash solution.

**Fire Fighting Measures :** GRP will burn. Avoid direct fire source. **Flash Point :** none. **Flammability Limits :** none. **Extinguishing media :** water, foam, A, B or C fire extinguishers. Black smoke. Carbon particles. Use air respirator. Self-extinguishing.

**Fire Testing :** Rapid Riser steel frames and fixings : none. GRP : ASTM E84 class A, 25 or less.

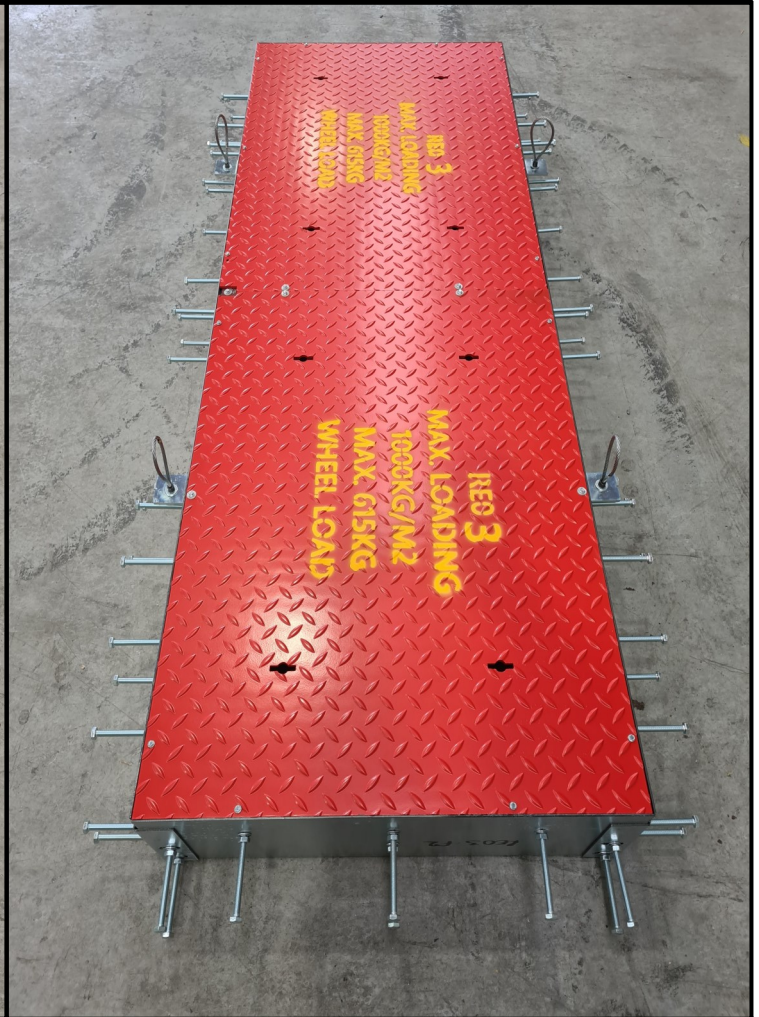

## MADE TO MEASURE

- ✓ Manufactured to customer dimensions
- ✓ Any width, any length
- ✓ Designs to suit kickers, core walls, RC and structural steel frames.
- ✓ Non std shapes e.g triangles, rhombus

## EASY TO FIT

- ✓ Delivered to site ready to install
- ✓ Support systems for M&E services can be designed in at an early stage
- ✓ 120x120 SHS for wall supports
- ✓ Concrete ties for connection to rebar

## OFF-SITE MANUFACTURE

- ✓ Manufactured and assembled in a factory environment
- ✓ Powder coated 6mm Durbar plate used to provide top covers
- ✓ Galvanised steel frames and beams

## SAFER WITH NO BREAKING OUT

- ✓ No open areas in the slab
- ✓ No working at height
- ✓ Provides a safe working platform
- ✓ No breaking out
- ✓ Saves PM and labour time on site

**MAKE THE FIRST FIX COUNT**



Call : 01782 757142



sales@firstfixformwork.co.uk