

Beyond RS

FLEX

FLEX 4096

COMPACT ORGANIC WASTE INTO 96 GALLON TOTES WITH THE BRS FLEX 4096

This robust and reliable compactor features a small footprint and lightweight design. It takes up very little floor space. The 4096 is easy, safe, and convenient to use! The multi-chamber unit offers a top-loading setup, while the single-chamber version is based on the principle "Roll in! Compact! Roll out!"



Safety



KEY BENEFITS

MORE PRODUCTIVE USE OF TIME

Less time spent on waste handling means more time for your core activities!

MORE SPACE & ORDER

The 4096 minimizes the space waste takes up and keeps your workspace neat and tidy.

LOWER COST, MORE VALUE

More compaction = less volume to transport. Fewer trips translates to lower transportation costs and reduced CO₂ emissions. Sorting at source yields a higher quality of recyclable material.



Why Beyond RS 4096?

- Versatile compaction for many applications
- Hygienic and safe compaction and disposal waste, organics, or mixed recyclables
- Specialized solutions for specific needs

Beyond RS Flex 4096

BRS FLEX 4096 IS OPTIMIZED FOR:

- Municipal solid waste
- Compostable material and organic waste
- Mixed Recycling

In-bin compaction solution

BRS FLEX 4096 is an in-bin compactor for standard two-wheeled 96 gallon bins. The 4064 Model is available for 64 gallon bins.

IDEAL FOR ORGANIC MATERIAL

The 4096 is perfect for the food service sector where organics need to be transported in toters. This unit provides impressive volume reduction, with an average compaction ratio of 3:1.



Designed for standard 96 gallon toter.

SAFE AND USER-FRIENDLY

Model 4096 is user-friendly! The multi-chamber version has a convenient top-loading installation, while the single-chamber version has an easy wheel-in, wheel-out operation. Safety and quality are our hallmarks, and the compactor provides maximum personal safety both for the operator and those in the vicinity. A bin indicator ensures that the machine can only operate when the bin is in position.

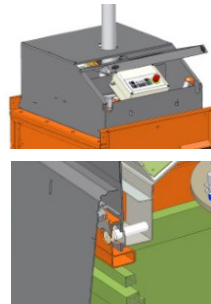

Full protection and no access to moving parts: safety switches on the hatch and the front door/apron

SMART DESIGN

The 4096 is a robust and stable machine. A quality finish and accessibility make cleaning easy!

SCALABLE SOLUTION

The compactor can be supplemented with additional chambers for rapid compaction. The front door on the single-chamber unit is replaced by an apron for easy transition of the press head from one chamber to the next.



The single-chamber unit with swing door



The multiple-chamber unit equipped with an apron with two handles

DIMENSIONS & SPECIFICATIONS

DIMENSIONS BEYOND RS FLEX 4096

A	B	C	D	TRANSPORT HEIGHT
Single: 94"	Single: 37.4"	Single: 38.6"	Single: 70.5"	Single: 83"
Double: 94"	Double: 74.8"	Double: 41.7"		Double: 83"

MACHINE WEIGHT

TOTAL WEIGHT	PRESS UNIT	SINGLE STAND
Single: 528 Lbs	Single: 265 Lbs	Single: 265 Lbs
Double: 792 Lbs	Double: 265 Lbs	Double: 265 Lbs

TECHNICAL SPECIFICATIONS

BIN SIZE	CYCLE TIME	PRESS FORCE	NOISE LEVEL	PROTECTION CLASS	OPERATING POWER
96 Gallon	29 seconds	4,400 pounds	62.3 db (A)	IP 55	Single phase 115 V, 60 Hz, 16 A

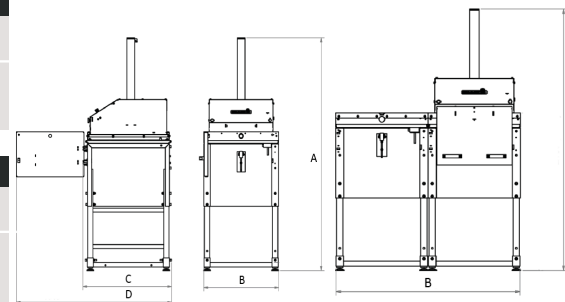

We reserve the right to make changes to specifications without prior notice. Bale/bag/bin weights are dependent upon material type.



Beyond Recycling Services, LLC
 8845 Creekstone Place | Gainesville, GA 30506 | (678) 786-8997
 Info@beyondrecyclingservices.com | www.beyondrecyclingservices.com

