

*“The Trolley”
The Official WB&A Newsletter*

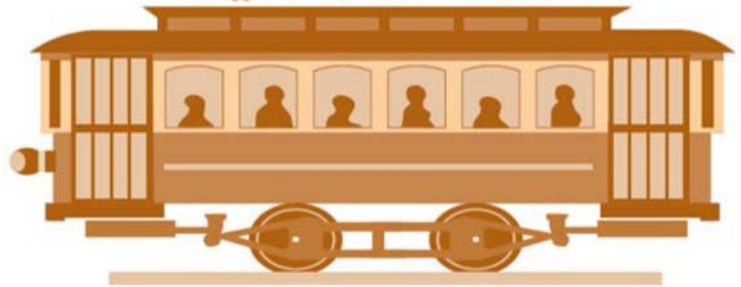

WB&A Chapter - Eastern Division - Train Collectors Association
Established 1964

Vol. 15 No. 1

Jan.-Mar. 2014

Editor - Paul Pullen

bcrr@netzero.net

Website: <http://www.wbachapter.org>

WB&A Board of Directors

Officers:

President: Colleen Hall

Vice Pres: Tom Salen

Treasurer: Glenn MacKinnon

Secretary: Nada Boswell

Past President: Art Tate

Directors:

John Buxton

David Eadie

Robert Goodrich

Robert Heine

Mary Jackson

Arnold (Arne) Meyrow

Eastern Division Representative:

Dan Danielson

Key Contacts:

President: Phone: 540.622.2258

E-Mail: memberwba@gmail.com

Secretary: Phone: 703.536.8060

E-Mail: WBA.boswell@gmail.com

Membership: Phone: 703-451-4149

Train Shows: Phone: 410.974.0373

From the President-elect's Desk

Dear All,

I'm in awe over the events of the past 12 years and where I am today. Many of you who I have had the pleasure of meeting and speaking with over this time period has most likely heard me talk of my husband, James, and how proud I am of him and all that he has accomplished over the years. You see when I first met James I walked into a tiny efficiency and looked in wide wonder at the boxes and boxes of trains that was contained within the walls of that efficiency. I looked up and saw two O' gauge tracks running along his ceiling that often had trains running and smoke a billowing out of it. This scene brought this tiny efficiency to life and it brought the others of that building together to watch and to enjoy the trains running, horns blowing, and steam puffing. This was my introduction to this world of trains and the magic of how it brought people together. From this one room apartment to where we live now, what has changed in our living space is, it has grown from a 192 square feet to 8864 square feet. However, James' vision and hard work has created a train room that brings friends from around the world to visit to enjoy the running of our trains. You may ask how does this qualify me to be the President of the WB&A as the knowledge of trains belongs to people such as my husband, Clem Clement, Dan Danielson, Glenn MacKinnon and others such as them who have graciously shared with me their knowledge about trains. I had to step back and realize that my interest lies in the meaning behind all of this, it lies with what this hobby has brought to so many and how it impacts one's life and what it offers both the old and young. You see I will never be the one you can walk up to and say "can you tell me what this is worth," "can you tell me who made this," "can you..." No, I will never be that person for what is of meaning to me is, let me show you what playing and collecting of toy trains has given me and what it can give you. Let me explore with you the ways we can keep this hobby moving forward long after you and I are gone from this world. Let me travel down these tracks with you and let us together pick-up others that didn't even know these tracks existed, let me take you along this ride where memories of yesterday live and the promise of a tomorrow is there if we only take the hands of others who didn't know of this tracks existence. So you see, my vision is that of the continued existence of this hobby and of this Club so that we all live on through the legacy we leave behind. So while I don't have <Cont'd on Page 2>

<i>In This Issue</i>	<i>Page</i>
President's Message	1
Treasurer's Report	2
Secretary's Report	2
Listman Open House Invitation	3
Historian's Corner	3
Membership Moments	4
Box Magic of Dreams	4
View from the Observation Car	7
The November 2nd Swap Meet	8
Rube Goldberg Transformer	10
Catoctin Mountain Trains and Hobbies Open House	11
Next Study Group Invitation	11
The Little Wooden Railroad that Could	12
The Little Station that Could	12
Cleaning Trains	13
Lionel Standard Study Group	17
New Train Store!	18



Treasurer's Report as of Dec. 13, 2013

By Glenn MacKinnon

The WB&A has had a great year. Two outstanding train meets, swap/membership meetings for members only and a first class up to date website are just part of the story. WB&A is providing real value to the membership thru the behind the scenes hard work of the Board of Directors and a select few contributing members. To take the chapter to another higher level, the membership needs to step up and make things happen. The question is no longer what the Chapter doing for the membership but, what is the membership willing to do for the Chapter and the toy train hobby. We need our layouts repaired and updated, fresh inputs to our website and Facebook page and members willing to take on some responsibility for orchestrating activities/events for the membership. We have the resources to support new initiatives. Who will be the first to step up to the challenge? The Chapter's financial activities for January-December 8, 2013 are summarized below. If you have any other questions or comments feel free to contact me at 703-927-9843 or glen.mackinnon@verizon.net.

Check Book Balance—Jan. 1, 2013 \$34,252.47
Check Book Balance—Dec. 8, 2013 \$30,706.80

Significant Activities Jan. 1, 2013 through Dec. 8, 2013

	Expenses	Revenue
MD Armory Mar 2013 Meet	3405	5343
MD Armory Mar 2014 Meet	390	
Vienna, VA Meet	2535	1606
Membership Dues 2013	168	4788
Membership Dues 2014	44	2660
Newsletter 2013	4208	340
Kids Korner	589	545
Swap / Business Meeting	941	
Door Prizes for Swap Meet	571	
Train Set for Drawing	831	1120
WB&A Layouts	168	
WB&A Trailer	645	
Web Site	3181	
Questionnaire + Mailing	349	
TCA Division—Chapter Appeal	1000	
Outside the Lines (Nancy Swan)	65	
Danny Martin Retirement	100	
Election of Officers	710	
Miscellaneous Expenses	118	



TOP TEN WB&A BENEFITS

- 1 Fun and Fellowship with your Train Friends
- 2 Wealth of information available from other collectors, operators and layout builders.
- 3 A wonderful opportunity to participate at the local level in the world's greatest hobby.
- 4 Free admission to local WB&A Train Shows. (Show advertised in local newspapers).
- 5 Free admission at Members Only WB&A Swap Meet.
- 6 Receive quarterly the WB&A Newsletter "The Trolley".
- 7 Access to the chapter website - <http://www.wbachapter.org>
- 8 Share in the excitement of the Toy Train Hobby.
- 9 Serving as a committee member or officer at the local level is very rewarding.
- 10 Buy, Sell, Trade with local train enthusiasts.

Share Your Memories

Please send any train-related articles, stories, and/or print-ready photos for consideration in any upcoming publication of "The Trolley" or on the Chapter Web Site. Send via e-mail to: bcrr@netzero.net

**DEADLINE FOR SUBMITTING ARTICLES
FOR April 2014 TROLLEY
Mar. 14, 2014**

President-Elect's Desk (Cont'd) all of the answers to the "can you tell me" questions, I as your President will strive to find ways to make this Club better then when I joined it and invite you all to share with ways that I can do this. I would like to believe that you are all members of this Club because you get something from it and that the future holds a promise that the hobby is not swallowed up by the technology that our children too often is so caught up in that they never hear the words "ALL ABOARD." So to you all, I say ALL ABOARD and please join me for the next two years while your BoD works on ways to make this Club even better than it is today.

Warm regards to you and yours and I am honored to take on this challenge of the President of the WB&A.

Colleen Hall
President

Overlea, MD
Street Car
Turn-Around
Circa late
1950's courtesy of Mike Robertson.



Listman Open House Invitation

December 2013

Dear Fellow TCA Member:

Once again, Ken Listman (Member #73-5051) is opening his home to TCA members. Ken tells us: "I have built an 80 foot 'O' gauge layout in my basement that I love sharing. For the past four years, I have held an Open House for TCA members and friends. I ask everyone to make a donation to TCA. My TCA friends and I have raised a total of \$10,900 for the TCA as a fundraising effort!"

We're excited to be repeating the Listman Open House for 2014, and we'd like to invite you and your friends to come, see the layout, and enjoy visiting with other TCA members. Some of the Board of Direc-



tors will also be present for questions and answers. We hope to collect more for the TCA in 2014 through your generosity. Contributions given by check are referred, so that you can use your gift as a tax deduction. There will also be envelopes for cash donations, and you can write your name and TCA number on the envelope.

The Listman Open House will be on Saturday, January 4th and Saturday, January 11th from 12:00 p.m. to 4:00 p.m. Due to the unpredictability of the weather during this time of the year, January 18th has been set aside as a snow date. Please feel free to bring a friend—applications will be available to any individual who wishes to become a member of the TCA. What better way to spend a cold winter's day than to play with trains in the company of your fellow TCA members?

A map to my house is shown on the back. I hope to see you here!

Ken Listman
2006 Huntfield Court
Fallston, Maryland 21047



(Courtesy Tim Steir
TCA National Business Office.)

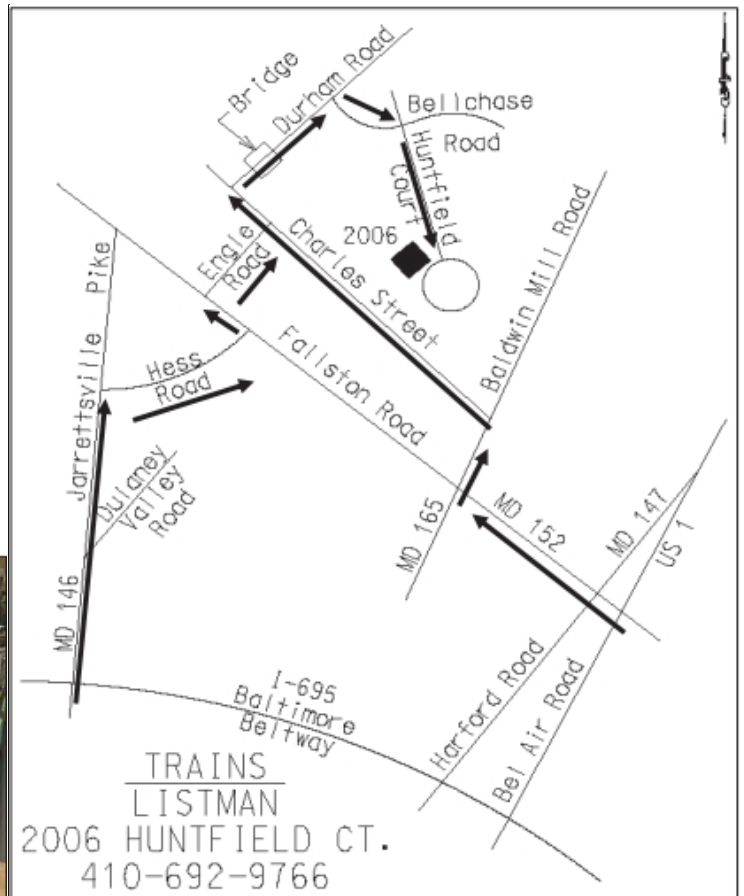

Historian's Corner

TCA is 60 years old. I'm still trying to wrap my head around this. (Actually being 60 is something I've had to wrap myself around this year!) I have really grown up with TCA, and the issues that we face today are issues that we faced previously. There are no canned answers, no quick fix, but the challenges still remain.

If you look at the TCQ (Train Collectors Quarterly) Vol. 1, No. 1 it talks says "Many persons have asked about our printing the Quarterly, and including pictures. This is very desirable, but the cost would be too great to be borne by our present membership. Printing will remain under consideration." Look how far we've come.

So that being said, get out your Union Pacific Challenger, #3985 or #3977. Put it onto a track and watch her run. It was built to get trains up and over the Wahsatch Mountains in Utah. Or if you don't have a Challenger, then run your favorite trains. Invite friends or family to come and see it run, or see you displayed trains. Either way **Take the Challenge!**

Keeping the wheels down and the smoke up,

Respectfully submitted,
Carol Redman McGinnis
WB&A Historian, TCA President
11/21/13

Membership Moments by David Eadie

WOW !! Can you believe its the end of the year. We've had a great year in our membership drive and we thank you for that. We met many of our members at the two mini meets held this year at the masonic temple in Falls Church and the new one held at St. James Lutheran Church in Overlea, MD. Both of the WB&A sponsored Train Shows held at the Annapolis Armory and the new Vienna Firehouse location were a huge success. Thanks to all members who attended and showed their support for the WB&A chapter. Did I mention the two York meets and the trips to the Catoctin Mountain train store. Many of you took advantage of these shows to renew your membership. As of December 1st , over 100 of of you have paid your dues for 2014 and will have a chance at win a \$ 100.00 gift card from Catoctin Mountain train store. For those who joined us at cmtrain store in Thurmont, Maryland on November 11, you would have seen many opportunities to spend that \$100 gift card. Paul and Marcia Johnson have a wide selection of Lionel and MTH, old and new.

So far this year we have added 21 new members, many joining at one of the train shows. We appreciate your interest in the chapter. Please consider volunteering in some way to help out, be it at one of our shows / meets. or repairing / upgrading the layouts we use at these shows. Any of you having an interesting story to tell, our Trolley news editor Paul Pullen would be glad to hear from you.

BOX MAGIC OF DREAMS

The lady was walking up and down the hallowed halls of York wither husband as he was in his glory looking and talking about all the wondrous trains. She was content in her own thoughts and comfortable that he was in is day. As they passed my table I remarked something about the nice day and the good times for us. As she waited for her man, to help pass the time, I remarked that I had a box of small toy cars of which one was free if she was under 18. A silly remark by me but I'm known for silly thinking. She thanked me and delved back into her thoughts. I brought the toy box over to her and she shook her headsuddenly there was the slightest flicker across her face. I think it was God passing thru. Perhaps to get the subject out of her thinking or perhaps into her thinking, in a quiet voice she murmured that she did have a grandson who liked yellow. Was there

a yellow...ah. Into her curled well-used hand a little yellow racer found a new home. Only a nod occurred but I noticed the little yellow racer snuggled up in her many-times-over 18 hand as she moved on in the hall of dreams.

A under 2 was bringing has dad down the isles. Things were not comfortable and Dad was taller and the little tyke could not see nor touch the toys in this place. Uncle Clem had his box of dreams and he set them on the floor. Uncle Clem's bones creaked as he got down on the floor and both kids had their noses in the box of dreams. The boy was so young that turning over a car to see its topside was not in his thought process, so Uncle Clem helped and he pondered (Actually he was too young to know what pondering was but Uncle Clem was right there in the box of dreams with him nose to nose.) Words were not spoken but shape and size seemed more important that color. Suddenly two random cars jumping into his little hands (You see he had two hands so he had to have two cars) and the moment passed unseen by many except his Dad and Uncle Clem, who had trouble getting his footing with the blur in his eyes.

The box of dreams has many secrets. It seems never to be empty and always has something to catch a youngen's eye or cause the oldest to see his childhood in the box of Dreams. An 8 year old went thru the box and showed me which of the cars he had. When asked if he wanted a duplicate, his wrinkled up face told me "No way Dude! I want one that I don't have." He did have a story to pass about a green racer that had a terrible crash at his place and might should be replaced, but then the red truck came into view.

(I wonder if I should put a frog in the box of dreams.....no)

The source of the magic in the box of dreams is the famous old car parts show at Cowtown, NJ; my home state. I feel the magic as I cross the Memorial Bridge into Jersey and the soils of my youth. I have been going to Cowtown since the 40's and love every trip back there. There as several dealers in toys and some have tubs of well-loved little cars just waiting for a new driver's sweaty hands.

(It is late a night now as I type. I'm going to stop now and go into the dark garage to see if the cars in the magic box of dreams are ok...)

Clem

**WB&A 2014 MEMBERSHIP
NEW/RENEWAL APPLICATION**

Return with Self Addressed Stamped Envelope & a check/money order for \$18 payable to WB&A.
Mail to: David Eadie, 7825 Wintercress LN, Springfield, VA 22152

Name _____

TCA# _____ WB&A# _____

Address _____ Apt# _____

City _____ State _____ Zip Code + 4 _____

Home Phone _____ Cell Phone _____

E-Mail _____

Signature _____

Please contact David Eadie at 703-451-4149
or dbeadie@verizon.net with any questions.



***Don't Miss Out on the chance
to win the WB&A Drawing for a new Premier Line
Southern Steam Passenger Set with Proto-Sound 3.0***

4-6-2 Ps-4 Steam Passenger Set w/Proto-Sound 3.0



Product Line: Premier

Roadname: Southern

4-6-2 Ps-4 Steam Passenger Set w/Proto-Sound 3.0 - Southern

Set Features: Southern 4-6-2 Ps-4 Steam Engine (Cab # 1393), (1) Baggage Car (), (2) 70' Heavyweight Madison Coach Car (), (1) Heavyweight Madison Observation Car ()

Product Number: 20-3463-1 M.S.R.P. \$ 999.95

Borrowed from the MTH Website.



Winner to be announced shortly!

***Contact any WB&A BOD Member for tickets, or send a
check to Treasurer, Glenn MacKinnion, 6908 Trillium Ln, Springfield, VA 22152.
Your tickets will be sent by return mail to you.
(1 for \$5 or 6 for \$25) Only 500 tickets are being sold.
Drawing to be held in December.***



Upcoming Train Shows

Jan 4, Jan 11, 2014	Ken Listman Open House
Jan 5, 2014	Dan & Hope Danielson Open House
Jan 18-19, 2014	World's Greatest Hobby , Oaks, PA
Jan 25, 2014	Greenberg/Clement Trolley Study Group
Feb 23, 2014	Sandy & Clem Clement 41st Annual Open House
Mar 15, 2014	WB&A Toy & Train Show, Annapolis Armory
May 3, 2014	James & Colleen Hall Open House
Jun 7, 2014	WB&A mini-meet, Kemper – Macon Lodge
Sep 13, 2014	WB&A Toy & Train Show, Vienna, VA



REPAIRS

PARTS

BUY/SELL ELECTRIC TRAINS
LIONEL — MARX — AMERICAN FLYER
 TCA - TIOS - LOTS
 86-23598 7520 700

LOOSE CABOOSE

Robbie Schroeder 12824 MEADOWBROOK LA.
 301-843-8769 WB&A 1734 Waldorf, MD 20601
 NOW SELLING ALFRA ENGINEERING PARTS
 NO LIST YET STILL ORGINIZEN CALL WITH NEEDS
 SPECIALIZING IN LIONEL PARTS

Hope & Dan

Collectors of Old Trains, Toys,
 Diecast Cars, Hollowcast Figures



Hope & Dan Danielson
 13439 Fieldstone Way
 Gainesville, VA 20155
 703 743-2152

prewar@comcast.net

postwar@comcast.net



Boxcar Brian Reilly

Quality Trains and The Truth About Them
 PRE-WAR • POST-WAR • MODERN
 LIONEL • AMERICAN FLYER

10121 Chesney Dr.
 Spotsylvania, VA 22553
 540-834-0160
 BoxcarBR@verizon.net



Look who just joined WB&A!!!

Charles Miller	Columbia, MD
Bill Moss	Hyattsville, MD
Ron Mascaro	Severn, MD
Martin Riley	Glen Burnie, MD
Karl Kruelle	Newark, DE

Allen E. Crotts
 TCA 95-41208



Pre-war
 Post-war

AL'S TOY TRAIN SERVICE

Specializing in
 Lionel & American Flyer
 O,S and Standard Gauge
 Call for an appointment

WB&A 1219
 VTC 98-1031

Falls Church, VA
 703-536-7657

Old Photos and film deteriorate, now's the time to transfer all those treasures onto permanent media. Don't wait until it's too late! Why not a DVD with all your movies and pictures?

Weddings
 Birthdays
 Vacations
 Reunions
 Sporting Events
 Graduations

Call or Email
 Glenn MacKinnon
 To discuss the process and get a quote!

703-927-9843
 Glen.mackinnon@verizon.net



View from the Observation Car **By George Tsakiris**

It's About the Relationships!

If you read this article (thank you by the way) then you are a train enthusiast. You probably enjoy your collection, buy that engine that you MUST have, work on your layout, go rail fanning, run your trains, and consider having to stop at the railroad crossing when the gate drops makes for a good day. Lately I've been thinking more and more about another aspect of the hobby, sharing it with others and the resulting relationships.

I remember re-entering the train hobby, joining the WB&A and the National Capital Trackers (Trackers), getting warm and friendly advice, and starting many new friendships and acquaintances.

This article is written around the Holiday season. Lots of train events to go to. As a member of the Trackers there are lots of venues to setup and run trains for the public. It's a great chance to continue old friendships, meet new people, catch up on what is happening in each other's lives, and talk shop. I've been involved in three different train shows in the last ten days!

At the College Park Aviation Museum Holiday Trains and Planes show, a fellow asked how he could run his trains on our layout and replied, all you have to do is join up and help out. The benefits of joining were discussed including the various layouts and venues, technical knowledge of the members, but most importantly the warm friendships that he could enjoy.

Then got to thinking about the Trackmaster for the College Park Aviation Museum shows that recently passed away, Rich Myers. Rich was always warm, friendly, helpful, and generous with his time. His passing away this year was felt by many and left a void. Realizing that makes me appreciate my time with friends all the more.

When train people get together for an event we are working together for a common goal and passion. So, get out of that basement train room, join in on a train related activity, and connect with friends old and new. The WB&A sends out weekly e-mails of current train activities so there is no excuse! Remember, it's about the relationships!

Shameless Plug for the National Capital Trackers Layout at York

I have the honor to have been chosen as co-Trackmaster, along with Justin Krause, to manage the National Capital Trackers layout in the Black Hall at 2014 Spring York! We promise a fun layout that is

currently planned to be in excess of 100 feet! Come on by and say hello!



WB&A Members at Catoctin Mountain Trains in Feb. 2013



Rich Myers and Bob Easton



National Capital Trackers at Celebrate Fairfax



The November 2nd Swap Meet

by Bob Goodrich

The November 2nd Swap Meet was held for the first time at St. James Lutheran Church in Overlea (Baltimore), MD. Paul Pullen, my Co-Chair, and I would like to thank everyone who attended. Paul also



put together a small tabletop layout, with a homemade transformer, PowerMaster -1 and Cab1 so we could run stuff. As always, there was plenty of food, fun, trains, and fellowship with friends. Charles Bell came and showed us how he made tanker cars out of beer bottles. He actually hand makes the car frame to fit the contour of the bottles. Then he cuts the bottles, glues

them together and fastens them to the frames.

Charles Bell and his Beer Bottle Trains



Charles then adds the trucks to the frames and applies the beer company logos and caps. Very unique!!

This is also the time of year when we hold elections for WB&A Officers and Board of Directors positions that are open as of the end of 2013. Dave Eadie, Dan Danielson and I served as your Nominating / Election Committee.

Here are the results, for the 2014-2015 term, from the ballots that were opened and counted at the Swap Meet.

Congratulations to:

President: **Colleen Hall**
Vice-President: **Tom Salen**
Treasurer: **Glenn MacKinnon**

Board of Directors: **John Buxton**
Bob Heine
Arnold (Arne) Meyrow

Thanks to all of you who were willing to be nominated for and serve in these positions! Thanks, also, to St. James for allowing us to hold this Meet!

Steve Burket and David Eadie discuss trains.



Hope Danielson studies line drawings at the show.

December's Drawing Items on the WB&A Table.





Rube Goldberg "Transformer"

Paul Pullen

At the November 2nd Swap Meet/Business Meet, I set up

a small, inverted figure eight layout on an approximate four foot by four foot space. Several years ago, I finally decided to go into the almost 21st Century with my train controls, and had purchased a Lionel PM-1 Power Master and a Cab-1 controller. This was my first (and only) purchase of smart locomotives and trains for my railroad. I have had a couple of "smart" locomotives over the years, but have been very unhappy with the operations of them on my conventional layout. As a result, I now have a completely conventional MTH Pennsylvania Consolidation and a K-Line two truck shay locomotive. I pulled the control boards out of each engine, and replaced them with Williams electronic E-Units.



Then, last year, I decided to liquidate a majority of my post-war Lionel trains. The liquidation also included selling my ZW transformer. I had been running my PM-1s and Cab-1 with my Lionel Type R transformer with no problem. However, I was looking at the possibility of having a fixed, higher current power module for the trains. So I went to work building the Rube-Goldberg. This sub-assembly attracted quite a bit of attention while I was walking around running the layout with wireless connection.

I started with a pair of transformers that I have had in my possession for over twenty years, and fig-

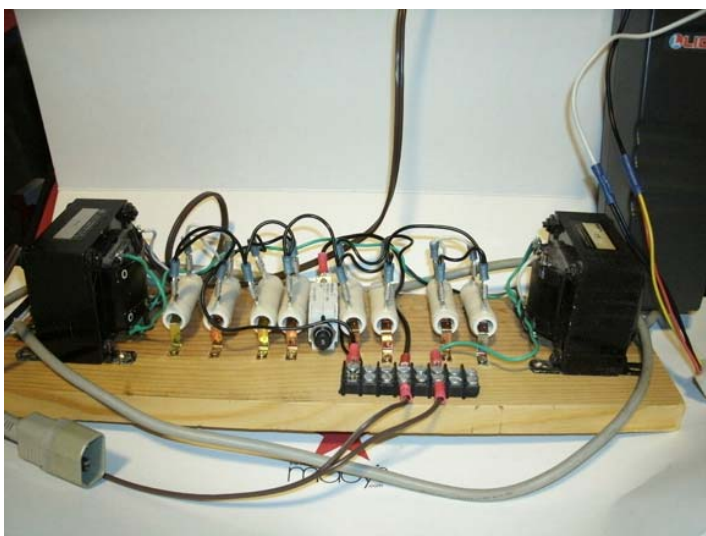

ured they would give me plenty of power. Each transformer had a pair of secondary windings capable of putting out 18 volts at two amperes. By paralleling these windings, I had a total of 18 volts and a fantastic eight amperes. However, you must take into consideration that there might be minute differences in the voltage output of the windings, so you do not wire the transformer windings together without putting in a little voltage dropping resistance.

Since I was wiring together four distinct secondary windings, each capable of two amps, I wanted a satisfactory power resistor on the high side of each sec-

MTH Lionel Ross Athearn Walthers Floquil Woodland Scenes Plastruct

ENGINE HOUSE HOBBIES

enginehousehobbies.net

Trains and more serving your creative needs
A Releasing Your Unlimited Creativity Application.

301-590-0816

1-A East Diamond Ave

ken@enginehousehobbies.net

Gaithersburg, MD 20877

Catoctin Mountain Trains & Hobbies

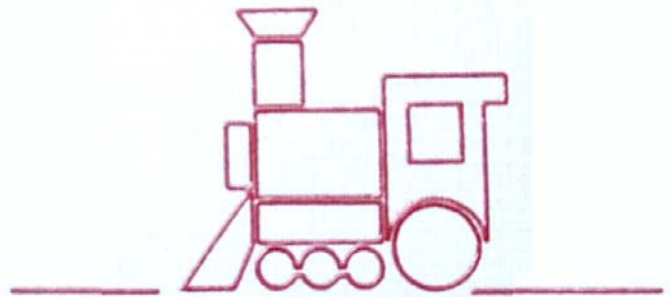

LIONEL TRAINS • FINE 0/027 TRAINS FROM MTH

Telephone: 301/271-5491

Fax No.: 301-271-5427

trainspj@aol.com

www.cmtrains.com

PAUL & MARCIA JOHNSON

3 West Main Street

Thurmont, MD 21788

ondary winding. This is figured out by calculating the power required by multiplying the voltage times the current ($P=E*I$ or $P = 18 \text{ V times } 2 \text{ A}$, or 36 watts). The next step was to figure out what resistance I wanted

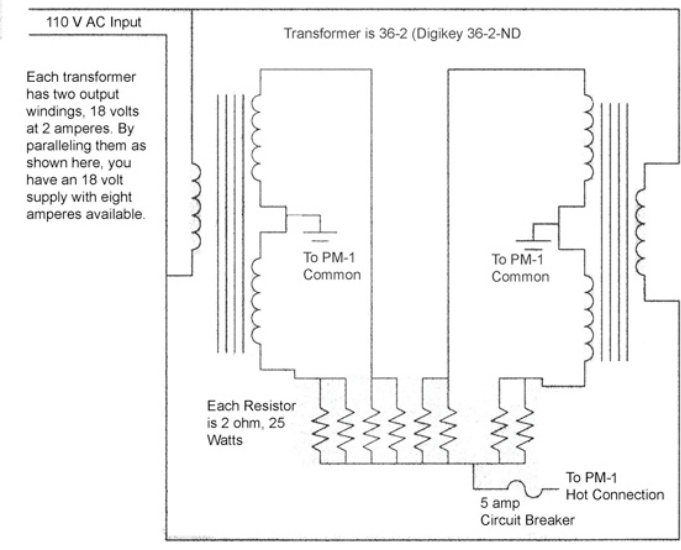

dropped over the resistor if I was drawing high current from the transformer secondary. Using the formula for Voltage (E), this is figured by multiplying Current (I or 2 amps) times the resistance (R desired to be one {1} ohm), giving me a maximum voltage drop of two volts when the transformer is supplying its maximum current. My resistance I wanted was one (1) ohm at the proper wattage (36 watts) to easily protect the transformer windings if there was a difference in the outputs, so I went looking for one ohm resistors at AllElectric.com. Bummer, they did not have one ohm resistors in their catalog or on their web site. However, I found two ohm, 25 watt resistors there. I also wanted to purchase a five amp AC panel meter at the same location, so I went for meter and eight each two ohm 25 watt resistors. By paralleling two each two ohm resistors, I wind up with a one ohm load that will dissipate 50 watts of heat if the full two amps are pulled from each secondary winding. This would mean that the voltage applied to the track would only be 16 volts instead of 18, but it should not stop any engine and train on the tracks.

The panel meter was to go into a voltage-current form I was setting up as well, so I got what I needed. After wiring the primaries of both transformers so they would have the hot and neutral on the same post, I then connected the common side of the four transformer secondaries. I used a voltmeter to make sure I did not have a mismatched winding and that the transformer outputs were in phase, I then connected two parallel two ohm resistors to each 18 volt hot line. (What you see in the picture between the

two black transformers is the bank of two ohm resistors.) Once all eight resistor outputs were wired together, I ran the connection to a five amp fast blow circuit breaker that is mounted between the banks of resistors. That then connects to the input of the Power Master-1.

In order to simplify the connections, at this point I pulled out the wiring from a dead computer power supply (of which I have legion), and connected it to the output of the Power Master. I have the mating connection attached to the voltmeter/ammeter box and ultimately the tracks of the railroad, making this a true plug-and-play assembly.

Following addressing the PM-1 from the Cab-1, and then spinning the red knob on the Cab-1 resulted with an operational railroad. The railroad ran my 1689 with its train for a while, then ran an 80 year old Ives train (where my three-amp meter was buried full scale), tested several other items finding one a direct short, another an open, an MTH Dockside I brought over later from my train supply, and the final item run was the main Swap Meet door prize. All operating units ran flawlessly, most drawing less than the three amps on the amp meter I had in-line at the time.

The final piece, the voltmeter-ammeter combination I had finally finished on November 1st, but only hooked up the voltage side is pictured below.





Bill Moss wins the Lionel Speeder door prize at the November Swap Meet.

Catoctin Mountain Trains and Hobbies Open House

On Saturday, November 9th, Paul and Marcia Johnson hosted a fun filled open house for the WB&A Chapter members. There was food, including sandwiches, cake, brownies, soft drinks, door prizes and great discounts on everything in the store for WB&A members! The day began with a few Chapter members meeting at the Kountry Kitchen in Thurmont for breakfast. After spirited discussion it was off to the train store. Paul also coordinated with Mike Hobbs, 3d generation owner of the local hardware store, for attendees to visit Mike's spectacular layout in the basement of his home down the street on East Main. Mike used every bit of available space to construct his layout with multiple levels running 11 separate loops of O Gauge post-war trains plus a Standard Gauge loop running around the perimeter of the basement. Back at the store, time flew by as everyone scoured the shelves for trains, accessories and model building supplies to take advantage of the fantastic discounts available to WB&A members. Sadly, as 4PM was approaching and purchases were being loaded into vehicles everyone realized a great and fun day was coming to a close. A big THANK YOU goes out from the WB&A Chapter and its members to Paul and Marcia for hosting a great

day of playing trains and meeting friends. Paul and Marcia will host another event for the Chapter in February. Once the date is firmed up we will let you know.



The WB&A Troops invade the Catoctin Mountain Trains and Hobbies Open House. (Dave Eadie, Bill Moss, Tom Salen, and Glenn MacKinnon)



Steve Salen enjoys Mike Hobbs' layout in Thurmont, MD.

OUR NEXT STUDY GROUP is JANUARY 25, 2014 at 5233 Bessley Place, Alexandria, VA,

Topic: Lionel Prewar Stations and Power Houses, O and Standard.

We will start at 10 am and conclude at 2 pm. Lunch is provided.

Together we will study and learn more about these fascinating buildings. In the Classic Era, Lionel offered at least eight different sizes of passenger stations and platforms and at least four different sizes of power stations. Lionel frequently changed colors and features. Some Lionel stations and power houses were even labeled for the Ives division of Lionel. If you have stations or power houses, please bring them. If not, please come anyway. Share your Saturday with others who love Lionel trains.

Clem Clement and Bruce Greenberg

For more information, please call 703-461-6991.

LOCO DOCTOR AND THE KIDS

I understand loco in Spanish means crazy. I understand it means the same in English. Doctor means to fix, to practice the art of healing. So if I were crazy to fix trains, so be it. Our motto is "we fix memories."

A little fellow came up to our repair table and could barely see over the table. He struggled with his courage and then asked in a wobbly voice, "Can you fix my train? It's broke!" He gingerly hand his prize loco to THE MAN: The late Bobby Tufts. Mr Bob looked at the little boy with loving eyes and begins to draw the story out of the youngster. No work was done until the owner had told his story. Ya see, Mr. Bob was a magic man and to do magic just right, he needed a story. Seems the boy's sister or puppy had wronged the loco, certainly not the boy (:>). The tired loco was laid in a special cradle and Mr. Bob's skilled hands passed over the metal parts while talking all the while to the boy about trains and who busted this and life in general. The boy's eyes never left the beloved engine watching that Mr. Bob carefully handled his friend. A loving father watched and listened as well. Because when you talked trains with Mr. Bob, you talked about lots of things that Daddy's want to hear about. Some-time little ones will tell Mr. Bob secrets that they would not share with Daddy's so we all listened close while the MAGIC ONE preformed. The loco also spoke to them. "Too much goo here and there, tinsel around my axles, Boss you left PBJ on my front, someone ouched me here and so on." Oil came and a cleaning and repairing came and then the magic hands of Mr. Bob set the loco on the test track. Everyone held their collective breaths and the little one gave his loco some power...AND OFF IT WENT. Mr Bob shouted its "alive; it's alive." Something got in my eye about that time and thru the blur I saw the Face of God displayed in that little boy and his Daddy.

Mr. Bob is fixing trains for the Lord now and we know he continues his magic.

Mr. Bob found out about the train weekend planned a round the restored railroad station in Rich-

mond VA. Some how he wheedled us in as loco doctors. Katherine was the Director of Development and full of energy and new ideas. She set up quite an affair. The lower floor had seven running train lay-outs. The upper floor, the grand entrance area had dealers and I forget what all. We loco doctors were right near the entrance. We piled lots of repair parts, tools, lights, and support equipment and headed to Richmond Friday night. Bob got us a good deal in a fleabag hotel someplace.

Saturday early we set up and had no idea what to expect. The doors opened and the crowds poured in. What an exciting two days of fixing trains and talking to folks. There was a local train shop guy there as well and he set up near us. His plan was to take the business in and to promote his shop. I think he was not happy with us being there but he was gentleman enough to not say so. You see, we fix for nothing and only charge if parts are needed. This is one of our give-backs to this wonderful hobby. So we are afixin and a yakin and laughin with all and the fellow quietly says to me "I can't do this. I get nervous fixing in front of people. I have never done this. I always do repairs in the privacy of my back shop." Well, we ain't having none of this...because repairing and talking to the owner is too much fun. About that time a fellow brings in a search lite that needs a wire soldered in place. Mr. Bob sets the guy up with the soldering iron and a cradle for the car and asks can you do this job? Sure is the answer. Bob sez, take a deep breath and go for it. The wrinkled hands move deliberately and slowly at first, and the skills begin to show. The owner asks a question and the answer comes weakly back. The next Q brings a stronger answer. Bob and I get busy with our tasks and don't look over for a few minutes. Upon doing so, the guys is talking a blue streak cleaning the car and grinning from ear to ear. Another convert to the Loco doctor world. He fixed happily for 2 days, and gained several big projects as well to take back to his shop.

Try it, you will like it. If you aren't comfortable with repairing, join someone who is. Help is always needed in dusting off the trains, organizing the order of repair, and listening. Wow, the experience is rewarding! For us, we don't take \$\$ but encourage the owner to leave something in the till of the location we are supporting.

I make a list of the parts and supplies I need and then lose the list every time. Simply, your favorite cleaning supplies, a good soft paint brush, a good light, power supplies both AC and DC. Lubricants and rags and Que tips as well. (I don't work on digitized trains so I don't take hi tech equipment. Hi tech pieces really need a hobby shop's test equipment and

Advertise in "The Trolley"

Send a check or money order payable to **WB&A** with your print ready AD to:

Paul Pullen
WB&A Newsletter Editor
8120 Candle Ln
Baltimore, MD 21237-1513

Ad Size	Per Issue	Year
Business Card	20.00	60.00
Quarter Page	30.00	100.00
Half Page	60.00	200.00
Full Page	125.00	400.00

space.) Support your local Hobby shop. At a recent Doctoring we sent 5 customers to the local shop because they did not bring their trains to the event. We bring some of the picture books such as the Greenberg series so visitors can point to the trains of their youth. This Loco Doctoring is about way more than fixing tin. It is about memories and families and warm spots on an oldster's mind. It is so much fun when asked about an old train at home: how big is it? Huge, huh? Does it smoke? Does it have knuckle couplers? What color is the engine? Many times after about the 4th question we can tell or owner what cars he/she has and what the loco is and point it out in a book. They are amazed. I always bring different trains in different gauges from home so folks can see then for comparison to their own trains from long ago.

Many times folks will ask about our cleaning supplies and tricks. What do you use for cleaning track, how do I clean an old toy at home? What oil do I use? Expect to wear out your tongue talking as well and your fingers fixing. Yesterday a fellow wanted a cleaning pad (The 6" squares of green fibrous pads from a hardware store.)

You will find that a crowd will always gather at the repair table. Watching and asking questions. A lot of kibitzing as well on all subjects unrelated to anything.

One time a fellow brought us a porcupine to fix. Wow that thing was a mess. He had decided that the track on his old layout was a bit rusty, so he scoured it with pads of steel wool. Then he fired up his Lionel #726 with magnatraction and ran it a few laps, after which it quit. Wonder why. The loco had all the steel shavings in the motor stuck to the magnets. That engine went home with a fellow loco doctor and it took hours to pick out the bits and piece with a set of tweezers! We do have a fixer- Dave Greenacre who loved the N and Z gauge trains. A lady brought us a dead N gauge loco that I could hardly see. Dave pops the top and with his bare eyes has a look. Her digs out his tweezers and removes a single cat hair. He sez to the customer "you have a grey Persian, don't you" The lady is stunned. He removes the single hair and the loco runs fine. I kick his butt afterwards in general principles because he is so good at repairs and has such great eyes. (Sadly I wish I could watch him again but he too is fixing the Lord's trains.)

There are a 29357027935 ways to have fun in this hobby. This is one that maybe you should try. For some reason kids and all keep playing with their trains so fixing tasks will be around for a long time. Clem Clement

CLEANING TRAINS

By Clem Clement, TCA 64-987



Let me start this treatise by saying that there is no ultimate cleaning answer or magic process. Cleaning trains is a continuing learning activity as paints and surface coverings continue to evolve/age, and cleaning processes and chemicals change. I'm also finding the cleaners are local in production. Common stuff here may not be so somewhere else. I'm a tinplater and certainly no expert on plastic. And scared of modern paints am I. I don't work for any of the companies whose products I write about. Nor by not mentioning a product, does that give any negative tint. The comments herein are my own and do not represent the opinion of TCA.

As we get started, here's some basic rules:

Never put the cleaning material directly on the piece- put it on a rag/Q-tip, etc. Ever sprayed Oven Off on a plastic train thinking it was WD-40? I have.

DON'T BELIEVE ME! Test everything for yourself.

Over the 100+ years of painted and litho trains, many types of paints and surface protectorates have been utilized. The content of some commercial products changeover time as the company improves their products and some products change as they age in their containers.

Study the piece before you start. A good friend quickly dumped an Ives repainted cab in a bucket of driveway cleaner and watched as the cleaning agent ate thru the sloppy white repaint and then ate thru the original "John Wanamaker" signature stamp and 1923 factory IVES paint.

No one product cleans everything. I have come to find that sometimes my favorite hand cleaner attacks some Ives maroon and brown colors.

Before you start; study, study, study. Take a look at the piece and see what it had been thru during its life as a toy:

Is it a repaint?

Is it paint or plastic color or metal dye?

Has it been cleaned/repainted before? Who did it: an expert or a wannabe?

Is the paint flaking?

Is the dirt removable or is the surface stained.

Where did it live and where did it retire: i.e., Did it live in a house with a bituminous-fired home heater?

Lived in New Jersey?

Retired in a wet basement or in the hot attic? Was it wrapped in newspaper? Did it have a swim at some point?

The next question is why do you want to clean it? It may be the best it can be or so fragile that high tech cleaners of today will only degrade it. I have a few pieces that I think the providence would change if the patina was cleaned.

OK, you decide you want to clean the thing. Start with non-aggressive cleaners and work up in strength. Don't start with kerosene, auto gas or alcohol. Start with a soft brush and work the loose dust and debris off. Camera stores have brushes with a bulb attached. You can brush a little and then blow the dust off. Re-attach anything that is loose. Trim moving around during cleaning can really chew up the paint on a piece. In my house we haven't directly thrown away any old tooth brush, ever. From its official job, it goes thru the dishwasher and to its real job of cleaning trains. Lightly, and then more harshly, clean under trim and around the piece. Be careful as decals and loose paint jump off under the scrubbing of a hard tooth brush. Be ever so careful when using a wooden tooth pick to dig junk out of corners. A one ounce push force on the tooth pick results in several hundred pounds pressure/square inch on the contact spot.

I like the Dremel rotary tool results, so that's where I go next. Safety glasses, please, then Dremel with a rotary wire brush the bright metal only where needed. Nickled wheels will shine up some. Post war sintered Lionel wheels will shed their goo but will take a false luster on the wheel sides. This is a giveaway to the knowledgeable collector when he is looking over the piece later. Tinned wheels will shine some but will not gain their original luster. Handrails, steps, journal boxes, etc. will give up their patina but be cautious. Lionel prewar bright trim was mostly coated with shellac or something to deter tarnishing. Dremeling this will shine the parts where the coating is gone, but will scuff the remaining coating. It may be better to keep the Dremel away and shine these parts with Symichrome or similar bright metal polish. Once you have shined brass, it loves to fade, so you have to recoat it or repolish it frequently. The discerning collector will note you have polished the bright work and take that into account. Some companies did not coat their brass well and it grows a lovely patina. Why not leave it? Also, be careful if you Dremel a number board so as not to rub the paint surrounding it.

I'm hearing success with Goof Off on train wheel tread electro goo. As the train wheels traverse the track they gather carbon, oil, and dirt. This goo can pileup significantly. On a power pickup up it can get so bad as to stop power from flowing into the piece. The goo seems to harden over the years and become more

nonconductive to electricity.

I'm against taking the train apart to clean the bright work. Just like this old man, I and the trains have only have so many shines and so much elbow grease left in us so why disassemble and risk tab failure/loss/etc.?

Symichrome does a nice job on bright work. Use a Q-tip or rag. It is fairly aggressive so be careful. Also shine the piece symmetrically. If part of the handrail demands work, do the whole thing. Then protect the bright work with a wax or Restorzit, etc.

I use a Lapidary tumble for my tin plate wheels. It really cheers a piece up to have the wheels shine like they did originally. I wrote the article in the TCA Quarterly on tumble use some years ago. The late Larry Batley and I worked on a test where we successfully shined some 10 series trucks with 1/8" rust pits. It took 100 hours of polishing and looks super. Blackened or sintered wheels will tumble, but they then need to be re-blackened. Removable couplers and trim will clean up well. Be careful to not wear the plating off or use too heavy a matrix. (Probably a subject for another article.) I don't drill rivets or disassemble tabs just to tumble the part. If it is fixed firmly to the car, leave it unless you are in a full resto job.

There is some interesting activity going on in home replating. For example, Eastwood sells kits for electroplating. <<http://www.eastwood.com/>>

Basic car cleaning is next. Be unaggressive!

The first time I watched a German friend clean a 1914 Marklin Gauge 1 mail car, I was stunned. He used soap and water and a scrub brush. I was sure he ruined it, but the dirt came off and the car dried beautifully. Turns out Marklin was the best at painting trains way back when. Their paint really sticks on the metal and is quite durable (With some exceptions due to unsavory storing or rough use.) However know what you are doing if you use water. Use a soft brush, warm water, very mild hand soap and immediate drying. Then let the piece sit on a register if not too hot or outside if not too sunny/hot. It must dry thoroughly to include under the seams and in the nooks and crannies. The dangers of this process:

Some Lionel paints will turn white with any contact with water. The Lionel color Mojave watermarks easily. Actually, I understand it is tiny flakes of paint turning up and showing underneath. This dullness can be rubbed out, but there goes your paint thickness and paint on rivets and decals. Some post war colors go immediately down the drain. Several of the colors in the lettering/numbering on heat stamps are a dye and when water hits them they washout. Many collectors will tell you to stay away from water cleaning. I say use the technique, just know what pieces can stand water.

A fun question to ask is what's on the piece. Surely as a kid, you gave your peanut butter and jelly sandwich a ride sometime. Brussels sprouts probably rode as well.

Some of these trains were played with by children, so no telling what they had on their hands. I've seen some heavy jelly collections in a gondola. Watch out for candle wax. It looks easy to pick off with your finger nail, but it hit the car hot and may have cooked the paint underneath. Work it off slowly with hand cleaner. Pre-war Christmas tree snow is horrible. I had a Lionel 214R that was lovely but the top had been hit by the fake snow. Nothing removed it as the spray ate into the paint surface.

Here's the prime stuff I use: Lanolin hand cleaner without abrasives or perfume. The more it smells like sheep, the better it is. Always check and test first. Put it on a rag/Q-tip not directly on the piece. Rub on and off at one time. If a ridge of cleaner is left remaining, it might discolor the paint. It happened to me only once but who knows. The GOJO cleaner from Pep Boys seems to pull dirt thru decals. I can't imagine how but I've seen it do it. Use Q-tips for the tight places. Wipe the piece off frequently.

I'm hearing that window cleaner without ammonia works well to clean Flyer plastic. Test carefully.

For litho jobs, I use hand cleaner lightly. Then add machine oil or linseed oil to the piece. Some litho has a white substrate that you can rub into. Consider marking pens to touch up if you can find the right colors.

Now the contentious step- to wax/shine/oil or not. I have a friend that uses Wahl's chipper oil on his tinsplate including the track. Looks beautiful and lasts a couple years. His is not a dusty environment. Some use DuPont #7 to both to shine and protect. It is a good product for your car, but not trains-too aggressive for me and if not completely wiped away, dries and leaves a white powder in the cracks. The best polish/wax for trains is Polific. It is made in Germany and very slow to cut paint (low pumice content.) It is hard to find.

I'm not a fan of Bravo. It was a tough floor wax that will leave a shine on anything. I saw a collection once that had Bravo on everything. Shiny orange suede trucks are something to see. As far as I know, Bravo won't come off.

Arguments for and against oiling the paint rage on. Oil gives a false shine and hides blemishes, but catches dust and may lift decals and window gelatins. Anyway, who knows what is in auto oils nowadays? The additives may munch your surface while the oil is protecting it. There was a famous auction in Vermont one time where every piece had been drenched with light oil that actually dripped from the pieces during the auction. I bid 2 quarts.

Oh yes, if you mess up and spray a piece with tough stuff like auto brake cleaner, just set it on its wheels and go for coffee. That stuff is fast. If you leave it alone, it may evaporate with not too much damage. I was in a big rush on a post war plastic loco and squirted brake cleaner on the motor and the body after picking up the

wrong spray can. The plastic started to wrinkle and the paint to soften and run. Two days of drying helped some and then some WD-40 helped a little but never fully recovered. We've talked about WD-40. Good stuff, but be cautious. It will leave a film after it dries. It also smells for a period. (At one of the outside gatherings at York, after one hour in the sun on the first morning you could smell the fresh cleaners and paints burning off their vapors in the sun!). I clean motors with Radio Shack black and white TV Tuner cleaner. It's expensive but it will chase out petrified oils. The older Radio Shack stuff was better and much cheaper, but it was harmful to the environment.

If the motor is hopelessly rusted, try an ultrasonic cleaner. No plastic or paint. We saw a Flyer loco dropped in ultrasonic solution and buzzed. Instant melt down.

Caution. I don't know much about modern paint and for that matter, high tech cleaners. Test thoroughly before cleaning a China-made Williams piece with Simple Green, for instance.

Hair dryers are good for removing plastic tape from trains and from boxes. Be careful with the heat. Some of the tough cleaners of the past are gone. For instance, Oakite, old MMO formulas, and others. They might have been good for their purposes, but hard on the environment and human health.

To remove newspaper stuck in train paint takes time. This one is a slow job. Apply thin oil to the paper and let it soak in for several days. The paper will turn opaque. Then rub the paper with your thumb using medium pressure. Layers of paper will roll off. You can drag your thumb nail across the paper to scrape more off, but not too much at each time. Re-oil and do it again. The paint underneath the paper is damaged, so go slow. The last one I did took a month but 90% of the paper came off. When finished, protect the damaged paint.

I have 706 pet theories about train paints and their present condition. You get two of them here. I believe the air surrounding the train might have changed the color of the piece. I have a Lionel 514R refig that is light tan on the outside and white on the inside. There are many samples of this paint that have been found on the 514R and the 515 Tank that have a light tan hue.

Were all white to begin with? Could it have been bad paint mix, dirty equipment, intentional, etc.? I think the atmosphere the car lived may have helped the color change. If the air around has a higher sulfur content (from coal burning heaters,) then sulfur oxidants were present. These molecules are ugly and leave their mark on bright metal. Since my sample is white on the inside and tan on the outside, did the sulfur, or whatever was in the air, change the color? I have 6 of these cars with the color changed and all have the tan in the same shade around the car, so sunlight on one side is ruled out. Another theory, based on the sev-

eral sets with grime really imbedded in the paint is that those trains retired in a basement with coal dust. No more theories today.

I'm not a fan of waxing the trains. Some waxes change color over the years and some harden so I stay away from them. I'm lucky in that my trains live in a climate-controlled room and don't have to ward off moisture, heat, etc. I am near Washington, DC, however so maybe I'd better protect them from the politico blow. Maybe someone would like to contribute info on good wax products.

Guardman Furniture polish comes in a gray plastic squeeze-me bottle and is reported to be great for shining plastic and metal cars.

Another thought—if you have a particularly dirty piece, try this: Clean it as mentioned herein and then wipe with Wahls or another light machine oil. Let it sit for a month or so and clean it again. I have pieces that I cleaned this way once a month for 6 months and still got dirt to come off.

Hair dryers are good for white plastic "Mold". Remember the best cleaning secret of all: When your significant other is out of the house, set your dirty train hat/cap in the top drawer of the dish washer. Prop the brim/lip with clean dishes, and let 'er rip. Dry outside. Some how I've never heard of a companion, who approved of such a process, so don't get caught!

There is a lot of material here. I hope it helps and sparks discussions. Please tender your comments.

Please realize that neither I nor TCA represent any of the products mentioned herein. The opinions are mine and shared for the hobbyist's consideration and info only. Please don't send my words to some manufacturer who I may have not properly lauded. Their

help is most welcome, however. Test everything carefully and remember that safety is paramount. Keep hazardous materials away from children and in safe storage.

There are many questions that need further research and other fine products that need a review. If you have comments or more information or ideas, please contribute to E*Train for an updated story. Here are some of the questions I have not treated:

How to remove spot mold on post war plastic diesel tops?

Use of tooth paste in cleaning?

Use of an air compressor in cleaning trains

Can ATF be used safely as a cleaning agent?

KD offers a track cleaning compound. Good Stuff?

Soaking dirty train trucks in WD-40.

Removing various types of adhesive tapes from boxes/trains.

McQuires offers a new brand of liquid to remove swirls from paint finish. Does this work on trains?

Do silicon cleaners create silicates which have sharp edges and can damage paints/humans?

Use of Cox model airplane engine fuel as a cleaner?

Is there a simple way to remove the black goo from train wheels? So far most folks "shave" the goo off with an Exacto knife and end up with a very black thumb from the goo.

How to remove old dried linseed oil?

What are train plastic bodies made up of: Styrene, acetate, tenite, etc. What are their reactions to cleaning methods?

Which plastics can stand ultrasonic cleaning?

Are there no-nos in cleaning trains? Such as the use of auto gas or diesel fuels as cleaners.

Safe use of lighter fluid?

How to clean litho jobs?

What cleans rubber tires on modern locos?

How to clean trains of the current productions containing modern paints and materials.

Tell us a story about your most successful cleaning of a train.

Enjoy.

clem.clement@cox.net

WB&A Board of Directors Business Meeting

When: January 25, 2014

Where: Tom & Susan Salen

412 Center St. North

Vienna, VA 22180-4109

Time: 9:00 a.m.-1:00 p.m.

Agenda: Minutes, Treasurer's Report, Eastern Division Report, Old Business, New Business.



Lionel Trains

Don Borneman



6309 Dewey Dr.
Columbia, MD 21044

410-730-1798
hotsho2go@aol.com

STANDARD GAUGE STUDY GROUP: Lionel Nos. 125 and 126 Stations, Ives No. 226 Station

Beginning in 1920 Lionel introduced its own line of stations. The first was the No. 124 "LIONEL CITY" which was also sold with different features as Nos. 121, 122 and 123. In 1923 Lionel introduced the smaller "LIONELVILLE" station in two versions, No. 125 without an interior light and No. 126 with an interior light. The No. 125 was only offered through 1925 while the No. 126 was offered through 1936. Lionel and American Flyer as owners of Ives sold the No. 126 station as Ives No. 226.

What is the basic construction of the No. 126? The station has a base, four sides and a roof. Are the four sides composed of four side pieces plus windows and door trim? Or did Lionel build the stations from a side and an end as with some freight cars? From our study we learned that the stations were constructed with four sides.

How were the sides assembled? Where they soldered, tabbed or some combination of tab and soldering? How was the base attached? From our study we learned that the sides were fastened only with tabs and that the sides and base were fastened only with tabs.

Did Lionel change the construction and assembly during the production period? From our study we learned that the station construction and assembly did not change. However the decoration and lettering changed.

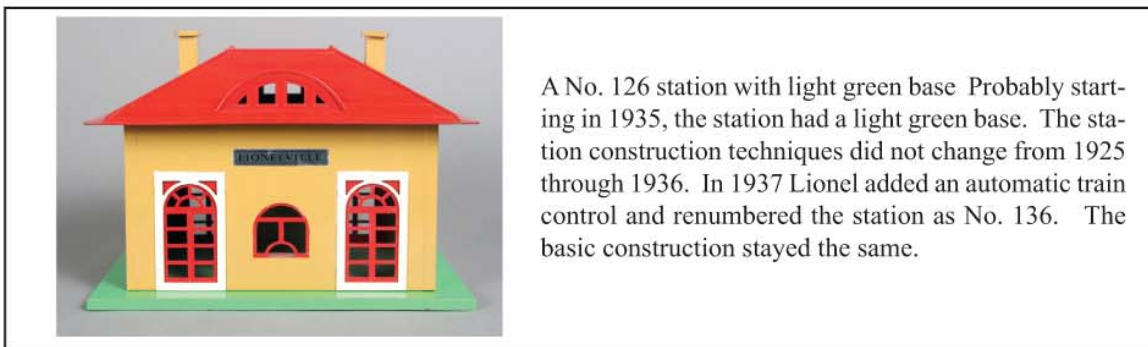
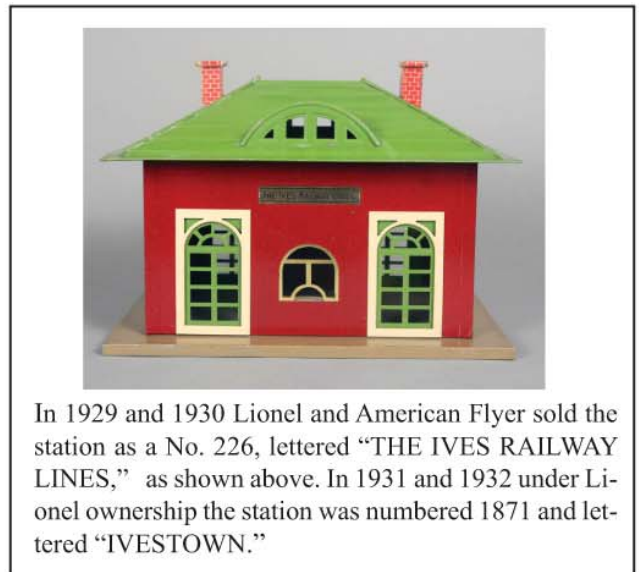
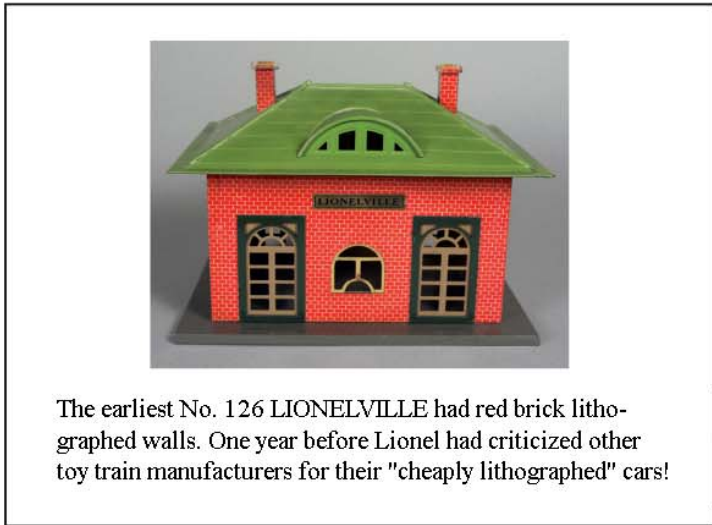
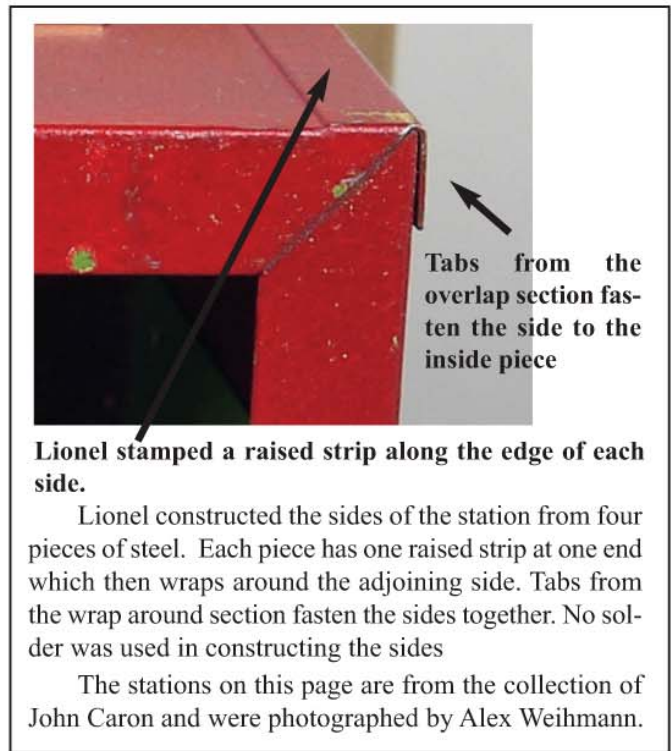

MARK YOUR CALENDARS

Annual WB&A Train Show & Sale

Saturday, March 15, 2014

Annapolis Armory

18 Willow Street

Annapolis, MD 21401

9:00 a.m.—2:00 p.m

- Open to the Public at 9:00 a.m.
- Old and New Trains for sale.
- Great door prizes for adults and children.
- Train Layouts featuring Thomas the Tank Engine.
- Catered food.
- Free Parking.
- Free Train Appraisals.
- Train Repairs and Parts Dealers.

For information, contact Art Tate (acttoo@aol.com) or 410-766-9150

Hope & Dan Danielson invite you to their NEW TOY TRAIN STORE Toy Trains & Collectibles

New & Gently Used Electric Trains

Lionel, MTH, American Flyer, Williams

HO & N Gauges, too - Scenery & Accessories

Diecast Cars - Vintage Toys

Britians, Barkley, Manoil Dimestore Figures



Train Repairs on Site

7216 New Market Court

Manassas, VA 20109

We Buy Trains

571 379-5497