

CVS Series D Globe and Series DA Angle Style Valves

Introduction

Contained in this manual are installation instructions, maintenance procedures and parts information for the 1-inch and 2-inch CVS Series D Globe and Series DA Angle Style Valves. Refer to the appropriate manuals for instructions for the accompanying actuator and additional accessories.

Trained or experienced personnel should carry out operation and installation of all pressure equipment. If you have any questions regarding the equipment, contact your CVS Controls representative.

Applications and Features

The CVS Series D (figure 1), CVS Series DA (figure 4a) is a single port, screwed-in metal-seated valve with unbalanced post-guided valve plug, and push-down-to-close plug action used for high pressure applications. These valves are used in the oil and gas industry, and are especially useful for throttling or on/off control of liquids or gases, providing excellent pressure and flow control of steam, gasses, and various liquid processes.

The flow characteristic of the Series D is equal percent and flow direction is up through the seat ring and past the valve plug. Flow direction of the Series DA is flow in either direction. The Series D valve is available in 1-inch and 2-inch sizes, with cast integral flanges, welded flanges, screwed, flat face or socket weld connections. Series DA Angle Valve is available in 1-inch and 2-inch sizing, with welded flanges, screwed, flat face or socket weld connections.

The valve plug and seat ring can be fitted with tungsten carbide inserts or stellite overlay. Please contact your CVS sales representative for availability and delivery time.



Figure 1: CVS Series D Globe Valve with CVS 667 Actuator and 4150 Controller

Sour Service Capability

Optional NACE MRO175/ISO 15156-2009

CVS Series D Valves are available in the following body materials - LCC, WCB, WCC, WC9, C5, Monel, and CF8M SST.

End connections are ASME B16.34-latest edition Class 150 through 2500. Cast integral flanges, welded flanges, screwed or socket weld connections available for the Series D. Series DA are available with welded flanges, screwed or socket welded end connections.

Trim material is available in 316SST, 416SST, Alloy6-Co.Cr-A, Ceramic, Cobalt and 316SST/Tungsten Carbide.

Additional materials may be available upon request. Please contact a CVS Controls representative for more information.

Specifications

Maximum Inlet Pressures and Temperatures¹		Refer to the valve nameplate. If the nameplate shows an ASME pressure-temperature class, the maximum inlet pressure and temperature is consistent with applicable ASME class per ASME B16.34-latest edition. If an ASME class is not shown on the nameplate, it will show a maximum cold working pressure at 38°C (100°F). For example 3600, 6000, 9000 or 10,000 psi.
Maximum Allowable Pressure Drops		Capable of full rated pressure drops
Shutoff Classification per ASME/FCI 70-2	Standard	Class IV leakage
	Optional	Class V
Maximum Service Temperature		232°C (450°F)
Flow Characteristic		Equal percentage
Flow Direction, Series D		Flow up, through seat ring and past valve plug
Flow Direction, Series DA		Flow in either direction
Approximate Weights Refer to Table 4 for details	1-inch	34 kg (75 lbs)
	2-inch	45 kg (100 lbs)
<p>1. Pressure and temperature limits as listed should not be exceeded. Industry standards should also be strictly followed.</p>		

Installation

Warning

CVS Controls recommends the use of protective clothing, gloves and eyewear when performing any installation or maintenance.

Installation of the valve assembly under conditions which exceed the limits outlined in this manual or on the nameplate may result in personal injury. Overpressure may cause sudden release of process pressure or bursting of assembly parts.

The valve configuration and construction materials of each assembly are specified during ordering to meet specific pressure, temperature, pressure drop and controlled fluid conditions. Do not operate any part of the assembly outside of those conditions without first contacting CVS Controls.

1. Before installing the valve, inspect the valve body cavity for foreign material.
2. Remove all foreign materials such as scale or welding slag from all pipelines.
3. Unless limited by existing seismic conditions, the control valve assembly may be installed in any position. The normal method is with the actuator vertical above the valve.
4. Install the valve so the process flow coincides with direction shown by the arrow on the valve body.
5. Use accepted piping and welding practices when installing the valve in the line. For flanged valve bodies, use suitable gaskets between the body flanges and pipeline flanges.

Note

Post-welding heat treatment may be required on some valve body materials. Avoid damage to internal elastomeric, plastic and metal parts by removing all trim. For more information, contact your CVS Controls representative.

Installation cont'd

6. For screwed end connections, apply pipe compound to pipeline threads.
7. Install a conventional 3-valve bypass around the body to allow for continuous operation during maintenance and inspection.
8. If your actuator and valve body were shipped separately, refer to the proper Product Manual for actuator mounting procedures.

Install bypass valves or completely shut down the process to isolate the valve from process pressure. Relieve all pressure and drain process media from both sides of valve.

Vent all pressure from the actuator and relieve pre-compression from actuator spring.

Use lock out procedures to ensure the process remains shut down during maintenance.

Check the packing box for pressurized process fluids even after the valve has been removed from the pipeline, particularly when removing packing hardware or packing rings, or removing packing box pipe plug.

Warning

Packing leakage could result in personal injury. Valve packing is tightened prior to shipping but may require readjustment to meet specific service conditions.

Maintenance

Warning

Personal injury may result from sudden release of any process pressure. CVS Controls recommends the use of protective clothing, gloves and eyewear when performing any installation or maintenance.

Isolate the valve from the system and relieve pressure prior to performing maintenance.

Disconnect any operating lines providing air pressure, control signals or electrical power to the actuator.

Depending on the severity of service, valve body parts experience wear and tear and must be inspected and maintained according to conditions.

This manual includes instructions for lubrication and maintenance of packing, trim maintenance and lapping of seating surfaces. All maintenance procedures can be conducted while the valve remains in the line.

Note

If a gasket seal is disturbed while removing or adjusting gasketed parts, CVS Controls recommends installing a new gasket while reassembling. A proper seal is required to ensure optimum operation.

Table 1: Bolting Torque for Packing Box Nuts (Key 2)

Valve Rating	Stem Diameter		Minimum Recommended Torque		Maximum Recommended Torque	
	mm	In	N•m	Lbf•in	N•m	Lbf•in
3600 or to Class 1500	9.5	0.375	4	36	5	48
	12.7	0.5	7	66	11	96
	19.1	0.75	16	144	24	216
6000 or Class 2500	9.5	0.375	5	42	7	60
	12.7	0.5	9	78	12	108
	19.1	0.75	20	180	30	264
9000 psi	12.7	0.5	6	54	8	72
	19.1	0.75	20	180	30	264
10,000 psi	12.7	0.5	6	54	8	72
	19.1	0.75	20	180	30	264

Packing Lubrication

An optional lubricator or lubricator/isolating valve (Figure 2) may have been installed in place of the pipe plug within the tapped bonnet. This is used for PTFE/ composition or other packing that require lubrication. Use a silicon-base lubricant. Packing used in oxygen service does not require lubrication.

Lubricator - turn the cap screw clockwise to force the lubricant into the packing box.

Lubricator/isolating valve - open the isolating valve before turning the cap screw to add lubricant, and close the isolating valve after lubrication is completed.

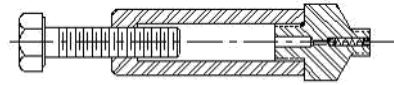

Lubricator

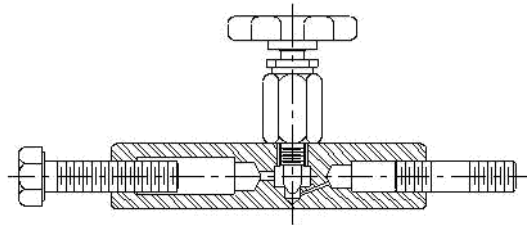

Lubricator/Isolating Valve

Figure 2: Optional Lubricator and Lubricator/Isolating Valve

Packing Maintenance

Contact your CVS Controls representative for specific packing orientation, composition and arrangements.

- For spring-loaded single PTFE V-ring packing, the spring (Key 16) maintains a sealing force on the packing. Stop leakage around the packing follower (Key 11) by tightening the packing nuts. If the shoulder of the packing box is touching the top of the bonnet and leakage cannot be controlled, please see "Packing Replacement."
- If there is packing leakage with other than spring-loaded packing, try tightening the packing flange nuts (Key 2) to the minimum torque value shown in Table 1. Do not exceed the maximum torque value shown in Table 1. Exceeding the maximum torque value may cause excessive friction to result.
- If the packing (Key 13) is relatively new and tightening the packing flange nuts does not stop the leakage; a worn or nicked valve stem or damaged packing box bore might prevent a proper seal. Follow the steps for Packing Replacement and inspect the valve stem and packing box wall during the procedure

Table 2: Torque for Bonnet to Body Joint

Valve Size (In.)	Recommended Torque	
	Lbf•ft	N•m
1	780	1060
2	1500	2030

Table 3: Torque for Seat Ring (Key 8)

Valve Size (In.)	Recommended Torque	
	Lbf•ft	N•m
1	300	407
2	515	698

Packing Replacement

Warning

Prior to performing any maintenance procedures, review the warning notes at the beginning of the Maintenance section.

1. Isolate the control valve from the line pressure, release pressure from both sides of the valve body, and drain the process media from both sides of the valve.
2. Disconnect any operating lines providing air pressure, control signals or electrical power to the actuator. Use lockout procedures to ensure the above measures stay in effect while you work on the equipment.
3. Disconnect the stem connector, and then remove the actuator from the valve body by unscrewing the actuator yoke locknut (Key 4).
4. Loosen the packing flange nuts (Key 2) so the packing is not tight on the valve stem. Remove travel indicator parts and stem locknuts from the valve stem threads.
5. Unscrew the bonnet (Key 6) from the valve body (Key 7). Carefully lift off the bonnet and plug/stem assembly (Key 19) as a unit.
6. Remove the plug/stem assembly from the bonnet. If you plan to re-use the valve plug, protect the plug seating surface and the stem threads to prevent damage.
7. Remove the bonnet gasket (Key 17).
8. Cover the opening in the valve body to protect the gasket surface and prevent foreign material from entering into the valve body.
9. Remove the packing flange nuts, packing flange, upper wiper, and follower (Keys 2, 3, 10, and 11). Carefully push out all the remaining packing box parts from the bonnet using a rounded rod or other tool that will not scratch the packing box wall or bottom guide bushing.
10. Clean the packing box bore and the metal packing box parts.
11. Inspect the valve stem threads and packing box bore for any sharp edges that might cut the packing. Scratches or burrs could cause packing box leakage or damage to new packing.
12. Install a new bonnet gasket (Key 17), making sure the gasket seating surfaces are clean and smooth. Carefully install the plug/stem assembly into the valve body. Then slide the bonnet over the stem and thread it tightly into the valve body, see torque values in Table 3.
13. Use the sequence shown in Figure 3 to install new packing and associated parts.
14. Slip a smooth-edged pipe over the valve stem, and gently tap each soft packing part into the packing box.
15. Slide the packing follower, upper wiper, and packing flange (Keys 11, 10, and 3) into position.
16. Lubricate and install the packing flange studs (Key 1), and nuts.
17. For spring-loaded PTFE V-ring packing, tighten the packing flange nuts (Key 2) until the shoulder of the packing follower (Key 11) is approximately 5/8" above the top of the bonnet.
18. For other packing arrangements, tighten the packing flange nuts (Key 2) alternately in small equal increments. Continue until one of the nuts reaches the minimum torque shown in Table 1. Then tighten the remaining packing flange nut until the packing flange is level and at a 90-degree angle to the valve stem.
19. Mount the actuator on the bonnet (Key 6) and connect the actuator and valve plug stem according to the procedure in the appropriate actuator instruction manual.
20. Check for leakage around the packing follower when you put the control valve assembly into service. Retighten the packing flange nuts as required.

Trim Maintenance

Disassembly

1. Remove the actuator and the bonnet as described in steps 1 through 3 of the “Replacing Packing” procedure.

Warning

The seating surfaces and surface finish of the seat ring (Key 8), stem (packing seal) and plug (Key 19) are critical for tight shutoff. Protect these parts from damage if you plan to re-use them in the valve.

2. Remove the plug/stem assembly (Key 19) and the packing parts from the bonnet.
3. If you re-use the valve plug, protect the valve plug seating surface and the stem threads to prevent damage.
4. Remove the packing parts as described in the “Packing Maintenance” procedure.
5. Use a socket wrench to remove the seat ring (Key 8).
6. Remove the seat ring (Key 8) and seat ring gasket (Key 9) from the valve body.
7. Inspect parts for damage or wear that would prevent proper operation of the valve body. Clean the gasket surfaces.
8. Replace trim parts as necessary or use the “Lapping Metal Seats” procedure.

Lapping Metal Seats

In any valve body with metal-to-metal seating, a certain amount of leakage should be expected. However, if the leakage becomes excessive, lapping can enhance the condition of the seating surfaces of the plug and seat ring. Deep nicks in the seating surfaces should be removed by machining rather than lapping.

There are many lapping compounds available commercially. Be sure to use one of high quality.

Apply the lapping compound to the bottom of the valve plug. Partially assemble the valve so the seat ring and valve plug are in place and the bonnet (with bushing installed) is screwed hand-tight into the body.

Make a simple handle from a piece of metal attached to the plug stem with nuts. Rotate the handle in opposite directions with light downward pressure to lap the seat.

Once lapping is complete, remove the bonnet and plug/stem assembly as a unit, and clean the seating surfaces, reassemble, and then test for shutoff. If leakage is still excessive, repeat the lapping process.

Assembly

1. Thoroughly clean the valve body gasket surfaces, seat ring and bonnet threads.
2. Apply Never-Seez Nickel lubricant or equivalent to the threads of the seat ring (Key 8), bonnet (Key 6), and their mating threads in the body.
3. Put the seat ring gasket (Key 9) into the body. Screw the seat ring into the body. Use a socket wrench to tighten the seat ring to the torque values shown in Table 3.
4. Clean the bonnet gasket-seating surface, and install a new bonnet gasket (Key 17).
5. If you had not removed the plug/stem assembly and packing from the bonnet, then install the bonnet (Key 6) and plug/stem assembly (Key 19) as a unit, into the valve body. To prevent galling ensure the seating surface of the plug does not contact the seating surface of the seat ring. Thread the bonnet tightly into the valve body; see torque values in Table 2.
6. If you chose to remove the plug/stem assembly and packing from the bonnet, then remove any protective covering from the plug/stem assembly (Key 19) and carefully install it into the valve body.
7. Slide the bonnet (Key 6) over the stem and thread it tightly into the valve body.

Assembly Cont'd

8. Use the sequence shown in Figure 3 to install new packing and associated parts.
9. Place a smooth-edged pipe over the valve stem, and gently tap each soft packing part into the packing box bore.
10. Slide the packing follower, upper wiper, and packing flange (Keys 11, 10, and 3) into position. Lubricate and install the packing flange studs (Key 1), and packing flange nuts (Key 2).
11. For spring-loaded PTFE V-ring packing, tighten the packing flange nuts (Key 2) until the shoulder of the packing follower (Key 11) is approximately 5/8" from the top of the bonnet.

For other packing arrangements, tighten the packing flange nuts (Key 2) alternately in small equal increments. Continue until one of the nuts reaches the minimum torque value shown in Table 1. Then tighten the remaining packing flange nut until the packing flange is level and at a 90-degree angle to the valve stem.

12. Mount the actuator on the bonnet (Key 6), connect the actuator and plug/stem according to the procedure in the appropriate actuator instruction manual.
13. Check for leakage around the packing follower (Key 11) when you put the control valve assembly into service. Retighten the packing flange nuts as required.

Parts Ordering

Each body-bonnet assembly is assigned a serial number, which can be found on the nameplate. Refer to this serial number when contacting your CVS Controls representative.

When ordering replacement parts, specify the serial number, key number, and part description, from the following Parts Lists.

Figure 3: Packing Arrangements

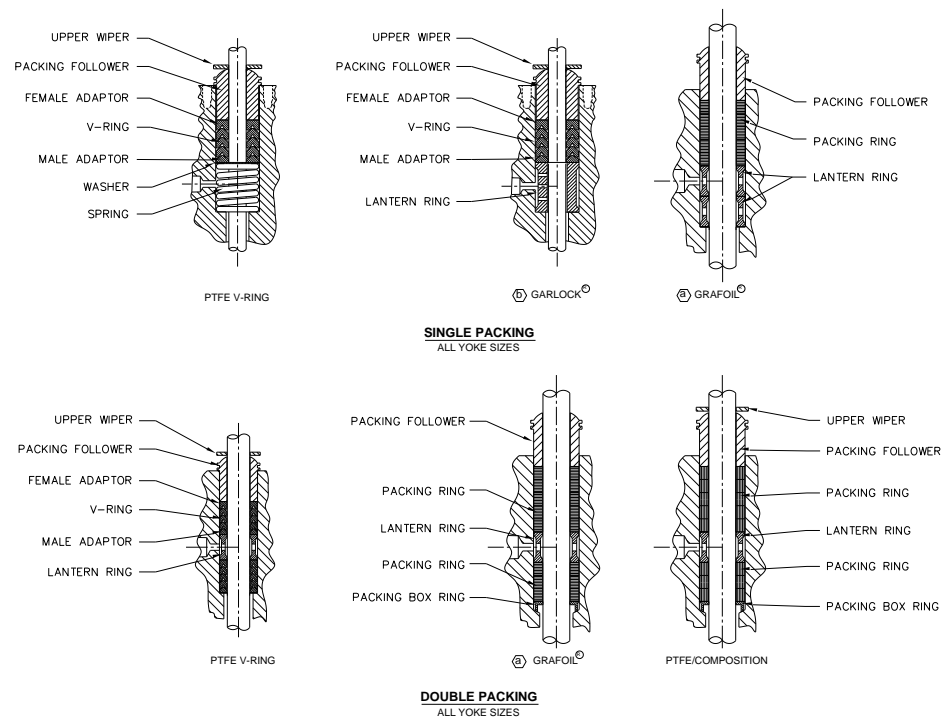

NOTES:

- ① GRAFOIL
- ② GARLOCK[®] IS A REGISTERED TRADEMARK FOR PACKINGS, SEALS, GASKETS AND OTHER PRODUCTS OF GARLOCK GARLOCK INC.

CVS Series D Control Valve Assembly

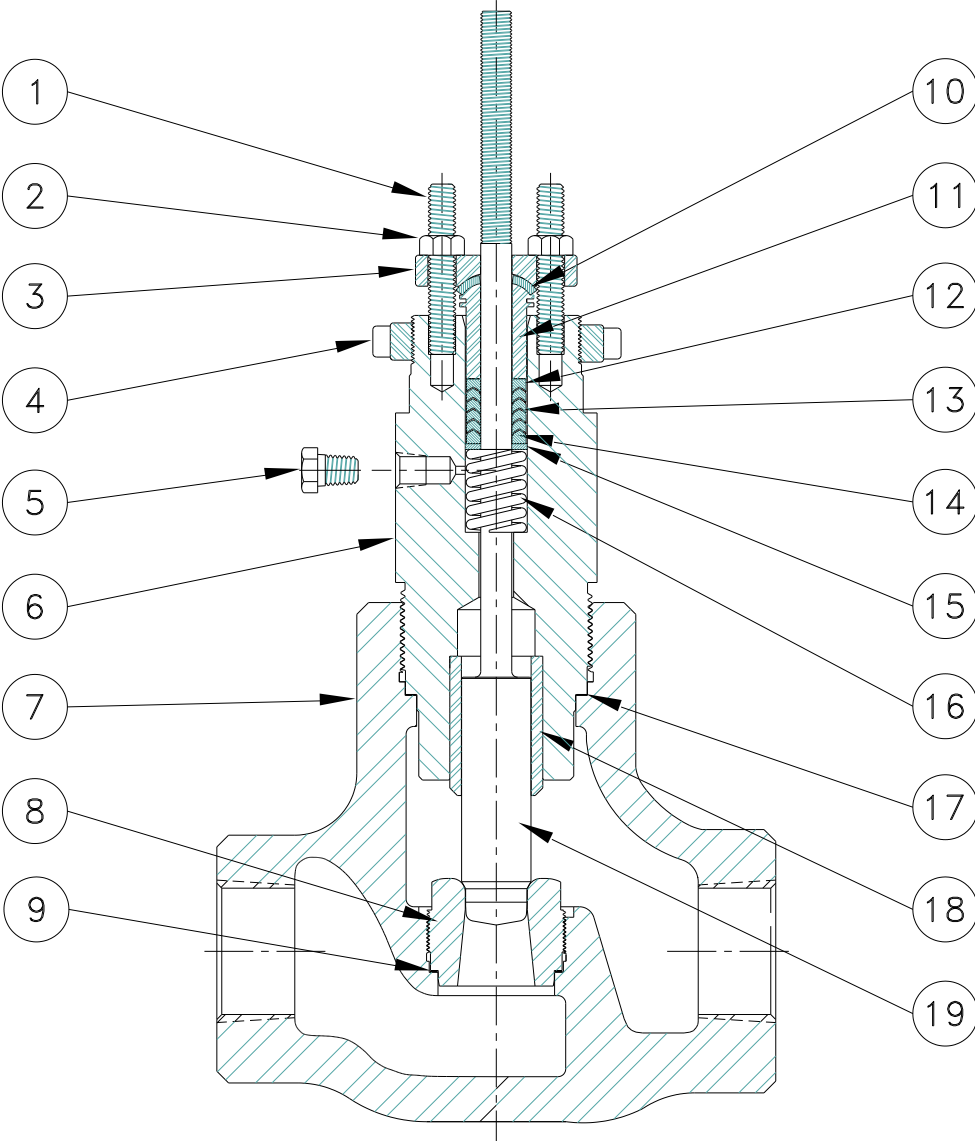

Figure 4 CVS Series D Globe Valve

CVS Series DA Angle Valve Assembly

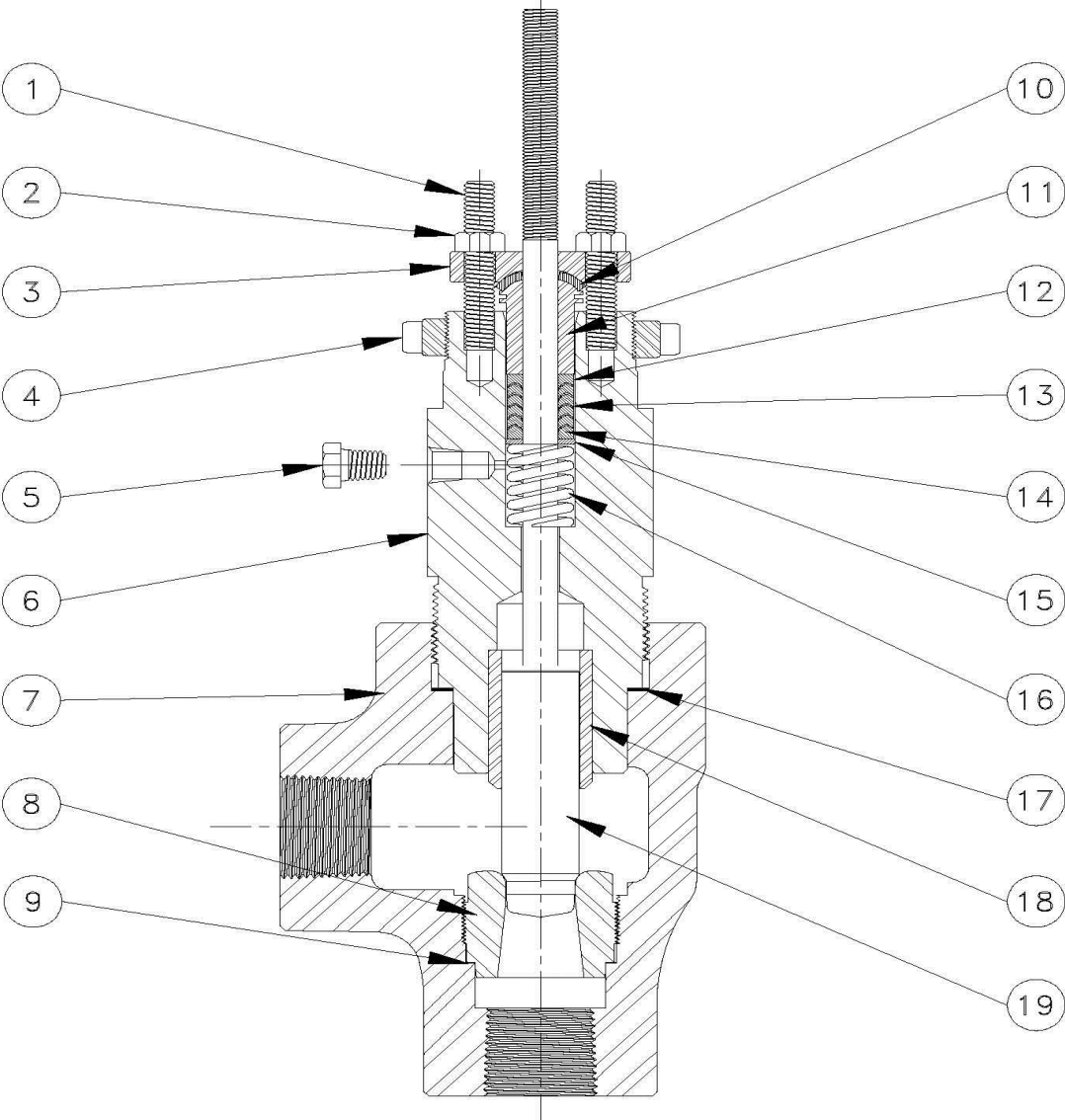

Figure 4a CVS Series DA Angle Valve

Parts List

Key	Quantity	Part Name	Material	Part Number
1	2	Packing Flange Stud Bolt – 2-1/8" Boss	Stainless Steel	CVS1E94413103
		Packing Flange Stud Bolt – 2-13/16" Boss		CVS1E94443103
2	2	Packing Flange Stud Nuts – 2-1/8" Boss	Stainless Steel	CVS1E94403103
		Packing Flange Stud Bolt – 2-13/16" Boss		CVS1E94453103
3	1	Packing Flange – 2-1/8" Boss	Steel, CD Plated	CVS1E94372410
		Packing Flange – 2-13/16" Boss		CVS1E94422307
4	1	Yoke Locknut – 2-1/8"	Steel	CVS1E79302306
		Yoke Locknut – 2-13/16"		CVS1E80742306
5	1 (optional)	Pipe Plug	Stainless Steel	CVS1A76752466
		Lubricator or Lubricator / Isolator	—	CVSAJ5428000A
6	1	Bonnet – 2-1/8" Boss, 1" Body	Stainless Steel / 4140 L80	CVS2F1383000A
		Bonnet – 2-13/16" Boss, 2" Body		CVS2F1432000A
7	1	Body – Consult your CVS Controls Representative for valve body, style, size and material availability		
8	1	Seat Ring – see following table Key 8		
9	1	Seat Ring Gasket – 1" Body	Mild Steel	CVS1B19862001
		Seat Ring Gasket – 2" Body		CVS1B19882001
10	1	Felt Wiper – 3/8" Stem	Felt	CVS1J1826
		Felt Wiper – 1/2" Stem		
11	1	Packing Follower – 3/8" Stem	Steel	CVS1E94393507
		Packing Follower – 1/2" Stem		CVS1E94433507
12*	1	Female Adapter Packing – 3/8" Stem	TFE	CVS1F12440101
		Female Adapter Packing – 1/2" Stem		CVS1F12430101
13*	1	Packing – 3/8" Stem	TFE	CVS1C7526000A
		Packing – 1/2" Stem		CVS1C7527000A
14*	3	Male Adapter Packing – 3/8" Packing	TFE	CVS1F12480101
		Male Adapter Packing – 1/2" Packing		CVS1F12470101
15	1	Washer – 3/8" Packing	Stainless Steel	CVS1F12523604
		Washer – 1/2" Packing		CVS1F12433604
16	1	Spring – 2-1/8" Boss, 3/8" Stem	Stainless Steel	CVS1F12543701
		Spring – 2-13/16", 1/2" Stem		CVS1F12553701
17	1	Bonnet Gasket – 2-1/8" Boss, 1" Body	Stainless Steel	CVS1B19822001
		Bonnet Gasket – 2-13/16" Boss, 2" Body		CVS1B19842001
18	1	Guide Bushing – 2-1/8" Boss	Stainless Steel	CVS1B16913501
		Guide Bushing – 2-13/16" Boss		CVS1B16923501
19	1	Plug and Stem – see following table Key 19		

**M-Flat trim available upon request, contact a CVS Controls representative for more information.

*Packing Set – Part Numbers	
Stem Size (in)	
3/8	CVS 1R2900
1/2	CVS 1R2902
3/4	CVS 1R2904

Key 8 Seat Ring

Body Size (In)	Orifice Size (In)		316 SST	316 SST with Alloy 6	316 SST with Tungsten Carbide
	mm	In			
1	6.4	1/4	CVS1B50973507	CVS1B50970012	CVS1J6886000A
	9.5	3/8	CVS1B50983507	CVS1B50980012	CVS1J6887000A
	12.7	1/2	CVS1B50993507	CVS1B50990012	CVS1J6888000A
	19.1	3/4	CVS1B51003507	CVS1B51000012	CVS1J6889000A
2	6.4	1/4	CVS1B51063507	CVS1B51060012	CVS1J6899000A
	9.5	3/8	CVS1B51073507	CVS1B51070012	CVS1J8154000A
	12.7	1/2	CVS1B51083507	CVS1B51080012	CVS1J8156000A
	19.1	3/4	CVS1B51093507	CVS1B51090012	CVS1J8158000A
	25.4	1	CVS1B51103507	CVS1B51100012	CVS1J8160000A
	31.8	1-1/4	CVS1B58013507	CVS1B58010012	CVS1P7421000A

Key 19 Valve Plug and Stem

Body Size (In)	Orifice Size		Stem Size (In)	Boss Size (In)	No. of Flutes	CVS Flute 316 SST	CVS Equal % 316 SST with Alloy Tip	CVS Equal % 316 SST with Carbide Tip
	mm	In						
1	6.4	1/4	3/8	2-1/8	1	CVS2N71470032	--	--
	6.4	1/4			2	CVS2N71480022	--	--
	6.4	1/4			3	CVS2F32800022	CVS2F13880042	CVS1J68940022
	9.5	3/8			3	CVS2N73890022	CVS2F31890032	CVS1J68950022
	12.7	1/2			3	CVS2N73380022	CVS2F13900032	CVS1J68960022
	19.1	3/4			3	CVS2N73930022	CVS2F13910032	CVS1J68970022
2	6.4	1/4	1/2	2-13/16	3	CVS2N71400022	CVS2F14270022	CVS1J81890022
	9.5	3/8			3	CVS27A87920062	CVS2F14280022	CVS1J81910022
	12.7	1/2			3	CVS2N73330022	CVS2F14290022	CVS1J81930022
	19.1	3/4			3	CVS2N62970022	CVS2F14300022	CVS1J81950022
	25.4	1			3	CVS2F32690082	CVS2F14310022	CVS1J81970052
	31.8	1-1/4			3	--	CVS2L53310032	CVS1V22340022

Table 4: Weights of CVS Series D Valve Body Assembly

Body Size	Weight	Class 3600 NPT	Class 3600 Welding	Welded Flange*			Short Body		
				Class 150RF	Class 300RF	Class 600RF	ASME 150RF	ASME 300RF	ASME 600RF
1"	Lbs	27.00	25.00	33.50	34.00	35.00	N/A	N/A	N/A
	Kg	12.25	11.34	15.20	15.42	15.88			
2"	Lbs	52.50	50.50	50.50	54.00	58.00	62.00	67.00	72.00
	Kg	23.81	22.90	22.90	24.49	26.31	28.12	30.39	32.66

* ANSI Standard Flanges only, welded Flanges

Body Size	Weight	Class 6000 NPT	Class 6000 Welding	Welded Flange*		Short Body		
				Class 900/1500RF	Class 900/1500RTJ	ASME 900/1500RF	ASME 900/1500RTJ	ASME Class 2500
1"	Lbs	N/A	N/A	45.00	45.00	N/A	N/A	N/A
	Kg			20.41	20.41			
2"	Lbs	105.00	103.00	N/A	N/A	98.50	99.00	142.00
	Kg	47.63	46.72			44.68	44.91	64.41

* ANSI Standard Flanges only, welded Flanges

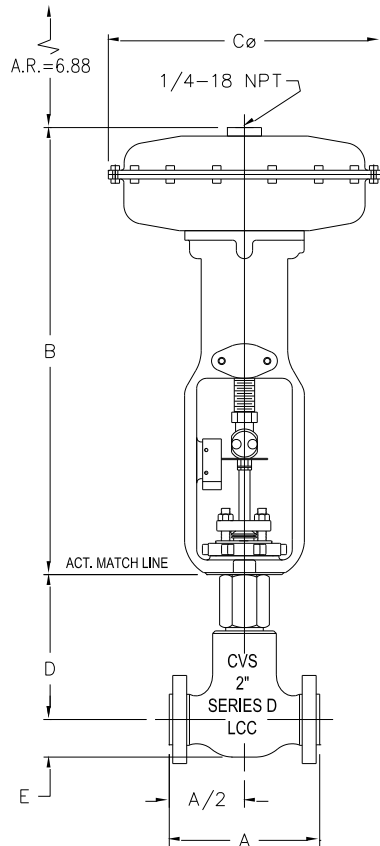
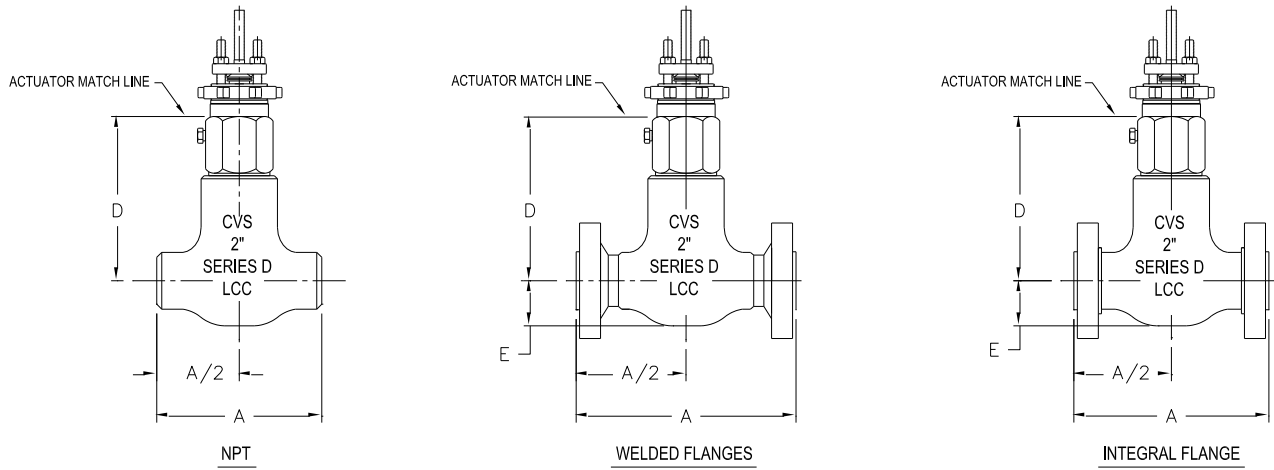

ACTUATOR DIMENSIONS		657		667	
		B	C	B	C
SIZE	30	17.31	11.38	18.81	11.38
	34	19.62	13.13	22.56	13.13
	40	21.56	13.13	23.38	13.13
	45	25.94	16.00	30.25	16.00
	46	25.81	18.63	29.44	18.63
	50	28.44	16.00	30.88	16.00
	60	28.44	18.63	30.88	18.63
70	33.06	21.12	36.75	21.12	

FACE TO FACE VALVE DIMENSIONS							
FLANGED DIMENSIONS "A"	VALVE SIZE	FLANGE STYLE	3600 BODY				6000 BODY
			150 ANSI	300 ANSI	600 ANSI	900/1500 ANSI	2500 ANSI
WELDED FLANGE	1"	RF	9.00	9.75	10.25	11.38	13.25
		RTJ	-	-	10.25	11.38	13.25
INTEGRAL FLANGE	2"	RF	12.00	12.63	13.38	15.00	17.50
		RTJ	-	-	13.50	15.13	17.63
INTEGRAL FLANGE	2"	RF	10.50	10.50	11.25	12.12	15.38
		RTJ	-	-	-	12.25	15.50
SCREWED BODY			"A"	"E"	DIMENSION "D"		
3600 CLASS	1"	NPT	6.63	1.81	6.75	7.50	
	2"		9.00	2.75	-	8.50	
6000 CLASS	1"	NPT	7.25	2.13	6.75	7.50	
	2"		10.50	3.25	-	8.50	

Figure 5: Series D Dimensional Drawings

Note: All dimensions are in inches.

CVS Series DA Dimensions

Face to Center measurements

Flanged Valve Size, Inches	A				D- All Ratings		
	ASME						
	Class 300		Class 600		Stem Size		
	Raised Face	Ring-Type Joint	Raised Face	Ring-Type Joint	9.5 (3/8)	12.7 (1/2)	19.1 (3/4)
Inches							
1	4.31	4.56	4.56	4.56	5.31	6.06	5.56
2	6.12	6.44	6.5	6.56		6.44	6.25

Flanged Valve Size, Inches	A						D- All Ratings			
	ASME				API					
	Class 900 and 1500		Class 2500		10,000 lb.		Stem Size			
	Raised Face	Ring-Type Joint	Raised Face	Ring-Type Joint	Spec A	Spec B	Spec C	9.5 (3/8)	12.7 (1/2)	19.1 (3/4)
Inches										
1	5	5	6.06	6.06				5.31	6.06	5.56
2	7	7.06	7.69	7.75	7.17	7.81	7.09		6.44	6.25

Screwed Valve Size, Inches	3600 psi		6000 psi and 9000 psi		D- All Ratings		
					Stem Size		
	A	G	A	G	9.5 (3/8)	12.7 (1/2)	19.1 (3/4)
Inches							
1 ⁽¹⁾	3	3.5	3.5	4	5.25	6	5.5
2	4	4.88	4.5	5.12		6.38	6.19

1. For 3600 psi and 6000 psi only.

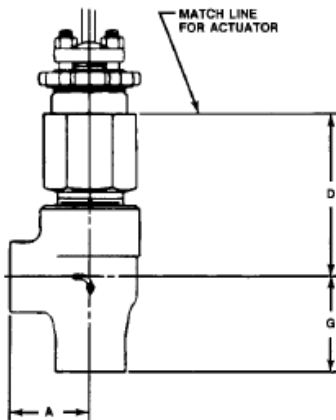

*Approximate Shipping weights – 1” – 34 kg (75 lbs), 2” – 45 kg (100lbs)

PRODUCT BULLETIN – CVS Series D and DA Control Valves

CVS Controls Design D: M-Form Valve Plug

M-Form - Flow Up					Equal Percentage											
Valve Size, NPS	Port Diameter		Total Travel		Flow Coefficient	Valve Opening-Percent of Total Travel										FL(1)
	mm	Inches	mm	Inches		10	20	30	40	50	60	70	80	90	100	
1	6.4	0.25	19	0.75	Cv	0.070	0.115	0.164	0.224	0.315	0.450	0.641	0.921	1.28	1.66	.87
					Kv	0.061	0.099	0.142	0.194	0.272	0.389	0.554	0.797	1.11	1.44	--
					XT	0.783	0.783	0.744	0.691	0.625	0.614	0.608	0.611	0.610	0.611	---
					Fd	0.12	0.14	0.17	0.20	0.24	0.29	0.35	0.43	0.55	0.68	--
	9.5	0.375	19	0.75	Cv	0.155	0.260	0.407	0.596	0.858	1.21	1.65	2.22	3.00	4.03	.84
					Kv	0.134	0.225	0.352	0.516	0.742	1.05	1.43	1.92	2.60	3.49	--
					XT	0.625	0.535	0.534	0.539	0.535	0.535	0.538	0.534	0.537	0.536	--
					Fd	0.11	0.13	0.16	0.19	0.23	0.27	0.33	0.40	0.48	0.56	--
	12.7	0.5	19	0.75	Cv	0.273	0.436	0.631	0.911	1.30	1.84	2.57	3.65	5.08	6.51	.84
					Kv	0.236	0.377	0.546	0.788	1.13	1.59	2.22	3.16	4.39	5.63	--
					XT	0.673	0.644	0.641	0.590	0.592	0.587	0.586	0.557	0.523	0.549	---
					Fd	0.11	0.13	0.16	0.19	0.23	0.27	0.33	0.40	0.48	0.56	--
	19.1	0.75	19	0.75	Cv	0.483	0.775	1.25	1.97	2.89	4.13	5.87	8.16	10.9	12.3	.92
					Kv	0.418	0.670	1.08	1.70	2.50	3.57	5.08	7.06	9.43	10.6	--
					XT	0.571	0.599	0.527	0.473	0.492	0.519	0.537	0.505	0.486	0.628	---
					Fd	0.10	0.39	0.47	0.18	0.22	0.26	0.31	0.37	0.43	0.49	--
2	6.4	0.25	19	0.75	Cv	0.070	0.115	0.164	0.224	0.315	0.450	0.641	0.921	1.28	1.66	.87
					Kv	0.061	0.099	0.142	0.194	0.272	0.389	0.554	0.797	1.11	1.44	--
					XT	0.783	0.783	0.744	0.691	0.625	0.614	0.608	0.611	0.610	0.611	---
					Fd	0.12	0.14	0.17	0.20	0.24	0.29	0.35	0.43	0.55	0.68	--
	9.5	0.375	19	0.75	Cv	0.155	0.260	0.407	0.596	0.858	1.21	1.65	2.22	3.00	4.03	.84
					Kv	0.134	0.225	0.352	0.516	0.742	1.05	1.43	1.92	2.60	3.49	--
					XT	0.625	0.535	0.534	0.539	0.535	0.535	0.538	0.534	0.537	0.536	---
					Fd	0.11	0.13	0.16	0.19	0.22	0.27	0.33	0.41	0.50	0.61	--
	12.7	0.5	19	0.75	Cv	0.348	0.505	0.709	0.998	1.38	1.92	2.69	3.82	5.25	6.82	.81
					Kv	0.301	0.437	0.613	0.863	1.19	1.66	2.33	3.30	4.54	5.90	--
					XT	0.613	0.627	0.585	0.576	0.565	0.553	0.535	0.509	0.490	0.501	---
					Fd	0.11	0.13	0.16	0.19	0.23	0.27	0.33	0.40	0.48	0.56	--
	19.1	0.75	19	0.75	Cv	0.613	0.952	1.44	2.06	2.92	4.13	5.87	8.16	11.1	14.1	.81
					Kv	0.530	0.823	1.25	1.78	2.53	3.57	5.08	7.06	9.60	12.2	--
					XT	0.581	0.616	0.581	0.586	0.581	0.573	0.549	0.541	0.529	0.528	---
					Fd	0.10	0.39	0.47	0.18	0.22	0.26	0.31	0.37	0.43	0.49	--
25.4	1	19	0.75	Cv	1.20	1.68	2.44	3.53	5.05	7.28	10.5	14.0	18.4	23.7	.82	
				Kv	1.04	1.45	2.11	3.05	4.37	6.30	9.08	12.1	15.9	20.5	--	
				XT	0.517	0.569	0.559	0.542	0.544	0.540	0.507	0.508	0.507	0.508	---	
				Fd	0.11	0.12	0.15	0.18	0.21	0.25	0.30	0.35	0.41	0.46	--	
31.8	1.25	19	0.75	Cv	1.32	1.76	2.50	3.66	5.42	8.25	12.7	20.6	29.0	34.5	.85	
				Kv	1.14	1.52	2.16	3.17	4.69	7.14	11.0	17.8	25.1	29.8	--	
				XT	0.521	0.563	0.548	0.534	0.498	0.503	0.553	0.528	0.524	0.579	---	
				Fd	0.087	0.10	0.12	0.15	0.18	0.22	0.28	0.33	0.39	0.44	--	

(1) At 100% Travel

PRODUCT BULLETIN – CVS Series D and DA Control Valves

CVS Controls Design D: M-Flute Valve Plug

M-Flute – Flow Up															Equal Percentage	
Valve Size, NPS	Port Diameter		Total Travel		Flow Coefficient	Valve Opening-Percent of Total Travel										FL(1)
	mm	Inches	mm	Inches		10	20	30	40	50	60	70	80	90	100	
All Sizes 1 and 2	6.4 1 Flute	0.25 1 Flute	19	0.75	Cv	0.0385	0.0455	0.0560	0.0719	0.0942	0.124	0.162	0.212	0.278	0.354	.87
					Kv	0.033	0.039	0.048	0.062	0.081	0.107	0.140	0.183	0.240	0.306	--
					XT	0.778	0.734	0.690	0.653	0.642	0.635	0.637	0.634	0.632	0.656	--
	6.4 3 Flutes	0.25 3 Flutes	19	0.75	Cv	0.0562	0.0725	0.101	0.146	0.216	0.312	0.433	0.588	0.802	1.07	.90
					Kv	0.049	0.063	0.087	0.126	0.187	0.270	0.375	0.509	0.694	0.926	--
					XT	0.692	0.648	0.639	0.625	0.600	0.586	0.597	0.613	0.620	0.624	--

(1.) At 100% Travel

PRODUCT BULLETIN – CVS Series D and DA Control Valves

CVS Controls Design DA: Equal Percentage Valve Plug

Equal Percentage - Flow Down																
Valve Size, NPS	Port Diameter		Total Travel		Flow Coefficient	Valve Opening-Percent of Total Travel										FL(1)
	mm	Inches	mm	Inches		10	20	30	40	50	60	70	80	90	100	
1	6.4	0.25	19	0.75	Cv	0.096	0.173	0.294	0.481	0.727	0.995	1.35	1.99	2.73	3.21	0.45
					Kv	0.0830	0.150	0.254	0.416	0.629	0.861	1.17	1.72	2.36	2.78	--
					XT	0.578	0.379	0.271	0.201	0.154	0.144	0.148	0.129	0.127	0.153	--
	9.5	0.375	19	0.75	Cv	0.189	0.343	0.624	1.05	1.45	1.84	2.47	3.81	5.58	7.06	0.45
					Kv	0.164	0.297	0.540	0.908	1.25	1.59	2.14	3.30	4.83	6.11	--
					XT	0.516	0.355	0.220	0.151	0.152	0.180	0.194	0.163	0.163	0.163	--
	12.7	0.5	19	0.75	Cv	0.487	0.952	1.40	2.07	2.90	3.55	4.54	6.16	8.79	11.2	0.50
					Kv	0.421	0.823	1.21	1.79	2.51	3.07	3.93	5.33	7.60	9.69	--
					XT	0.226	0.137	0.124	0.111	0.111	0.144	0.174	0.185	0.180	0.186	--
	19.1	0.75	19	0.75	Cv	0.840	1.58	2.25	2.86	3.82	5.51	8.69	11.8	14.4	16.8	0.67
					Kv	0.727	1.37	1.95	2.47	3.30	4.77	7.52	10.2	12.5	14.5	--
					XT	0.194	0.142	0.168	0.238	0.288	0.292	0.242	0.259	0.318	0.372	--
2	6.4	0.25	19	0.75	Cv	0.096	0.177	0.353	0.546	0.742	0.995	1.35	1.99	2.73	3.21	0.50
					Kv	0.083	0.153	0.305	0.472	0.642	0.861	1.17	1.72	2.36	2.78	--
					XT	0.578	0.362	0.188	0.156	0.148	0.144	0.148	0.138	0.139	0.164	--
	9.5	0.375	19	0.75	Cv	0.256	0.445	0.734	1.09	1.45	1.84	2.47	3.81	5.58	7.06	0.45
					Kv	0.221	0.385	0.635	0.943	1.25	1.59	2.14	3.30	4.83	6.11	--
					XT	0.394	0.237	0.164	0.140	0.152	0.180	0.194	0.163	0.163	0.163	--
	12.7	0.5	19	0.75	Cv	0.641	1.03	1.55	2.20	2.90	3.55	4.63	7.13	9.86	12.1	0.45
					Kv	0.555	0.891	1.34	1.90	2.51	3.07	4.01	6.17	8.53	10.5	--
					XT	0.265	0.195	0.162	0.143	0.146	0.168	0.179	0.165	0.165	0.164	--
	19.1	0.75	19	0.75	Cv	1.06	1.70	2.25	2.86	3.82	5.51	8.69	13.1	17.4	21.2	0.55
					Kv	0.917	1.47	1.95	2.47	3.30	4.77	7.52	11.3	15.1	18.3	--
					XT	0.209	0.195	0.235	0.295	0.325	0.306	0.245	0.210	0.222	0.235	--
25.4	1	19	0.75	Cv	2.04	2.93	3.59	4.32	5.98	8.71	13.0	19.9	26.7	31.8	0.55	
				Kv	1.76	2.53	3.11	3.74	5.17	7.53	11.2	17.2	23.1	27.5	--	
				XT	0.171	0.176	0.242	0.342	0.343	0.313	0.274	0.227	0.225	0.255	--	
31.8	1.25	19	0.75	Cv	1.72	2.31	3.31	4.71	6.78	10.5	17.6	26.0	35.2	44.9	0.59	
				Kv	1.49	2.00	2.86	4.07	5.86	9.08	15.2	22.5	30.4	38.8	--	
				XT	0.312	0.311	0.311	0.311	0.310	0.310	0.312	0.311	0.311	0.310	--	

(1.) At 100% Travel

PRODUCT BULLETIN – CVS Series D and DA Control Valves

CVS Controls Design DA: Equal Percentage Valve Plug

Equal Percentage - Flow Up																
Valve Size, NPS	Port Diameter		Total Travel		Flow Coefficient	Valve Opening-Percent of Total Travel										FL(1)
	mm	Inches	mm	Inches		10	20	30	40	50	60	70	80	90	100	
1	6.4	0.25	19	0.75	Cv	0.070	0.115	0.164	0.224	0.315	0.450	0.641	0.921	1.28	1.66	0.87
					Kv	0.060	0.100	0.142	0.194	0.273	0.389	0.555	0.797	1.11	1.44	--
					XT	0.783	0.783	0.744	0.695	0.625	0.614	0.609	0.611	0.610	0.611	--
	9.5	0.375	19	0.75	Cv	0.155	0.260	0.407	0.596	0.858	1.21	1.65	2.22	3.00	4.03	0.84
					Kv	0.134	0.225	0.352	0.516	0.742	1.05	1.43	1.92	2.60	3.49	--
					XT	0.625	0.535	0.534	0.539	0.535	0.535	0.538	0.534	0.537	0.536	--
	12.7	0.5	19	0.75	Cv	0.273	0.436	0.631	0.911	1.30	1.84	2.57	3.65	5.08	6.51	0.84
					Kv	0.236	0.377	0.546	0.788	1.12	1.59	2.22	3.16	4.39	5.63	--
					XT	0.673	0.644	0.641	0.590	0.592	0.587	0.586	0.557	0.524	0.549	--
	19.1	0.75	19	0.75	Cv	0.483	0.775	1.25	1.97	2.89	4.13	5.87	8.16	10.9	12.3	0.92
					Kv	0.418	0.670	1.08	1.70	2.50	3.57	5.08	7.06	9.43	10.6	--
					XT	0.571	0.599	0.527	0.473	0.492	0.519	0.537	0.505	0.486	0.628	--
2	6.4	0.25	19	0.75	Cv	0.070	0.115	0.164	0.224	0.315	0.450	0.641	0.921	1.28	1.66	0.87
					Kv	0.061	0.100	0.142	0.194	0.273	0.389	0.555	0.797	1.11	1.44	--
					XT	0.783	0.783	0.744	0.695	0.625	0.614	0.609	0.611	0.610	0.611	--
	9.5	0.375	19	0.75	Cv	0.155	0.260	0.407	0.596	0.858	1.21	1.65	2.22	3.00	4.03	0.84
					Kv	0.134	0.225	0.352	0.516	0.742	1.05	1.43	1.92	2.60	3.49	--
					XT	0.625	0.535	0.534	0.539	0.535	0.535	0.538	0.534	0.537	0.536	--
	12.7	0.5	19	0.75	Cv	0.348	0.505	0.709	0.989	1.38	1.92	2.69	3.82	5.25	6.82	0.81
					Kv	0.301	0.437	0.613	0.856	1.19	1.66	2.33	3.30	4.54	5.90	--
					XT	0.613	0.627	0.585	0.587	0.565	0.553	0.535	0.509	0.490	0.501	--
	19.1	0.75	19	0.75	Cv	0.613	0.952	1.44	2.06	2.92	4.13	5.87	8.16	11.1	14.1	0.81
					Kv	0.530	0.824	1.25	1.78	2.53	3.57	5.08	7.06	9.60	12.2	--
					XT	0.582	0.616	0.581	0.586	0.581	0.573	0.549	0.541	0.529	0.528	--
25.4	1	19	0.75	Cv	1.20	1.68	2.44	3.53	5.05	7.28	10.5	14.0	18.4	23.7	0.81	
				Kv	1.04	1.45	2.11	3.05	4.37	6.30	9.08	12.1	15.9	20.5	--	
				XT	0.516	0.569	0.556	0.542	0.544	0.540	0.507	0.508	0.507	0.508	--	
31.8	1.25	19	0.75	Cv	1.32	1.76	2.50	3.66	5.42	8.25	12.7	20.6	29.0	34.5	0.87	
				Kv	1.14	1.52	2.16	3.17	4.69	7.14	11.0	17.8	25.1	29.8	--	
				XT	0.520	0.563	0.548	0.534	0.498	0.503	0.554	0.528	0.524	0.578	--	

(1.) At 100% Travel

PRODUCT BULLETIN – CVS Series D and DA Control Valves

CVS Controls Design DA: M-Flute Valve Plug

M-Flute - Flow Down															Equal Percentage	
Valve Size, NPS	Port Diameter		Total Travel		Flow Coefficient	Valve Opening-Percent of Total Travel										FL(1)
	mm	Inches	mm	Inches		10	20	30	40	50	60	70	80	90	100	
1 and 2	6.4 1 Flute	0.25 1 Flute	19	0.75	Cv	0.0313	0.0377	0.0470	0.0624	0.0874	0.124	0.175	0.243	0.330	0.407	0.79
					Kv	0.0271	0.0326	0.0407	0.0540	0.0756	0.107	0.151	0.210	0.286	0.352	--
					XT	0.990	0.975	0.867	0.765	0.659	0.569	0.494	0.450	0.450	0.550	--
	6.4 3 Flutes	0.25 3 Flutes	19	0.75	Cv	0.0612	0.0900	0.136	0.210	0.310	0.430	0.573	0.784	1.12	1.42	0.68
					Kv	0.0529	0.0779	0.118	0.182	0.268	0.372	0.496	0.678	0.969	1.23	--
					XT	0.669	0.520	0.388	0.313	0.295	0.306	0.326	0.326	0.313	0.378	--
M-Flute - Flow Up															Equal Percentage	
1 and 2	6.4 1 Flute	0.25 1 Flute	19	0.75	Cv	0.0385	0.0455	0.0560	0.0719	0.0942	0.124	0.162	0.212	0.278	0.354	0.87
					Kv	0.0333	0.0394	0.0484	0.0622	0.0815	0.107	0.140	0.183	0.241	0.306	--
					XT	0.778	0.734	0.690	0.653	0.642	0.635	0.637	0.634	0.632	0.656	--
	6.4 3 Flutes	0.25 3 Flutes	19	0.75	Cv	0.0562	0.0725	0.101	0.146	0.216	0.312	0.433	0.588	0.802	1.07	0.90
					Kv	0.049	0.0627	0.0874	0.126	0.187	0.270	0.375	0.509	0.694	0.926	--
					XT	0.692	0.648	0.639	0.625	0.600	0.586	0.597	0.613	0.620	0.624	--

NOTES:

Head Office
3900 – 101 Street
Edmonton, Alberta, Canada T6E 0A5
Office: (780) 437-3055
Fax: (780) 436-5461



Calgary Sales Office
3516 114 Avenue SE
Calgary, Alberta, Canada T2Z 3V6
Office: (403) 250-1416
Fax: (403) 291-9487

Website: www.cvs-controls.com E-Mail: info@cvs-controls.com
Printed in Canada September 2016

CVS Controls Ltd. strives for the highest levels of quality and accuracy. The information included in this publication is presented for informational purposes only. CVS Controls Ltd. reserves the right to modify or change, and improve design, process, and specifications without written notice. Under no circumstance is the information contained to be interpreted to be a guarantee/warranty with regard to our products or services, applicability or use. Selection, use and maintenance are the sole responsibility of the end user and purchaser. CVS Controls assumes no liability for the selection use and maintenance of any product.