

A heatmeter with a sensor-operated position, flow, delta T, energy control function, including flow, energy, and delta T monitoring, featuring a 2- way PN 16 ball control valve with Flanged

- Nominal supply: DC 24V
- Proportional and communicative control
- Closed cold and hot water systems
- Ethernet TCP/IP, built-in web interface
- Modbus RTU, Modbus TCP/IP, MQTT
- Conversion of sensor signals
- Energy control, delta T, flow control, position control



Type General Information

Type	DN	V'nom [l/min]	V'nom [m³/h]	Kvs Theor. [m³/h]	PN
T-1205-065	065	417	25.0	50	16
T-1205-080	080	667	40.0	80	16
T-1205-100	100	1000	60.0	127	16
T-1205-150	150	2500	150.0	300	16
T-1205-200	200	4167	250.0	500	16
T-1205-250	250	6667	400	800	16
T-1205-300	300	10000	600	1200	16

Kvs theor.: Theoretical Kvs value for pressure drop calculation

Construction

Components: Duyar Smart Valve consists of a ball control valve, a motor, and a heatmeter equipped with a logic and sensor module.

The logic module includes the heatmeter and communication interface. All relevant data is measured and recorded in the sensor module.

- External temperature sensor: 6
- Internal temperature sensor: 5
- Sensor housing: 4
- Logic and sensor module: 3
- Ball control motor: 2
- Ball control valve: 1

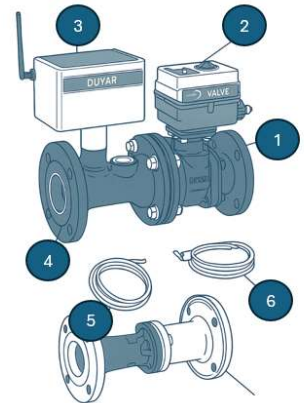

The modular design of the heatmeter allows the logic module to remain in the system even if the sensor module is replaced.

Heatmeter:

It consists of a sensor module with connected temperature sensors, a computing unit, a measurement system, and a logical controller. The built-in LCD screen provides access to energy, flow rate, inlet-outlet temperature values, and temperature difference data. In terms of hardware features, it includes two temperature sensors (one integrated) and operates based on an ultrasonic measurement principle for energy measurement. It functions within a 24 VDC power supply range and can store total energy data in its memory.

Logic Controller:

The Smart Valve performs all logical operations, collects data from connected slave devices, and executes scenario functions using its algorithms.

All communication and valve programming processes are handled in this section. Initial settings can be configured through the integrated interface. The integrated interface can be accessed via Wi-Fi.

Password: 12345678

The address 192.168.4.1 is entered.

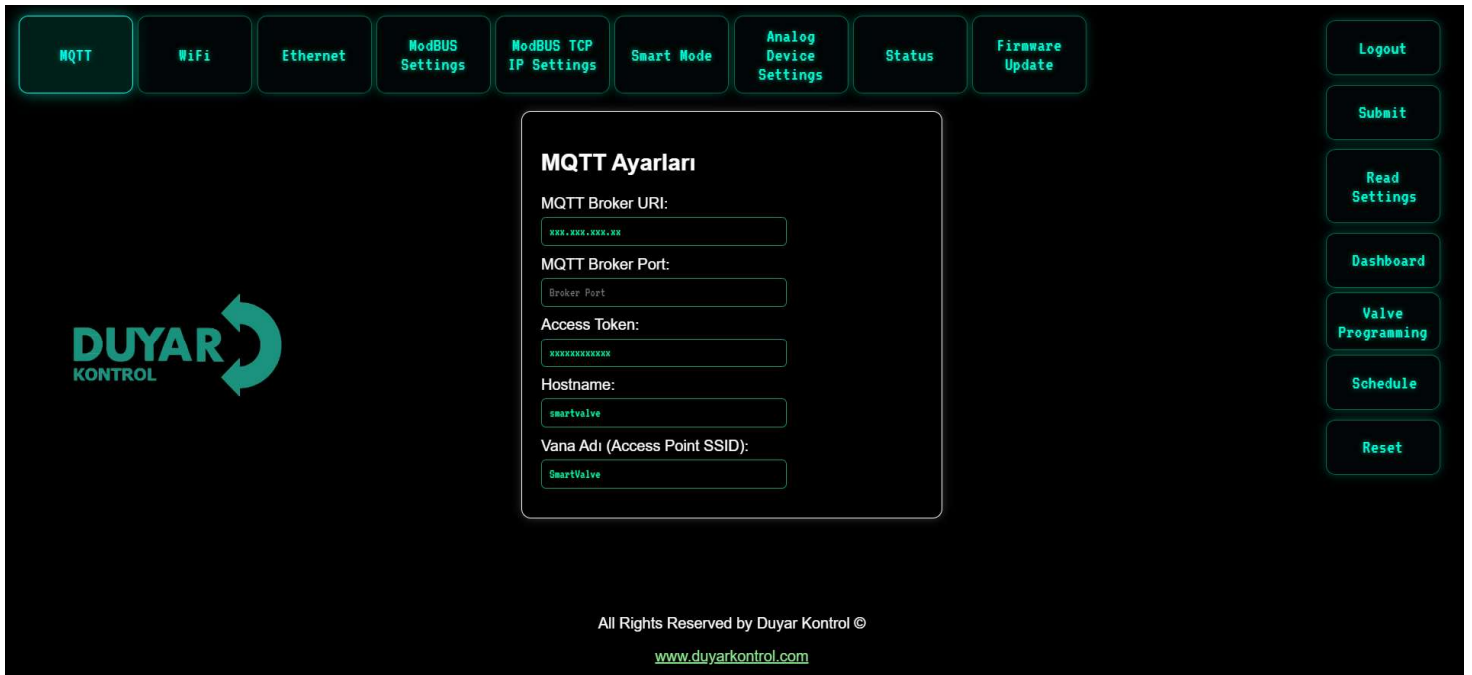

The screenshot displays the DUYAR KONTROL web-based interface. At the top, there is a navigation bar with several menu items: MQTT, WiFi, Ethernet, ModBUS Settings, ModBUS TCP IP Settings, Smart Mode, Analog Device Settings, Status, and Firmware Update. On the right side, there are additional buttons: Logout, Submit, Read Settings, Dashboard, Valve Programming, Schedule, and Reset. The main content area is titled "MQTT Ayarları" (MQTT Settings) and contains the following fields:

- MQTT Broker URI:
- MQTT Broker Port:
- Access Token:
- Hostname:
- Vana Adı (Access Point SSID):

At the bottom of the interface, it states "All Rights Reserved by Duyar Kontrol ©" and provides the website address www.duyarkontrol.com.

- a) **Logic Controller Integrated Interface - MQTT:** This section is where web-based interface settings are configured.
- **MQTT Broker URI:** Must be set to **95.0.1.181**.
 - **Access Token:** Each user has a unique 20-digit access token. This key must be entered in this section; otherwise, access to the web-based interface will not be possible.

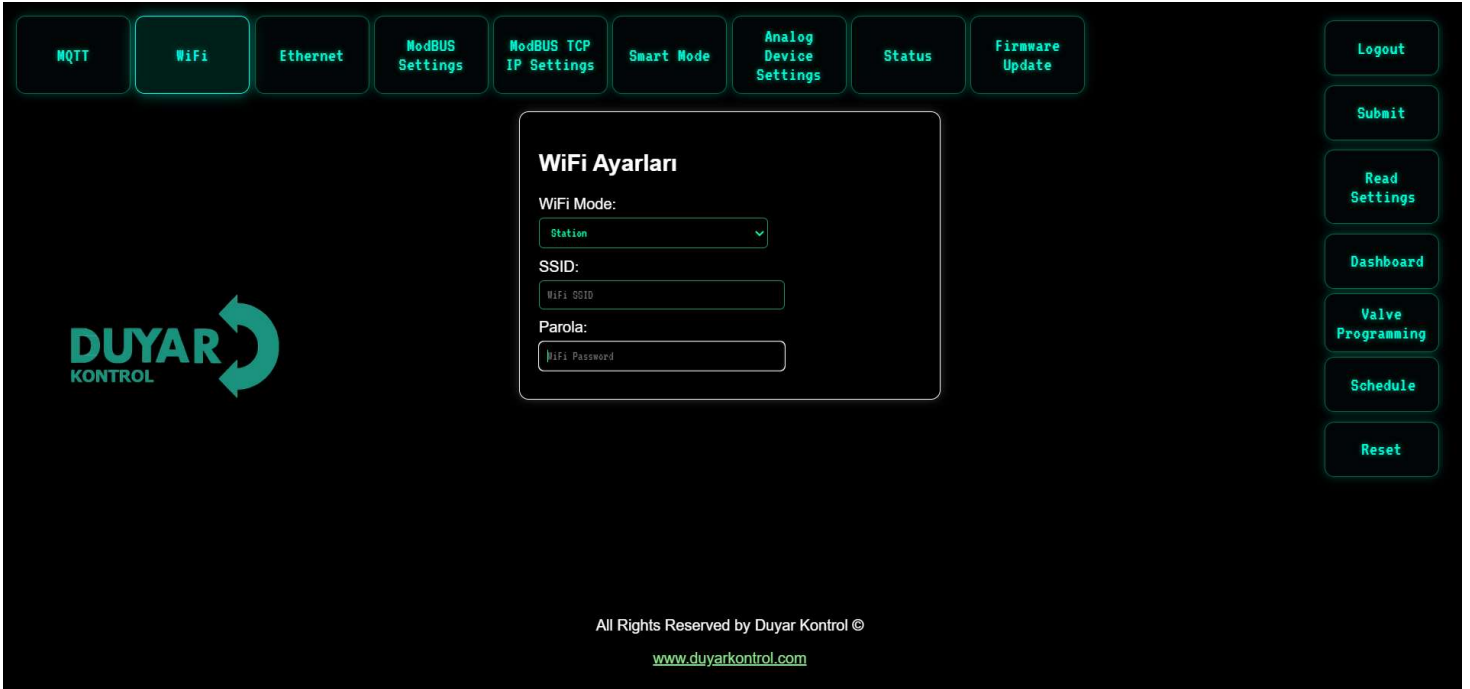

WiFi Ayarları

WiFi Mode:
Station

SSID:
WiFi SSID

Parola:
WiFi Password

All Rights Reserved by Duyar Kontrol ©
www.duyarkontrol.com

b) **Logic Controller Wi-Fi Settings:** This section allows data from the device to be transferred to the web-based interface using a wireless communication option.

- **Wi-Fi Mode:** Station
- **SSID:** Name of the wireless network to connect to
- **Password:** Wireless network password must be entered.

Wi-Fi Mode: By default, it is set to **Access Point** mode. This setting is chosen to enable access to the device.

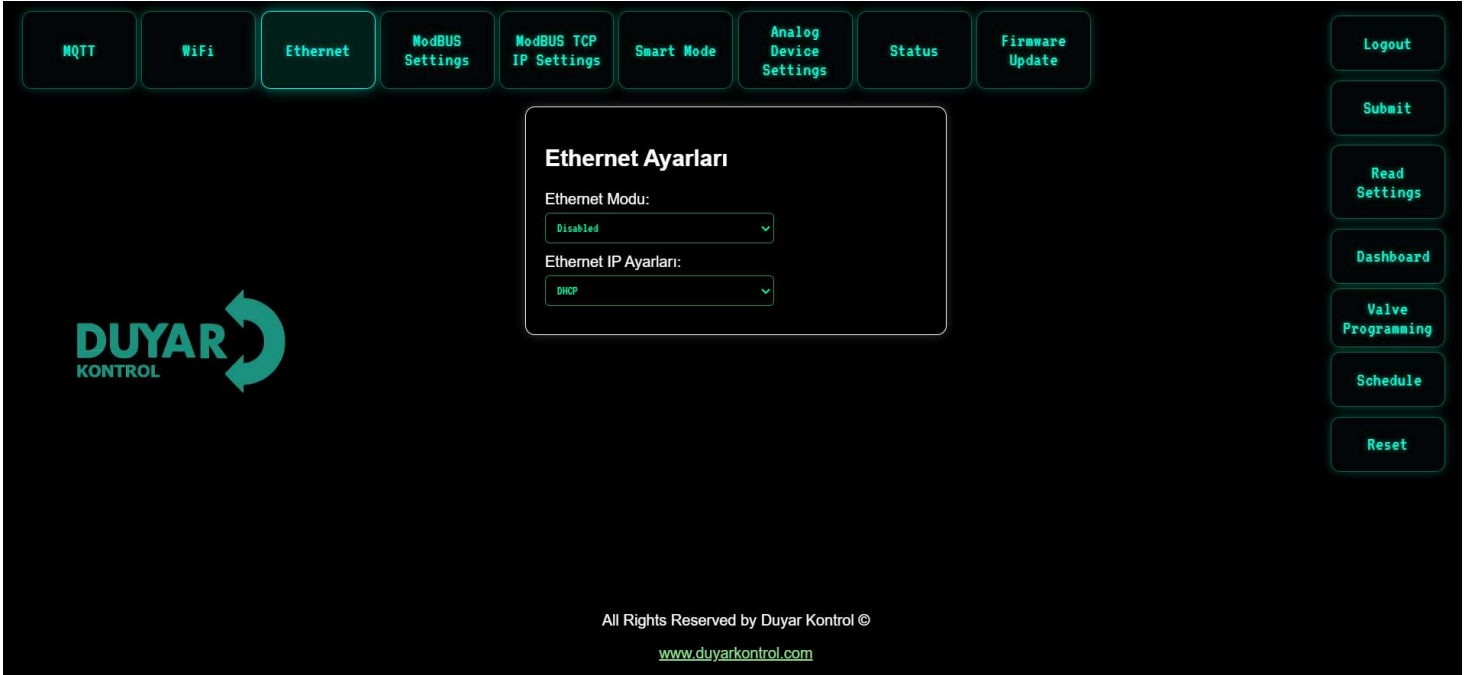

- c) **Logic Controller Ethernet Settings:** If a wired internet connection is to be established via the RJ45 socket:
- **Ethernet Mode:** Should be set to Enabled. IP settings can remain as DHCP.
 - **Wi-Fi Mode:** Should be set to Access Point. Otherwise, the device will attempt to connect to the internet via both wired and wireless connections, which may cause it to enter a reset loop after a while.

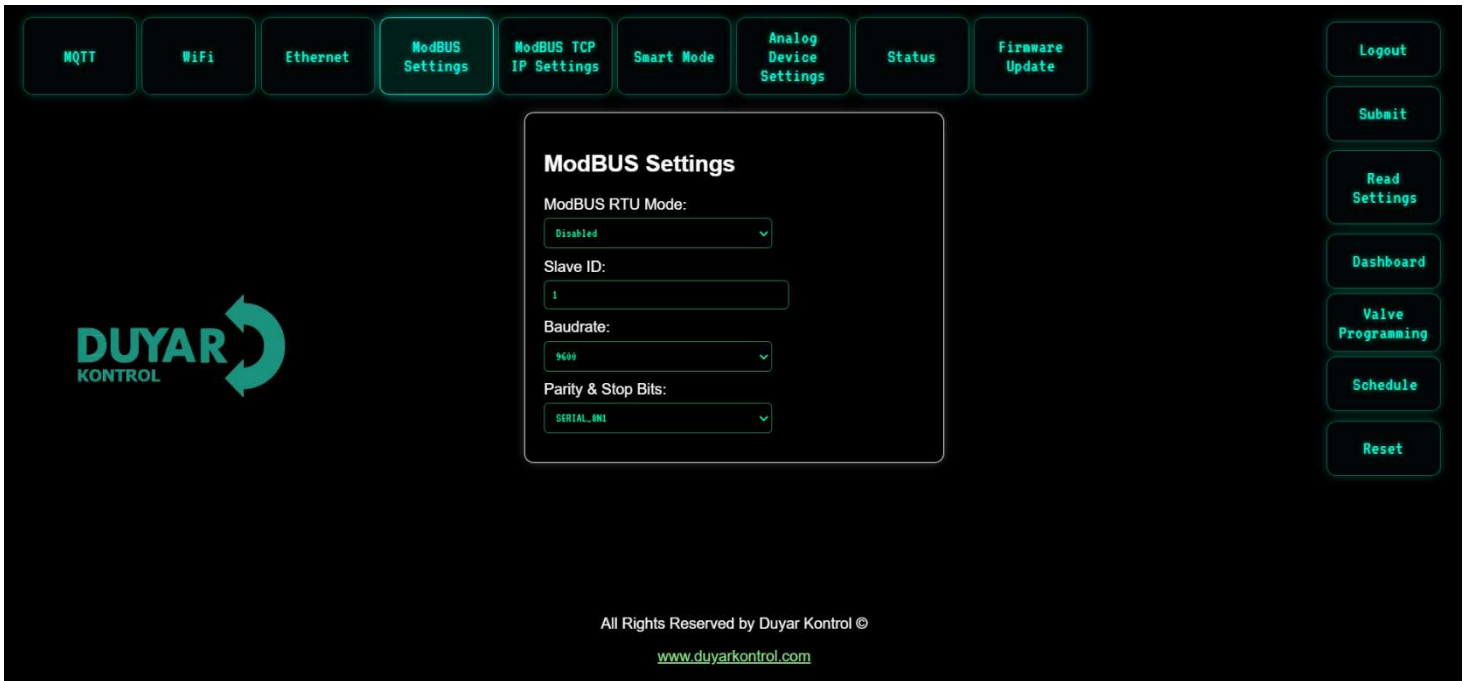

- d) **Logic Controller ModBUS Settings:** If the device is to be controlled via a different SCADA system instead of the web-based interface, the **ModBUS RTU** option can be selected. The user can configure the appropriate communication settings as needed. Baudrate: 2400, 4800, 9600, 19200, 38400, 57600 and 115200

Note: When this option is used, the following settings should be applied:

- Wi-Fi Mode: Access Point
- Ethernet Mode: Disabled
- ModBUS TCP/IP: Disabled
- Smart Mode: OFF

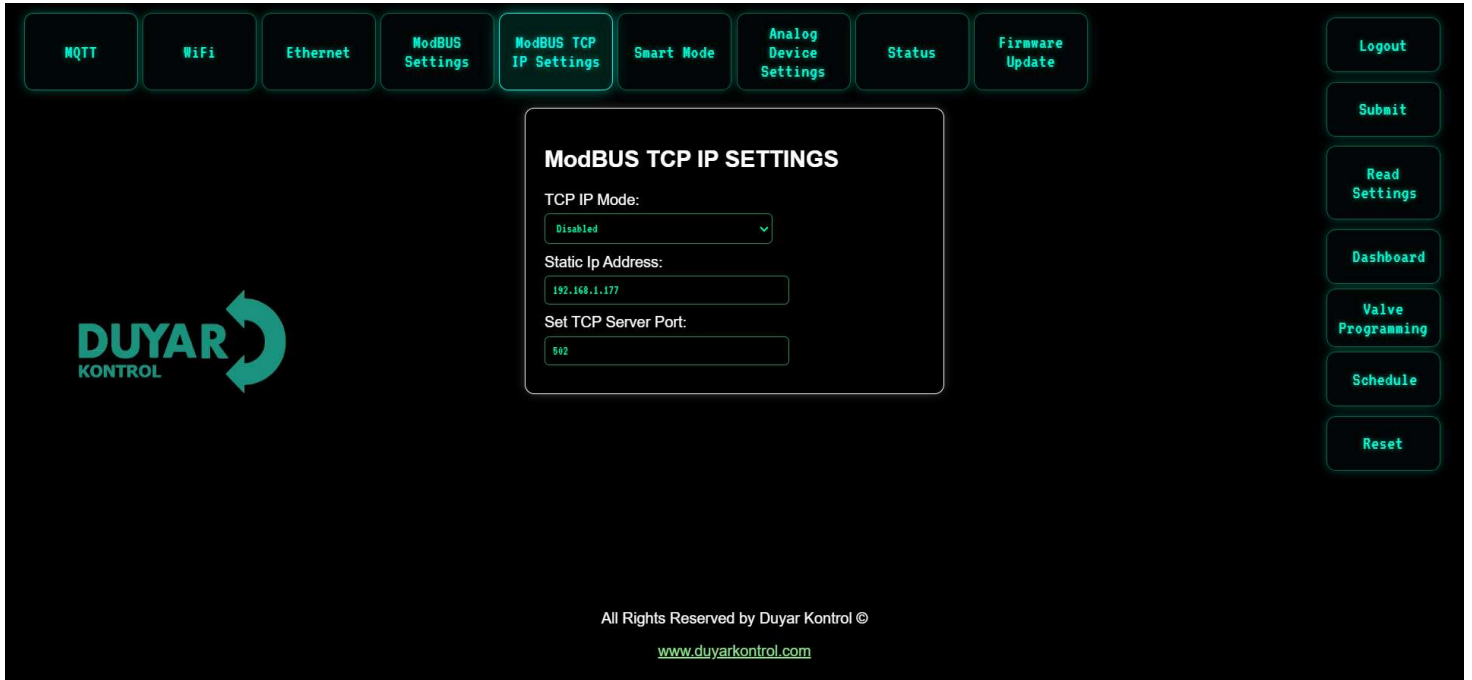

e) **Logic Controller ModBUS TCP/IP Settings:** If the device is to be controlled via a different SCADA system instead of the web-based interface, the ModBUS TCP/IP option can be used.

- **Device Static IP:** 192.168.1.177
- **Server Port:** Default set to 502

Note: When this option is used, the following settings should be applied:

- Wi-Fi Mode: Access Point
- Ethernet Mode: Disabled
- ModBUS RTU Mode: Disabled
- Smart Mode: OFF

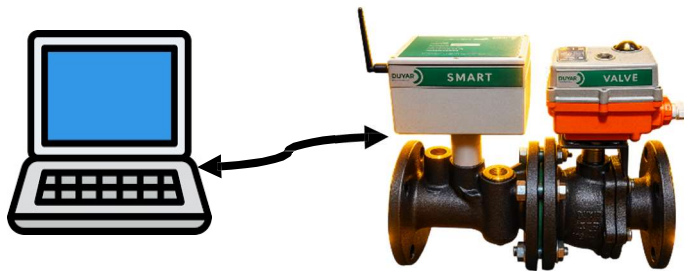

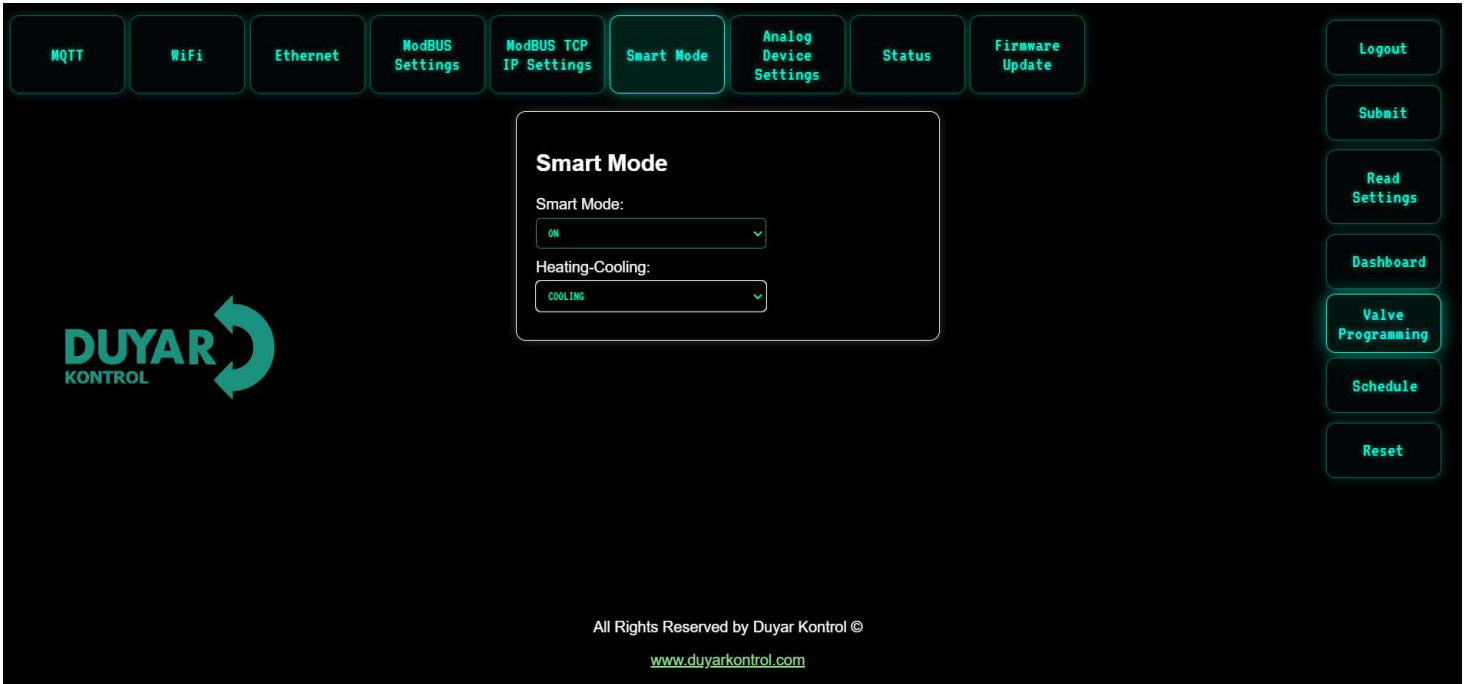

- f) **Logic Controller Smart Mode:** This setting should be set to ON to enable communication with the device through the web-based interface. By activating this mode, you can program the device and access data via the web-based interface. Also, the heating and cooling system can be adjusted as needed.

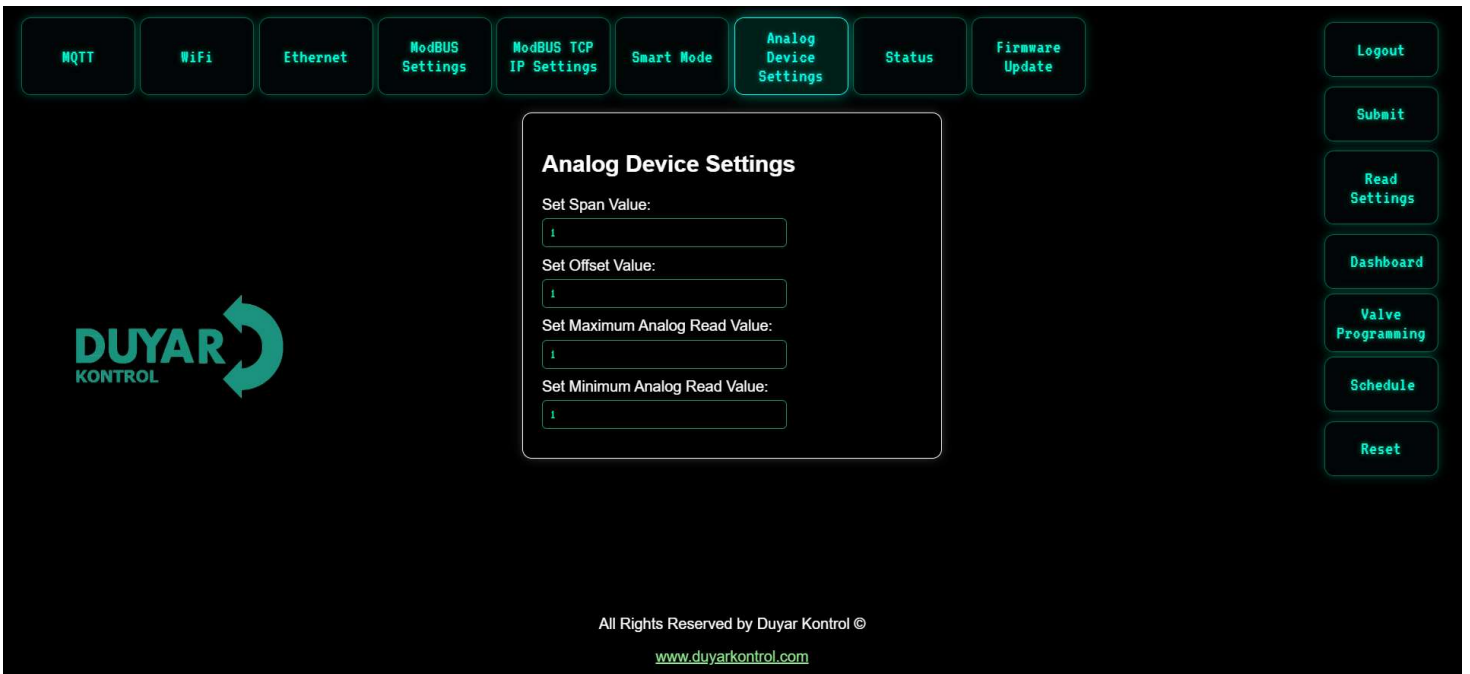

- g) **Logic Controller Analog Device Settings:** This section is used to configure settings when an analog sensor is added to the device. If not used, all parameters should be set to 1.

Device Status

Firmware Version: 1.0.1.1
MQTT Status: CONNECTED
Connected to broker URI: 95.0.1.181
Wi-Fi Status: DEPO
Ethernet Status: NOT CONNECTED
Smart Mode Status: CONNECTED

All Rights Reserved by Duyar Kontrol ©
www.duyarkontrol.com

h) **Logic Controller Status Tab:** This section provides information about the device's connection status.

Firmware Update

Select File:

Dosya seçilmedi

All Rights Reserved by Duyar Kontrol ©
www.duyarkontrol.com

- **i) Logic Controller Firmware Update:** The Smart Valve device can be updated remotely (over-the-air) with firmware updates.
- **j) Logout Button:** Used to exit the interface page.
- **k) Submit:** Sends all configured settings from the interface to the device via this button. After submitting, the Reset button must be pressed.
- **Note:** Before pressing the reset button, ensure that the settings configured in the web-based interface of the Smart Valve device are saved using the Save button. Otherwise, the device will retain the last functionality and data saved.
- **l) Read Settings:** This button retrieves all existing settings from the device.



Valve Data Line (Valve Data Display)

The Valve Data Display provides the user with a detailed view of the system's real-time operating status and measurement values.

- **Valve Live Position:**
Displays the current opening angle/state of the valve in degrees (°), ranging from 0 to 90°.
- **Total Energy Data:**
Shows the total energy consumption measured over the entire system operation, in kWh.
- **Energy Data (Instantaneous Energy):**
Indicates the instantaneous energy consumption value in kW.
- **Flow Data:**
Displays the instantaneous flow rate through the pipeline in m³/h.
- **Total Cubic Data (Total Volume):**
Presents the total volume of fluid that has passed through the system in m³.
- **Hot Temperature Data:**
Shows the temperature of the inlet (hot) line in °C.
- **Cold Temperature Data:**
Shows the temperature of the outlet (cold) line in °C.

- ΔT Temperature Data:**
 Calculates and displays the temperature difference (ΔT) between the inlet and outlet in °C.
- Maintenance Cooldown:**
 Indicates the remaining time until the next maintenance period in seconds.

Valve Situation:

Valve Open: Vana fully open



Valve Control: Valve In Moving

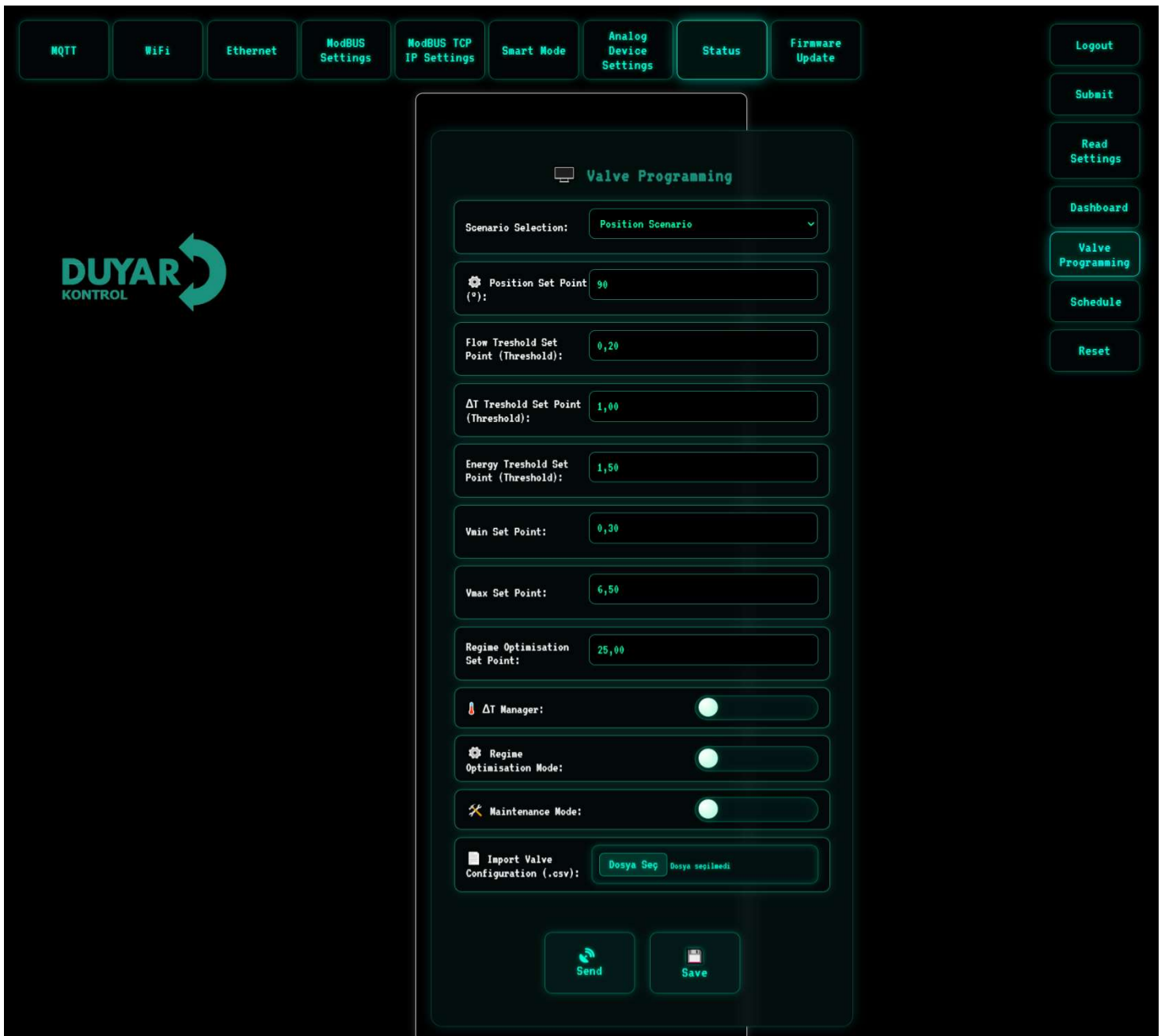

Valve Closed: Valve fully closed

The screenshot displays the 'Valve Programming' configuration page within the DUYAR KONTROL web interface. The page features a top navigation bar with various settings tabs (MQTT, WiFi, Ethernet, ModBUS Settings, ModBUS TCP IP Settings, Smart Mode, Analog Device Settings, Status, Firmware Update) and a right-hand sidebar with navigation buttons (Logout, Submit, Read Settings, Dashboard, Valve Programming, Schedule, Reset). The main configuration area includes the following fields and controls:

- Scenario Selection:** A dropdown menu set to 'Position Scenario'.
- Position Set Point (°):** A text input field containing the value '90'.
- Flow Treshold Set Point (Threshold):** A text input field containing the value '0,20'.
- ΔT Treshold Set Point (Threshold):** A text input field containing the value '1,00'.
- Energy Treshold Set Point (Threshold):** A text input field containing the value '1,50'.
- Vain Set Point:** A text input field containing the value '0,30'.
- Vmax Set Point:** A text input field containing the value '6,50'.
- Regime Optimisation Set Point:** A text input field containing the value '25,00'.
- ΔT Manager:** A toggle switch that is currently turned on.
- Regime Optimisation Mode:** A toggle switch that is currently turned on.
- Maintenance Mode:** A toggle switch that is currently turned on.
- Import Valve Configuration (.csv):** A file upload area showing a file named 'Dosya Seç' with a 'Dosya seçilmedi' (File not selected) message.

At the bottom of the configuration area, there are two buttons: 'Send' and 'Save'.

Valve Programming

This screen allows configuration of the Smart Valve's operating scenarios, threshold values, and control parameters. Users can program the valve behavior in detail according to system requirements.

Settings and Parameters

- **Scenario Selection**

Defines which operating scenario will be used for valve control (e.g., Position Scenario).

- **Position Set Point**

Specifies the target valve opening position as a 0-90°.

- **Flow Threshold Set Point**

Defines the lower and/or upper control limits for flow rate. System responses can be configured when the flow value falls below or exceeds these thresholds.

- **ΔT Threshold Set Point**

Sets the threshold value for the temperature difference (ΔT) between supply and return temperatures.

- **Energy Threshold Set Point**

Defines the threshold value used for control and optimization based on energy consumption.

- **Vmin Set Point (Minimum Flow)**

Specifies the minimum allowable flow rate at which the system can operate.

- **Vmax Set Point (Maximum Flow)**

Specifies the maximum allowable flow rate at which the system can operate.

- **Regime Optimisation Set Point**

A reference value used for regime optimization to improve overall system efficiency.

Control Modes

- **ΔT Manager**

Enables automatic valve control based on the temperature difference (ΔT).

- **Regime Optimisation Mode**

Activates an automatic optimization algorithm to improve energy and flow efficiency.

- **Maintenance Mode**

When Maintenance Mode is enabled, it is automatically activated if the valve remains stationary for an extended period. Within this mode, the valve is periodically moved to a predefined position for a short duration and then returned to its previous position.

Benefits:

- Prevents sticking and seizure risks caused by prolonged inactivity
 - Supports healthy operation of mechanical components
 - Extends valve service life and reduces maintenance requirements
 - Enhances system reliability and continuity
-

Configuration Management

- **Import Valve Configuration (.csv)**

This feature allows previously created valve settings to be imported into the device via a .csv file. Once the settings are loaded, the device operates according to the imported configuration without requiring additional setup.

Control Buttons

- **Send**

Transmits the configured settings to the device.

- **Save**

Stores the settings permanently in memory.

Regime Optimisation

Regime optimisation is a control function designed to ensure that the system reaches the desired operating regime as quickly and efficiently as possible.

Heating Mode

In heating mode, as long as the return water temperature remains below the defined Regime Optimisation Set Point, the valve operates in the fully open position. This allows the system to reach the operating regime rapidly. Once the return water temperature reaches or exceeds the set point, the system is considered to have entered the regime, and valve control is automatically transferred to the previously active scenario (Energy, ΔT , or Energy + ΔT Manager).

Cooling Mode

In cooling mode, as long as the return water temperature remains above the defined Regime Optimisation Set Point, the valve operates in the fully open position. After the system reaches the cooling regime, valve control returns to the active scenario (Energy, ΔT , or Energy + ΔT Manager), and normal operation continues according to that scenario.

a. Position Scenario

In the Position Scenario, the Smart Valve moves to the angle entered via the Smart Valve IoT Interface (Set Position Set Point) and stops once the specified position is reached.

This scenario is used to learn the characteristics of the connected system and to perform adjustments based on the valve opening position.

b. Delta T Scenario ΔT Manager Disabled

1. The Smart Valve reads the temperature differences within the connected system during each control cycle. The valve opening position is adjusted according to the measured temperature difference. Additionally, the system continuously monitors the V_{min} (set minimum flow rate in m^3/h) and V_{max} (set maximum flow rate in m^3/h) limits.

ΔT Manager Enabled

2. The valve movement is directly controlled based on the configured ΔT set value.
 - If the measured ΔT value is below the set ΔT value, the valve moves proportionally toward the closed position.
 - If the measured ΔT value is above the set ΔT value, the valve moves toward the open position.
 - If the measured ΔT value is equal to or within the defined threshold of the set value, the valve maintains its current position.

The system also continuously observes the V_{min} (set minimum flow rate in m^3/h) and V_{max} (set maximum flow rate in m^3/h) constraints.

c. Flow Scenario (EPICV - Electronic Pressure Independent Control Valve)

In this scenario, the system flow rate corresponding to the fully open valve position (90°), which is defined in the Position Scenario, is determined.

This represents the maximum achievable flow rate of the Smart Valve within the piping system. Based on this reference value, the operating adjustment range is defined.

According to the configured flow set point, the valve operates independently of pressure variations.

If the measured flow rate reaches or is equal to the defined threshold of the set flow value, the valve stops and maintains its position. In this mode, the Smart Valve operates as an EPICV (Electronic Pressure Independent Control Valve) and demonstrates EPICV performance characteristics.



Schedule Programming

Start Date: 17.12.2025

Start Time: 09:43

End Date: 17.12.2025

End Time: 09:45

Valve Mode During Schedule: Smart Mode

Valve Mode Outside Schedule: Valve Close

Control Type: Valve

Repeat Mode: Every Day

Schedule Enable:

Send

d. Energy Scenario

In this scenario, energy is calculated using the formula ($\dot{m} \times C \times \Delta T$).

The valve controls the flow rate in order to maintain the configured energy set point.

- If the measured energy value is below the set energy value, the flow rate is increased.
- If the measured energy value is above the set energy value, the flow rate is reduced, provided that the defined Vmin value is not violated. The system continuously monitors the Vmin (set minimum flow rate in m³/h) and Vmax (set maximum flow rate in m³/h) limits.

1. ΔT Manager Disabled

The Smart Valve regulates the flow rate to maintain the configured energy set point.

- If the measured energy value is below the set energy value, the valve increases its opening position to raise the flow rate.
- If the measured energy value is above the set energy value, the valve reduces its opening position to decrease the flow rate.
- If the measured energy value is equal to or within the defined threshold of the energy set point, the valve stops and maintains its current position.

The system continues to observe the Vmin (set minimum flow rate in m³/h) and Vmax (set maximum flow rate in m³/h) constraints.

2. ΔT Manager Enabled

The Smart Valve regulates the flow rate to maintain the configured energy set point.

- If the measured energy value is below the set energy value, the valve increases its opening position to raise the flow rate.
- If the measured energy value is above the set energy value, the valve reduces its opening position to decrease the flow rate.
- If the measured energy value is equal to or within the defined threshold of the energy set point, the valve stops and maintains its current position.

If the measured ΔT value is below or above the configured ΔT set point, the Energy Scenario is temporarily overridden and the system automatically switches to Delta T mode. Once the configured ΔT set value is achieved, control is reassigned to the Energy Scenario. Throughout operation, the system continuously monitors the Vmin (set minimum flow rate in m³/h) and Vmax (set maximum flow rate in m³/h) limits.



Technical Data

Electrical Specifications

Nominal Supply	DC 24 V - Power Supply: 220VAC- 24VDC
Nominal Supply Voltage Frequency	50/60 Hz
Nominal Supply Voltage Range	DC24V
Power Consumption in Operation Mode:	60W (DN 65, 80, 100) 50W (DN150), 80W(DN200)

Connections (Power / Control)	Cable 1 m, 8x 0.75 mm ²
Ethernet Connection	RJ45 soket
Conductors, Cables	AC/DC 24V, cable length <100m, shielding or twisting not required

Data Bus Communication

Communication Control	Modbus TCP, Modbus RTU, MQTT
Position Feedback U	0...10V, 2...10 V
Feedback signal U note	Maks. 1 mA
Adjustable Maximum Flow (V _{max})	25% to 100% of V _{nom}
Control Accuracy	±5% (for 25% to 100% of V _{nom}) Level II

Customization	Via integrated web interface
---------------	------------------------------

Compatible Fluids	Cold and hot water
-------------------	--------------------

Fluid Temperature Range	-10...100°C [14...248°F] Optional (150°C)
-------------------------	---

Fluid Temperature Note	For fluid temperatures between -10°C and 2°C, a shaft heating device or valve neck extension should be used.
------------------------	--

Closing Pressure Δps	16bar
----------------------	-------

	Flow Characteristics	Equal percentage, optimized in the opening range
Functional Data	Sealing Level	Completely leak-proof, Sealing Level: A
	Pipe Connection	Flange
	Mounting Orientation	From vertical to horizontal (based on the shaft)
	Manual Operation Component	Lever(Allen)
Measurement Data	Measured Values	Flow Rate Supply fluid temperature Return fluid temperature Fluid temperature differences Energy
	Temperature Sensor	Pt1000- EN 60751, 2-wire technology permanently attached Cable Length for External Sensor T1: 3 m Integrated Flow Sensor T2
Flow Measurement	Measurement Principle	Ultrasonic Flow Measurement
	Flow Measurement Accuracy:	±%2 (%20...100 V _{nom})
	Minimum Flow Measurement:	0.5% of V _{nom}
	Protection Class (IEC/EN)	IP54, IP67(Optional)
	Pollution Degree	3
Ambient Humidity	Max. %95 relative humidity, non-condensing	
Ambient Temperature	-30...50° C [-22...122° F]	
Storage Temperature	-40...80° C [-40...176° F]	
Materials	Valve Body Material	EN-GJS-400 (GGG 40)

Safety Notes



- This device is designed for use in **fixed heating, ventilation, and air conditioning (HVAC) systems** and should not be used outside the specified application areas, especially in **aircraft or other airborne vehicles**.
- **Outdoor applications** are only permitted if the device is not directly exposed to **water (seawater), snow, ice, sunlight, or corrosive gases**, and if environmental conditions consistently remain within the threshold values specified in the technical catalog.
- Installation must be carried out **only by qualified professionals**. All relevant **regulations must be followed** during installation.
- The device contains **electrical and electronic components** and **must not be disposed of as household waste**. Local disposal regulations must be followed.

Product Features

Operating Mode The HVAC performance device consists of four main components:

- Ball Control Valve (CCV)
- Flow Sensor Measurement Pipe
- Temperature Sensors
- Motor

The HVAC performance device can be controlled via **communication protocols or analog signals**. The fluid is detected by the **sensor inside the measurement pipe**, and the **flow rate** is determined accordingly. The measured value is balanced within the **setpoint range**. The **motor adjusts the valve position** to correct deviations. The **rotation angle (α)** changes based on **differential pressure** via the control element.

Power Calculation The heatmeter calculates instantaneous thermal power based on the **current flow rate and temperature difference**.

Energy Consumption Energy consumption data can be accessed through:

- Bus
- Integrated Web Server
- Web-Based Interface

Spare Parts The thermal energy meter sensor module consist of:

1x Sensor Module with an integrated temperature sensor (T2) and an external temperature sensor(T1).

Power Control Alternatively, the DDC control signal can be assigned to the required output power in the heat exchanger. Based on water temperature and weather conditions, the Smart Valve regulates the required amount of water (V) to achieve the desired power level.

The maximum controllable power in the heat exchanger within the power control module is:

DN 065	1700 kW
DN 080	2400 kW
DN 100	4200 kW
DN 150	9500 kW
DN 200	17300 kW

Control Characteristics The system is calibrated with a precise speed sensor, ensuring stable quality control. However, it is not suitable for fast control processes such as domestic water regulation.

Energy Control

Q_{nom}: The maximum possible output power in the heat exchanger.

Q_{maks}: The maximum power output set by the highest DDC control signal, adjustable between 1% and 100% of Q_{nom}.

Q_{min}: Fixed at 0% (non-adjustable).

Flow Control

V_{nom}: The maximum possible flow rate.

V_{maks}: The maximum flow rate set by the highest DDC control signal, adjustable between 25% and 100% of V_{nom}.

Position Control

In this mode, the control signal is assigned to the valve opening angle (e.g., setpoint = 90, $\alpha = 90^\circ$).

As a result, the operation becomes pressure-dependent, similar to a standard valve.

Motor runtime: 35 seconds for 90° rotation

Creeping Flow Suppression Considering the very low flow rate at the opening point, this is no longer measurable by the sensor within the required tolerance. This range is electronically ignored.

Opening the Valve

The valve remains closed until the flow corresponding to 1% of the required nominal flow (V_{nom}) value is reached by the DDC control signal. Once this value is exceeded, control is activated along the flow characteristic.

Closing the Valve

Control remains active along the flow characteristic until the required flow of 1% of the nominal flow (V_{nom}) value is reached. Once the level drops below this value, the flow is maintained at 1% of V_{nom} . If the level falls below the flow corresponding to 0.5% of V_{nom} as required by the DDC control signal, the valve will close.

Customizable Unit

Factory settings cover most typical applications. Customization can be performed via the internal web server (RJ45 connection via web browser) or through Wi-Fi. Additional information regarding the internal web server can be found in the separate documents provided.

Communication

Customization can be performed via the internal web server (RJ45 connection via web browser) or through Wi-Fi. Additional information regarding the internal web server can be found in the separate documents provided.

"Peer-to-Peer" Connection

<https://192.168.4.1>

The Laptop should be set to "DHCP" Make sure that only one network connection is active.

Standard IP address:

<https://192.168.4.1>

Static IP
address

Password (Read Only):

Username: <duyar>

Password: <1965>

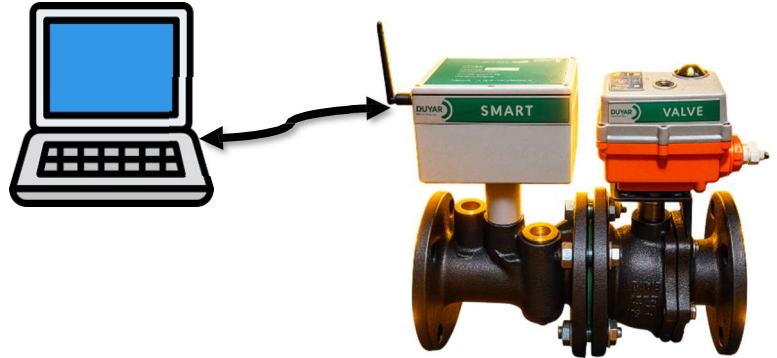

DUYAR
KONTROL

Login

Kullanıcı Adı:

Şifre:

Giriş Yap

Şifre ve Kullanıcı Adı Değiştir

Şifremi Unuttum

Türkçe / English

Tüm haklar Duyar Kontrol'e aittir. ©

www.duyarkontrol.com

DUYAR ACADEMY

Hydronic Balancing

Through the internal web server, the maximum flow rate (equivalent to 100% requirement) can be easily and reliably adjusted in a few steps on the device itself. If the device is integrated into a management system, the balancing can be performed directly by the management system.

Delta-T Manager

If a heating or cooling coil is operated with a very high flow rate and consequently a very low delta T, a high power output will not occur.

Low delta T's cause heat generators or cooling machines to provide energy at lower efficiency. Additionally, too much water is circulated by the pumps, which unnecessarily increases energy consumption.

With the Smart Valve, it is easy to identify off-design operations from the design file and detect inefficient energy use.

The integrated delta T manager allows the user to define a delta T threshold value. If the value falls below this threshold, the Smart Valve automatically limits the flow to prevent this.

The Delta T manager can be activated in energy control and delta T control operating modes. It cannot be used in differential pressure control mode.

Analog - Communication Hybrid Mode

Through an analog DDC control signal, standard control, internal web server, ModbusRTU, ModBUS TCP/IP, and MQTT communication can be used for position feedback.

Power and Energy Monitoring Functions

The HVAC performance device is equipped with two temperature sensors. One sensor (T2) is already mounted on the calorimeter device, and the other sensor (T1) must be mounted in the field on the opposite side of the water circuit. The two sensors are shipped with system connections already made. The sensors are used to record the fluid temperature on the supply and return lines at the consumption point (heating/cooling coil). With the integrated flow measurement in the system, the water amount is known, and the energy consumed by the consumer can be calculated. Additionally, the heating/cooling energy is determined by evaluating the energy over a specific time period.

For example, current data such as temperature, flow volumes, heat exchanger energy consumption, etc., can be recorded and accessed at any time via a web browser or communication unit.

Data Logging

The recorded data can be used for overall system optimization and to determine the performance of the consumption point (heating/cooling coil). CSV files downloaded through the web browser.

Scenario Application: Smart Valve Operation

The smart valve operates according to predefined scenarios.

a. Position Scenario

In this scenario, the smart valve moves to the position defined in the **Set Position Set Point** value entered via the **IoT Interface**. The valve advances to the specified angle and stops when the defined position is reached.

This scenario is used to understand the characteristics of the connected system and to test changes in the valve opening position.

b. Delta T Scenario

DELTA T CONTROLLER OFF

1. The smart valve reads the temperature differences within the connected system during each cycle. The valve opening position is adjusted according to the measured temperature difference values.

The valve operation also respects the following limits:

- **Vmin** - Set minimum flow rate (m³/h)
- **Vmax** - Set maximum flow rate (m³/h)

DELTA T CONTROLLER ON

2. The valve movement is controlled according to the **set Delta T value**.
 - If the measured **Delta T** value is **below the set value**, the valve moves **proportionally toward closing**.
 - If the measured **Delta T** value is **above the set value**, the valve moves **toward opening**.
 - If the measured value is **equal to or within the defined threshold of the set value**, the valve **maintains its current position**.

The system also respects:

- **Vmin** - Set minimum flow rate (m³/h)
- **Vmax** - Set maximum flow rate (m³/h)



c. FLOW SCENARIO (EPICV - Electronic Pressure Independent Control Valve)

In the connected system, the **maximum flow rate** is obtained when the valve is in the **fully open position (90°)** defined in the **Position Scenario**.

This value represents the **maximum achievable flow rate in the piping system** through the smart valve and serves as the reference for defining the adjustment range.

According to the set flow rate value, the valve operates **independently of pressure**.

If the measured flow value reaches the defined **threshold range of the set flow value or equals it**, the valve stops and maintains its position.

This scenario demonstrates the performance of the **EPICV - Electronic Pressure Independent Control Valve**.

d. Energy Scenario

In this scenario, **energy measurement** is calculated using the formula:

$$\text{Energy} = m \times C \times \Delta T$$

The valve controls the **flow rate** to maintain the defined energy set value.

- If the **measured energy is below the set value**, the flow rate is **increased**.
- If the **measured energy is above the set value**, the flow rate is **reduced**, provided that the **Vmin value is not violated**.

The system also respects:

- **Vmin** - Set minimum flow rate (m³/h)
 - **Vmax** - Set maximum flow rate (m³/h)
-

1. When the DELTA T Controller is OFF

The smart valve adjusts the flow rate to maintain the entered **energy set point value**.

- If the measured energy is **below the set energy value**, the valve **increases the opening angle** to increase the flow rate.
- If the measured energy is **above the set energy value**, the valve **reduces the opening angle** to decrease the flow rate.
- If the measured energy is **equal to or within the defined threshold of the set value**, the valve **stops and maintains its position**.

The system also respects:

- **Vmin** - Set minimum flow rate (m³/h)
 - **Vmax** - Set maximum flow rate (m³/h)
-

2. When the DELTA T Controller is ON

The smart valve adjusts the flow rate to maintain the entered **energy set point value**.

- If the measured energy is **below the set energy value**, the valve **increases the opening angle** to increase the flow rate.
- If the measured energy is **above the set energy value**, the valve **reduces the opening angle** to decrease the flow rate.
- If the measured energy is **equal to or within the defined threshold**, the valve **stops and maintains its position**.

However:

- If the measured **Delta T** value deviates from the **set Delta T** value, the system **temporarily overrides the Energy Scenario and automatically switches to Delta T Mode**.
- Once the defined **Delta T** value is achieved, the system **returns to the Energy Scenario**.

The system also respects:

- **Vmin** - Set minimum flow rate (m³/h)
- **Vmax** - Set maximum flow rate (m³/h)



Product Features

- Manual Intervention Element** Control via Allen key (manual opening/closing can be performed with the device on the motor).
- High Functional Safety** The valve motors are protected against mechanical jams. They automatically stop when they reach the end position without the need for limit switches.

Included Parts

Description	Type
RJ connection module IP67 Protected	Panel Type
PT1000 Temperature Sensors	Stainless Steel Waterproof Protection ISO9001 ISO14001 CE

Accessories

Spare Sensor Modules	Description	Type
	Heatmeter Module DN 065	Ultrasonic
	Heatmeter Module DN 080	Ultrasonic
	Heatmeter Module DN 100	Ultrasonic
	Heatmeter Module DN 150	Ultrasonic
	Heatmeter Module DN 200	Ultrasonic
	Tools	Description Type
	For wired and wireless installation, on-site operation, and troubleshooting.	Web Module

Electrical Connections

Power Information:

Red: 24VDC

Black(Blue): 0V

Yellow - Green : Ground

Feedback:

1: RS485 - A + ModBUS RTU

2: RS485 - B - ModBUS RTU

3: OUT 1 - 2 - IN VCC Giriş

4: OUT 1 - Feedback Dry Contact

5: OUT 2 - Feedback Dry Contact

6: Analog Feedback- VCC 24VDC

7: Analog Feedback - OUT SIGNAL

8: Analog Feedback - 0V



The RJ45 socket input enables ModBUS TCP/IP communication or the device's internet connection.

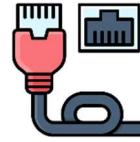



Actuator Information Section

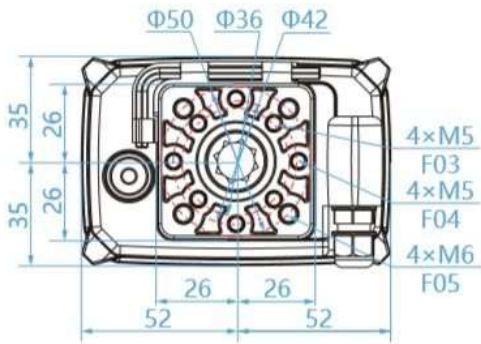
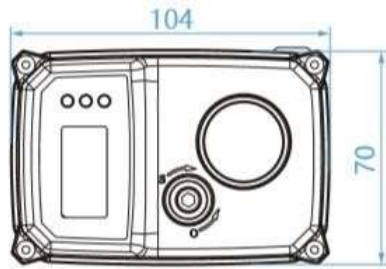
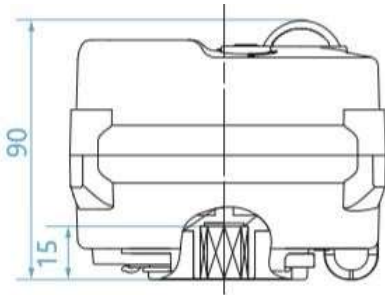
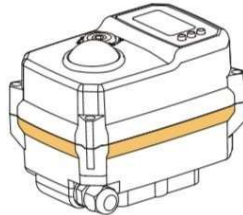
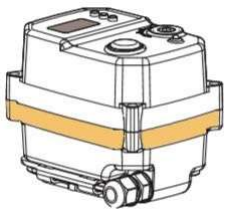

□ 11x11
Hole <11mm

Electrical Connection Information

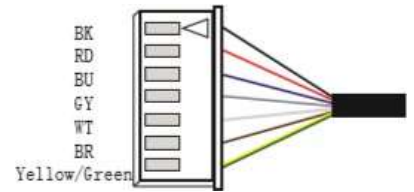
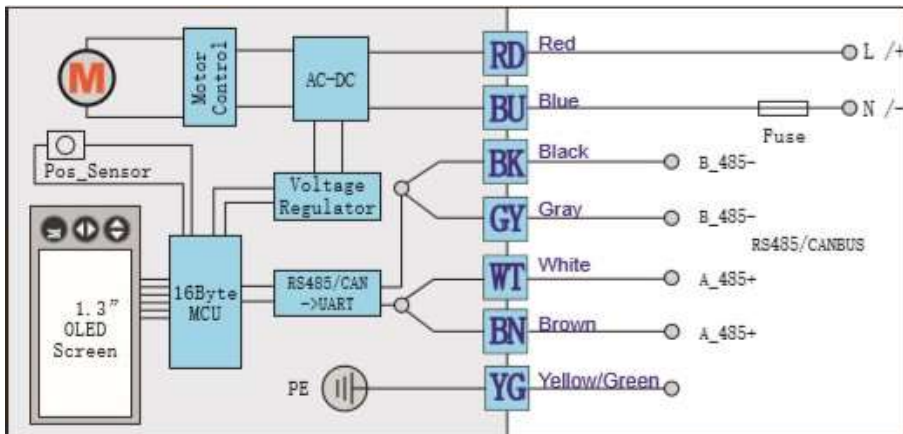

Actuator Information Section

User Parameters

The necessary adjustments can be made through the screen interface on the actuator. These settings are factory-default for the Smart Valve. **It is not recommended to modify these settings.** This section only explains the parameter settings that can be adjusted if the actuator is selected for use.

When the M button on the actuator is pressed for 3 seconds, the user settings screen will appear.

The password for this screen is 312. The password entry is done using the corresponding arrow keys.

Instructions:

- Press K3 to increase the value.
- Press K2 to decrease the value.
- Press M to move to the next item.

M_KEY_ParamSET
Password: 000

M_KEY_ParamSET
Password: 312

NoValvCtr: In this settings screen, when the first power is supplied, if no command is given to the actuator, this setting determines what the actuator should do.

UserSET:
NoValvCtr: ALLDV

UserSET:
NoValvCtr: OFF

UserSET:
NoValvCtr: ON

UserSET:
NoValvCtr: B33

UserSET:
NoValvCtr: KEEP

UserSET:
NoValvCtr: U0DEV

UserSET:
NoValvCtr: U1DEV

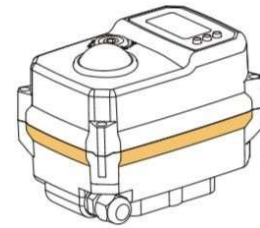

ALLDV: All devices on the serial port

U0DEV: Device serial port 0 - ModBUS data

U1DEV: Device serial port 1 - Bluetooth data transmission

ON: The command is processed to fully open the actuator valve.

OFF: The command is processed to fully close the actuator valve.

KEEP: The actuator will maintain its current position.

B33: The actuator will stop at the position corresponding to the given position range in this command. The position range is from 0% to 100%.

Press the M button to move to the next menu.

UserSET:
DeadZone: X.X%

UserSET:
DeadZone: 0.3%

UserSET:
DeadZone: 9.9%

This is minimum

This is maximum

Deadzone Setting:

The main function is to adjust the valve's control sensitivity.

The larger the deadzone, the less sensitive the valve will be.

The smaller the deadzone, the more sensitive the valve will be, but this tends to cause oscillation in the system.

The system default is 1.0%.

MVF_FilCoe:

The larger the value, the better the filtering effect, but the response time of the actuator to the signal will be longer. Under the condition of ensuring the stability of the input signal, it is recommended that users select a smaller value for this parameter. This value should not be too high. Filtering is disabled when the valve is at the 0 position. The default value is 16.



LPF_Filtcoe: Stands for Low-Pass Filter.

- The smaller the coefficient, the more stable the filtering effect, but the lower the precision.
- The larger the coefficient, the higher the precision, but the filtering effect becomes less stable.
- When the value is 0, filtering is disabled.

Default value: 0.4

- LPF_FiltCoe: 0.4

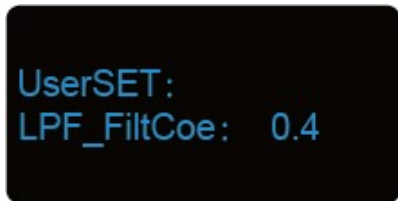

- **Instructions:**
 - Press K3 to increase the value.
 - Press K2 to decrease the value.
 - Press M to proceed to the next item.

Speedmax Settings:



The main function is to set the maximum operating speed.

- When a larger value is selected, the operating speed increases, but the maximum speed will not exceed the nominal speed.
- Note: Adjusting the speed affects the output torque.
- o When a smaller value is selected, the torque also decreases.

System Default: 100%.

SpeedMin Setting:

The main function is to set the minimum operating speed.

- When a smaller value is selected, the operating speed decreases, but the minimum speed will not fall below the nominal speed.
- Note: Adjusting the speed affects the output torque.
- o When a smaller value is selected, the torque also decreases.



Manual Operating Speed Setting:

Instructions:



- Press the K3 button to increase the value by 1%.
- Press the K2 button to decrease the value by 1%.
- Press the M button to proceed to the next setting.

When the user switches to manual operation mode, the operating speed of the actuator is determined by this parameter.

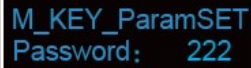

MODBUS Settings:

- Hold the M button, and the "M" icon in the upper right corner will start blinking.
- After approximately 3 seconds, the device will enter "Userset" mode.
- Enter the code "222" on the password screen and proceed to the next setting



ModBus ID Settings:

- InitModbusParam: The initial setting of the ModBus parameters is configured..
- ModBus ID: The default value is set to 100.

Instructions:

- Press the M button to move to the next setting

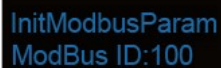

Baud: The user can select different Baud Rate values for the actuator through this parameter.

- **Default Baud Rate:** 9600
- **Selectable Baud Rate:**
 - 1200
 - 2400
 - 4800
 - 9600
 - 19200
 - 38400
 - 57600
 - 115200

```
Init_ModbusRTU  
Baud: 9600
```

Parity: The user can configure this parameter according to the Upper Computer's Parity setting.

- **Options:**
 - Even
 - Odd
 - None
- **Default Setting:** Even

```
Init_ModbusRTU  
Parity: Even
```

```
Init_ModbusRTU  
Parity: Odd
```

```
Init_ModbusRTU  
Parity: None
```

Manual Mode:

Press the K3 button and enter the code 111. After entering, use the arrow keys to turn the device on/off.

```
MANUAL  
Angle: -0.5%
```



Operating Controls and Indicators

- ❶ LCD Panel: Valve Live Position Indicator and Settings
- ❷ Flow Direction
- ❸ Proximity communication interface: Displays Energy, Flow Rate, Inlet-Outlet Temperature, and Difference. Press button number 5
- ❹ Manual intervention element button.

Remove the device: Ensure that the motor is not rotating, remove the device from the motor, and place it in the relevant area. Manual switching on/off is possible



Assembly notes.

Permitted Installation Direction The ball valve can be installed in a position between vertical and horizontal. It cannot be installed in a suspended position, with the shaft facing downward.

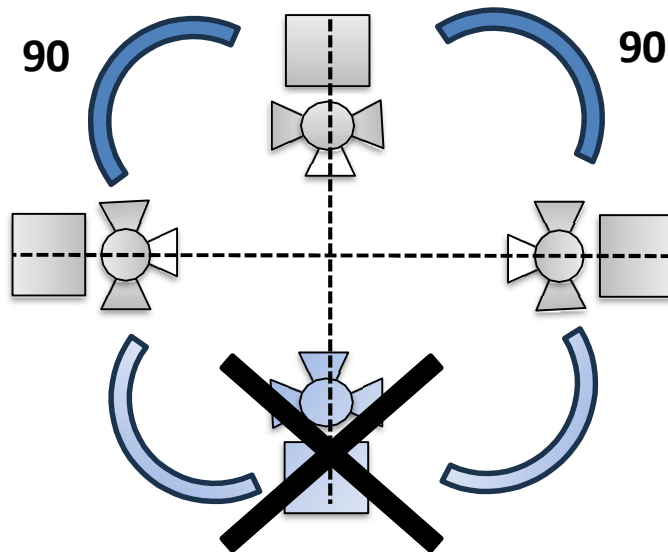

Installation Location, Return Line

It is recommended to install it on the return line

Installation of the Immersion Sleeve and Temperature Sensor:

The valve is equipped with two fully connected temperature sensors.

- T2: This sensor is mounted on the thermal energy measuring instrument.
- T1: This sensor should be installed either before the consumer (on the return line valve; recommended) or after the consumer (on the supply line valve).

Note:

The cables between the valve unit and the temperature sensors should not be shortened or extended.

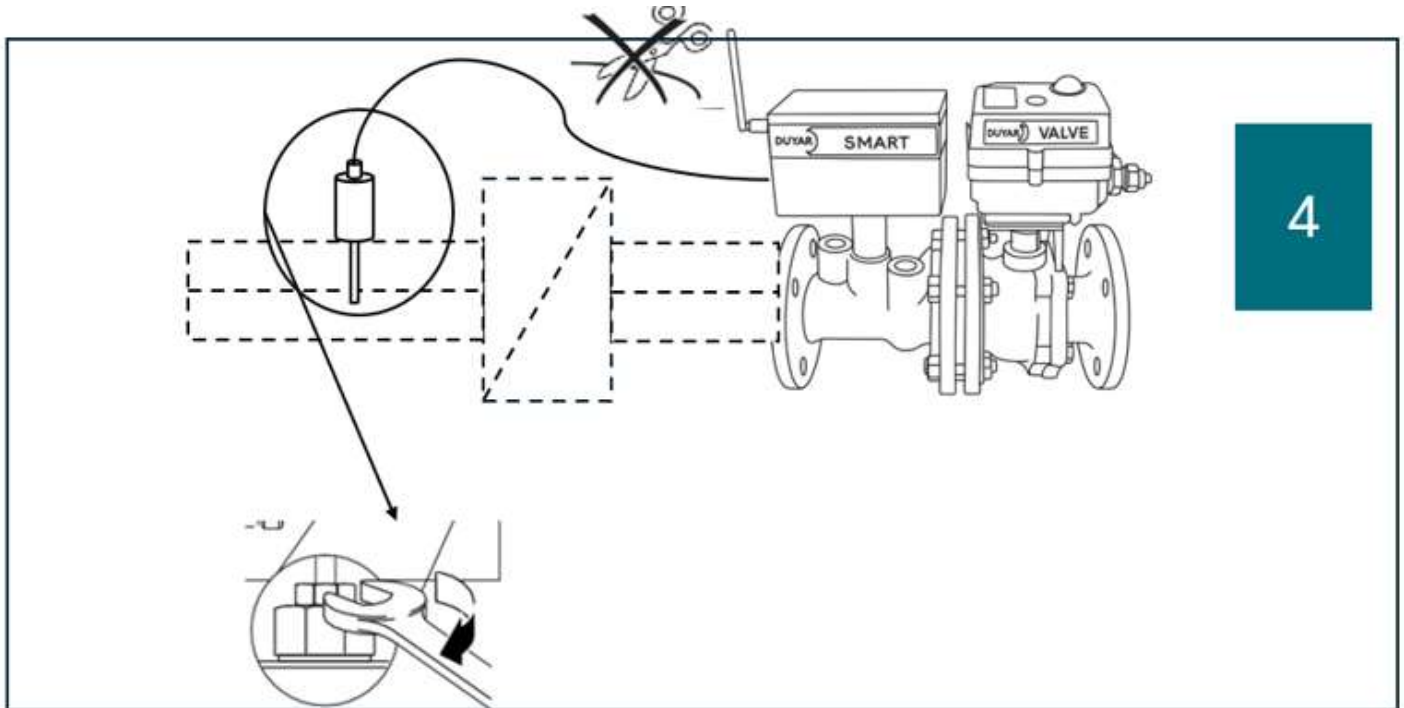

- Water Quality Requirements** The water quality requirements specified in VDI 2035 must be adhered to. Smart valves are adjustment devices. Care must be taken to ensure the valves are not contaminated for proper long-term operation (e.g., welding slag during installation). It is recommended to install an appropriate filter..
- Service** The ball valve, rotary actuators, and sensors do not require maintenance. Before any service work on the control element, it is essential to isolate the rotary actuator from the power source (by disconnecting the electrical cable). Pumps in the relevant section of the pipe system should be stopped, and sliding valves should be closed (if necessary, allow all components to cool, and the system pressure must always be reduced to ambient pressure levels). The globe valve and rotary actuator should not be returned to service until they are correctly installed according to the instructions and the pipework is recharged by trained personnel.
- Flow Direction** The flow direction indicated by an arrow on the housing must be followed; otherwise, the flow will be measured incorrectly.
- Pipe Cleaning** The system should be thoroughly flushed to remove contaminants before installing the heatmeter.
- Stress Prevention** The heatmeter should not be exposed to excessive strain caused by pipes or fittings.
- Inlet Section** To achieve the specified measurement accuracy, a flow stabilization section or an inlet section must be created downstream of the flow sensor in the direction of flow. Its dimensions should be at least 5 x DN

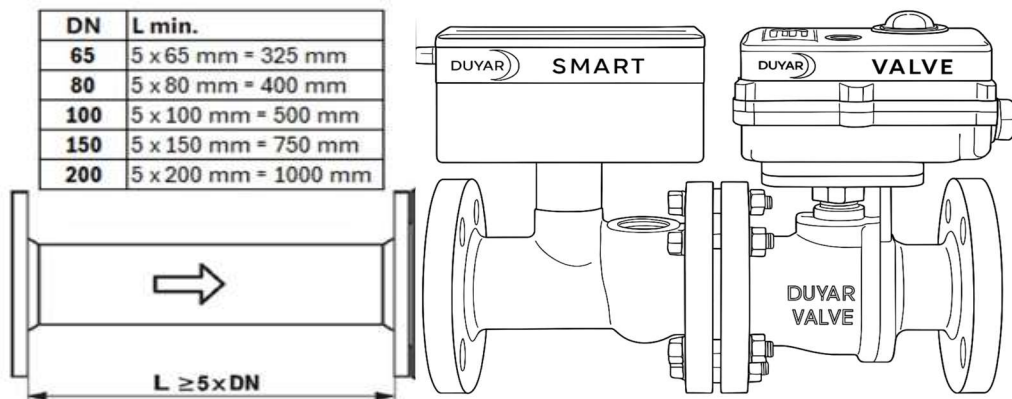

Dimensions - SMART VALVE

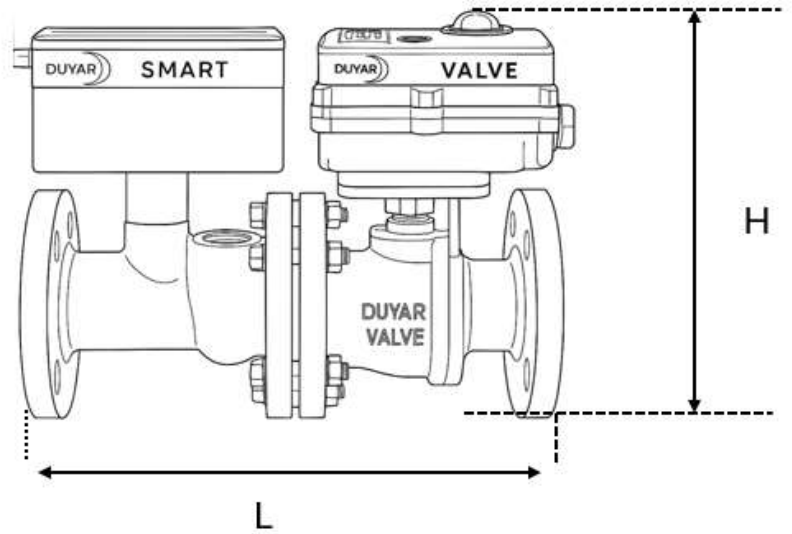
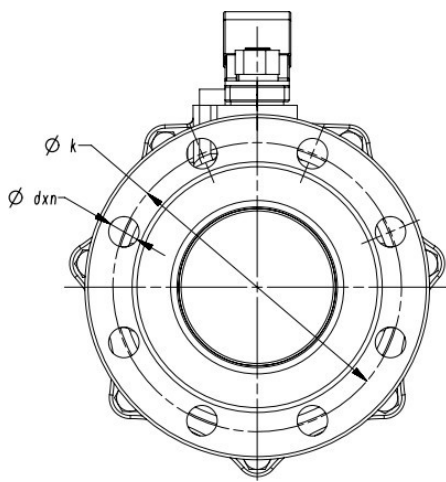

Type	DN	L(mm)	H(mm)	D(mm)	d(mm)	k(mm)
T-1205-065	65	370	330	190	19x4	145
T-1205-080	80	405	360	220	19x8	160
T-1205-100	100	440	450	245	19x8	180
T-1205-150	150	650	570	300	23x8	240
T-1205-200	200	750	700	400	28x12	295

T-1205 AKILLI

