

18m working height telescopic boom with jib on 3.5t+ GVW chassis cab

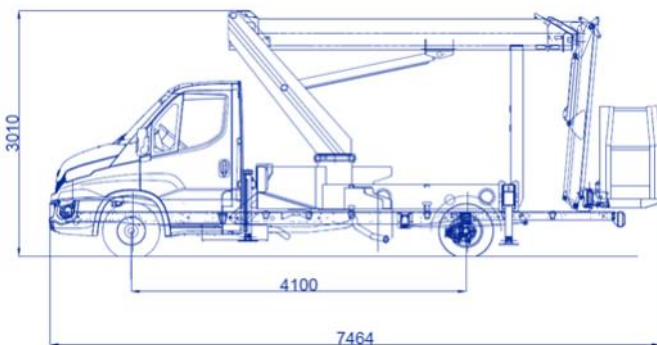

## 18m working height telescopic boom with jib on 3.5t+ GVW chassis cab

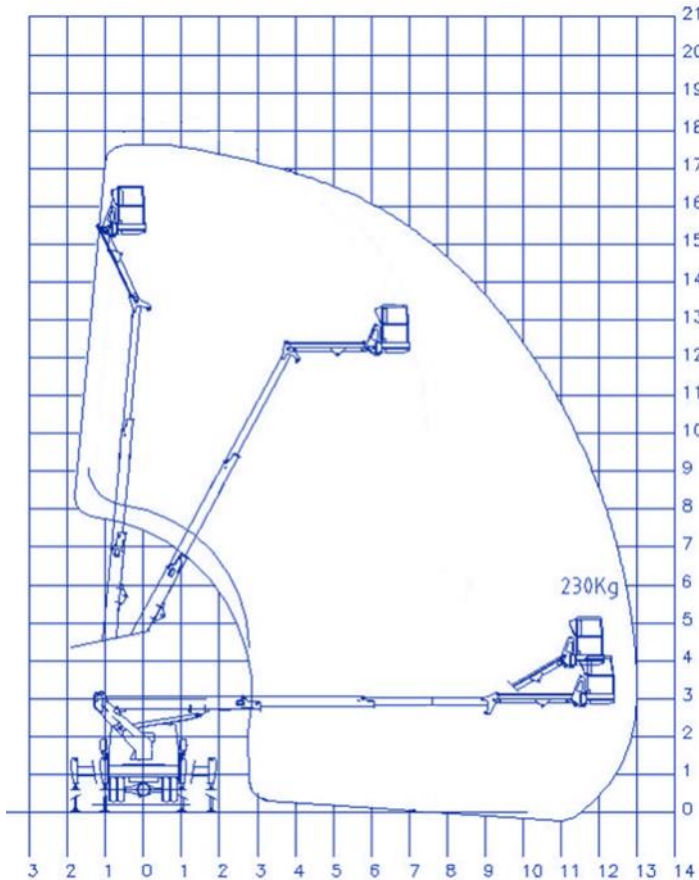

### KEY SPECIFICATIONS

Maximum working height .....	18.0m
Horizontal reach .....	13.0m
SWL in platform (2 person) .....	230kg
Platform size (1.1m high) .....	0.75 x 1.5 m
Turret rotation - full width jacking.....	360 deg.
- one-side jacking.....	180 deg.
Minimum vehicle GVW .....	3500kg
Typical wheelbase .....	3400mm
Stabiliser spread (full).....	3.6m
Spread in 1-side jacking mode.....	2.8m
Power source.....	PTO on vehicle
Kerb weight (no crew) approx. ....	3300kg

### STANDARD FEATURES

- Direct hydraulic proportional controls at cage and base
- 180 degree powered cage rotation
- Four H-section stabilisers with one-sided jacking facility for confined areas
- Two section all steel telescopic boom
- 2.1m long jib with 125 degree working arc
- Structural quality tubular aluminium cage
- Emergency lowering handpump
- Safety interlocks and warning lights for booms, stabilisers and PTO functions

### OPTIONS

- Amber beacons on cab roof
- Work lights at platform
- Hi-viz warning chevrons to vehicle and/or platform
- 110v power cable chassis to cage
- Reverse alarm with night-silent facility
- Polyethylene walk-in enclosed cage

### TYPICAL VEHICLES

- Nissan Cabstar 35.12 LWB Hi-Payload chassis cab
- Iveco 35S12 3450mm wheelbase chassis cab