



CZHGL-150

High Lumen Marine Location LED Flood Light



Catalog Number	
Notes	
Type	

Specifications

Height: 12.72"

Width: 14.2"

Depth: 6.42"

Weight: 17.6 lbs

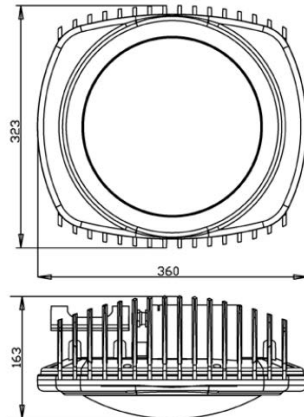

DESCRIPTION

The CZHGL-150 is an efficient, energy saving and long lasting LED flood light. Ideal for new construction or retrofit applications, this LED luminaire can be used in commercial, industrial, and marine environments. The fixture can mount at a broad range of angles with a yoke style arm.

FEATURES

- 18,000 Lumens
- Outperforms 400W metal halide
- Integral 80 to 400VAC power supply
- - 40F ~ 140F
- IP 67 wet location rated
- Stainless steel hardware
- 4' power cord option
- Built in surge and thermal protection
- Operating temperature: -40 to 40 C
- Average LED lifetime: 50,000 hours
- Multiple viewing angle options
- Cree/Osram LED Chips

ORDERING INFORMATION

Series - **Wattage** - **Color Temperature** - **Voltage** - **Beam Angle** - **Options**
 CZHGL* 150A* (150W) 5700K* (cool) UNV* (80 to 400VAC) L60-FL* IP67*
 4000K (neutral) 5Y* (5 Year Warranty)
 4FT* (4'/1.5M cord length)

Example: CZHGL-150A-5700K-UNV-L60-FL-IP67-5Y-4FT

150W LED Flood Light; 5700K color temp; Universal voltage; 60 degree beam angle; IP67; 5 Year Warranty; 4 ft. cord

