

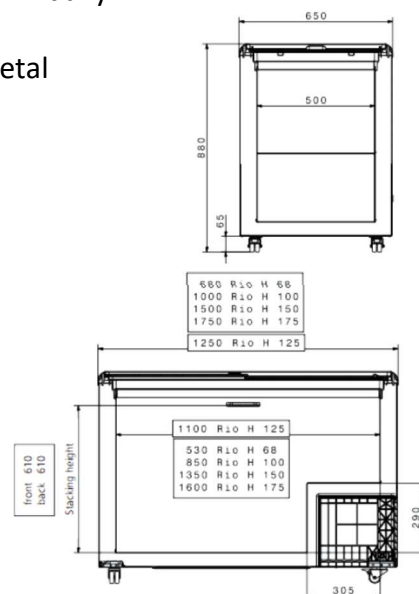

## AHT CHEST FREEZER

- From Europe's AHT Cooling Systems, the global leader in design and production of island freezers
- Energy-efficient intelligent fan motor saves approximately 0.5 kWh daily
- Reinforced insulation (72mm) for low energy consumption
- Inner container made of white, pre-painted, galvanized sheet metal
- Static-cooling outer-skin condenser
- Easy-to-move, 2-part, patented curve or flat glass sliding lids
- Environmentally friendly
- 100% CFC-free and PFC-free
- Adjustable digital thermostat
- Easy to clean and maintain
- Excellent product visibility due to low cabinet height
- Brilliant LED lighting system which enhances product display
- Standard Colors: White Body and Grey Trim
- Optional custom colors available
- One-year Warranty
- Exclusively distributed by Cold Front



Model	Dimensions (mm)	Temperature Range (°C)	Weight (Kgs)	Approximate Volume Capacity (cu ft)
RIO H 68	680*650*880	-14 to -23	53	4
RIO H 125	1250*650*880	-14 to -23	71	9
RIO H 150	1500*650*880	-14 to -23	79	11

Complete with Inner Grid Set, Glass Lid Stopper, Price Tag Label, Top Panel and Side Cover (R404a, 220-230V, 60Hz)



[www.ColdFront.com.ph](http://www.ColdFront.com.ph)



+632 8800 7258



[info@CFTech-Asia.com](mailto:info@CFTech-Asia.com)



ColdFrontTech



ColdFrontTech

**AHT**  
a member of **DAIKIN** group