

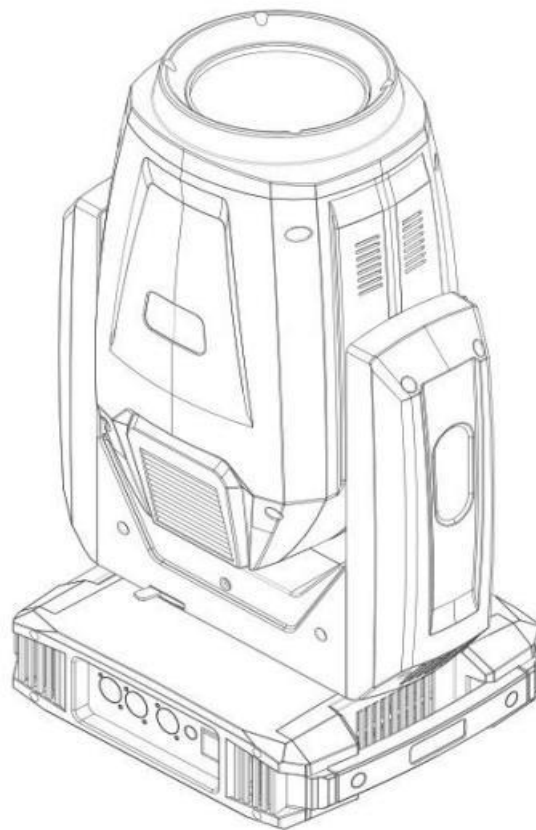

VELA 440BSW

USER MANUAL
20R 440W BSW



CONTENTS

1. Safety Instructions	
2. Technical Specifications	
3. Description	
3.1 Control Panel	
4.2 Light Source	
5. How to Set the Unit	
5.1 Main Function	
5.2 Home Position Adjustment	
5.3 Error Information	
6. Control by Universal DMX Controller	
6.1 Connection	
6.2 Address Setting	
6.3 DMX 512 Configuration	
7. Troubleshooting	
8. Maintenance and Cleaning	

1. Safety Instructions

WARNING

Please keep this User Guide for future consultation. If you sell the unit to another user, be sure that they also receive this instruction manual.

Important:

Damages caused by the disregard of this user manual are not subject to warranty. The dealer will not accept liability for any resulting defects or problems.

Unpack and check carefully that there is no transportation damage before using the unit.

The unit is for indoor use only. Use only in a dry location.

DO install and operate by qualified operator.

DO NOT allow children to operate the fixture.

Use safety chain when fixing the unit. Handle the unit by carrying its base instead of head only.

The unit must be installed in a location with adequate ventilation, at least 50cm from adjacent surfaces.

Be sure, that no ventilation slots are blocked, otherwise the unit will be overheated.

Before operating, ensure that the voltage and frequency of power supply match the power requirements of the unit.

It's important to ground the yellow/green conductor to earth in order to avoid electric shock.

Ambient temperature TA: 0 °C-40 °C.

DO NOT connect the device to any dimmer pack.

During initial start-up some smoke or smell may arise. This is a normal process and does not necessarily mean that the device is defective, and it will decrease gradually within 15 minutes.

Make sure there are no flammable materials close to the unit while operating to avoid fire hazard.

Examine the power wires carefully; replace them immediately if there is any damage.

Unit's surface temperature may reach up to 85°C. DO NOT touch the housing bare-handed during

its operation, and allow about 15 minutes for cooling the unit down before replacing bulb or maintenance as it could be very hot.

Avoid any inflammable liquids, water or metal objects entering the unit. Once it happens, cut off

Please read the instruction carefully which includes important information about the installation, usage and maintenance.

the mains power immediately.

DO NOT operate in dirty or dusty environment, do clean fixtures regularly.

DO NOT touch any wire during operation as there might be a hazard of electric shock.

Avoid power wires together twist other cables.

The minimum distance between light output and the illuminated surface must be more than 18 meters.

Disconnect mains power before fuse/lamp replacement or servicing.

Replace fuse/lamp only with the same type.

In the event of serious operating problem, stop using the unit immediately.

Never turn on and off the unit time after time.

The housing, the lenses, or the ultraviolet filter must be replaced if they are visibly damaged.

DO NOT open the unit as there are no user serviceable parts inside.

Never try to repair the unit by yourself. Repairs carried out by unskilled people can lead to damage or malfunction. Please contact the nearest authorized technical assistance center if needed.

Disconnect the mains power if the fixture is has not been used for a long time.

DO use the original packing materials before transporting it again.

Cautions:

To prevent or reduce the risk of electrical shock or fire, do not expose the unit to rain or moisture.

Hot lamp explosion hazard. DO NOT open the unit within 15 minutes after switching off.

DO replace the bulb once it is damaged, deformed or life-expired.

DO NOT look directly at the light while the bulb is on.

Never touch bulb with bare fingers, as it is very hot after using.

DO NOT start on the unit without bulb enclosure or when housing is damaged.

2. Technical Specifications

Power supply

- AC 100~240V 50/60Hz

Power Consumption

- 600W

Fuse

- T 10A

Light Source

- YODN MSD 440R20

Color Temperature :

- 7800K

Optical system

- High efficiency optical system, delivering extremely powerful output
- High quality dichroic lenses

Movement

- Pan: 540°
- Tilt: 270°
- Pan/Tilt moving speed adjustable.
- Automatic Pan/Tilt correction.
- Easy calibration and maintenance by magnetic home positioning.
- Pan/Tilt position lock for transporting protection.

Dimmer/Shutter

- Blackout, 0~100% smooth dimming, independent shutter and various strobe effect.

Color wheel

- Color wheel: 3 color wheels with 5 color plus white

CMY

- Rainbow effect in both directions.

Gobo wheel

- Gobo Wheel: 1 Fixed gobo wheel with 18 gobos plus open
- 1 Rotating gobo wheel with 7 gobos plus open

Prism

- Prism 1: 16 facet prisms rotating in both directions
- Prism 2: 8prism rotating in both directions

Focus

- Electronic focus effect

Zoom

- Motorized linear zoom system, zoom range: 2°-50°

Protocols

- DMX 512
- Data input/output: 3/5 Pin XLR socket

Weight

- 23Kg

Dimension

- 667x335x393mm

3. Description

3.1 Control Panel

Front view Rear view

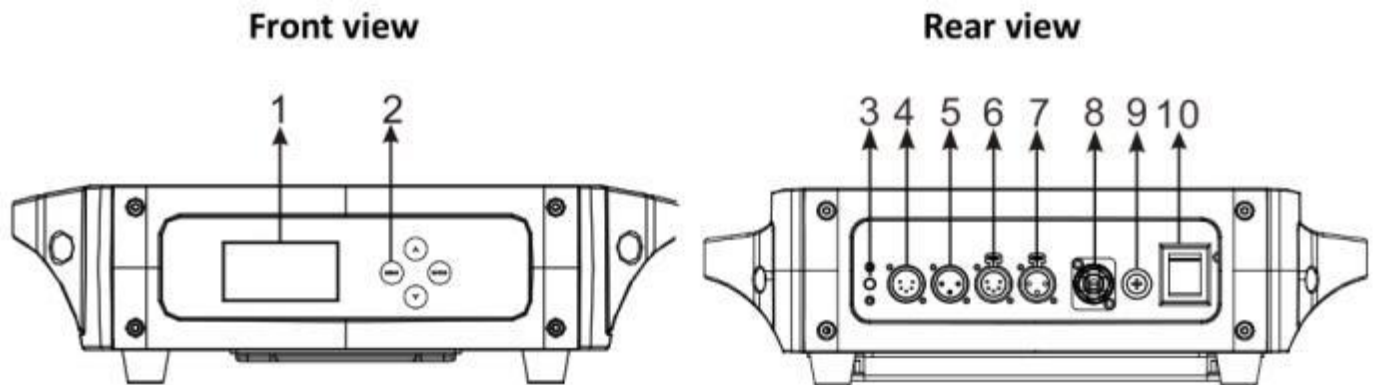

1. Function Display:

Shows the various menus and the selected functions.

2. Button:

The light panel diagram, left area is TFT Displayer, support touch, and right area is encoder button, both of touch and coder button can operate light and setting.

Display & operation just like 'Android operation system, touch the item will set or modify setting.

Note: Prevent damage the touch or TFT displayer, cannot use sharp objects chick displayer.



Operation

Operate light with touch or encoder button

- The left area is TFT Displayer and touch, click item or value with finger will complete operation of set light setting(parameters) or view light state.
- The area on the right-hand side is rotary encoder with button, as auxiliary input interface, if disable touch function, the encoder can be chosen to set or view the item, and then press the encoder button to confirm the selection, rotary encoder again set the parameter value, finally, Press encoder button one again to save value or setting.

Parameter value setting

When the selected item is value need to be modified, the dialog shown in will popup.



- **Modify value:** Can quickly modify value via pull the slider to the desired position, or click the button of 'up' or 'down' with finger on the right side to set the exact desired value, another way is roll encoder on the right-hand side of panel.
- **Apply value:** When Value had been modified, then press the bottom of 'apply' in the left corner to apply to the light, but haven't saved;
- **Save Value:** Any time, click on the lower right corner of the "OK" button, the setting will be saved into internal memory.

Boolean parameter setting

- when the selected parameters is a Boolean value (such as ON or OFF), can directly modify setting by click corresponding item, the setting will be saved right now.
- When the parameter is a key item, click corresponding item, a dialog shown in will be popup ask for the confirm. Click 'sure' to confirm.

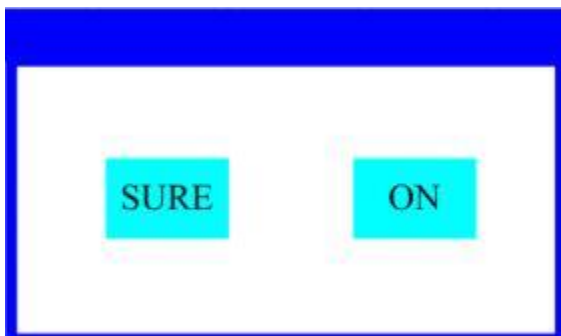

Sub Menu (Parameter)

Click item of main menu, enter corresponding sub menu, total 6 sub menu, includes class of parameter and status:

- ADDRESS: Set light DMX address.
- WORKMOD: Set light work mode, master or slave mode when in auto run mode.
- DISPLAY: Set display parameter, e.g. select language.
- TEST: Used for test light, modify DMX channel data to test function, the corresponding function of reference channel function table.
- ADVANCE: Set light running parameter.
- STATUS: view light current status.



Operation and parameter instruction

Via following operation, enter sub menu (parameter menu)

- In main menu, click 1/6 function button into corresponding parameter menu.
- In sub menu(page), click main item on the left side of display, can shift to corresponding sub menu(page) quickly.

Set DMX Address

Click and select the "ADDR", can enter the page of DMX address setting, range from 1 to 512, the address code shouldn't be not greater than (512- channels quantity), otherwise the light will not been controlled. Following is the operation:

Enter the page of DMX address, click the blank area in right side of display will pop-up dialog as in Fig. 4, modify value, then click 'ENTER' to confirm and save DMX address code.

6.2 Address Setting

If you use a universal DMX controller to control the units, you have to set DMX address from 1 to 512

so that the units can receive DMX signal.

Press the MENU button to enter menu mode, select DMX Functions, press the ENTER button to confirm, use the UP/DOWN button to select DMX Address, press the ENTER button to confirm, the present address will be blinking the display, use the UP/DOWN button to adjust the address from 001 to 512, press the ENTER button to store. Press the MENU button back to the last menu or idling let the unit idle one minute to exit menu mode.

Please refer to the following diagram to address your DMX512 channel for the first 4 units.

Channel mode	Unit 1 Address	Unit 2 Address	Unit 3 Address	Unit 4 Address
26	1	27	53	79

6.3 DMX 512 Configuration

Please refer to below configurations to control the fixtures

Attentions:

1. The unit will maintain the last condition until reset if you cut-off the DMX signal.
2. For the channel Function, keep the value for about 5 seconds, then the corresponding function will take into effect.

26Channels (Mode 1):

CHANNEL1	Designation	Value	FUNCTION
CH1	PAN	0-255	Pan : 0° - 540°
CH2	PAN FINE	0-255	Pan Fine : Fine Pan positioning
CH3	TILT	0-255	Tilt 0°– 244°
CH4	TILT FINE	0-255	Tilt Fine : Fine Tilt positioning
CH5	PAN/TILT STEED	0-255	Pan/Tilt Speed shaking fast to slow
CH6	FUNCTION	100-105	Lamp OFF
		110-115	Lamp ON
		210-215	Reset XY
		220-235	Reset Effect
		240-255	Reset All
CH7	Cyan	000-255	Linear adjustment from light to dark for Cyan
CH8	Magenta	000-255	Linear adjustment from light to dark for Magenta

CH9	Yellow	000-255	Linear adjustment from light to dark for Yellow
CH10	COLOR1	000-127	Linear colour
		128-148	Open
		149-169	Colour 1
		170-191	Colour 2
		192-212	Colour 3
		213-233	Colour 4
		234-255	Colour 5
CH11	COLOR2	000-127	Linear colour
		128-148	Open
		149-169	Colour 1
		170-191	Colour 2
		192-212	Colour 3
		213-233	Colour 4
		234-255	Colour 5
CH12	COLOR3	000-127	Linear colour
		128-148	Open
		149-169	Colour 1
		170-191	Colour 2
		192-212	Colour 3
		213-233	Colour 4
		234-255	Colour 5
CH13	GOBO1	000-003	Open
		004-009	GOBO 1
		010-015	GOBO 2

CHANNEL1	Designation	Value	FUNCTION
CH13	Static GOBO	16-21	Gobo3
		22-27	Gobo4
		28-33	Gobo5
		34-39	Gobo6
		40-45	Gobo7
		46-51	Gobo8
		52-57	Gobo9
		58-63	Gobo10
		64-69	Gobo11
		70-75	Gobo12
		76-81	Gobo13
		82-87	Gobo14
		88-95	Gobo1 shaking slow to fast
		96-103	Gobo2 shaking slow to fast
		104-111	Gobo3 shaking slow to fast
		112-119	Gobo4 shaking slow to fast
		120-127	Gobo5 shaking slow to fast
		128-135	Gobo6 shaking slow to fast
		136-143	Gobo7 shaking slow to fast

		144-151	Gobo8 shaking slow to fast
		152-159	Gobo9 shaking slow to fast
		160-167	Gobo10 shaking slow to fast
		168-175	Gobo11 shaking slow to fast
		176-783	Gobo12 shaking slow to fast
		184-199	Gobo13 shaking slow to fast
		200-201	Empty position
		202-227	Continuous gobo wheel clockwise rotation at linearly variable speed from fast to slow
		228-229	Stop rotation
		230-255	Continuous gobo wheel counter-clockwise rotation at linearly variable speed from slow to fast
CH14	Animation WHEEL	00-005	Empty position
		006-055	SPOT WHITE
		056-105	shaking slow to fast 1
		106-155	shaking slow to fast 2
		156-205	shaking slow to fast 3
		206-255	Continuous animation disk counter-clockwise rotation at linearly variable speed from slow to fast
CH15	Rotating GOBO	0-010	Empty position
		011-020	GOBO1
		021-030	GOBO2
		031-040	GOBO3
		041-050	GOBO4
		051-060	GOBO5

CHANNEL1	Designation	Value	FUNCTION
CH15		61-70	Gobo6
		71-80	Gobo7
		81-90	Gobo1 shaking slow to fast
		91-100	Gobo2 shaking slow to fast
		101-110	Gobo3 shaking slow to fast
		111-120	Gobo4 shaking slow to fast
		121-130	Gobo5 shaking slow to fast
		131-140	Gobo6 shaking slow to fast
		141-150	Gobo7 shaking slow to fast
		151-199	Continuous gobo wheel clockwise rotation at linearly variable speed from fast to slow
		200-202	Stop rotation
		203-255	Continuous gobo wheel

			counter-clockwise rotation at linearly variable speed from slow to fast
CH16	GOBO Rotation	0-127	Gobo indexing:0°to 400°range
		128-190	Continuous gobo wheel clockwise rotation at Linearly variable speed from fast
		191-192	Stop rotation
		193-255	Continuous gobo wheel counter-clockwise rotation at linearly variable speed from slow
CH17	PRISM1	0-127	Prism out
		128-191	Prism 1 into the light beam
		192-255	Prism 2 into the light beam
CH18	Prisms 1 Rotation	0-127	Prism indexing:0°to 400°range
		128-190	Continuous gobo wheel clockwise rotation at Linearly variable speed from fast
		191-192	Stop rotation
		193-255	Continuous gobo wheel counter-clockwise rotation at linearly variable speed from slow
CH19	Prism amplification.	000-255	linearly moves from narrow to wide be
CH20	Rainbow	000-127	Empty position
		128-255	Rainbow
CH21	Frost	000-127	Empty position
		125-255	Frost moves linearly into the light beam
CH22	Zoom	000-255	Zoom linearly moves from narrow to wide beam
CH23	Focus	000-255	Focus moves linearly into the light beam
CH24	Focus Fine	000-255	Fine Focus positioning
CH25	Strobe	000-003	Light OFF
		004-103	Strobe at linearly variable frequency From low to high
		104-107	Light ON
		108-207	Pulsation at linearly variable speed from slow to fast
		208-212	Light ON
		213-251	Random Strobe at low frequency
		252-255	Light ON
CH26	Dimmer	000-255	0-100%

7. Troubleshooting

Following are a few common problems that may occur during operation. Here are some suggestions

for easy troubleshooting:

A. The unit does not work, no light and the fan does not work

1. Check the connect power and main fuse.
2. Measure the mains voltage on the main connector.
3. Check the power on LED to see if it can be light up or not.

B. Not responding to DMX controller

1. DMX LED should be on. If not, check DMX connectors, cables to see if they are linked properly.
2. If the DMX LED is on and no response to the channel, check the address settings and DMX polarity.
3. If you have intermittent DMX signal problems, check the pins on connectors or on PCB of the unit or the previous one.
4. Try to use another DMX controller.
5. Check to see if the DMX cables run near or run alongside to high voltage cables that may cause damage or interference to DMX interface circuit.

C. One of the channels is not working well

1. The stepper motor might be damaged or the cable connected to the PCB is broken.
2. The motor's drive IC on the PCB might be out of condition.

D. The lamp is cutting out intermittently

1. The lamp is not working well. Check the mains voltage either too high or too low.
2. Internal temperature may be too high. Check if replacement of fan is needed on the head.

E. If The pan belt is broken

1. Turn off the mains power.
2. Loosen the screws (A) , open the cover(B).
3. Loosen the motor gear (C).
4. Loosen the screws (D)
5. Unplug all the connect wires over the belt.
6. Change a new belt (E), put the belt around the axis gear and motor gear.
7. Plug all the connect wires back upon the belt.
8. Tighten all the screws.

F. If The tilt belt is broken

1. Turn off the mains power.
2. Loosen all the screws (A) and open the right arm cover (B).
3. Loosen the screws (C) that fix the bridge.
4. Change a new belt (D). Please adjust the tension of the belt properly. Note: do not fix the belt too tight as it is can easily rupture.
5. Reverse the procedures from step 3 to 2.

8. Maintenance and Cleaning

Maintenance:

- A. As the pictures shown above, please replace the cable or cable joints immediately once they've turned yellow.
- B. Do maintain the fixtures every two months and make sure that all the screws and terminals have been locked firmly to make sure the normal performance of the fixtures. Negligence of maintenance would cause malfunction of the fixture.

Cleaning:

The cleaning of internal and external optical lenses and/or mirrors must be carried out periodically to optimize light output. Cleaning frequency depends on the environment in which the fixture operates: damp, smoky or particularly dirty surrounding can cause greater accumulation of dirt on the unit's optics.

Clean with soft cloth and use normal glass to clean liquid.

Always dry the parts carefully.

Clean the external optics at least every 20 days. Clean the internal optics at least every 30/60 days.