

PURPOSE AND SCOPE

The purpose of this section is to provide a method for standardizing drawing designations for specific design requirements of molded rubber products. Information set forth on the pages that follow should be helpful to the design engineer in setting up realistic specifications for molded rubber products.

The use of proper drawing designations by designers in specifying on drawings exactly what is required is a matter of paramount importance. Proper use of these drawing designations by both product designer and rubber manufacturers will result in a common understanding of the design requirements which must be engineered into molded rubber products. To assure a uniform method for use on drawings and in specifications, the drawing designations on the following pages have been standardized by the Rubber Manufacturers Association for use in the molded rubber field.

Although rubber manufacturers can produce products to high standards of precision, they welcome the opportunity to suggest modifications which would reduce costs. The purchasers of molded rubber products can assist to this end by furnishing the manufacturers with details covering the application of their parts.

The scope of this section presents to the user the tolerances and standards the rubber manufacturers are normally able to maintain. These tolerances may be described as shown in this manual or by geometric tolerancing as shown in the ASME Y14.5M standard.

Note: Where the term “**Rubber**” is used in this section, it is intended to include synthetic thermosetting elastomers as well as natural rubber. This information may also be suitable for products made from thermoplastic elastomers.

SUMMARY AND EXAMPLES OF RMA DRAWING DESIGNATIONS MOLDED RUBBER PRODUCTS

DRAWING DESIGNATIONS

The design engineer should select and designate on the drawing a separate RMA designation for each characteristic noted. Relative dimensions, bonding, spring rate or load-deflection characteristic are to be used only when applicable. (See examples below.) If no designation is specified, the rubber manufacturer will assume that commercial tolerances apply.

Table 1 - Summary of RMA Drawing Designations

Dimensional Tolerances (Tables 2-5)	Relative Dimensions	Finish (Table 6)	Flash Extension (Table 7)		Bonding (Specify Grade and Method on B1 and B2) (Tables 8 & 9)	Load-Deflection Characteristic (Specify only when needed) (Table 10)	Packaging (Table 11)	
A1	No designation, see text and/or your rubber supplier. Specify only when needed.	F1	T.00mm	T.000	B1	D1	P1	
A2		F2	T.08mm	T.003	B2	D2	P2	
A3		F3	T.40mm	T.016	B3	D3	P3	
A4		F4	T.80mm	T.032	B4	--	--	
--		--	--	T1.60mm	T.063	B5	--	--
--		--	--	T2.35mm	T.093	--	--	--
--		--	--	T∞	T∞	--	--	--

Example 1:

Commercial tolerances; commercial finish; flash extension .80mm (.032 in.) would be designated on the drawing as follows: RMA A3-F3-T.80mm (.032 in.).

Example 2:

Precision tolerances; commercial finish; flash extension .80mm (.032 in.) and special agreement on bonding to metal would be designated on the drawing as follows: RMA A2-F3-T.80mm (.032 in.) - B5.

Example 3:

Basic tolerances; commercial finish; flash extension .80mm (.032 in.) would be designated on the drawing as follows: RMA A4-F3-T.80mm (.032 in.).

Example 4:

Precision tolerances; good finish; flash very close; (bond samples tested to 16kN/m (90 lbs./in.) width to destruction) would be designated on the drawing as follows: RMA A2-F2-T.40mm (.016 in.) - B2 Grade 1 Method B.

STANDARDS FOR DIMENSIONAL TOLERANCES

FACTORS AFFECTING TOLERANCES

Introduction

The purpose of this section is to list some of the factors affecting tolerances. In general, the degree of reproducibility of dimensions depends upon the type of tooling and rubber used, and the state of the art.

DISCUSSION OF FACTORS AFFECTING TOLERANCES

There are many factors involved in the manufacturing of molded rubber products which affect tolerances. Since these may be peculiar to the rubber industry, they are listed here.

Shrinkage

Shrinkage is defined as the difference between corresponding linear dimensions of the mold and of the molded part, both measurements being made at room temperature. All rubber materials exhibit some amount of shrinkage after molding when the part cools. However, shrinkage of the compound is also a variable in itself and is affected by such things as material specification, cure time, temperature, pressure, inserts, and post cure. The mold designer and the compounder must determine the amount of shrinkage for the selected compound and incorporate this allowance into the mold cavity size. Even though the mold is built to anticipate shrinkage, there remains an inherent variability which must be covered by adequate dimensional tolerance. Shrinkage of rubber is a volume effect. Complex shapes in the molded product or the presence of inserts may restrict the lineal shrinkage in one direction and increase it in another. The skill of the rubber manufacturer is always aimed at minimizing these variables, but they cannot be eliminated entirely.

Mold Design

Molds can be designed and built to varying degrees of precision, but not at the same cost. With any type of mold, the mold builder must have some tolerance, and therefore, each cavity will have some variance from the others. Dimensional tolerances on the product must include allowances for this fact. The accuracy of the mold register must also be considered. This is the matching of the various plates of the mold that form the mold cavity. Register is usually controlled by dowel pins and bushings or by self-registering cavities. For molds requiring high precision in dimensions and register, the design work and machining must be more precise and the cost of the molds will be greater than one with commercial requirements.

Trim and Finish

The objectives of trimming and finishing operations are to remove rubber material -- such as flash, which is not a part of the finished product. Often this is possible without affecting important dimensions, but in other instances, some material is removed from the part itself. Where thin lips or projections occur at a mold parting line, mechanical trimming may actually control the finished dimension.

Inserts

Most insert materials (metal, plastic, fabric, etc.) have their own standard tolerances. When designing inserts for molding to rubber, other factors must be considered, such as fit in the mold cavities, location of the inserts with respect to other dimensions, proper hole spacing to match with mold pins, and the fact that inserts at room temperature must fit into a heated mold. In these matters, the rubber manufacturer can be of service in advising on design features.

Distortion

Because rubber is a flexible material, its shape can be affected by temperature. Distortion can occur when the part is removed from the mold or when it is packed for shipment. This distortion makes it difficult to measure the parts properly. Some of the distortion can be minimized by storing the part as unstressed as possible for 24 hours at room temperature. Some rubber will crystallize (stiffen) when stored at low temperature and must be heated to above room temperature to overcome this condition.

Environmental Storage Conditions

Temperature: Rubber, like other materials, changes in dimension with changes in temperature. Compared to other materials the coefficient of expansion of rubber is high. To have agreement in the measurement of products that are critical or precise in dimension, it is necessary to specify a temperature at which the parts are to be measured and the time required to stabilize the part at that temperature.

Humidity: Some rubber materials absorb moisture. Hence the dimensions are affected by the amount of moisture in the product. For those products which have this property, additional tolerance must be provided in the dimensions. The effect may be minimized by stabilizing the product in an area of controlled humidity and temperature for a period not less than 24 hours.

Dimension Terminology

The following will provide a common terminology for use in discussing dimensions of molded rubber products, and for distinguishing various tolerance groupings:

Fixed Dimension: Dimensions not affected by flash thickness variation. (Mold Closure) See Figure #1.

Closure Dimensions: Dimensions affected by flash thickness variation. (Mold Closure) See Figure #1.

Figure 1

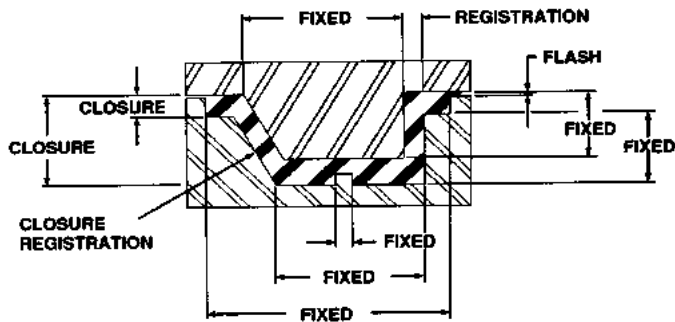

In addition to the shrinkage, mold maker's tolerance, trim and finish, a number of other factors affect closure dimensions. Among these are flow characteristics of the raw stock, weight, shape of preform and molding process.

While closure dimensions are affected by flash thickness variation, they are not necessarily related to basic flash thickness. If a manufacturer plans to machine or die trim a product, the mold will have a built-in flash, which will be thicker than if hand deflashing or tumble trim were to be employed. Thus products purchased from two sources could have different basic flash thickness at the parting line and yet meet drawing dimensions.

There is usually a logical place for the mold designer to locate the parting line for best dimensional control and part removal. If the product design limits this location, an alternate mold construction will be required, which may affect the tolerance control on the product, and may, in some cases, increase the cost of the mold.

Registration Dimension: Dimensions affected by the matching of the various plates of the mold that form the mold cavity. Register is usually controlled by dowel pins and bushings or by self-registering cavities.

TOLERANCE TABLES

There are four levels of dimensional tolerances that are used for molded rubber products.

"A1"	High Precision
"A2"	Precision
"A3"	Commercial
"A4"	Basic

The level selected should be based upon the need with the following guidelines.

"A1" is the tightest tolerance classification and indicates a high precision rubber product. Such products require expensive molds, fewer cavities per mold, costly in-process controls and inspection procedures. It is desirable that the exact method of measurement be agreed upon between rubber manufacturer and customer, as errors in measurement may be large in relation to the tolerance. Some materials, particularly those requiring post curing, do not lend themselves to Drawing Designation "A1" tolerances.

"A2" tolerances indicate a precision product. Molds must be precision machined and kept in good repair. While measurement methods may be simpler than the Drawing Designation "A1", careful inspection will usually be required.

"A3" tolerances indicate a "commercial" product and will normally be used for most products.

"A4" tolerances apply to products where some dimensional control is required but is secondary to cost.

When applying tolerances the following rules should be kept in mind.

1. Fixed dimension tolerances apply individually to each fixed dimension by its own size.
2. Closure dimension tolerances are determined by the largest closure dimension and this single tolerance is used for all other closure dimensions.
3. Fixed and closure dimensions for a given table do not necessarily go together, and can be split between tables.
4. Tolerances not shown should be determined in consultation with the rubber manufacturer.
5. Care should be taken in applying standard tolerances to products having wide sectional variations.

**Table 2 - Standard Dimensional Tolerance Table
Molded Rubber Products Drawing Designation "A1" High Precision**

Size (mm)		Fixed	Closure	Size (inches)		Fixed	Closure
Above	Incl.			Above	Incl.		
0	- 10	±.10	±.13	0	- .40	±.004	±.005
10	- 16	.13	.16	.40	- .63	.005	.006
16	- 25	.16	.20	.63	- 1.00	.006	.008
25	- 40	.20	.25	1.00	- 1.60	.008	.010
40	- 63	.25	.32	1.60	- 2.50	.010	.013
63	- 100	.32	.40	2.50	- 4.00	.013	.016
100	- 160	.40	.50	4.00	- 6.30	.016	.020

**Table 3 - Standard Dimensional Tolerance Table
Molded Rubber Products Drawing Designation "A2" Precision**

Size (mm)		Fixed	Closure	Size (inches)		Fixed	Closure
Above	Incl.			Above	Incl.		
0	- 10	±.16	±.20	0	- .40	±.006	±.008
10	- 16	.20	.25	.40	- .63	.008	.010
16	- 25	.25	.32	.63	- 1.00	.010	.013
25	- 40	.32	.40	1.00	- 1.60	.013	.016
40	- 63	.40	.50	1.60	- 2.50	.016	.020
63	- 100	.50	.63	2.50	- 4.00	.020	.025
100	- 160	.63	.80	4.00	- 6.30	.025	.032
160	- & over			6.30	& over		
	multiply by	.004	.005		multiply by	.004	.005

**Table 4 - Standard Dimensional Tolerance Table
Molded Rubber Products Drawing Designation "A3" Commercial**

Size (mm)		Fixed	Closure	Size (inches)		Fixed	Closure
Above	Incl.			Above	Incl.		
0	- 10	±.20	±.32	0	- .40	±.008	±.013
10	- 16	.25	.40	.40	- .63	.010	.016
16	- 25	.32	.50	.63	- 1.00	.013	.020
25	- 40	.40	.63	1.00	- 1.60	.016	.025
40	- 63	.50	.80	1.60	- 2.50	.020	.032
63	- 100	.63	1.00	2.50	- 4.00	.025	.040
100	- 160	.80	1.25	4.00	- 6.30	.032	.050
160	- & over			6.30	& over		
	multiply by	.005	.008		multiply by	.005	.008

**Table 5 - Standard Dimensional Tolerance Table
Molded Rubber Products Drawing Designation "A4" Basic**

Size (mm)		Fixed	Closure	Size (inches)		Fixed	Closure
Above	Incl.			Above	Incl.		
0	- 10	±.32	±.80	0	- .40	±.013	±.032
10	- 16	.40	.90	.40	- .63	.016	.036
16	- 25	.50	1.00	.63	- 1.00	.020	.040
25	- 40	.63	1.12	1.00	- 1.60	.025	.045
40	- 63	.80	1.25	1.60	- 2.50	.032	.050
63	- 100	1.00	1.40	2.50	- 4.00	.040	.056
100	- 160	1.25	1.60	4.00	- 6.30	.050	.063
160	- & over			6.30	& over		
	multiply by	.008	.010		multiply by	.008	.010

Measurement of Dimensions

Conditioning of Parts: Measurements of dimensions shall be made on parts conditioned at least 24 hours after the molding operation. Measurements shall be completed within 60 days after shipment or before the part is put into use, whichever is the shorter time. Care shall be taken to ensure that the parts are not subjected to adverse storage conditions.

In the case of referee measurement, particularly on Drawing Designation "A1" tolerances or for materials known to be sensitive to variations in temperature or relative humidity, the parts in question should be conditioned for a minimum of 24 hours at $23^{\circ} \pm 2^{\circ} \text{ C}$ ($73.4^{\circ} \pm 3.6^{\circ} \text{ F}$) and at $50\% \pm 5\%$ relative humidity.

Methods of Measurement: Depending upon the characteristics of the dimension to be measured, one or more of the following methods of measurement may be used.

- (A) A coordinate measuring machine (CMM) with a stylus size appropriate for the smallest feature or dimension to be measured.
- (B) A dial micrometer with a plunger size and loading as agreed upon by the customer and the rubber manufacturer.
- (C) A suitable optical measuring device.
- (D) Fixed gauges appropriate to the dimensions being measured.
- (E) Other methods agreed on between customer and supplier.

Under no circumstances should the part be distorted during measurement. On dimensions which are difficult to measure or which have unusually close tolerances, the exact method of measurement should be agreed upon in advance by the rubber manufacturer and the customer.

Relative Dimensions

General Information: Relative dimensions such as concentricity, squareness, flatness, parallelism, or location of one or more inserts in the product are dimensions described in relation to some other dimension. Since it is impossible to foresee the many potential designs of all molded products in which relative dimensions will be specified, it is impractical to assign standard drawing tolerance designations to these dimensions. The design engineer should recognize that the more precise the requirement, the more expensive the product. He must allow the rubber manufacturer to use support pins, lugs, chaplet pins, or ledges in the mold to provide positive location and registration of the insert or inserts in the mold cavity. With this in mind, it is suggested that the design engineer discuss relative dimensional tolerances on all products directly with the rubber manufacturer.

Other factors do affect tolerances to some minor degree. Our attempt has been to acquaint the design engineer with background information on the major factors which result in the need for tolerances on molded rubber products.

Examples of Relative Dimensions: Several examples of relative dimensions the design engineer may be required to consider are shown:

- (A) Concentricity
- (B) Squareness
- (C) Flatness
- (D) Parallelism

In all cases the tolerances should be considered only as a very general guide.

CONCENTRICITY

Concentricity is the relationship of two or more circles or circular surfaces having a common center. It is designated as T.I.R. (total indicator reading) and is the total movement of the hand of an indicator set to record the amount that a surface varies from being concentric.

All diameters formed in the same mold plate will be concentric within 0.25mm TIR (.010 in. TIR).

Example:

In Fig. #2 diameter "A" will be concentric with diameter "B" within 0.25mm TIR (.010 in. TIR)

Other diameters will be concentric within 0.75mm TIR (.030 in. TIR).

Example:

In Fig. #2 diameter "A" or "B" will be concentric with diameter "C" within 0.75mm TIR (.030 in. TIR).

Figure 2

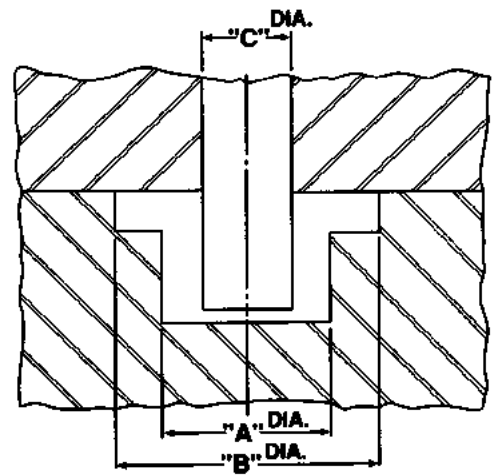

DIA. "B" NOT OVER 50mm (2 in.).

FLATNESS

Flatness of a surface on a part is the deviation from a true plane or straight edge.

Rubber Product (Unground).

Molded Surfaces (unground) will be flat within 0.25mm (.010 in.).

Example:

Fig. #7 On a cup as illustrated, the bottom can be concaved or convexed by no more than 0.25mm (.010 in.).

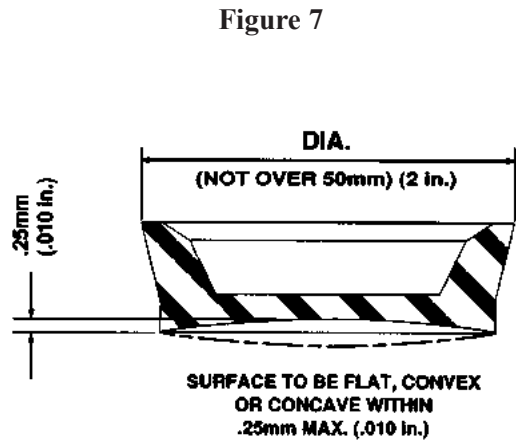

Rubber Product with Metal Insert

Surfaces that are ground after molding will be flat within 0.12mm (.005 in.). (Allowance must be made for removal of stock during grinding operation.)

Example:

In Sketch 1 Fig. #8 after molding, deviation from the true plane can be held to 0.25mm (.010 in.).

Example:

In Sketch 2 Fig. #8 after grinding, deviation can be held to 0.12mm (.005 in.) but dimension "H" will necessarily be affected.

Figure 8

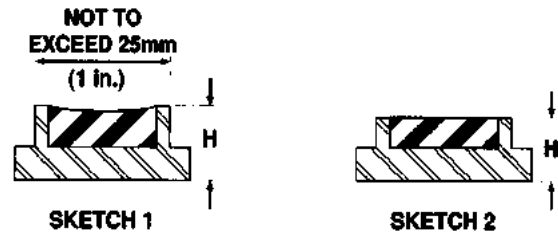

PARALLELISM

Parallelism is the relationship of surfaces in different planes. To be parallel the planes passing through the surfaces must be equidistant from each other at all points when measured at 90° to the planes.

Rubber Product with Metal Inserts.

Example:

In Sketch 1 Fig. #9 the plates of the sandwich mount are parallel. In Sketch 2 Fig. #9 they are not. On such a part approximately 200mm (8 in.) square, parallelism to within 0.75mm (.030 in.) can be expected.

Figure 9

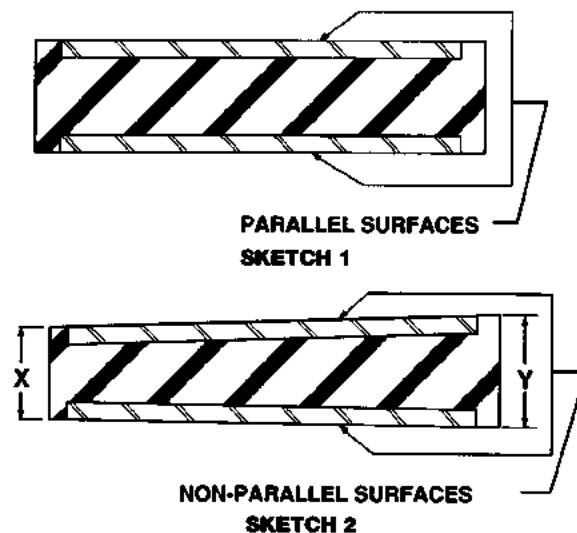

STANDARDS FOR MOLD CAVITY FINISH AND MOLDED PRODUCT APPEARANCE

Introduction

The purpose of this section is to list and discuss some of the factors that have an effect on the finish and appearance of molded products and to present standards covering four classes of finish to be applied to the mold cavity surface.

FACTORS AFFECTING FINISH AND APPEARANCE

Machined Finish of Mold

The machined finish of the mold has considerable effect on the surface finish or appearance of a rubber product.

The best finish can be obtained from a highly polished steel mold, free from all tool marks or other imperfections. Naturally, this type of mold is quite expensive to construct and maintain and is not generally required unless surface finish is of paramount importance from either an appearance or functional standpoint. In addition, it may be desirable in some cases to chrome plate the mold in order to maintain the required surface finish under production conditions.

The commercial type mold is a machined steel mold made to conform to good machine shop practice. Machine tool marks will not ordinarily be polished out of this type mold. It should be noted that regardless of how highly the mold itself is polished, the appearance of the rubber surface will depend to a large extent upon the factors outlined in the following paragraphs.

Type of Rubber Material Used

The type of rubber material used can greatly affect the appearance of the rubber product. Some compounds lend themselves to a bright glossy surface while others may be dull as molded or become dulled very easily during handling or storage. Also, there are some rubber compounds to which antiozonants are added to impede attack from ozone. As these compounds age, the antiozonants "bleed out", giving the product a colored or waxy surface, often referred to as "bloom". This is a common practice and the product should not be considered imperfect or defective in any way. This or other specification requirements may make it impossible to produce a product with a glossy surface.

Mold Release Used

There are certain rubber compounds that can be removed from the mold with the use of little or no mold release lubricant, while others require the use of a considerable quantity of mold release lubricant. The latter may have the appearance of being oily.

If the surface of the rubber product is to be bonded to other materials in its application or is to be painted, the designer should designate this on the drawing so that the manufacturer may use a mold release lubricant that will not impair adhesion quality.

Flash Removal Method

Some of the many methods used to remove flash from rubber parts may affect the appearance of the finished product. As an example, hand trimming will ordinarily have no effect, while tumbling may result in a dull surface.

Method of Designation of Finish

The symbol "F" followed by an appropriate number selected from Table 6 shall be used to designate the type of finish required.

An arc enclosing the actual area included by this designation and a leader to the finish number designates the type of finish desired. The use of a finish symbol on the surface does not preclude the possibility that other surfaces may require different finishes. However, the use of a standard notation is desirable wherever possible to eliminate the repetition of finish symbols and maintain simplicity. SEE FIG. #10.

Always permit "Commercial Finish" (F-3) whenever possible.

Figure 10

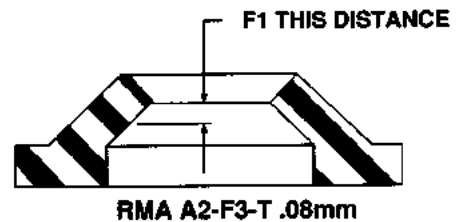

Table 6 - RMA Drawing Designation for Finish

Drawing Designation	
F1	A smooth, polished and uniform finish completely free of tool marks, dents, nicks and scratches, as produced from a highly polished steel mold. In areas where F1 is specified, the mold will be polished to a surface finish of 10 micro-inches (250nm) or better.
F2	A uniform finish as produced from a polished steel mold. In areas where F2 is specified, the mold will be polished to a surface finish of 32 micro-inches (800nm) or better but with very small tool marks not polished out.
F3	Surfaces of the mold will conform to good machine shop practice and no micro-inch finish will be specified. This is "Commercial Finish".
F4	Satin finish.

STANDARDS FOR FLASH

Introduction

It is the purpose of this section to list and discuss many of the factors that have an effect on the amount of flash, to describe the basic methods by which flash can be removed, and furnish the means by which the designer can designate on the product drawing the flash location and flash variation permissible.

Definition

(A) Flash.

Flash is excess rubber on a molded product. It results from cavity overflow and is common to most molding operations. Flash has two dimensions -- Extension and Thickness.

(B) Flash Extension.

Flash extension is the film of rubber projecting from the part along the parting line of the mold.

(C) Flash Thickness.

Flash thickness is measured perpendicular to the mold parting line. Variations in flash thickness are normally included in closure tolerances.

General Information

A method for designating permissible flash extension and thickness on a molded product will result in better understanding between rubber manufacturer and consumer and benefit both. This method must permit the designation of a surface where no parting line is permissible. It must also designate areas where a parting line is permissible and define the amount of flash extension tolerable in such areas. The designer, without specific rubber processing knowledge, should be able to specify flash extension limits in any given area on this drawing. Use of RMA Drawing Designations provided in this section will provide this capability; however, the designer should not specify how flash is to be removed. He should specify the amount of flash extension which can be tolerated without impairing product function or appearance. A method designating areas permitting flash and describing flash extension tolerance will result in the following benefits:

- (A) Avoid errors in mold design concerning parting line location.
- (B) Uniformity in appearance and function of molded products supplied by more than one source.
- (C) Simplification of inspection procedures.
- (D) Reduce over-finishing or under-finishing products.

Molding techniques have been developed to produce "flashless" products. The mold parting line, depending on location on the product, is barely discernible with no measurable thickness or extension. Initial cost and maintenance of this tooling and equipment is high and very close manufacturing control is required.

In instances where flash extension is not a problem or where it is otherwise advantageous, parts are shipped as molded with no flash removal necessary.

Methods for removing flash from products with metal or other inserts are approximately the same as for non-inserted rubber products. Rubber flash adhering tightly to inserts is generally acceptable. If it must be removed, it is done by mechanical means such as wire brushing, abrasive belts or spot facing. If adhered rubber flash is not permissible, it should be so specified on the drawing.

Flash removal is an important cost factor in producing finished molded rubber products. Cost conscious designers will permit the widest possible latitude in flash thickness, flash extension, and in location of flash consistent with adequate function and appearance of the product.

FACTORS AFFECTING FLASH

Flash Location

Parting lines (flash lines) must be located to facilitate part removal from the mold cavity after curing.

Flash Thickness

Flash thickness is determined in the molding operation and may vary with mold design, closing pressure, with weight and shape of preform, and type of compound used -- and many lesser factors. Normal variations in flash thickness have been taken into account in the tables set up for closure tolerances, and this will receive no further consideration.

The designer should be aware that heavy or thick flash is frequently designed to facilitate removal of parts from the mold and to facilitate subsequent handling. In this regard the maximum thickness that can be tolerated without impairing the product function or appearance should be specified.

Flash Extension

There are many methods by which flash extension on rubber products can be removed. The particular method selected will be determined by the degree of flash extension permitted as well as by flash location, flash thickness, and other factors. Some of the more common methods of flash removal are as follows:

(A) Buffing

A moving abrasive surface material is applied to the rubber part to remove excess rubber by abrasive action.

(B) Die Trim

A cutting tool, shaped to the contour of the molded product at the parting line, is applied with a force perpendicular to the flash extension and against either a flat plate or a fitted shape. This creates a shearing or pinching action removing the excess flash. Die trim can be done with a hand or machine mounted die. Machine mounted dies are often used for multiple trimming of small uniformly shaped products from multi-cavity molds.

(C) Machine Trim

Flash is removed by passing the rubber part through machine mounted rotating or reciprocating cutting tools. These devices are customarily adapted to a particular product and may shear, saw, or skive the flash away.

(D) Tumble Trim

There are two basic types of tumble trimming. Both utilize a rotating barrel or drum in which the heavier rubber sections strike the thinner and more fragile flash breaking it free. Dry tumbling at room temperature is most effective with the higher durometer "hard" compounds. The other type of tumbling utilizes carbon dioxide or nitrogen to freeze the molded parts, thus making the compound more brittle so the flash will break more readily. Any tumbling operation will have an effect on surface finish.

(E) Mechanical Deflashing

Modern deflashing machines utilize an abrasive medium, tumbling, and a refrigerant for quick freezing. The time and temperature are closely controlled while the parts are agitated in an enclosed barrel. Refrigerant (usually carbon dioxide or nitrogen) is metered into the deflashing chamber while the parts are being impinged with a mechanically agitated abrasive medium. The flash, being thin, freezes first and is broken away by the abrasive medium and the tumbling action before the heavier rubber part itself has lost its resiliency. Some loss of surface finish may be expected and some of the abrasive medium may adhere to the molded parts.

(F) Pull Trim or Tear Trim

A very thin flash extension is molded immediately adjacent to the part and a thicker flash is molded adjacent to the thin flash but farther from the part. When the flash is pulled from the molded part, it separates at its thinnest point adjacent to the molded part. This method may result in a sawtooth or irregular appearance and it is limited to certain compounds and product designs.

(G) Hand Trim

Flash is removed by an expedient method using hand tools such as knives, scissors, razor blades or skiving knives.

Method of Designation of Flash

Extension

The symbol "T" with a notation in hundredths of a millimeter for the maximum extension shall be used. Example: T .80mm. (.80mm maximum extension permitted.) IF ENGLISH DIMENSION THE DRAWING DESIGNATION WILL NOT BE FOLLOWED BY ANY LETTERS. EXAMPLE T .032.

Thickness

The flash thickness may be specified following the extension limit if it is critical to the function of the part. Closure tolerances will apply as in tables 2, 3, 4, and 5 on page 6.

Location

An arc enclosing the actual area included by this designation and a leader to the trim symbol designates the maximum allowable flash extension and thickness thus enclosed. If no flash can be tolerated in a given area, the symbol "T" .00mm is used. SEE FIG. #11.

Standards

The designer may indicate on his drawing any amount of maximum flash extension permissible. However, as a matter of simplicity, a progression of flash extension Drawing Designations is suggested in Table 7. Only those areas requiring such a designation should be specified. The use of a standard note can frequently be used with no further notation. SEE FIG. #11.

Figure 11

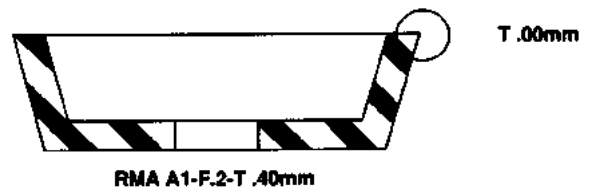

Table 7 - RMA Drawing Designation for Flash Extension

Drawing Designation	
T .00mm	(T .000) No flash permitted on area designated. (Standard notation regarding other surfaces must accompany this notation.)
T .08mm	(T .003) This tolerance will normally require buffing, facing, grinding or a similar operation.
T .40mm	(T .016) This tolerance will normally require precision die trimming, buffing or extremely accurate trimming.
T .80mm	(T .032) This tolerance will normally necessitate die trimming, machine trimming, tumbling, hand trimming, or tear trimming.
T 1.60mm	(T .063) This would be the normal tear trim tolerance.
T 2.35mm	(T .093) This tolerance will normally require die trimming, tear trimming, or hand trimming of some type.
T ∞	(T ∞) No flash limitation.

STANDARDS FOR RUBBER-TO-METAL ADHESION

Introduction

The processes of adhering rubber to metal components are widespread techniques in the rubber industry. Generally the same considerations and procedures are applicable for rubber to rigid non-metallic components, but the adhesion values may be lower. Only the broad aspects of rubber-to-metal molding are covered here, and more precise information can be provided by the rubber manufacturer involved.

GENERAL INFORMATION

Application

Various adhesion levels can be obtained. For instance, to obtain adhesion on critical products, such as engine mounts, very close controls are required, both on metal and rubber preparation. Some products may require only enough adhesion for assembly.

The adhesion level (tear/tensile strength) is directly affected by type of metal, surface preparation, non-metallic inserts, compound composition, curing conditions, and type of adhesive.

Drawings should clearly state adhesion requirements and any other factors which can explain the degree of adhesion required and the method of testing. A clear understanding between customer and rubber manufacturer is essential.

Methods of Obtaining Adhesion

The method most commonly used to obtain adhesion between rubber and metallic or non-metallic components is the use of adhesive cements. Prior to the use of these special adhesives, the surface of the insert must be clean and free of contamination.

The inserts may be prepared by suitable methods such as degreasing, blasting, and/or a suitable chemical treatment. When any one of these preparatory processes is objectionable, it should be noted on the drawing. The rubber compound is then vulcanized to the prepared inserts to obtain the desired adhesion.

Design Factors and Limitations

- Avoid localized stress raising irregularities.
- Minimize edge effects. Break, coin, or otherwise eliminate sharp edges of all metallic members covered by the rubber.



Provide fillets in the rubber at junction line with inserts where possible.

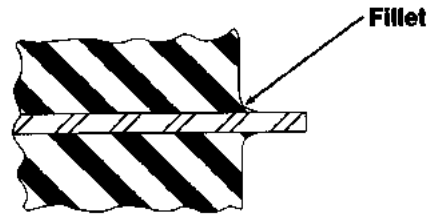

Where fillets are not possible, extend the rubber beyond the edges of the inserts which would otherwise terminate line to line with the rubber.



c. Minimize surface roughness of metallic members in area adjacent to adhered rubber.

d. Avoid welding a molded rubber component to a machine or structure to prevent unnecessary heat deterioration. When welding is mandatory, design metallic member as a heat sink and provide for assembly techniques which will keep the adhered rubber area of the metallic member below 150° C (302° F).

Test Methods for Determining Adhesion Values

Adhesion testing is done in several ways, depending upon the application and the product design. The methods recognized for this testing are treated in full detail in ASTM Test Method D 429. These methods are:

- Method A. Rubber adhered between two parallel metal plates.
- Method B. Ninety degree stripping test, rubber adhered to one metal plate.

The above methods are used primarily for laboratory development and testing production parts. These methods may be modified and applied as described under RMA Production Test Methods section as follows.

RMA PRODUCTION TEST METHODS

Method A. Used where two metal surfaces, not necessarily parallel, can be separated until the specified adhesion value is obtained using the projected adhered area. The area to be considered should be the projected active adhered working area of the smallest metallic member, excluding fillets, overedge, and radii. Very irregular areas are to be given special consideration.

Method B. Used where the rubber can be stripped from the entire width of the part to obtain a specified adhesion value or where the rubber can be cut in 25.4mm (1.0 in.) wide strips. Specimen rubber thickness shall not exceed 9.5mm (.375 in.). In rubber sections over 9.5mm (.375 in.), values should be negotiated between customer and supplier.

Acceptance Criteria

Looseness contiguous to the adhered areas at corners, fillets, mold parting lines, and back-rinding will ordinarily be acceptable.

The adhesion strength is usually considered to be satisfactory if the failure causes permanent distortion of a metallic member.

If the deformation of the rubber section under test far exceeds the functional service requirements, this factor should be taken into consideration when establishing a reasonable adhesion value.

It is recognized that conditions for adhesion will exist where a quantitative value cannot be obtained. In these instances, it is customary to pull the rubber from the metallic member and examine the nature of the failure. The acceptable degree of adhesion must be agreed upon between the customer and the rubber manufacturer. Customer's test methods and fixtures should be identical with those of the rubber manufacturer and correlation procedures established.

METHODS OF DESIGNATING ADHESION VALUES

The design engineer when writing specifications should use a designation to obtain suitable adhesion for the purpose intended.

Methods of testing, such as tension pull or shear pull (RMA Production Method "A") or 90 degree stripping (RMA Production Method "B") and the minimum destruction values, as well as the design of special testing fixtures should be specified on the drawings. ASTM D2000 -- SAE J200 has two types of adhesion designations for adhesion of vulcanized rubber to metal:

1. Adhesion by vulcanization, designated by K11 or K21.
2. Adhesion by the use of cements or adhesives after vulcanization, designated by K31.

This section is concerned only with K11 and K21.

Table 8 - RMA Drawing Designation for Rubber-To-Metal Adhesion Classification

Drawing Designation	
B1 (Specify method and grade from Table 9.)	Production 100% tested to 70% of the minimum destruction values as noted in Table 9, Method A only. In addition, sample parts tested to destruction must exceed the minimum destruction values as noted in Table 9. (Specify Method A or Method B and Grade.)
B2 (Specify method and grade from Table 9.)	Sample parts tested to destruction must exceed the minimum destruction values as noted in Table 9.
B3	Rubber to be adhered to metal. This designation would ordinarily be used on products where adhesion is not critical to product function.
B4	Mechanical attachment only. Rubber is not adhered to metal.
B5	Products requiring special consideration.

As an illustration of the above drawing designation, see Example 4 in the Summary of RMA Drawing Designations on page 3.

Table 9 - RMA Drawing Designation for Minimum Adhesion Destruction Values

Method A

Drawing Designation	S.I. Metric Units	USA Customary Units
Grade 1	2.8 MPa	400 psi
Grade 2	1.75 MPa	For rubber compounds over 10.5 MPa (1500 psi) tensile strength and 50 or greater hardness (SHORE "A") 250 psi
	1.4 MPa	For rubber compounds under 10.5 MPa (1500 psi) tensile strength or under 50 hardness (SHORE "A") 200 psi
Grade 3	0.35 MPa	50 psi

Method B

Drawing Designation	S.I. Metric Units	USA Customary Units
Grade 1	16 KN/m width	90 lbs./in. width
Grade 2	9 KN/m width	For rubber compounds over 10.5 MPa (1500 psi) tensile strength and 50 or greater hardness (SHORE "A") 50 lbs./in. width
	7 KN/m width	For rubber compounds under 10.5 MPa (1500 psi) tensile strength or under 50 hardness (SHORE "A") 40 lbs./in. width
Grade 3	2.7 KN/m width	15 lbs./in. width

As an illustration of the above drawing designation, see Example 4 in Table 1 on page 3.

Table 9 is applicable only to RMA B1 and B2 levels shown in Table 8.

All grades of adhesion cannot be obtained with all compound classifications.

Grade 2 is similar to ASTM-SAE K11 and K21.

STANDARDS FOR STATIC AND DYNAMIC LOAD DEFLECTION CHARACTERISTICS

Introduction

Primarily, rubber is used in place of metallic, ceramic, and other rigid materials because it will provide a greater deflection for a given force than these other materials. Most uses of rubber are based upon this characteristic.

In many uses of rubber, stiffness variation is not critical to the rubber product function and in such cases the Shore A durometer hardness specification is sufficient.

Rubber is used as an engineering material in resilient mountings, vibration isolators, dampers, impact pads and many similar applications. Where static or dynamic stiffness characteristics become critical to the function of the product, appropriate test specifications must be established.

METHODS AND CONSIDERATIONS

Static Methods

When a static load-deflection specification is established for a product, in addition to a hardness requirement, the load-deflection specification shall supercede the hardness, should be stated on the product drawing, and agreed upon between the customer and the rubber manufacturer. A static test is only "static" in that the load application comes to rest before the measurement is taken or the rate of deflection does not normally exceed 0.8mm/s (2 in./min.). Such a test usually places the rubber in shear or compression. There are several ways of specifying static load-deflection characteristics.

- a. Specify spring rate in load per unit deflection, e.g., N/m (lb./in.) or torque per degree, e.g. N-m/deg. (lb.-in./deg.).
- b. Specify a load to deflect the product within a specified deflection range.
- c. Specify a deflection resulting in a load within a specified load range.

Dynamic Methods

Applications where rubber is used as vibration isolators are dependent upon the behavior of the rubber under dynamic operating conditions.

Rubber is stiffer dynamically than in a static mode; and, since the static to dynamic stiffness ratio varies with individual compounds, it may be advisable to specify the dynamic characteristics of the rubber for such applications.

When dynamic stiffness or spring rate is specified, and is critical to the rubber product performance, the complete conditions and methods of measurement must be established between customer and rubber manufacturer.

There are several methods of dynamic testing:

- a. Steady State Resonance
- b. Free Decay Resonance
- c. Steady State Non-Resonant
- d. Rebound Evaluation

FACTORS AFFECTING STATIC AND DYNAMIC LOAD DEFLECTION CHARACTERISTICS

Age

The aging of rubber compounds over a period of time is a complex process. The normal net effect of aging is an increase in modulus or stiffness. The magnitude of this change is dependent upon the specific material involved and the environmental conditions.

Short term age, in the sense of the minimum number of hours which should elapse between molding and evaluation, is also a significant factor. Depending upon the nature of the product, the minimum period will vary from 24 hours to 168 hours.

Dynamic History

The load-deflection characteristics of a rubber product are affected by the work history of that specific product. The initial loading cycle on a new part, or a part that has been in a static state for a period of time, indicates a stiffer load-deflection characteristic than do subsequent cycles. In static testing this effect becomes stabilized and the load-deflection characteristics normally become repeatable after two to four conditioning cycles.

In dynamic testing, the conditioning period is normally selected as the time required to obtain reproducible results.

Temperature

Temperature has an effect on spring rate -- the higher the temperature the lower the spring rate, and the lower the temperature the higher the spring rate of a rubber product not under continuous tension.

Test Conditions

The following details must be defined by the product drawing, or referenced specification, to ensure relevant and consistent product performance evaluation:

a. Mode of Test

1. Tension, Shear or Compression. A schematic diagram depicting product orientation is highly desirable. The spring rate in the compression mode is always higher than the spring rate in the shear mode.
2. Static or Dynamic

The dynamic spring rate is always higher than the static spring rate.

b. Test Level and Control Mode

1. Static testing load level or level of deformation, together with the appropriate limits on deflection or limits of loading in response to deformation, shall be stated.

2. Dynamic load levels shall be identified by a plus (+) value for downward forces and a negative (-) value for upward forces. Dynamic tests utilizing deformation control shall be specified by double amplitude (total amplitude) values.

c. The amount and direction of preload, if required.

d. The linear or angular rate of loading or cyclic frequency.

e. The nature and number, or duration, of conditioning cycles required prior to the test cycle or test period.

f. The ambient test temperature and the period of time the product is held at test temperature prior to evaluation.

g. When the requirements are stated as “Spring Rate” the location on the load-deflection chart at which the tangent is drawn, or the load levels between which an average is taken, must be indicated.

METHODS OF DESIGNATING STATIC & DYNAMIC TOLERANCES

When applicable, the design engineer must specify load-deflection, spring rate, method of test and load-deflection tolerances. Table 10 presents standards for the three drawing designations for load-deflection tolerances. If damping, characteristics are required as a part of a dynamic specification, commercial tolerances would be $\pm 25\%$ on parts up through 65 durometer hardness (SHORE A) and $\pm 30\%$ for above 65 durometer hardness (SHORE A).

Table 10 - RMA Drawing Designations for Load-Deflection Tolerance

Drawing Designation	Durometer Hardness	Tolerance Range Rubber Wall Thickness 6mm (0.25 in.) or over	Tolerance Range Rubber Wall Thickness under 6mm (0.25 in.)	
D1	65 Durometer Hardness (Shore A) or below	$\pm 10\%$	$\pm 15\%$	Very high precision. This close tolerance should only be requested in unusual circumstances.
	Above 65 Durometer Hardness (Shore A)	$\pm 15\%$	$\pm 20\%$	
D2	65 Durometer Hardness (Shore A) or below	$\pm 11\%$ to $\pm 14\%$	$\pm 16\%$ to $\pm 20\%$	Precision
	Above 65 Durometer Hardness (Shore A)	$\pm 16\%$ to $\pm 19\%$	$\pm 21\%$ to $\pm 26\%$	
D3	65 Durometer Hardness (Shore A) or below	$\pm 15\%$	$\pm 20\%$	Commercial
	Above 65 Durometer Hardness (Shore A)	$\pm 20\%$	$\pm 25\%$	

STANDARDS FOR PACKAGING

When a rubber part is packaged, it is for the sole purpose of transportation from the supplier to the user. Packaging usually causes some distortion of the rubber part which, if used in a reasonable length of time, does not permanently affect the part. However, when rubber parts are held in a distorted position for a prolonged period of time, permanent set may cause permanent distortion and result in unusable parts. Any product on which distortion may make the part unusable should be specified and packaged by such methods as will prevent distortion. However, such methods are sometimes costly and should not be specified unless absolutely necessary. When distortion is a problem, the product should be removed from the container when received and stored on shelves or in a manner to preserve usability. Packaging is a complex area and should be given serious consideration. Table 11 at right is to be considered only as a guide. Special packaging problems should be considered between purchaser and supplier.

Table 11 - Packaging

Drawing Designation	
P1	This class of product will be packaged to eliminate all possible distortion during transportation and storage. This may require special boxes, cartons, forms, cores, inner liners, or other special methods.
P2	This class of product will be packaged in corrugated containers or boxes. The quantity of the product packaged per container will be held to an amount which will not crush the lower layers from its own weight, but no forms, cores, inner liners, etc., are necessary.
P3	This class of product will be packaged in corrugated paper containers, boxes, crates, burlap bags or bundles, or on skids and pallets. This is the most economical method of packaging but may also produce the greatest distortion in the product.

PURPOSE AND SCOPE

The purpose of this section is to outline in usable and easily understood form the methods used in the manufacture of a dense extruded rubber product, the problems that can arise from these methods and how they affect the finished product. By presenting this side of the process to the user he will be more adequately prepared to convey to the rubber supplier his needs and requirements. He will also be better able to understand the limits and tolerances that can normally be expected of this type product.

It is also the purpose of this section to improve the relationship of supplier and user through the use of common and meaningful terms and symbols (RMA Designations). Through this better understanding and the proper use of RMA Designations by the user, the manufacturer should be better able to supply the needs of the user thereby giving him better economy and satisfaction.

Certain statements and tables in this chapter have been changed to reflect current industry practices and to agree with International Standard ISO 3302-1:1996, Rubber -- Tolerances for products -- Part 1: Dimensional tolerances.

The information in this chapter is not intended to apply to thermoplastic elastomers.

PRINCIPLES OF EXTRUSION

An extruded rubber product differs from a molded rubber product in that the rubber is forced through a die of the desired cross-section under pressure from an extruder. The extruded product leaves the extruder in a soft pliable unvulcanized state. The extruded product normally must be vulcanized before it is usable.

Unvulcanized rubber compound is fed into the extruder. The flutes of the revolving screw carry the rubber forward to the die, building up pressure and temperature as it advances toward the die. The rubber is forced through the die by this pressure and swells in varying amounts depending on the type and hardness of the compound. Due to the many variables such as temperature, pressure, etc., the extrusion varies in size as it leaves the die, thus requiring plus or minus tolerances on the cross-section. During the vulcanization, the extrusion will swell or shrink in the cross-section and length depending on the compound used. After vulcanization, a length of extrusion has a tendency to be reduced in dimension more in the center of the length than the ends.

The extruded product is vulcanized either in a heated pressure vessel (static vulcanization) or by the continuous vulcanization process. A brief description of each follows:

STATIC VULCANIZATION

The extrusion is conveyed from the extrusion machine to a station where it is cut to varying lengths depending on the finished length and placed on a metal pan in a free state; that is, it is not contained in a cavity as in molding. The part is then vulcanized in a heated pressure vessel known as an autoclave. Generally the

autoclave is heated by steam which is allowed to fill the autoclave, building up the required temperature, which then vulcanizes the rubber into its usable form. This is known as open steam vulcanizing. The pressure surrounding the extrusion during open steam curing minimizes porosity in the extrusion.

CONTINUOUS VULCANIZATION

The extrudate is fed into the vulcanization process directly from the extruder permitting the extrusion to be vulcanized in a continuous length. Several media are employed in the continuous vulcanization of rubber, all of which must be operated at elevated temperatures: air, molten salts, oils, fluidized beads, and microwave. Microwave is a method whereby the extrudate is subjected to high frequency electro magnetic waves which raises the temperature of the extrusion to near curing state, uniformly throughout. The lack of pressure in most continuous vulcanization processes makes porosity in the extrusion difficult to control. For most rubber compounds the open cure process is most practical.

A great many variables are encountered in the extrusion process which make it necessary to require tolerances more liberal than molded parts. A design engineer should have a general knowledge of the extrusion process and its variables to enable him to design parts that can be extruded at reasonable cost.

PROCESS ILLUSTRATIONS

RUBBER EXTRUDING SYSTEMS

The systems shown below are a few variations of vulcanizing extruded rubber.

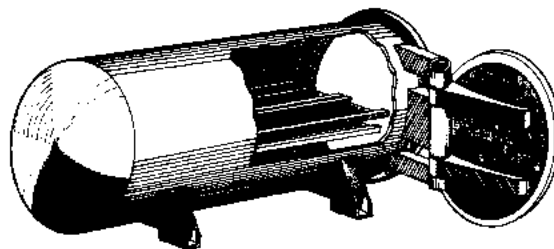

AUTOClave FOR OPEN STEAM VULCANIZATION

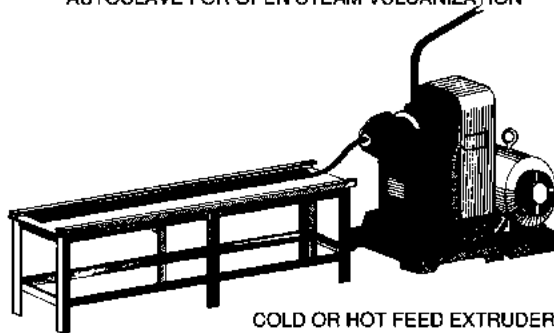

COLD OR HOT FEED EXTRUDER

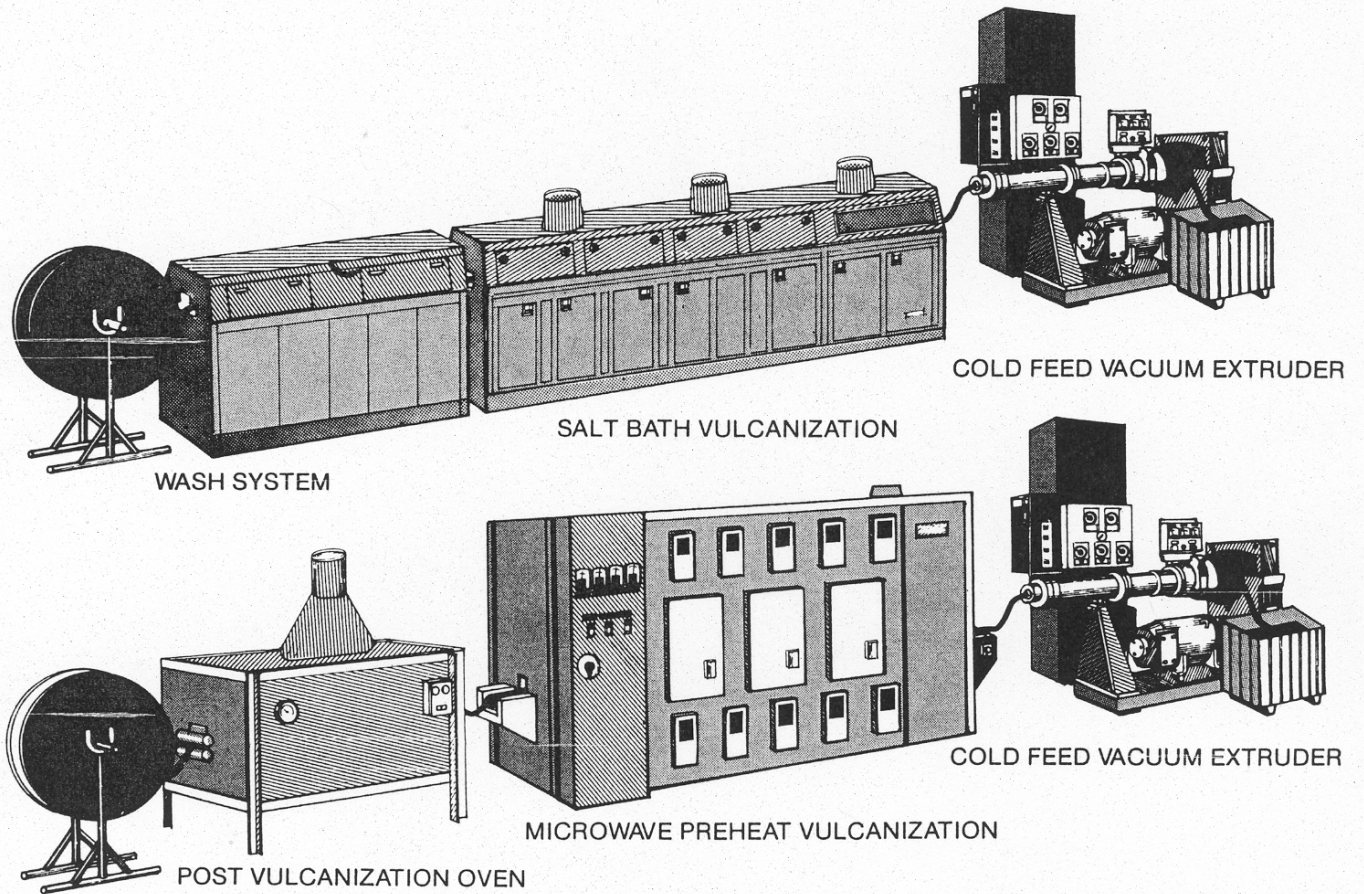

EXTRUSION DIE

The extrusion die is a precise tool which is made by cutting an opening through a blank of steel; the opening is shaped to form the rubber into the desired cross-section as it is forced through the die by the pressure from the revolving screw of the extruder. Most rubber compounds swell and increase in dimension coming through the die orifice. The die, by necessity, is made for a particular extruder and a particular compound.

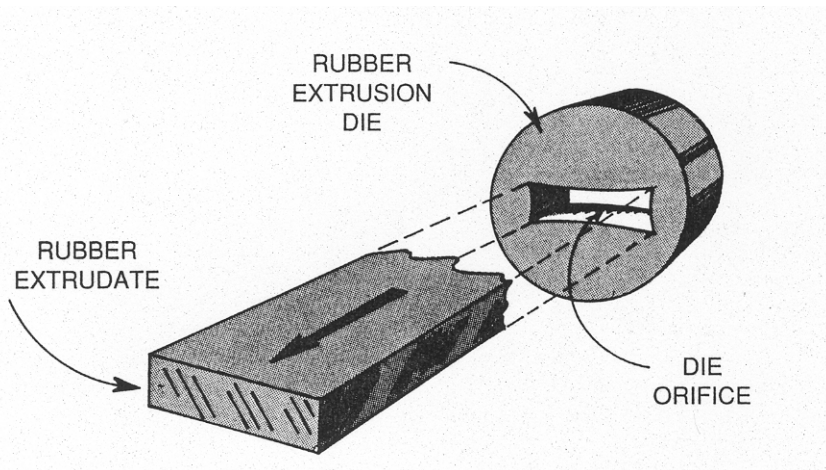

SUMMARY OF RMA DRAWING DESIGNATIONS FOR EXTRUDED RUBBER PRODUCTS

Drawing Designations

In those cases where the design engineer can specify and accept one RMA Class on extruded products for the applicable qualifications on dimensional tolerances, ground surface, mandrel vulcanization, cut length, contour, forming, finish, T.I.R. and packaging, then the drawing need only carry the symbol for the acceptable class as RMA Class 1-2-3 or 4 as the case may be.

Normally, however, there will be exceptions to an RMA Class. By using the following chart, these exceptions can be noted.

Table 12 - Summary of RMA Drawing Designations - Extruded Rubber Products

RMA Class	Dimensional Tolerance* Table 13	Finish Table 14	Formed Tubing Table 15	Cut Length Tolerance* Table 16	Angle Cut Tolerance Table 17	Spliced Length Tolerance Table 18
1	E1	F1	H1	L1	AG1	S1
2	E2	F2	H2	L2	AG2	S2
3	E3	F3	H3	L3	AG3	S3
4	--	F4	H4	--	--	--

RMA Class	Ground Surface* Table 19	Mandrel Cured* Table 20	T.I.R. Table 21	Ground Tubing Tolerance* Table 22	Packaging Table 23
1	EG1	EN1	K1	EW1	P1
2	EG2	EN2	K2	EW2	P2
3	--	EN3	--	--	P3
4	--	--	--	--	--

*As noted in the purpose and scope, certain statements and tables in this chapter have been changed to reflect current industry practices and to agree with International Standard ISO 3302-1:1996, Rubber -- Tolerances for products -- Part 1: Dimensional tolerances.

Distortion

Because rubber is a flexible material affected by temperature, distortion can occur when the part is stored or when it is packed for shipment. This distortion makes it difficult to measure the parts properly. Some of the distortion can be minimized by storing the parts as unstressed as possible for 24 hours at room temperature.

Environmental Storage Conditions

Temperature

Rubber, like other materials, changes in dimension with changes in temperature. Compared to other materials the coefficient of expansion of rubber is high. To have agreement in the measurement of products that are critical or precise in dimension, it is necessary to specify a temperature at which the parts are to be measured and the time required to stabilize the part at that temperature.

Humidity

Some rubber materials absorb moisture. Hence the dimensions are affected by the amount of moisture in the product. For those products which have this property, additional tolerance must be provided in the dimensions. The effect may be minimized by stabilizing the product in an area of controlled humidity and temperature for a period not less than 24 hours.

STANDARDS FOR CROSS SECTIONAL TOLERANCES

The following illustrations should be taken into consideration when designing rubber parts and when describing what is needed and expected from the manufacturer.

Extrusion Contour (Shape) Variation

Contour designates the degree of rigidity and conformity to the cross sectional drawing. During vulcanization the tendency of the extrusion is to sag and flatten. The degree of change in shape is largely dependent upon the hardness or softness of the compound, the tensile strength or quality of the compound, the thickness or thinness of the cross sectional wall, the inner openings of the extrusion and the rate of vulcanization. This tendency to distort during vulcanization can best be eliminated by the use of forms or mandrels which generally add to the cost of manufacture. This cost can sometimes be eliminated if contour conformity is not necessary to the finished extrusion. The degree of allowable collapse or sag in a cross section should be indicated on the blueprint as shown in illustrations below.

Figure 12

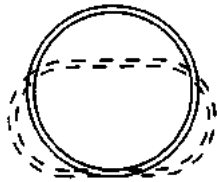

Tube may collapse as indicated by dotted line.

Figure 13



Lip may collapse as indicated by dotted line.

Squareness & Flatness of Rectangular Cross Sections

Tolerances for squareness and flatness of extruded sections are not included in these tables. Due to the difficulty of establishing meaningful limits to satisfy the wide area of needs, purchaser and manufacturer should discuss and agree on these limits.

Illustration is for enlightenment only.

Figure 14

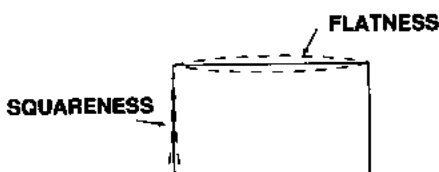

Cross Sectional Dimension Illustration.

Tolerances for illustration are taken from Class 2, Table 13, page 23.

Figure 15

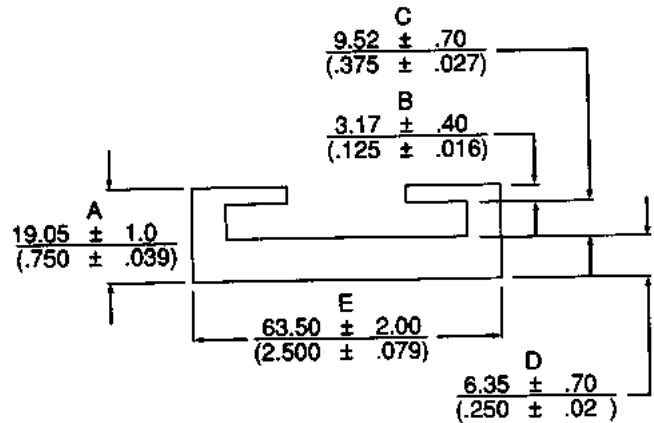

Dimension "C" in above illustration is affected by shape variation.

I.D. - O.D. Tube Tolerances

Tolerances should be established on the I.D. (or O.D.) and wall thickness only. To include a tolerance on both I.D. and O.D. generally conflicts with the other tolerances.

Figure 16

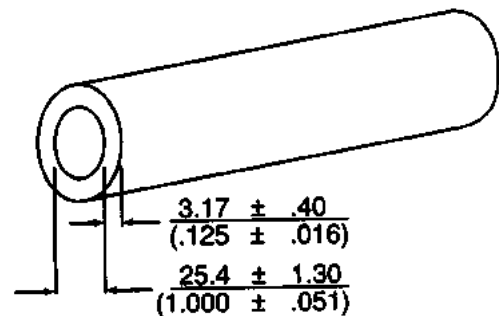

Tolerances for I.D. - O.D. tubing are found in Table 13, page 23.

STANDARDS FOR CROSS SECTIONAL TOLERANCE TABLE

The closer tolerance classes outlined below should not be specified unless required by the final application and they should be restricted to critical dimensions. The closer tolerances demanded, the tighter the control which must be exercised during manufacture and hence higher costs.

When particular physical properties are required in the product, it is not always possible to provide them in a combination which is capable of fabrication to close tolerances. It is necessary, in these circumstances, that consultation take place between the customer and supplier. In general, softer materials need greater tolerances than harder ones. Where close tolerances are required, a specific technique of measurement should be agreed upon between purchaser and manufacturer.

Table 13

Tolerances for outside (O.D.) diameters, inside (I.D.) diameters, wall thickness, width, height, and general cross sectional dimensions or extrusions...see Figures 15 and 16, Page 22.

RMA Class	1 High Precision	2 Precision	3 Commercial
Drawing Designation	E1	E2	E3
Dimensions (in Millimeters)			
Above 0	±0.15	±0.25	±0.40
Up to 1.5	0.20	0.35	0.50
1.5	0.25	0.40	0.70
2.5	0.35	0.50	0.80
4.0	0.40	0.70	1.00
6.3	0.50	0.80	1.30
10.0	0.70	1.00	1.60
16.0	0.80	1.30	2.00
25.0	1.00	1.60	2.50
40.0	1.30	2.00	3.20
63.0	1.30	2.00	3.20

RMA Class	1 High Precision	2 Precision	3 Commercial
Drawing Designation	E1	E2	E3
Dimensions (in Inches)			
Above 0.00	±0.006	±0.010	±0.015
Up to 0.06	0.008	0.014	0.020
0.06	0.010	0.016	0.027
0.10	0.014	0.020	0.031
0.16	0.016	0.027	0.039
0.25	0.020	0.031	0.051
0.39	0.027	0.039	0.063
0.63	0.031	0.051	0.079
0.98	0.039	0.063	0.098
1.57	0.051	0.079	0.126
2.48	0.051	0.079	0.126

Note: Tolerances on dimensions above 100mm (3.94 in.) should be agreed on by supplier and user. General cross sectional dimensions below 1mm (0.04 in.) are impractical.

In general, softer materials and those requiring a post cure need greater tolerances.

STANDARDS FOR EXTRUDED FINISH AND APPEARANCE

In the process of producing extruded parts, it is necessary to use various lubricants, release agents, dusting agents, and other solutions. It may be necessary to remove these materials from the extrusion after vulcanization because of an appearance requirement. The cost of cleaning may be eliminated from those products which are concealed or do not hinder assembly. The purchaser's intent and desire in this area should be conveyed to the rubber manufacturer by use of the proper RMA class of finish designation. Full consideration of finish requirements may result in considerable cost savings on the product.

Table 14 - Drawing Designation for Extrusion Finish

RMA Class	Drawing Designation	
1	F1	Product shall have surface finish smooth, clean and free from any foreign matter.
2	F2	Product shall have surface finish cleaned of dust and foreign matter but slight streaks or spots acceptable.
3	F3	Product shall have loose dust and foreign matter removed but natural finish (not washed) acceptable.
4	F4	Product shall be acceptable with no cleaning necessary. Dust or solution deposits acceptable. Coarse or grainy surface acceptable.

STANDARDS FOR FORMED TUBING (FOR SPECIAL SHAPES)

The type of product discussed in this section is formed by forcing unvulcanized tubing over a mandrel or flexible core bent to the required radii or shape.

In forcing the unvulcanized tubing over the mandrel or flexible core and around a bend, the wall thickness will be stretched on the outside of the bend and compressed on the inside of the bend. If the bend or radius is too severe, folds or wrinkles will form on the inside of the bend and severe stretching will occur on the outside of the bend.

The minimum bending radius at which tubing may be formed will depend upon the outside diameter and wall thickness and should never be less than 150% of the outside diameter (O.D.).

If a small radius or a specific angle is required, the part should be molded. This is necessary because, in addition to folds and wrinkles on the inside of the radius, it may be impossible to force the tubing over the bend or to strip it from the mandrel during the manufacturing process.

If a minimum wall thickness is specified, it will mean this minimum thickness must be furnished at the outside bend or stretched section, and depending on the severity of the bend or bends, it will require an oversize wall thickness on the rest of the tubing from 0.40mm (0.016 in.) to 0.80mm (0.032 in.) to ensure the minimum thickness on the stretched area. If tubing is specified, it must be understood that, depending on the severity of the bend or bends, wall thickness will be from 0.40mm (0.016 in.) to 0.80mm (0.032 in.) undersize in the stretched areas.

Figure 17

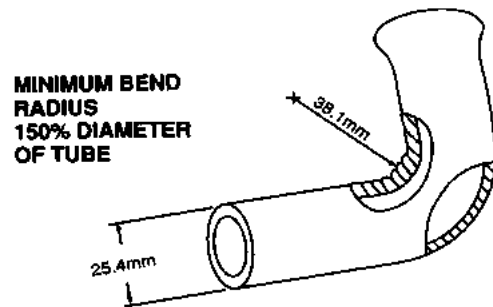

EXAMPLE OF RADIUS, STRAIGHT END, FLARED END, WRINKLES, BUCKLES AND WALL THICKNESS. MINIMUM BEND RADIUS.

Figure 18

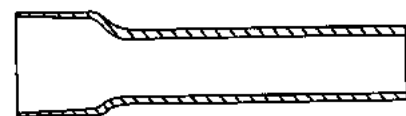

EXAMPLE OF BLENDED CONTOUR

Figure 19

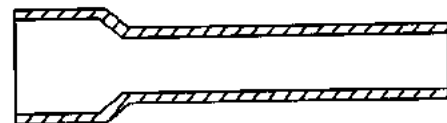

EXAMPLE OF DEFINITE CONTOUR

The leading end of the tubing will stretch and enlarge as it is forced over the mandrel or flexible core, according to the severity of the bend or bends, and will not fully recover to original size during vulcanization. If both ends of the formed tubing must meet specification set forth for the original cross section, the product should either be molded or the lead end should be designed to fit a 1.6mm (0.063 in.) oversize fixture. If the straight section adjacent to any sharp bend is to be shorter than 300% of the O.D. of the tube, it must be understood that the tube must be made long enough to eliminate the flare and cut back to desired length after removal from mandrel. When forming tubing all bends and radii must be approximate, as natural spring-back of tubing formed under tension precludes the possibility of holding to an exact radius or shape. The tubing being flexible will adjust itself on assembly to compensate for these small variations. Measurement from beginning of bends or radii to other bends and radii are also approximate and subject to small variations for the same reasons.

Where expanded ends are required, the inside and outside of the tubing should blend from the regular cross section to the expanded cross section and not with a definite contour and radius as formed on a molded part. The walls of the enlarged section will be thinner than the regular section by 0.40mm (0.016 in.) to 0.80mm (0.032 in.), depending on the severity of enlargement. Expansion beyond 100% of I.D. of tubing is not practical. Any requirements beyond 100% must be molded.

Table 15 - Drawing Designation for Formed Tubing

RMA Class	Drawing Designation	
1	H1	Product to be furnished to minimum wall thickness specified and maintained throughout. Ends to be trimmed true and even.
2	H2	Product to be furnished to general cross section with stretched or thinner wall acceptable at bends or radii. Otherwise, same as Class 1.
3	H3	Product may be furnished partially out of round in straight or bent sections. Ends may not necessarily be straight and true. Minor flat spots permissible.
4	H4	Product may be furnished partially out of round in straight or bent sections. Flat spots and slight wrinkles or buckles permissible. Product may be cut to length in unvulcanized state. (Allow 12.3mm (.500 in.) for every 750mm (30 in.) of length.) Special tolerance to be established between supplier and purchaser.

STANDARDS FOR CUT LENGTH TOLERANCES FOR UNSPLICED EXTRUSIONS

Unspliced extrusions are classified as those that generally require only extruding, vulcanizing and cutting to length. They are of various cross sectional designs and do not include lathe cut parts, formed tubing, or precision ground and cut parts. They are generally packed in a straight or coiled condition after being measured and cut to length.

The following tables are to be used to convey to the manufacturer the limits that are desired by the purchaser.

It should be understood by the design engineers that due to the stretch factor in rubber, a period of conditioning at room temperature must be allowed before measurements for length are taken. Accurate measurement of long lengths is difficult because they stretch or compress easily. Where close tolerances are required on long lengths, a specific technique of measurement should be agreed upon between purchaser and manufacturer.

Table 16 - Cut Length Tolerance Table for Unspliced Extrusion

RMA Class		1 (Precision)	2 (Commercial)	3 (Non-Critical)
Drawing Designation		L1	L2	L3
Length (in Millimeters)				
Above 0	Up to 40	±0.7	±1.0	±1.6
40	63	0.8	1.3	2.0
63	100	1.0	1.6	2.5
100	160	1.3	2.0	3.2
160	250	1.6	2.5	4.0
250	400	2.0	3.2	5.0
400	630	2.5	4.0	6.3
630	1000	3.2	5.0	10.0
1000	1600	4.0	6.3	12.5
1600	2500	5.0	10.0	16.0
2500	4000	6.3	12.5	20.0
4000		0.16%	0.32%	0.50%
Length (in Inches)				
Above 0	Up to 1.6	±0.03	±0.04	±0.06
1.6	2.5	0.03	0.05	0.08
2.5	4.0	0.04	0.06	0.10
4.0	6.3	0.05	0.08	0.13
6.3	10.0	0.06	0.10	0.16
10.0	16.0	0.08	0.13	0.20
16.0	25.0	0.10	0.16	0.25
25.0	40.0	0.13	0.20	0.40
40.0	63.0	0.16	0.25	0.50
63.0	100.0	0.20	0.40	0.63
100.0	160.0	0.25	0.50	0.80
160.0		0.16%	0.32%	0.50%

Note: Special consideration on tolerances will have to be given to both extremely soft and high tensile stocks.

STANDARDS FOR ANGLE CUT TOLERANCES FOR EXTRUSIONS

Many methods are employed to cut extruded sections to length: circular knife, rotating knife, guillotine, shear, saw and hand knife.

The angle and curve on cut face of extrusion will differ in degree depending upon the method used to cut the extrusion as well as the hardness of the compound, design or cross section and thickness of the extrusion.

(The force of the knife upon the extrusion at the line of penetration deforms the extrusion resulting in a curved surface and an angle cut.)

Table 17

Angle (AG) Tolerances		
RMA Class	Drawing Designation	Cut (Max)
Precision	AG1	4°
Commercial	AG2	6°
Non-Critical	AG3	10°

Figure 20

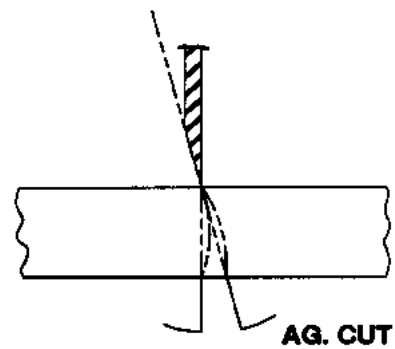

STANDARDS FOR SPLICED EXTRUSIONS

Testing Procedure

The manufacture of extrusions in circular or rectangular shaped gaskets, or a combination of both, can be accomplished by means of butt or corner vulcanized splices. The splice is usually never as strong as the original material from which the gasket is made. The stronger the splice is required to be, the more difficult the labor operations. A pressure mark will appear at the splice area due to required holding pressure in the mold. Glass and metal channels will be open at the corners 50mm (2 in.) to 75mm (3 in.) from the corner as a result of the forming plates of the mold. These will generally be open from 50% to 75% of the base of the channel. (See Figure 21.)

Figure 21

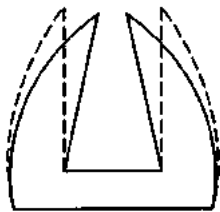

Open as indicated by Dotted Lines

The method of testing splices should be given serious consideration. The doubling over, pinching and the twisting of a splice or bending back on a corner splice are not proper methods of testing. Because of the wide variety in the types of cross sections, splice strength is very difficult to define.

Splice strength varies due to configuration of the cross section. Transfer and injection splices are stronger than butt splice joints.

Pulling perpendicular to the plane of the splice is a sufficient test in the testing of a corner splice. The gasket should be clamped in such a way that the pull is evenly distributed over the splice and not have most of the stress on the inside corner. For injection splice, see Figure 22 and for 45° corner splice, see Figure 23.

Figure 22

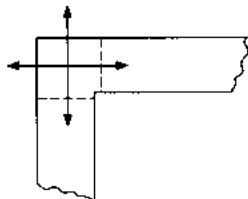

Pull test in Direction of Arrows. Pull rate of 500mm/min. (20 in./min.) is generally acceptable.

Figure 23

Pull test for 45° corners. Pull in direction of arrow.

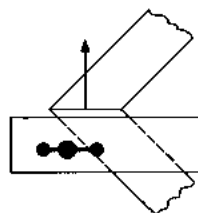
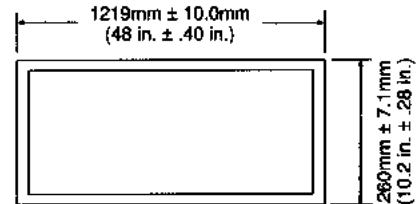

Figure 24



Figure 25

Tolerance on Illustration are Class 2.



In some applications, the splice is required only to position a gasket into place in assembly. This can be accomplished by staples or by using room temperature vulcanizing cements. These are more economical than vulcanized splices.

Tolerances must be allowed in the length of spliced parts. These tolerances must be varied according to length between splices and due to the method of making the splice. The following tables show classes which include both conventional splice requirements and injection splice requirements. Class 1 and 2 are acceptable for conventional splices and Class 2 and 3 are acceptable for injection splices. Discussion between manufacturer and customer should determine the class acceptable and the method of manufacture most acceptable.

Table 18 - Spliced Length Tolerances

RMA Class	1 Precision	2 Commercial	3 Non-Critical
Drawing Designations	S1	S2	S3
Millimeters			
Above - Up to			
0 - 250	±3.2	±6.3	±7.1
250 - 400	4.0	7.1	8.0
400 - 630	5.0	8.0	9.0
630 - 1000	6.3	9.0	10.0
1000 - 1600	8.0	10.0	11.2
1600 - 2500	10.0	11.2	12.3
2500 - over	12.5	12.5	16.0
Inches			
Above - Up to			
0 - 10	±.13	±.25	±.28
10 - 16	.16	.28	.32
16 - 25	.20	.32	.36
25 - 40	.25	.36	.40
40 - 63	.32	.40	.45
63 - 100	.40	.45	.50
100 - over	.50	.50	.53

DESIGN OF EXTRUDED ENDLESS SPLICES

When designing endless splices for extruded profiles, several factors must be considered: durometer of compound, cut length, size of cross section and in the case of tubing, wall thickness.

Mold cavities are normally designed to the nominal dimension. If the extrudate cross section is at the top of the extruded tolerance, mold pressure marks will be visible on the surface and more so with the use of lower durometer compounds. If the extrudate cross section is at the low end of the extruded tolerance, the mold cavity would have to be shimmed in order to attain splicing pressure creating some surface marking. The longer the cut length, the greater the difference in size at each end. (One end may be on high tolerance and the other end on low tolerance.) Generally, this gives the appearance of a step or mismatch. See Figure 26.

Tubing is subject to the same considerations but in addition, thin wall tubing may require internal support in order to achieve sufficient molding pressure. The type of insert used and whether or not it should be removed would have to be resolved between manufacturer and purchaser.

It is to the advantage of both customer and rubber manufacturer to discuss design and application of extruded endless splices. See Figure 27.

Figure 26

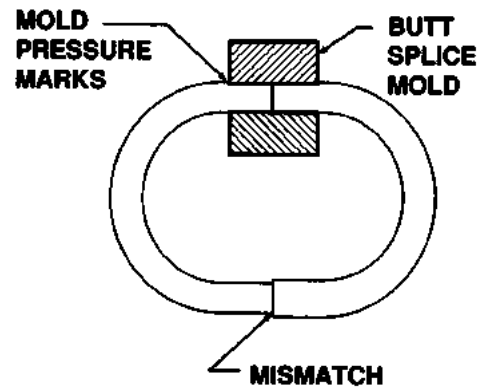
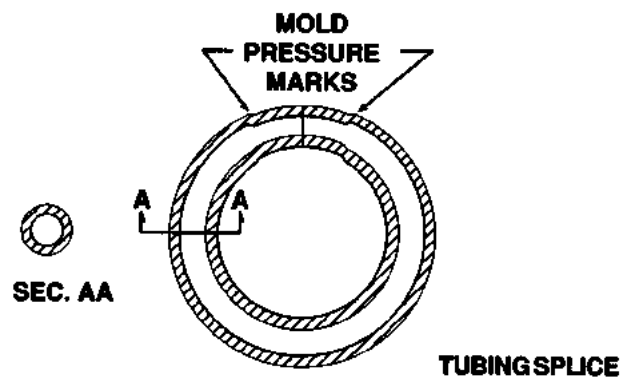

Figure 27



STANDARDS FOR OUTSIDE DIMENSIONS OF SURFACE GROUND EXTRUSIONS

If it becomes necessary to hold the outside diameter of extruded mandrel cured tubing to closer tolerances than normal manufacturing methods will permit, this can be accomplished by surface grinding the part if the part has an inside diameter of 5.0mm (0.20 in.) or more.

A drawing of this type of part should specify inside diameter or outside diameter, wall thickness, and outside finish. If ground finish is desired, it should be classified as one of the following : rough, smooth, or fine.

Table 19 - Tolerances on Outside Dimensions of Surface-Ground Extrusions

RMA Class		1 (Precision)	2 (Commercial)
Drawing Designation		EG1	EG2
Dimensions (In Millimeters)			
Above	Up to		
5	10	±0.15	±0.25
10	16	0.20	0.35
16	25	0.20	0.40
25	40	0.25	0.50
40	63	0.35	0.70
63	100	0.40	0.80
100	160	0.50	1.00
160		0.3%	0.6%
Dimensions (In Inches)			
Above	Up to		
0.20	0.40	±0.006	±0.010
0.40	0.63	0.008	0.014
0.63	1.00	0.008	0.016
1.00	1.60	0.010	0.020
1.60	2.50	0.014	0.028
2.50	4.00	0.016	0.032
4.00	6.30	0.020	0.040
6.30		0.3%	0.6%

STANDARDS FOR INTERNAL DIMENSIONS OF MANDREL-SUPPORTED EXTRUSIONS

When it becomes necessary to hold the tubing round and to close tolerances, a mandrel of the proper size must be inserted in the I.D. of the tubing before vulcanizing. This limits the length of the tubes. Shrinkage usually occurs when the product is removed from the mandrel so that the resulting size of the mandrel-supported dimension is smaller than the mandrel size. The dimension may, however, be larger should the positive tolerance for the mandrel exceed the shrinkage of the extrudate and in this case both positive and negative tolerances will need to be applied.

The designer should indicate what type of surface would be required on the O.D. of the tubing such as ground surface, cloth wrapped surface or as extruded. Any tube that has to have close tolerances on the O.D. generally will have a ground finish. A cloth wrap is used usually to help maintain a round I.D. and O.D. when the stock is soft and may sag in curing. The cloth wrapping of a tube (the tube is placed on a mandrel and wrapped tightly in cloth before vulcanizing and then removed after vulcanizing) leaves the imprint of the cloth weave in the rubber.

If type of surface is not indicated, it would then be assumed that the surface is to be as extruded.

Table 20 - Tolerances on Internal Dimensions of Mandrel-Supported Extrusions

RMA Class	1 (Precision)	2 (Commercial)	3 (Non-Critical)
Drawing Designation	EN1	EN2	EN3
Dimensions (in Millimeters)			
Above 0	±0.20	±0.20	±0.35
Up to 4	0.20	0.25	0.40
6.3	0.25	0.35	0.50
10	0.35	0.40	0.70
16	0.40	0.50	0.80
25	0.50	0.70	1.00
40	0.70	0.80	1.30
63	0.80	1.00	1.60
100	1.00	1.30	2.00
160	0.6%	0.8%	1.2%
Dimensions (in Inches)			
Above 0	±0.008	±0.008	±0.014
Up to 0.16	0.008	0.010	0.016
0.25	0.010	0.014	0.020
0.40	0.014	0.016	0.028
0.63	0.016	0.020	0.032
1.00	0.020	0.028	0.040
1.60	0.028	0.032	0.051
2.50	0.032	0.040	0.063
4.00	0.040	0.051	0.079
6.30	0.6%	0.8%	1.2%

STANDARD FOR CONCENTRICITY OF MANDREL CURED AND GROUND EXTRUDED TUBING

CONCENTRICITY

Concentricity is the relationship of two or more circles or circular surfaces having a common center. It is usually designated as T.I.R. (Total Indicator Reading) and is the total movement of the hand of an indicator set to record the amount that a surface varies from being concentric.

Table 21 - T.I.R. Tolerances

RMA Class	1 (Precision)	2 (Commercial)
Drawing Designation	K1	K2
O.D. (In Millimeters)		
Above 0	0.20	0.40
Up to 13	0.25	0.50
13	0.33	0.75
20	0.47	1.15
32	0.50	1.65
50	0.64	2.30
80		
Over		
O.D. (In Inches)		
Above 0.0	0.008	0.015
Up to 0.5	0.010	0.020
0.5	0.013	0.030
0.8	0.016	0.045
1.25	0.020	0.065
2.00	0.025	0.090
3.15		
Over		

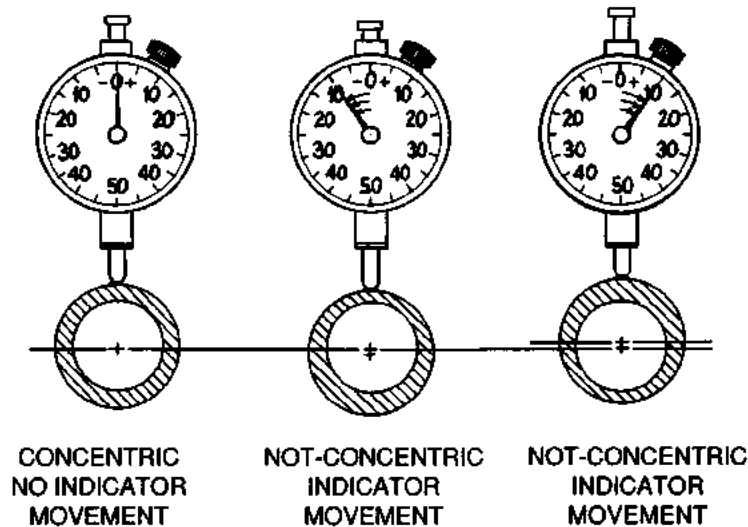

When the above specimen is rotated 360° about the center of the inside circle with a dial indicator in contact with the outside circle, the total sweep of the indicator hand or difference to right and left of zero in above example is referred to as “Total Indicator Reading” or T.I.R. The T.I.R. in this example is 20 units.

OPTIONAL METHOD OF TOLERANCING GROUND EXTRUDED TUBING

Table 22 - Tolerances on Wall Thickness of Surface-Ground Extrusions

RMA Class	1 (Precision)	2 (Commercial)
Drawing Designation	EW1	EW2
Nominal Dimension (In Millimeters)		
Above 0.0	Up to 4.0	± 0.10
4.0	6.3	0.15
6.3	10.0	0.20
10.0	16.0	0.20
16.0	25.0	0.25
Nominal Dimension (In Inches)		
Above 0.0	Up to 0.16	± 0.004
0.16	0.25	0.006
0.25	0.40	0.008
0.40	0.63	0.008
0.63	1.00	0.010

STANDARDS FOR PACKAGING

When a rubber part is packaged, it is for the sole purpose of transportation from the supplier to the user. Packaging usually causes some distortion of the rubber part which, if used in a reasonable length of time, does not permanently affect the part. However, when rubber parts are held in a distorted position for a prolonged period of time, permanent set may cause permanent distortion and result in unusable parts. Any product on which distortion may make the part unusable should be specified and packaged by such methods as will prevent distortion. However, such methods are expensive and should not be specified unless absolutely necessary. With extrusions in long lengths, where it is impractical to ship in straight lengths and coiling in boxes or cartons causes distortion of the product, the product should be removed from the container when received and stored in straight lengths on shelves to preserve usability. Packaging is a complex area and should be given serious consideration. The table at right is to be considered only as a guide. Special packaging problems should be considered between purchaser and supplier.

Table 23 - Extrusion Packaging

RMA Class	Drawing Designation	
1	P1	This class of product will be packaged to eliminate all possible distortion during transportation and storage. This may require special boxes, cartons, forms, cores, inner liners, or other special methods.
2	P2	This class of product will be packaged in corrugated containers or boxes. The quantity of the product packaged per container will be held to an amount which will not crush the lower layers from its own weight, but no forms, cores, inner liners, etc. are necessary.
3	P3	This class of product will be packaged in corrugated paper containers, boxes, crates, burlap bags or bundles, or on skids and pallets. This is the most economical method of packaging but may also produce the greatest distortion in the product.

PURPOSE AND SCOPE

The purpose of this section is to provide the design engineer with sufficient information concerning the lathe cut manufacturing process that will permit him to select the design parameters for lathe cut products which will meet his needs. In addition, this section will outline the methods of specifying a lathe cut product and the tolerance capability that is available through current manufacturing processes.

What is a Lathe Cut?

A lathe cut product is manufactured from a cylindrical tube of rubber by inserting a mandrel into the cylindrical tube and cutting the finished dimensions with a knife while the mandrel is being turned at high speed in a lathe type machine.

Method of Manufacture

The cylindrical tube from which lathe cut products are ~~cut~~ made may be produced by several manufacturing processes depending on design parameters such as size, quantity required, tolerances, and material. The most common manufacturing processes used to produce this tube are:

- a. Injection or compression molding - Since the tube is formed by the molding process, the inside diameter and wall thickness (or outside diameter) are determined by the mold dimensions. Depending on the mold construction, there may be a parting line on the part outside diameter.
- b. Extrusion with continuous vulcanization - Usually suitable for higher volume products. The inside diameter and wall thickness (or outside diameter) should be at finished dimensions after the vulcanization process.

- c. Extrusion with steam cure vulcanization - The extruded tube is loaded onto a curing mandrel and placed in an open steam autoclave. This process may require the tube to be wrapped tight with a fabric material prior to vulcanization to keep the inside diameter in contact with the mandrel. The vulcanization process and mandrel size determines the finished inside diameter dimension. Once the tube is vulcanized, the outside diameter must be ground to provide the proper wall or outside diameter dimension. This is accomplished by placing a mandrel inside the cylindrical tube and grinding the outside diameter to the specified size.

Uses

Lathe cut products are used in many applications such as: Seals, Drive Belts, Vibration Dampeners, Bumpers, Bushings and Insulators.

Design Configurations

Various cross sections are available for lathe cut parts as shown below. (Consult supplier for design specifications.)

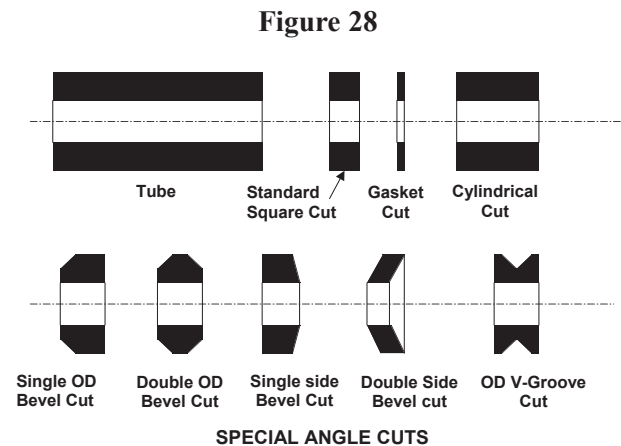

HOW TO SPECIFY A LATHE CUT PRODUCT

Because of the manufacturing methods (as described) required to produce a lathe cut part, it is very important for the design engineer to consider what are the most critical dimensions of the lathe cut part with respect to its application. The conventional lathe cut part with the cut 90° from the axis of the tube can be specified in one of the three following manners:

(1) Normal or most common method--If the inside diameter is the most critical dimension to the function of the part, the lathe cut product will be specified by inside diameter \pm tolerance, the wall thickness \pm tolerance, and cut thickness \pm tolerance. The tolerances will be selected from Table 24.

(2) If the outside diameter is the most critical dimension to the function of the part, the lathe cut product will be dimensioned by outside diameter \pm tolerance as measured over a fixed diameter mandrel that provides a minimum of 3% stretch and the cut thickness \pm tolerance. The outside diameter tolerance for lathe cut parts specified by this method will be selected from Table 25. The cut tolerance will be selected from Table 24.

(3) If the lathe cut product is intended to replace an o-ring, a square cut seal should be specified. The lathe cut product will be specified by inside diameter \pm tolerance, the wall dimension \pm tolerance and the cut dimension \pm tolerance. The nominal wall dimensions and cut dimensions should be equal. Refer to the section "Lathe Cut Products Used as Seals", p. 39.

(4) If concentricity is critical to the function of the part, the tolerance will be selected from Table 26.

Table 24 - Lathe Cut Tolerances - Inside Diameter Tolerance

Drawing Designation		C1	C2	C3
RMA Class		Precision	Commercial	Non-Critical
I.D. (in Millimeters)				
Above	Included			
5.08	17.78	±.13	±.18	±.25
17.78	38.10	.15	.25	.38
38.10	66.04	.25	.38	.64
66.04	127.00	.38	.64	1.27
127.00	177.80	.64	.89	1.78
177.80	228.60	.76	1.14	2.29
228.60	304.80	1.02	1.52	2.54
I.D. (in Inches)				
Above	Included			
.200	.700	±.005	±.007	±.010
.700	1.500	.006	.010	.015
1.500	2.600	.010	.015	.025
2.600	5.000	.015	.025	.050
5.000	7.500	.025	.035	.070
7.500	9.000	.040	.060	.100
9.000	12.000	.050	.075	.125

Note: Tolerances for post cured lathe cut parts from silicone, polyacrylates and other materials usually require greater tolerances on the inside diameter. Consult supplier for tolerance requirements.

Cut Thickness Tolerance

Drawing Designation		C1	C2	C3
RMA Class		Precision	Commercial	Non-Critical
Cut (TK) (in Millimeters)				
Above	Included			
.38	5.08	±.10	±.13	±---
5.08	10.16	.15	.25	.38
10.16	12.70	.18	.38	.76
12.70	15.24	.20	.51	1.14
15.24	17.78	.23	.64	1.52
17.78	25.40	.25	.76	1.91
Cut (TK) (in Inches)				
Above	Included			
.015	.200	±.004	±.005	±---
.200	.400	.006	.010	.015
.400	.500	.007	.015	.030
.500	.600	.008	.020	.045
.600	.700	.009	.025	.060
.700	1.000	.010	.030	.075

Table 24 (Continued) - Wall Thickness Tolerance

Drawing Designation		C1	C2	C3
RMA Class		Precision	Commercial	Non-Critical
Wall (W) (in Millimeters)				
Above	Included			
.76	5.08	±.10	±.18	±---
5.08	7.62	.13	.25	.38
7.62	12.70	.18	.38	.51
Wall (W) (in Inches)				
Above	Included			
.030	.200	±.004	±.007	±---
.200	.300	.005	.010	.015
.300	.500	.007	.015	.020

Figure 29

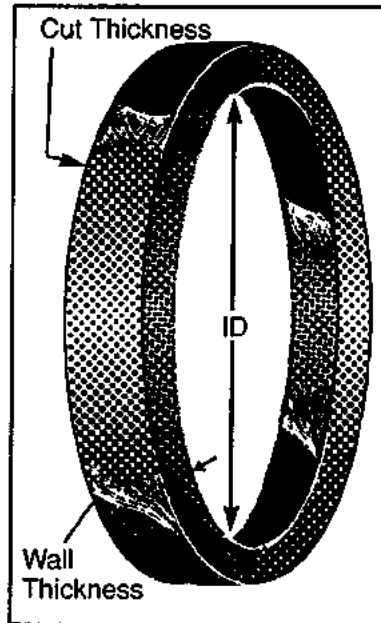

Table 25 - O.D. Tolerance (Measured on Fixed Mandrel)

Drawing Designation	C1	C2	C3
RMA Class	Precision	Commercial	Non-Critical
Wall Thickness (mm)			
Above	Included		
.76	5.08	±.13	±.38
5.08	7.62	.20	.51
7.62	& over	.25	.64
Wall Thickness (in.)			
Above	Included		
.030	.200	±.005	±.015
.200	.300	.008	.020
.300	& over	.010	.025

Note: This chart is to be used only when outside diameter is the most critical dimension. The specification should be outside diameter ± tolerance from the above chart when measured over a fixed diameter mandrel.

Example for C1
O.D. to measure

101.6 ± .20
(4.000 ± .008)

dia. when measured over an 89.90 diameter mandrel.
(3.5000)

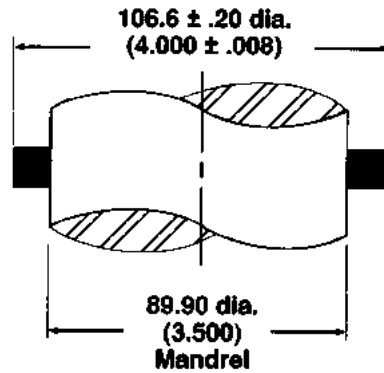

Table 26 - Standards for Total Indicator Reading (T.I.R.) Tolerance (Concentricity*)

Drawing Designation	C1	C2
RMA Class	Precision	Commercial
Inside Diameter (I.D.) (mm)		
Above	Included	
---	12.70	.20
12.70	25.40	.25
25.40	50.80	.33
50.80	& over	.41
Inside Diameter (I.D.) (in.)		
Above	Included	
---	.500	.008
.500	1.000	.010
1.000	2.000	.013
2.000	& over	.016

*Concentricity is the relationship of two or more circles or circular surfaces having a common center. It is usually designated as T.I.R. (total indicator reading) and is the total movement of the hand of an indicator set to record the amount that a surface varies from being concentric. (See example on page 32)

LATHE CUT PRODUCTS USED AS SEALS

When selecting a lathe cut product to fit an existing gland or when designing a seal gland in a new application, the relationship of the lathe cut seal cross section to the gland depth and width is of prime importance. The gland depth governs the amount of squeeze applied to the seal section, while the gland width affects the way the seal fills the gland.

Nearly all applications of lathe cut seals fall into one of the four configurations shown below:

Figure 30 - Four basic applications

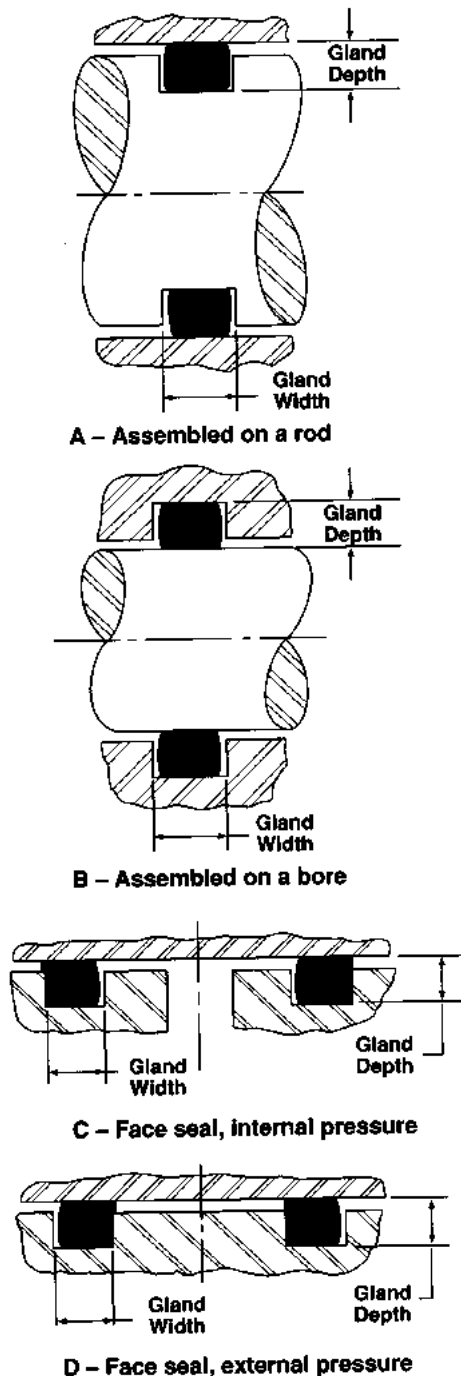

The design chart, Table 27, provides suggested gland depths and widths for each of the five standard seal cross sections. The five standard cross sections are equivalent to the five standard cross sections for O-rings as specified in AS 568 A. Slight variations in existing seal glands from the dimensions shown here are not uncommon. A variation of a few thousandths of an inch in an existing gland does not prevent the selection and application of a standard cross section seal.

Seal squeeze is radial for applications assembled on a rod (A) or in a bore (B). The gland is cut on the outside diameter of a piston or the inside diameter of a bore. Squeeze is obtained when the two mating surfaces are assembled.

For face seal application the gland is cut in the face of a flange or cover. Here consideration should be given to the direction of applied pressure. The seal should be sized to make contact with the low pressure side of the groove as installed. For internal pressure, the seal makes contact with the outside diameter of the gland (C). Conversely, for external pressure applications, the seal is selected to make contact with the inside diameter of the gland (D).

The design chart, Table 27, may be used as a guide in the design of special seals and glands. Particular attention should be given to seal squeeze and gland fill. The chart states the suggested amount of squeeze on the seal cross section necessary to ensure reliable seal performance without overstressing the seal material.

Squeeze is added to the gland depth to determine the seal wall dimensions for radial applications. For face seal application, squeeze is added to the gland depth to determine the seal's cut thickness. (See Figure 31)

Next, consider the percent of fill which is the ratio of the cross sectional area of the seal to the cross sectional area of the gland. In most applications, the designed percent of fill is 80%. This provides ample space for the seal under applied squeeze and allows space for seal swell due to fluid and temperature effects. High pressure applications above 1500 psi, however, may require a greater percent of fill.

Starting with the one seal cross sectional dimension determined by squeeze, the other seal dimension can be determined to arrive at the desired percent of gland fill.

Inside diameter of the seal is determined by the diameter of the gland. For applications where the seal is assembled on a rod or as an external face seal, the inside diameter should make contact with the groove. When assembled in a bore or as an internal face seal, the outside diameter of the seal should make contact with the groove. In both cases, this is prior to assembly.

Table 27 - Design Chart

AS 568 A Dash No.	Nom. Cross Section	Actual Cross Section W x TK	Gland Depth	Gland Width	Inside Radius Max.	Clearance Gap Max.	Squeeze		
							Min.	Mean	Max.
Dimensions in mm			+00 -05	+13 -13					
000 - 050	1.59	1.68 x 1.68	1.44	2.51	.38	.05	.13	.25	.38
106 - 178	2.38	2.51 x 2.51	2.29	3.71	.38	.06	.13	.25	.38
201 - 284	3.18	3.40 x 3.40	3.11	4.90	.64	.08	.19	.32	.44
309 - 387	4.76	5.16 x 5.16	4.75	7.19	.76	.09	.28	.43	.58
425 - 465	6.35	6.73 x 6.73	6.10	9.65	.76	.13	.51	.66	.08
Dimensions in in.			+000 -002	+005 -005					
000 - 050	1/16"	.066 x .066	.057	.099	.015	.002	.005	.010	.015
106 - 170	3/32"	.099 x .099	.090	.146	.015	.0025	.005	.010	.015
201 - 284	1/8"	.134 x .134	.1225	.193	.025	.003	.0075	.0125	.0175
309 - 387	3/16"	.203 x .203	.187	.286	.030	.0035	.011	.017	.023
425 - 465	1/4"	.265 x .265	.240	.380	.030	.005	.020	.026	.032

Figure 31

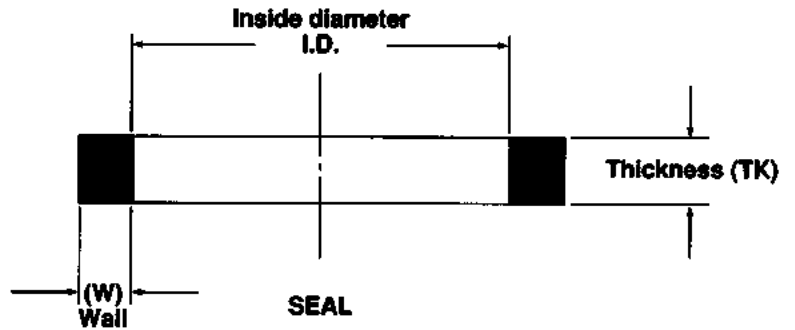
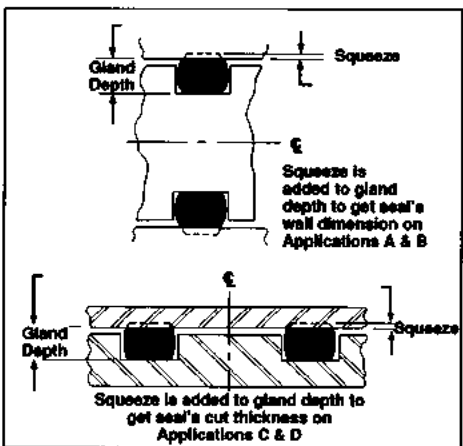
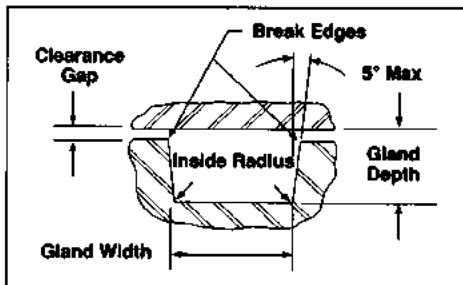

SPONGE AND EXPANDED * SHEET * MOLDED AND EXTRUDED**PURPOSE AND SCOPE**

The purpose of this chapter is to acquaint the design engineer with the fundamentals of cellular rubber quality and dimensional specifications.

Every effort has been made to place at the disposal of the design engineer and purchasing agent sufficient data to reconcile the requirements of the designers with the abilities of the manufacturers of cellular rubber products.

The sections that follow provide the background which is necessary to design and purchase open cell sponge and closed cell expanded rubber parts. Each section sets forth the commonly accepted specification symbols. By carefully determining the degree of perfection required, the design engineer will be able to specify the desired quality in terms which can be interpreted correctly by his supplier.

Open cell sponge* rubber has interconnecting cells, produced by expansion of gases from chemical reactions. Closed cell expanded* rubber has non-interconnecting cells, produced by the controlled release of inert gases such that the gases are entrapped as a multiplicity of separate bubbles in the rubber matrix. Open cell sponge rubber is manufactured in the form of sheets or as molded products (strips or shapes). Closed cell expanded rubber is manufactured in the form of sheets, molded shapes or extrusions.

The physical requirements and material specifications and designations for sponge and expanded cellular* rubbers can be found in ASTM specification D 1056 or SAE specification J18. For the convenience of all concerned, and to promote nationwide uniformity, it is strongly recommended that these grade designations, requirements and test methods be used wherever possible.

The scope of this section presents to the user the tolerances and standards the rubber manufacturers are normally able to maintain relative to the various areas as outlined in the summary of sections.

* The terms “cellular”, “sponge”, and “expanded” have been used, in past years, with various and sometimes conflicting meanings. The usage herein is in accordance with the generally agreed upon and approved definitions in ASTM specification D 1566, and the glossary found at the close of this handbook. “Cellular rubber” is a generic term covering latex foam, urethane foam, sponge rubber, and expanded rubber. Only the sponge and expanded types of cellular rubbers are discussed in this chapter.

SUMMARY OF RMA DRAWING DESIGNATIONS CELLULAR RUBBER PRODUCTS

Drawing Designations

The design engineer should select and designate on the drawing a separate RMA class for dimensional tolerances of the particular product, finish, surface condition and packaging (also splicing and trimming, where applicable). If no class is specified, the rubber supplier will assume that commercial tolerances apply.

Table 28 - Drawing Designation for Dimensional Tolerances

RMA Class	OPEN CELL DIE-CUT Open or closed cell molded		CLOSED CELL SILICONE Molded		CLOSED CELL SILICONE Extruded	CLOSED CELL DIE-CUT Sheet or Strip	
	Thickness Table 30	Length & Width Table 31	Thickness Table 32	Length & Width Table 32	Cross Section Table 33	Thickness Table 34	Length & Width Table 35
A						BTH A	
1	ATH 1	AL 1				BTH 1	BL 1
2	ATH 2	AL 2				BTH 2	BL 2
3	ATH 3	AL 3	STH 3	SL 3	SEC-3	BTH 3	BL 3
4	ATH 4	AL 4					

Drawing Designation for Other Standards

RMA Class	Finish Table 42	Surface Table 43	Splice Table 44	Trim Table 45	Packaging Table 46
A	F A				
1	F 1	R 1	S 1	T 1	P 1
2	F 2	R 2	S 2	T 2	P 2
3	F 3	R 3	S 3	T 3	P 3
4				T 4	P 4
5				T 5	

CLOSED CELL EXTRUDED			CLOSED CELL TUBING		SPONGE/DENSE EXTRUDED
Irregular and Cored Cross Section Table 36	Rectangular and Regular Cross Section Table 37	All Lengths Length Table 38	Inside Diameter Table 39	Wall Thickness Table 40	Length Table 41
BEC 1	BER 1	BEL 1	BET 1	BEW 1	SDL 1
BEC 2	BER 2	BEL 2	BET 2	BEW 2	SDL 2
BEC 3	BER 3	BEL 3	BET 3	BEW 3	SDL 3

EXAMPLES OF USAGE OF RMA DRAWING DESIGNATIONS

Open Cell Sponge Products

Example #1

RMA-ATH 1, AL 2, T 2, F 2, R 2, P 2
Tight Thickness Tolerance, Commercial Length and Width Tolerances; Close Trim, Finish Suitable for Cementing; Good Surface; Small Container Packaging.

Example #2

RMA-ATH 2, AL 1, T 1, F 2, R 2, P 1
Commercial Thickness Tolerance; Tight Length and Width Tolerance (like gasket going into mating stamping); Very Close Die or Hand Trim; Finish Suitable for Cementing; Good Surface; Special Packaging with Core; Dividers, etc.

Example #3

RMA-ATH 2, AL 3, T 4, F 3, R 3, P 3
Commercial Thickness Tolerance; Loose Length and Width Tolerances (like Mold or Die Cut Space Filler Plug); Broad Trim; Finish not Important; Surface not as Important as Function; Commercial Packaging.

Example #4

RMA-ATH 2, AL 2, S 2, T 3, F 2, R 2, P 2
Commercial Thickness Tolerance; Commercial Length and Width Tolerances; Commercial Splice; Moderate Trim; Finish Suitable for Cementing; Good Surface; Small Container Packaging.

Closed-Cell Expanded Products

Example #5

RMA-BTH 2, BL 2, S 1, T 1, F 1, R 1, P 1
Commercial Thickness Tolerance, Commercial Length and Width Tolerances, Very Good Splice (like closed cell corner to weather strip); Very Tight Trim; Very Clean Surface; Smooth Finish; Special Packaging.

Example #6

RMA-BTH 2, BL 1, S 2, T 2, F 2, R 2, P 2
Commercial Thickness Tolerance; Tight Length and Width Tolerances (as to mating part); Normal Splices (may be many as fabricated die-cut part); Commercial Trim; Finish Suitable for Cementing; Good Surface; Small Container Packaging.

TYPES OF PRODUCTS

SPONGE (OPEN CELL)

Sponge rubber is made by incorporating into the compound a gas-producing chemical such as sodium bicarbonate, which expands the mass during the vulcanization process. Sponge rubber is manufactured in sheets, molded strips, and special shapes. Sheets and parts cut from sheets will usually have a surface impression since sheets are usually molded against a fabric surface which allows air to be vented during the expansion of the sponge. Molded strips will have open cells exposed at the ends of the part unless otherwise specified. Die-cut parts will have open cells on all cut edges. On parts where open cell surfaces cannot be tolerated this should be so specified.

Trapped air, which may affect the finish, is a universal problem of sponge manufacturing due to the fact that sponge molds are only partially filled with uncured rubber, allowing for expansion to fill the mold. For this reason long and/or complicated cross sections may require vents or multiple splices to effect low reject percentages. To minimize trapped air, it is common practice to use a considerable amount of a chemically inert dusting agent such as talc, mica, or starch, which is difficult to remove completely from the surface of the finished part, although molded closed cell parts prepared by transfer molding need not have this disadvantage.

In addition to a normal mold skin surface, some parts are manufactured with an applied solid rubber skin or coating to give a more durable, water-resistant surface when exposed to weathering. This is usually applied by calendaring a thin sheet of solid rubber compound (0.005 in. -0.040 in.; 0.12-1.0mm) and applying it to a sheet of sponge compound and placing this in a mold suitably parted to form skin on the exposed surfaces of the part.

Since the solid skin must stretch to cover the surface of the mold during the blowing of the sponge compound, there are practical limitations to designs which can be made by this process, as when skin stretches, the thickness decreases and may ultimately break through. In addition to the above method, an applied skin may be formed by dipping a molded and cured part in latex or cement and depositing a coating on the surface of the part, followed by suitable drying and curing. This coating may be built up to desired thickness by multiple dipping. Limitations on this method are those inherent in most dipping methods such as a tendency to bridge slots or holes, loss of detail of molding, and uneven thickness of skin.

EXPANDED (CLOSED CELL)

Closed cell rubbers are made by incorporating gas forming ingredients in the rubber compound, or by subjecting the compound to high pressure gas such as nitrogen. Expanded rubbers are manufactured in sheet, strip, molded and special shapes by molding or extruding.

Closed cell sheets are generally made rectangular and of sufficient thickness to be split into several layers for die-cutting. From this use is derived, for economic reasons, the term "skin one side or no sides, our option". Closer tolerances can usually be maintained on split sheets (no skin surfaces) than on sheets with a natural skin. Unless otherwise specified, the presence of the skin on the top or bottom surfaces of sheet and strip expanded rubber is optional. Die-cut parts will have exposed cells on all cut edges. On parts where exposed cell surfaces cannot be tolerated (appearance or abrasion, etc.) this should always be so specified.

EXPANDED (CLOSED CELL) - continued

Extruded closed cell rubber is made by extruding the raw compound through a die which determines the shape of the section. The extruded stock is carried from the die by a conveyor system in a continuous process through vulcanizing chambers. As it moves through the vulcanizing chambers the heat causes the blowing agent to decompose to produce an inert gas which expands the extrusion. The gas generation takes place in the middle section of the vulcanizing process and the cure is completed as the extrusion completes its travel through the remaining chambers. On emerging from the vulcanizing chamber the extrusion is cooled to create dimensional stability. Hole punching, coating, dribacking, buffing and cutting are additional operations which can be performed following the cooling. The extrusion can be placed onto reels in continuous lengths or cut to specific lengths depending on the needs of the customer.

Characteristics of Extruded Closed Cell Rubber are:

1. The surface of the extruded section has a natural skin formed during vulcanization.
2. It is possible to produce the part in continuous lengths.
3. A great variety of complex and irregular shapes may be produced.
4. Air chambers or hollowed-out designs may be utilized, giving the advantage of reduction in weight of material. The design engineer, by properly designing the cross-section with maximum air chamber space, can generally achieve considerable advantage in terms of performance and compression deflection.

Molded closed cell parts are manufactured similarly to open cell molded sponge. They require venting of trapped air and possibly the use of inert dusting powder which is difficult to remove completely from the surface of the finished part.

Distinct advantages of closed cell products are their low water absorption characteristics, providing a tight seal and the ability to conform to curves, corners and varying cross-sections without bridging or creasing. This is attributable to the closed cells which do not collapse, losing air as in open cell sponge, and yet deform sufficiently to conform tightly to irregular surfaces. Its thermal value is utilized in insulation applications.

Design of extruded or molded shapes (uncored or cored) radically affects the compression of parts and leads to greater or less apparent compression set values.

CELLULAR SILICONE RUBBER

Cellular silicone rubber in sheet, molded or extruded forms can be made by processes similar to those for other cellular rubbers, or by foaming a liquid silicone polymer. A post-cure period in a hot-air oven is usually used to ensure complete vulcanization. Because dimensions can undergo some change during this postcure, wider dimensional tolerances must be allowed, particularly on molded items. Suggested dimensional tolerances for molded cellular silicone rubbers are given in Table 32, and for extruded cellular sili-

cone rubbers in Table 33. Chemically blown cellular silicone is almost always produced with a closed cell structure. Cellular silicone rubber foamed from a liquid can be partially or completely open cell.

SPONGE-DENSE SEALING PRODUCTS

In recent years manufacturers of cellular sealing products have developed and are supplying a type of seal based on a co-extrusion of dense and sponge rubber. The majority of these types of seals are used in the automotive industry to seal doors, hoods, and trunk lids. The major components of this type of seal are cellular compound, dense compound, and reinforcing woven wire (or stamped steel) embedded in the dense portion. The continuous curing process usually requires two extruders with the utilization of hot air, molten salt or fluidized bed curing mediums.

Sponge-dense sealing products are almost always closed cell. These products have many of the characteristics of expanded (closed cell) rubber mentioned in previous paragraphs. Due to the unique design and manufacturing methods, separate length tolerances have been developed for these products. These standards appear in Table 41.

COMPRESSION SET TEST

A compression set test has been in use for a long period of time on solid rubber and open cell sponge rubber products -- 50% compression of sponge, for 22 hours at 70°C (158°F). The set test is used to determine the quality of those products and their applicability to certain types of usage. Because of this extensive use of the set test on other materials, it is frequently applied to closed cellular materials for the same purposes, namely to determine the quality and applicability of the closed cellular material for general usage or for specific jobs. However, due to the special characteristics of the closed cellular structure, the compression set test has an entirely different effect on closed cellular materials and requires an entirely different interpretation. The differences in application and interpretation of the compression set test on open and closed cellular materials are shown in the comparative tabulation in Table 29.

Table 29 - Compression Set Comparative Table

Open Cells	Closed Cells
1. Air is free to pass through open cells. There is no effect of the 70°C (158°F) test temperature on the air pressure in the cells.	1. Air is not free to pass through the closed cells. The 70°C (158°F) test temperature causes an increase in air pressure in the closed cells.
2. All of the compressing pressure is on the rubber during the test.	2. Part of the compressing pressure is on the rubber, but part of it is on the air in the cells during the test.
3. There is no air diffusion effect through the cell wall structure.	3. During the time that the closed cell structure is under pressure, in the test there is some air diffusion through the thin cell walls. (This is the same diffusion effect that occurs when air pressure decreases in an automobile tire over a period of time, even though there is no specific leak in the tube. This effect is a basic characteristic of the rubber or synthetic polymer. It cannot be changed significantly by the cellular rubber product manufacturer.)
4. The rubber is free to recover immediately after the test. Air can go back into the open cells immediately.	4. The rubber is not free to recover after the test. Air cannot go back into the closed cells immediately.
5. The sample retains the compression set after the test.	5. The sample continues to recover long after the test period is over.
6. The compression set test result indicates the state of cure of the rubber sample. An undercured sample shows a high compression set.	6. The compression set test result does not necessarily indicate the state of cure of the sample. It is more an indication of the amount of air that has diffused from the closed cells and has not yet diffused back. However, if all other variables such as density, thickness, recovery time, etc. are controlled, then compression set is a direct function of cure state.
7. On samples which are otherwise equivalent, the test results are not affected greatly by the thickness of the sample.	7. On samples which are equivalent in other respects, the test results are greatly affected by the thickness of the sample tested. This is because of the diffusion effect as noted above.
8. The compression set test result is not directly affected by the hardness of the open cell sponge.	8. The compression set test result is affected by the hardness of the sample, harder materials showing lower percentages of set. This is because in the harder material the rubber portion supports a relatively higher amount of the total pressure in comparison with the air cells.

It is because of this very great difference in behavior of open cell materials vs. closed cell materials in the compression set tests that ASTM D 1056 and SAE J18 contain a modified set test (22 hours at room temperature, with 24 hour recovery) on these materials. For the same reason, several military specifications on closed cellular materials do not use the standard test as indicated above but have various special test requirements which take into consideration the differences of the properties of the closed cellular materials.

STANDARDS FOR DIMENSIONAL TOLERANCES

Introduction

In this section the reader will find standard tolerances for basic dimensions of sponge and expanded rubber parts. Due to the complexity of design (coring, thick and thin cross-section in each part, etc.) it is recommended that tolerances be established for each part, between the manufacturer and customer, only after studying the clearances and the particular function desired in practical use. It should be noticed that tolerances are plus or minus and are related to the actual or theoretical center of the part. In extruded sections or molded strips, it is a good practice to use 10 times size shadow-graphs with tolerances emanating from a specific centerline. In all discussion of tolerances the high compressibility of sponge and expanded rubber parts, as different from solid molded rubber parts, must be taken into consideration as well as the ease of stretching or crowding into sections where design has called for cellular sponge or expanded parts.

Specific information on factors affecting dimensions and tolerances of sponge and expanded rubber materials is presented in the following paragraphs.

Tolerances are given in Tables 30 through 41.

FACTORS AFFECTING TOLERANCES

Shrinkage

All sponge and expanded rubber have some amount of shrinkage after manufacture. The mold designer and rubber compounder must estimate the amount of shrinkage and incorporate this allowance into the mold cavity size, or extrusion die. However, the shrinkage is also a variable in itself, and is affected by such things as rubber batch variance, state of vulcanization, temperature, pressure, and other factors. The shrinkage of various compounds varies widely. As a result, even though the mold or die is built to anticipate shrinkage, there remains an inherent variability which must be covered by adequate dimensional tolerance. Complex shapes may also cause irregular shrinkage.

Expanded (closed cell) materials are particularly affected by the gas under pressure (when first manufactured) in the individual cells.

Optimum conditions would be where the internal pressure is finally equal to atmosphere pressure. Manufacturers stabilize their products by prolonged room temperature aging or by suitable oven conditioning before cutting to dimensions for shipment or fabricating. Since gas is trapped in each closed cell, due consideration should be given to possible changes in dimension resulting from atmospheric temperature and pressure variations.

Mold and Die Design

Molds and dies can be designed and built to varying degrees of precision.

With any type of mold or die, the builder must have some tolerance, and therefore each cavity will have some variance from the others. The dimensional tolerances on the part must include

allowance for this fact. For molds or dies requiring high precision, the machining and design work must be done accordingly.

High pressure is not required for molded cellular pieces allowing the use of cast aluminum molds. For parts which require close register, greater precision can be obtained by other types of mold construction such as self-registering cavities. Tolerances, and quality of finished article, are adversely affected by designs which have undercuts, abrupt changes in volume of cross-section, feather edges and sharp corners. A realistic consideration of tolerances required on the part will usually be more economical, and will result in a more satisfactory production job.

For extrusion dies the same general factors apply.

Trim and Finish

Many different methods are used to remove flash and otherwise complete the finished part. This section is concerned with the effects of finishing methods on dimensions and tolerances.

The objectives of most trimming and finishing operations are to remove the flash, plugs or other rubber material which are not a part of the finished piece. Often this is possible without effecting the important dimensions, but in other instances some material is removed from the piece itself. It is therefore necessary to give consideration to trimming in setting dimensional tolerances.

In expanded products where hot splicing is necessary, there may be irregularity in finish and tolerances due to the temperature of splicing which causes expansion when heating and later contraction of the gas cells on cooling, and also due to pressure which could cause some changes in dimensions.

Core Dimensions

In molded products, core dimensions are determined by the cores in the mold which in turn form the interior of a hollow article.

A core may be suspended individually in a cavity by bars, or pins, or attached to a core bar or other multiple unit. The nature of the part may prevent rigid suspension, causing the pressure of the stock to deflect the core, such as long tubing.

Parts may be deformed or stretched in removal from some types of cores. Realistic tolerances should be established between purchaser and supplier.

On thicker sections of expanded (closed cell) rubber, hollow extrusions should be considered for better control of compression and less material. Alternately, hollow cores of uniform cross-section can be obtained by extruding expanded, closed cell rubber.

Floating of the I.D. (inside diameter) with subsequent variation in wall thickness may not adversely affect the overall dimensions and functions of the part.

Rubber Insert Dimensions

These are the dimensions from a rubber surface to an insert molded to or in the rubber. The accuracy with which these dimensions can be held depends upon the mold construction, method of locating the insert, and the tolerances of the insert. Dimensional control is difficult when inserts are for an odd shape which causes difficulty in loading the mold. The rubber supplier may wish to make slight revisions on an insert to allow use of locating pins, support pins or other devices to prevent inserts from drifting or "floating". Insert irregularities such as edges at formed radii, irregular edges from dies, or shearing often prevent good fit in the mold. The supplier's mold engineers can offer information and help on these details.

Other

There are other items which affect dimensions. The ease of stretching or compressing cellular rubber parts can readily affect the measurements of length and cross-section which in turn affect the tolerances that may be set.

In die-cutting closed cell parts over 12.5mm (0.5 in.) thick, a dish effect occurs on the edges which may affect close tolerances on width and length. (See Figure 32 on p. 51.)

The method of packaging may affect flatness, diameters and other qualities. No attempt has been made to enumerate all the other factors, merely to call attention to the fact that cellular rubber is a compressible, pliable, semi-plastic material. Therefore, the dimensions may not be as important as with a more rigid material.

ENVIRONMENTAL STORAGE CONDITIONS

Temperature

Rubber, like other materials, changes in dimension with changes in temperature. It has a coefficient of expansion which varies with different formulations. Compared to other materials, the coefficient of expansion of rubber is high. To have agreement in the measurement of products that are critical or precise in dimension, it is necessary to specify a temperature at which the parts are to be measured and the time required to stabilize the part at that temperature.

Humidity

Some rubber materials absorb moisture. Hence, the dimensions are affected by the amount of moisture in the product. For those products which have this property, additional tolerance must be provided in the dimensions. The effect may be minimized by stabilizing the product in an area of controlled humidity and temperature for a period not less than 24 hours.

TOLERANCE TABLES

Table 30 - Thickness

Tolerances on thickness dimensions of open cell sponge, die-cut sheet, or strip; and open or closed cell molded cellular rubber.

RMA Class	1	2	3	4
RMA Drawing Designation	ATH 1	ATH 2	ATH 3	ATH 4
Millimeters	Tolerances			
Above - Included				
0 - 3.15	±0.32	±0.4	±0.5	±0.63
3.15 - 6.3	0.4	0.5	0.63	0.80
6.3 - 12.5	0.5	0.63	0.80	1.00
12.5 - 25.0	0.63	0.80	1.00	1.25
25.0 - 50.0	0.80	1.00	1.25	1.50
50.0 & over mult. by	0.020	0.025	0.030	0.035
Inches	Tolerances			
Above - Included				
0 - .125	±0.012	±.016	±.020	±.025
.125 - .250	.016	.020	.025	.0315
.250 - .500	.020	.025	.0315	.040
.500 - 1.00	.025	.0315	.040	.050
1.00 - 2.00	.0315	.040	.050	.055
2.00 & over mult. by	0.020	0.025	0.030	0.035

Table 31 - Length and Width

Tolerances on length and width dimensions of open cell sponge, die-cut, sheet or strip; and sectional and linear dimensions for open or closed cell molded cellular rubber.

RMA Class		1	2	3	4
RMA Drawing Designation		AL 1	AL 2	AL 3	AL 4
Millimeters		Tolerances			
Above	Included				
0.0	6.3	±0.25	±0.4	±0.63	±1.0
6.3	12.5	0.40	0.63	1.0	1.6
12.5	25.0	0.63	1.0	1.6	2.0
25.0	50.0	1.0	1.6	2.0	2.5
50.0	100.0	1.6	2.0	2.5	3.2
100.0	200.0	2.0	2.5	3.2	4.0
200.0	400.0	2.5	3.2	4.0	5.0
400.0	800.0*	3.2	4.0	5.0	6.2
800.0	1600.0* mult. by	0.004	0.005	0.0063	0.008
1600.0	3200.0* mult. by	0.008	0.01	0.0125	0.020
3200.0 & over	mult. by	0.016	0.02	0.025	0.030
Inches		Tolerances			
Above	Included				
0	.25	±.010	±.016	±.025	±.040
.25	.50	.016	.025	.040	.063
.50	1.00	.025	.040	.063	.080
1.00	2.00	.040	.063	.080	.100
2.00	4.00	.063	.080	.100	.125
4.00	8.00	.080	.100	.125	.160
8.00	16.00	.100	.125	.160	.200
16.00	32.00*	.125	.160	.200	.240
32.00	64.00* mult. by	.004	.005	.0063	.008
64.00	128.00* mult. by	.008	0.010	.0125	.020
128.00* & over	mult. by	0.016	0.020	.025	.030

* Accurate measurement of lengths is difficult because these materials stretch or compress easily. Where close tolerances are required on long lengths, a specific technique of measurement should be agreed upon by purchaser and manufacturer.

Note: Class 1 tolerances are not recommended for the softer grades of material, below 63 kPa. (9 psi) compression-deflection.

Table 32

Tolerances on thickness, length and width dimension of molded closed cell silicone cellular rubber.

RMA Class			3		
RMA Drawing Designation			STH 3 and SL 3		
Millimeters			Tolerance		
Above	-	Included			
0	-	3.15	+0.8	-	.04
3.15	-	6.3	±0.8		
6.3	-	12.5	1.0		
12.5	-	25.0	1.25		
25.0	-	100.0	1.6		
100.0 & over	mult. by		0.03		
Inches			Tolerance		
Above	-	Included			
0	-	.125	+.032	-	.016
.125	-	.250	±.032		
.250	-	.500	±.040		
.500	-	1.000	.050		
1.000	-	4.000	.063		
4.000 & over	mult. by		0.03		

Table 33

Extruded closed cell silicone cellular rubber tolerance on cross-sectional dimensions.

RMA Class			3		
RMA Drawing Designation			SEC-3		
Millimeters			Tolerance		
Above	-	Included			
0	-	6.3	+0.8	-	.04
6.3	-	12.5	+1.25	-	.08
12.5	-	25.0	±1.6		
25.0	-	38.0	±2.5		
38.0	-	50.0	±3.2		
50.0 & over	mult. by		0.05		
Inches			Tolerance		
Above	-	Included			
0	-	.25	+.032	-	.016
.25	-	.50	+.050	-	.032
.50	-	1.00	±.063		
1.00	-	1.50	.100		
1.50	-	2.00	.125		
2.00 & over	mult. by		0.002		

Table 34 - Thickness

Tolerances on thickness dimensions of die-cut sheet or strip expanded, closed cellular rubber.

RMA Class		A	1	2	3
RMA Drawing Designation		BTH A	BTH 1	BTH 2	BTH 3
Millimeters		Tolerance			
Above	Included				
0.00	3.15	±0.40	+0.80 - 0.40	±0.80	±1.0
3.15	6.30	0.63	±0.80	1.0	1.6
6.30	12.50	0.80	1.0	1.6	2.5
12.50	25.00	1.25	1.6	2.5	4.0
25.00 & over mult. by		0.04	0.063	0.10	0.16
Inches		Tolerance			
Above	Included				
0	.125	±.016	+.032 - .016	±.032	±.040
.125	.25	.025	±.032	.040	.063
.25	.50	.032	.040	.063	.100
.5	1.0	.050	.063	.100	.160
1.0 & over mult. by		0.04	0.063	0.10	0.16

Table 35 - Length and Width

Tolerances on length and width dimensions of die-cut sheet or strip, expanded, closed-cellular rubber.

RMA	1	2	3
RMA Drawing Designation	BL 1	BL 2	BL 3
Millimeters	Tolerance		
For thickness up to 6.3mm*			
under 25	±0.63	±0.80	±1.0
25 to 160	0.80	1.0	1.25
over 160 mult. by	0.0063	0.01	0.016
For thickness over 6.3 to 12.5mm*			
under 25	±0.81	±1.0	±1.25
25 to 160	1.0	1.25	1.6
over 160 mult. by	0.0063	0.01	0.016
For thickness over 12.5mm*			
under 25	±1.0	±1.25	±1.6
25 to 160	1.25	1.6	2.0
over 160 mult. by	0.0063	0.01	0.016
Inches	Tolerance		
For thickness up to .25 in.*			
under 1.0	±.025	±.032	±.040
1.0 to 6.3	.032	.040	.050
over 6.3 mult. by	0.0063	0.01	0.016
For thickness over .25 to .50 in.*			
under 1.0	±.032	±.040	±.050
1.0 to 6.3	.040	.050	.063
over 6.3 mult. by	0.0063	0.01	0.016
For thickness over .50 in.*			
under 1.0	±.040	±.050	±.063
1.0 to 6.3	.050	.063	.080
over 6.3 mult. by	0.0063	0.01	0.016

*Separate schedules of length and width tolerances are listed for different thicknesses of these materials because of the “Dish” effect in die-cutting. This is more noticeable as the thickness increases. As shown in the drawing below, the “dish” effect is a concavity of die-cut edges (due to the squeezing of the material by the pressure of the cutting die.)

Figure 32

The width “W” (or length) at the top and bottom surface are slightly greater than the width “W-X” at the center.

Note: Class 1 tolerances should not be applied to the softer grades of material, below 63 kPa (9 psi).

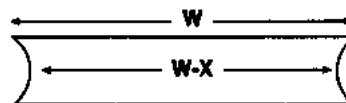

Table 36 - Cross Section

Tolerances on cross-sectional dimensions of irregular and cored shapes of extruded, expanded, closed-cellular rubber. Class 1 tolerances in the table below are recommended only for high volume, tight products for automotive applications.

RMA Class		1*	2	3
RMA Drawing Designation		BEC 1	BEC 2	BEC 3
Millimeters		Tolerance		
Above	Included			
0	6.3	±0.4	±0.5	±0.63
6.3	12.5	0.63	1.0	1.25
12.5	25.0	1.25	2.0	2.5
25.0	40.0	2.0	3.2	4.0
40.0 & over mult. by		0.06	0.08	0.10
RMA Class		1*	2	3
RMA Drawing Designation		BEC 1	BEC 2	BEC 3
Inches		Tolerance		
Above	Included			
0	.25	±.016	±.020	±.025
.25	.50	.025	.040	.050
.50	1.0	.050	.080	.100
1.0	1.6	.080	.125	.160
1.6 & over mult. by		0.060	0.080	0.100

*Class 1 tolerances should not be applied to the softer grades of material -- below 63 kPa (9 psi) compression deflection.

Table 37 - Cross-Sectional Dimension (width, thickness, or diameter)

Tolerances on cross-sectional dimensions of cored, rectangular or other regular shapes of extruded, expanded, closed-cellular rubber.

RMA Class		1	2	3
RMA Drawing Designation		BER 1	BER 2	BER 3
Millimeters		Tolerance		
Above	Included			
3.2	12.5	±0.8	±0.8	±1.0
12.5	25.0	1.25	1.25	2.0
25.0	50.0	1.6	2.0	4.0
50.0	80.0	2.5	3.2	5.0
80.0 & over mult. by		0.06	0.08	0.10
RMA Class		1	2	3
RMA Drawing Designation		BER 1	BER 2	BER 3
Inches		Tolerance		
Above	Included			
.125	.50	±.032	±.032	±.040
.50	1.0	.050	.050	.080
1.0	2.0	.063	.080	.160
2.0	3.15	.100	.125	.200
3.15 & over mult. by		.060	.080	.100

Table 38 - Length

Tolerances on cut lengths of all extruded, expanded, closed-cellular rubber products.

RMA Class		1*	2	3
RMA Drawing Designation		BEL 1	BEL 2	BEL 3
Millimeters		Tolerance		
Above	Included			
0	80	±1.6	±1.6	±3.2
80	160	3.2	3.2	6.3
160	315	6.3	6.3	12.5
315	630**	mult. by .02	12.5	25.0
630	1250**	mult. by .02	25.0	50.0
1250 & over	mult. by	0.02	0.03	0.04
RMA Class		1	2	3
RMA Drawing Designation		BEL 1	BEL 2	BEL 3
Inches		Tolerance		
Above	Included			
0	3.15	±.063	±.063	±.125
3.15	6.3	.125	.125	.250
6.3	12.5	.250	.250	.500
12.5	25**	mult. by .02	.500	1.000
25.0	50**	mult. by .02	1.000	2.000
50.0 & over	mult. by	0.02	0.030	0.040

*Class 1 tolerances should not be applied to the softer grades of material, below 63 kPa (9 psi) compression deflection.

** Accurate measurement of long lengths is difficult because these materials stretch or compress easily. Where close tolerances are required on long lengths, a specific technique of measurement should be agreed upon between purchaser and manufacturer.

Table 39 - Inside Diameter

Tolerances on inside diameter of extruded closed cellular tubings.

RMA Class		1	2	3
RMA Drawing Designation		BET 1	BET 2	BET 3
Millimeters		Tolerance (all plus, no minus)		
Above	Included			
0	12.5	+1.6	+1.6	+3.2
12.5	25.0	2.5	3.2	6.3
25.0	50.0	5.0	6.3	10.0
50.0	100.0	6.3	10.0	12.5
100.0		10.0	12.5	16.0
RMA Class		1	2	3
RMA Drawing Designation		BET 1	BET 2	BET 3
Inches		Tolerance (all plus, no minus)		
Above	Included			
0	0.50	+.063	+.063	+.125
0.50	1.0	.100	.125	.250
1.0	2.0	.200	.250	.400
2.0	4.0	.250	.400	.500
4.0		.400	.500	.630

Table 40 - Wall Thickness

Tolerances on wall thickness of extruded closed cellular tubings.

RMA Class	1	2	3
RMA Drawing Designation	BEW 1	BEW 2	BEW 3
Millimeters	Tolerance		
under 16.0	+1.6	+3.2	+5.0
16.0 and over	3.2	5.0	6.3
RMA Class	1	2	3
RMA Drawing Designation	BEW 1	BEW 2	BEW 3
Inches	Tolerance		
under 0.63	+.063	+.125	+.200
0.63 and over	.125	.200	.250

Table 41

Tolerances on cut lengths of all types of sponge, dense extruded products.

RMA Class	1	2	3
RMA Drawing Designation	SLD 1	SLD 2	SLD 3
Millimeters	Tolerance		
Above	Included		
0	1700	±6.4	±9.5
1700	4500	12.7	19.1
4500	6000	19.1	25.4
6000	TO BE DETERMINED BY MUTUAL AGREEMENT OF CUSTOMER		
50.8			
RMA Class	1	2	3
RMA Drawing Designation	SLD 1	SLD 2	SLD 3
Inches	Tolerance		
Above	Included		
0	66	±0.25	±0.38
66	177	0.50	0.75
177	236	0.750	1.0
236	TO BE DETERMINED BY MUTUAL AGREEMENT OF CUSTOMER		
2.0			

STANDARDS FOR FINISH AND SERVICE CONDITION

SPONGE (OPEN CELL)

In order to better understand the standards set for finish and appearance of sponge products, some of the peculiarities involved in their manufacture affecting these characteristics should be examined.

As mentioned in the discussion, one of the major problems in manufacturing molded sponge items is "trapped air". Unlike solid rubber items, the mold is not loaded to capacity, but only a fraction of the mold is filled with raw compounds, and during the vulcanization process the raw compound is expanded by the action of the blowing agent so that it fills the mold; consequently, when a sponge mold is closed, it includes a volume of air not filled by the stock. Unless this air is dissipated by venting, or by the use of a dust such as mica, "trapped air" leaves depressions in the surface of the cured sponge item caused by the pressure of this air which has been pocketed in various locations in the cavity. It is generally impractical to vent a mold in a sufficient number of locations to bleed out all of this air plus the gases chemically generated in sponge itself. Therefore, it has become common practice in the sponge industry to use a generous quantity of finely ground mica which, due to its plate-like crystalline structure, has the facility to bleed out air more efficiently than any other dusting pigment known.

The mica dust remaining on the surface of the cured sponge item is impossible to remove completely in any cleaning operation that would be economically feasible. In the case of black-colored products, the mica dust tends to make it appear gray because of its own light color. The mica is very insoluble and cannot be washed off completely. All sponge manufacturers have devised cleaning methods to remove the excess dust but still some traces are left on the surface. In most instances this is not a functional defect. If the sponge item is to be adhered to another surface by cementing, an excess amount will interfere with good adhesion. On other surfaces it may act as a lubricant and can be functionally beneficial. If the user of a sponge item insists on absolute freedom from dust, it has the effect of forcing the manufacturer to use little or no dust in the molding, which in turn induces surface defects in the finished product due to "trapped air" such as pitted surfaces and lack of sharp definition, especially on corners and edges.

In the case of automotive weatherstrip and certain gaskets, a thin layer of dense skin is specified over all or part of the surface of the sponge item to give it added resistance to abrasion, ozone and other aging factors. On parts requiring such a skin, it is desirable to design so as to avoid an "under cut" condition, which generally causes the skin to stretch so that it weakens and breaks, exposing the sponge to the surface. If such a condition cannot be avoided in the design of the part, then it is desirable to permit the manufacturer to repair such a spot of broken skin with a "fix" coating to cover and protect the sponge at such points.

Another fairly common surface defect which is usually not a functional defect is the so-called fold or crease in the dense skin on a sponge part. This is generally caused by the raw skin sagging

into the soft sponge due to the heat of vulcanization, and when the expansion takes place and fills the mold cavity, the dust that was on the surface keeps the skin from knitting together thus leaving a fold. This condition can sometimes be corrected by proper compounding, but in certain designs, it becomes difficult, if not impossible, to correct completely.

Another common condition in sponge parts is known as a void. A void, as the name implies, is the lack of substance in a given space. Since sponge is cellular in structure, it is not uncommon for the gases generated, which produce this cellular structure, to accumulate in a small pocket and therefore cause an extra large cell to be formed which, when depressed, feels as though there is nothing there.

EXPANDED (CLOSED CELL)

Sheets of closed cellular rubber are usually split from thicker "buns" of the product. Closer dimensional tolerances can usually be maintained by splitting than by molding directly to the desired thickness. Therefore these sheets, and parts die-cut or fabricated from them, frequently have no skin surfaces.

In general, the finish and surface appearance of extruded and molded closed cell parts are smoother, cleaner, less subject to surface pock marks and voids than open cell products.

Extruded closed cell strips do not have the surface sheen of solid rubber extrusions since the cells do run close to the surface. However, they require little or no dusting powders so are clean and free of trapped air marks and other surface defects associated with open cell sponge.

Molded closed cell parts do require a dusting lubricant but not as much as open-cell molded parts and generally clean better. Also the surface appearance because of the extremely fine closed cells is considerably smoother and has less trapped air marks.

A surface defect which is usually not a functional defect is the so-called fold or crease in the molded natural skin surface of the closed cell molded part. This is apt to occur in sections of considerable variation in cross-sectional areas. As the closed cell material expands, it may fold over on itself and may not completely knit together due to mold lubricating dust on the part. This condition can sometimes be corrected by proper compounding, but in certain designs, it becomes almost impossible to correct completely.

Table 42 - Sponge and Expanded Rubber Finish

RMA Class	Drawing Designation	
A	FA	All surfaces to be washed and totally free of dust and lubricants.
1	F1	All surfaces to be cleaned and free of loose dusting agents and mold lubricants, such as mica, talc, starch, etc.
2	F2	Cementing surfaces shall be cleaned and free of loose dusting agents and mold lubricants. Other surfaces shall be free of excessive dusting agents. Cleaning can be by wiping, tumbling, etc. unless washing is specified.
3	F3	Surfaces may have a small amount of loose dusting agents.

Table 43

Sponge and Expanded Rubber Surface Condition

RMA Class	Drawing Designation	
1	R1	Surfaces shall be smooth and free of imperfection.
2	R2	Surfaces shall be free of pits, pock marks, foreign matter.
3	R3	Surfaces may have imperfections which do not affect the functions of the parts.

For a more detailed treatment of this subject, refer to Specification MIL-STD-293 entitled "Visual Inspection Guide for Cellular Rubber Items."

Table 44 - Sponge and Expanded Rubber Splicing

RMA Class	Drawing Designation	
1	S1	Good alignment, and appearance.
2	S2	Good quality for normal commercial application. (a) Slight variations in alignment. (b) Loose cement spew near seam removed. (c) Slight separation not effecting strength of joint permissible. (d) Parting line flash trimmed to within 1.6mm (0.06 in.).
3	S3	Passable quality standards. (a) Slight variations in alignment. (b) Mold imperfections not effecting strength of joint allowed. (c) No removal of excess vulcanizing cement. (d) Slight separation not effecting strength of joint permissible.

The trimming of molded parts may be accomplished by hand, machine, or die. Due to the softness and resilience of expanded rubber, it is difficult to trim very closely without being extremely careful or occasionally cutting into the part. Multiplane parting lines generally necessitate hand trimming while single plane parting allows for more economical machine or die trimming.

Table 45 - Sponge and Expanded Rubber Trimming

RMA Class	Drawing Designation	
1	T.40mm (T.016)	0.4mm (.016 in.) Flash allowable
2	T.80mm (T.032)	0.8mm (.032 in.) Flash allowable
3	T1.6mm (T.063)	1.6mm (.063 in.) Flash allowable
4	T3.20mm (T.125)	3.2mm (.125 in.) Flash allowable
5	T 0	No trim required (tear trim)

STANDARDS FOR PACKAGING

When sponge and expanded rubber parts are packaged, it is for the sole purpose of transportation of the supplier to the consumer. Packaging usually causes some distortion of the sponge and expanded rubber parts which, if used in a reasonable length of time, does not permanently affect the part. However, when sponge and expanded rubber parts are held in a distorted position for a prolonged period of time, permanent set may cause permanent distortion and result in unusable parts. Any product in which distortion may make the part unusable should be specified and packaged by such methods as will prevent distortion. Where it is impractical to ship in long straight lengths of sponge and expanded extrusions and where coiling in boxes or cartons causes distortion of the product, the product should be removed from the container when received and stored in straight lengths on shelves to preserve usability.

Table 46
Packaging of All Sponge and Expanded Products

RMA Class	Drawing Designation	
1	P1	This class of product must be packaged to eliminate all possible distortion during transportation and storage. This may require special boxes, cartons, forms, cores, inner liners, or other treatment.
2	P2	This class of product must be packaged in corrugated containers or boxes. The quantity of the product packaged per container must be held to an amount which will not crush the lower layers from its own weight, but no forms, cores, inner liners, etc. are necessary.
3	P3	This class of product must be packaged in corrugated containers or boxes in lengths, coils or pieces, but to the weight limit of the container without regard to crushing the product by its own weight.
4	P4	This class of product may be packaged in corrugated containers, boxes, crates, burlap bags or bundles, or on skids and pallets. This is the most economical method of packaging but may also produce the greatest distortion in the product.

PURPOSE AND SCOPE

The complex issues surrounding the development, manufacture/processing, or service of any product for today's market require an effective quality system to identify, document, coordinate and control all key activities necessary to support that service or product. Quality starts with marketing, progresses to product design, to materials' suppliers, to the manufacturing process, and to distribution. It encompasses the entire organization from top management to the workforce. Continuous improvement should be an organizational philosophy supported by top management and understood and carried out by all personnel in a company. In order to meet customer expectations at economical product costs, quality cannot be "inspected in". Quality encompasses the overall system and must be designed into the process.

The intent of this chapter is to define the elements that are necessary for a total quality program for manufacturing molded, extruded, lathe cut, sponge and expanded rubber products. Manufacturers should choose those portions of the total quality program that are applicable to their business requirements.

QUALITY SYSTEM CONTROL PROCEDURES

Quality efforts should begin at the very inception of a product, using customer input as a guide. Optimization during product and process design stages can significantly reduce manufacturing variations. Techniques such as Quality Function Deployment (QFD), Design of Experiments, and Failure Mode Effect Analysis (FMEA) should be studied and used as necessary in the designing stage of a product.

The ISO 9000 series of quality standards should be taken into consideration when developing an overall quality management plan.

SUPPLIER RESPONSIBILITIES

Suppliers of materials and services significantly influence every product produced. Rubber manufacturers should have systems that assure effective selection, monitoring and development of suppliers.

These should include:

- Evidence of supplier capability to meet key requirements.
- Supplier system surveys.
- Ongoing supplier performance ratings and improvement plans based on quality, delivery and service.

Rubber manufacturers and suppliers should have a joint strategy to develop a long-term cooperative relationship.

MANUFACTURING CONTROL

New Products Quality Planning

A team approach should be used in developing a Quality Plan in advance of new product manufacturing. This plan is based on the selection of key characteristics governed by: fit, function, form (appearance), processing and assembly. Purchasing, Sales, Quality, Engineering, Manufacturing, and other affected functions should meet, discuss and finalize items such as:

- Process Capabilities
- Tolerances
- Control Plans (Inspection Points)
- Gaging
- SPC Requirements - Key Characteristics
- Capacities
- Personnel Needed
- Equipment Needed

Drawing and Specification Control

A documented system must be maintained to assure that all drawings and specifications are complete and current. The system must address the control of revisions and deviations and the disposition of obsolete drawings and specifications. Written procedures are necessary to provide for the receipt, review, distribution and revision of drawings and specifications.

Purchase Order Information

A system for controlling purchase orders should be established. Before the purchase order is released, the buyer should make sure that all requirements such as applicable drawings, specifications, certifications, and source inspection instructions are with the purchase order. A drawing or specification change after the order is placed requires a purchase order change, including the latest applicable drawings and/or specifications.

Received Material Audit

An effective system for assuring the quality of incoming products and services should be maintained. Incoming materials should meet physical, chemical, visual, functional, and dimensional requirements.

The degree and extent of the received material audit is based upon the proprietary nature of the purchased material and the supplier's quality history. Certificates of test results of key characteristics should be furnished by suppliers.

Received materials are audited to assure conformance to drawings or specifications and to provide process information to the manufacturing areas. Accepted materials should be specifically identified as such.

All nonconforming material should be identified and segregated from the normal flow of accepted materials. A discrepancy report, formatted to require a corrective action response by the supplier, should be issued for all nonconforming materials. The corrective action document is key to prevent problem recurrence.

Adequate records documenting verifications and audits must be maintained. Such records shall be retained for a minimum of two years.

Process Control

Control procedures must be an integral part of the manufacturing process. The manufacturer must systematically apply procedures and controls effectively to maintain required specifications, reduce variation, document inspection, test results, and corrective action. Identification of materials throughout the manufacturing process must be maintained.

The manufacturer, through knowledge of the production process and end use of the product, shall identify key characteristics and maintain their control. Effective statistical process control (SPC) of designated control characteristics is recommended to identify variations due to the process. Appropriate responses to variations will provide for its reduction and continual improvements.

A capability analysis should be conducted for each control characteristic to determine whether the process is capable of satisfying design intent and to verify that the machinery, operation and process outputs fall within specified design limits. This analysis should be performed after production conditions are stabilized and normal for operations. It should be conducted over an extended period of time. Process capability should be reestablished following any process change due to product, material, tooling or environment.

When processes are identified as being unstable, incapable or out of control, immediate corrective action should be taken based on the analysis of statistical evidence. When control of the process has been established, continuous monitoring techniques should be employed to assure process stability.

Process documentation should be retained for a minimum of two years.

Final Audit

Prior to shipment to the customer, statistical samples of each submitted lot of material should be taken to ensure that the material meets the physical, visual, functional, chemical and dimensional requirements. Written instructions should be provided to assure that these requirements are met.

Nonconforming material should be identified and segregated from the normal flow of final product. Conforming material should be identified and released. A periodic audit of product ready for shipment should be performed.

Documentation of audits should be retained for a minimum of two years.

Nonconforming Material Control

A system to control nonconforming material must be established. The system must identify, segregate and provide for disposition of the material. Written instructions should be provided for repair or rework of the material. Corrected material must be appropriately audited. All other nonconforming material should be discarded. In the event that nonconforming material is suspected or determined to have been shipped, the customer must be notified.

Packaging and Shipping

The supplier is responsible for controlling packaging and shipping to ensure customer acceptance. Products should be handled, packaged and stored for their protection. Customer specifications should be reviewed for special requirements concerning marking, packaging, packing and preservation.

Measurement Control

A system for the calibration of test instruments, tools and gages used to control processes or evaluate material conformance should be established. Military specification MIL-STD-45662 provides information on the standards of a calibration program. When jigs or fixtures are used as measurement devices, their accuracy shall be verified at established intervals and identified to the latest applicable engineering change.

A program to determine measurement device capability used to evaluate key characteristics should be established and maintained. Methods to assure the accuracy of results and use of appropriate statistical techniques to assure repeatability, reproducibility and stability must be included in the program. Gage capability records shall be retained with the gage calibration documentation.

Corrective Action

Corrective action should be taken when a nonconforming product or process is discovered internally or discovered by a customer. The steps to corrective action should be: (1) definition of the problem; (2) diagnosis of the root cause; (3) development and application of a remedy; and (4) evaluation of the effectiveness of the remedy. A disciplined problem-solving approach should be used. After corrective action has been implemented, changes should be incorporated into process specifications and procedures.

Documentation of corrective action is important to promote product and process improvement.

Upon detection of the problem, effected materials should be quarantined and evaluated. Until implementation of corrective action, all materials should be inspected to assure conformance to customer requirements.

Internal Quality Audit

An audit program must be established to review all systems of a facility to assure compliance with controls and procedures. Internal audits should be conducted periodically by personnel independent of the element being surveyed. The procedures for an audit must be written, and formal reports of the results issued. Provisions should be made for correction of any deficiencies.

SERVICE

After the successful design, manufacture and delivery of a product, it is necessary to measure customer satisfaction. This can be achieved by gathering and analyzing information on a routine basis and should include:

- Dealing with customer complaints in a timely, courteous manner with prompt disposition and replacement of unacceptable products.
- Routine visits to the customer, other than response to complaints, in order to determine how the product could be improved. This information should be given to the appropriate staff functions who would work with the customer to improve the product.
- Obtaining field performance information from the customer, outside organizations, or internally in order to define ways to improve the product.

In cases where the customer requests certification data for incoming products, an agreement should be reached as to the type and frequency of such data before production begins:

- For product characterization of a given lot, routine test results could accompany each lot.
- When quality data is requested, it is recommended that such data be available on a quarterly basis.

PEOPLE

The quality philosophy considers that the ultimate creators of quality products and services are people. This requires that any individual, department or team have the necessary tools, equipment, expertise, support and training to produce quality work. People must be recognized as the strength, reputation and vitality of a company. There must be the freedom and opportunity for employees at all levels to suggest and participate in improvement programs. The commitment to the quality program is achieved by an ongoing educational process, providing opportunities for use of cognitive and intellectual skills for all employees.