

Lido 14 Class Sloop Measurement Certificate

This certificate becomes valid when: the hull number and boat weight fields are entered, the inspection/measurement check boxes are filled, and the Measurer Certification and Chief Measurer sections below are completed.

The certificate may be amended to reflect changes made to the boat. Amendments may only be made by the measurer of the fleet to which this boat is affiliated or by a Certified Measurer. Amendments shall be entered, dated, and signed in the AMENDMENTS section. If the AMENDMENTS section is full, a new certificate must be completed.

All boats shall comply to the current Bylaws of the Lido 14 Class Association, which include measurements not shown here.

March 20, 2024 Edition by TJ & JAKP

Copyright © 2024 Lido 14 Class Association. Reproductions are not allowed for official use.

HULL SERIAL NUMBER:

Enter the hull serial number (1 to 4 digits) and the 5th thru 12th digits/letters of the Hull ID, if one is present on the transom.

WDSH

DRY BOAT WEIGHT:

The minimum dry boat weight of 310 pounds includes the hull, centerboard, rudder, tiller, tiller extension, mast, boom, lines, rigging, and fastened accessories such as a compass and lifting sling apparatus. Sails and whisker pole are not included.

MEASURER CERTIFICATION

NAME: _____

SIGNATURE: _____

DATE: _____

MEASURER TYPE: Only the measurer of the fleet to which this boat is affiliated, their official proxy, or a Certified Measurer may sign this certificate.

CERTIFIED

FLEET FLEET #: _____

PROXY ON BEHALF OF: _____

CHIEF MEASURER

NAME: _____

SIGNATURE: _____

DATE: _____

ARCHIVED:

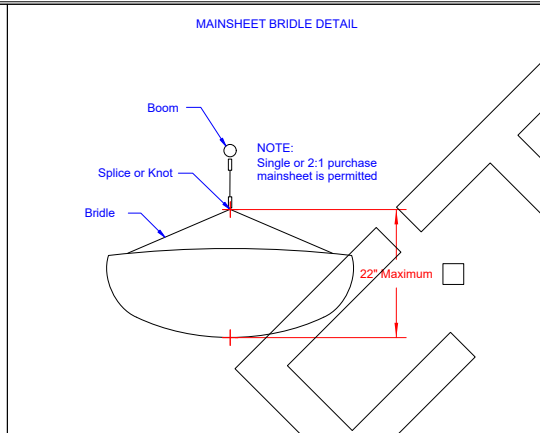
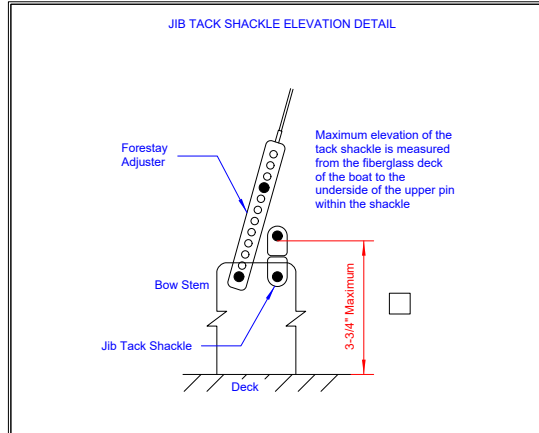
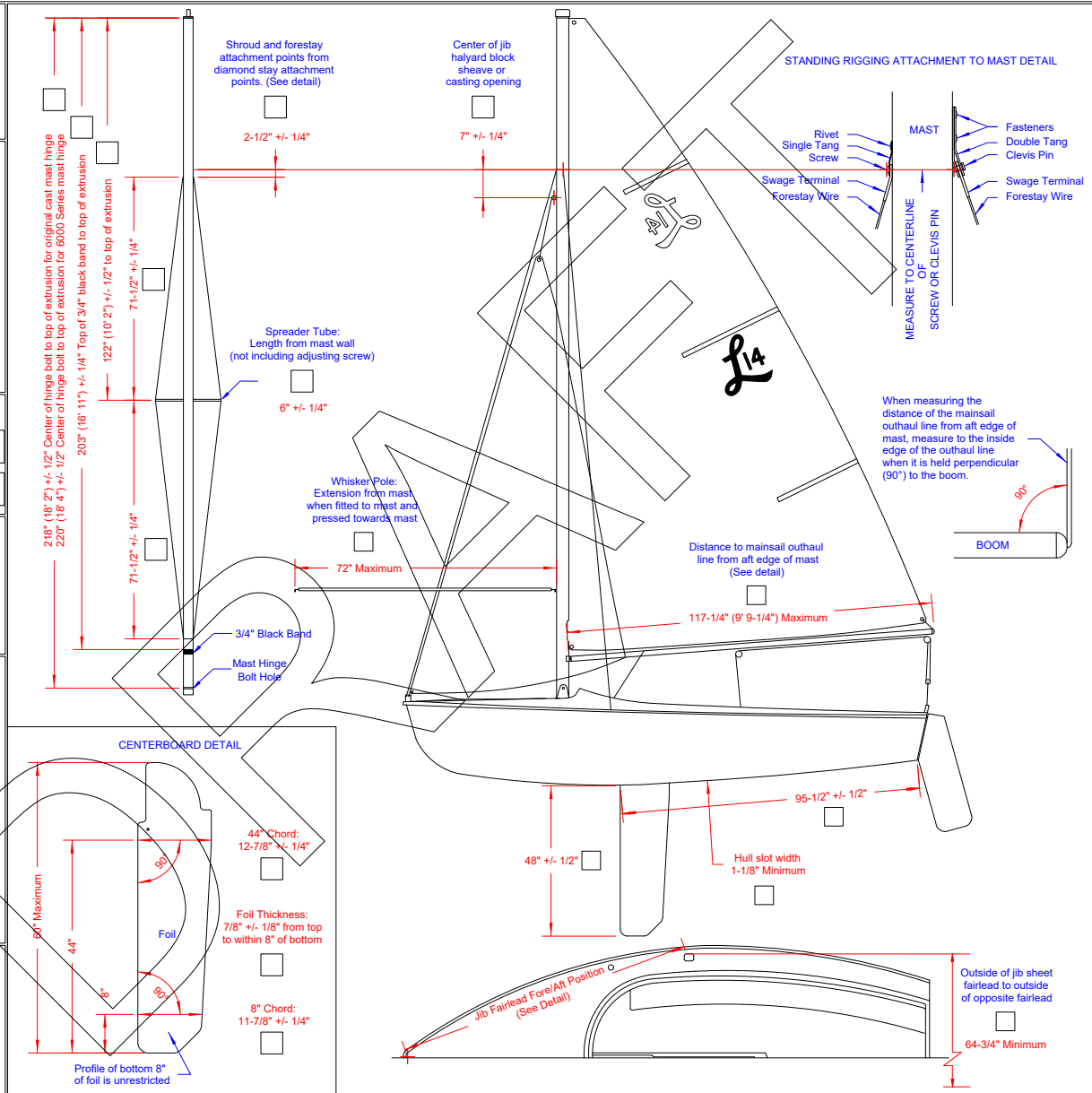

Enter the hull serial number

AMENDMENTS

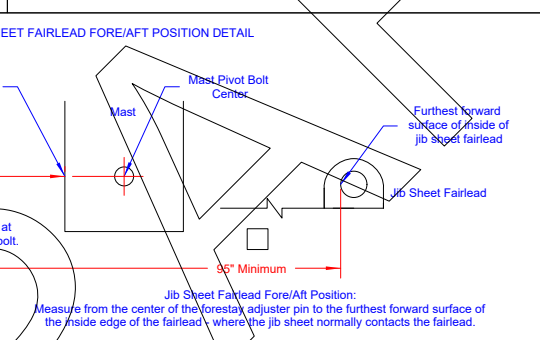
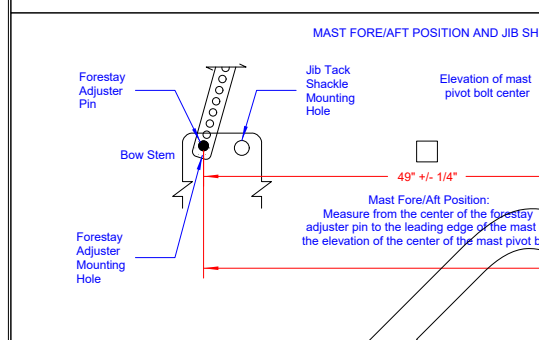

DESIGN AND REPAIR

The design of the boat hull, which includes the materials, shapes, and dimensions of its original construction, have not been altered except as permitted by the current Lido 14 Class Association Bylaws and Approved Changes.

Repairs made to the boat hull are in keeping with the original design of the boat hull (i.e. the materials, shape, and dimensions of the repaired boat are very similar to those of the boat's original construction)

