

Model 110B

- Fire-rated, low profile.
- Use in place of Model 110 when screws & binder posts desired or when door thickness requires.
- Maximum pocket is 1.125" in 1.75" door.

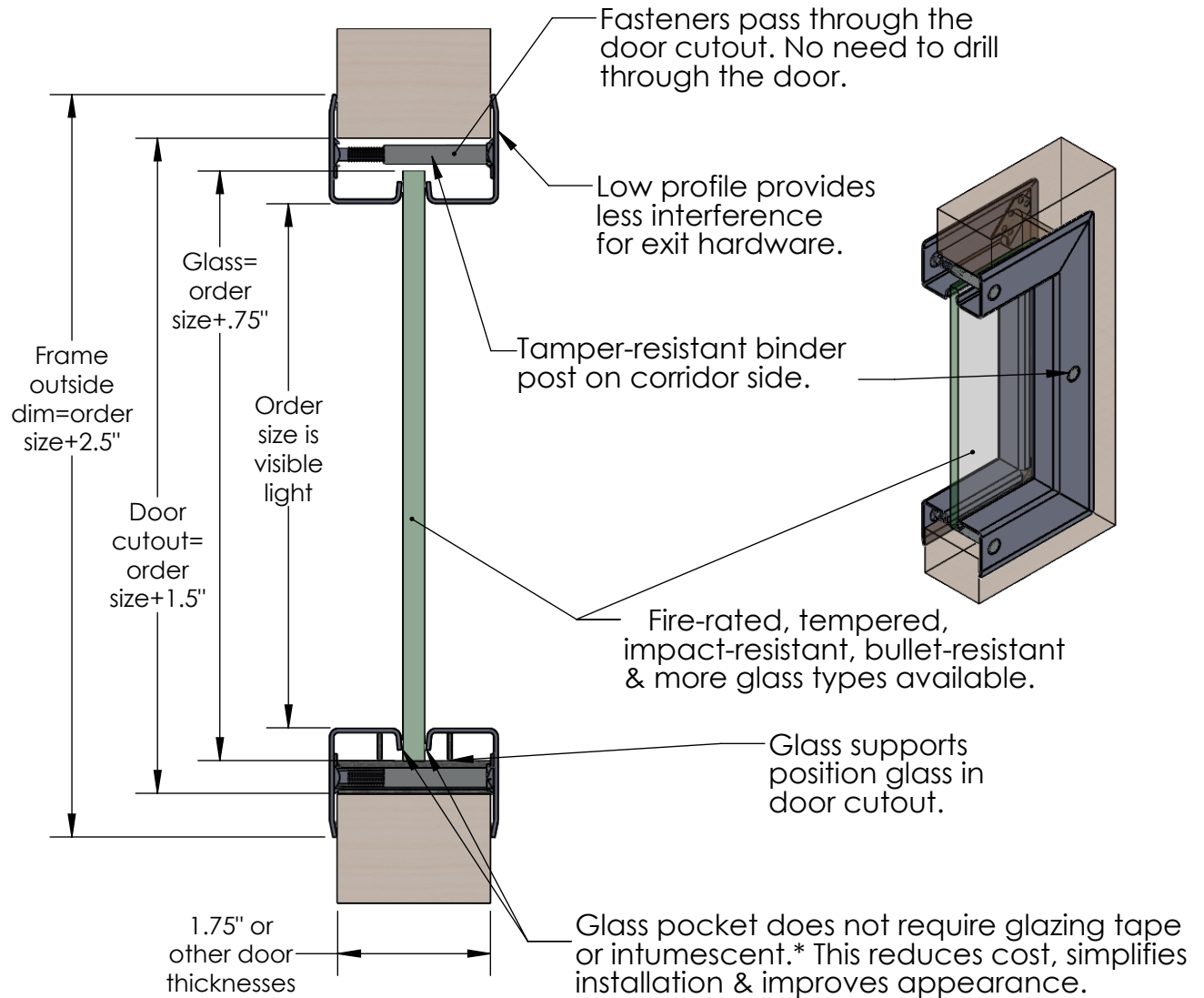

This frame may be installed with most fire-rated glazing material that has approval for conformance to ANSI/UL 10B, ANSI/UL 10C, NFPA 80, NFPA 252, or CAN/ULC S104. Contact AMS for frames intended for use with resistive glass.

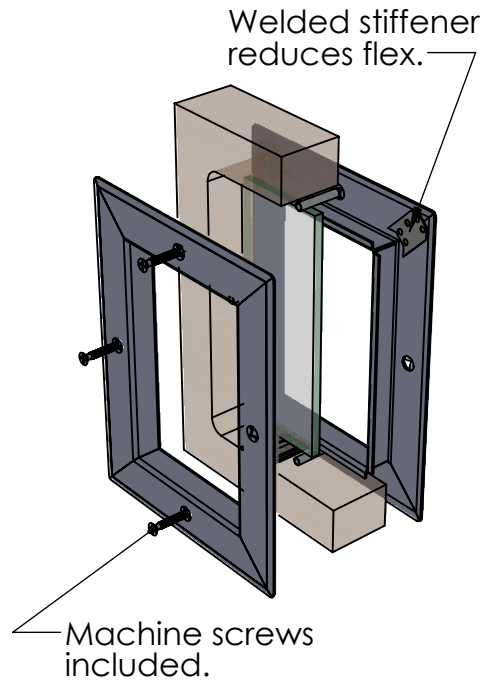

Materials & Finish

- 18 ga mild steel standard.
- Galvanized or stainless steel available.
- Extremely durable powder coating.
- Beige, gray & dark bronze standard.
- RAL & custom colors available.
- Real wood veneer.

* In most fire-rated applications.