

Model 110B-D1

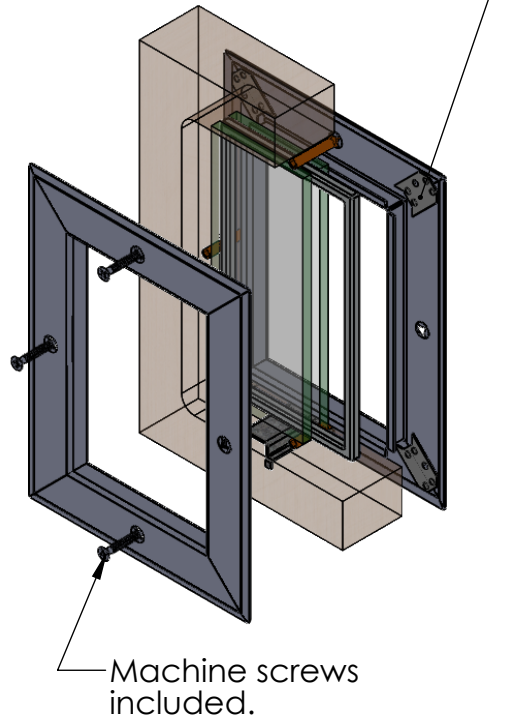

- Low profile, holds 2 pieces of glass, separated by spacer.
- Use in place of Model 110-D1 when screws & binder posts desired.

Welded stiffener reduces flex.



Machine screws included.

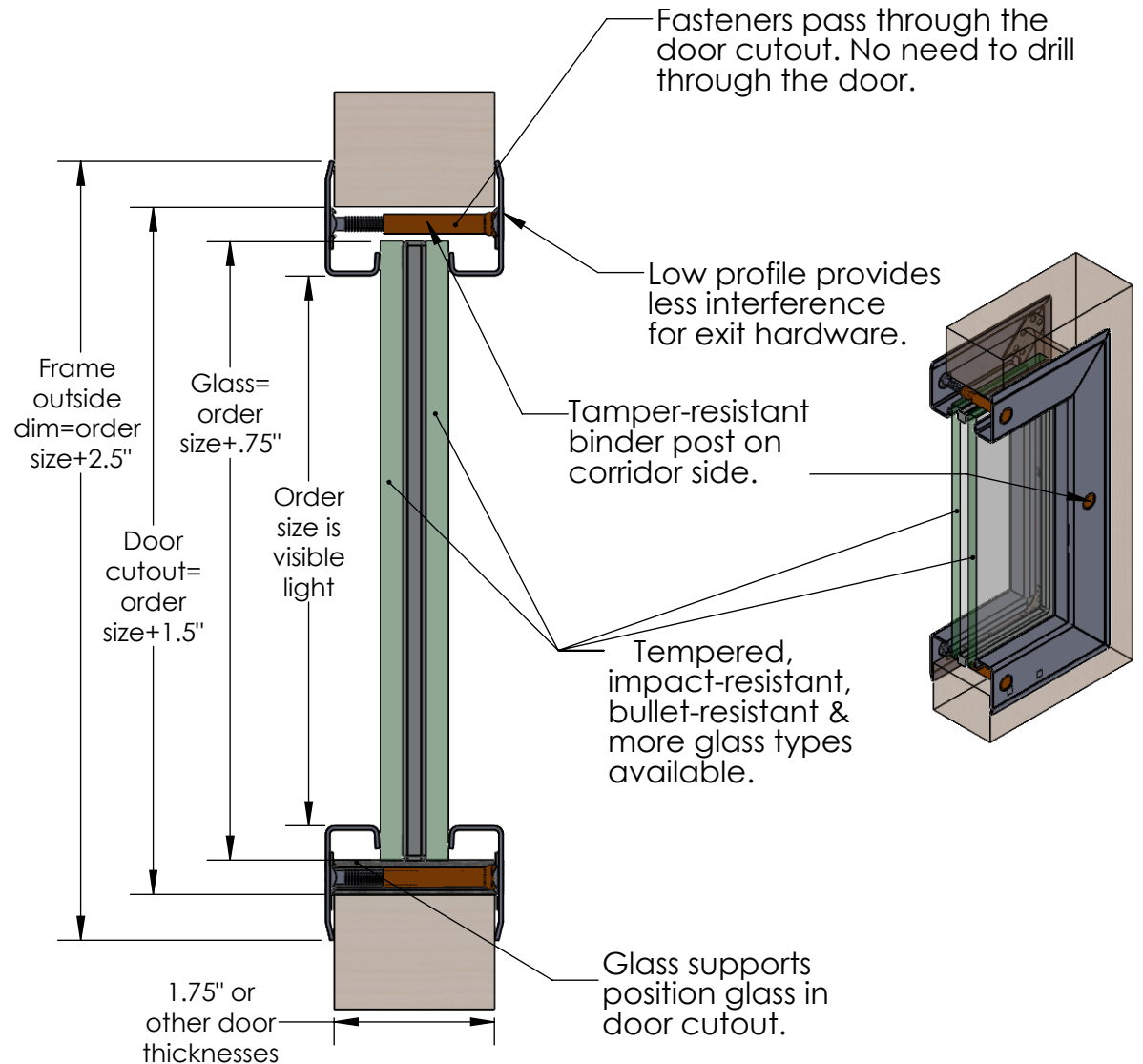

Materials & Finish

- 18 ga mild steel standard.
- Galvanized or stainless steel available.
- Extremely durable powder coating.
- Beige, gray & dark bronze standard.
- RAL & custom colors available.
- Real wood veneer.