

# Model 115-L1

Fire-rated.

Lead-lined to hold fire-rated glass & leaded glass.



This frame may be installed with most fire-rated glazing material that has approval for conformance to ANSI/UL 10B, ANSI/UL 10C, NFPA 80, NFPA 252, or CAN/ULC S104. Contact AMS for frames intended for use with resistive glass.

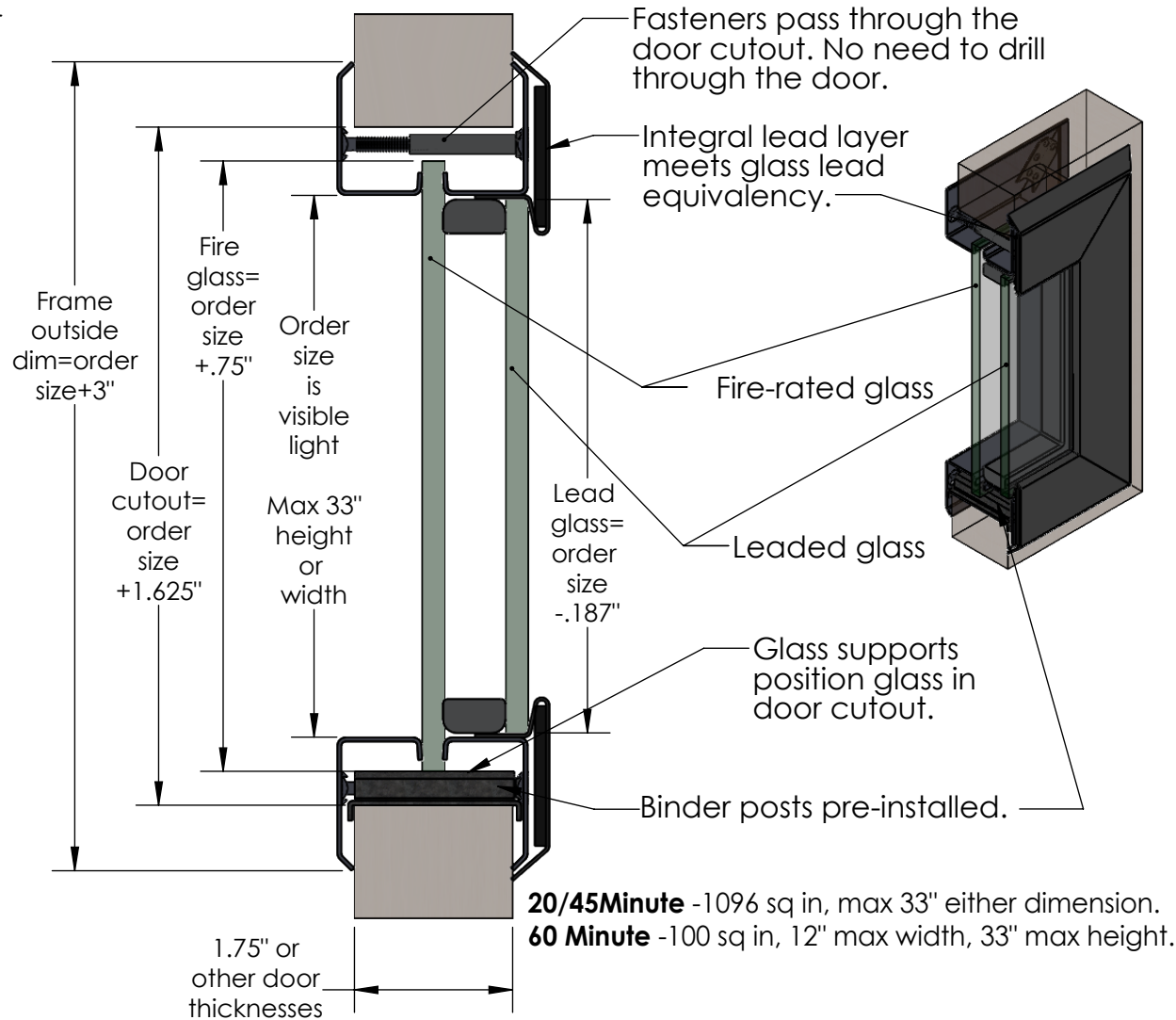
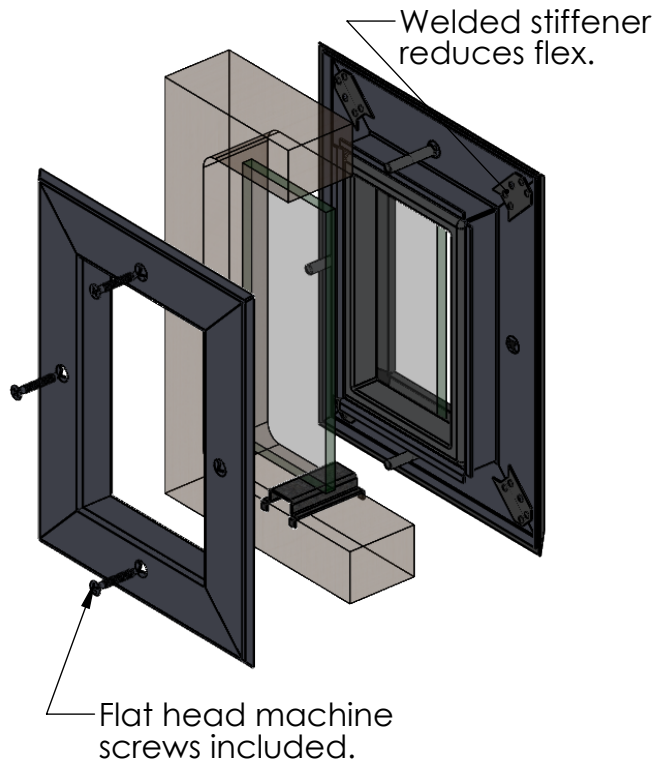

## Materials & Finish

18 ga mild steel standard.  
 Galvanized or stainless steel available.  
 Extremely durable powder coating.  
 Beige, gray & dark bronze standard.  
 RAL & custom colors available.  
 Real wood veneer.

# 115-L1

## Installation Instructions

FOR LEAD X-RAY RADIATION SHIELDING DOORS

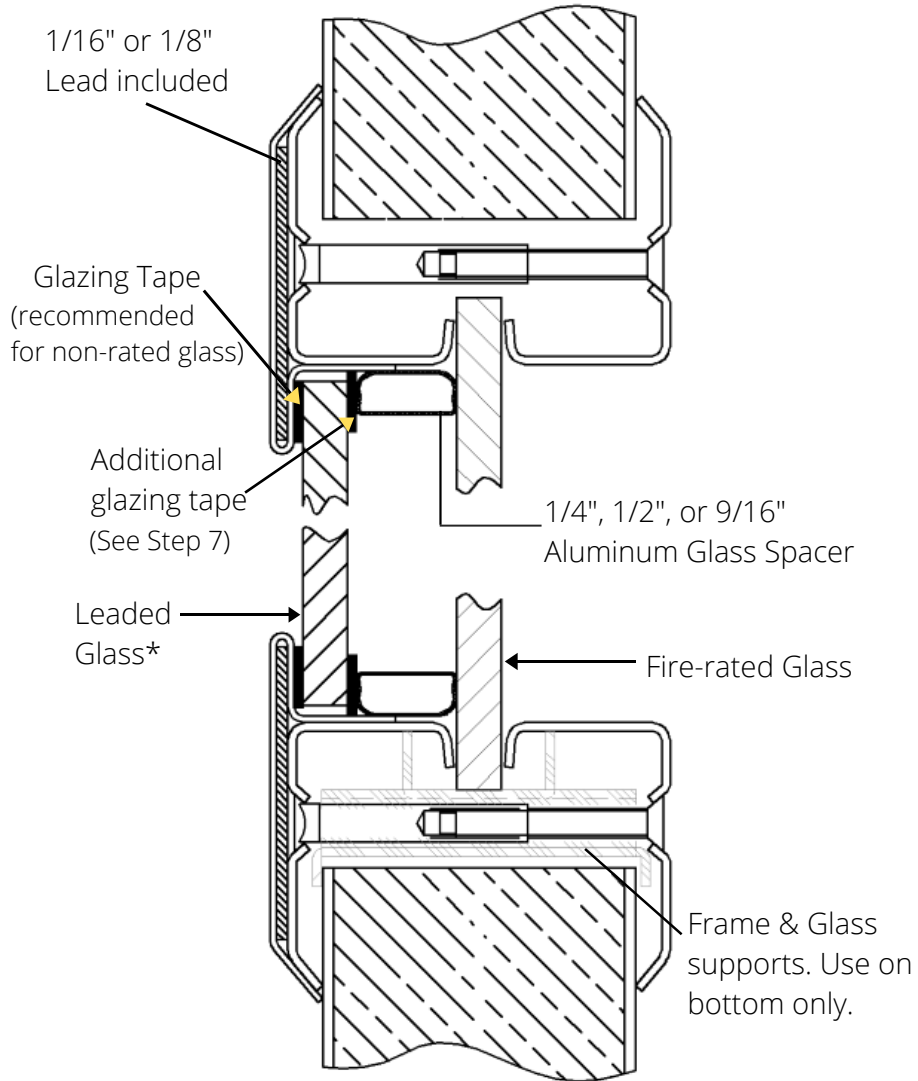

1. Make door cutout 1-5/8" larger than order size. (Visible Glass Dimensions)
2. Place 2 Frame & Glass Supports on bottom of cutout equally spaced from sides.
3. Set leaded half of unit in place with inside lip of frame over tabs of Frame & Glass Supports.
4. Apply glazing tape to frame or glass. Install leaded glass. Install aluminum spacer. Install fire-rated glass (center pane).
5. Set other half of unit in place with inside lip of frame over tabs of Frame & Glass Supports.
6. Install all screws. Snug them evenly after entire unit is fastened. (See  below)
7. Check for rattling or looseness. If glass is loose, apply an additional layer of glazing tape between leaded glass and spacer and repeat steps 4, 5, 6.

Order Size=Inside Dimension of Frame  
Cutout Size=Order Size + 1 5/8"  
Center Glass Size=Order Size + 3/4"  
Lead Glass Size=Order Size - 3/16"



**Do NOT over-tighten screws.  
Over-tightening or uneven tightening  
can cause glass breakage.**

**\*Leaded Glass Installation Tips SEE PAGE 3**

# 115-L1 Installation Instructions



## \*Tips for Installing Leaded Glass

In addition to leaded frames, All Metal Stamping can supply radiation shielding glass as part of an All Metal Stamping leaded door lite kit. Below are suggested guidelines to follow when installing the leaded glass that AMS supplies. For installing glass By Others, please follow the guidelines suggested by that supplier/manufacturer.

1. **Prior to installation**, leaded glass should NOT be exposed to humidity or temperature fluctuations or acid gases. Keep dry.
2. Lead glass is denser than most glass. It can be cut by an experienced glazier, but special safety precautions are required. All Metal Stamping offers the option of getting lead glass already cut-to-size.
3. Precise care must be taken to ensure the radiation protection on the wall side and radiation shielding glass overlap for **total and complete protection** against radiation.
4. There should be NO gaps without protection. Radiation shielding materials must always overlap.
5. If the lead X-ray glass is shipped with a protective film, remove the film only just before installing. Do not use any sharp objects to remove the film.
6. When installing, be sure that sealing agents do not contain any acid or alkaline substances.