

Manual Motor Starters

Ex9S



Hotline 888-949-8337



NOARK



Manual Motor Starters

Ex9S PRODUCT OVERVIEW

Features

Ex9S Manual Motor Starters provide manual isolation, manual motor control, and overcurrent protection. They are electro-mechanical devices combining the functions below in one unit.

- Disconnect for Motor Branch Circuit
- Manual Motor Control (automatic when used with contactor)
- Branch-Circuit Short Circuit Protection (Magnetic Protection)
- Overload Protection (Thermal Protection) - Trip Class 10

The National Electrical Code requires an individual Motor Branch Circuit to be protected by a UL/CSA Listed Fuse, Circuit breaker or Self-Protected Combination Motor Controller.

Available as:

- Up to 80A @600Vac
- UL 60947-4-1 Type E Self Protection-Ex9S32 and Ex9S80
- UL 60947-4-1 Type F Group Motor Protection-Ex9S32
- Built-in fault indication
- Full range of accessories
- Lockable handle



Manual Motor Starters

NOARK Ex9S SERIES

Certifications

Ex9S Manual Motor Starters provide manual isolation, manual motor control, and overcurrent protection. They are electro-mechanical devices combining the functions below in one unit.

- UL listed
- CCC Certified
- NOM Certified
- RoHs Compliant



Standards Compliance

- UL 60947-1; UL 60947-4-1
- IEC/EN 60947-1, IEC/EN 60947-2, IEC/EN 60947-4-1, IEC/EN 60947 -5-1
- GB 14048.1, GB 14048.2, GB 14048.4
- CSA 22.2 NO. 60947-1, CSA 22.2 NO. 60947-4-1



Manual Motor Starters

Ex9S PRODUCT SELECTION

Label

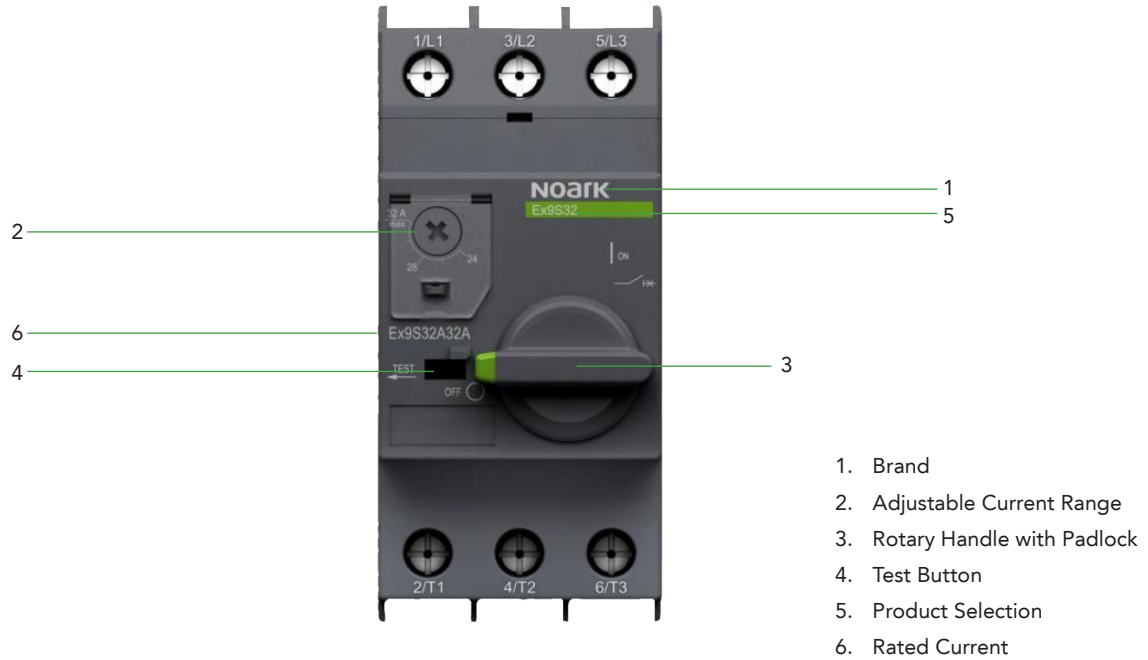

Product Selection Guide

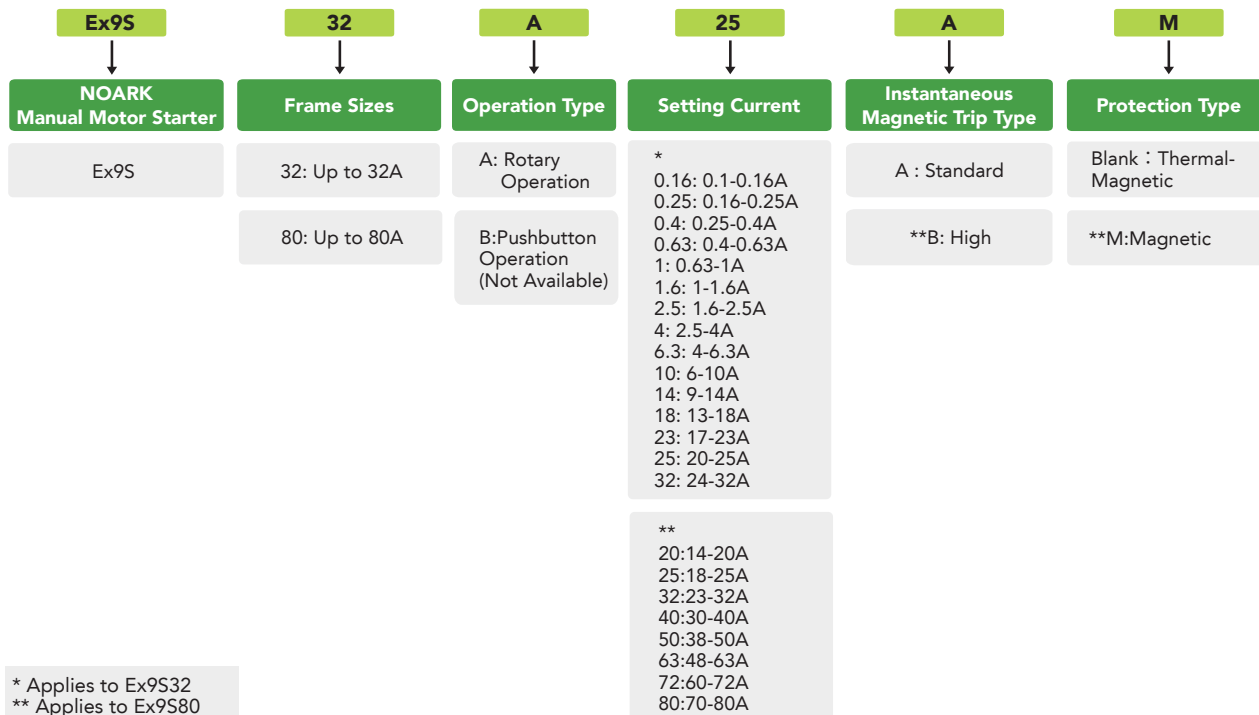



Manual Motor Starters

Ex9S SPECIFICATIONS



Ex9S32

Rated Current Amp (Min-Max)	Thermal Magnetic protection	
	Product	Part Number
0.10~0.16	Ex9S32A0.16A	1600046
0.16~0.25	Ex9S32A0.25A	1600047
0.25~0.40	Ex9S32A0.4A	1600048
0.40~0.63	Ex9S32A0.63A	1600049
0.63~1	Ex9S32A1A	1600050
1~1.6	Ex9S32A1.6A	1600051
1.6~2.5	Ex9S32A2.5A	1600052
2.5~4	Ex9S32A4A	1600053
Rated Current Amp (Min-Max)	Thermal Magnetic protection	
	Product	Part Number
4~6.3	Ex9S32A6.3A	1600054
6~10	Ex9S32A10A	1600055
9~14	Ex9S32A14A	1600056
13~18	Ex9S32A18A	1600057
17~23	Ex9S32A23A	1600058
20~25	Ex9S32A25A	1600059
24~32	Ex9S32A32A	1600060



Ex9S80

Certifications
IEC/EN 60947-4-1

Rated Current Amp (Min-Max)	Thermal Magnetic protection	
	Product	Part Number
14~20	Ex9S80A20A	1600170
18~25	Ex9S80A25A	1600171
23~32	Ex9S80A32A	1600172
30~40	Ex9S80A40A	1600173
38~50	Ex9S80A50A	1600174
48~63	Ex9S80A63A	1600175
60~72	Ex9S80A72A	1600176
70~80	Ex9S80A80A	1600177
Rated Current Amp (Min-Max)	Magnetic protection	
	Product	Part Number
14~20	Ex9S80A20AM	1600185
18~25	Ex9S80A25AM	1600186
23~32	Ex9S80A32AM	1600187
30~40	Ex9S80A40AM	1600188
38~50	Ex9S80A50AM	1600189
48~63	Ex9S80A63AM	1600190
60~72	Ex9S80A72AM	1600191
70~80	Ex9S80A80AM	1600192
Rated Current Amp (Min-Max)	Thermal Magnetic protection	
	Product	Part Number
14~20	Ex9S80A20B	1600178
18~25	Ex9S80A25B	1600179
23~32	Ex9S80A32B	1600180
30~40	Ex9S80A40B	1600181
38~50	Ex9S80A50B	1600182
48~63	Ex9S80A63B	1600183
60~72	Ex9S80A72B	1600184
Rated Current Amp (Min-Max)	Magnetic protection	
	Product	Part Number
14~20	Ex9S80A20BM	1600193
18~25	Ex9S80A25BM	1600194
23~32	Ex9S80A32BM	1600195
30~40	Ex9S80A40BM	1600196
38~50	Ex9S80A50BM	1600197
48~63	Ex9S80A63BM	1600198
60~72	Ex9S80A72BM	1600199



Manual Motor Starters

Ex9S SPECIFICATIONS

Technical Data

Description		Ex9S32	Ex9S80
Rated operational current I _e (A)		32A	80A
Conventional rated thermal current I _{th} (A)		0.16~32A	14-80A
Tripping Class		10	
Rated insulation voltage U _i (Vac)		690/IEC; 600/UL, CSA	
Rated operational voltage U _e (AC)		230/240, 400/415, 460/480, 575/600	
Rated impulse withstand voltage U _{imp} (AC)		6,000V	
Rated Operational Frequency (Hz)		50/60Hz	
Resistance to shock		30 gn -11 ms	
Resistance to vibrations		5gn (5 -150Hz)	
Environmental Temperature	Transportation or Storage	-40°F to 176°F (-40°C to 80°C) ¹	
	Working at	-4°F to 140°F (-20°C to 60°C) ²	
	Testing at	59°F to 77°F (15°C to 25°C)	
	Instantaneous limit	-31°F to 158°F (-35°C to 70°C)	
Altitude ft (m)		Not to exceed 6,562 (2,000)	
Ambient Conditions		At mounting site, relative humidity not exceed 90% at the temperature 104°F (40°C), higher relative humidity is allowable under lower temperature	
Pollution Grade		III	
Mounting Conditions		The inclination between the mounting plane and the vertical plane shall not exceed 30°; The product shall be installed and operated at a place without obvious shock, impact and vibration.	
Service life* (cycles)	Electrical	50,000	50,000 (up to 63A) ;30,000(72A&80A)
	Mechanical	100,000	50,000 (up to 72A) ;30,000(80A)
Duty Class (cycles/hr)		30, max. operating rate	
Degree of Protection		IP 20	

1: 24 hours max. at the ultimated temperature
 2: with temperature reduction factor
 *: close/open operation, and 30 cycles/hr for AC-3 Duty@400/415Vac



Manual Motor Starters

Ex9S SPECIFICATIONS

Overload Protection Properties

	Multiple of Setting Current	Initial Status	Time	Expected Results	Ambient Temperature
1	1.05	Cold Status	$t \geq 2h$	Non-Tripping	68°F to $\pm 35.6^\circ F$ (+20°C to $\pm 2^\circ C$)
2	1.25	Heat Status (right after test 1)	$t < 2h$	Tripping	
3	1.50		$t < 4 \text{ min}$		
4	7.20	Cold Status	$4s < t \leq 10s$		

Phase Failure Protection Properties

	Multiple of Setting Current		Initial Status	Time	Expected Results	Ambient Temperature
	Any 2 Phase	The Other Phase				
1	1.0	0.9	Cold Status	$t \geq 2h$	Non-Tripping	68°F to $\pm 35.6^\circ F$ (+20°C to $\pm 2^\circ C$)
2	1.15	0	Heat Status (right after test 1)	$t < 2h$	Tripping	

Temperature Compensation Properties

	Multiple of Setting Current	Initial Status	Time	Expected Results	Ambient Temperature
1	1.0	Cold Status	$t \geq 2h$	Non-Tripping	104°F to $\pm 35.6^\circ F$ (+40°C to $\pm 2^\circ C$)
2	1.25	Heat Status (right after test 1)	$t < 2h$	Tripping	
3	1.05	Cold Status	$t \geq 2h$	Non-Tripping	-23°F to $\pm 35.6^\circ F$ (-5°C to $\pm 2^\circ C$)
4	1.3	Heat Status (right after test 1)	$t < 2h$	Tripping	



Manual Motor Starters

Ex9S SPECIFICATIONS

IEC Motor Power

Manual self-protected starter	Overload Trip Range	Standard rated power of three-phase motor (kW) AC-3,50Hz/60Hz			
		230/240Vac	400/415Vac	500Vac	690Vac
Ex9S32A0.16A	0.1 - 0.16A	-	-	0.06	0.06
Ex9S32A0.25A	0.16- 0.25A	-	0.06	0.09	0.12
Ex9S32A0.4A	0.25 - 4A	0.06	0.09	0.12	0.18
Ex9S32A0.63A	0.4 - 0.63A	0.09	0.18	0.18	0.25
Ex9S32A1A	0.63 - 1A	0.18	0.25	0.37	0.55
Ex9S32A1.6A	1 - 1.6A	0.25	0.55	0.75	1.1
Ex9S32A2.5A	1.6 - 2.5A	0.37	0.75	1.1	1.5
Ex9S32A4A	2.5 - 4A	0.75	1.5	2.2	3
Ex9S32A6.3A	4 - 6.3A	1.5	2.2	3	4
Ex9S32A10A	6 - 10A	2.2	4	5.5	7.5
Ex9S32A14A	9 - 14A	3	5.5	7.5	11
Ex9S32A18A	13 - 18A	4	7.5	11	15
Ex9S32A23A	17 - 23A	5.5	11	15	18.5
Ex9S32A25A	20 - 25A	5.5	11	15	22
Ex9S32A32A	24 - 32A	7.5	15	18.5	22
Ex9S80A20A(M)	14- 20A	4	7.5	11	15
Ex9S80A20B(M)	14- 20A	4	7.5	11	15
Ex9S80A25A(M)	18- 25A	5.5	11	15	22
Ex9S80A25B(M)	18- 25A	5.5	11	15	22
Ex9S80A32A(M)	23- 32A	7.5	15	18.5	30
Ex9S80A32B(M)	23- 32A	7.5	15	18.5	30
Ex9S80A40A(M)	30- 40A	11	18.5	22	37
Ex9S80A40B(M)	30- 40A	11	18.5	22	37
Ex9S80A50A(M)	38- 50A	11	22	30	45
Ex9S80A50B(M)	38- 50A	11	22	30	45
Ex9S80A63A(M)	48- 63A	15	30	37	55
Ex9S80A63B(M)	48- 63A	15	30	37	55
Ex9S80A72A(M)	60- 72A	18.5	37	45	65
Ex9S80A72B(M)	60- 72A	18.5	37	45	65
Ex9S80A80A(M)	70- 80A	22	45	50	70



Manual Motor Starters

Ex9S SPECIFICATIONS

IEC Interrupting Capacity

Manual self-protected starter	Overload Trip Range	400 Vac				690 Vac			
		I _{cu} (kA)	I _{cs} (kA)	FUSE		I _{cu} (kA)	I _{cs} (kA)	FUSE	
				aM	gl/gG			aM	gl/gG
Ex9S32A0.16A	0.1 - 0.16A	100	100	-	-	100	100	-	-
Ex9S32A0.25A	0.16 - 0.25A	100	100	-	-	100	100	-	-
Ex9S32A0.4A	0.25 - 4A	100	100	-	-	100	100	-	-
Ex9S32A0.63A	0.4 - 0.63A	100	100	-	-	100	100	-	-
Ex9S32A1A	0.63 - 1A	100	100	-	-	100	100	-	-
Ex9S32A1.6A	1 - 1.6A	100	100	-	-	100	100	-	-
Ex9S32A2.5A	1.6 - 2.5A	100	100	-	-	100	100	-	-
Ex9S32A4A	2.5 - 4A	100	100	-	-	6	4	25	32
Ex9S32A6.3A	4 - 6.3A	100	100	-	-	6	4	32	40
Ex9S32A10A	6 - 10A	100	100	-	-	6	4	32	40
Ex9S32A14A	9 - 14A	100	100	-	-	6	4	40	50
Ex9S32A18A	13 - 18A	50	30	63	80	6	4	40	50
Ex9S32A23A	17 - 23A	50	30	80	100	6	4	40	50
Ex9S32A25A	20 - 25A	50	30	80	100	6	4	40	50
Ex9S32A32A	24 - 32A	50	30	100	125	6	4	50	63
Ex9S80A20A(M)	14 - 20A	100	100	-	-	8	8	50	63
Ex9S80A20B(M)	14 - 20A	100	100	-	-	8	8	50	63
Ex9S80A25A(M)	18 - 25A	100	100	-	-	8	8	50	63
Ex9S80A25B(M)	18 - 25A	100	100	-	-	8	8	50	63
Ex9S80A32A(M)	23 - 32A	100	100	-	-	8	8	50	63
Ex9S80A32B(M)	23 - 32A	100	100	-	-	8	8	50	63
Ex9S80A40A(M)	30 - 40A	50	50	125	160	8	8	63	80
Ex9S80A40B(M)	30 - 40A	50	50	125	160	8	8	63	80
Ex9S80A50A(M)	38 - 50A	50	50	125	160	8	8	63	80
Ex9S80A50B(M)	38 - 50A	50	50	125	160	8	8	63	80
Ex9S80A63A(M)	48 - 63A	50	50	125	160	8	8	80	100
Ex9S80A63B(M)	48 - 63A	50	50	125	160	8	8	80	100
Ex9S80A72A(M)	60 - 72A	50	50	160	200	8	8	100	125
Ex9S80A72B(M)	60 - 72A	50	50	160	200	8	8	100	125
Ex9S80A80A(M)	70 - 80A	50	50	160	200	8	8	100	125



Manual Motor Starters

Ex9S SPECIFICATIONS

UL Motor Power

UL Motor Power (hp)								
Manual self-protected starter	Overload Trip Range	1PH				3PH		
		110-120Vac	220-240Vac	200Vac	208Vac	220-240Vac	460-480Vac	575-600Vac
Ex9S32A0.16A	0.1 - 0.16A	-	-	-	-	-	-	-
Ex9S32A0.25A	0.16- 0.25A	-	-	-	-	-	-	-
Ex9S32A0.4A	0.25 - 4A	-	-	-	-	-	-	-
Ex9S32A0.63A	0.4 - 0.63A	-	-	-	-	-	-	-
Ex9S32A1A	0.63 - 1A	-	-	-	-	-	-	0.5
Ex9S32A1.6A	1 - 1.6A	-	0.1	-	-	-	0.75	0.75
Ex9S32A2.5A	1.6 - 2.5A	-	0.167	0.5	0.5	0.5	1	1.5
Ex9S32A4A	2.5 - 4A	0.125	0.333	0.75	0.75	0.75	2	3
Ex9S32A6.3A	4 - 6.3A	0.25	0.5	1	1	1.5	3	5
Ex9S32A10A	6 - 10A	0.5	1.5	2	2	3	5	7.5
Ex9S32A14A	9 - 14A	0.75	2	3	3	3	10	10
Ex9S32A18A	13 - 18A	1	3	5	5	5	10	15*
Ex9S32A23A	17 - 23A	1.5	3	5	-	7.5	15	20*
Ex9S32A25A	20 - 25A	2	-	-	-	7.5	15	20*
Ex9S32A32A	24 - 32A	2	5	7.5	7.5	10	20	25*
Ex9S80A20A(M)	14- 20A	1	3	5	5	5	10	15
Ex9S80A20B(M)	14- 20A	1	3	5	5	5	10	15
Ex9S80A25A(M)	18- 25A	2	-	-	7.5	7.5	15	20
Ex9S80A25B(M)	18- 25A	2	-	-	7.5	7.5	15	20
Ex9S80A32A(M)	23- 32A	2	5	7.5	7.5	10	20	25
Ex9S80A32B(M)	23- 32A	2	5	7.5	7.5	10	20	25
Ex9S80A40A(M)	30- 40A	3	-	10	10	-	25	30
Ex9S80A40B(M)	30- 40A	3	-	10	10	-	25	30
Ex9S80A50A(M)	38- 50A	-	-	15	15	15	30	40
Ex9S80A50B(M)	38- 50A	-	-	15	15	15	30	40
Ex9S80A63A(M)	48- 63A	5	10	15	20	20	40	50
Ex9S80A63B(M)	48- 63A	5	10	15	20	20	40	50
Ex9S80A72A(M)	60- 72A	-	-	20	-	25	50	60
Ex9S80A72B(M)	60- 72A	-	-	20	-	25	50	60
Ex9S80A80A(M)	70- 80A	-	-	25	25	-	60	75

* Manual Motor Control and Motor Disconnect only, not applied in Combination Motor Control.



Manual Motor Starters

Ex9S SPECIFICATIONS

Short-Circuit Current Rating



Type E: Self-Protected Combination Motor Controller

Manual self-protected starter	Overload Trip Range	Type E		Type E		Type E		Matching accessories
		SCCR (kA)	240Vac	SCCR (kA)	480Y/277Vac	SCCR (kA)	600Y/347Vac	
Ex9S32A0.16A	0.1 - 0.16A		65			10		CCES1, AL5111
Ex9S32A0.25A	0.16 - 0.25A		65			10		
Ex9S32A0.4A	0.25 - 0.4A		65			10		
Ex9S32A0.63A	0.4 - 0.63A		65			10		
Ex9S32A1A	0.63 - 1A		65			10		
Ex9S32A1.6A	1 - 1.6A		65			10		
Ex9S32A2.5A	1.6 - 2.5A		65			10		
Ex9S32A4A	2.5 - 4A		65			10		
Ex9S32A6.3A	4 - 6.3A		65			10		
Ex9S32A10A	6 - 10A		65			10		
Ex9S32A14A	9 - 14A		65			10		
Ex9S32A18A	13 - 18A		42			-		
Ex9S32A23A	17 - 23A		42			-		
Ex9S32A25A	20 - 25A		42			-		
Ex9S32A32A	24 - 32A		42			-		
Ex9S80A20A/B	14 - 20A		42			30		AL5111
Ex9S80A25A/B	18 - 25A		42			30		
Ex9S80A32A/B	23 - 32A		42			30		
Ex9S80A40A/B	30 - 40A		42			18		
Ex9S80A50A/B	38 - 50A		42			18		
Ex9S80A63A/B	48 - 63A		42			10		
Ex9S80A72A/B	60 - 72A		42			10		
Ex9S80A80A	70 - 80A		10			10		



Manual Motor Starters

Ex9S SPECIFICATIONS

UL Motor Power



Type F: Manual Self-Protected Combination Motor Controller

Manual Self-Protected Starter	Associated Cable, AWG 75°C, Cu	Type of Contactor Required	Overload Trip Range(A)	SCCR (kA)			Fault Signaling Accessory	Combination Block	Mounting Bracket
				240V	480Y/ 277V	600Y/ 347V			
Ex9S32A0.16A	14	Ex9CS06/09 Ex9C09	0.1-0.16	65	-	10	AL5111	CC51/CC52	DRA51
Ex9S32A0.25A			0.16-0.25						
Ex9S32A0.4A			0.25-0.4						
Ex9S32A0.63A			0.4-.63						
Ex9S32A1A			0.63-1						
Ex9S32A1.6A			1-1.6						
Ex9S32A2.5A			1.6-2.5						
Ex9S32A4A			2.5-4						
Ex9S32A6.3A			4-6.3						
Ex9S32A10A			Ex9CS12/9C12						
Ex9S32A14A	12	Ex9C18	9-14	-	-	-	CC52	-	
Ex9S32A18A			13-18						
Ex9S32A23A	10	Ex9C25	17-23	42	-	-	CC53	-	
Ex9S32A25A			20-25						
Ex9S32A32A			8						Ex9C38/32



Manual Motor Starters

Ex9S SPECIFICATIONS

Temperature Derating Factor

Device	-20°C ≤ T ≤ 0°C		0°C < T < 30°C		30°C ≤ T ≤ 40°C		40°C < T ≤ 60°C	
	single	group	single	group	single	group	single	group
Ex9S32A0.16A	1.05	1	1	1	1	1	1	0.98
Ex9S32A0.25A	1.05	1	1	1	1	0.99	0.98	0.97
Ex9S32A0.4A	1.05	1	1	1	1	0.96	0.96	0.93
Ex9S32A0.63A	1.05	1	1	1	1	0.97	0.96	0.94
Ex9S32A1A	1.05	1	1	1	1	0.96	0.96	0.91
Ex9S32A1.6A	1.05	1	1	1	1	0.96	0.96	0.93
Ex9S32A2.5A	1.05	1	1	1	1	1	1	0.99
Ex9S32A4A	1.05	1	1	0.98	1	0.98	0.98	0.96
Ex9S32A6.3A	1.05	1	1	0.97	1	0.96	0.96	0.95
Ex9S32A10A	1.05	1	1	0.96	1	0.94	0.94	0.91
Ex9S32A14A	1.05	1	1	0.96	1	0.94	0.94	0.90
Ex9S32A18A	1.05	1	1	0.96	1	0.93	0.92	0.90
Ex9S32A23A	1.05	1	1	0.95	1	0.94	0.93	0.90
Ex9S32A25A	1.05	1	1	0.95	1	0.94	0.93	0.90
Ex9S32A32A	1.05	1	1	0.92	1	0.91	0.91	0.87
Ex9S80A20A/B	1.05	1	1	1	1	0.98	1	0.96
Ex9S80A25A/B	1.05	1	1	1	1	0.98	1	0.96
Ex9S80A32A/B	1.05	1	1	1	1	0.98	1	0.96
Ex9S80A40A/B	1.05	1	1	0.98	1	0.98	1	0.96
Ex9S80A50A/B	1.05	1	1	0.97	1	0.96	0.96	0.93
Ex9S80A63A/B	1.05	1	1	0.95	1	0.93	0.92	0.9
Ex9S80A72A/B	1.05	1	1	0.95	1	0.93	0.93	0.9
Ex9S80A80A	1.05	1	1	0.94	1	0.9	0.9	0.88

* Please refer to derating table for multiple use of electromagnetic product or use single unit above 40°C



Manual Motor Starters

Ex9S SPECIFICATIONS

Manual self-protected starter	Setting Current (A)		Magnetic Trip Rating (A)	
	Minimum	Maximum	A	B
Ex9S32A0.16A	0.1	0.16	2.1	-
Ex9S32A0.25A	0.16	0.25	3.2	-
Ex9S32A0.4A	0.25	4	4.8	-
Ex9S32A0.63A	0.4	0.63	7.2	-
Ex9S32A1A	0.63	1	11	-
Ex9S32A1.6A	1	1.6	20	-
Ex9S32A2.5A	1.6	2.5	30	-
Ex9S32A4A	2.5	4	50	-
Ex9S32A6.3A	4	6.3	72.5	-
Ex9S32A10A	6	10	130	-
Ex9S32A14A	9	14	175	-
Ex9S32A18A	13	18	230	-
Ex9S32A23A	17	23	280	-
Ex9S32A25A	20	25	322	-
Ex9S32A32A	24	32	416	-
Ex9S80A20A(M)	14	20	310	400
Ex9S80A20B(M)	14	20	310	400
Ex9S80A25A(M)	18	25	375	500
Ex9S80A25B(M)	18	25	375	500
Ex9S80A32A(M)	23	32	445	680
Ex9S80A32B(M)	23	32	445	680
Ex9S80A40A(M)	30	40	560	800
Ex9S80A40B(M)	30	40	560	800
Ex9S80A50A(M)	38	50	700	960
Ex9S80A50B(M)	38	50	700	960
Ex9S80A63A(M)	48	63	950	1150
Ex9S80A63B(M)	48	63	950	1150
Ex9S80A72A(M)	60	72	1000	1150
Ex9S80A72B(M)	60	72	1000	1150
Ex9S80A80A(M)	70	80	1150	-

Ex9S32 Trip Curve

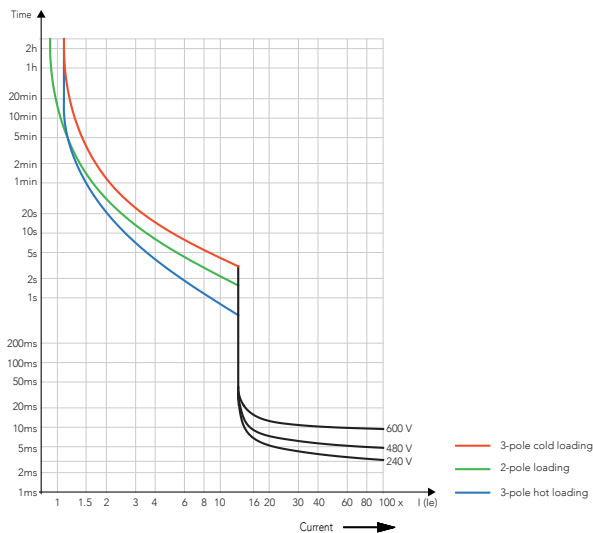

Ex9S80 Trip Curve

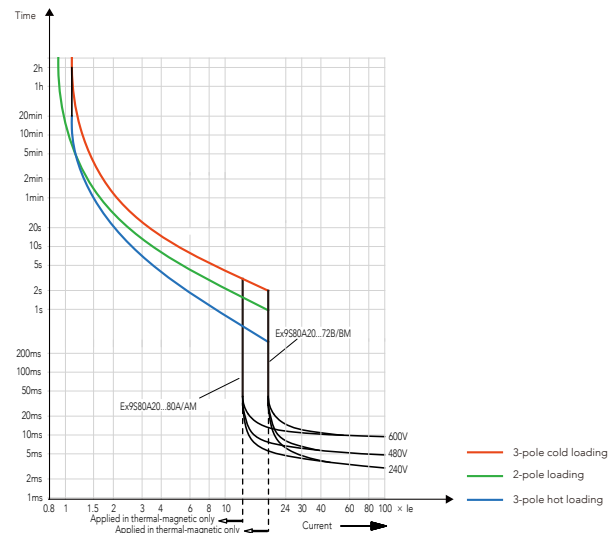



Manual Motor Starters

Ex9S32 DIMENSIONS

Ex9S32
Unit: in. [mm]

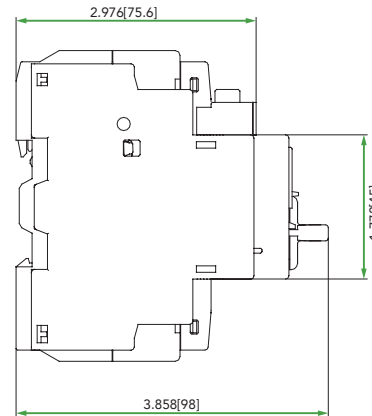
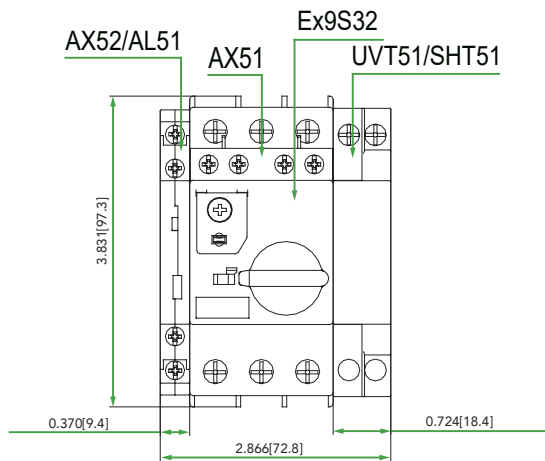
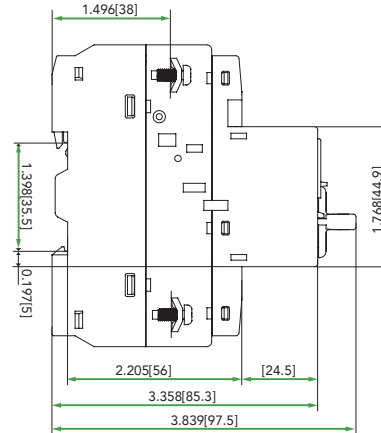
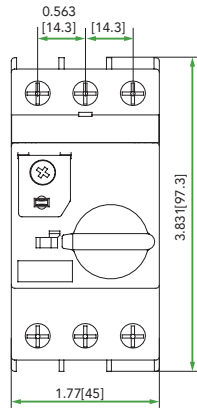

Ex9S32 + CCE51
Unit: in. [mm]

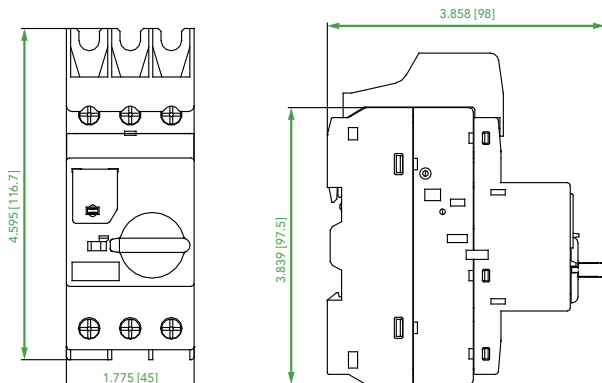

CCE51
Unit: in. [mm]

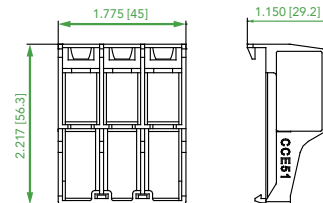



Manual Motor Starters

EX9S80 DIMENSIONS

Ex9S80

Unit: in [mm]

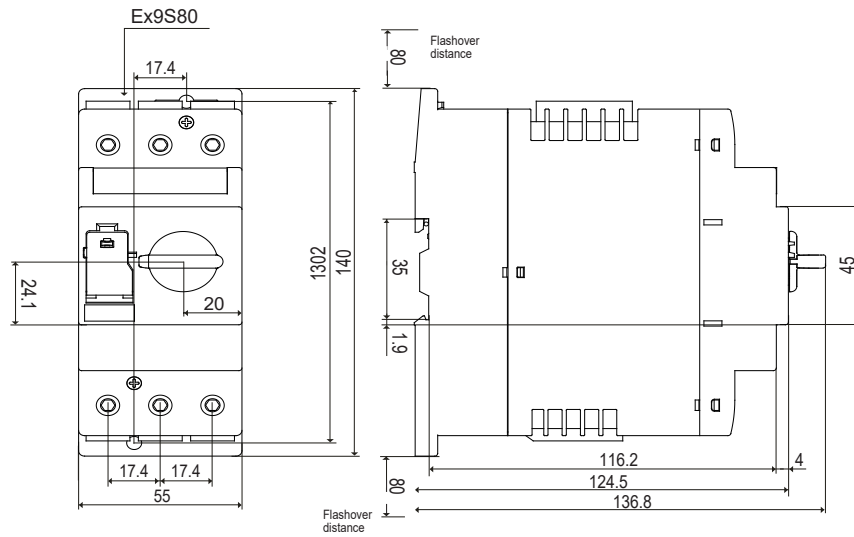

Ex9S80+Accessory

Unit: in [mm]

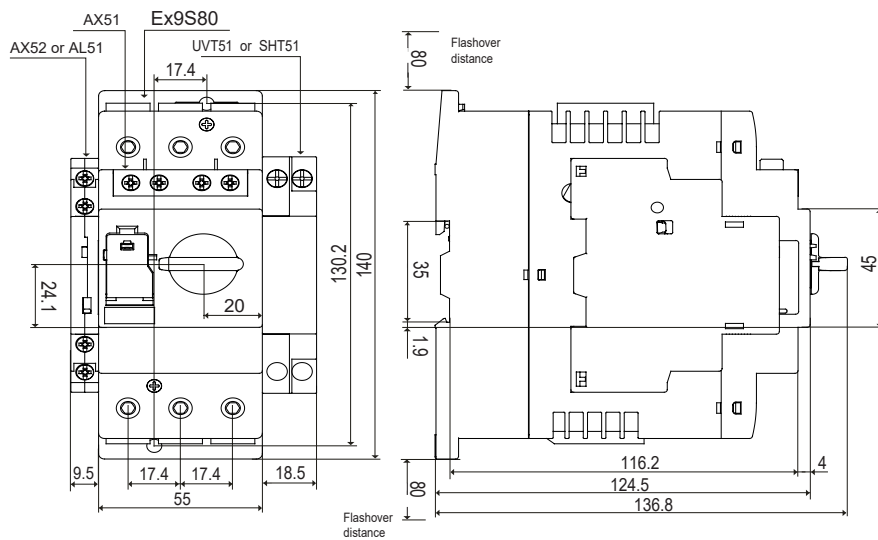



Manual Motor Starters

Ex9S ACCESSORIES: SPECIFICATIONS



Auxiliary Contact Blocks

Applies to Ex9S32 and Ex9S80

AX51	11
Description	Auxiliary Contact
AX51: Auxiliary contact (front mount only)	11: 1NO+1NC (AX51,AX52,AL51, AX53)
AX52: Auxiliary contact (left side only)	20: 2NO (AX51,AX52)
AX53: Auxiliary contact (front mount only)	02: 2NC (AX52)
AL51: Fault Signaling Contact (left side only)	

Description	Mounting Location	Max. No. of Blocks	Contact Type	Catalog number
Instantaneous auxiliary contacts	Front	1	NO+NC	AX5111
			NO+NO	AX5120
			NO+NC	AX5311
Fault Signaling Contact	Left Side	2	NO+NC	AX5211
			NO+NO	AX5220
			NC+NC	AX5202
		1	NO+NC	AL5111

Electrical Trip Unit

Applies to Ex9S32 and Ex9S80



UVT51	G	SHT51	G
Description	Rated Voltage	Description	Rated Voltage
UVT51: Undervoltage release (right side only)	A: 110~120V 60Hz(UVT51) B: 110~120V 50Hz & 127V 60Hz(UVT51) C: 208V 60Hz(UVT51) D: 240V 60Hz(UVT51) E: 480V 60Hz(UVT51) F: 600V 60Hz(UVT51) G: 220~240V 50Hz(UVT51) H: 380~415V 50Hz(UVT51)	SHT51: Shunt release (right side only)	A: 100~130V 50/60Hz(SHT51) B: 190~330V 50/60Hz(SHT51) C: 330~440V 50/60Hz(SHT51) D: 480~500V 50/60Hz(SHT51) E: 575~600V 50/60Hz(SHT51)

Description	Mounting Location	Voltage	Hz	Catalog number
Undervoltage Release	Right Side	110-120V	60	UVT51A
		127V	60	UVT51B
		110-120V	50	UVT51B
		208V	60	UVT51C
		240V	60	UVT51D
		480V	60	UVT51E
		600V	60	UVT51F
		220-240V	50	UVT51G
		380-415V	50	UVT51H
Shunt Release	Right Side	100-130V	50/60	SHT51A
		190-330V	50/60	SHT51B
		330-440V	50/60	SHT51C
		480-500V	50/60	SHT51D
		575-600V	50/60	SHT51E



Manual Motor Starters

Ex9S ACCESSORIES: SPECIFICATIONS

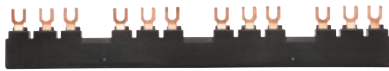

BBUM 454

Busbars

Applies to Ex9S32

Description	No. of Ex9S32 Starter	No. of Side-Mounted Aux Contact on each Ex9S32 starter	Busbar Pitch (mm)	Catalog number
Sets of 3-pole, 63A Busbar	2	None	45	BBUM 245
		1 of AX52, AL51	54	BBUM 254
		2 of AX52 or 1 UVT51, SHT51	63	BBUM 263
	3	None	45	BBUM 345
		1 of AX52, AL51	54	BBUM 354
		2 of AX52 or 1 UVT51, SHT51	63	BBUM 363
	4	None	45	BBUM 445
		1 of AX52, AL51	54	BBUM 454
		2 of AX52 or 1 UVT51, SHT51	63	BBUM 463
	5	None	45	BBUM 545
		1 of AX52, AL51	54	BBUM 554
		2 of AX52 or 1 UVT51, SHT51	63	BBUM 563



CCE51

Wiring Accessories

Applies to Ex9S32

Description	Application	Catalog number
Terminal Cover	Terminal cover for Ex9S32 for use in type E application	CCE51
Input Terminal for CBB51 Busbar	Terminal block for power supply to one or more CBB51 bus bar	FD51
Protective end cover	For unused busbar outlets	PC51



WPB51B



WPB51Y

Enclosures

Applies to Ex9S32

WPB	51	B
Description	Type	Color of Handle
Waterproof Enclosure	51: for Ex9S32	B: Black/Gray Y: Yellow/Red

Description	Type	Color	Rating	Catalog number
Waterproof Enclosure; Ex9S32 Protectors	Operation by rotary handle	Black/ Gray	NEMA 4X/4, IP 65	WPB51B
		Yellow/ Red		WPB51Y



Manual Motor Starters

Ex9S ACCESSORIES: SPECIFICATIONS



ERH51B

Operation Handle

Applies to Ex9S32 and Ex9S80

ERH	51	B
Description	Type	Color of Handle
Extended Rotary Handle	51: for Ex9S	B: Black/Gray Y: Yellow/Red

Description	Type	Color	Rating	Catalog number
Extended Rotary Handle	9 inch (230mm) shaft, with bracket	Black/ Gray Yellow/ Red	NEMA 4X/4, IP65	ERH51B ERH51Y

The extended rotary handle makes it possible for a door-mounted rotary handle to operate starter installed on the inside back panel of an enclosure. The extended rotary handle consists of the following:

- a set of screws onto the handle of the starter
- an assembly (handle and front plate) that fits on the enclosure door
- an extension shaft which must be adjusted according to the distance between the mounting surface and the door: 9 inch (230 mm)
- a bracket that install with starter and the shaft through



DRA51

Mounting Accessories

Applies to Ex9S32

DRA	51
Description	Type
Mounting Bracket	51: for mounting Ex9S32 with Ex9C 09-38A

CC	51
Description	Type
Combination Block	51: between Ex9S32 and Ex9CS 09-12A

Description	Application	Catalog number
Combination Block	Between Ex9S32 and Ex9C Mini Type Contactor, 09-12A	CC51
	Between Ex9S32 and Ex9C Standard Type Contactor, 09-18A	CC52
	Between Ex9S32 and Ex9C Standard Type Contactor, 25-38A	CC53
Mounting Bracket	For mounting a Ex9S32 to a Ex9C Standard Type Contactor, 09-38A	DRA51



Ex9S32 + CC53 + Ex9C32 + DRA51

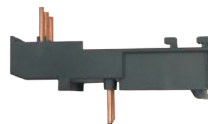

CC51



CC52

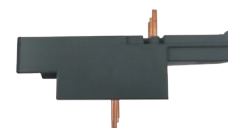

CC53



Manual Motor Starters

Ex9S ACCESSORIES: SPECIFICATIONS

Technical Data

	Auxiliary contacts AX51	Auxiliary contacts AX52	Auxiliary contacts AX53	Auxiliary contacts AX51
Rated operational voltage Ue	300V	600V	60VAC、24VDC	600V
Rated frequency	50/60Hz	50/60Hz	-	50/60Hz
Rated impulse withstand voltage Uimp	2500V	6000V	800V	6000V
Conventional rated thermal current (Ith) "	2.5A	5A	1A	5A
Mechanical life (C-O operations)	100000	100000	100000	100000
Electrical Rating	C300,Q300	B600,Q300	AC-12:60V/0.1A DC-12:24V/1A	B600,Q300
Minimum connection Load	5mA @24Vac/dc	8mA @24Vac/dc	2mA @12Vac/dc 3mA @5Vdc	8mA @24Vac/dc

Terminal Wiring

	Ex9S32	Ex9S80
Screw Type	M4, Phil-Slot head	M8, Phil-Hex head
Pull wire length inch (mm)	0.4 (10)	0.59 (15)
Wire range AWG	(1)x14-(2)x8	14~3
Torques lb-in (N.m)	22 (2.5)	53 (6)

	Model	Wire Ranges(AWG)	Torques lb-in (N.m)	Screw Type
Phil-Slot Head	AX51	(1)x18-(2)x12	7 (0.8)	M3
	AX52	(1)x18-(2)x12	7 (0.8)	M3
	AX53	(1)x18-(2)x14	7 (0.8)	M3
	AL51	(1)x18-(2)x12	7 (0.8)	M3
	UVT51	(1)x18-(2)x12	15 (1.7)	M3.5
	SHT51	(1)x18-(2)x12	15 (1.7)	M3.5

Electrical Diagram

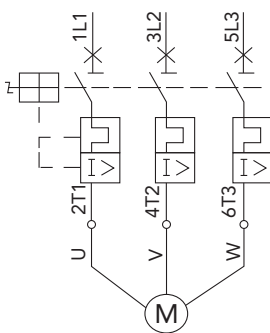

Operating principle diagram of starter

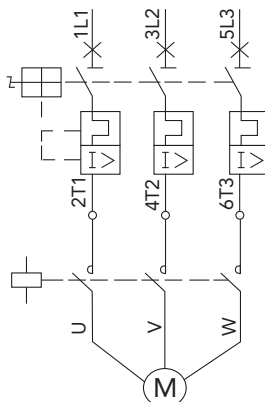

Principle connection diagram of starter and contactor

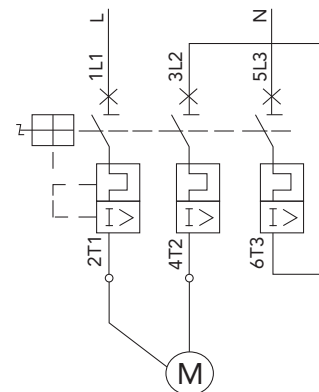

Principle connection diagram of single-phase Motor



Manual Motor Starters

Ex9S ACCESSORY DIMENSIONS

Ex9S32 + CC51 + Ex9CS06, 09, 12

Unit: in [mm]

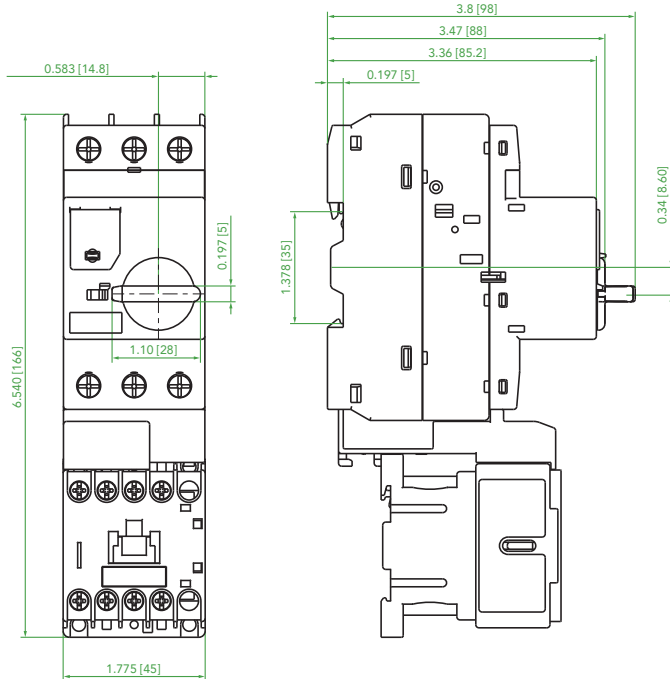

CC51

Unit: in [mm]

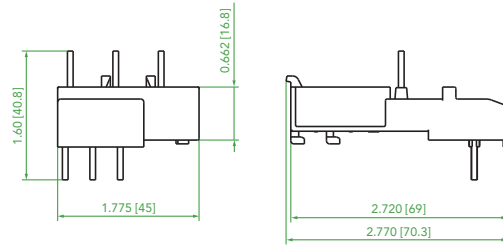

Ex9S32 + CC52 + Ex9C09, 12 18

Unit: in [mm]

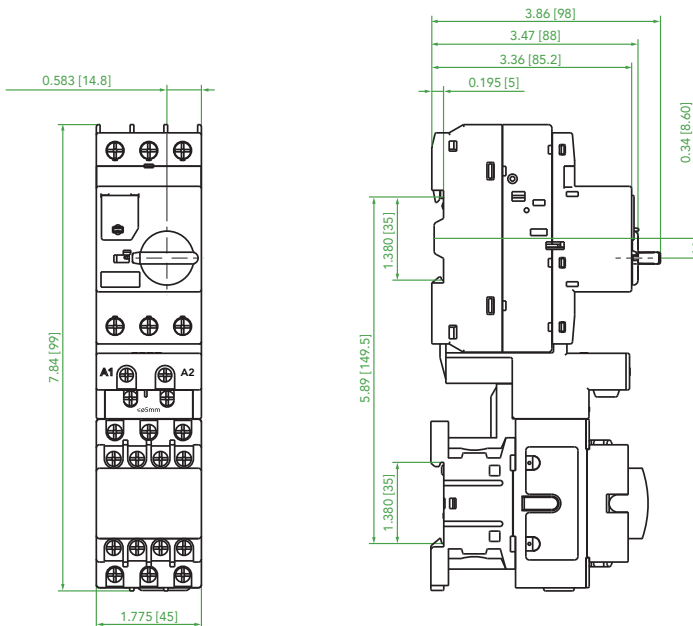

CC52

Unit: in [mm]

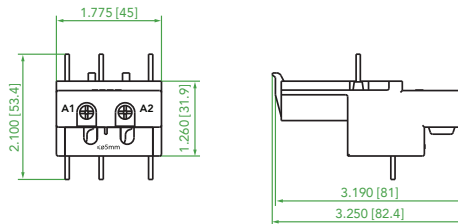



Manual Motor Starters

Ex9S ACCESSORY DIMENSIONS

Ex9S32 + CC52 + Ex9C09, 12, 18 + DRA51

Unit: in [mm]

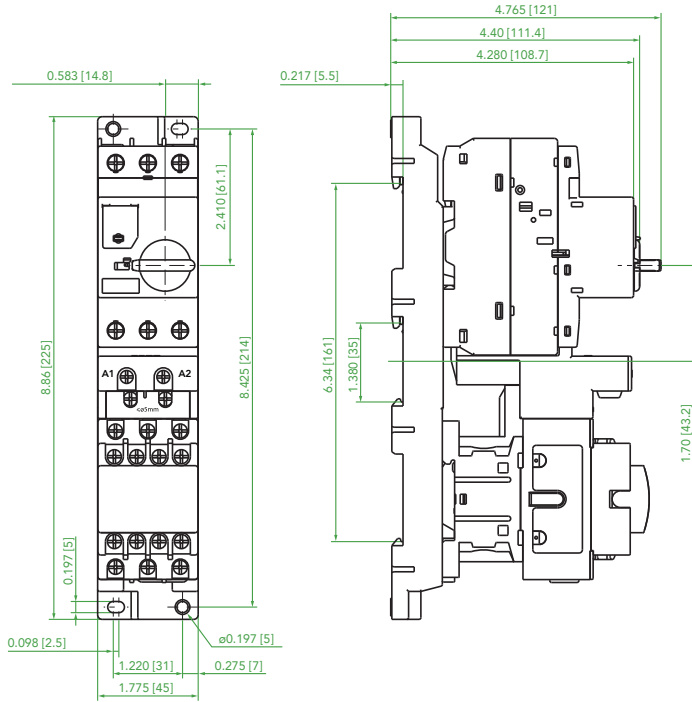

CC52

Unit: in [mm]

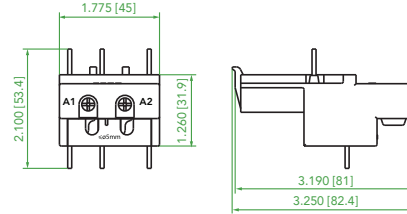

DRA51

Unit: in [mm]

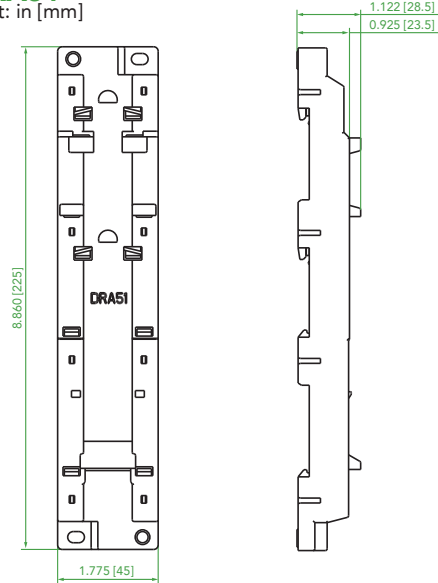

Ex9S32 + CC53 + Ex9C25, 32, 38

Unit: in [mm]

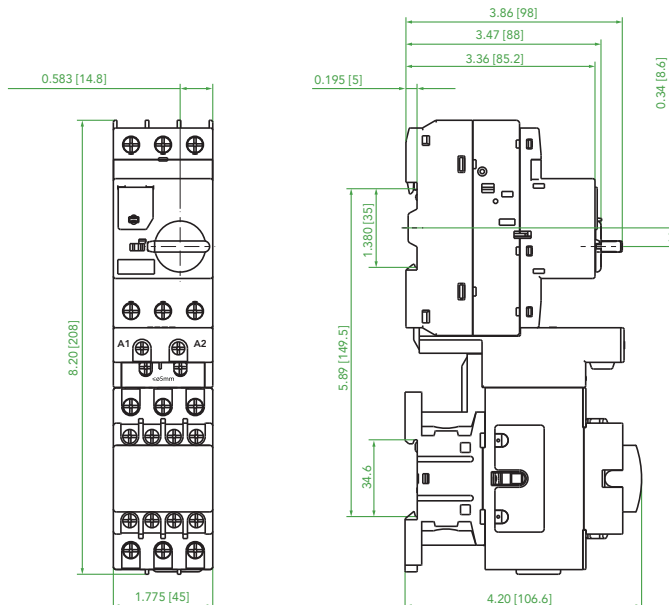

CC53

Unit: in [mm]

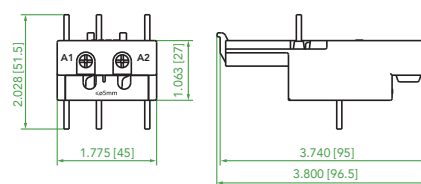



Manual Motor Starters

Ex9S ACCESSORY DIMENSIONS

Ex9S32 + CC53 + Ex9C25, 32, 38 + DRA51

Unit: in [mm]

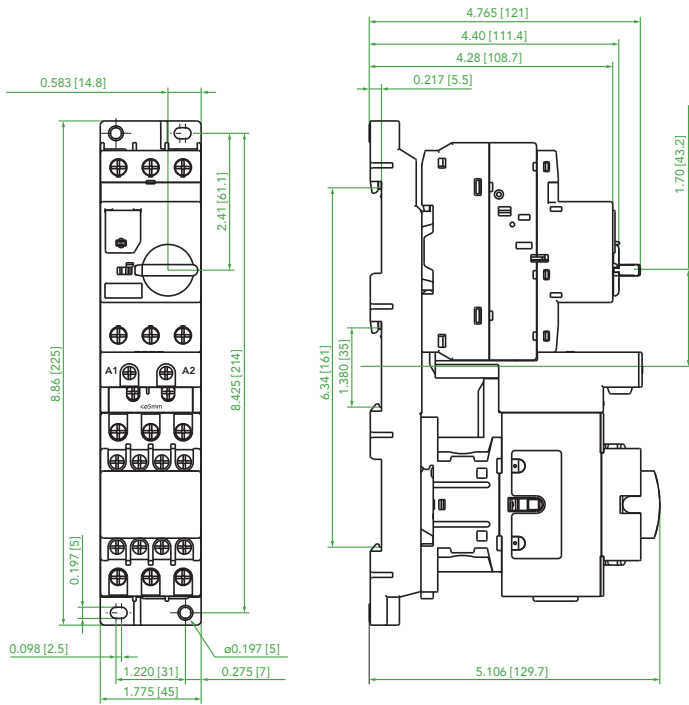

CC53

Unit: in [mm]

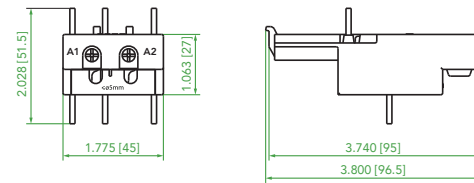

DRA51

Unit: in [mm]

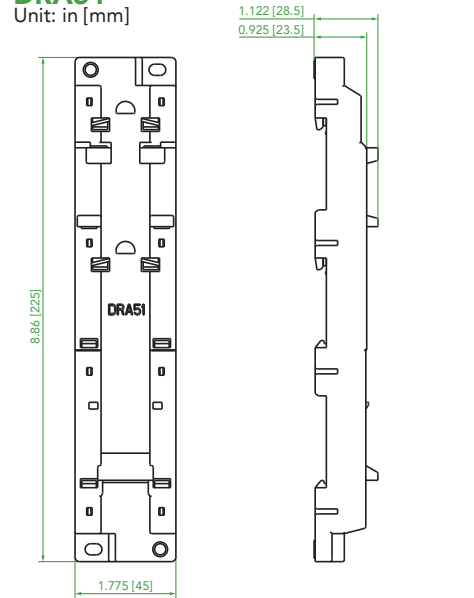

ERH51

Unit: in [mm]

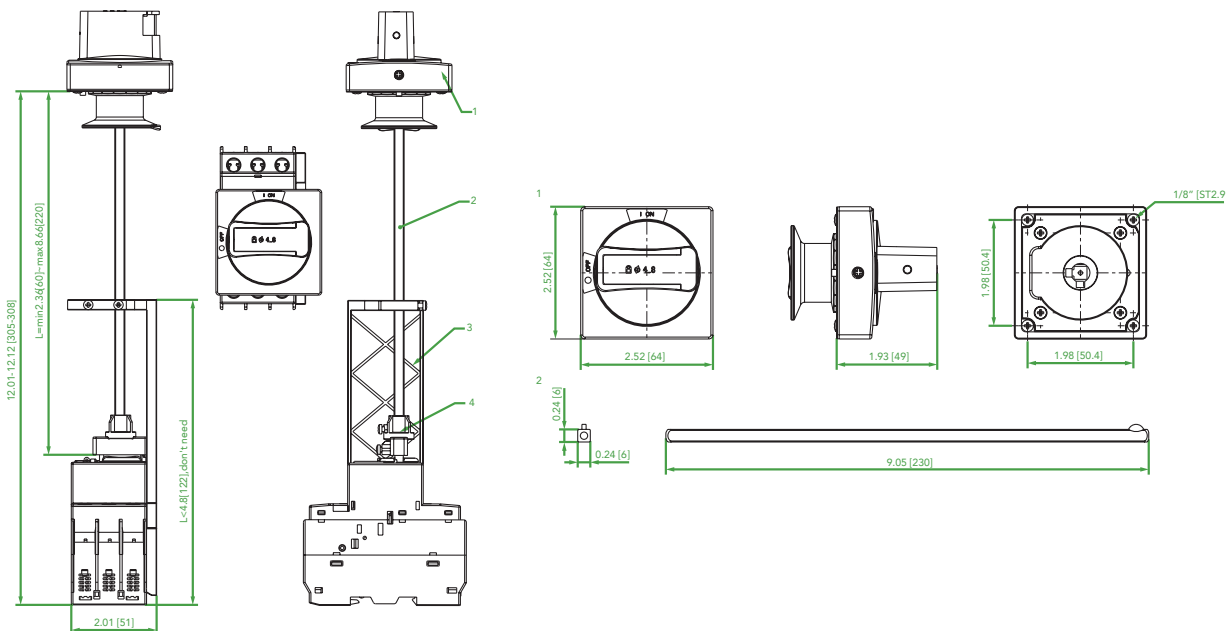



Manual Motor Starters

Ex9S ACCESSORY DIMENSIONS

WPB51

Unit: in [mm]

