

# Valkyrie Easy Install Airbox Mod Instructions

## The origin story.

In 2019, my son and I got tired of wrestling with the Valkyrie air box. Hours of time spent with inspection mirrors, 90-degree picks, lubrication, and spinning tubes to get the tubes onto the carb air funnels without folding them and getting vacuum leaks.

We rebuild lots of carbs and mount them on a test engine for balancing and tuning. We wanted a quick and easy way to install the airbox, so we invented one.

We went through prototypes and improvements to create something that works perfectly. We have been testing them on 7 bikes and our test engine since 2019.

Outside manufacturing is too costly, so we make them ourselves using 3D printing, to make them affordable.

- Tubes and nuts are 3D printed from ABS plastic like the airbox.
- Airbox is easy to Install correctly.
- No mirrors, picks, ty wraps, lubrication, twisting, or other methods needed.
- Doesn't change the air flow, so no re-tuning required.
- Seals tightly on tubes, no glue to come loose and leak.
- Complete kit with parts and detailed instructions.

This is a mod for the Honda Valkyrie 1500 air cleaner housing to make it easier to remove and install. Once the mod is completed the air cleaner can be easily installed. This modification makes no changes to the air flow.

The mod has the advantage of the air intake tubes being correctly and securely attached to the carbs before putting the airbox on. You will be able to install the air cleaner without inspection mirrors or folding the tubes. You won't need ty wraps, or lubrication, or twisting of the tubes. The resulting installation will be easy, leak free and will take a fraction of the time it takes to do it the old way.

## The Legal Statement:

We assume no liability for any damage, direct or otherwise, resulting from the use of these parts or this information. We created this mod for ease of maintenance on our own Valkyries, and though we have done a lot of road testing; if you choose to use these parts and information, you are doing so at your own risk.

Please read through and understand the entire procedure before making any changes to your bike.

# Valkyrie Easy Install Airbox Mod Instructions

## The Valkyrie Easy Install Airbox Mod Kit Description

The kit consists of 6 ABS Plastic tubes which are connected to the rubber air cleaner connecting tubes. The threaded end extends through the air cleaner housing (which I will hereafter refer to as the airbox). There are nuts and washers on the tubes inside the airbox. The nuts and washers secure the airbox leak free.

The airbox can easily be removed leaving the connecting tubes connected to the carbs. The airbox can be reinstalled by setting it over the 6 tubes, putting the nuts and washers on, and connecting the venturi tubes inside the airbox.

Below are the modified parts, and how they install in the airbox.



## The Valkyrie Easy Install Airbox Mod Kit Parts

- 6 - 3D printed tubes
- 6 - 3D printed Nuts
- 6 - conical rubber washers
- 6 - flat plastic washers
- 6 - hose clamps
- 1 - Disposable Knife



# Valkyrie Easy Install Airbox Mod Instructions

## Tooling

Hand tools for removing and installing the fuel tank and Airbox.

## Instructions

Refer to the Service Manual for detailed instructions for removal of the seat, tank and air cleaner as needed. I figure most people wanting to install this mod have already suffered through the removal and installation of the airbox and know the steps, but here is a checklist. See the drawing to identify parts for #'s referenced.

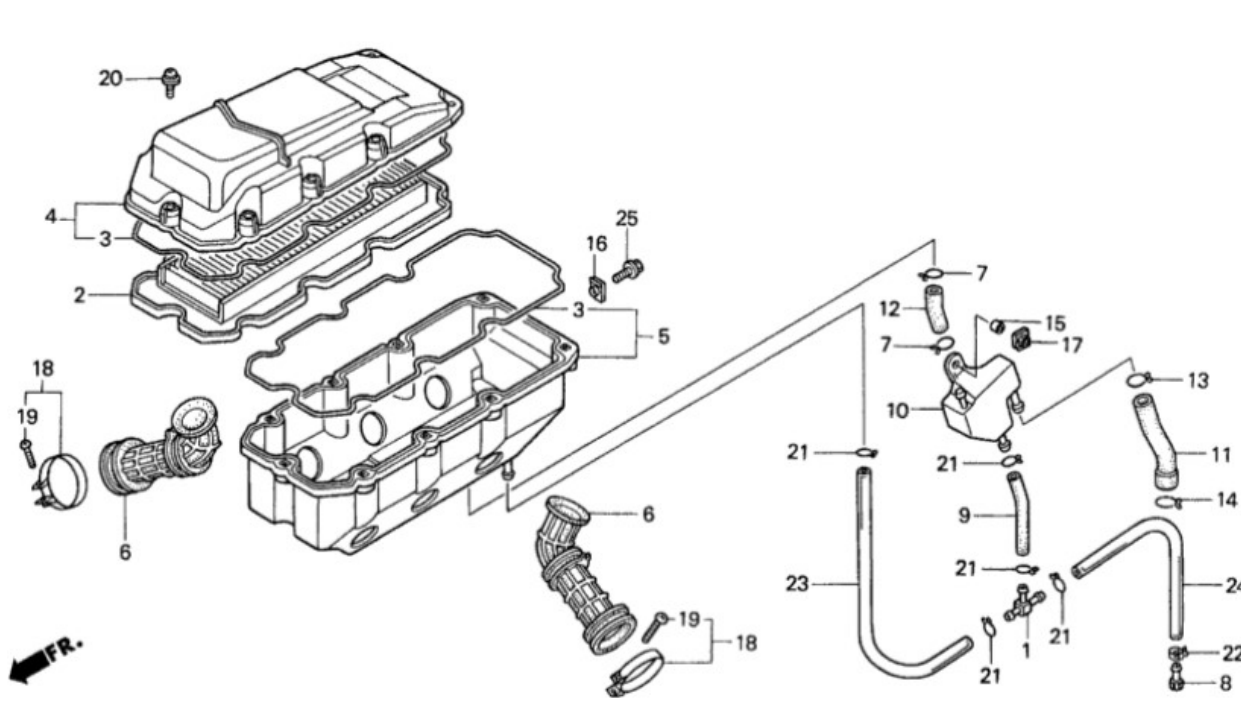

## **Remove the Airbox**

**The following steps were derived from the Honda Service Manual.**

1. Remove seat.
2. Remove tank.
3. Remove air cleaner housing cover #4.
4. Remove air cleaner (filter) #2.
5. On the left side remove 2 bolts and number 1–2-cylinder ignition coil.
6. Loosen air cleaner connecting tube bands #18 at all 6 carburetors.
7. On the right side remove crankcase breather storage tank hose #12 from the air cleaner housing.
8. Remove flange bolt #25 securing airbox to frame.
9. On the left side remove drain tube #23 from the air cleaner housing.
10. On the left side remove the secondary air supply hose from the air cleaner housing. (Not shown in parts diagram but is just in front of the drain tube. If your bike is de-smogged the tube will be gone, and the port will be plugged.)

# Valkyrie Easy Install Airbox Mod Instructions

11. Remove the air cleaner housing with connecting tubes attached.



Throughout the procedure I will note some “Critical Steps.” These are steps that affect the length of the threads extending into the airbox. The procedure is designed to result in the exact number of threads for proper thread engagement on the nut and a seal against the airbox. Whereas it is important to perform all steps correctly, the “Critical” Steps are critical for proper installation, and operation.

**SAFETY NOTE:** The knife in the kit is sharp with an exposed blade. It is among the most dangerous tools on the planet. It happens to be what we need to do the job.

**USE CAUTION.** Stay out of the “line of fire” of the tool. Meaning do not be in the path of the blade if you should slip. When cutting use only the force needed to make the cut. Maintain control of the tool. Retract the blade when not using it to cut. Respect the tool. It does not care what it cuts.

**STOP- IF you did not read the above safety note read it now.**

11. On the outside of the airbox, cut one air cleaner connecting tube (#6, rubber tube), between the airbox and the flange of the tube. (No need to remove the rubber tube from the airbox. Just cut along the airbox.)



Use the disposable knife from the kit. Extend the blade as shown and lock it. Keep the knife flat against the airbox and cut a little and turn the tube to cut more. It will cut easily.



# Valkyrie Easy Install Airbox Mod Instructions



You will now have the internal venturi tube free as well. They have a ridge where it extended through the airbox.

We will trim these edges in steps below.

**The following step is a Critical Step.**

12. Trim the cut edge of the venturi so that it is flat. **Do Not bevel it.** Save the venturi tube for later.

**The following step is a Critical Step.**

13. Trim excess rubber from the end of the rubber tube that was against the airbox so it will sit flat.

**On the end of the rubber tube from where you just cut off the flange, we will shorten it by the thickness of the rubber conical washer.**

14. First cut off the little tab that kept it from turning in the airbox, so it doesn't alter your measurement.



# Valkyrie Easy Install Airbox Mod Instructions

15. Stand the tube up with the conical washer next to it as shown.



Conical washer wide side UP.

Marking the tube and cutting it to the correct length are critical steps.

16. Mark the rubber tube at each rib where the conical washer contacts the rib.

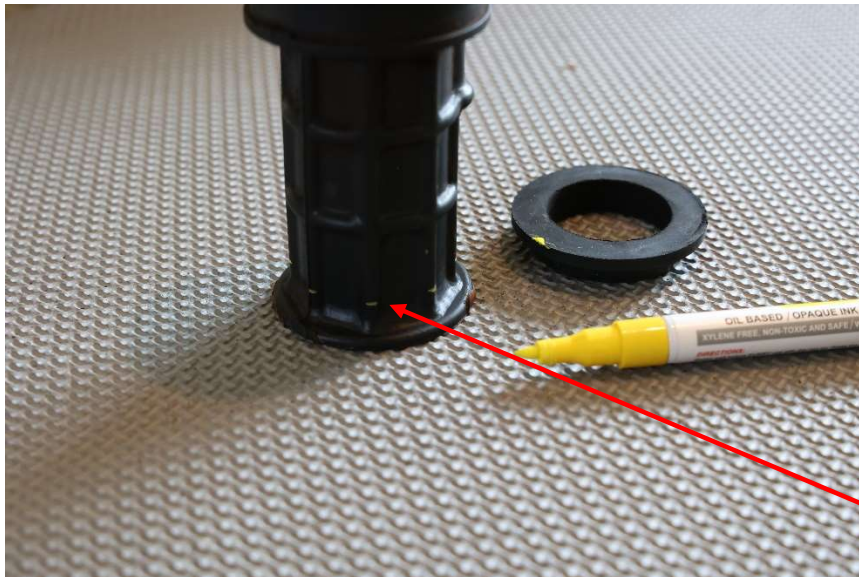

I used an oil paint marker for visibility, but a ball point pen will work, It is just harder to see. Marks need to be fine for accurate cuts later.

My yellow marks.

**SAFETY NOTE: Cut only when pulling the knife.**

**When pushing the knife use light pressure just to reposition it. Cutting while pulling gives better control.**

# Valkyrie Easy Install Airbox Mod Instructions

17. Cut the rubber tube a little at each mark. See below picture.



18. Continue to cut the tube evenly, going from mark to mark until the end is separated from the tube.  
19. Discard the cut off end.



Shortened  
Rubber tube

Cut off end of  
tube. Throw away.

Conical washer

Venturi tube

# Valkyrie Easy Install Airbox Mod Instructions

**NOTE:** If you have difficulty assembling the parts lubricating with alcohol helps. Do not use any other lubricants.

**The following step is a Critical Step.**

20. Insert the smooth end of the kit tube into the rubber tube. The top of the rubber tube should be at the edge of the raised smooth shoulder of the insert.

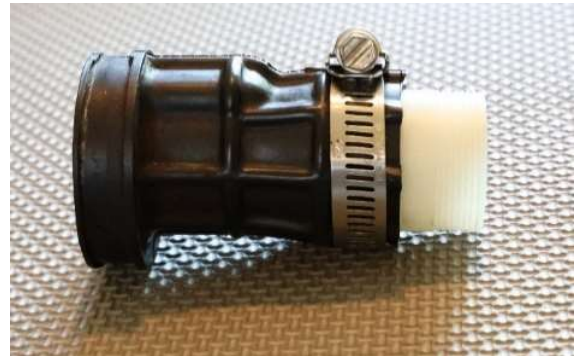
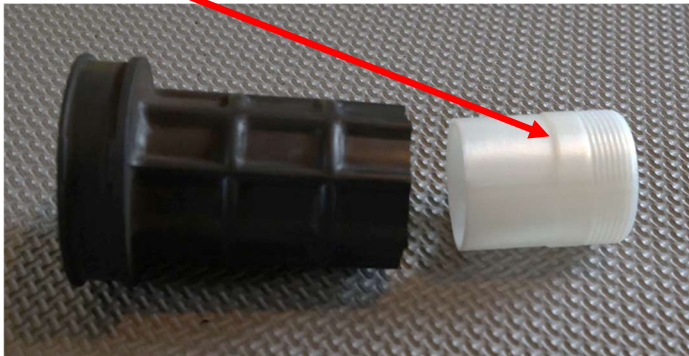

21. Apply a hose clamp on the rubber tube as shown to secure the insert. Align the clamp screw with the bulge in the rubber tube.

22. Place the rubber conical washer with the small end toward the rubber tube.

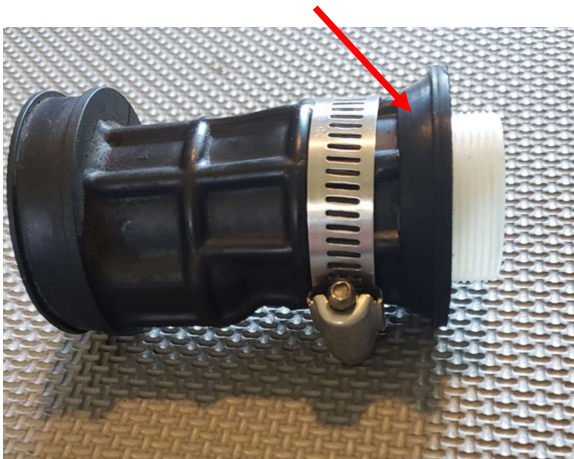

Completed airbox mod tube.



Completed airbox mod tube with washer, nut, and venturi.

23. Repeat steps 11 through 22 for the other 5 tubes.



# Valkyrie Easy Install Airbox Mod Instructions

## Connecting the tubes to the carbs

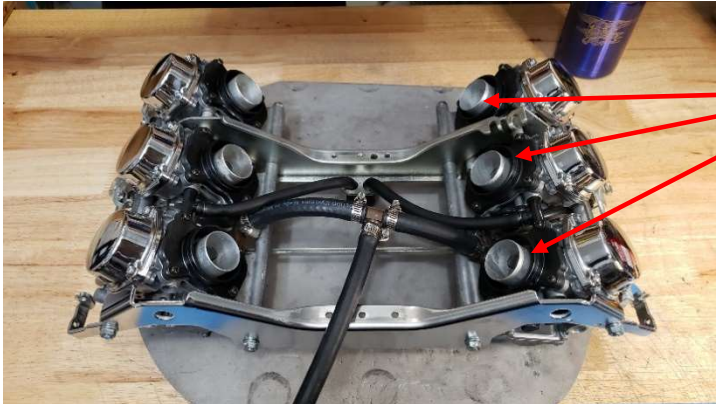

Air Horns of the carbs

**These should fit easily with clamps loose. Lubricate with alcohol if needed. Do not use any other lubricants.**

24. Connect a completed tube assembly on the air horn of a carb. **Verify the bulge faces down**, and the assembly is fully seated.
25. Tighten clamp #18 to secure it to the carb.
26. Repeat steps 24 and 25 for each carb and tube assembly.

## In the following steps we are going to install the air box.

**NOTE:** The Airbox won't drop right onto the tubes, but it will be close. Tilt it to one side and use your finger to guide the tubes into the holes. With three tubes on one side installed, the three on the other side go in easily.

27. Install the lower half of the airbox as you adjust the 6 tubes through the holes in the bottom.

## The following step is a Critical Step.

28. Place a flat washer on each tube.



**NOTE:** The washers are tight, and you will need to work them down over the threads. Pressing the airbox down to provide more threads helps.

This washer provides a slick surface for the nut to slide on. The thickness of the washer is calculated in the measurements and cutting.

# Valkyrie Easy Install Airbox Mod Instructions

29. Start a nut on each tube.



**NOTE:** The top of the nut provides the mounting for the venturi tube, so there is a shoulder inside the nut. If all the parts are cut and assembled correctly, the tube threads will just barely reach the shoulder. Overtightening will jamb the threads against the shoulder of the nut. Excessive overtightening may strip the threads.

30. Make several passes to tighten all 6 nuts finger tight and pull the airbox down against the rubber conical washer to seal the airbox tubes.

31. Place the venturi tubes on the nuts. The left-side tubes face rear. The right-side tubes face front. Alcohol on the rubber helps with installation.

**Lubricate with alcohol if needed.**

**Do not use any other lubricants.**



32. On the left side install the secondary air supply hose if it was removed in step 10. (If your bike is de-smogged the nipple on the airbox will be plugged, and the hose removed.)

33. On the left side install the drain tube #23.

34. Install flange bolt #25 securing the airbox to the frame.

35. On the right side install the crankcase breather storage tank hose #12.

36. On the left side install 2 bolts and the number 1–2-cylinder ignition coil.

37. Install air cleaner (filter) #2.

38. Install air cleaner housing cover #4, and gasket if removed.

39. Install tank.

40. Install seat.

41. Enjoy the ride.

END OF PROCEDURE