

New HSU Series - Cased Hot Water Coils

- Built to ARI 410 Certification
- Galvanized Embossed, 18 Ga. frame
- Aluminum Fins, .005 Thickness
- Copper Tubing, 3/8" w/ .012 wall
- **8" Height**
- 7/8 OD Connections
- **BTU outputs from 20,000 to 120,000**
- Horizontal/Vertical Installation
- **Two year warranty**
- Call for other performance criteria ratings

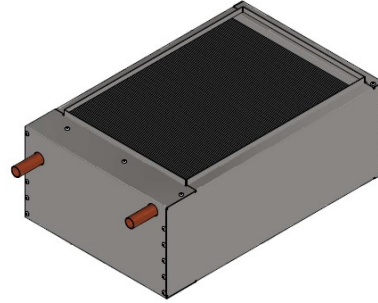

Dimensional Data

H2O COIL	A	B	C	D	E	F	
HSU-2-1425	14-1/4"	13 1/4	8"	22"	18"	1"	3"
HSU-2-1750	17-1/2"	16-1/2	8"	22"	18"	1"	3"
HSU-2-1850	18-1/2"	17-1/2	8"	21"	17	1"	3"
HSU-2-1975	19-3/4"	18-3/4	8"	22"	18	1"	3"
HSU-2-2125	21-1/4"	20-1/4"	8"	22"	18"	1"	3"
HSU-2-2225	22-1/4"	21-1/4	8"	22"	18	1"	3"
HSU-2-2350	23-1/2"	22 1/2"	8"	21"	17	1"	3"
HSU-2-2450	24-1/2"	23-1/2"	8"	22"	18"	1"	3"
HSU-2-2650	26-1/2"	25-1/2	8"	21"	17	1"	3"

H2O COIL	CFM	APD"	BTU@180EWT	WPD'
HSU-2-1425	800	.14	50,230	4.6
HSU-2-1750	1200	.19	65,917	2.7
HSU-2-1850	1200	.19	66,511	3.4
HSU-2-1975	1400	.21	75,037	3.5
HSU-2-2125	1600	.22	82,470	3.2
HSU-2-2250	1800	.24	88,513	3.3
HSU-2-2350	1600	.21	84,588	4.2
HSU-2-2450	2000	.25	96,239	3.6
HSU-2-2650	2000	.24	97,259	3.8

In STOCK
Feb 2022

All Coils Ratings based on 55 degree EAT, 7 GPM
EWT Correction Factors: .835 @ 160, .670 @140, .507 @ 120

D-VAC Sales Inc.

www.dvachvac.com TEL: (516) 256-3131 e-mail: sales@dvachvac.com