



POWER YOUR FUTURE

Evopower Generators

- Cummins diesel engines
- UK Specification
- Deepsea control panels
- Varta batteries
- CHiNT Breakers
- Rust proofed weather proof canopies
- Heavy duty base skids with forklift & lifting eyes
- 2 years Engine warranty*
- 3 years Genpower alternator warranty*
- 3 years interest free credit available*



Evopower Series – Powered By Cummins

Technical Data: Model UKC125ECO-LR

Evopower Generator

Prime Power	113kVA
Standby Power	125kVA
Voltage Line To Line	400V
Current Per Phase (Prime)	163A
Current Per Phase (Standby)	180A
Sound Level	70dB @7m

Engine – DCEC Cummins

Model	6BT5.9-G2
Aspiration	Turbo
Fuel System	ADType
No. Cylinders	6
Displacement	5.9L
Bore*Stroke	102*120mm
Compression Ratio	17.5
Rated Speed	1500r/min
Net Power - prime	96kW
Governor Type	Electrical
Starter Motor	24V

Exhaust System

Exhaust Gas Flow	116.8m ³ /min
Exhaust Gas Temp.	565°C
Max. Back Pressure	10kPa

Aspiration System

Max. Inlet Pressure	6.35kPa
Combustion Volume	6.48m ³ /min
Air Flow	158m ³ /min

Fuel System

100% Load (Prime Power)	22L/h
75% Load (Prime Power)	17L/h
50% Load (Prime Power)	11L/h
Fuel Tank Capacity	580L

Lubrication System

Oil Capacity	16.4L
Oil Pressure (Continuous Operation)	345kPa

Cooling System

Coolant Capacity	29L
Thermostat Operation Range	82-95°C
Max. Water Temperature	104°C

Alternator

Model	Genpower	LK274D
	Optional: Stamford	UC1274D
Phase		3
Voltage		400/230V
Wiring Type		3 Phase 4 Wire, Y Type
Bearing		1
Power Factor		0.8
Frequency		50Hz
Prime Power		138kVA
Exciter Type		Brushless, Self-Excitation
Voltage Regulation		±0.5%
Protection Grade		IP 23
Insulation Grade		H/H
Altitude		≤1000m

Controller - DEEPSEA

Model	DSE6120
-------	---------

Protective Functions:

- Low Oil Pressure
- High Water Temperature
- High/Low Voltage
- High Engine Temperature And Overspeed
- Voltage Regulator Frequency Regulator
- Emergency Stop
- Start Failure



Control Module Options



- Auto Generator Control Module
- Control Module With “Remote Control” Functions
- ATS Auto Load Transfer Screen
- Synchronising Control Modules
- Power Output Cabinet

Technical Data: Model UKC125ECO-LR

Standard Features

- Engine (DCEC Cummins)
- Radiator 50°C Max, engine driven fan
- 24V charge alternator
- Main Alternator: Single bearing alternator IP23, insulation class H/H
- Deep Sea standard auto control system
- 1 set of air filter, fuel filters & oil filters included
- Main line circuit breaker/MCCB by CHNT
- Base mounted fuel tank
- Twin Varta batteries
- Low noise exhaust system with rain flap
- User manual

Options

- Battery charger
- Engine coolant heater
- Alternator heater
- Water oil separator
- 24/48h long run bunded fuel tank
- 3-way fuel valves for remote fuel tank
- Remote control panel
- Automatic transfer switch/ATS
- Paralleling multiple sets

Warranty*

Cummins Engine

12 months for prime power use (1200h per year)*

24 months for standby use (500h per year)*

* Full engine service intervals to be adhered to.

Genpower Alternator

36 Months from date of purchase or 3000 hours

Generator general components

12 months

Unit Dimensions (Basic Unit)

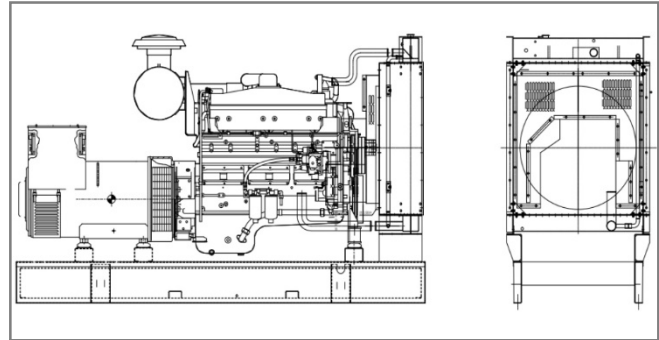

Open Type

L x W x H

2200 x 880 x 1360mm

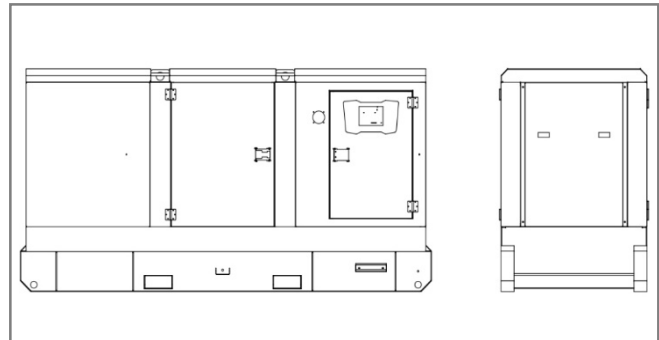

Silent Type

L x W x H

2938 x 1080 x 1830mm

Weight

1833kg

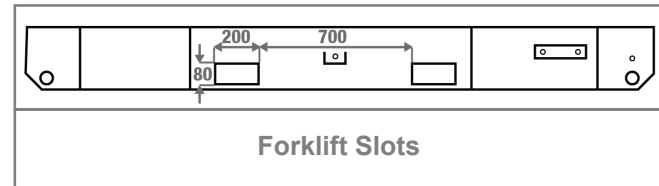

Forklift Slots

*Interest free finance available subject to status

